



PIC24FJ256DA210 Family Data Sheet

64/100-Pin,
16-Bit Flash Microcontrollers
with Graphics Controller and
USB On-The-Go (OTG)

Note the following details of the code protection feature on Microchip devices:

- Microchip products meet the specification contained in their particular Microchip Data Sheet.
- Microchip believes that its family of products is one of the most secure families of its kind on the market today, when used in the intended manner and under normal conditions.
- There are dishonest and possibly illegal methods used to breach the code protection feature. All of these methods, to our knowledge, require using the Microchip products in a manner outside the operating specifications contained in Microchip's Data Sheets. Most likely, the person doing so is engaged in theft of intellectual property.
- Microchip is willing to work with the customer who is concerned about the integrity of their code.
- Neither Microchip nor any other semiconductor manufacturer can guarantee the security of their code. Code protection does not mean that we are guaranteeing the product as "unbreakable."

Code protection is constantly evolving. We at Microchip are committed to continuously improving the code protection features of our products. Attempts to break Microchip's code protection feature may be a violation of the Digital Millennium Copyright Act. If such acts allow unauthorized access to your software or other copyrighted work, you may have a right to sue for relief under that Act.

Information contained in this publication regarding device applications and the like is provided only for your convenience and may be superseded by updates. It is your responsibility to ensure that your application meets with your specifications. MICROCHIP MAKES NO REPRESENTATIONS OR WARRANTIES OF ANY KIND WHETHER EXPRESS OR IMPLIED, WRITTEN OR ORAL, STATUTORY OR OTHERWISE, RELATED TO THE INFORMATION, INCLUDING BUT NOT LIMITED TO ITS CONDITION, QUALITY, PERFORMANCE, MERCHANTABILITY OR FITNESS FOR PURPOSE. Microchip disclaims all liability arising from this information and its use. Use of Microchip devices in life support and/or safety applications is entirely at the buyer's risk, and the buyer agrees to defend, indemnify and hold harmless Microchip from any and all damages, claims, suits, or expenses resulting from such use. No licenses are conveyed, implicitly or otherwise, under any Microchip intellectual property rights.

Trademarks

The Microchip name and logo, the Microchip logo, dsPIC, KEELOQ, KEELOQ logo, MPLAB, PIC, PICmicro, PICSTART, PIC³² logo, rPIC and UNI/O are registered trademarks of Microchip Technology Incorporated in the U.S.A. and other countries.

FilterLab, Hampshire, HI-TECH C, Linear Active Thermistor, MXDEV, MXLAB, SEEVAL and The Embedded Control Solutions Company are registered trademarks of Microchip Technology Incorporated in the U.S.A.

Analog-for-the-Digital Age, Application Maestro, CodeGuard, dsPICDEM, dsPICDEM.net, dsPICworks, dsSPEAK, ECAN, ECONOMONITOR, FanSense, HI-TIDE, In-Circuit Serial Programming, ICSP, Mindi, MiWi, MPASM, MPLAB Certified logo, MPLIB, MPLINK, mTouch, Octopus, Omniscient Code Generation, PICC, PICC-18, PICDEM, PICDEM.net, PICKit, PICtail, REAL ICE, rLAB, Select Mode, Total Endurance, TSHARC, UniWinDriver, WiperLock and ZENA are trademarks of Microchip Technology Incorporated in the U.S.A. and other countries.

SQTP is a service mark of Microchip Technology Incorporated in the U.S.A.

All other trademarks mentioned herein are property of their respective companies.

© 2010, Microchip Technology Incorporated, Printed in the U.S.A., All Rights Reserved.

 Printed on recycled paper.

ISBN: 978-1-60932-235-9

Microchip received ISO/TS-16949:2002 certification for its worldwide headquarters, design and wafer fabrication facilities in Chandler and Tempe, Arizona; Gresham, Oregon and design centers in California and India. The Company's quality system processes and procedures are for its PIC® MCUs and dsPIC® DSCs, KEELOQ® code hopping devices, Serial EEPROMs, microperipherals, nonvolatile memory and analog products. In addition, Microchip's quality system for the design and manufacture of development systems is ISO 9001:2000 certified.

**QUALITY MANAGEMENT SYSTEM
CERTIFIED BY DNV
== ISO/TS 16949:2002 ==**



PIC24FJ256DA210 FAMILY

64/100-Pin, 16-Bit Flash Microcontrollers with Graphics Controller and USB On-The-Go (OTG)

Graphics Controller Features:

- Three Graphics Hardware Accelerators to Facilitate Rendering of Block Copying, Text and Unpacking of Compressed Data
- Color Look-up Table (CLUT) with Maximum of 256 Entries
- 1/2/4/8/16 bits-per-pixel (bpp) Color Depth Set at Run Time
- Display Resolution Programmable According to Frame Buffer:
 - Supports direct access to external memory on devices with EPMP
 - Resolution supported is up to 480x272 @ 60 Hz, 16 bpp; 640x480 @ 30 Hz, 16 bpp or 640x480 @ 60 Hz, 8 bpp
- Supports Various Display Interfaces:
 - 4/8/16-bit Monochrome STN
 - 4/8/16-bit Color STN
 - 9/12/18/24-bit Color TFT (18 and 24-bit displays are connected as 16-bit, 5-6-5 RGB color format)

Universal Serial Bus Features:

- USB v2.0 On-The-Go (OTG) Compliant
- Dual Role Capable – Can act as either Host or Peripheral
- Low-Speed (1.5 Mbps) and Full-Speed (12 Mbps) USB Operation in Host mode
- Full-Speed USB Operation in Device mode
- High-Precision PLL for USB
- Supports up to 32 Endpoints (16 bidirectional):
 - USB module can use the internal RAM location from 0x800 to 0xFFFF as USB endpoint buffers
- On-Chip USB Transceiver with Interface for Off-Chip Transceiver
- Supports Control, Interrupt, Isochronous and Bulk Transfers
- On-Chip Pull-up and Pull-Down Resistors

Peripheral Features:

- Enhanced Parallel Master Port/Parallel Slave Port (EPMP/PSP), 100-pin devices only:
 - Direct access from CPU with an Extended Data Space (EDS) interface
 - 4, 8 and 16-bit wide data bus
 - Up to 23 programmable address lines
 - Up to 2 chip select lines
 - Up to 2 Acknowledgement lines (one per chip select)
 - Programmable address/data multiplexing
 - Programmable address and data Wait states
 - Programmable polarity on control signals
- Peripheral Pin Select:
 - Up to 44 available pins (100-pin devices)
- Three 3-Wire/4-Wire SPI modules (supports 4 Frame modes)
- Three I²C™ modules Supporting Multi-Master/Slave modes and 7-Bit/10-Bit Addressing
- Four UART modules:
 - Supports RS-485, RS-232, LIN/J2602 protocols and IrDA®
- Five 16-Bit Timers/Counters with Programmable Prescaler
- Nine 16-Bit Capture Inputs, each with a Dedicated Time Base
- Nine 16-Bit Compare/PWM Outputs, each with a Dedicated Time Base
- Hardware Real-Time Clock and Calendar (RTCC)
- Enhanced Programmable Cyclic Redundancy Check (CRC) Generator
- Up to 5 External Interrupt Sources

| PIC24FJ Device | Pins | Program Memory (bytes) | SRAM (bytes) | Remappable Peripherals | | | | | I ² C™ | 10-Bit A/D (ch) | Comparators | CTMU | EPMP/PSP | RTCC | Graphics Controller | USB OTG |
|-----------------|---------|------------------------|--------------|------------------------|---------------|-----------|--------------|-----|-------------------|-----------------|-------------|------|----------|------|---------------------|---------|
| | | | | Remappable Pins | 16-Bit Timers | IC/OC PWM | UART w/IrDA® | SPI | | | | | | | | |
| PIC24FJ128DA106 | 64 | 128K | 24K | 29 | 5 | 9/9 | 4 | 3 | 3 | 16 | 3 | Y | N | Y | Y | Y |
| PIC24FJ256DA106 | 64 | 256K | 24K | 29 | 5 | 9/9 | 4 | 3 | 3 | 16 | 3 | Y | N | Y | Y | Y |
| PIC24FJ128DA110 | 100/121 | 128K | 24K | 44 | 5 | 9/9 | 4 | 3 | 3 | 24 | 3 | Y | Y | Y | Y | Y |
| PIC24FJ256DA110 | 100/121 | 256K | 24K | 44 | 5 | 9/9 | 4 | 3 | 3 | 24 | 3 | Y | Y | Y | Y | Y |
| PIC24FJ128DA206 | 64 | 128K | 96K | 29 | 5 | 9/9 | 4 | 3 | 3 | 16 | 3 | Y | N | Y | Y | Y |
| PIC24FJ256DA206 | 64 | 256K | 96K | 29 | 5 | 9/9 | 4 | 3 | 3 | 16 | 3 | Y | N | Y | Y | Y |
| PIC24FJ128DA210 | 100/121 | 128K | 96K | 44 | 5 | 9/9 | 4 | 3 | 3 | 24 | 3 | Y | Y | Y | Y | Y |
| PIC24FJ256DA210 | 100/121 | 256K | 96K | 44 | 5 | 9/9 | 4 | 3 | 3 | 24 | 3 | Y | Y | Y | Y | Y |

PIC24FJ256DA210 FAMILY

[查询PIC24FJ256DA106供应商](#)

High-Performance CPU

- Modified Harvard Architecture
- Up to 16 MIPS Operation at 32 MHz
- 8 MHz Internal Oscillator
- 17-Bit x 17-Bit Single-Cycle Hardware Multiplier
- 32-Bit by 16-Bit Hardware Divider
- 16 x 16-Bit Working Register Array
- C Compiler Optimized Instruction Set Architecture with Flexible Addressing modes
- Linear Program Memory Addressing, up to 12 Mbytes
- Data Memory Addressing, up to 16 Mbytes:
 - 2K SFR space
 - 30K linear data memory
 - 66K extended data memory
 - Remaining (from 16 Mbytes) memory (external) can be accessed using extended data Memory (EDS) and EPMP (EDS is divided into 32-Kbyte pages)
- Two Address Generation Units for Separate Read and Write Addressing of Data Memory

Power Management:

- On-Chip Voltage Regulator of 1.8V
- Switch between Clock Sources in Real Time
- Idle, Sleep and Doze modes with Fast Wake-up and Two-Speed Start-up
- Run Mode: 800 μ A/MIPS, 3.3V Typical
- Sleep mode Current Down to 20 μ A, 3.3V Typical
- Standby Current with 32 kHz Oscillator: 22 μ A, 3.3V Typical

Analog Features:

- 10-Bit, up to 24-Channel Analog-to-Digital (A/D) Converter at 500 kbps:
 - Operation is possible in Sleep mode
 - Band gap reference input feature
- Three Analog Comparators with Programmable Input/Output Configuration
- Charge Time Measurement Unit (CTMU):
 - Supports capacitive touch sensing for touch screens and capacitive switches
 - Minimum time measurement setting at 100 ps
- Available LVD Interrupt VLVD Level

Special Microcontroller Features:

- Operating Voltage Range of 2.2V to 3.6V
- 5.5V Tolerant Input (digital pins only)
- Configurable Open-Drain Outputs on Digital I/O Ports
- High-Current Sink/Source (18 mA/18 mA) on all I/O Ports
- Selectable Power Management modes:
 - Sleep, Idle and Doze modes with fast wake-up
- Fail-Safe Clock Monitor (FSCM) Operation:
 - Detects clock failure and switches to on-chip, FRC oscillator
- On-Chip LDO Regulator
- Power-on Reset (POR) and Oscillator Start-up Timer (OST)
- Brown-out Reset (BOR)
- Flexible Watchdog Timer (WDT) with On-Chip Low-Power RC Oscillator for Reliable Operation
- In-Circuit Serial Programming™ (ICSP™) and In-Circuit Debug (ICD) via 2 Pins
- JTAG Boundary Scan Support
- Flash Program Memory:
 - 10,000 erase/write cycle endurance (minimum)
 - 20-year data retention minimum
 - Selectable write protection boundary
 - Self-reprogrammable under software control
 - Write protection option for Configuration Words

PIC24FJ256DA210 FAMILY

[查询PIC24FJ256DA106供应商](#)

Pin Diagram (64-Pin TQFP/QFN)

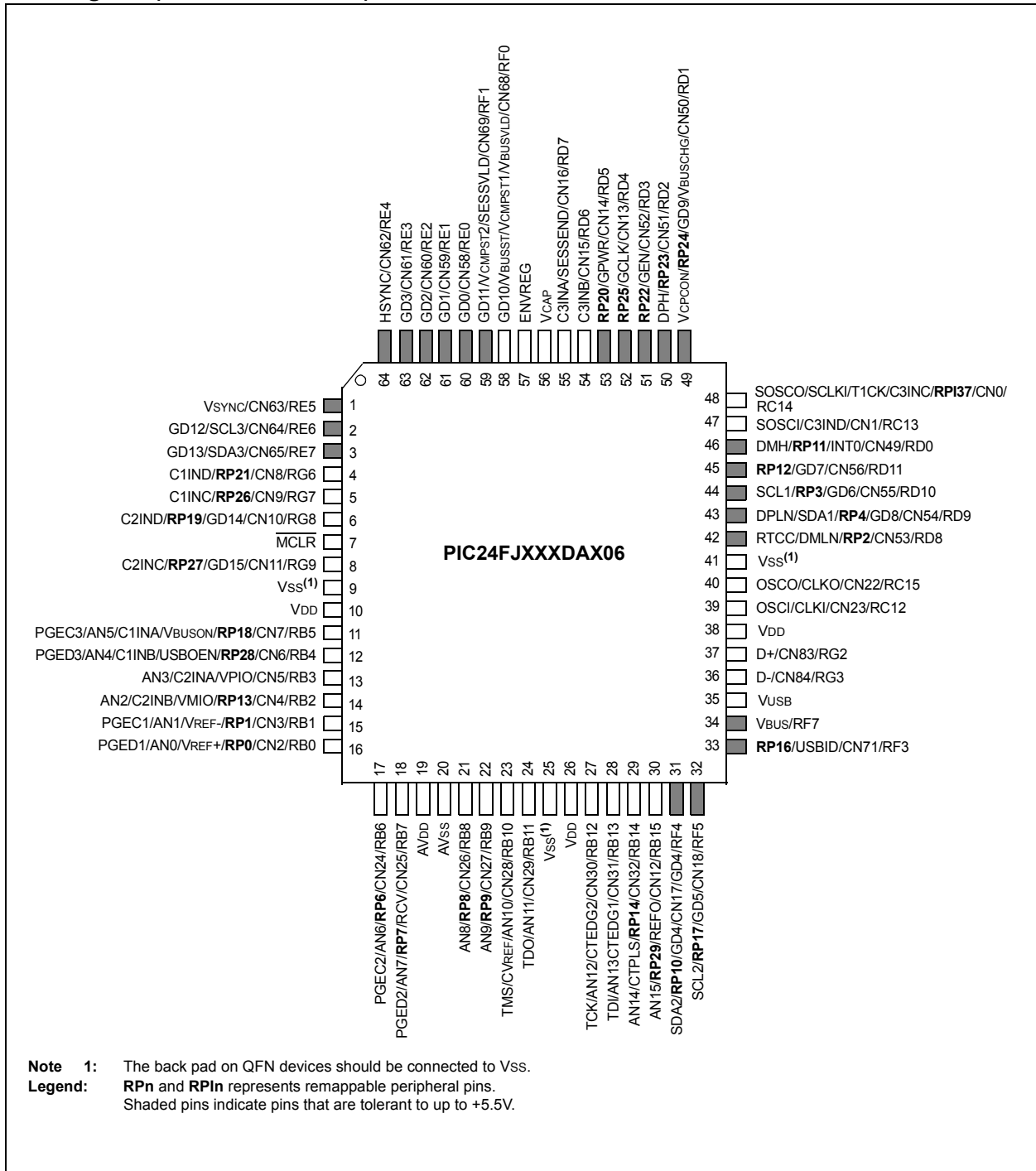

PIC24FJ256DA210 FAMILY

[查询PIC24FJ256DA106供应商](#)

TABLE 1: COMPLETE PIN FUNCTION DESCRIPTIONS FOR 64-PIN DEVICES

| Pin | Function | Pin | Function |
|-----|--|-----|--|
| 1 | Vsync/CN63/RE5 | 33 | RP16 /USBID/CN71/RF3 |
| 2 | GD12/SCL3/CN64/RE6 | 34 | Vbus/RF7 |
| 3 | GD13/SDA3/CN65/RE7 | 35 | Vusb |
| 4 | C1IND/ RP21 /CN8/RG6 | 36 | D-/CN84/RG3 |
| 5 | C1INC/ RP26 /CN9/RG7 | 37 | D+/CN83/RG2 |
| 6 | C2IND/ RP19 /GD14/CN10/RG8 | 38 | VDD |
| 7 | MCLR | 39 | OSCI/CLKI/CN23/RC12 |
| 8 | C2INC/ RP27 /GD15/CN11/RG9 | 40 | OSCO/CLKO/CN22/RC15 |
| 9 | Vss | 41 | Vss |
| 10 | VDD | 42 | RTCC/DMLN/ RP2 /CN53/RD8 |
| 11 | PGEC3/AN5/C1INA/VBUSON/ RP18 /CN7/RB5 | 43 | DPLN/SDA1/ RP4 /GD8/CN54/RD9 |
| 12 | PGED3/AN4/C1INB/USBOEN/ RP28 /CN6/RB4 | 44 | SCL1/ RP3 /GD6/CN55/RD10 |
| 13 | AN3/C2INA/VPIO/CN5/RB3 | 45 | RP12 /GD7/CN56/RD11 |
| 14 | AN2/C2INB/VMIO/ RP13 /CN4/RB2 | 46 | DMH/ RP11 /INT0/CN49/RD0 |
| 15 | PGEC1/AN1/VREF-/ RP1 /CN3/RB1 | 47 | SOSCI/C3IND/CN1/RC13 |
| 16 | PGED1/AN0/VREF+/ RP0 /CN2/RB0 | 48 | SOSCO/SCLKI/T1CK/C3INC/ RP137 /CN0/RC14 |
| 17 | PGEC2/AN6/ RP6 /CN24/RB6 | 49 | VCPCON/ RP24 /GD9/VBUSCHG/CN50/RD1 |
| 18 | PGED2/AN7/ RP7 /RCV/CN25/RB7 | 50 | DPH/ RP23 /CN51/RD2 |
| 19 | AVDD | 51 | RP22 /GEN/CN52/RD3 |
| 20 | AVSS | 52 | RP25 /GCLK/CN13/RD4 |
| 21 | AN8/ RP8 /CN26/RB8 | 53 | RP20 /GPWR/CN14/RD5 |
| 22 | AN9/ RP9 /CN27/RB9 | 54 | C3INB/CN15/RD6 |
| 23 | TMS/CVREF/AN10/CN28/RB10 | 55 | C3INA/SESEND/CN16/RD7 |
| 24 | TDO/AN11/CN29/RB11 | 56 | VCAP |
| 25 | Vss | 57 | ENVREG |
| 26 | VDD | 58 | GD10/VBUSST/VCMPST1/VBUSVLD/CN68/RF0 |
| 27 | TCK/AN12/CTEDG2/CN30/RB12 | 59 | GD11/VCMPST2/SESVLD/CN69/RF1 |
| 28 | TDI/AN13/CTEDG1/CN31/RB13 | 60 | GD0/CN58/RE0 |
| 29 | AN14/CTPLS/ RP14 /CN32/RB14 | 61 | GD1/CN59/RE1 |
| 30 | AN15/ RP29 /REFO/CN12/RB15 | 62 | GD2/CN60/RE2 |
| 31 | SDA2/ RP10 /GD4/CN17/RF4 | 63 | GD3/CN61/RE3 |
| 32 | SCL2/ RP17 /GD5/CN18/RF5 | 64 | HSYNC/CN62/RE4 |

Legend: **RPn** and **RPIn** represent remappable pins for Peripheral Pin Select functions.

PIC24FJ256DA210 FAMILY

查询PIC24FJ256DA106供应商

Pin Diagram (100-Pin TQFP)

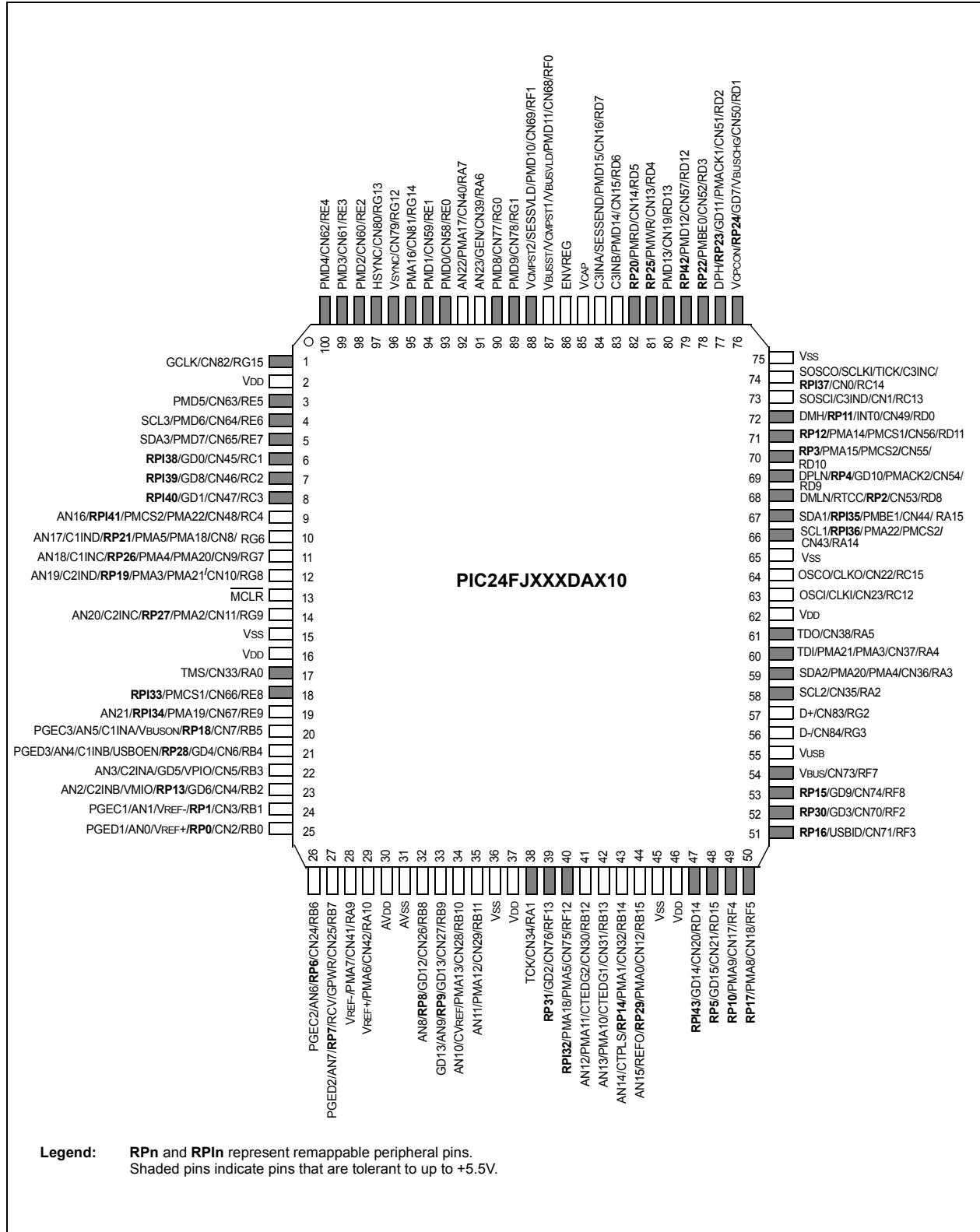

PIC24FJ256DA210 FAMILY

[查询PIC24FJ256DA106供应商](#)

TABLE 2: COMPLETE PIN FUNCTION DESCRIPTIONS FOR 100-PIN DEVICES

| Pin | Function | Pin | Function |
|-----|--|-----|---|
| 1 | GCLK/CN82/RG15 | 41 | AN12/PMA11/CTEDG2/CN30/RB12 |
| 2 | VDD | 42 | AN13/PMA10/CTEDG1/CN31/RB13 |
| 3 | PMD5/CN63/RE5 | 43 | AN14/CTPLS/ RP14 /PMA1/CN32/RB14 |
| 4 | SCL3/PMD6/CN64/RE6 | 44 | AN15/REFO/ RP29 /PMA0/CN12/RB15 |
| 5 | SDA3/PMD7/CN65/RE7 | 45 | VSS |
| 6 | RPI38 /GD0/CN45/RC1 | 46 | VDD |
| 7 | RPI39 /GD8/CN46/RC2 | 47 | RPI43 /GD14/CN20/RD14 |
| 8 | RPI40 /GD1/CN47/RC3 | 48 | RP5 /GD15/CN21/RD15 |
| 9 | AN16/ RPI41 /PMCS2/PMA22 ⁽²⁾ /CN48/RC4 | 49 | RP10 /PMA9/CN17/RF4 |
| 10 | AN17/C1IND/ RP21 /PMA5/PMA18 ⁽²⁾ /CN8/RG6 | 50 | RP17 /PMA8/CN18/RF5 |
| 11 | AN18/C1INC/ RP26 /PMA4/PMA20 ⁽²⁾ /CN9/RG7 | 51 | RP16 /USBID/CN71/RF3 |
| 12 | AN19/C2IND/ RP19 /PMA3/PMA21 ⁽²⁾ /CN10/RG8 | 52 | RP30 /GD3/CN70/RF2 |
| 13 | MCLR | 53 | RP15 /GD9/CN74/RF8 |
| 14 | AN20/C2INC/ RP27 /PMA2/CN11/RG9 | 54 | VBUS/CN73/RF7 |
| 15 | VSS | 55 | VUSB |
| 16 | VDD | 56 | D-/CN84/RG3 |
| 17 | TMS/CN33/RA0 | 57 | D+/CN83/RG2 |
| 18 | RPI33 /PMCS1/CN66/RE8 | 58 | SCL2/CN35/RA2 |
| 19 | AN21/ RPI34 /PMA19/CN67/RE9 | 59 | SDA2/PMA20/PMA4 ⁽²⁾ /CN36/RA3 |
| 20 | PGEC3/AN5/C1INA/VBUSON/ RP18 /CN7/RB5 | 60 | TDI/PMA21/PMA3 ⁽²⁾ /CN37/RA4 |
| 21 | PGED3/AN4/C1INB/USBOEN/ RP28 /GD4/CN6/RB4 | 61 | TDO/CN38/RA5 |
| 22 | AN3/C2INA/GD5/VPIO/CN5/RB3 | 62 | VDD |
| 23 | AN2/C2INB/VMIO/ RP13 /GD6/CN4/RB2 | 63 | OSCI/CLKI/CN23/RC12 |
| 24 | PGEC1/AN1/VREF ⁽¹⁾ / RP1 /CN3/RB1 | 64 | OSCO/CLKO/CN22/RC15 |
| 25 | PGED1/AN0/VREF ⁽¹⁾ / RP0 /CN2/RB0 | 65 | VSS |
| 26 | PGEC2/AN6/ RP6 /CN24/RB6 | 66 | SCL1/ RPI36 /PMA22/PMCS2 ⁽²⁾ /CN43/RA14 |
| 27 | PGED2/AN7/ RP7 /RCV/GPWR/CN25/RB7 | 67 | SDA1/ RPI35 /PMBE1/CN44/RA15 |
| 28 | VREF-/PMA7/CN41/RA9 | 68 | DMLN/RTCC/ RP2 /CN53/RD8 |
| 29 | VREF+/PMA6/CN42/RA10 | 69 | DPLN/ RP4 /GD10/PMACK2/CN54/RD9 |
| 30 | AVDD | 70 | RP3 /PMA15/PMCS2 ⁽³⁾ /CN55/RD10 |
| 31 | AVSS | 71 | RP12 /PMA14/PMCS1 ⁽³⁾ /CN56/RD11 |
| 32 | AN8/ RP8 /GD12/CN26/RB8 | 72 | DMH/ RP11 /INT0/CN49/RD0 |
| 33 | AN9/ RP9 /GD13/CN27/RB9 | 73 | SOSCI/C3IND/CN1/RC13 |
| 34 | AN10/CVREF/PMA13/CN28/RB10 | 74 | SOSCO/SCLKI/T1CK/C3INC/ RPI37 /CN0/RC14 |
| 35 | AN11/PMA12/CN29/RB11 | 75 | VSS |
| 36 | VSS | 76 | VCPCON/ RP24 /GD7/VBUSCHG/CN50/RD1 |
| 37 | VDD | 77 | DPH/ RP23 /GD11/PMACK1/CN51/RD2 |
| 38 | TCK/CN34/RA1 | 78 | RP22 /PMBE0/CN52/RD3 |
| 39 | RP31 /GD2/CN76/RF13 | 79 | RPI42 /PMD12/CN57/RD12 |
| 40 | RPI32 /PMA18/PMA5 ⁽²⁾ /CN75/RF12 | 80 | PMD13/CN19/RD13 |

Legend: **RPn** and **RPI n** represent remappable pins for Peripheral Pin Select (PPS) functions.

- Note**
- 1: Alternate pin assignments for VREF+ and VREF- when the ALTVREF Configuration bit is programmed.
 - 2: Alternate pin assignments for EPMP when the ALTPMP Configuration bit is programmed.
 - 3: Pin assignment for PMCSx when CSF<1:0> is not equal to '00'.

PIC24FJ256DA210 FAMILY

[查询PIC24FJ256DA106供应商](#)

TABLE 2: COMPLETE PIN FUNCTION DESCRIPTIONS FOR 100-PIN DEVICES

| Pin | Function | Pin | Function |
|-----|---------------------------------------|-----|---------------------|
| 81 | RP25 /PMWR/CN13/RD4 | 91 | AN23/GEN/CN39/RA6 |
| 82 | RP20 /PMRD/CN14/RD5 | 92 | AN22/PMA17/CN40/RA7 |
| 83 | C3INB/PMD14/CN15/RD6 | 93 | PMD0/CN58/RE0 |
| 84 | C3INA/SESSEND/PMD15/CN16/RD7 | 94 | PMD1/CN59/RE1 |
| 85 | VCAP | 95 | PMA16/CN81/RG14 |
| 86 | ENVREG | 96 | VSYNC/CN79/RG12 |
| 87 | VBUSST/VCMPST1/VBUSVLD/PMD11/CN68/RF0 | 97 | HSYNC/CN80/RG13 |
| 88 | VCMPST2/SESSVLD/PMD10/CN69/RF1 | 98 | PMD2/CN60/RE2 |
| 89 | PMD9/CN78/RG1 | 99 | PMD3/CN61/RE3 |
| 90 | PMD8/CN77/RG0 | 100 | PMD4/CN62/RE4 |

Legend: **RPn** and **RPin** represent remappable pins for Peripheral Pin Select (PPS) functions.

- Note**
- 1: Alternate pin assignments for VREF+ and VREF- when the **ALTVREF** Configuration bit is programmed.
 - 2: Alternate pin assignments for EPMP when the **ALTPMP** Configuration bit is programmed.
 - 3: Pin assignment for PMCSx when CSF<1:0> is not equal to '00'.

PIC24FJ256DA210 FAMILY

[查询PIC24FJ256DA106供应商](#)

Pin Diagram – Top View (121-Pin BGA)⁽¹⁾

| | 1 | 2 | 3 | 4 | 5 | 6 | 7 | 8 | 9 | 10 | 11 |
|---|-----------------|---------------------|---------------------|----------------|---------------|----------------|----------|----------------|-----------------|-----------------|-----------------|
| A | ● RE4 | ● RE3 | ● HSYNC/ RG13 | ● RE0 | ● RG0 | ● RF1 | ○ ENVREG | ○ N/C | ● RD12 | ● GD11/ RD2 | ● GD7/ RD1 |
| B | ○ N/C | ● GCLK/ RG15 | ● RE2 | ● RE1 | ○ RA7 | ○ RF0 | ○ VCAP | ● RD5 | ● RD3 | ○ Vss | ○ RC14 |
| C | ● RE6 | ○ VDD | ● VSYNC/ RG12 | ● RG14 | ○ GEN/ RA6 | ○ N/C | ○ RD7 | ● RD4 | ○ VDD | ○ RC13 | ● RD11 |
| D | ● GD0/ RC1 | ● RE7 | ○ RE5 | ○ Vss | ○ Vss | ○ N/C | ○ RD6 | ● RD13 | ● RD0 | ○ n/c | ● RD10 |
| E | ○ RC4 | ● GD1/ RC3 | ○ RG6 | ● GD8/ RC2 | ○ VDD | ● RG1 | ○ N/C | ● RA15 | ● RD8 | ● GD10/ RD9 | ● RA14 |
| F | ○ MCLR | ○ RG8 | ○ RG9 | ○ RG7 | ○ Vss | ○ n/c | ○ N/C | ○ VDD | ○ OSCI/ RC12 | ○ Vss | ○ OSCO/ RC15 |
| G | ● RE8 | ○ RE9 | ● RA0 | ○ N/C | ○ VDD | ○ Vss | ○ Vss | ○ N/C | ● RA5 | ● RA3 | ● RA4 |
| H | ○ PGEC3/ RB5 | ○ PGED3/ GD4/RB4 | ○ Vss | ○ VDD | ○ N/C | ○ VDD | ○ n/c | ● VBUS/ RF7 | ○ VUSB | ○ D+/RG2 | ● RA2 |
| J | ○ GD5/ RB3 | ○ GD6/ RB2 | ○ PGED2/RB7 GPWR | ○ AVDD | ○ RB11 | ● RA1 | ○ RB12 | ○ N/C | ○ N/C | ● GD9/RF8 | ○ D-/RG3 |
| K | ○ PGEC1/ RB1 | ○ PGED1/ RB0 | ○ RA10 | ○ GD12/ RB8 | ○ N/C | ● RF12 | ○ RB14 | ○ VDD | ● GD15/ RD15 | ● USBID/ RF3 | ● GD3/ RF2 |
| L | ○ PGEC2/ RB6 | ○ RA9 | ○ AVss | ○ GD13/ RB9 | ○ RB10 | ● GD2/ RF13 | ○ RB13 | ○ RB15 | ● GD14/ RD14 | ● RF4 | ● RF5 |

Note 1: See Table 3 for complete functional pinout descriptions.

Legend: **RPn** and **RPIn** represent remappable pins for Peripheral Pin Select functions.
Shaded pins indicate pins tolerant to up to +5.5V.

PIC24FJ256DA210 FAMILY

查询PIC24FJ256DA106供应商

TABLE 3: COMPLETE PIN FUNCTION DESCRIPTIONS FOR 121-PIN (BGA) DEVICES

| Pin | Function | Pin | Function |
|-----|---|-----|--|
| A1 | PMD4/CN62/RE4 | E5 | VDD |
| A2 | PMD3/CN61/RE3 | E6 | PMD9/CN78/RG1 |
| A3 | HSYNC/CN80/RG13 | E7 | N/C |
| A4 | PMD0/CN58/RE0 | E8 | SDA1/ RPI35 /PMBE1/CN44/RA15 |
| A5 | PMD8/CN77/RG0 | E9 | DMLN/RTCC/ RP2 /CN53/RD8 |
| A6 | VCOMPST2/SESSVLD/PMD10/CN69/RF1 | E10 | DPLN/ RP4 /GD10/PMACK2/CN54/RD9 |
| A7 | ENVREG | E11 | SCL1/ RPI36 /PMA22/PMCS2 ⁽²⁾ /CN43/RA14 |
| A8 | N/C | F1 | MCLR |
| A9 | RPI42 /PMD12/CN57/RD12 | F2 | AN19/C2IND/ RP19 /PMA3/PMA21 ⁽²⁾ /CN10/RG8 |
| A10 | DPH/ RP23 /GD11/PMACK1/CN51/RD2 | F3 | AN20/C2INC/ RP27 /PMA2/CN11/RG9 |
| A11 | VCPCON/ RP24 /GD7/VBUSCHG/CN50/RD1 | F4 | AN18/C1INC/ RP26 /PMA4/PMA20 ⁽²⁾ /CN9/RG7 |
| B1 | N/C | F5 | VSS |
| B2 | GCLK/CN82/RG15 | F6 | N/C |
| B3 | PMD2/CN60/RE2 | F7 | N/C |
| B4 | PMD1/CN59/RE1 | F8 | VDD |
| B5 | AN22/PMA17/CN40/RA7 | F9 | OSCI/CLKI/CN23/RC12 |
| B6 | VBUSST/VCOMPST1/VBUSVLD/PMD11/CN68/RF0 | F10 | VSS |
| B7 | VCAP | F11 | OSCO/CLKO/CN22/RC15 |
| B8 | RP20 /PMRD/CN14/RD5 | G1 | RPI33 /PMCS1/CN66/RE8 |
| B9 | RP22 /PMBE0/CN52/RD3 | G2 | AN21/ RPI34 /PMA19/CN67/RE9 |
| B10 | VSS | G3 | TMS/CN33/RA0 |
| B11 | SOSCO/SCLKI/T1CK/C3INC/ RPI37 /CN0/RC14 | G4 | N/C |
| C1 | SCL3/PMD6/CN64/RE6 | G5 | VDD |
| C2 | VDD | G6 | VSS |
| C3 | VSYNC/CN79/RG12 | G7 | VSS |
| C4 | PMA16/CN81/RG14 | G8 | N/C |
| C5 | AN23/GEN/CN39/RA6 | G9 | TDO/CN38/RA5 |
| C6 | N/C | G10 | SDA2/PMA20/PMA4 ⁽²⁾ /CN36/RA3 |
| C7 | C3INA/SESEND/PMD15/CN16/RD7 | G11 | TDI/PMA21/PMA3 ⁽²⁾ /CN37/RA4 |
| C8 | RP25 /PMWR/CN13/RD4 | H1 | PGEC3/AN5/C1INA/VBUSON/ RP18 /CN7/RB5 |
| C9 | VDD | H2 | PGED3/AN4/C1INB/USBOEN/ RP28 /GD4/CN6/RB4 |
| C10 | SOSCI/C3IND/CN1/RC13 | H3 | VSS |
| C11 | RP12 /PMA14/PMCS1 ⁽³⁾ /CN56/RD11 | H4 | VDD |
| D1 | RPI38 /GD0/CN45/RC1 | H5 | N/C |
| D2 | SDA3/PMD7/CN65/RE7 | H6 | VDD |
| D3 | PMD5/CN63/RE5 | H7 | N/C |
| D4 | VSS | H8 | VBUS/CN73/RF7 |
| D5 | VSS | H9 | VUSB |
| D6 | N/C | H10 | D+/CN83/RG2 |
| D7 | C3INB/PMD14/CN15/RD6 | H11 | SCL2/CN35/RA2 |
| D8 | PMD13/CN19/RD13 | J1 | AN3/C2INA/GD5/VPIO/CN5/RB3 |
| D9 | DMH/ RP11 /INT0/CN49/RD0 | J2 | AN2/C2INB/VMIO/ RP13 /GD6/CN4/RB2 |
| D10 | N/C | J3 | PGED2/AN7/ RP7 /RCV/GPWR/CN25/RB7 |
| D11 | RP3 /PMA15/PMCS2 ⁽³⁾ /CN55/RD10 | J4 | AVDD |
| E1 | AN16/ RPI41 /PMCS2/PMA22 ⁽²⁾ /CN48/RC4 | J5 | AN11/PMA12/CN29/RB11 |
| E2 | RPI40 /GD1/CN47/RC3 | J6 | TCK/CN34/RA1 |
| E3 | AN17/C1IND/ RP21 /PMA5/PMA18 ⁽²⁾ /CN8/RG6 | J7 | AN12/PMA11/CTEDG2/CN30/RB12 |
| E4 | RPI39 /GD8/CN46/RC2 | J8 | N/C |

- Legend:** RPN and RPin represent remappable pins for Peripheral Pin Select functions.
- Note**
- 1: Alternate pin assignments for VREF+ and VREF- when the ALTVREF Configuration bit is programmed.
 - 2: Alternate pin assignments for EPMP when the ALTPMP Configuration bit is programmed.
 - 3: Pin assignment for PMCSx when CSF<1:0> is not equal to '00'.

PIC24FJ256DA210 FAMILY

查询PIC24FJ256DA106供应商

TABLE 3: COMPLETE PIN FUNCTION DESCRIPTIONS FOR 121-PIN (BGA) DEVICES

| Pin | Function | Pin | Function |
|-----|---|-----|--|
| J9 | N/C | L1 | PGEC2/AN6/ RP6 /CN24/RB6 |
| J10 | RP15 /GD9/CN74/RF8 | L2 | VREF ⁽¹⁾ /PMA7/CN41/RA9 |
| J11 | D-/CN84/RG3 | L3 | AVSS |
| K1 | PGEC1/AN1/VREF ⁽¹⁾ / RP1 /CN3/RB1 | L4 | AN9/ RP9 /GD13/CN27/RB9 |
| K2 | PGED1/AN0/VREF ⁽¹⁾ / RP0 /CN2/RB0 | L5 | AN10/CVREF/PMA13/CN28/RB10 |
| K3 | VREF ⁽¹⁾ /PMA6/CN42/RA10 | L6 | RP31 /GD2/CN76/RF13 |
| K4 | AN8/ RP8 /GD12/CN26/RB8 | L7 | AN13/PMA10/CTEDG1/CN31/RB13 |
| K5 | N/C | L8 | AN15/REFO/ RP29 /PMA0/CN12/RB15 |
| K6 | RP32 /PMA18/PMA5 ⁽²⁾ /CN75/RF12 | L9 | RPI43 /GD14/CN20/RD14 |
| K7 | AN14/CTPLS/ RP14 /PMA1/CN32/RB14 | L10 | RP10 /PMA9/CN17/RF4 |
| K8 | VDD | L11 | RP17 /GD5/PMA8/SCL2/CN18/RF5 |
| K9 | RP5 /GD15/CN21/RD15 | — | — |
| K10 | RP16 /USBID/CN71/RF3 | — | — |
| K11 | RP30 /GD3/CN70/RF2 | — | — |

Legend: **RPn** and **RPin** represent remappable pins for Peripheral Pin Select functions.

- Note**
- 1: Alternate pin assignments for VREF+ and VREF- when the ALTVREF Configuration bit is programmed.
 - 2: Alternate pin assignments for EPMP when the ALTPMP Configuration bit is programmed.
 - 3: Pin assignment for PMCSx when CSF<1:0> is not equal to '00'.

PIC24FJ256DA210 FAMILY

[查询PIC24FJ256DA106供应商](#)

Table of Contents

| | | |
|------|---|-----|
| 1.0 | Device Overview | 15 |
| 2.0 | Guidelines for Getting Started with 16-bit Microcontrollers | 33 |
| 3.0 | CPU | 39 |
| 4.0 | Memory Organization | 45 |
| 5.0 | Flash Program Memory | 81 |
| 6.0 | Resets | 87 |
| 7.0 | Interrupt Controller | 93 |
| 8.0 | Oscillator Configuration | 141 |
| 9.0 | Power-Saving Features | 155 |
| 10.0 | I/O Ports | 157 |
| 11.0 | Timer1 | 189 |
| 12.0 | Timer2/3 and Timer4/5 | 191 |
| 13.0 | Input Capture with Dedicated Timers | 197 |
| 14.0 | Output Compare with Dedicated Timers | 201 |
| 15.0 | Serial Peripheral Interface (SPI) | 211 |
| 16.0 | Inter-Integrated Circuit™ (I ² C™) | 223 |
| 17.0 | Universal Asynchronous Receiver Transmitter (UART) | 231 |
| 18.0 | Universal Serial Bus with On-The-Go Support (USB OTG) | 239 |
| 19.0 | Enhanced Parallel Master Port (EPMP) | 273 |
| 20.0 | Real-Time Clock and Calendar (RTCC) | 285 |
| 21.0 | 32-Bit Programmable Cyclic Redundancy Check (CRC) Generator | 297 |
| 22.0 | Graphics Controller Module (GFX) | 305 |
| 23.0 | 10-Bit High-Speed A/D Converter | 325 |
| 24.0 | Triple Comparator Module | 335 |
| 25.0 | Comparator Voltage Reference | 341 |
| 26.0 | Charge Time Measurement Unit (CTMU) | 343 |
| 27.0 | Special Features | 347 |
| 28.0 | Development Support | 359 |
| 29.0 | Instruction Set Summary | 363 |
| 30.0 | Electrical Characteristics | 371 |
| 31.0 | Packaging Information | 387 |
| | Appendix A: Revision History | 397 |
| | Index | 399 |
| | The Microchip Web Site | 405 |
| | Customer Change Notification Service | 405 |
| | Customer Support | 405 |
| | Reader Response | 406 |
| | Product Identification System | 407 |

PIC24FJ256DA210 FAMILY

[查询PIC24FJ256DA106供应商](#)

TO OUR VALUED CUSTOMERS

It is our intention to provide our valued customers with the best documentation possible to ensure successful use of your Microchip products. To this end, we will continue to improve our publications to better suit your needs. Our publications will be refined and enhanced as new volumes and updates are introduced.

If you have any questions or comments regarding this publication, please contact the Marketing Communications Department via E-mail at docerrors@microchip.com or fax the **Reader Response Form** in the back of this data sheet to (480) 792-4150. We welcome your feedback.

Most Current Data Sheet

To obtain the most up-to-date version of this data sheet, please register at our Worldwide Web site at:

<http://www.microchip.com>

You can determine the version of a data sheet by examining its literature number found on the bottom outside corner of any page. The last character of the literature number is the version number, (e.g., DS30000A is version A of document DS30000).

Errata

An errata sheet, describing minor operational differences from the data sheet and recommended workarounds, may exist for current devices. As device/documentation issues become known to us, we will publish an errata sheet. The errata will specify the revision of silicon and revision of document to which it applies.

To determine if an errata sheet exists for a particular device, please check with one of the following:

- Microchip's Worldwide Web site; <http://www.microchip.com>
- Your local Microchip sales office (see last page)

When contacting a sales office, please specify which device, revision of silicon and data sheet (include literature number) you are using.

Customer Notification System

Register on our web site at www.microchip.com to receive the most current information on all of our products.

PIC24FJ256DA210 FAMILY

[查询PIC24FJ256DA106供应商](#)

1.0 DEVICE OVERVIEW

This document contains device-specific information for the following devices:

- PIC24FJ128DA106
- PIC24FJ128DA206
- PIC24FJ256DA106
- PIC24FJ256DA206
- PIC24FJ128DA110
- PIC24FJ128DA210
- PIC24FJ256DA110
- PIC24FJ256DA210

The PIC24FJ256DA210 family enhances on the existing line of Microchip's 16-bit microcontrollers, adding a new Graphics Controller (GFX) module to interface with a graphical LCD display and also adds large data RAM, up to 96 Kbytes. The PIC24FJ256DA210 family allows the CPU to fetch data directly from an external memory device using the EPMP module.

1.1 Core Features

1.1.1 16-BIT ARCHITECTURE

Central to all PIC24F devices is the 16-bit modified Harvard architecture, first introduced with Microchip's dsPIC[®] Digital Signal Controllers (DSCs). The PIC24F CPU core offers a wide range of enhancements, such as:

- 16-bit data and 24-bit address paths with the ability to move information between data and memory spaces
- Linear addressing of up to 12 Mbytes (program space) and 32 Kbytes (data)
- A 16-element working register array with built-in software stack support
- A 17 x 17 hardware multiplier with support for integer math
- Hardware support for 32 by 16-bit division
- An instruction set that supports multiple addressing modes and is optimized for high-level languages, such as 'C'
- Operational performance up to 16 MIPS

1.1.2 POWER-SAVING TECHNOLOGY

All of the devices in the PIC24FJ256DA210 family incorporate a range of features that can significantly reduce power consumption during operation. Key items include:

- **On-the-Fly Clock Switching:** The device clock can be changed under software control to the Timer1 source or the internal, low-power RC oscillator during operation, allowing the user to incorporate power-saving ideas into their software designs.

- **Doze Mode Operation:** When timing-sensitive applications, such as serial communications, require the uninterrupted operation of peripherals, the CPU clock speed can be selectively reduced, allowing incremental power savings without missing a beat.
- **Instruction-Based Power-Saving Modes:** The microcontroller can suspend all operations, or selectively shut down its core while leaving its peripherals active with a single instruction in software.

1.1.3 OSCILLATOR OPTIONS AND FEATURES

All of the devices in the PIC24FJ256DA210 family offer five different oscillator options, allowing users a range of choices in developing application hardware. These include:

- Two Crystal modes using crystals or ceramic resonators.
- Two External Clock modes offering the option of a divide-by-2 clock output.
- A Fast Internal Oscillator (FRC) with a nominal 8 MHz output, which can also be divided under software control to provide clock speeds as low as 31 kHz.
- A Phase Lock Loop (PLL) frequency multiplier, available to the external oscillator modes and the FRC oscillator, which allows clock speeds of up to 32 MHz.
- A separate Low-Power Internal RC Oscillator (LPRC) with a fixed 31 kHz output, which provides a low-power option for timing-insensitive applications.

The internal oscillator block also provides a stable reference source for the Fail-Safe Clock Monitor (FSCM). This option constantly monitors the main clock source against a reference signal provided by the internal oscillator and enables the controller to switch to the internal oscillator, allowing for continued low-speed operation or a safe application shutdown.

1.1.4 EASY MIGRATION

Regardless of the memory size, all devices share the same rich set of peripherals, allowing for a smooth migration path as applications grow and evolve. The consistent pinout scheme used throughout the entire family also aids in migrating from one device to the next larger, or even in jumping from 64-pin to 100-pin devices.

The PIC24F family is pin compatible with devices in the dsPIC33 family, and shares some compatibility with the pinout schema for PIC18 and dsPIC30. This extends the ability of applications to grow from the relatively simple, to the powerful and complex, yet still selecting a Microchip device.

PIC24FJ256DA210 FAMILY

[查询PIC24FJ256DA106供应商](#)

1.2 Graphics Controller

With the PIC24FJ256DA210 family of devices, Microchip introduces the Graphics Controller module, which acts as an interface between the CPU (mainly through SFRs) and a display. On-board RAM is provided for display buffer, scratch areas, images and fonts. In some cases, the RAM requirements for the display used exceeds the on-board RAM; external memory connected through EPMP can be used.

This module provides acceleration for drawing points, vertical and horizontal lines, rectangles, copying rectangles between different locations on screen, drawing text and decompressing compressed data.

1.3 USB On-The-Go

The USB On-The-Go (USB OTG) module provides on-chip functionality as a target device compatible with the USB 2.0 standard, as well as limited stand-alone functionality as a USB embedded host. By implementing USB Host Negotiation Protocol (HNP), the module can also dynamically switch between device and host operation, allowing for a much wider range of versatile USB enabled applications on a microcontroller platform.

In addition to USB host functionality, PIC24FJ256DA210 family devices provide a true single chip USB solution, including an on-chip transceiver and voltage regulator, and a voltage boost generator for sourcing bus power during host operations.

1.4 Other Special Features

- **Peripheral Pin Select:** The Peripheral Pin Select (PPS) feature allows most digital peripherals to be mapped over a fixed set of digital I/O pins. Users may independently map the input and/or output of any one of the many digital peripherals to any one of the I/O pins.
- **Communications:** The PIC24FJ256DA210 family incorporates a range of serial communication peripherals to handle a range of application requirements. There are three independent I²C™ modules that support both Master and Slave modes of operation. Devices also have, through the PPS feature, four independent UARTs with built-in IrDA® encoders/decoders and three SPI modules.
- **Analog Features:** All members of the PIC24FJ256DA210 family include a 10-bit A/D Converter (ADC) module and a triple comparator module. The ADC module incorporates programmable acquisition time, allowing for a channel to be selected and a conversion to be initiated without waiting for a sampling period, and faster sampling speeds. The comparator module includes three analog comparators that are configurable for a wide range of operations.
- **CTMU Interface:** In addition to their other analog features, members of the PIC24FJ256DA210 family include the CTMU interface module. This provides a convenient method for precision time measurement and pulse generation, and can serve as an interface for capacitive sensors.
- **Enhanced Parallel Master/Parallel Slave Port:** There are general purpose I/O ports, which can be configured for parallel data communications. In this mode, the device can be master or slave on the communication bus. 4-bit, 8-bit and 16-bit data transfers, with up to 23 external address lines are supported in Master modes.
- **Real-Time Clock and Calendar: (RTCC)** This module implements a full-featured clock and calendar with alarm functions in hardware, freeing up timer resources and program memory space for use of the core application.

PIC24FJ256DA210 FAMILY

[查询PIC24FJ256DA106供应商](#)

1.5 Details on Individual Family Members

Devices in the PIC24FJ256DA210 family are available in 64-pin and 100-pin packages. The general block diagram for all devices is shown in Figure 1-1.

The devices are differentiated from each other in seven ways:

1. Flash program memory (128 Kbytes for PIC24FJ128DAXXX devices and 256 Kbytes for PIC24FJ256DAXXX devices).
2. Data memory (24 Kbytes for PIC24FJXXXDA1XX devices, and 96 Kbytes for PIC24FJXXXDA2XX devices).
3. Available I/O pins and ports (52 pins on 6 ports for PIC24FJXXXDAX06 devices and 84 pins on 7 ports for PIC24FJXXXDAX10 devices).
4. Available Interrupt-on-Change Notification (ICN) inputs (52 on PIC24FJXXXDAX06 devices and 84 on PIC24FJXXXDAX10 devices).

5. Available remappable pins (29 pins on PIC24FJXXXDAX06 devices and 44 pins on PIC24FJXXXDAX10 devices).
6. Analog channels for ADC (16 channels for PIC24FJXXXDAX06 devices and 24 channels for PIC24FJxxxDAx10 devices).
7. EPMP module (available in PIC24FJXXXDAX10 devices and not in PIC24FJXXXDAX06 devices).

All other features for devices in this family are identical. These are summarized in Table 1-1 and Table 1-2.

A list of the pin features available on the PIC24FJ256DA210 family devices, sorted by function, is shown in Table 1-1. Note that this table shows the pin location of individual peripheral features and not how they are multiplexed on the same pin. This information is provided in the pinout diagrams in the beginning of the data sheet. Multiplexed features are sorted by the priority given to a feature, with the highest priority peripheral being listed first.

PIC24FJ256DA210 FAMILY

[查询PIC24FJ256DA106供应商](#)

TABLE 1-1: DEVICE FEATURES FOR THE PIC24FJ256DA210 FAMILY: 64-PIN

| Features | PIC24FJ128DA106 | PIC24FJ256DA106 | PIC24FJ128DA206 | PIC24FJ256DA206 |
|---|---|-----------------|-----------------|-----------------|
| Operating Frequency | DC – 32 MHz | | | |
| Program Memory (bytes) | 128K | 256K | 128K | 256K |
| Program Memory (instructions) | 44,032 | 87,552 | 44,032 | 87,552 |
| Data Memory (bytes) | 24K | | 96K | |
| Interrupt Sources (soft vectors/ NMI traps) | 65 (61/4) | | | |
| I/O Ports | Ports B, C, D, E, F, G | | | |
| Total I/O Pins | 52 | | | |
| Remappable Pins | 29 (28 I/O, 1 Input only) | | | |
| Timers: | | | | |
| Total Number (16-bit) | 5 ⁽¹⁾ | | | |
| 32-Bit (from paired 16-bit timers) | 2 | | | |
| Input Capture Channels | 9 ⁽¹⁾ | | | |
| Output Compare/PWM Channels | 9 ⁽¹⁾ | | | |
| Input Change Notification Interrupt | 52 | | | |
| Serial Communications: | | | | |
| UART | 4 ⁽¹⁾ | | | |
| SPI (3-wire/4-wire) | 3 ⁽¹⁾ | | | |
| I ² C™ | 3 | | | |
| Parallel Communications (EPMP/PSP) | No | | | |
| JTAG Boundary Scan | Yes | | | |
| 10-Bit Analog-to-Digital Converter (ADC) Module (input channels) | 16 | | | |
| Analog Comparators | 3 | | | |
| CTMU Interface | Yes | | | |
| USB OTG | Yes | | | |
| Graphics Controller | Yes | | | |
| Resets (and Delays) | POR, BOR, RESET Instruction, MCLR, WDT; Illegal Opcode, REPEAT Instruction, Hardware Traps, Configuration Word Mismatch (OST, PLL Lock) | | | |
| Instruction Set | 76 Base Instructions, Multiple Addressing Mode Variations | | | |
| Packages | 64-Pin TQFP and QFN | | | |

Note 1: Peripherals are accessible through remappable pins.

PIC24FJ256DA210 FAMILY

[查询PIC24FJ256DA106供应商](#)

TABLE 1-2: DEVICE FEATURES FOR THE PIC24FJ256DA210 FAMILY: 100-PIN DEVICES

| Features | PIC24FJ128DA110 | PIC24FJ256DA110 | PIC24FJ128DA210 | PIC24FJ256DA210 |
|--|---|-----------------|-----------------|-----------------|
| Operating Frequency | DC – 32 MHz | | | |
| Program Memory (bytes) | 128K | 256K | 128K | 256K |
| Program Memory (instructions) | 44,032 | 87,552 | 44,032 | 87,552 |
| Data Memory (bytes) | 24K | | 96K | |
| Interrupt Sources (soft vectors/NMI traps) | 66 (62/4) | | | |
| I/O Ports | Ports A, B, C, D, E, F, G | | | |
| Total I/O Pins | 84 | | | |
| Remappable Pins | 44 (32 I/O, 12 input only) | | | |
| Timers: | | | | |
| Total Number (16-bit) | 5 ⁽¹⁾ | | | |
| 32-Bit (from paired 16-bit timers) | 2 | | | |
| Input Capture Channels | 9 ⁽¹⁾ | | | |
| Output Compare/PWM Channels | 9 ⁽¹⁾ | | | |
| Input Change Notification Interrupt | 84 | | | |
| Serial Communications: | | | | |
| UART | 4 ⁽¹⁾ | | | |
| SPI (3-wire/4-wire) | 3 ⁽¹⁾ | | | |
| I ² C™ | 3 | | | |
| Parallel Communications (EPMP/PSP) | Yes | | | |
| JTAG Boundary Scan | Yes | | | |
| 10-Bit Analog-to-Digital Converter (ADC) Module (input channels) | 24 | | | |
| Analog Comparators | 3 | | | |
| CTMU Interface | Yes | | | |
| USB OTG | Yes | | | |
| Graphics Controller | Yes | | | |
| Resets (and delays) | POR, BOR, RESET Instruction, MCLR, WDT; Illegal Opcode, REPEAT Instruction, Hardware Traps, Configuration Word Mismatch (OST, PLL Lock) | | | |
| Instruction Set | 76 Base Instructions, Multiple Addressing Mode Variations | | | |
| Packages | 100-Pin TQFP and 121-Pin BGA | | | |

Note 1: Peripherals are accessible through remappable pins.

PIC24FJ256DA210 FAMILY

查询PIC24FJ256DA106供应商

FIGURE 1-1: PIC24FJ256DA210 FAMILY GENERAL BLOCK DIAGRAM

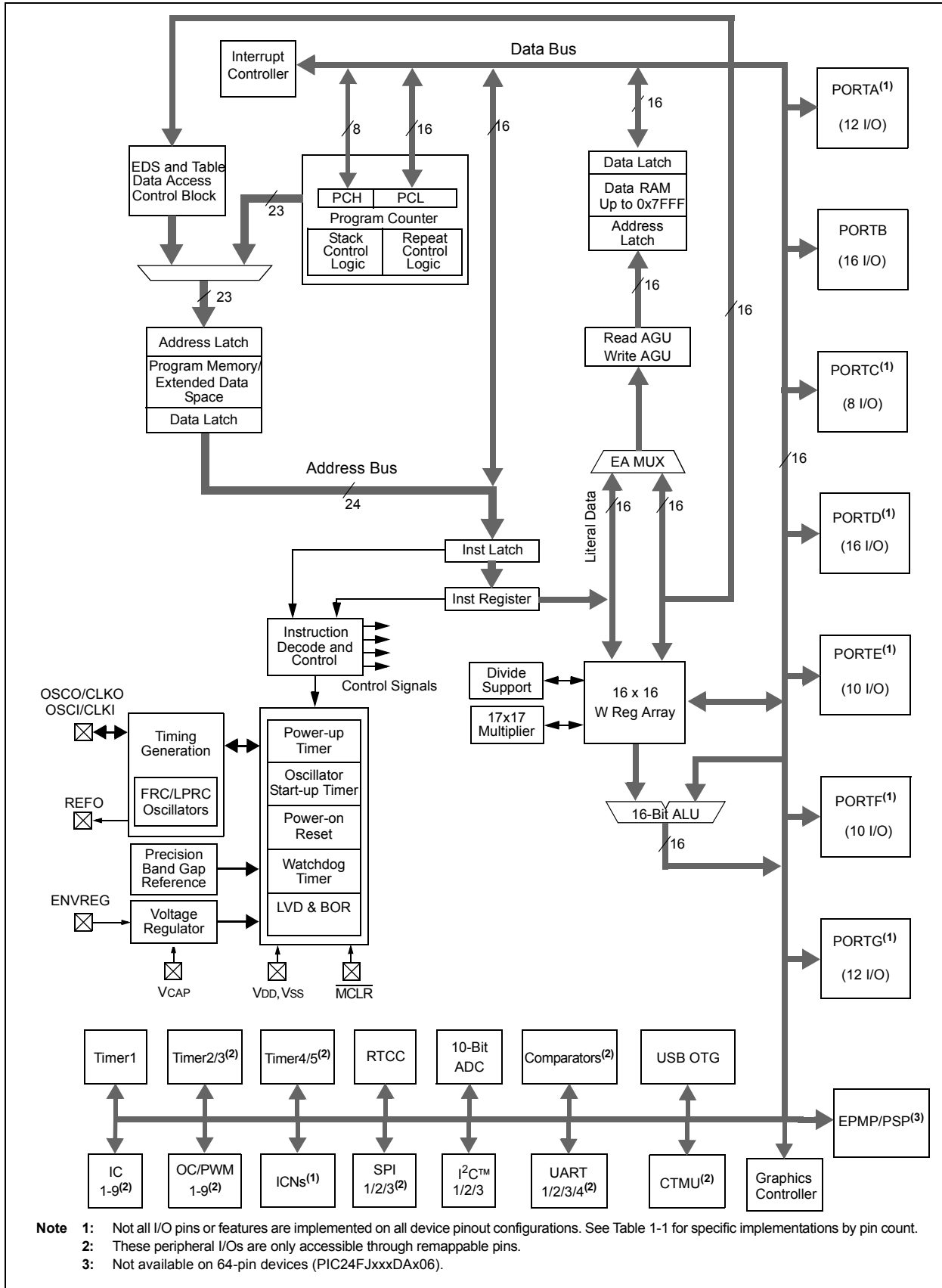

PIC24FJ256DA210 FAMILY

[查询PIC24FJ256DA106供应商](#)

TABLE 1-3: PIC24FJ256DA210 FAMILY PINOUT DESCRIPTIONS

| Function | Pin Number | | | I/O | Input Buffer | Description |
|----------|-----------------|--------------|-------------|-----|--------------|--------------------------------------|
| | 64-Pin TQFP/QFN | 100-Pin TQFP | 121-Pin BGA | | | |
| AN0 | 16 | 25 | K2 | I | ANA | A/D Analog Inputs. |
| AN1 | 15 | 24 | K1 | I | ANA | |
| AN2 | 14 | 23 | J2 | I | ANA | |
| AN3 | 13 | 22 | J1 | I | ANA | |
| AN4 | 12 | 21 | H2 | I | ANA | |
| AN5 | 11 | 20 | H1 | I | ANA | |
| AN6 | 17 | 26 | L1 | I | ANA | |
| AN7 | 18 | 27 | J3 | I | ANA | |
| AN8 | 21 | 32 | K4 | I | ANA | |
| AN9 | 22 | 33 | L4 | I | ANA | |
| AN10 | 23 | 34 | L5 | I | ANA | |
| AN11 | 24 | 35 | J5 | I | ANA | |
| AN12 | 27 | 41 | J7 | I | ANA | |
| AN13 | 28 | 42 | L7 | I | ANA | |
| AN14 | 29 | 43 | K7 | I | ANA | |
| AN15 | 30 | 44 | L8 | I | ANA | |
| AN16 | — | 9 | E1 | I | ANA | |
| AN17 | — | 10 | E3 | I | ANA | |
| AN18 | — | 11 | F4 | I | ANA | |
| AN19 | — | 12 | F2 | I | ANA | |
| AN20 | — | 14 | F3 | I | ANA | |
| AN21 | — | 19 | G2 | I | ANA | |
| AN22 | — | 92 | B5 | I | ANA | |
| AN23 | — | 91 | C5 | I | ANA | |
| AVDD | 19 | 30 | J4 | P | — | Positive Supply for Analog modules. |
| AVSS | 20 | 31 | L3 | P | — | Ground Reference for Analog modules. |
| C1INA | 11 | 20 | H1 | I | ANA | Comparator 1 Input A. |
| C1INB | 12 | 21 | H2 | I | ANA | Comparator 1 Input B. |
| C1INC | 5 | 11 | F4 | I | ANA | Comparator 1 Input C. |
| C1IND | 4 | 10 | E3 | I | ANA | Comparator 1 Input D. |
| C2INA | 13 | 22 | J1 | I | ANA | Comparator 2 Input A. |
| C2INB | 14 | 23 | J2 | I | ANA | Comparator 2 Input B. |
| C2INC | 8 | 14 | F3 | I | ANA | Comparator 2 Input C. |
| C2IND | 6 | 12 | F2 | I | ANA | Comparator 2 Input D. |
| C3INA | 55 | 84 | C7 | I | ANA | Comparator 3 Input A. |
| C3INB | 54 | 83 | D7 | I | ANA | Comparator 3 Input B. |
| C3INC | 48 | 74 | B11 | I | ANA | Comparator 3 Input C. |
| C3IND | 47 | 73 | C10 | I | ANA | Comparator 3 Input D. |
| CLKI | 39 | 63 | F9 | I | ST | Main Clock Input Connection. |
| CLKO | 40 | 64 | F11 | O | — | System Clock Output. |

Legend: TTL = TTL input buffer
ANA = Analog level input/output
ST = Schmitt Trigger input buffer
I²C™ = I²C/SMBus input buffer

- Note**
- 1: The alternate EPMP pins are selected when the $\overline{\text{ALTPMP}}$ (CW3<12>) bit is programmed to '0'.
 - 2: The PMSC2 signal will replace the PMA15 signal on the 15-pin PMA when CSF<1:0> = 01 or 10.
 - 3: The PMCS1 signal will replace the PMA14 signal on the 14-pin PMA when CSF<1:0> = 10.
 - 4: The alternate VREF pins selected when the ALTVREF (CW1<5>) bit is programmed to '0'.

PIC24FJ256DA210 FAMILY

查询PIC24FJ256DA106供应商

TABLE 1-3: PIC24FJ256DA210 FAMILY PINOUT DESCRIPTIONS (CONTINUED)

| Function | Pin Number | | | I/O | Input Buffer | Description |
|----------|--------------------|-----------------|----------------|-----|--------------|-----------------------------|
| | 64-Pin TQFP/QFN | 100-Pin TQFP | 121-Pin BGA | | | |
| CN0 | 48 | 74 | B11 | I | ST | Interrupt-on-Change Inputs. |
| CN1 | 47 | 73 | C10 | I | ST | |
| CN2 | 16 | 25 | K2 | I | ST | |
| CN3 | 15 | 24 | K1 | I | ST | |
| CN4 | 14 | 23 | J2 | I | ST | |
| CN5 | 13 | 22 | J1 | I | ST | |
| CN6 | 12 | 21 | H2 | I | ST | |
| CN7 | 11 | 20 | H1 | I | ST | |
| CN8 | 4 | 10 | E3 | I | ST | |
| CN9 | 5 | 11 | F4 | I | ST | |
| CN10 | 6 | 12 | F2 | I | ST | |
| CN11 | 8 | 14 | F3 | I | ST | |
| CN12 | 30 | 44 | L8 | I | ST | |
| CN13 | 52 | 81 | C8 | I | ST | |
| CN14 | 53 | 82 | B8 | I | ST | |
| CN15 | 54 | 83 | D7 | I | ST | |
| CN16 | 55 | 84 | C7 | I | ST | |
| CN17 | 31 | 49 | L10 | I | ST | |
| CN18 | 32 | 50 | L11 | I | ST | |
| CN19 | — | 80 | D8 | I | ST | |
| CN20 | — | 47 | L9 | I | ST | |
| CN21 | — | 48 | K9 | I | ST | |
| CN22 | 40 | 64 | F11 | I | ST | |
| CN23 | 39 | 63 | F9 | I | ST | |
| CN24 | 17 | 26 | L1 | I | ST | |
| CN25 | 18 | 27 | J3 | I | ST | |
| CN26 | 21 | 32 | K4 | I | ST | |
| CN27 | 22 | 33 | L4 | I | ST | |
| CN28 | 23 | 34 | L5 | I | ST | |
| CN29 | 24 | 35 | J5 | I | ST | |
| CN30 | 27 | 41 | J7 | I | ST | |
| CN31 | 28 | 42 | L7 | I | ST | |
| CN32 | 29 | 43 | K7 | I | ST | |
| CN33 | — | 17 | G3 | I | ST | |
| CN34 | — | 38 | J6 | I | ST | |
| CN35 | — | 58 | H11 | I | ST | |
| CN36 | — | 59 | G10 | I | ST | |
| CN37 | — | 60 | G11 | I | ST | |
| CN38 | — | 61 | G9 | I | ST | |
| CN39 | — | 91 | C5 | I | ST | |

Legend: TTL = TTL input buffer
ANA = Analog level input/output

ST = Schmitt Trigger input buffer
 I^2C^{TM} = I^2C /SMBus input buffer

- Note** 1: The alternate EPMP pins are selected when the ALTPMP (CW3<12>) bit is programmed to '0'.
2: The PMSC2 signal will replace the PMA15 signal on the 15-pin PMA when CSF<1:0> = 01 or 10.
3: The PMCS1 signal will replace the PMA14 signal on the 14-pin PMA when CSF<1:0> = 10.
4: The alternate VREF pins selected when the ALTVREF (CW1<5>) bit is programmed to '0'.

PIC24FJ256DA210 FAMILY

[查询PIC24FJ256DA106供应商](#)

TABLE 1-3: PIC24FJ256DA210 FAMILY PINOUT DESCRIPTIONS (CONTINUED)

| Function | Pin Number | | | I/O | Input Buffer | Description |
|----------|--------------------|-----------------|----------------|-----|--------------|-----------------------------|
| | 64-Pin TQFP/QFN | 100-Pin TQFP | 121-Pin BGA | | | |
| CN40 | — | 92 | B5 | I | ST | Interrupt-on-Change Inputs. |
| CN41 | — | 28 | L2 | I | ST | |
| CN42 | — | 29 | K3 | I | ST | |
| CN43 | — | 66 | E11 | I | ST | |
| CN44 | — | 67 | E8 | I | ST | |
| CN45 | — | 6 | D1 | I | ST | |
| CN46 | — | 7 | E4 | I | ST | |
| CN47 | — | 8 | E2 | I | ST | |
| CN48 | — | 9 | E1 | I | ST | |
| CN49 | 46 | 72 | D9 | I | ST | |
| CN50 | 49 | 76 | A11 | I | ST | |
| CN51 | 50 | 77 | A10 | I | ST | |
| CN52 | 51 | 78 | B9 | I | ST | |
| CN53 | 42 | 68 | E9 | I | ST | |
| CN54 | 43 | 69 | E10 | I | ST | |
| CN55 | 44 | 70 | D11 | I | ST | |
| CN56 | 45 | 71 | C11 | I | ST | |
| CN57 | — | 79 | A9 | I | ST | |
| CN58 | 60 | 93 | A4 | I | ST | |
| CN59 | 61 | 94 | B4 | I | ST | |
| CN60 | 62 | 98 | B3 | I | ST | |
| CN61 | 63 | 99 | A2 | I | ST | |
| CN62 | 64 | 100 | A1 | I | ST | |
| CN63 | 1 | 3 | D3 | I | ST | |
| CN64 | 2 | 4 | C1 | I | ST | |
| CN65 | 3 | 5 | D2 | I | ST | |
| CN66 | — | 18 | G1 | I | ST | |
| CN67 | — | 19 | G2 | I | ST | |
| CN68 | 58 | 87 | B6 | I | ST | |
| CN69 | 59 | 88 | A6 | I | ST | |
| CN70 | — | 52 | K11 | I | ST | |
| CN71 | 33 | 51 | K10 | I | ST | |
| CN73 | — | 54 | H8 | I | ST | |
| CN74 | — | 53 | J10 | I | ST | |
| CN75 | — | 40 | K6 | I | ST | |
| CN76 | — | 39 | L6 | I | ST | |
| CN77 | — | 90 | A5 | I | ST | |
| CN78 | — | 89 | E6 | I | ST | |
| CN79 | — | 96 | C3 | I | ST | |
| CN80 | — | 97 | A3 | I | ST | |

Legend: TTL = TTL input buffer ST = Schmitt Trigger input buffer
ANA = Analog level input/output I²C™ = I²C/SMBus input buffer

Note 1: The alternate EPMP pins are selected when the ALTPMP (CW3<12>) bit is programmed to '0'.
2: The PMSC2 signal will replace the PMA15 signal on the 15-pin PMA when CSF<1:0> = 01 or 10.
3: The PMCS1 signal will replace the PMA14 signal on the 14-pin PMA when CSF<1:0> = 10.
4: The alternate VREF pins selected when the ALTVREF (CW1<5>) bit is programmed to '0'.

PIC24FJ256DA210 FAMILY

查询PIC24FJ256DA106供应商

TABLE 1-3: PIC24FJ256DA210 FAMILY PINOUT DESCRIPTIONS (CONTINUED)

| Function | Pin Number | | | I/O | Input Buffer | Description |
|----------|-----------------|--------------|-------------|-----|--------------|---|
| | 64-Pin TQFP/QFN | 100-Pin TQFP | 121-Pin BGA | | | |
| CN81 | — | 95 | C4 | I | ST | Interrupt-on-Change Inputs. |
| CN82 | — | 1 | B2 | I | ST | |
| CN83 | 37 | 57 | H10 | I | ST | |
| CN84 | 36 | 56 | J11 | I | ST | |
| CTEDG1 | 28 | 42 | L7 | I | ANA | CTMU External Edge Input 1. |
| CTEDG2 | 27 | 41 | J7 | I | ANA | CTMU External Edge Input 2. |
| CTPLS | 29 | 43 | K7 | O | — | CTMU Pulse Output. |
| CVREF | 23 | 34 | L5 | O | — | Comparator Voltage Reference Output. |
| D+ | 37 | 57 | H10 | I/O | — | USB Differential Plus Line (internal transceiver). |
| D- | 36 | 56 | J11 | I/O | — | USB Differential Minus Line (internal transceiver). |
| DMH | 46 | 72 | D9 | O | — | D- External Pull-up Control Output. |
| DMLN | 42 | 68 | E9 | O | — | D- External Pull-down Control Output. |
| DPH | 50 | 77 | A10 | O | — | D+ External Pull-up Control Output. |
| DPLN | 43 | 69 | E10 | O | — | D+ External Pull-down Control Output. |
| ENVREG | 57 | 86 | J7 | I | ST | Voltage Regulator Enable. |
| GCLK | 52 | 1 | B2 | O | — | Graphics Display Pixel Clock. |
| GD0 | 60 | 6 | D1 | O | — | Graphics Controller Data Output. |
| GD1 | 61 | 8 | E2 | O | — | |
| GD2 | 62 | 39 | L6 | O | — | |
| GD3 | 63 | 52 | K11 | O | — | |
| GD4 | 31 | 21 | H2 | O | — | |
| GD5 | 32 | 22 | J1 | O | — | |
| GD6 | 44 | 23 | J2 | O | — | |
| GD7 | 45 | 76 | A11 | O | — | |
| GD8 | 43 | 7 | E4 | O | — | |
| GD9 | 49 | 53 | J10 | O | — | |
| GD10 | 58 | 69 | E10 | O | — | |
| GD11 | 59 | 77 | A10 | O | — | |
| GD12 | 2 | 32 | K4 | O | — | |
| GD13 | 3 | 33 | L4 | O | — | |
| GD14 | 6 | 47 | L9 | O | — | |
| GD15 | 8 | 48 | K9 | O | — | |
| GEN | 51 | 91 | C5 | O | — | Graphics Display Enable Output. |
| GPWR | 53 | 27 | J3 | O | — | Graphics Display Power System Enable. |
| HSYNC | 64 | 97 | A3 | O | — | Graphics Display Horizontal Sync Pulse. |
| INT0 | 46 | 72 | D9 | I | ST | External Interrupt Input. |
| MCLR | 7 | 13 | F1 | I | ST | Master Clear (device Reset) Input. This line is brought low to cause a Reset. |
| OSCI | 39 | 63 | F9 | I | ANA | Main Oscillator Input Connection. |
| OSCO | 40 | 64 | F11 | O | ANA | Main Oscillator Output Connection. |

Legend: TTL = TTL input buffer
ANA = Analog level input/output

ST = Schmitt Trigger input buffer
I²C™ = I²C/SMBus input buffer

- Note**
- 1: The alternate EPMP pins are selected when the ALTPMP (CW3<12>) bit is programmed to '0'.
 - 2: The PMSC2 signal will replace the PMA15 signal on the 15-pin PMA when CSF<1:0> = 01 or 10.
 - 3: The PMCS1 signal will replace the PMA14 signal on the 14-pin PMA when CSF<1:0> = 10.
 - 4: The alternate VREF pins selected when the ALTVREF (CW1<5>) bit is programmed to '0'.

PIC24FJ256DA210 FAMILY

[查询PIC24FJ256DA106供应商](http://www.microchip.com)

TABLE 1-3: PIC24FJ256DA210 FAMILY PINOUT DESCRIPTIONS (CONTINUED)

| Function | Pin Number | | | I/O | Input Buffer | Description |
|----------|-----------------|--|---|-----|--------------|--|
| | 64-Pin TQFP/QFN | 100-Pin TQFP | 121-Pin BGA | | | |
| PGEC1 | 15 | 24 | K1 | I/O | ST | In-Circuit Debugger/Emulator/ICSP™ Programming Clock 1. |
| PGED1 | 16 | 25 | K2 | I/O | ST | In-Circuit Debugger/Emulator/ICSP Programming Data 1. |
| PGEC2 | 17 | 26 | L1 | I/O | ST | In-Circuit Debugger/Emulator/ICSP Programming Clock 2. |
| PGED2 | 18 | 27 | J3 | I/O | ST | In-Circuit Debugger/Emulator/ICSP Programming Data 2. |
| PGEC3 | 11 | 20 | H1 | I/O | ST | In-Circuit Debugger/Emulator/ICSP Programming Clock 3. |
| PGED3 | 12 | 21 | H2 | I/O | ST | In-Circuit Debugger/Emulator/ICSP Programming Data 3. |
| PMA0 | — | 44 | L8 | I/O | ST | Parallel Master Port Address bit 0 Input (Buffered Slave modes) and Output (Master modes). |
| PMA1 | — | 43 | K7 | I/O | ST | Parallel Master Port Address Bit 1 Input (Buffered Slave modes) and Output (Master modes). |
| PMA2 | — | 14 | F3 | O | — | Parallel Master Port Address bits<22:2>. |
| PMA3 | — | 12, 60 ⁽¹⁾ | F2, G11 ⁽¹⁾ | O | — | |
| PMA4 | — | 11, 59 ⁽¹⁾ | F4, G10 ⁽¹⁾ | O | — | |
| PMA5 | — | 10, 40 ⁽¹⁾ | E3, K6 ⁽¹⁾ | O | — | |
| PMA6 | — | 29 | K3 | O | — | |
| PMA7 | — | 28 | L2 | O | — | |
| PMA8 | — | 50 | L11 | O | — | |
| PMA9 | — | 49 | L10 | O | — | |
| PMA10 | — | 42 | L7 | O | — | |
| PMA11 | — | 41 | J7 | O | — | |
| PMA12 | — | 35 | J5 | O | — | |
| PMA13 | — | 34 | L5 | O | — | |
| PMA14 | — | 71 | C11 | O | — | |
| PMA15 | — | 70 | D11 | O | — | |
| PMA16 | — | 95 | C4 | O | — | |
| PMA17 | — | 92 | B5 | O | — | |
| PMA18 | — | 40, 10 ⁽¹⁾ | K6, E3 ⁽¹⁾ | O | — | |
| PMA19 | — | 19 | G2 | O | — | |
| PMA20 | — | 59, 11 ⁽¹⁾ | G10, F4 ⁽¹⁾ | O | — | |
| PMA21 | — | 60, 12 ⁽¹⁾ | G11, F2 ⁽¹⁾ | O | — | |
| PMA22 | — | 66, 9 ⁽¹⁾ | E11, E1 ⁽¹⁾ | O | — | |
| PMACK1 | — | 77 | A10 | I | ST/TTL | Parallel Master Port Acknowledge Input 1. |
| PMACK2 | — | 69 | E10 | I | ST/TTL | Parallel Master Port Acknowledge Input 2. |
| PMALL | — | 44 | L8 | O | — | Parallel Master Port Lower Address Latch Strobe. |
| PMALH | — | 43 | K7 | O | — | Parallel Master Port Higher Address Latch Strobe. |
| PMALU | — | 14 | F3 | O | — | Parallel Master Port Upper Address Latch Strobe. |
| PMBE0 | — | 78 | B9 | O | — | Parallel Master Port Byte Enable Strobe 0. |
| PMBE1 | — | 67 | E8 | O | — | Parallel Master Port Byte Enable Strobe 1. |
| PMCS1 | — | 71 ⁽³⁾ , 18 | C11 ⁽³⁾ , G1 | I/O | ST/TTL | Parallel Master Port Chip Select Strobe 1. |
| PMCS2 | — | 70 ⁽²⁾ , 9, 66 ⁽¹⁾ | D11 ⁽²⁾ , E1, E11 ⁽¹⁾ | O | — | Parallel Master Port Chip Select Strobe 2. |

Legend: TTL = TTL input buffer ST = Schmitt Trigger input buffer
 ANA = Analog level input/output I²C™ = I²C/SMBus input buffer

- Note** 1: The alternate EPMP pins are selected when the ALTPMP (CW3<12>) bit is programmed to '0'.
 2: The PMCS2 signal will replace the PMA15 signal on the 15-pin PMA when CSF<1:0> = 01 or 10.
 3: The PMCS1 signal will replace the PMA14 signal on the 14-pin PMA when CSF<1:0> = 10.
 4: The alternate VREF pins selected when the ALTVREF (CW1<5>) bit is programmed to '0'.

PIC24FJ256DA210 FAMILY

[查询PIC24FJ256DA106供应商](#)

TABLE 1-3: PIC24FJ256DA210 FAMILY PINOUT DESCRIPTIONS (CONTINUED)

| Function | Pin Number | | | I/O | Input Buffer | Description |
|----------|-----------------|--------------|-------------|-----|--------------|---------------------------------------|
| | 64-Pin TQFP/QFN | 100-Pin TQFP | 121-Pin BGA | | | |
| PMD0 | — | 93 | A4 | I/O | ST/TTL | Parallel Master Port Data bits<15:0>. |
| PMD1 | — | 94 | B4 | I/O | ST/TTL | |
| PMD2 | — | 98 | B3 | I/O | ST/TTL | |
| PMD3 | — | 99 | A2 | I/O | ST/TTL | |
| PMD4 | — | 100 | A1 | I/O | ST/TTL | |
| PMD5 | — | 3 | D3 | I/O | ST/TTL | |
| PMD6 | — | 4 | C1 | I/O | ST/TTL | |
| PMD7 | — | 5 | D2 | I/O | ST/TTL | |
| PMD8 | — | 90 | A5 | I/O | ST/TTL | |
| PMD9 | — | 89 | E6 | I/O | ST/TTL | |
| PMD10 | — | 88 | A6 | I/O | ST/TTL | |
| PMD11 | — | 87 | B6 | I/O | ST/TTL | |
| PMD12 | — | 79 | A9 | I/O | ST/TTL | |
| PMD13 | — | 80 | D8 | I/O | ST/TTL | |
| PMD14 | — | 83 | D7 | I/O | ST/TTL | |
| PMD15 | — | 84 | C7 | I/O | ST/TTL | |
| PMRD | — | 82 | B8 | I/O | ST/TTL | Parallel Master Port Read Strobe. |
| PMWR | — | 81 | C8 | I/O | ST/TTL | Parallel Master Port Write Strobe. |
| RA0 | — | 17 | G3 | I/O | ST | PORTA Digital I/O. |
| RA1 | — | 38 | J6 | I/O | ST | |
| RA2 | — | 58 | H11 | I/O | ST | |
| RA3 | — | 59 | G10 | I/O | ST | |
| RA4 | — | 60 | G11 | I/O | ST | |
| RA5 | — | 61 | G9 | I/O | ST | |
| RA6 | — | 91 | C5 | I/O | ST | |
| RA7 | — | 92 | B5 | I/O | ST | |
| RA9 | — | 28 | L2 | I/O | ST | |
| RA10 | — | 29 | K3 | I/O | ST | |
| RA14 | — | 66 | E11 | I/O | ST | |
| RA15 | — | 67 | E8 | I/O | ST | |

Legend: TTL = TTL input buffer ST = Schmitt Trigger input buffer
ANA = Analog level input/output I²C™ = I²C/SMBus input buffer

- Note**
- 1: The alternate EPMP pins are selected when the ALTPMP (CW3<12>) bit is programmed to '0'.
 - 2: The PMSC2 signal will replace the PMA15 signal on the 15-pin PMA when CSF<1:0> = 01 or 10.
 - 3: The PMCS1 signal will replace the PMA14 signal on the 14-pin PMA when CSF<1:0> = 10.
 - 4: The alternate VREF pins selected when the ALTVREF (CW1<5>) bit is programmed to '0'.

PIC24FJ256DA210 FAMILY

[查询PIC24FJ256DA106供应商](#)

TABLE 1-3: PIC24FJ256DA210 FAMILY PINOUT DESCRIPTIONS (CONTINUED)

| Function | Pin Number | | | I/O | Input Buffer | Description |
|----------|-----------------|--------------|-------------|-----|--------------|--|
| | 64-Pin TQFP/QFN | 100-Pin TQFP | 121-Pin BGA | | | |
| RB0 | 16 | 25 | K2 | I/O | ST | PORTB Digital I/O. |
| RB1 | 15 | 24 | K1 | I/O | ST | |
| RB2 | 14 | 23 | J2 | I/O | ST | |
| RB3 | 13 | 22 | J1 | I/O | ST | |
| RB4 | 12 | 21 | H2 | I/O | ST | |
| RB5 | 11 | 20 | H1 | I/O | ST | |
| RB6 | 17 | 26 | L1 | I/O | ST | |
| RB7 | 18 | 27 | J3 | I/O | ST | |
| RB8 | 21 | 32 | K4 | I/O | ST | |
| RB9 | 22 | 33 | L4 | I/O | ST | |
| RB10 | 23 | 34 | L5 | I/O | ST | |
| RB11 | 24 | 35 | J5 | I/O | ST | |
| RB12 | 27 | 41 | J7 | I/O | ST | |
| RB13 | 28 | 42 | L7 | I/O | ST | |
| RB14 | 29 | 43 | K7 | I/O | ST | |
| RB15 | 30 | 44 | L8 | I/O | ST | |
| RC1 | — | 6 | D1 | I/O | ST | PORTC Digital I/O. |
| RC2 | — | 7 | E4 | I/O | ST | |
| RC3 | — | 8 | E2 | I/O | ST | |
| RC4 | — | 9 | E1 | I/O | ST | |
| RC12 | 39 | 63 | F9 | I/O | ST | |
| RC13 | 47 | 73 | C10 | I/O | ST | |
| RC14 | 48 | 74 | B11 | I/O | ST | |
| RC15 | 40 | 64 | F11 | I/O | ST | |
| RCV | 18 | 27 | J3 | I | ST | USB Receive Input (from external transceiver). |

Legend: TTL = TTL input buffer ST = Schmitt Trigger input buffer
ANA = Analog level input/output I²C™ = I²C/SMBus input buffer

- Note**
- 1:** The alternate EPMP pins are selected when the ALTPMP (CW3<12>) bit is programmed to '0'.
 - 2:** The PMSC2 signal will replace the PMA15 signal on the 15-pin PMA when CSF<1:0> = 01 or 10.
 - 3:** The PMCS1 signal will replace the PMA14 signal on the 14-pin PMA when CSF<1:0> = 10.
 - 4:** The alternate VREF pins selected when the ALTVREF (CW1<5>) bit is programmed to '0'.

PIC24FJ256DA210 FAMILY

[查询PIC24FJ256DA106供应商](#)

TABLE 1-3: PIC24FJ256DA210 FAMILY PINOUT DESCRIPTIONS (CONTINUED)

| Function | Pin Number | | | I/O | Input Buffer | Description |
|----------|-----------------|--------------|-------------|-----|--------------|-------------------------|
| | 64-Pin TQFP/QFN | 100-Pin TQFP | 121-Pin BGA | | | |
| RD0 | 46 | 72 | D9 | I/O | ST | PORTD Digital I/O. |
| RD1 | 49 | 76 | A11 | I/O | ST | |
| RD2 | 50 | 77 | A10 | I/O | ST | |
| RD3 | 51 | 78 | B9 | I/O | ST | |
| RD4 | 52 | 81 | C8 | I/O | ST | |
| RD5 | 53 | 82 | B8 | I/O | ST | |
| RD6 | 54 | 83 | D7 | I/O | ST | |
| RD7 | 55 | 84 | C7 | I/O | ST | |
| RD8 | 42 | 68 | E9 | I/O | ST | |
| RD9 | 43 | 69 | E10 | I/O | ST | |
| RD10 | 44 | 70 | D11 | I/O | ST | |
| RD11 | 45 | 71 | C11 | I/O | ST | |
| RD12 | — | 79 | A9 | I/O | ST | |
| RD13 | — | 80 | D8 | I/O | ST | |
| RD14 | — | 47 | L9 | I/O | ST | |
| RD15 | — | 48 | K9 | I/O | ST | |
| RE0 | 60 | 93 | A4 | I/O | ST | PORTE Digital I/O. |
| RE1 | 61 | 94 | B4 | I/O | ST | |
| RE2 | 62 | 98 | B3 | I/O | ST | |
| RE3 | 63 | 99 | A2 | I/O | ST | |
| RE4 | 64 | 100 | A1 | I/O | ST | |
| RE5 | 1 | 3 | D3 | I/O | ST | |
| RE6 | 2 | 4 | C1 | I/O | ST | |
| RE7 | 3 | 5 | D2 | I/O | ST | |
| RE8 | — | 18 | G1 | I/O | ST | |
| RE9 | — | 19 | G2 | I/O | ST | |
| REFO | 30 | 44 | L8 | O | — | Reference Clock Output. |
| RF0 | 58 | 87 | B6 | I/O | ST | PORTF Digital I/O. |
| RF1 | 59 | 88 | A6 | I/O | ST | |
| RF2 | — | 52 | K11 | I/O | ST | |
| RF3 | 33 | 51 | K10 | I/O | ST | |
| RF4 | 31 | 49 | L10 | I/O | ST | |
| RF5 | 32 | 50 | L11 | I/O | ST | |
| RF7 | 34 | 54 | H8 | I/O | ST | |
| RF8 | — | 53 | J10 | I/O | ST | |
| RF12 | — | 40 | K6 | I/O | ST | |
| RF13 | — | 39 | L6 | I/O | ST | |

Legend: TTL = TTL input buffer
 ANA = Analog level input/output
 ST = Schmitt Trigger input buffer
 I²C™ = I²C/SMBus input buffer

- Note**
- 1: The alternate EPMP pins are selected when the ALTPMP (CW3<12>) bit is programmed to '0'.
 - 2: The PMSC2 signal will replace the PMA15 signal on the 15-pin PMA when CSF<1:0> = 01 or 10.
 - 3: The PMCS1 signal will replace the PMA14 signal on the 14-pin PMA when CSF<1:0> = 10.
 - 4: The alternate VREF pins selected when the ALTVREF (CW1<5>) bit is programmed to '0'.

PIC24FJ256DA210 FAMILY

[查询PIC24FJ256DA106供应商](#)

TABLE 1-3: PIC24FJ256DA210 FAMILY PINOUT DESCRIPTIONS (CONTINUED)

| Function | Pin Number | | | I/O | Input Buffer | Description | |
|----------|-----------------|--------------|-------------|-----|--------------|--------------------|--|
| | 64-Pin TQFP/QFN | 100-Pin TQFP | 121-Pin BGA | | | | |
| RG0 | — | 90 | A5 | I/O | ST | PORTG Digital I/O. | |
| RG1 | — | 89 | E6 | I/O | ST | | |
| RG2 | 37 | 57 | H10 | I/O | ST | | |
| RG3 | 36 | 56 | J11 | I/O | ST | | |
| RG6 | 4 | 10 | E3 | I/O | ST | | |
| RG7 | 5 | 11 | F4 | I/O | ST | | |
| RG8 | 6 | 12 | F2 | I/O | ST | | |
| RG9 | 8 | 14 | F3 | I/O | ST | | |
| RG12 | — | 96 | C3 | I/O | ST | | |
| RG13 | — | 97 | A3 | I/O | ST | | |
| RG14 | — | 95 | C4 | I/O | ST | | |
| RG15 | — | 1 | B2 | I/O | ST | | |
| RP0 | 16 | 25 | K2 | I/O | ST | | Remappable Peripheral (input or output). |
| RP1 | 15 | 24 | K1 | I/O | ST | | |
| RP2 | 42 | 68 | E9 | I/O | ST | | |
| RP3 | 44 | 70 | D11 | I/O | ST | | |
| RP4 | 43 | 69 | E10 | I/O | ST | | |
| RP5 | — | 48 | K9 | I/O | ST | | |
| RP6 | 17 | 26 | L1 | I/O | ST | | |
| RP7 | 18 | 27 | J3 | I/O | ST | | |
| RP8 | 21 | 32 | K4 | I/O | ST | | |
| RP9 | 22 | 33 | L4 | I/O | ST | | |
| RP10 | 31 | 49 | L10 | I/O | ST | | |
| RP11 | 46 | 72 | D9 | I/O | ST | | |
| RP12 | 45 | 71 | C11 | I/O | ST | | |
| RP13 | 14 | 23 | J2 | I/O | ST | | |
| RP14 | 29 | 43 | K7 | I/O | ST | | |
| RP15 | — | 53 | J10 | I/O | ST | | |
| RP16 | 33 | 51 | K10 | I/O | ST | | |
| RP17 | 32 | 50 | L11 | I/O | ST | | |
| RP18 | 11 | 20 | H1 | I/O | ST | | |
| RP19 | 6 | 12 | F2 | I/O | ST | | |

Legend: TTL = TTL input buffer
ANA = Analog level input/output
ST = Schmitt Trigger input buffer
I²C™ = I²C/SMBus input buffer

- Note**
- 1: The alternate EPMP pins are selected when the $\overline{\text{ALTPMP}}$ (CW3<12>) bit is programmed to '0'.
 - 2: The PMSC2 signal will replace the PMA15 signal on the 15-pin PMA when CSF<1:0> = 01 or 10.
 - 3: The PMCS1 signal will replace the PMA14 signal on the 14-pin PMA when CSF<1:0> = 10.
 - 4: The alternate VREF pins selected when the $\overline{\text{ALTVREF}}$ (CW1<5>) bit is programmed to '0'.

PIC24FJ256DA210 FAMILY

[查询PIC24FJ256DA106供应商](#)

TABLE 1-3: PIC24FJ256DA210 FAMILY PINOUT DESCRIPTIONS (CONTINUED)

| Function | Pin Number | | | I/O | Input Buffer | Description |
|----------|-----------------|--------------|-------------|-----|-------------------|---|
| | 64-Pin TQFP/QFN | 100-Pin TQFP | 121-Pin BGA | | | |
| RP20 | 53 | 82 | B8 | I/O | ST | Remappable Peripheral (input or output). |
| RP21 | 4 | 10 | E3 | I/O | ST | |
| RP22 | 51 | 78 | B9 | I/O | ST | |
| RP23 | 50 | 77 | A10 | I/O | ST | |
| RP24 | 49 | 76 | A11 | I/O | ST | |
| RP25 | 52 | 81 | C8 | I/O | ST | |
| RP26 | 5 | 11 | F4 | I/O | ST | |
| RP27 | 8 | 14 | F3 | I/O | ST | |
| RP28 | 12 | 21 | H2 | I/O | ST | |
| RP29 | 30 | 44 | L8 | I/O | ST | |
| RP30 | — | 52 | K11 | I/O | ST | |
| RP31 | — | 39 | L6 | I/O | ST | |
| RPI32 | — | 40 | K6 | I | ST | |
| RPI33 | — | 18 | G1 | I | ST | |
| RPI34 | — | 19 | G2 | I | ST | |
| RPI35 | — | 67 | E8 | I | ST | |
| RPI36 | — | 66 | E11 | I | ST | |
| RPI37 | 48 | 74 | B11 | I | ST | |
| RPI38 | — | 6 | D1 | I | ST | |
| RPI39 | — | 7 | E4 | I | ST | |
| RPI40 | — | 8 | E2 | I | ST | |
| RPI41 | — | 9 | E1 | I | ST | |
| RPI42 | — | 79 | A9 | I | ST | |
| RPI43 | — | 47 | L9 | I | ST | |
| RTCC | 42 | 68 | E9 | O | — | Real-Time Clock Alarm/Seconds Pulse Output. |
| SCL1 | 44 | 66 | E11 | I/O | I ² C™ | I2C1 Synchronous Serial Clock Input/Output. |
| SCL2 | 32 | 58 | H11 | I/O | I ² C | I2C2 Synchronous Serial Clock Input/Output. |
| SCL3 | 2 | 4 | C1 | I/O | I ² C | I2C3 Synchronous Serial Clock Input/Output. |
| SCLKI | 48 | 74 | B11 | O | ANA | Secondary Clock Input. |
| SDA1 | 43 | 67 | E8 | I/O | I ² C | I2C1 Data Input/Output. |
| SDA2 | 31 | 59 | G10 | I/O | I ² C | I2C2 Data Input/Output. |
| SDA3 | 3 | 5 | D2 | I/O | I ² C | I2C3 Data Input/Output. |
| SESSEND | 55 | 84 | C7 | I | ST | USB VBus Boost Generator, Comparator Input 3. |
| SESSVLD | 59 | 88 | A6 | I | ST | USB VBus Boost Generator, Comparator Input 2. |
| SOSCI | 47 | 73 | C10 | I | ANA | Secondary Oscillator/Timer1 Clock Input. |
| SOSCO | 48 | 74 | B11 | O | ANA | Secondary Oscillator/Timer1 Clock Output. |
| T1CK | 48 | 74 | B11 | I | ST | Timer1 Clock. |

Legend: TTL = TTL input buffer
ANA = Analog level input/output

ST = Schmitt Trigger input buffer
I²C™ = I²C/SMBus input buffer

- Note**
- 1: The alternate EPMP pins are selected when the $\overline{\text{ALTPMP}}$ (CW3<12>) bit is programmed to '0'.
 - 2: The PMSC2 signal will replace the PMA15 signal on the 15-pin PMA when CSF<1:0> = 01 or 10.
 - 3: The PMCS1 signal will replace the PMA14 signal on the 14-pin PMA when CSF<1:0> = 10.
 - 4: The alternate VREF pins selected when the $\overline{\text{ALTVREF}}$ (CW1<5>) bit is programmed to '0'.

PIC24FJ256DA210 FAMILY

[查询PIC24FJ256DA106供应商](#)

NOTES:

PIC24FJ256DA210 FAMILY

[查询PIC24FJ256DA106供应商](#)

2.0 GUIDELINES FOR GETTING STARTED WITH 16-BIT MICROCONTROLLERS

2.1 Basic Connection Requirements

Getting started with the PIC24FJ256DA210 family of 16-bit microcontrollers requires attention to a minimal set of device pin connections before proceeding with development.

The following pins must always be connected:

- All VDD and VSS pins (see **Section 2.2 “Power Supply Pins”**)
- All AVDD and AVSS pins, regardless of whether or not the analog device features are used (see **Section 2.2 “Power Supply Pins”**)
- MCLR pin (see **Section 2.3 “Master Clear (MCLR) Pin”**)
- ENVREG/DISVREG and VCAP/VDDCORE pins (PIC24FJ devices only) (see **Section 2.4 “Voltage Regulator Pins (ENVREG/DISVREG and VCAP/VDDCORE)”**)

These pins must also be connected if they are being used in the end application:

- PGECx/PGEDx pins used for In-Circuit Serial Programming™ (ICSP™) and debugging purposes (see **Section 2.5 “ICSP Pins”**)
- OSCI and OSCO pins when an external oscillator source is used (see **Section 2.6 “External Oscillator Pins”**)

Additionally, the following pins may be required:

- VREF+/VREF- pins used when external voltage reference for analog modules is implemented

Note: The AVDD and AVSS pins must always be connected, regardless of whether any of the analog modules are being used.

The minimum mandatory connections are shown in Figure 2-1.

FIGURE 2-1: RECOMMENDED MINIMUM CONNECTIONS

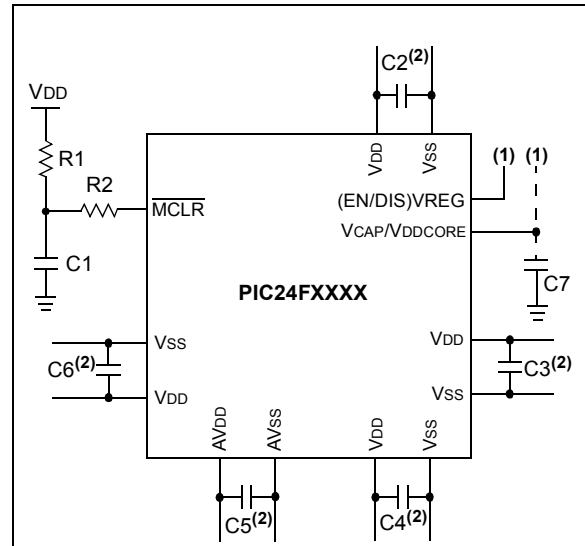

Key (all values are recommendations):

C1 through C6: 0.1 μ F, 20V ceramic

C7: 10 μ F, 6.3V or greater, tantalum or ceramic

R1: 10 k Ω

R2: 100 Ω to 470 Ω

Note 1: See **Section 2.4 “Voltage Regulator Pins (ENVREG/DISVREG and VCAP/VDDCORE)”** for explanation of ENVREG/DISVREG pin connections.

Note 2: The example shown is for a PIC24F device with five VDD/VSS and AVDD/AVSS pairs. Other devices may have more or less pairs; adjust the number of decoupling capacitors appropriately.

PIC24FJ256DA210 FAMILY

[查询PIC24FJ256DA106供应商](#)

2.2 Power Supply Pins

2.2.1 DECOUPLING CAPACITORS

The use of decoupling capacitors on every pair of power supply pins, such as VDD, VSS, AVDD and AVSS is required.

Consider the following criteria when using decoupling capacitors:

- **Value and type of capacitor:** A 0.1 μF (100 nF), 10-20V capacitor is recommended. The capacitor should be a low-ESR device with a resonance frequency in the range of 200 MHz and higher. Ceramic capacitors are recommended.
- **Placement on the printed circuit board:** The decoupling capacitors should be placed as close to the pins as possible. It is recommended to place the capacitors on the same side of the board as the device. If space is constricted, the capacitor can be placed on another layer on the PCB using a via; however, ensure that the trace length from the pin to the capacitor is no greater than 0.25 inch (6 mm).
- **Handling high-frequency noise:** If the board is experiencing high-frequency noise (upward of tens of MHz), add a second ceramic type capacitor in parallel to the above described decoupling capacitor. The value of the second capacitor can be in the range of 0.01 μF to 0.001 μF . Place this second capacitor next to each primary decoupling capacitor. In high-speed circuit designs, consider implementing a decade pair of capacitances as close to the power and ground pins as possible (e.g., 0.1 μF in parallel with 0.001 μF).
- **Maximizing performance:** On the board layout from the power supply circuit, run the power and return traces to the decoupling capacitors first, and then to the device pins. This ensures that the decoupling capacitors are first in the power chain. Equally important is to keep the trace length between the capacitor and the power pins to a minimum, thereby reducing PCB trace inductance.

2.2.2 TANK CAPACITORS

On boards with power traces running longer than six inches in length, it is suggested to use a tank capacitor for integrated circuits including microcontrollers to supply a local power source. The value of the tank capacitor should be determined based on the trace resistance that connects the power supply source to the device, and the maximum current drawn by the device in the application. In other words, select the tank capacitor so that it meets the acceptable voltage sag at the device. Typical values range from 4.7 μF to 47 μF .

2.3 Master Clear (MCLR) Pin

The $\overline{\text{MCLR}}$ pin provides two specific device functions: device Reset, and device programming and debugging. If programming and debugging are not required in the end application, a direct connection to VDD may be all that is required. The addition of other components, to help increase the application's resistance to spurious Resets from voltage sags, may be beneficial. A typical configuration is shown in Figure 2-1. Other circuit designs may be implemented, depending on the application's requirements.

During programming and debugging, the resistance and capacitance that can be added to the pin must be considered. Device programmers and debuggers drive the MCLR pin. Consequently, specific voltage levels (V_{IH} and V_{IL}) and fast signal transitions must not be adversely affected. Therefore, specific values of R1 and C1 will need to be adjusted based on the application and PCB requirements. For example, it is recommended that the capacitor, C1, be isolated from the $\overline{\text{MCLR}}$ pin during programming and debugging operations by using a jumper (Figure 2-2). The jumper is replaced for normal run-time operations.

Any components associated with the $\overline{\text{MCLR}}$ pin should be placed within 0.25 inch (6 mm) of the pin.

FIGURE 2-2: EXAMPLE OF MCLR PIN CONNECTIONS

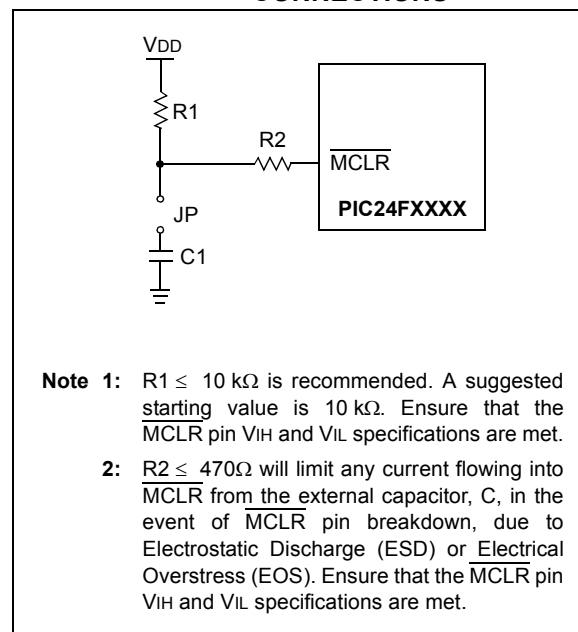

PIC24FJ256DA210 FAMILY

[查询PIC24FJ256DA106供应商](#)

2.4 Voltage Regulator Pins (ENVREG/DISVREG and VCAP/VDDCORE)

Note: This section applies only to PIC24FJ devices with an on-chip voltage regulator.

The on-chip voltage regulator enable/disable pin (ENVREG or DISVREG, depending on the device family) must always be connected directly to either a supply voltage or to ground. The particular connection is determined by whether or not the regulator is to be used:

- For ENVREG, tie to VDD to enable the regulator, or to ground to disable the regulator
- For DISVREG, tie to ground to enable the regulator or to VDD to disable the regulator

Refer to **Section 27.2 “On-Chip Voltage Regulator”** for details on connecting and using the on-chip regulator.

When the regulator is enabled, a low-ESR (<5 Ω) capacitor is required on the VCAP/VDDCORE pin to stabilize the voltage regulator output voltage. The VCAP/VDDCORE pin must not be connected to VDD, and must use a capacitor of 10 μ F connected to ground. The type can be ceramic or tantalum. A suitable example is the Murata GRM21BF50J106ZE01 (10 μ F, 6.3V) or equivalent. Designers may use Figure 2-3 to evaluate ESR equivalence of candidate devices.

The placement of this capacitor should be close to VCAP/VDDCORE. It is recommended that the trace length not exceed 0.25 inch (6 mm). Refer to **Section 30.0 “Electrical Characteristics”** for additional information.

When the regulator is disabled, the VCAP/VDDCORE pin must be tied to a voltage supply at the VDDCORE level. Refer to **Section 30.0 “Electrical Characteristics”** for information on VDD and VDDCORE.

FIGURE 2-3: FREQUENCY vs. ESR PERFORMANCE FOR SUGGESTED VCAP

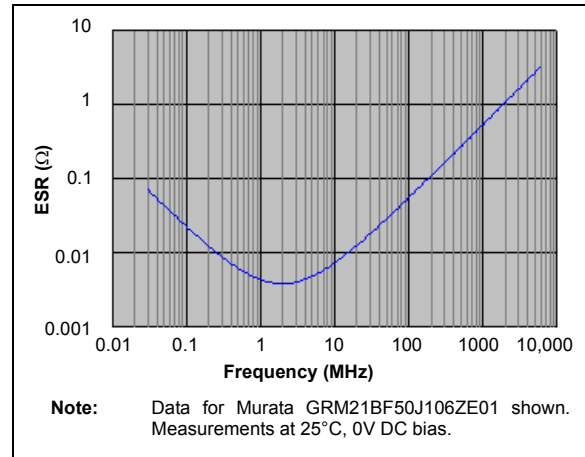

2.5 ICSP Pins

The PGECx and PGEDx pins are used for In-Circuit Serial Programming (ICSP) and debugging purposes. It is recommended to keep the trace length between the ICSP connector and the ICSP pins on the device as short as possible. If the ICSP connector is expected to experience an ESD event, a series resistor is recommended, with the value in the range of a few tens of ohms, not to exceed 100 Ω .

Pull-up resistors, series diodes and capacitors on the PGECx and PGEDx pins are not recommended as they will interfere with the programmer/debugger communications to the device. If such discrete components are an application requirement, they should be removed from the circuit during programming and debugging. Alternatively, refer to the AC/DC characteristics and timing requirements information in the respective device Flash programming specification for information on capacitive loading limits and pin input voltage high (VIH) and input low (VIL) requirements.

For device emulation, ensure that the “Communication Channel Select” (i.e., PGECx/PGEDx pins) programmed into the device matches the physical connections for the ICSP to the Microchip debugger/emulator tool.

For more information on available Microchip development tools connection requirements, refer to **Section 28.0 “Development Support”**.

PIC24FJ256DA210 FAMILY

[查询PIC24FJ256DA106供应商](#)

2.6 External Oscillator Pins

Many microcontrollers have options for at least two oscillators: a high-frequency primary oscillator and a low-frequency secondary oscillator (refer to **Section 8.0 “Oscillator Configuration”** for details).

The oscillator circuit should be placed on the same side of the board as the device. Place the oscillator circuit close to the respective oscillator pins with no more than 0.5 inch (12 mm) between the circuit components and the pins. The load capacitors should be placed next to the oscillator itself, on the same side of the board.

Use a grounded copper pour around the oscillator circuit to isolate it from surrounding circuits. The grounded copper pour should be routed directly to the MCU ground. Do not run any signal traces or power traces inside the ground pour. Also, if using a two-sided board, avoid any traces on the other side of the board where the crystal is placed.

Layout suggestions are shown in Figure 2-4. In-line packages may be handled with a single-sided layout that completely encompasses the oscillator pins. With fine-pitch packages, it is not always possible to completely surround the pins and components. A suitable solution is to tie the broken guard sections to a mirrored ground layer. In all cases, the guard trace(s) must be returned to ground.

In planning the application’s routing and I/O assignments, ensure that adjacent port pins and other signals in close proximity to the oscillator are benign (i.e., free of high frequencies, short rise and fall times and other similar noise).

For additional information and design guidance on oscillator circuits, please refer to these Microchip Application Notes, available at the corporate web site (www.microchip.com):

- AN826, “Crystal Oscillator Basics and Crystal Selection for rPIC™ and PICmicro® Devices”
- AN849, “Basic PICmicro® Oscillator Design”
- AN943, “Practical PICmicro® Oscillator Analysis and Design”
- AN949, “Making Your Oscillator Work”

FIGURE 2-4: SUGGESTED PLACEMENT OF THE OSCILLATOR CIRCUIT

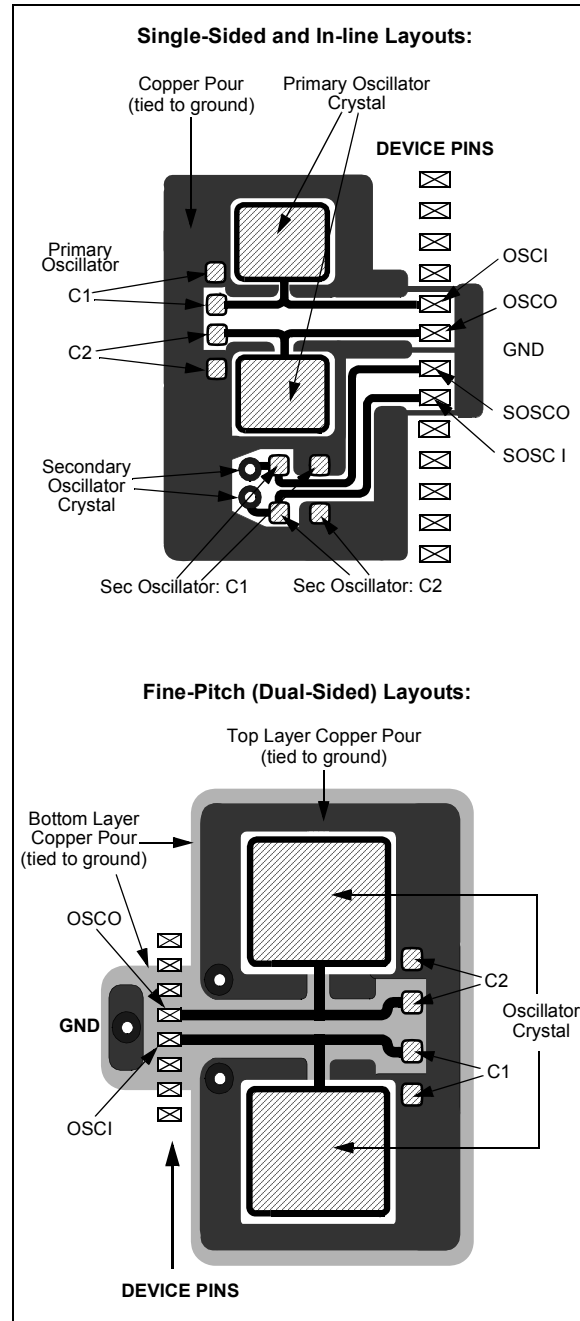

PIC24FJ256DA210 FAMILY

[查询PIC24FJ256DA106供应商](#)

2.7 Configuration of Analog and Digital Pins During ICSP Operations

If an ICSP compliant emulator is selected as a debugger, it automatically initializes all of the A/D input pins (ANx) as “digital” pins. Depending on the particular device, this is done by setting all bits in the ADnPCFG register(s), or clearing all bit in the ANSx registers.

All PIC24F devices will have either one or more ADnPCFG registers or several ANSx registers (one for each port); no device will have both. Refer to (**Section 23.0 “10-Bit High-Speed A/D Converter”**) for more specific information.

The bits in these registers that correspond to the A/D pins that initialized the emulator must not be changed by the user application firmware; otherwise, communication errors will result between the debugger and the device.

If your application needs to use certain A/D pins as analog input pins during the debug session, the user application must modify the appropriate bits during initialization of the ADC module, as follows:

- For devices with an ADnPCFG register, clear the bits corresponding to the pin(s) to be configured as analog. Do not change any other bits, particularly those corresponding to the PGECx/PGEDx pair, at any time.
- For devices with ANSx registers, set the bits corresponding to the pin(s) to be configured as analog. Do not change any other bits, particularly those corresponding to the PGECx/PGEDx pair, at any time.

When a Microchip debugger/emulator is used as a programmer, the user application firmware must correctly configure the ADnPCFG or ANSx registers. Automatic initialization of this register is only done during debugger operation. Failure to correctly configure the register(s) will result in all A/D pins being recognized as analog input pins, resulting in the port value being read as a logic '0', which may affect user application functionality.

2.8 Unused I/Os

Unused I/O pins should be configured as outputs and driven to a logic low state. Alternatively, connect a 1 k Ω to 10 k Ω resistor to Vss on unused pins and drive the output to logic low.

PIC24FJ256DA210 FAMILY

[查询PIC24FJ256DA106供应商](#)

NOTES:

PIC24FJ256DA210 FAMILY

[查询PIC24FJ256DA106供应商](#)

3.0 CPU

Note: This data sheet summarizes the features of this group of PIC24F devices. It is not intended to be a comprehensive reference source. For more information, refer to the “PIC24F Family Reference Manual”, **Section 44. “CPU with Extended Data Space (EDS)”** (DS39732). The information in this data sheet supersedes the information in the FRM.

The PIC24F CPU has a 16-bit (data) modified Harvard architecture with an enhanced instruction set and a 24-bit instruction word with a variable length opcode field. The Program Counter (PC) is 23 bits wide and addresses up to 4M instructions of user program memory space. A single-cycle instruction prefetch mechanism is used to help maintain throughput and provides predictable execution. All instructions execute in a single cycle, with the exception of instructions that change the program flow, the double-word move (MOV.D) instruction and the table instructions. Overhead-free program loop constructs are supported using the REPEAT instructions, which are interruptible at any point.

PIC24F devices have sixteen, 16-bit working registers in the programmer’s model. Each of the working registers can act as a data, address or address offset register. The 16th working register (W15) operates as a Software Stack Pointer for interrupts and calls.

The lower 32 Kbytes of the data space can be accessed linearly. The upper 32 Kbytes of the data space are referred to as extended data space to which the extended data RAM, EPMP memory space or program memory can be mapped.

The Instruction Set Architecture (ISA) has been significantly enhanced beyond that of the PIC18, but maintains an acceptable level of backward compatibility. All PIC18 instructions and addressing modes are supported, either directly, or through simple macros. Many of the ISA enhancements have been driven by compiler efficiency needs.

The core supports Inherent (no operand), Relative, Literal, Memory Direct Addressing modes along with three groups of addressing modes. All modes support Register Direct and various Register Indirect modes. Each group offers up to seven addressing modes. Instructions are associated with predefined addressing modes depending upon their functional requirements.

For most instructions, the core is capable of executing a data (or program data) memory read, a working register (data) read, a data memory write and a program (instruction) memory read per instruction cycle. As a result, three parameter instructions can be supported, allowing trinary operations (that is, $A + B = C$) to be executed in a single cycle.

A high-speed, 17-bit x 17-bit multiplier has been included to significantly enhance the core arithmetic capability and throughput. The multiplier supports Signed, Unsigned and Mixed mode, 16-bit x 16-bit or 8-bit x 8-bit, integer multiplication. All multiply instructions execute in a single cycle.

The 16-bit ALU has been enhanced with integer divide assist hardware that supports an iterative non-restoring divide algorithm. It operates in conjunction with the REPEAT instruction looping mechanism and a selection of iterative divide instructions to support 32-bit (or 16-bit), divided by 16-bit, integer signed and unsigned division. All divide operations require 19 cycles to complete but are interruptible at any cycle boundary.

The PIC24F has a vectored exception scheme with up to 8 sources of non-maskable traps and up to 118 interrupt sources. Each interrupt source can be assigned to one of seven priority levels.

A block diagram of the CPU is shown in Figure 3-1.

3.1 Programmer’s Model

The programmer’s model for the PIC24F is shown in Figure 3-2. All registers in the programmer’s model are memory mapped and can be manipulated directly by instructions. A description of each register is provided in Table 3-1. All registers associated with the programmer’s model are memory mapped.

PIC24FJ256DA210 FAMILY

[查询PIC24FJ256DA106供应商](#)

FIGURE 3-1: PIC24F CPU CORE BLOCK DIAGRAM

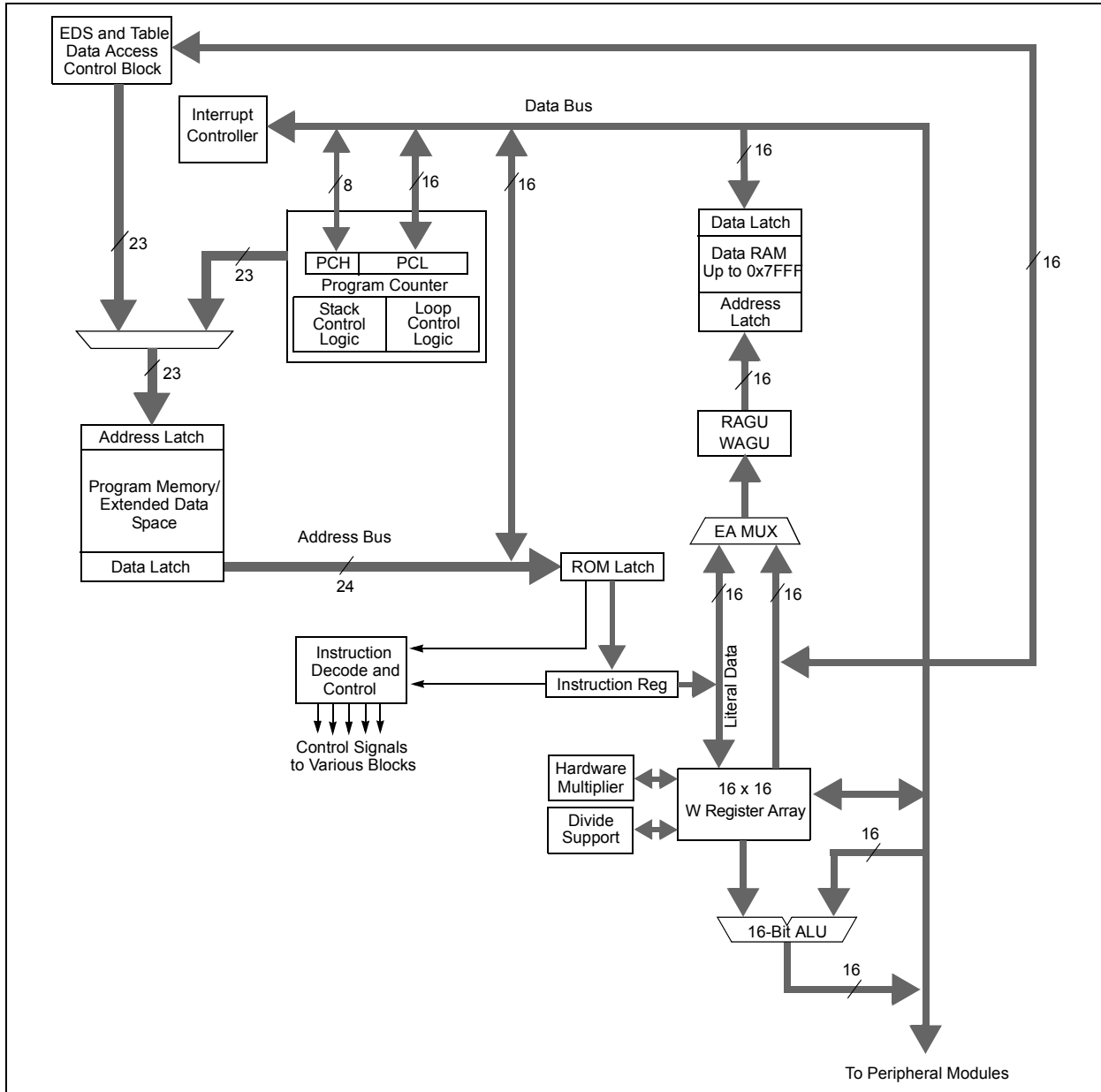

TABLE 3-1: CPU CORE REGISTERS

| Register(s) Name | Description |
|------------------|------------------------------------|
| W0 through W15 | Working Register Array |
| PC | 23-Bit Program Counter |
| SR | ALU STATUS Register |
| SPLIM | Stack Pointer Limit Value Register |
| TBLPAG | Table Memory Page Address Register |
| RCOUNT | Repeat Loop Counter Register |
| CORCON | CPU Control Register |
| DISICNT | Disable Interrupt Count Register |
| DSRPAG | Data Space Read Page Register |
| DSWPAG | Data Space Write Page Register |

PIC24FJ256DA210 FAMILY

查询PIC24FJ256DA106供应商

FIGURE 3-2. PROGRAMMER'S MODEL

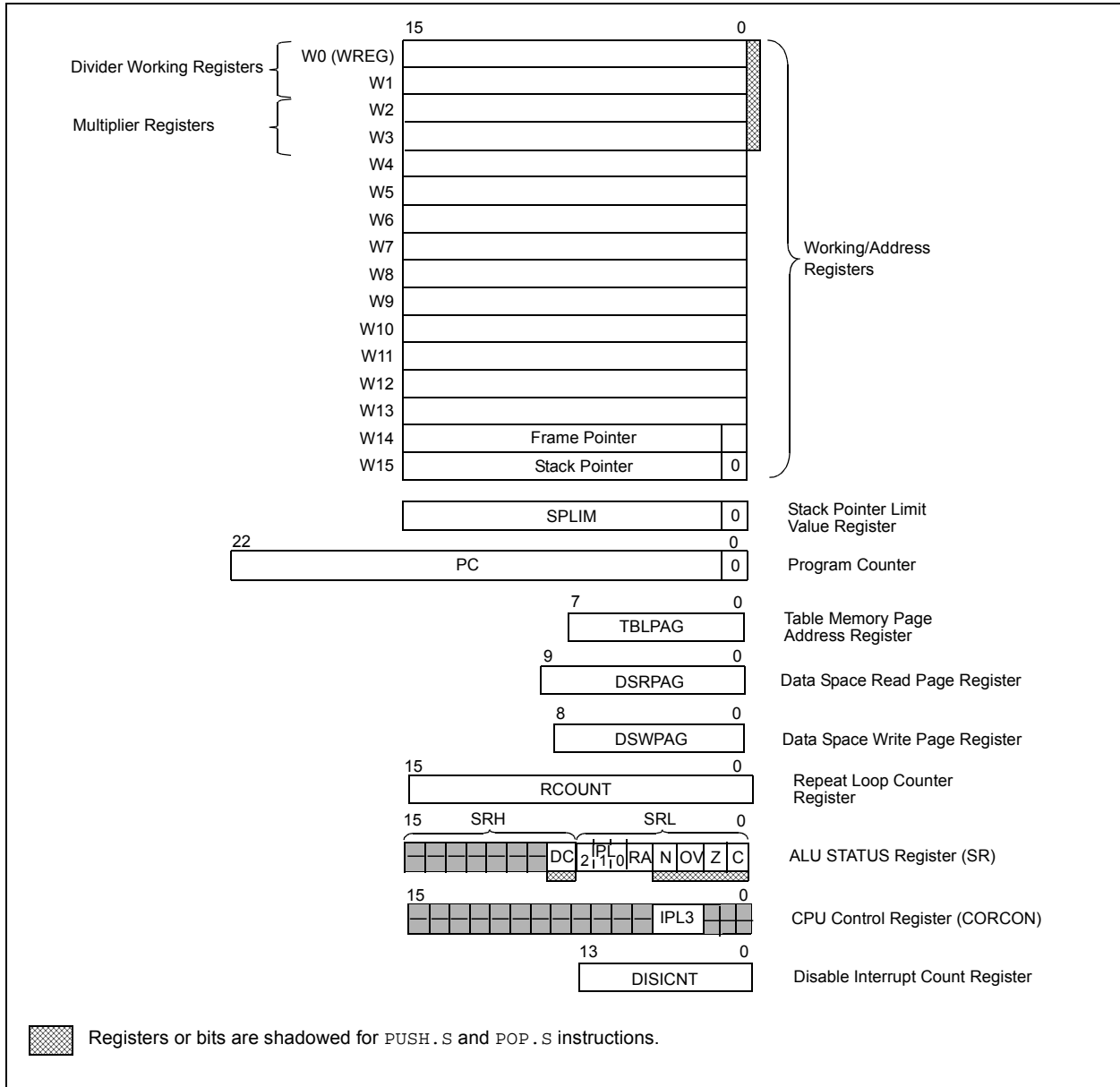

PIC24FJ256DA210 FAMILY

[查询PIC24FJ256DA106供应商](#)

3.2 CPU Control Registers

REGISTER 3-1: SR: ALU STATUS REGISTER

| | | | | | | | |
|--------|-----|-----|-----|-----|-----|-----|------------|
| U-0 | U-0 | U-0 | U-0 | U-0 | U-0 | U-0 | R/W-0, HSC |
| — | — | — | — | — | — | — | DC |
| bit 15 | | | | | | | bit 8 |

| | | | | | | | |
|---------------------------|---------------------------|---------------------------|----------|------------|------------|------------|------------|
| R/W-0, HSC ⁽¹⁾ | R/W-0, HSC ⁽¹⁾ | R/W-0, HSC ⁽¹⁾ | R-0, HSC | R/W-0, HSC | R/W-0, HSC | R/W-0, HSC | R/W-0, HSC |
| IPL2 ⁽²⁾ | IPL1 ⁽²⁾ | IPL0 ⁽²⁾ | RA | N | OV | Z | C |
| bit 7 | | | | | | | bit 0 |

| | |
|-------------------|---------------------------------------|
| Legend: | HSC = Hardware Settable/Clearable bit |
| R = Readable bit | W = Writable bit |
| -n = Value at POR | '1' = Bit is set |
| | '0' = Bit is cleared |
| | x = Bit is unknown |

- bit 15-9 **Unimplemented:** Read as '0'
- bit 8 **DC:** ALU Half Carry/Borrow bit
 1 = A carry out from the 4th low-order bit (for byte-sized data) or 8th low-order bit (for word-sized data) of the result occurred
 0 = No carry out from the 4th or 8th low-order bit of the result has occurred
- bit 7-5 **IPL<2:0>:** CPU Interrupt Priority Level Status bits^(1,2)
 111 = CPU interrupt priority level is 7 (15); user interrupts are disabled
 110 = CPU interrupt priority level is 6 (14)
 101 = CPU interrupt priority level is 5 (13)
 100 = CPU interrupt priority level is 4 (12)
 011 = CPU interrupt priority level is 3 (11)
 010 = CPU interrupt priority level is 2 (10)
 001 = CPU interrupt priority level is 1 (9)
 000 = CPU interrupt priority level is 0 (8)
- bit 4 **RA:** REPEAT Loop Active bit
 1 = REPEAT loop in progress
 0 = REPEAT loop not in progress
- bit 3 **N:** ALU Negative bit
 1 = Result was negative
 0 = Result was not negative (zero or positive)
- bit 2 **OV:** ALU Overflow bit
 1 = Overflow occurred for signed (2's complement) arithmetic in this arithmetic operation
 0 = No overflow has occurred
- bit 1 **Z:** ALU Zero bit
 1 = An operation, which affects the Z bit, has set it at some time in the past
 0 = The most recent operation, which affects the Z bit, has cleared it (i.e., a non-zero result)
- bit 0 **C:** ALU Carry/Borrow bit
 1 = A carry out from the Most Significant bit of the result occurred
 0 = No carry out from the Most Significant bit of the result occurred

- Note 1:** The IPL Status bits are read-only when NSTDIS (INTCON1<15>) = 1.
Note 2: The IPL Status bits are concatenated with the IPL3 (CORCON<3>) bit to form the CPU Interrupt Priority Level (IPL). The value in parentheses indicates the IPL when IPL3 = 1.

PIC24FJ256DA210 FAMILY

[查询PIC24FJ256DA106供应商](#)

REGISTER 3-2: CORCON: CPU CONTROL REGISTER

| | | | | | | | |
|--------|-----|-----|-----|-----|-----|-----|-------|
| U-0 | U-0 | U-0 | U-0 | U-0 | U-0 | U-0 | U-0 |
| — | — | — | — | — | — | — | — |
| bit 15 | | | | | | | bit 8 |

| | | | | | | | |
|-------|-----|-----|-----|---------------------|-----|-----|-------|
| U-0 | U-0 | U-0 | U-0 | R/C-0, HSC | R-1 | U-0 | U-0 |
| — | — | — | — | IPL3 ⁽¹⁾ | r | — | — |
| bit 7 | | | | | | | bit 0 |

| | | | |
|-------------------|-------------------|------------------------------------|---------------------------------------|
| Legend: | C = Clearable bit | r = Reserved bit | HSC = Hardware Settable/Clearable bit |
| R = Readable bit | W = Writable bit | U = Unimplemented bit, read as '0' | |
| -n = Value at POR | '1' = Bit is set | '0' = Bit is cleared | x = Bit is unknown |

bit 15-4 **Unimplemented:** Read as '0'

bit 3 **IPL3:** CPU Interrupt Priority Level Status bit⁽¹⁾
 1 = CPU interrupt priority level is greater than 7
 0 = CPU interrupt priority level is 7 or less

bit 2 **Reserved:** Read as '1'

bit 1-0 **Unimplemented:** Read as '0'

Note 1: The IPL3 bit is concatenated with the IPL<2:0> bits (SR<7:5>) to form the CPU interrupt priority level; see Register 3-1 for bit description.

3.3 Arithmetic Logic Unit (ALU)

The PIC24F ALU is 16 bits wide and is capable of addition, subtraction, bit shifts and logic operations. Unless otherwise mentioned, arithmetic operations are 2's complement in nature. Depending on the operation, the ALU may affect the values of the Carry (C), Zero (Z), Negative (N), Overflow (OV) and Digit Carry (DC) Status bits in the SR register. The C and DC Status bits operate as Borrow and Digit Borrow bits, respectively, for subtraction operations.

The ALU can perform 8-bit or 16-bit operations, depending on the mode of the instruction that is used. Data for the ALU operation can come from the W register array, or data memory, depending on the addressing mode of the instruction. Likewise, output data from the ALU can be written to the W register array or a data memory location.

The PIC24F CPU incorporates hardware support for both multiplication and division. This includes a dedicated hardware multiplier and support hardware for 16-bit divisor division.

3.3.1 MULTIPLIER

The ALU contains a high-speed, 17-bit x 17-bit multiplier. It supports unsigned, signed or mixed sign operation in several multiplication modes:

1. 16-bit x 16-bit signed
2. 16-bit x 16-bit unsigned
3. 16-bit signed x 5-bit (literal) unsigned
4. 16-bit unsigned x 16-bit unsigned
5. 16-bit unsigned x 5-bit (literal) unsigned
6. 16-bit unsigned x 16-bit signed
7. 8-bit unsigned x 8-bit unsigned

PIC24FJ256DA210 FAMILY

[查询PIC24FJ256DA106供应商](#)

3.3.2 DIVIDER

The divide block supports signed and unsigned integer divide operations with the following data sizes:

1. 32-bit signed/16-bit signed divide
2. 32-bit unsigned/16-bit unsigned divide
3. 16-bit signed/16-bit signed divide
4. 16-bit unsigned/16-bit unsigned divide

The quotient for all divide instructions ends up in W0 and the remainder in W1. 16-bit signed and unsigned `DIV` instructions can specify any W register for both the 16-bit divisor (W_n), and any W register (aligned) pair ($W(m+1):W_m$) for the 32-bit dividend. The divide algorithm takes one cycle per bit of divisor, so both 32-bit/16-bit and 16-bit/16-bit instructions take the same number of cycles to execute.

3.3.3 MULTI-BIT SHIFT SUPPORT

The PIC24F ALU supports both single bit and single-cycle, multi-bit arithmetic and logic shifts. Multi-bit shifts are implemented using a shifter block, capable of performing up to a 15-bit arithmetic right shift, or up to a 15-bit left shift, in a single cycle. All multi-bit shift instructions only support Register Direct Addressing for both the operand source and result destination.

A full summary of instructions that use the shift operation is provided in Table 3-2.

TABLE 3-2: INSTRUCTIONS THAT USE THE SINGLE BIT AND MULTI-BIT SHIFT OPERATION

| Instruction | Description |
|-------------|---|
| ASR | Arithmetic shift right source register by one or more bits. |
| SL | Shift left source register by one or more bits. |
| LSR | Logical shift right source register by one or more bits. |

PIC24FJ256DA210 FAMILY

[查询PIC24FJ256DA106供应商](#)

4.0 MEMORY ORGANIZATION

As Harvard architecture devices, PIC24F micro-controllers feature separate program and data memory spaces and busses. This architecture also allows direct access of program memory from the data space during code execution.

4.1 Program Memory Space

The program address memory space of the PIC24FJ256DA210 family devices is 4M instructions. The space is addressable by a 24-bit value derived

from either the 23-bit Program Counter (PC) during program execution, or from table operation or data space remapping, as described in **Section 4.3 “Interfacing Program and Data Memory Spaces”**.

User access to the program memory space is restricted to the lower half of the address range (000000h to 7FFFFFFh). The exception is the use of TBLRD/TBLWT operations, which use TBLPAG<7> to permit access to the Configuration bits and Device ID sections of the configuration memory space.

Memory maps for the PIC24FJ256DA210 family of devices are shown in Figure 4-1.

FIGURE 4-1: PROGRAM SPACE MEMORY MAP FOR PIC24FJ256DA210 FAMILY DEVICES

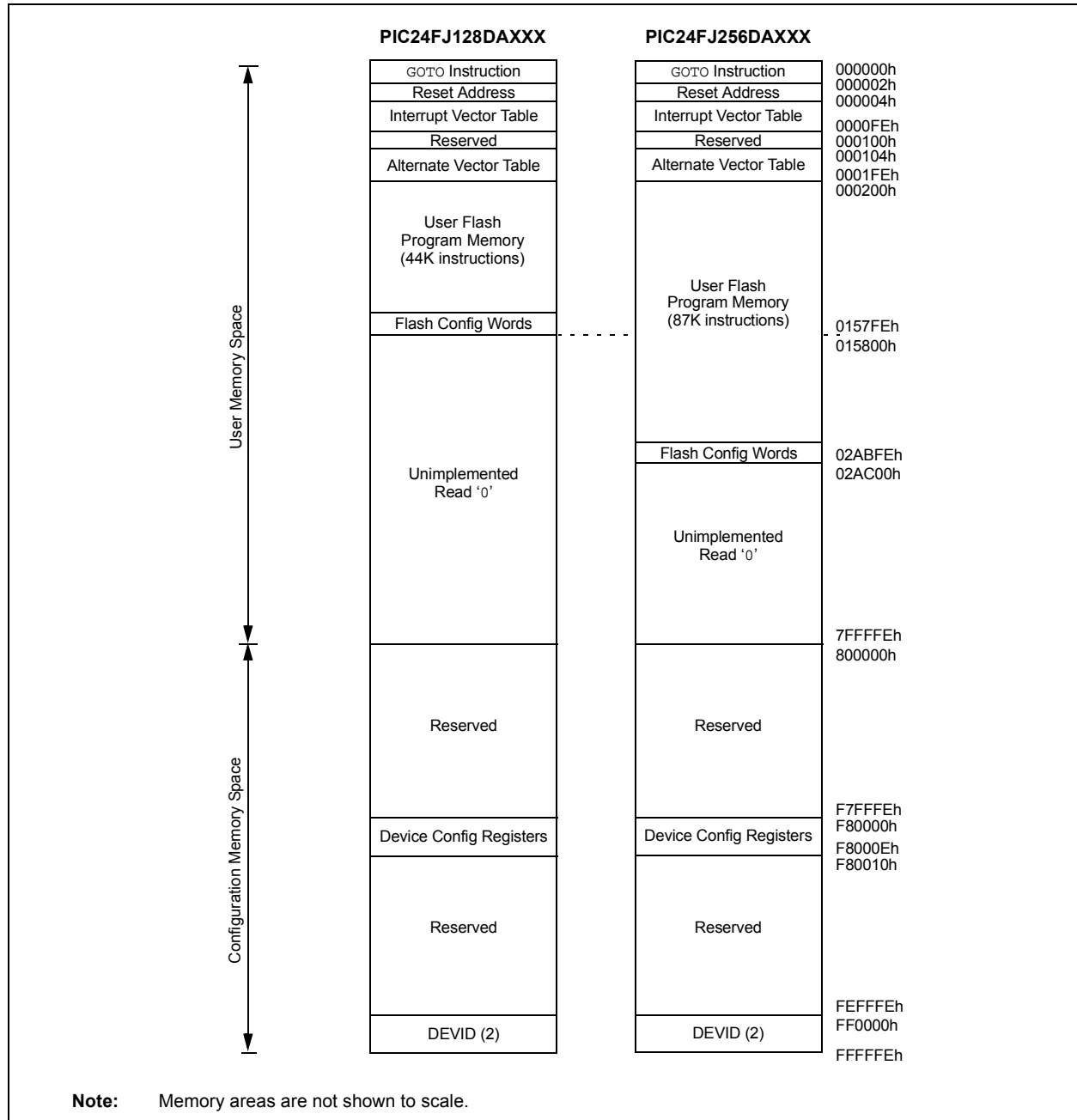

PIC24FJ256DA210 FAMILY

[查询PIC24FJ256DA106供应商](#)

4.1.1 PROGRAM MEMORY ORGANIZATION

The program memory space is organized in word-addressable blocks. Although it is treated as 24 bits wide, it is more appropriate to think of each address of the program memory as a lower and upper word, with the upper byte of the upper word being unimplemented. The lower word always has an even address, while the upper word has an odd address (Figure 4-2).

Program memory addresses are always word-aligned on the lower word and addresses are incremented or decremented by two during code execution. This arrangement also provides compatibility with data memory space addressing and makes it possible to access data in the program memory space.

4.1.2 HARD MEMORY VECTORS

All PIC24F devices reserve the addresses between 0x00000 and 0x000200 for hard coded program execution vectors. A hardware Reset vector is provided to redirect code execution from the default value of the PC on device Reset to the actual start of code. A GOTO instruction is programmed by the user at 0x000000 with the actual address for the start of code at 0x000002.

PIC24F devices also have two interrupt vector tables, located from 0x000004 to 0x0000FF and 0x000100 to 0x0001FF. These vector tables allow each of the many device interrupt sources to be handled by separate ISRs. A more detailed discussion of the interrupt vector tables is provided in **Section 7.1 “Interrupt Vector Table”**.

4.1.3 FLASH CONFIGURATION WORDS

In PIC24FJ256DA210 family devices, the top four words of on-chip program memory are reserved for configuration information. On device Reset, the configuration information is copied into the appropriate Configuration register. The addresses of the Flash Configuration Word for devices in the PIC24FJ256DA210 family are shown in Table 4-1. Their location in the memory map is shown with the other memory vectors in Figure 4-1.

The Configuration Words in program memory are a compact format. The actual Configuration bits are mapped in several different registers in the configuration memory space. Their order in the Flash Configuration Words does not reflect a corresponding arrangement in the configuration space. Additional details on the device Configuration Words are provided in **Section 27.1 “Configuration Bits”**.

TABLE 4-1: FLASH CONFIGURATION WORDS FOR PIC24FJ256DA210 FAMILY DEVICES

| Device | Program Memory (Words) | Configuration Word Addresses |
|-----------------|------------------------|------------------------------|
| PIC24FJ128DAXXX | 44,032 | 0x0157F8:0x0157FE |
| PIC24FJ256DAXXX | 87,552 | 0x02ABF8:0x02ABFE |

FIGURE 4-2: PROGRAM MEMORY ORGANIZATION

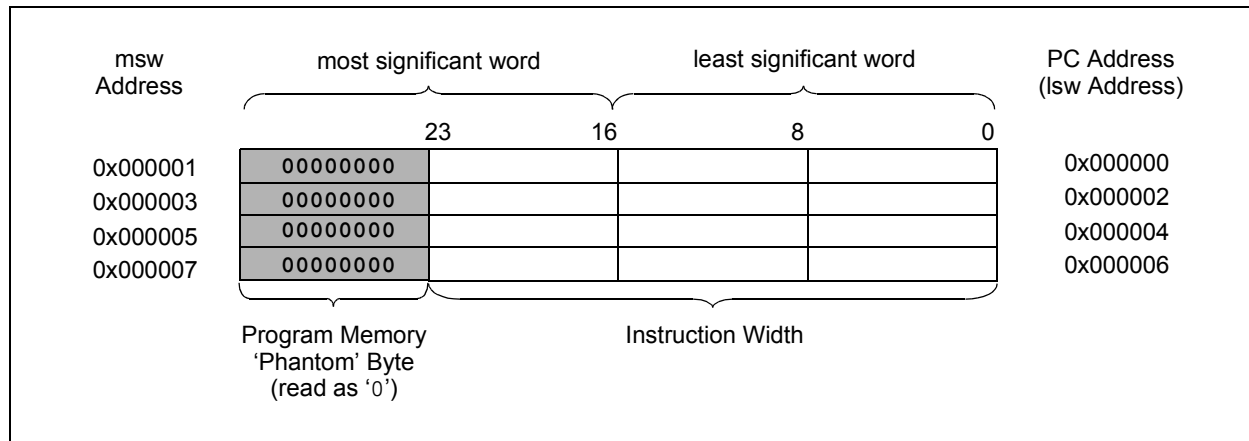

PIC24FJ256DA210 FAMILY

[查询PIC24FJ256DA106供应商](#)

4.2 Data Memory Space

Note: This data sheet summarizes the features of this group of PIC24F devices. It is not intended to be a comprehensive reference source. For more information, refer to the “PIC24F Family Reference Manual”, **Section 45. “Data Memory with Extended Data Space”** (DS39733). The information in this data sheet supersedes the information in the FRM.

The PIC24F core has a 16-bit wide data memory space, addressable as a single linear range.

The data space is accessed using two Address Generation Units (AGUs), one each for read and write operations. The data space memory map is shown in Figure 4-3.

The 16-bit wide data addresses in the data memory space point to bytes within the Data Space (DS). This gives a DS address range of 64 Kbytes or 32K words. The lower 32 Kbytes (0x0000 to 0x7FFF) of DS is compatible with the PIC24F microcontrollers without EDS.

The upper 32 Kbytes of data memory address space (0x8000 - 0xFFFF) are used as an EDS window.

The EDS window is used to access all memory region implemented in EDS, as shown in Figure 4-4.

The EDS includes any additional internal data memory not accessible by the lower 32-Kbyte data address space and any external memory through EPMP. For more details on accessing internal extended data memory, refer to the “PIC24F Family Reference Manual”, **Section 45. “Data Memory with Extended Data Space (EDS)”** (DS39733). For more details on accessing external memory using EPMP, refer to the “PIC24F Family Reference Manual”, **Section 42. “Enhanced Parallel Master Port (EPMP)”** (DS39730). In PIC24F microcontrollers with EDS, the program memory can also be read from EDS. This is called Program Space Visibility (PSV). Table 4-2 lists the total memory accessible by each of the devices in this family.

The EDS is organized as pages, with a single page called an EDS page that equals the EDS window (32 Kbytes). A particular EDS page is selected through the Data Space Read register (DSRPAG) or Data Space Write register (DSWPAG). For PSV, only the DSRPAG register is used. The combination of the DSRPAG register value and the 16-bit wide data address forms a 24-bit Effective Address (EA). For more information on EDS, refer to **Section 4.3.3 “Reading Data from Program Memory Using EDS”**.

TABLE 4-2: TOTAL MEMORY ACCESSIBLE BY THE DEVICE

| Devices | Internal RAM | External RAM Access Using EPMP | Program Memory Access Using EDS |
|-----------------|---------------------------------------|--------------------------------|---------------------------------|
| PIC24FJXXXDA210 | 96 Kbytes (30K + 66K ⁽¹⁾) | Yes (up to 16 MB) | Yes |
| PIC24FJXXXDA206 | 96 Kbytes (30K + 66K ⁽¹⁾) | No | Yes |
| PIC24FJXXXDA110 | 24 Kbytes | Yes (up to 16 MB) | Yes |
| PIC24FJXXXDA106 | 24 Kbytes | No | Yes |

Note 1: The internal RAM above 30 Kbytes can be accessed through EDS window.

PIC24FJ256DA210 FAMILY

[查询PIC24FJ256DA106供应商](#)

4.2.1 DATA SPACE WIDTH

The data memory space is organized in byte-addressable, 16-bit wide blocks. Data is aligned in data memory and registers as 16-bit words, but all data space EAs resolve to bytes. The Least Significant Bytes (LSBs) of each word have even addresses, while the Most Significant Bytes (MSBs) have odd addresses.

FIGURE 4-3: DATA SPACE MEMORY MAP FOR PIC24FJ256DA210 FAMILY DEVICES⁽⁴⁾

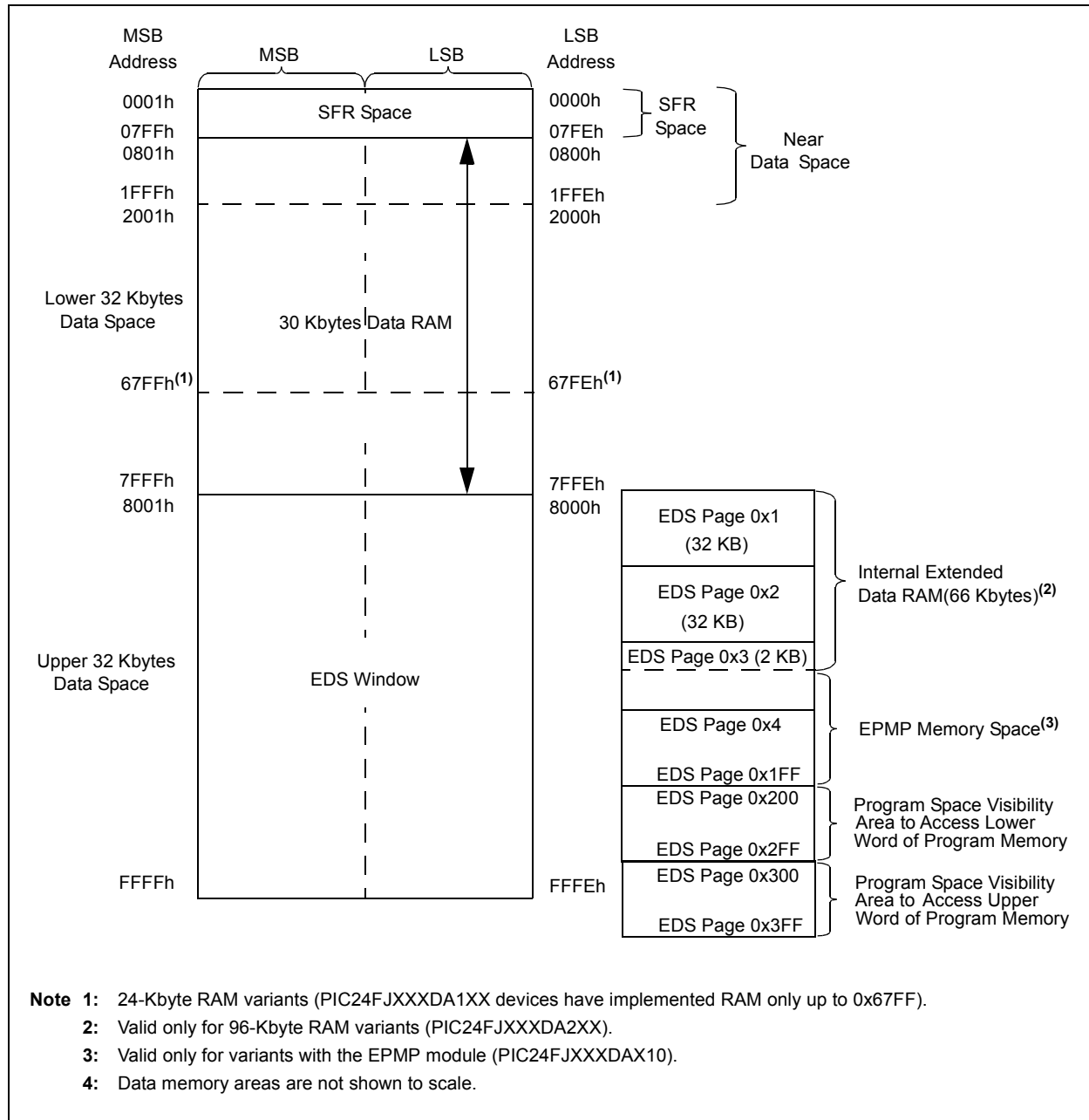

PIC24FJ256DA210 FAMILY

[查询PIC24FJ256DA106供应商](#)

4.2.2 DATA MEMORY ORGANIZATION AND ALIGNMENT

To maintain backward compatibility with PIC® MCUs and improve data space memory usage efficiency, the PIC24F instruction set supports both word and byte operations. As a consequence of byte accessibility, all EA calculations are internally scaled to step through word-aligned memory. For example, the core recognizes that Post-Modified Register Indirect Addressing mode [Ws++] will result in a value of Ws + 1 for byte operations and Ws + 2 for word operations.

Data byte reads will read the complete word, which contains the byte, using the LSB of any EA to determine which byte to select. The selected byte is placed onto the LSB of the data path. That is, data memory and registers are organized as two parallel, byte-wide entities with shared (word) address decode but separate write lines. Data byte writes only write to the corresponding side of the array or register which matches the byte address.

All word accesses must be aligned to an even address. Misaligned word data fetches are not supported, so care must be taken when mixing byte and word operations or translating from 8-bit MCU code. If a misaligned read or write is attempted, an address error trap will be generated. If the error occurred on a read, the instruction underway is completed; if it occurred on a write, the instruction will be executed but the write will not occur. In either case, a trap is then executed, allowing the system and/or user to examine the machine state prior to execution of the address Fault.

All byte loads into any W register are loaded into the LSB. The Most Significant Byte (MSB) is not modified.

A sign-extend instruction (SE) is provided to allow users to translate 8-bit signed data to 16-bit signed values. Alternatively, for 16-bit unsigned data, users

can clear the MSB of any W register by executing a zero-extend (ZE) instruction on the appropriate address.

Although most instructions are capable of operating on word or byte data sizes, it should be noted that some instructions operate only on words.

4.2.3 NEAR DATA SPACE

The 8-Kbyte area between 0000h and 1FFFh is referred to as the near data space. Locations in this space are directly addressable via a 13-bit absolute address field within all memory direct instructions. The remainder of the data space is addressable indirectly. Additionally, the whole data space is addressable using MOV instructions, which support Memory Direct Addressing with a 16-bit address field.

4.2.4 SPECIAL FUNCTION REGISTER (SFR) SPACE

The first 2 Kbytes of the near data space, from 0000h to 07FFh, are primarily occupied with Special Function Registers (SFRs). These are used by the PIC24F core and peripheral modules for controlling the operation of the device.

SFRs are distributed among the modules that they control and are generally grouped together by module. Much of the SFR space contains unused addresses; these are read as '0'. A diagram of the SFR space, showing where the SFRs are actually implemented, is shown in Table 4-3. Each implemented area indicates a 32-byte region where at least one address is implemented as an SFR. A complete list of implemented SFRs, including their addresses, is shown in Tables 4-4 through Table 4-34.

TABLE 4-3: IMPLEMENTED REGIONS OF SFR DATA SPACE

| SFR Space Address | | | | | | | | |
|-------------------|-------------------|----------|----------|----------------------|------------|------|------|-------|
| | xx00 | xx20 | xx40 | xx60 | xx80 | xxA0 | xxC0 | xxE0 |
| 000h | Core | | | ICN | Interrupts | | | |
| 100h | Timers | | Capture | | Compare | | | |
| 200h | I ² C™ | UART | SPI/UART | SPI/I ² C | SPI | UART | I/O | |
| 300h | ADC/CTMU | | | — | — | — | — | — |
| 400h | — | — | — | — | USB | | | ANSEL |
| 500h | — | — | — | — | — | — | — | — |
| 600h | EPMP | RTC/Comp | CRC | — | PPS | | | — |
| 700h | GFX Controller | | System | NVM/PMD | — | — | — | — |

Legend: — = No implemented SFRs in this block

PIC24FJ256DA210 FAMILY

[查询PIC24FJ256DA106供应商](#)

TABLE 4-4: CPU CORE REGISTERS MAP

| File Name | Addr | Bit 15 | Bit 14 | Bit 13 | Bit 12 | Bit 11 | Bit 10 | Bit 9 | Bit 8 | Bit 7 | Bit 6 | Bit 5 | Bit 4 | Bit 3 | Bit 2 | Bit 1 | Bit 0 | All Resets |
|-----------------------|------|--------|--------|--------|--------|--------|--------|-------|-------|-------|-------|-------|-------|-------|-------|-------|-------|------------|
| WREG0 | 0000 | | | | | | | | | | | | | | | | | 0000 |
| WREG1 | 0002 | | | | | | | | | | | | | | | | | 0000 |
| WREG2 | 0004 | | | | | | | | | | | | | | | | | 0000 |
| WREG3 | 0006 | | | | | | | | | | | | | | | | | 0000 |
| WREG4 | 0008 | | | | | | | | | | | | | | | | | 0000 |
| WREG5 | 000A | | | | | | | | | | | | | | | | | 0000 |
| WREG6 | 000C | | | | | | | | | | | | | | | | | 0000 |
| WREG7 | 000E | | | | | | | | | | | | | | | | | 0000 |
| WREG8 | 0010 | | | | | | | | | | | | | | | | | 0000 |
| WREG9 | 0012 | | | | | | | | | | | | | | | | | 0000 |
| WREG10 | 0014 | | | | | | | | | | | | | | | | | 0000 |
| WREG11 | 0016 | | | | | | | | | | | | | | | | | 0000 |
| WREG12 | 0018 | | | | | | | | | | | | | | | | | 0000 |
| WREG13 | 001A | | | | | | | | | | | | | | | | | 0000 |
| WREG14 | 001C | | | | | | | | | | | | | | | | | 0000 |
| WREG15 | 001E | | | | | | | | | | | | | | | | | 0000 |
| SPLIM | 0020 | | | | | | | | | | | | | | | | | 0800 |
| PCL | 002E | | | | | | | | | | | | | | | | | xxxx |
| PCH | 0030 | — | — | — | — | — | — | — | — | — | — | — | — | — | — | — | — | 0000 |
| DSRPAG | 0032 | — | — | — | — | — | — | — | — | — | — | — | — | — | — | — | — | 0001 |
| DSWPAG ⁽¹⁾ | 0034 | — | — | — | — | — | — | — | — | — | — | — | — | — | — | — | — | 0001 |
| RCOUNT | 0036 | | | | | | | | | | | | | | | | | xxxx |
| SR | 0042 | — | — | — | — | — | — | — | DC | IPL2 | IPL1 | IPL0 | RA | N | OV | Z | C | 0000 |
| CORCON | 0044 | — | — | — | — | — | — | — | — | — | — | — | — | IPL3 | r | — | — | 0004 |
| DISICNT | 0052 | — | — | — | — | — | — | — | — | — | — | — | — | — | — | — | — | xxxx |
| TBLPAG | 0054 | — | — | — | — | — | — | — | — | — | — | — | — | — | — | — | — | 0000 |

Legend: — = unimplemented, read as '0'; r = Reserved bit. Reset values are shown in hexadecimal.
Note 1: Reserved in PIC24FJXXDA106 devices; do not use.

PIC24FJ256DA210 FAMILY

查询PIC24FJ256DA106供应商

TABLE 4-5: ICN REGISTER MAP

| File Name | Addr | Bit 15 | Bit 14 | Bit 13 | Bit 12 | Bit 11 | Bit 10 | Bit 9 | Bit 8 | Bit 7 | Bit 6 | Bit 5 | Bit 4 | Bit 3 | Bit 2 | Bit 1 | Bit 0 | All Resets |
|-----------|------|------------------------|------------------------|------------------------|------------------------|------------------------|------------------------|------------------------|------------------------|------------------------|------------------------|------------------------|------------------------|------------------------|------------------------|------------------------|------------------------|------------|
| CNPD1 | 0056 | CN15PDE | CN14PDE | CN13PDE | CN12PDE | CN11PDE | CN10PDE | CN9PDE | CN8PDE | CN7PDE | CN6PDE | CN5PDE | CN4PDE | CN3PDE | CN2PDE | CN1PDE | CN0PDE | 0000 |
| CNPD2 | 0058 | CN31PDE | CN30PDE | CN29PDE | CN28PDE | CN27PDE | CN26PDE | CN25PDE | CN24PDE | CN23PDE | CN22PDE | CN21PDE ⁽¹⁾ | CN20PDE ⁽¹⁾ | CN19PDE ⁽¹⁾ | CN18PDE | CN17PDE | CN16PDE | 0000 |
| CNPD3 | 005A | CN47PDE ⁽¹⁾ | CN46PDE ⁽¹⁾ | CN45PDE ⁽¹⁾ | CN44PDE ⁽¹⁾ | CN43PDE ⁽¹⁾ | CN42PDE ⁽¹⁾ | CN41PDE ⁽¹⁾ | CN40PDE ⁽¹⁾ | CN39PDE ⁽¹⁾ | CN38PDE ⁽¹⁾ | CN37PDE ⁽¹⁾ | CN36PDE ⁽¹⁾ | CN35PDE ⁽¹⁾ | CN34PDE ⁽¹⁾ | CN33PDE ⁽¹⁾ | CN32PDE | 0000 |
| CNPD4 | 005C | CN63PDE | CN62PDE | CN61PDE | CN60PDE | CN59PDE | CN58PDE | CN57PDE ⁽¹⁾ | CN56PDE | CN55PDE | CN54PDE | CN53PDE | CN52PDE | CN51PDE | CN50PDE | CN49PDE | CN48PDE ⁽¹⁾ | 0000 |
| CNPD5 | 005E | CN79PDE ⁽¹⁾ | CN78PDE ⁽¹⁾ | CN77PDE ⁽¹⁾ | CN76PDE ⁽¹⁾ | CN75PDE ⁽¹⁾ | CN74PDE ⁽¹⁾ | CN73PDE ⁽¹⁾ | — | — | CN70PDE ⁽¹⁾ | CN69PDE | CN68PDE | CN67PDE ⁽¹⁾ | CN66PDE ⁽¹⁾ | CN65PDE | CN64PDE | 0000 |
| CNPD6 | 0060 | — | — | — | — | — | — | — | — | — | — | — | CN84PDE | CN83PDE | CN82PDE ⁽¹⁾ | CN81PDE ⁽¹⁾ | CN80PDE ⁽¹⁾ | 0000 |
| CNEN1 | 0062 | CN15IE | CN14IE | CN13IE | CN12IE | CN11IE | CN10IE | CN9IE | CN8IE | CN7IE | CN6IE | CN5IE | CN4IE | CN3IE | CN2IE | CN1IE | CN0IE | 0000 |
| CNEN2 | 0064 | CN31IE | CN30IE | CN29IE | CN28IE | CN27IE | CN26IE | CN25IE | CN24IE | CN23IE | CN22IE | CN21IE ⁽¹⁾ | CN20IE ⁽¹⁾ | CN19IE ⁽¹⁾ | CN18IE | CN17IE | CN16IE | 0000 |
| CNEN3 | 0066 | CN47IE ⁽¹⁾ | CN46IE ⁽¹⁾ | CN45IE ⁽¹⁾ | CN44IE ⁽¹⁾ | CN43IE ⁽¹⁾ | CN42IE ⁽¹⁾ | CN41IE ⁽¹⁾ | CN40IE ⁽¹⁾ | CN39IE ⁽¹⁾ | CN38IE ⁽¹⁾ | CN37IE ⁽¹⁾ | CN36IE ⁽¹⁾ | CN35IE ⁽¹⁾ | CN34IE ⁽¹⁾ | CN33IE ⁽¹⁾ | CN32IE | 0000 |
| CNEN4 | 0068 | CN63IE | CN62IE | CN61IE | CN60IE | CN59IE | CN58IE | CN57IE ⁽¹⁾ | CN56IE | CN55IE | CN54IE | CN53IE | CN52IE | CN51IE | CN50IE | CN49IE | CN48IE ⁽¹⁾ | 0000 |
| CNEN5 | 006A | CN79IE ⁽¹⁾ | CN78IE ⁽¹⁾ | CN77IE ⁽¹⁾ | CN76IE ⁽¹⁾ | CN75IE ⁽¹⁾ | CN74IE ⁽¹⁾ | CN73IE ⁽¹⁾ | — | — | CN70IE ⁽¹⁾ | CN69IE | CN68IE | CN67IE ⁽¹⁾ | CN66IE ⁽¹⁾ | CN65IE | CN64IE | 0000 |
| CNEN6 | 006C | — | — | — | — | — | — | — | — | — | — | — | CN84IE | CN83IE | CN82IE ⁽¹⁾ | CN81IE ⁽¹⁾ | CN80IE ⁽¹⁾ | 0000 |
| CNPU1 | 006E | CN15PUE | CN14PUE | CN13PUE | CN12PUE | CN11PUE | CN10PUE | CN9PUE | CN8PUE | CN7PUE | CN6PUE | CN5PUE | CN4PUE | CN3PUE | CN2PUE | CN1PUE | CN0PUE | 0000 |
| CNPU2 | 0070 | CN31PUE | CN30PUE | CN29PUE | CN28PUE | CN27PUE | CN26PUE | CN25PUE | CN24PUE | CN23PUE | CN22PUE | CN21PUE ⁽¹⁾ | CN20PUE ⁽¹⁾ | CN19PUE ⁽¹⁾ | CN18PUE | CN17PUE | CN16PUE | 0000 |
| CNPU3 | 0072 | CN47PUE ⁽¹⁾ | CN46PUE ⁽¹⁾ | CN45PUE ⁽¹⁾ | CN44PUE ⁽¹⁾ | CN43PUE ⁽¹⁾ | CN42PUE ⁽¹⁾ | CN41PUE ⁽¹⁾ | CN40PUE ⁽¹⁾ | CN39PUE ⁽¹⁾ | CN38PUE ⁽¹⁾ | CN37PUE ⁽¹⁾ | CN36PUE ⁽¹⁾ | CN35PUE ⁽¹⁾ | CN34PUE ⁽¹⁾ | CN33PUE ⁽¹⁾ | CN32PUE | 0000 |
| CNPU4 | 0074 | CN63PUE | CN62PUE | CN61PUE | CN60PUE | CN59PUE | CN58PUE | CN57PUE ⁽¹⁾ | CN56PUE | CN55PUE | CN54PUE | CN53PUE | CN52PUE | CN51PUE | CN50PUE | CN49PUE | CN48PUE ⁽¹⁾ | 0000 |
| CNPU5 | 0076 | CN79PUE ⁽¹⁾ | CN78PUE ⁽¹⁾ | CN77PUE ⁽¹⁾ | CN76PUE ⁽¹⁾ | CN75PUE ⁽¹⁾ | CN74PUE ⁽¹⁾ | CN73PUE ⁽¹⁾ | — | — | CN70PUE ⁽¹⁾ | CN69PUE | CN68PUE | CN67PUE ⁽¹⁾ | CN66PUE ⁽¹⁾ | CN65PUE | CN64PUE | 0000 |
| CNPU6 | 0078 | — | — | — | — | — | — | — | — | — | — | — | CN84PUE | CN83PUE | CN82PUE ⁽¹⁾ | CN81PUE ⁽¹⁾ | CN80PUE ⁽¹⁾ | 0000 |

Legend:
 Note 1: — = unimplemented; read as '0'. Reset values are shown in hexadecimal. Unimplemented in 64-pin devices; read as '0'.

PIC24FJ256DA210 FAMILY

查询PIC24FJ256DA106供应商

TABLE 4-6: INTERRUPT CONTROLLER REGISTER MAP

| File Name | Addr | Bit 15 | Bit 14 | Bit 13 | Bit 12 | Bit 11 | Bit 10 | Bit 9 | Bit 8 | Bit 7 | Bit 6 | Bit 5 | Bit 4 | Bit 3 | Bit 2 | Bit 1 | Bit 0 | All Resets |
|-----------|------|--------|---------|-----------|---------|--------|---------|---------|---------|--------|-----------|-----------|-----------|---------|---------|---------|---------|------------|
| INTCON1 | 0080 | — | — | — | — | — | — | — | — | — | — | — | MATHERR | ADDRERR | STKERR | OSCFAIL | — | 0000 |
| INTCON2 | 0082 | ALTVT | DISI | — | — | — | — | — | — | — | — | — | INT4EP | INT3EP | INT2EP | INT1EP | INT0EP | 0000 |
| IFS0 | 0084 | — | — | AD1IF | U1TXIF | U1RXIF | SP11IF | SP11IF | T3IF | T2IF | OC2IF | IC2IF | — | T1IF | OC1IF | IC1IF | INT0IF | 0000 |
| IFS1 | 0086 | U2TXIF | U2RXIF | INT2IF | T5IF | T4IF | OC4IF | OC3IF | — | IC8IF | IC7IF | — | INT1IF | CNIF | CMIF | M2C1IF | S2C1IF | 0000 |
| IFS2 | 0088 | — | — | PMP1P(1) | OC8IF | OC7IF | OC6IF | OC5IF | IC6IF | IC5IF | IC4IF | IC3IF | — | — | — | SP12IF | SPF2IF | 0000 |
| IFS3 | 008A | — | RTCIF | — | — | — | — | — | — | — | INT4IF | INT3IF | — | — | M2C2IF | S2C2IF | — | 0000 |
| IFS4 | 008C | — | — | CTMUJIF | — | — | — | — | LVDFIF | — | — | — | — | — | U2ERIF | U1ERIF | — | 0000 |
| IFS5 | 008E | — | — | IC9IF | OC9IF | SP13IF | SPF3IF | U4TXIF | U4RXIF | U4ERIF | USB1IF | M2C3IF | S2C3IF | U3TXIF | U3RXIF | U3ERIF | — | 0000 |
| IFS6 | 0090 | — | — | — | — | — | — | — | — | — | — | — | GFX1IF | — | — | — | — | 0000 |
| IEC0 | 0094 | — | — | AD1IE | U1TXIE | U1RXIE | SP11IE | SPF11IE | T3IE | T2IE | OC2IE | IC2IE | — | T1IE | OC1IE | IC1IE | INT0IE | 0000 |
| IEC1 | 0096 | U2TXIE | U2RXIE | INT2IE | T5IE | T4IE | OC4IE | OC3IE | — | IC8IE | IC7IE | — | INT1IE | CNIE | CMIE | M2C1IE | S2C1IE | 0000 |
| IEC2 | 0098 | — | — | PMP1IE(1) | OC8IE | OC7IE | OC6IE | OC5IE | IC6IE | IC5IE | IC4IE | IC3IE | — | — | — | SP12IE | SPF2IE | 0000 |
| IEC3 | 009A | — | RTCIE | — | — | — | — | — | — | — | INT4IE | INT3IE | — | — | M2C2IE | S2C2IE | — | 0000 |
| IEC4 | 009C | — | — | CTMUJIE | — | — | — | — | LVDFIE | — | — | — | — | — | U2ERIE | U1ERIE | — | 0000 |
| IEC5 | 009E | — | — | IC9IE | OC9IE | SP13IE | SPF3IE | U4TXIE | U4RXIE | U4ERIE | USB1IE | M2C3IE | S2C3IE | U3TXIE | U3RXIE | U3ERIE | — | 0000 |
| IEC6 | 00A0 | — | — | — | — | — | — | — | — | — | — | — | GFX1IE | — | — | — | — | 0000 |
| IPC0 | 00A4 | — | T1IP2 | T1IP1 | T1IP0 | — | OC1IP2 | OC1IP1 | OC1IP0 | — | IC1IP2 | IC1IP1 | IC1IP0 | — | INT0IP2 | INT0IP1 | INT0IP0 | 4444 |
| IPC1 | 00A6 | — | T2IP2 | T2IP1 | T2IP0 | — | OC2IP2 | OC2IP1 | OC2IP0 | — | IC2IP2 | IC2IP1 | IC2IP0 | — | — | — | — | 4444 |
| IPC2 | 00A8 | — | U1RXIP2 | U1RXIP1 | U1RXIP0 | — | SP11IP2 | SP11IP1 | SP11IP0 | — | SPF1IP2 | SPF1IP1 | SPF1IP0 | — | T3IP2 | T3IP1 | T3IP0 | 4444 |
| IPC3 | 00AA | — | — | — | — | — | — | — | — | — | AD1IP2 | AD1IP1 | AD1IP0 | — | U1TXIP2 | U1TXIP1 | U1TXIP0 | 0044 |
| IPC4 | 00AC | — | CNIP2 | CNIP1 | CNIP0 | — | CMIP2 | CMIP1 | CMIP0 | — | M2C1IP2 | M2C1IP1 | M2C1IP0 | — | S2C1IP2 | S2C1IP1 | S2C1IP0 | 4444 |
| IPC5 | 00AE | — | IC8IP2 | IC8IP1 | IC8IP0 | — | IC7IP2 | IC7IP1 | IC7IP0 | — | — | — | — | — | INT1IP2 | INT1IP1 | INT1IP0 | 4404 |
| IPC6 | 00B0 | — | T4IP2 | T4IP1 | T4IP0 | — | OC4IP2 | OC4IP1 | OC4IP0 | — | OC3IP2 | OC3IP1 | OC3IP0 | — | — | — | — | 4440 |
| IPC7 | 00B2 | — | U2TXIP2 | U2TXIP1 | U2TXIP0 | — | U2RXIP2 | U2RXIP1 | U2RXIP0 | — | INT2IP2 | INT2IP1 | INT2IP0 | — | T5IP2 | T5IP1 | T5IP0 | 4444 |
| IPC8 | 00B4 | — | — | — | — | — | — | — | — | — | SP12IP2 | SP12IP1 | SP12IP0 | — | SPF2IP2 | SPF2IP1 | SPF2IP0 | 0044 |
| IPC9 | 00B6 | — | IC5IP2 | IC5IP1 | IC5IP0 | — | IC4IP2 | IC4IP1 | IC4IP0 | — | IC3IP2 | IC3IP1 | IC3IP0 | — | — | — | — | 4440 |
| IPC10 | 00B8 | — | OC7IP2 | OC7IP1 | OC7IP0 | — | OC6IP2 | OC6IP1 | OC6IP0 | — | OC5IP2 | OC5IP1 | OC5IP0 | — | IC6IP2 | IC6IP1 | IC6IP0 | 4444 |
| IPC11 | 00BA | — | — | — | — | — | — | — | — | — | PMP1P2(1) | PMP1P1(1) | PMP1P0(1) | — | OC8IP2 | OC8IP1 | OC8IP0 | 0044(2) |
| IPC12 | 00BC | — | — | — | — | — | M2C2IP2 | M2C2IP1 | M2C2IP0 | — | S2C2IP2 | S2C2IP1 | S2C2IP0 | — | — | — | — | 0440 |
| IPC13 | 00BE | — | — | — | — | — | INT4IP2 | INT4IP1 | INT4IP0 | — | INT3IP2 | INT3IP1 | INT3IP0 | — | — | — | — | 0440 |
| IPC15 | 00C2 | — | — | — | — | — | RTCIP2 | RTCIP1 | RTCIP0 | — | — | — | — | — | — | — | — | 0400 |

Legend: — = unimplemented, read as '0'. Reset values are shown in hexadecimal.

Note 1: Unimplemented in 64-pin devices, read as '0'.

Note 2: The Reset value in 64-pin devices are '0004'.

TABLE 4-6: INTERRUPT CONTROLLER REGISTER MAP (CONTINUED)

| File Name | Addr | Bit 15 | Bit 14 | Bit 13 | Bit 12 | Bit 11 | Bit 10 | Bit 9 | Bit 8 | Bit 7 | Bit 6 | Bit 5 | Bit 4 | Bit 3 | Bit 2 | Bit 1 | Bit 0 | All Resets |
|-----------|------|--------|---------|---------|---------|--------|---------|---------|---------|-------|----------|----------|----------|---------|----------|----------|----------|------------|
| IPC16 | 00C4 | — | CRCIP2 | CRCIP1 | CRCIP0 | — | U2ERIP2 | U2ERIP1 | U2ERIP0 | — | U1ERIP2 | U1ERIP1 | U1ERIP0 | — | — | — | LVDIP0 | 4440 |
| IPC18 | 00C8 | — | — | — | — | — | — | — | — | — | — | — | — | — | — | LVDIP1 | LVDIP0 | 0004 |
| IPC19 | 00CA | — | — | — | — | — | — | — | — | — | CTMUJIP2 | CTMUJIP1 | CTMUJIP0 | — | — | — | — | 0040 |
| IPC20 | 00CC | — | U3TXIP2 | U3TXIP1 | U3TXIP0 | — | U3RXIP2 | U3RXIP1 | U3RXIP0 | — | U3ERIP2 | U3ERIP1 | U3ERIP0 | — | — | — | — | 4440 |
| IPC21 | 00CE | — | U4ERIP2 | U4ERIP1 | U4ERIP0 | — | USB1IP2 | USB1IP1 | USB1IP0 | — | M2C3IP2 | M2C3IP1 | M2C3IP0 | — | S12C3IP2 | S12C3IP1 | S12C3IP0 | 4444 |
| IPC22 | 00D0 | — | SP13IP2 | SP13IP1 | SP13IP0 | — | SPF3IP2 | SPF3IP1 | SPF3IP0 | — | U4TXIP2 | U4TXIP1 | U4TXIP0 | — | U4RXIP2 | U4RXIP1 | U4RXIP0 | 4444 |
| IPC23 | 00D2 | — | — | — | — | — | — | — | — | — | IC9IP2 | IC9IP1 | IC9IP0 | — | OC9IP2 | OC9IP1 | OC9IP0 | 0044 |
| IPC25 | 00D6 | — | — | — | — | — | — | — | — | — | — | — | — | — | GFX1IP2 | GFX1IP1 | GFX1IP0 | 0004 |
| INTTREG | 00E0 | CPJIRQ | — | VHOLD | — | ILR3 | ILR2 | ILR1 | ILR0 | — | VECNUM6 | VECNUM5 | VECNUM4 | VECNUM3 | VECNUM2 | VECNUM1 | VECNUM0 | 0000 |

Legend: — = unimplemented, read as '0'. Reset values are shown in hexadecimal.

Note 1: Unimplemented in 64-pin devices, read as '0'.

Note 2: The Reset value in 64-pin devices are '0004'.

TABLE 4-7: TIMER REGISTER MAP

| File Name | Addr | Bit 15 | Bit 14 | Bit 13 | Bit 12 | Bit 11 | Bit 10 | Bit 9 | Bit 8 | Bit 7 | Bit 6 | Bit 5 | Bit 4 | Bit 3 | Bit 2 | Bit 1 | Bit 0 | All Resets | |
|-----------|------|--|--------|--------|--------|--------|--------|-------|-------|-------|-------|--------|--------|-------|-------|-------|-------|------------|------|
| TMR1 | 0100 | Timer1 Register | | | | | | | | | | | | | | | | | 0000 |
| PR1 | 0102 | Timer1 Period Register | | | | | | | | | | | | | | | | | FFFF |
| T1CON | 0104 | TON | — | TSIDL | — | — | — | — | — | — | TGATE | TCKPS1 | TCKPS0 | — | TSYNC | TCS | — | 0000 | |
| TMR2 | 0106 | Timer2 Register | | | | | | | | | | | | | | | | | 0000 |
| TMR3-HLD | 0108 | Timer3 Holding Register (for 32-bit timer operations only) | | | | | | | | | | | | | | | | | 0000 |
| TMR3 | 010A | Timer3 Register | | | | | | | | | | | | | | | | | 0000 |
| PR2 | 010C | Timer2 Period Register | | | | | | | | | | | | | | | | | FFFF |
| PR3 | 010E | Timer3 Period Register | | | | | | | | | | | | | | | | | FFFF |
| T2CON | 0110 | TON | — | TSIDL | — | — | — | — | — | — | TGATE | TCKPS1 | TCKPS0 | T32 | — | TCS | — | 0000 | |
| T3CON | 0112 | TON | — | TSIDL | — | — | — | — | — | — | TGATE | TCKPS1 | TCKPS0 | — | — | TCS | — | 0000 | |
| TMR4 | 0114 | Timer4 Register | | | | | | | | | | | | | | | | | 0000 |
| TMR5-HLD | 0116 | Timer5 Holding Register (for 32-bit operations only) | | | | | | | | | | | | | | | | | 0000 |
| TMR5 | 0118 | Timer5 Register | | | | | | | | | | | | | | | | | 0000 |
| PR4 | 011A | Timer4 Period Register | | | | | | | | | | | | | | | | | FFFF |
| PR5 | 011C | Timer5 Period Register | | | | | | | | | | | | | | | | | FFFF |
| T4CON | 011E | TON | — | TSIDL | — | — | — | — | — | — | TGATE | TCKPS1 | TCKPS0 | T45 | — | TCS | — | 0000 | |
| T5CON | 0120 | TON | — | TSIDL | — | — | — | — | — | — | TGATE | TCKPS1 | TCKPS0 | — | — | TCS | — | 0000 | |

Legend: — = unimplemented, read as '0'. Reset values are shown in hexadecimal.

PIC24FJ256DA210 FAMILY

查询PIC24FJ256DA106供应商

TABLE 4-8: INPUT CAPTURE REGISTER MAP

| File Name | Addr | Bit 15 | Bit 14 | Bit 13 | Bit 12 | Bit 11 | Bit 10 | Bit 9 | Bit 8 | Bit 7 | Bit 6 | Bit 5 | Bit 4 | Bit 3 | Bit 2 | Bit 1 | Bit 0 | All Resets |
|-----------|------|--------------------------------------|--------|--------|---------|---------|---------|-------|-------|--------|----------|-------|----------|----------|----------|----------|----------|------------|
| IC1CON1 | 0140 | — | — | ICSIDL | ICTSEL2 | ICTSEL1 | ICTSELO | — | — | — | IC11 | IC10 | ICOV | ICBNE | ICM2 | ICM1 | ICM0 | 0000 |
| IC1CON2 | 0142 | — | — | — | — | — | — | — | IC32 | ICTRIG | TRIGSTAT | — | SYNCSEL4 | SYNCSEL3 | SYNCSEL2 | SYNCSEL1 | SYNCSELO | 0000 |
| IC1BUF | 0144 | Input Capture 1 Buffer Register | | | | | | | | | | | | | | | | |
| IC1TMR | 0146 | Input Capture 1 Timer Value Register | | | | | | | | | | | | | | | | |
| IC2CON1 | 0148 | — | — | ICSIDL | ICTSEL2 | ICTSEL1 | ICTSELO | — | — | — | IC11 | IC10 | ICOV | ICBNE | ICM2 | ICM1 | ICM0 | 0000 |
| IC2CON2 | 014A | — | — | — | — | — | — | — | IC32 | ICTRIG | TRIGSTAT | — | SYNCSEL4 | SYNCSEL3 | SYNCSEL2 | SYNCSEL1 | SYNCSELO | 0000 |
| IC2BUF | 014C | Input Capture 2 Buffer Register | | | | | | | | | | | | | | | | |
| IC2TMR | 014E | Input Capture 2 Timer Value Register | | | | | | | | | | | | | | | | |
| IC3CON1 | 0150 | — | — | ICSIDL | ICTSEL2 | ICTSEL1 | ICTSELO | — | — | — | IC11 | IC10 | ICOV | ICBNE | ICM2 | ICM1 | ICM0 | 0000 |
| IC3CON2 | 0152 | — | — | — | — | — | — | — | IC32 | ICTRIG | TRIGSTAT | — | SYNCSEL4 | SYNCSEL3 | SYNCSEL2 | SYNCSEL1 | SYNCSELO | 0000 |
| IC3BUF | 0154 | Input Capture 3 Buffer Register | | | | | | | | | | | | | | | | |
| IC3TMR | 0156 | Input Capture 3 Timer Value Register | | | | | | | | | | | | | | | | |
| IC4CON1 | 0158 | — | — | ICSIDL | ICTSEL2 | ICTSEL1 | ICTSELO | — | — | — | IC11 | IC10 | ICOV | ICBNE | ICM2 | ICM1 | ICM0 | 0000 |
| IC4CON2 | 015A | — | — | — | — | — | — | — | IC32 | ICTRIG | TRIGSTAT | — | SYNCSEL4 | SYNCSEL3 | SYNCSEL2 | SYNCSEL1 | SYNCSELO | 0000 |
| IC4BUF | 015C | Input Capture 4 Buffer Register | | | | | | | | | | | | | | | | |
| IC4TMR | 015E | Input Capture 4 Timer Value Register | | | | | | | | | | | | | | | | |
| IC5CON1 | 0160 | — | — | ICSIDL | ICTSEL2 | ICTSEL1 | ICTSELO | — | — | — | IC11 | IC10 | ICOV | ICBNE | ICM2 | ICM1 | ICM0 | 0000 |
| IC5CON2 | 0162 | — | — | — | — | — | — | — | IC32 | ICTRIG | TRIGSTAT | — | SYNCSEL4 | SYNCSEL3 | SYNCSEL2 | SYNCSEL1 | SYNCSELO | 0000 |
| IC5BUF | 0164 | Input Capture 5 Buffer Register | | | | | | | | | | | | | | | | |
| IC5TMR | 0166 | Input Capture 5 Timer Value Register | | | | | | | | | | | | | | | | |
| IC6CON1 | 0168 | — | — | ICSIDL | ICTSEL2 | ICTSEL1 | ICTSELO | — | — | — | IC11 | IC10 | ICOV | ICBNE | ICM2 | ICM1 | ICM0 | 0000 |
| IC6CON2 | 016A | — | — | — | — | — | — | — | IC32 | ICTRIG | TRIGSTAT | — | SYNCSEL4 | SYNCSEL3 | SYNCSEL2 | SYNCSEL1 | SYNCSELO | 0000 |
| IC6BUF | 016C | Input Capture 6 Buffer Register | | | | | | | | | | | | | | | | |
| IC6TMR | 016E | Input Capture 6 Timer Value Register | | | | | | | | | | | | | | | | |
| IC7CON1 | 0170 | — | — | ICSIDL | ICTSEL2 | ICTSEL1 | ICTSELO | — | — | — | IC11 | IC10 | ICOV | ICBNE | ICM2 | ICM1 | ICM0 | 0000 |
| IC7CON2 | 0172 | — | — | — | — | — | — | — | IC32 | ICTRIG | TRIGSTAT | — | SYNCSEL4 | SYNCSEL3 | SYNCSEL2 | SYNCSEL1 | SYNCSELO | 0000 |
| IC7BUF | 0174 | Input Capture 7 Buffer Register | | | | | | | | | | | | | | | | |
| IC7TMR | 0176 | Input Capture 7 Timer Value Register | | | | | | | | | | | | | | | | |
| IC8CON1 | 0178 | — | — | ICSIDL | ICTSEL2 | ICTSEL1 | ICTSELO | — | — | — | IC11 | IC10 | ICOV | ICBNE | ICM2 | ICM1 | ICM0 | 0000 |
| IC8CON2 | 017A | — | — | — | — | — | — | — | IC32 | ICTRIG | TRIGSTAT | — | SYNCSEL4 | SYNCSEL3 | SYNCSEL2 | SYNCSEL1 | SYNCSELO | 0000 |
| IC8BUF | 017C | Input Capture 8 Buffer Register | | | | | | | | | | | | | | | | |
| IC8TMR | 017E | Input Capture 8 Timer Value Register | | | | | | | | | | | | | | | | |
| IC9CON1 | 0180 | — | — | ICSIDL | ICTSEL2 | ICTSEL1 | ICTSELO | — | — | — | IC11 | IC10 | ICOV | ICBNE | ICM2 | ICM1 | ICM0 | 0000 |
| IC9CON2 | 0182 | — | — | — | — | — | — | — | IC32 | ICTRIG | TRIGSTAT | — | SYNCSEL4 | SYNCSEL3 | SYNCSEL2 | SYNCSEL1 | SYNCSELO | 0000 |
| IC9BUF | 0184 | Input Capture 9 Buffer Register | | | | | | | | | | | | | | | | |
| IC9TMR | 0186 | Input Capture 9 Timer Value Register | | | | | | | | | | | | | | | | |

Legend: — = unimplemented, read as '0'. Reset values are shown in hexadecimal.

TABLE 4-9: OUTPUT COMPARE REGISTER MAP

| File Name | Addr | Bit 15 | Bit 14 | Bit 13 | Bit 12 | Bit 11 | Bit 10 | Bit 9 | Bit 8 | Bit 7 | Bit 6 | Bit 5 | Bit 4 | Bit 3 | Bit 2 | Bit 1 | Bit 0 | All Resets |
|-----------|------|---------------------------------------|--------|----------|---------|---------|---------|--------|--------|--------|----------|--------|----------|----------|----------|----------|----------|------------|
| OC1CON1 | 0190 | — | — | OCSIDL | OCTSEL2 | OCTSEL1 | OCTSEL0 | ENFLT2 | ENFLT1 | ENFLT0 | OCFLT2 | OCFLT1 | OCFLT0 | TRIGMODE | OCM2 | OCM1 | OCM0 | 0000 |
| OC1CON2 | 0192 | FLTMD | FLTOUT | FLTTRIEN | OCINV | — | DCB1 | DCB0 | OC32 | OCTRIG | TRIGSTAT | OCTRS | SYNCSEL4 | SYNCSEL3 | SYNCSEL2 | SYNCSEL1 | SYNCSEL0 | 000C |
| OC1RS | 0194 | Output Compare 1 Secondary Register | | | | | | | | | | | | | | | | |
| OC1R | 0196 | Output Compare 1 Register | | | | | | | | | | | | | | | | |
| OC1TMR | 0198 | Output Compare 1 Timer Value Register | | | | | | | | | | | | | | | | |
| OC2CON1 | 019A | — | — | OCSIDL | OCTSEL2 | OCTSEL1 | OCTSEL0 | ENFLT2 | ENFLT1 | ENFLT0 | OCFLT2 | OCFLT1 | OCFLT0 | TRIGMODE | OCM2 | OCM1 | OCM0 | 0000 |
| OC2CON2 | 019C | FLTMD | FLTOUT | FLTTRIEN | OCINV | — | DCB1 | DCB0 | OC32 | OCTRIG | TRIGSTAT | OCTRS | SYNCSEL4 | SYNCSEL3 | SYNCSEL2 | SYNCSEL1 | SYNCSEL0 | 000C |
| OC2RS | 019E | Output Compare 2 Secondary Register | | | | | | | | | | | | | | | | |
| OC2R | 01A0 | Output Compare 2 Register | | | | | | | | | | | | | | | | |
| OC2TMR | 01A2 | Output Compare 2 Timer Value Register | | | | | | | | | | | | | | | | |
| OC3CON1 | 01A4 | — | — | OCSIDL | OCTSEL2 | OCTSEL1 | OCTSEL0 | ENFLT2 | ENFLT1 | ENFLT0 | OCFLT2 | OCFLT1 | OCFLT0 | TRIGMODE | OCM2 | OCM1 | OCM0 | 0000 |
| OC3CON2 | 01A6 | FLTMD | FLTOUT | FLTTRIEN | OCINV | — | DCB1 | DCB0 | OC32 | OCTRIG | TRIGSTAT | OCTRS | SYNCSEL4 | SYNCSEL3 | SYNCSEL2 | SYNCSEL1 | SYNCSEL0 | 000C |
| OC3RS | 01A8 | Output Compare 3 Secondary Register | | | | | | | | | | | | | | | | |
| OC3R | 01AA | Output Compare 3 Register | | | | | | | | | | | | | | | | |
| OC3TMR | 01AC | Output Compare 3 Timer Value Register | | | | | | | | | | | | | | | | |
| OC4CON1 | 01AE | — | — | OCSIDL | OCTSEL2 | OCTSEL1 | OCTSEL0 | ENFLT2 | ENFLT1 | ENFLT0 | OCFLT2 | OCFLT1 | OCFLT0 | TRIGMODE | OCM2 | OCM1 | OCM0 | 0000 |
| OC4CON2 | 01B0 | FLTMD | FLTOUT | FLTTRIEN | OCINV | — | DCB1 | DCB0 | OC32 | OCTRIG | TRIGSTAT | OCTRS | SYNCSEL4 | SYNCSEL3 | SYNCSEL2 | SYNCSEL1 | SYNCSEL0 | 000C |
| OC4RS | 01B2 | Output Compare 4 Secondary Register | | | | | | | | | | | | | | | | |
| OC4R | 01B4 | Output Compare 4 Register | | | | | | | | | | | | | | | | |
| OC4TMR | 01B6 | Output Compare 4 Timer Value Register | | | | | | | | | | | | | | | | |
| OC5CON1 | 01B8 | — | — | OCSIDL | OCTSEL2 | OCTSEL1 | OCTSEL0 | ENFLT2 | ENFLT1 | ENFLT0 | OCFLT2 | OCFLT1 | OCFLT0 | TRIGMODE | OCM2 | OCM1 | OCM0 | 0000 |
| OC5CON2 | 01BA | FLTMD | FLTOUT | FLTTRIEN | OCINV | — | DCB1 | DCB0 | OC32 | OCTRIG | TRIGSTAT | OCTRS | SYNCSEL4 | SYNCSEL3 | SYNCSEL2 | SYNCSEL1 | SYNCSEL0 | 000C |
| OC5RS | 01BC | Output Compare 5 Secondary Register | | | | | | | | | | | | | | | | |
| OC5R | 01BE | Output Compare 5 Register | | | | | | | | | | | | | | | | |
| OC5TMR | 01C0 | Output Compare 5 Timer Value Register | | | | | | | | | | | | | | | | |
| OC6CON1 | 01C2 | — | — | OCSIDL | OCTSEL2 | OCTSEL1 | OCTSEL0 | ENFLT2 | ENFLT1 | ENFLT0 | OCFLT2 | OCFLT1 | OCFLT0 | TRIGMODE | OCM2 | OCM1 | OCM0 | 0000 |
| OC6CON2 | 01C4 | FLTMD | FLTOUT | FLTTRIEN | OCINV | — | DCB1 | DCB0 | OC32 | OCTRIG | TRIGSTAT | OCTRS | SYNCSEL4 | SYNCSEL3 | SYNCSEL2 | SYNCSEL1 | SYNCSEL0 | 000C |
| OC6RS | 01C6 | Output Compare 6 Secondary Register | | | | | | | | | | | | | | | | |
| OC6R | 01C8 | Output Compare 6 Register | | | | | | | | | | | | | | | | |
| OC6TMR | 01CA | Output Compare 6 Timer Value Register | | | | | | | | | | | | | | | | |
| OC7CON1 | 01CC | — | — | OCSIDL | OCTSEL2 | OCTSEL1 | OCTSEL0 | ENFLT2 | ENFLT1 | ENFLT0 | OCFLT2 | OCFLT1 | OCFLT0 | TRIGMODE | OCM2 | OCM1 | OCM0 | 0000 |
| OC7CON2 | 01CE | FLTMD | FLTOUT | FLTTRIEN | OCINV | — | DCB1 | DCB0 | OC32 | OCTRIG | TRIGSTAT | OCTRS | SYNCSEL4 | SYNCSEL3 | SYNCSEL2 | SYNCSEL1 | SYNCSEL0 | 000C |
| OC7RS | 01D0 | Output Compare 7 Secondary Register | | | | | | | | | | | | | | | | |
| OC7R | 01D2 | Output Compare 7 Register | | | | | | | | | | | | | | | | |
| OC7TMR | 01D4 | Output Compare 7 Timer Value Register | | | | | | | | | | | | | | | | |

Legend: — = unimplemented, read as '0'. Reset values are shown in hexadecimal.

PIC24FJ256DA210 FAMILY

查询PIC24FJ256DA106供应商

TABLE 4-9: OUTPUT COMPARE REGISTER MAP (CONTINUED)

| File Name | Addr | Bit 15 | Bit 14 | Bit 13 | Bit 12 | Bit 11 | Bit 10 | Bit 9 | Bit 8 | Bit 7 | Bit 6 | Bit 5 | Bit 4 | Bit 3 | Bit 2 | Bit 1 | Bit 0 | All Resets |
|-----------|------|---------------------------------------|--------|-----------|---------|---------|---------|--------|--------|--------|----------|--------|----------|----------|----------|----------|----------|------------|
| OC8CON1 | 01D6 | — | — | OC SIDL | OCTSEL2 | OCTSEL1 | OCTSEL0 | ENFLT2 | ENFLT1 | ENFLT0 | OCFLT2 | OCFLT1 | OCFLT0 | TRIGMODE | OCM2 | OCM1 | OCM0 | 0000 |
| OC8CON2 | 01D8 | FLTMD | FLTOUT | FLTTRIEEN | OCINV | — | DCB1 | DCB0 | OC32 | OCTRIG | TRIGSTAT | OCTRS | SYNCSEL4 | SYNCSEL3 | SYNCSEL2 | SYNCSEL1 | SYNCSEL0 | 000C |
| OC8RS | 01DA | Output Compare 8 Secondary Register | | | | | | | | | | | | | | | | |
| OC8R | 01DC | Output Compare 8 Register | | | | | | | | | | | | | | | | |
| OC8TMR | 01DE | Output Compare 8 Timer Value Register | | | | | | | | | | | | | | | | |
| OC9CON1 | 01E0 | — | — | OC SIDL | OCTSEL2 | OCTSEL1 | OCTSEL0 | ENFLT2 | ENFLT1 | ENFLT0 | OCFLT2 | OCFLT1 | OCFLT0 | TRIGMODE | OCM2 | OCM1 | OCM0 | 0000 |
| OC9CON2 | 01E2 | FLTMD | FLTOUT | FLTTRIEEN | OCINV | — | DCB1 | DCB0 | OC32 | OCTRIG | TRIGSTAT | OCTRS | SYNCSEL4 | SYNCSEL3 | SYNCSEL2 | SYNCSEL1 | SYNCSEL0 | 000C |
| OC9RS | 01E4 | Output Compare 9 Secondary Register | | | | | | | | | | | | | | | | |
| OC9R | 01E6 | Output Compare 9 Register | | | | | | | | | | | | | | | | |
| OC9TMR | 01E8 | Output Compare 9 Timer Value Register | | | | | | | | | | | | | | | | |

Legend: — = unimplemented, read as '0'. Reset values are shown in hexadecimal.

TABLE 4-10: I²C™ REGISTER MAP

| File Name | Addr | Bit 15 | Bit 14 | Bit 13 | Bit 12 | Bit 11 | Bit 10 | Bit 9 | Bit 8 | Bit 7 | Bit 6 | Bit 5 | Bit 4 | Bit 3 | Bit 2 | Bit 1 | Bit 0 | All Resets |
|-----------|------|---------|--------|---------|--------|--------|--------|--------|-------|-------|-------|-------------|-------|-------|-------------|-------|-------|------------|
| I2C1RCV | 0200 | — | — | — | — | — | — | — | — | — | — | — | — | — | — | — | — | 0000 |
| I2C1TRN | 0202 | — | — | — | — | — | — | — | — | — | — | — | — | — | — | — | — | 00FF |
| I2C1BRG | 0204 | — | — | — | — | — | — | — | — | — | — | — | — | — | — | — | — | 0000 |
| I2C1CON | 0206 | I2CEN | — | I2CSIDL | SCLREL | IPMIEN | A10M | DISSLW | SMEN | GCEN | STREN | ACKDT | ACKEN | RCEN | PEN | RSEN | SEN | 1000 |
| I2C1STAT | 0208 | ACKSTAT | TRSTAT | — | — | — | BCL | GCSTAT | ADD10 | IWCOL | I2COV | D \bar{A} | P | S | R \bar{W} | RBF | TBF | 0000 |
| I2C1ADD | 020A | — | — | — | — | — | — | — | — | — | — | — | — | — | — | — | — | 0000 |
| I2C1MSK | 020C | — | — | — | — | — | — | — | — | — | — | — | — | — | — | — | — | 0000 |
| I2C2RCV | 0210 | — | — | — | — | — | — | — | — | — | — | — | — | — | — | — | — | 0000 |
| I2C2TRN | 0212 | — | — | — | — | — | — | — | — | — | — | — | — | — | — | — | — | 00FF |
| I2C2BRG | 0214 | — | — | — | — | — | — | — | — | — | — | — | — | — | — | — | — | 0000 |
| I2C2CON | 0216 | I2CEN | — | I2CSIDL | SCLREL | IPMIEN | A10M | DISSLW | SMEN | GCEN | STREN | ACKDT | ACKEN | RCEN | PEN | RSEN | SEN | 1000 |
| I2C2STAT | 0218 | ACKSTAT | TRSTAT | — | — | — | BCL | GCSTAT | ADD10 | IWCOL | I2COV | D \bar{A} | P | S | R \bar{W} | RBF | TBF | 0000 |
| I2C2ADD | 021A | — | — | — | — | — | — | — | — | — | — | — | — | — | — | — | — | 0000 |
| I2C2MSK | 021C | — | — | — | — | — | — | — | — | — | — | — | — | — | — | — | — | 0000 |
| I2C3RCV | 0270 | — | — | — | — | — | — | — | — | — | — | — | — | — | — | — | — | 0000 |
| I2C3TRN | 0272 | — | — | — | — | — | — | — | — | — | — | — | — | — | — | — | — | 0000 |
| I2C3BRG | 0274 | — | — | — | — | — | — | — | — | — | — | — | — | — | — | — | — | 00FF |
| I2C3CON | 0276 | I2CEN | — | I2CSIDL | SCLREL | IPMIEN | A10M | DISSLW | SMEN | GCEN | STREN | ACKDT | ACKEN | RCEN | PEN | RSEN | SEN | 1000 |
| I2C3STAT | 0278 | ACKSTAT | TRSTAT | — | — | — | BCL | GCSTAT | ADD10 | IWCOL | I2COV | D \bar{A} | P | S | R \bar{W} | RBF | TBF | 0000 |
| I2C3ADD | 027A | — | — | — | — | — | — | — | — | — | — | — | — | — | — | — | — | 0000 |
| I2C3MSK | 027C | — | — | — | — | — | — | — | — | — | — | — | — | — | — | — | — | 0000 |

Legend: — = unimplemented, read as '0'. Reset values are shown in hexadecimal.

TABLE 4-11: UART REGISTER MAPS

| File Name | Addr | Bit 15 | Bit 14 | Bit 13 | Bit 12 | Bit 11 | Bit 10 | Bit 9 | Bit 8 | Bit 7 | Bit 6 | Bit 5 | Bit 4 | Bit 3 | Bit 2 | Bit 1 | Bit 0 | All Resets |
|-----------|------|----------|--------|----------|--------|--------|--------|-------|-------|----------|----------|-------|-------|-------|--------|-------|-------|------------|
| U1MODE | 0220 | UARTEN | — | USIDL | IREN | RTSMID | — | UEN1 | UEN0 | WAKE | LPBACK | ABAUD | RXINV | BRGH | PDSEL0 | STSEL | 0000 | |
| U1STA | 0222 | UTXISEL1 | UTXINV | UTXISEL0 | — | UTXBRK | UTXEN | UTXBF | TRMT | URXISEL1 | URXISEL0 | ADDEN | RIDLE | PERR | OERR | URXDA | 0110 | |
| U1TXREG | 0224 | — | — | — | — | — | — | — | — | — | — | — | — | — | — | — | xxxx | |
| U1RXREG | 0226 | — | — | — | — | — | — | — | — | — | — | — | — | — | — | — | 0000 | |
| U1BRG | 0228 | — | — | — | — | — | — | — | — | — | — | — | — | — | — | — | 0000 | |
| U2MODE | 0230 | UARTEN | — | USIDL | IREN | RTSMID | — | UEN1 | UEN0 | WAKE | LPBACK | ABAUD | RXINV | BRGH | PDSEL0 | STSEL | 0000 | |
| U2STA | 0232 | UTXISEL1 | UTXINV | UTXISEL0 | — | UTXBRK | UTXEN | UTXBF | TRMT | URXISEL1 | URXISEL0 | ADDEN | RIDLE | PERR | OERR | URXDA | 0110 | |
| U2TXREG | 0234 | — | — | — | — | — | — | — | — | — | — | — | — | — | — | — | xxxx | |
| U2RXREG | 0236 | — | — | — | — | — | — | — | — | — | — | — | — | — | — | — | 0000 | |
| U2BRG | 0238 | — | — | — | — | — | — | — | — | — | — | — | — | — | — | — | 0000 | |
| U3MODE | 0250 | UARTEN | — | USIDL | IREN | RTSMID | — | UEN1 | UEN0 | WAKE | LPBACK | ABAUD | RXINV | BRGH | PDSEL0 | STSEL | 0000 | |
| U3STA | 0252 | UTXISEL1 | UTXINV | UTXISEL0 | — | UTXBRK | UTXEN | UTXBF | TRMT | URXISEL1 | URXISEL0 | ADDEN | RIDLE | PERR | OERR | URXDA | 0110 | |
| U3TXREG | 0254 | — | — | — | — | — | — | — | — | — | — | — | — | — | — | — | xxxx | |
| U3RXREG | 0256 | — | — | — | — | — | — | — | — | — | — | — | — | — | — | — | 0000 | |
| U3BRG | 0258 | — | — | — | — | — | — | — | — | — | — | — | — | — | — | — | 0000 | |
| U4MODE | 02B0 | UARTEN | — | USIDL | IREN | RTSMID | — | UEN1 | UEN0 | WAKE | LPBACK | ABAUD | RXINV | BRGH | PDSEL0 | STSEL | 0000 | |
| U4STA | 02B2 | UTXISEL1 | UTXINV | UTXISEL0 | — | UTXBRK | UTXEN | UTXBF | TRMT | URXISEL1 | URXISEL0 | ADDEN | RIDLE | PERR | OERR | URXDA | 0110 | |
| U4TXREG | 02B4 | — | — | — | — | — | — | — | — | — | — | — | — | — | — | — | xxxx | |
| U4RXREG | 02B6 | — | — | — | — | — | — | — | — | — | — | — | — | — | — | — | 0000 | |
| U4BRG | 02B8 | — | — | — | — | — | — | — | — | — | — | — | — | — | — | — | 0000 | |

Legend: — = unimplemented, read as '0'. Reset values are shown in hexadecimal.

PIC24FJ256DA210 FAMILY

查询PIC24FJ256DA106供应商

TABLE 4-12: SPI REGISTER MAPS

| File Name | Addr | Bit 15 | Bit 14 | Bit 13 | Bit 12 | Bit 11 | Bit 10 | Bit 9 | Bit 8 | Bit 7 | Bit 6 | Bit 5 | Bit 4 | Bit 3 | Bit 2 | Bit 1 | Bit 0 | All Resets |
|----------------------------------|------|--------|--------|---------|--------|---------|---------|---------|-------|--------|--------|--------|--------|--------|--------|--------|--------|------------|
| SPI1 Transmit and Receive Buffer | | | | | | | | | | | | | | | | | | |
| SP11STAT | 0240 | SPIEN | — | SPIIDL | — | SPIBEC2 | SPIBEC1 | SPIBEC0 | SRMPT | SPIROV | SRXMPT | SRXMPT | SISEL2 | SISEL1 | SISEL0 | SPI7BF | SPIRBF | 0000 |
| SP11CON1 | 0242 | — | — | — | DISSCK | MODE16 | SMP | CKE | SSEN | — | CKP | MSTEN | SPRE2 | SPRE1 | SPRE0 | PPRE1 | PPRE0 | 0000 |
| SP11CON2 | 0244 | FRMEN | SPIFSD | SPIFPOL | — | — | — | — | — | — | — | — | — | — | — | SPIFE | SPIBEN | 0000 |
| SP11BUF | 0248 | | | | | | | | | | | | | | | | | |
| SPI2 Transmit and Receive Buffer | | | | | | | | | | | | | | | | | | |
| SP12STAT | 0260 | SPIEN | — | SPIIDL | — | SPIBEC2 | SPIBEC1 | SPIBEC0 | SRMPT | SPIROV | SRXMPT | SRXMPT | SISEL2 | SISEL1 | SISEL0 | SPI7BF | SPIRBF | 0000 |
| SP12CON1 | 0262 | — | — | — | DISSCK | MODE16 | SMP | CKE | SSEN | — | CKP | MSTEN | SPRE2 | SPRE1 | SPRE0 | PPRE1 | PPRE0 | 0000 |
| SP12CON2 | 0264 | FRMEN | SPIFSD | SPIFPOL | — | — | — | — | — | — | — | — | — | — | — | SPIFE | SPIBEN | 0000 |
| SP12BUF | 0268 | | | | | | | | | | | | | | | | | |
| SPI3 Transmit and Receive Buffer | | | | | | | | | | | | | | | | | | |
| SP13STAT | 0280 | SPIEN | — | SPIIDL | — | SPIBEC2 | SPIBEC1 | SPIBEC0 | SRMPT | SPIROV | SRXMPT | SRXMPT | SISEL2 | SISEL1 | SISEL0 | SPI7BF | SPIRBF | 0000 |
| SP13CON1 | 0282 | — | — | — | DISSCK | MODE16 | SMP | CKE | SSEN | — | CKP | MSTEN | SPRE2 | SPRE1 | SPRE0 | PPRE1 | PPRE0 | 0000 |
| SP13CON2 | 0284 | FRMEN | SPIFSD | SPIFPOL | — | — | — | — | — | — | — | — | — | — | — | SPIFE | SPIBEN | 0000 |
| SP13BUF | 0288 | | | | | | | | | | | | | | | | | |

Legend: — = unimplemented, read as '0'. Reset values are shown in hexadecimal.

TABLE 4-13: PORTA REGISTER MAP(1)

| File Name | Addr | Bit 15 | Bit 14 | Bit 13 | Bit 12 | Bit 11 | Bit 10 | Bit 9 | Bit 8 | Bit 7 | Bit 6 | Bit 5 | Bit 4 | Bit 3 | Bit 2 | Bit 1 | Bit 0 | All Resets |
|-----------|------|---------|---------|--------|--------|--------|---------|--------|-------|--------|--------|--------|--------|--------|--------|--------|--------|------------|
| TRISA | 02C0 | TRISA15 | TRISA14 | — | — | — | TRISA10 | TRISA9 | — | TRISA7 | TRISA6 | TRISA5 | TRISA4 | TRISA3 | TRISA2 | TRISA1 | TRISA0 | C6FF |
| PORTA | 02C2 | RA15 | RA14 | — | — | — | RA10 | RA9 | — | RA7 | RA6 | RA5 | RA4 | RA3 | RA2 | RA1 | RA0 | xxxx |
| LATA | 02C4 | LATA15 | LATA14 | — | — | — | LATA10 | LATA9 | — | LATA7 | LATA6 | LATA5 | LATA4 | LATA3 | LATA2 | LATA1 | LATA0 | xxxx |
| ODCA | 02C6 | ODA15 | ODA14 | — | — | — | ODA10 | ODA9 | — | ODA7 | ODA6 | ODA5 | ODA4 | ODA3 | ODA2 | ODA1 | ODA0 | 0000 |

Legend: — = unimplemented, read as '0'. Reset values are shown in hexadecimal. Reset values shown are for 100-pin devices.

Note 1: PORTA and all associated bits are unimplemented on 64-pin devices and read as '0'. Bits are available on 100-pin devices only, unless otherwise noted.

TABLE 4-14: PORTB REGISTER MAP

| File Name | Addr | Bit 15 | Bit 14 | Bit 13 | Bit 12 | Bit 11 | Bit 10 | Bit 9 | Bit 8 | Bit 7 | Bit 6 | Bit 5 | Bit 4 | Bit 3 | Bit 2 | Bit 1 | Bit 0 | All Resets |
|-----------|------|---------|---------|---------|---------|---------|---------|--------|--------|--------|--------|--------|--------|--------|--------|--------|--------|------------|
| TRISB | 02C8 | TRISB15 | TRISB14 | TRISB13 | TRISB12 | TRISB11 | TRISB10 | TRISB9 | TRISB8 | TRISB7 | TRISB6 | TRISB5 | TRISB4 | TRISB3 | TRISB2 | TRISB1 | TRISB0 | FFFF |
| PORTB | 02CA | RB15 | RB14 | RB13 | RB12 | RB11 | RB10 | RB9 | RB8 | RB7 | RB6 | RB5 | RB4 | RB3 | RB2 | RB1 | RB0 | xxxx |
| LATB | 02CC | LATB15 | LATB14 | LATB13 | LATB12 | LATB11 | LATB10 | LATB9 | LATB8 | LATB7 | LATB6 | LATB5 | LATB4 | LATB3 | LATB2 | LATB1 | LATB0 | xxxx |
| ODCB | 02CE | ODB15 | ODB14 | ODB13 | ODB12 | ODB11 | ODB10 | ODB9 | ODB8 | ODB7 | ODB6 | ODB5 | ODB4 | ODB3 | ODB2 | ODB1 | ODB0 | 0000 |

Legend: — = unimplemented, read as '0'. Reset values are shown in hexadecimal.

TABLE 4-15: PORTC REGISTER MAP

| File Name | Addr | Bit 15 | Bit 14 | Bit 13 | Bit 12 | Bit 11 | Bit 10 | Bit 9 | Bit 8 | Bit 7 | Bit 6 | Bit 5 | Bit 4 ⁽¹⁾ | Bit 3 ⁽¹⁾ | Bit 2 ⁽¹⁾ | Bit 1 ⁽¹⁾ | Bit 0 | All Resets |
|-----------|------|-----------------------|---------|---------|---------------------|--------|--------|-------|-------|-------|-------|-------|----------------------|----------------------|----------------------|----------------------|-------|------------|
| TRISC | 02D0 | TRISC15 | TRISC14 | TRISC13 | TRISC12 | — | — | — | — | — | — | — | TRISC4 | TRISC3 | TRISC2 | TRISC1 | — | F01E |
| PORTC | 02D2 | RC15 ^(2,3) | RC14 | RC13 | RC12 ⁽²⁾ | — | — | — | — | — | — | — | RC4 | RC3 | RC2 | RC1 | — | xxxxx |
| LATC | 02D4 | LATC15 | LATC14 | LATC13 | LATC12 | — | — | — | — | — | — | — | LATC4 | LATC3 | LATC2 | LATC1 | — | xxxxx |
| ODCC | 02D6 | ODC15 | ODC14 | ODC13 | ODC12 | — | — | — | — | — | — | — | ODC4 | ODC3 | ODC2 | ODC1 | — | 0000 |

Legend: — = unimplemented, read as '0'. Reset values are shown in hexadecimal. Reset values shown are for 100-pin devices.

Note 1: Bits are unimplemented in 64-pin devices; read as '0'.

2: RC12 and RC15 are only available when the primary oscillator is disabled or when EC mode is selected (POSCMD<1:0> Configuration bits = 11 or 00); otherwise read as '0'.

3: RC15 is only available when the POSCMD<1:0> Configuration bits = 11 or 00 and the OSCIOFN Configuration bit = 1.

TABLE 4-16: PORTD REGISTER MAP

| File Name | Addr | Bit 15 ⁽¹⁾ | Bit 14 ⁽¹⁾ | Bit 13 ⁽¹⁾ | Bit 12 ⁽¹⁾ | Bit 11 | Bit 10 | Bit 9 | Bit 8 | Bit 7 | Bit 6 | Bit 5 | Bit 4 | Bit 3 | Bit 2 | Bit 1 | Bit 0 | All Resets |
|-----------|------|-----------------------|-----------------------|-----------------------|-----------------------|---------|---------|--------|--------|--------|--------|--------|--------|--------|--------|--------|--------|------------|
| TRISD | 02D8 | TRISD15 | TRISD14 | TRISD13 | TRISD12 | TRISD11 | TRISD10 | TRISD9 | TRISD8 | TRISD7 | TRISD6 | TRISD5 | TRISD4 | TRISD3 | TRISD2 | TRISD1 | TRISD0 | FFFF |
| PORTD | 02DA | RD15 | RD14 | RD13 | RD12 | RD11 | RD10 | RD9 | RD8 | RD7 | RD6 | RD5 | RD4 | RD3 | RD2 | RD1 | RD0 | xxxxx |
| LATD | 02DC | LATD15 | LATD14 | LATD13 | LATD12 | LATD11 | LATD10 | LATD9 | LATD8 | LATD7 | LATD6 | LATD5 | LATD4 | LATD3 | LATD2 | LATD1 | LATD0 | xxxxx |
| ODDD | 02DE | ODD15 | ODD14 | ODD13 | ODD12 | ODD11 | ODD10 | ODD9 | ODD8 | ODD7 | ODD6 | ODD5 | ODD4 | ODD3 | ODD2 | ODD1 | ODD0 | 0000 |

Legend: — = unimplemented, read as '0'. Reset values are shown in hexadecimal. Reset values shown are for 100-pin devices.

Note 1: Bits are unimplemented in 64-pin devices; read as '0'.

TABLE 4-17: PORTE REGISTER MAP

| File Name | Addr | Bit 15 | Bit 14 | Bit 13 | Bit 12 | Bit 11 | Bit 10 | Bit 9 ⁽¹⁾ | Bit 8 ⁽¹⁾ | Bit 7 | Bit 6 | Bit 5 | Bit 4 | Bit 3 | Bit 2 | Bit 1 | Bit 0 | All Resets |
|-----------|------|--------|--------|--------|--------|--------|--------|----------------------|----------------------|--------|--------|--------|--------|--------|--------|--------|--------|------------|
| TRISE | 02E0 | — | — | — | — | — | — | TRISE9 | TRISE8 | TRISE7 | TRISE6 | TRISE5 | TRISE4 | TRISE3 | TRISE2 | TRISE1 | TRISE0 | 03FF |
| PORTE | 02E2 | — | — | — | — | — | — | RE9 | RE8 | RE7 | RE6 | RE5 | RE4 | RE3 | RE2 | RE1 | RE0 | xxxxx |
| LATE | 02E4 | — | — | — | — | — | — | LATE9 | LATE8 | LATE7 | LATE6 | LATE5 | LATE4 | LATE3 | LATE2 | LATE1 | LATE0 | xxxxx |
| ODEE | 02E6 | — | — | — | — | — | — | ODE9 | ODE8 | ODE7 | ODE6 | ODE5 | ODE4 | ODE3 | ODE2 | ODE1 | ODE0 | 0000 |

Legend: — = unimplemented, read as '0'. Reset values are shown in hexadecimal. Reset values shown are for 100-pin devices.

Note 1: Bits are unimplemented in 64-pin devices; read as '0'.

PIC24FJ256DA210 FAMILY

查询PIC24FJ256DA106供应商

TABLE 4-18: PORTF REGISTER MAP

| File Name | Addr | Bit 15 | Bit 14 | Bit 13 ⁽¹⁾ | Bit 12 ⁽¹⁾ | Bit 11 | Bit 10 | Bit 9 | Bit 8 ⁽¹⁾ | Bit 7 | Bit 6 | Bit 5 | Bit 4 | Bit 3 | Bit 2 ⁽¹⁾ | Bit 1 | Bit 0 | All Resets |
|-----------|------|--------|--------|-----------------------|-----------------------|--------|--------|-------|----------------------|--------|-------|--------|--------|--------|----------------------|--------|--------|------------|
| TRISF | 02E8 | — | — | TRISF13 | TRISF12 | — | — | — | TRISF8 | TRISF7 | — | TRISF5 | TRISF4 | TRISF3 | TRISF2 | TRISF1 | TRISF0 | 3.LBF |
| PORTF | 02EA | — | — | RF13 | RF12 | — | — | — | RF8 | RF7 | — | RF5 | RF4 | RF3 | RF2 | RF1 | RF0 | xxx-xx |
| LATF | 02EC | — | — | LATF13 | LATF12 | — | — | — | LATF8 | LATF7 | — | LATF5 | LATF4 | LATF3 | LATF2 | LATF1 | LATF0 | xxx-xx |
| ODCF | 02EE | — | — | ODF13 | ODF12 | — | — | — | ODF8 | ODF7 | — | ODF5 | ODF4 | ODF3 | ODF2 | ODF1 | ODF0 | 0000 |

Legend: — = unimplemented, read as '0'. Reset values are shown in hexadecimal. Reset values shown are for 100-pin devices.

Note 1: Bits are unimplemented in 64-pin devices; read as '0'.

TABLE 4-19: PORTG REGISTER MAP

| File Name | Addr | Bit 15 ⁽¹⁾ | Bit 14 ⁽¹⁾ | Bit 13 ⁽¹⁾ | Bit 12 ⁽¹⁾ | Bit 11 | Bit 10 | Bit 9 | Bit 8 | Bit 7 | Bit 6 | Bit 5 | Bit 4 | Bit 3 | Bit 2 | Bit 1 ⁽¹⁾ | Bit 0 ⁽¹⁾ | All Resets |
|-----------|------|-----------------------|-----------------------|-----------------------|-----------------------|--------|--------|--------|--------|--------|--------|-------|-------|--------|--------|----------------------|----------------------|------------|
| TRISG | 02F0 | TRISG15 | TRISG14 | TRISG13 | TRISG12 | — | — | TRISG9 | TRISG8 | TRISG7 | TRISG6 | — | — | TRISG3 | TRISG2 | TRISG1 | TRISG0 | F3.CF |
| PORTG | 02F2 | RG15 | RG14 | RG13 | RG12 | — | — | RG9 | RG8 | RG7 | RG6 | — | — | RG3 | RG2 | RG1 | RG0 | xxx-xx |
| LATG | 02F4 | LATG15 | LATG14 | LATG13 | LATG12 | — | — | LATG9 | LATG8 | LATG7 | LATG6 | — | — | LATG3 | LATG2 | LATG1 | LATG0 | xxx-xx |
| ODG | 02F6 | ODG15 | ODG14 | ODG13 | ODG12 | — | — | ODG9 | ODG8 | ODG7 | ODG6 | — | — | ODG3 | ODG2 | ODG1 | ODG0 | 0000 |

Legend: — = unimplemented, read as '0'. Reset values are shown in hexadecimal. Reset values shown are for 100-pin devices.

Note 1: Bits are unimplemented in 64-pin devices; read as '0'.

TABLE 4-20: PAD CONFIGURATION REGISTER MAP

| File Name | Addr | Bit 15 | Bit 14 | Bit 13 | Bit 12 | Bit 11 | Bit 10 | Bit 9 | Bit 8 | Bit 7 | Bit 6 | Bit 5 | Bit 4 | Bit 3 | Bit 2 | Bit 1 | Bit 0 | All Resets |
|-----------|------|--------|--------|--------|--------|--------|--------|-------|-------|-------|-------|-------|-------|-------|-------|----------|-----------------------|------------|
| PADCFG1 | 02FC | — | — | — | — | — | — | — | — | — | — | — | — | — | — | RTSECSEL | PMPTTL ⁽¹⁾ | 0000 |

Legend: — = unimplemented, read as '0'. Reset values are shown in hexadecimal.

Note 1: Bits are unimplemented in 64-pin devices; read as '0'.

PIC24FJ256DA210 FAMILY

[查询PIC24FJ256DA106供应商](#)

TABLE 4-21: ADC REGISTER MAP

| File Name | Addr | Bit 15 | Bit 14 | Bit 13 | Bit 12 | Bit 11 | Bit 10 | Bit 9 | Bit 8 | Bit 7 | Bit 6 | Bit 5 | Bit 4 | Bit 3 | Bit 2 | Bit 1 | Bit 0 | All Resets |
|-----------|------|--------|--------|--------|--------|--------|--------|-------|-------|-------|-------|-------|-------|-------|-------|-------|-------|------------|
| ADC1BUF0 | 0300 | | | | | | | | | | | | | | | | | xxxx |
| ADC1BUF1 | 0302 | | | | | | | | | | | | | | | | | xxxx |
| ADC1BUF2 | 0304 | | | | | | | | | | | | | | | | | xxxx |
| ADC1BUF3 | 0306 | | | | | | | | | | | | | | | | | xxxx |
| ADC1BUF4 | 0308 | | | | | | | | | | | | | | | | | xxxx |
| ADC1BUF5 | 030A | | | | | | | | | | | | | | | | | xxxx |
| ADC1BUF6 | 030C | | | | | | | | | | | | | | | | | xxxx |
| ADC1BUF7 | 030E | | | | | | | | | | | | | | | | | xxxx |
| ADC1BUF8 | 0310 | | | | | | | | | | | | | | | | | xxxx |
| ADC1BUF9 | 0312 | | | | | | | | | | | | | | | | | xxxx |
| ADC1BUFA | 0314 | | | | | | | | | | | | | | | | | xxxx |
| ADC1BUFB | 0316 | | | | | | | | | | | | | | | | | xxxx |
| ADC1BUFC | 0318 | | | | | | | | | | | | | | | | | xxxx |
| ADC1BUFD | 031A | | | | | | | | | | | | | | | | | xxxx |
| ADC1BUFE | 031C | | | | | | | | | | | | | | | | | xxxx |
| ADC1BUFF | 031E | | | | | | | | | | | | | | | | | xxxx |
| ADC1BUF10 | 0340 | | | | | | | | | | | | | | | | | xxxx |
| ADC1BUF11 | 0342 | | | | | | | | | | | | | | | | | xxxx |
| ADC1BUF12 | 0344 | | | | | | | | | | | | | | | | | xxxx |
| ADC1BUF13 | 0346 | | | | | | | | | | | | | | | | | xxxx |
| ADC1BUF14 | 0348 | | | | | | | | | | | | | | | | | xxxx |
| ADC1BUF15 | 034A | | | | | | | | | | | | | | | | | xxxx |
| ADC1BUF16 | 034C | | | | | | | | | | | | | | | | | xxxx |
| ADC1BUF17 | 034E | | | | | | | | | | | | | | | | | xxxx |
| ADC1BUF18 | 0350 | | | | | | | | | | | | | | | | | xxxx |
| ADC1BUF19 | 0352 | | | | | | | | | | | | | | | | | xxxx |
| ADC1BUF1A | 0354 | | | | | | | | | | | | | | | | | xxxx |
| ADC1BUF1B | 0356 | | | | | | | | | | | | | | | | | xxxx |
| ADC1BUF1C | 0358 | | | | | | | | | | | | | | | | | xxxx |
| ADC1BUF1D | 035A | | | | | | | | | | | | | | | | | xxxx |
| ADC1BUF1E | 035C | | | | | | | | | | | | | | | | | xxxx |
| ADC1BUF1F | 035E | | | | | | | | | | | | | | | | | xxxx |

Legend: — = unimplemented, read as '0'; r = reserved, maintain as '0'; Reset values are shown in hexadecimal.

Note 1: Unimplemented in 64-pin devices, read as '0'

PIC24FJ256DA210 FAMILY

[查询PIC24FJ256DA106供应商](#)

TABLE 4-21: ADC REGISTER MAP (CONTINUED)

| File Name | Addr | Bit 15 | Bit 14 | Bit 13 | Bit 12 | Bit 11 | Bit 10 | Bit 9 | Bit 8 | Bit 7 | Bit 6 | Bit 5 | Bit 4 | Bit 3 | Bit 2 | Bit 1 | Bit 0 | All Resets |
|-----------|------|--------|--------|--------|--------|--------|--------|--------|--------|-----------|-----------|-----------|-----------|-----------|-----------|-----------|-----------|------------|
| AD1CON1 | 0320 | ADON | — | ADSIDL | — | — | — | FORM1 | FORM0 | SSRC2 | SSRC1 | SSRC0 | — | — | ASAM | SAMP | DONE | 0000 |
| AD1CON2 | 0322 | VCFG2 | VCFG1 | VCFG0 | r | — | CSCNA | — | — | BUFS | SMP14 | SMP13 | SMP12 | SMP11 | SMP10 | BUFM | ALTS | 0000 |
| AD1CON3 | 0324 | ADRC | r | r | SAMC4 | SAMC3 | SAMC2 | SAMC1 | SAMC0 | ADCS7 | ADCS6 | ADCS5 | ADCS4 | ADCS3 | ADCS2 | ADCS1 | ADCS0 | 0000 |
| AD1CHS | 0328 | CH0NB | — | — | CH0SB4 | CH0SB3 | CH0SB2 | CH0SB1 | CH0SB0 | CH0NA | — | — | CH0SA4 | CH0SA3 | CH0SA2 | CH0SA1 | CH0SA0 | 0000 |
| AD1CSSH | 032E | — | — | — | — | CSSL27 | CSSL26 | CSSL25 | CSSL24 | CSSL23(1) | CSSL22(1) | CSSL21(1) | CSSL20(1) | CSSL19(1) | CSSL18(1) | CSSL17(1) | CSSL16(1) | 0000 |
| AD1CSSL | 0330 | CSSL15 | CSSL14 | CSSL13 | CSSL12 | CSSL11 | CSSL10 | CSSL9 | CSSL8 | CSSL7 | CSSL6 | CSSL5 | CSSL4 | CSSL3 | CSSL2 | CSSL1 | CSSL0 | 0000 |

Legend: — = unimplemented, read as '0', r = reserved, maintain as '0'. Reset values are shown in hexadecimal.

Note 1: Unimplemented in 64-pin devices, read as '0'.

TABLE 4-22: CTMU REGISTER MAP

| File Name | Addr | Bit 15 | Bit 14 | Bit 13 | Bit 12 | Bit 11 | Bit 10 | Bit 9 | Bit 8 | Bit 7 | Bit 6 | Bit 5 | Bit 4 | Bit 3 | Bit 2 | Bit 1 | Bit 0 | All Resets |
|-----------|------|--------|--------|----------|--------|--------|----------|---------|--------|---------|----------|----------|---------|----------|----------|----------|----------|------------|
| CTMUCON | 033C | CTMUEN | — | CTMUSIDL | TGEN | EDGEN | EDGSEQEN | IDISSEN | CTTRIG | EDG2POL | EDG3SEL1 | EDG2SELO | EDG1POL | EDG1SEL1 | EDG1SELO | EDG2STAT | EDG1STAT | 0000 |
| CTMUICON | 033E | ITRIM5 | ITRIM4 | ITRIM3 | ITRIM2 | ITRIM1 | ITRIM0 | IRNG1 | IRNG0 | — | — | — | — | — | — | — | — | 0000 |

Legend: — = unimplemented, read as '0'. Reset values are shown in hexadecimal.

PIC24FJ256DA210 FAMILY

查询PIC24FJ256DA106供应商

TABLE 4-23: USB OTG REGISTER MAP

| File Name | Addr | Bit 15 | Bit 14 | Bit 13 | Bit 12 | Bit 11 | Bit 10 | Bit 9 | Bit 8 | Bit 7 | Bit 6 | Bit 5 | Bit 4 | Bit 3 | Bit 2 | Bit 1 | Bit 0 | All Resets |
|--------------------------|---------------------|--------|--------|--------|--------|--------|--------|-------|-------|-----------------------|-------------------------|-----------|-----------|----------|----------|----------|-------------------------|------------|
| U1OTGIR ⁽²⁾ | 0480 | — | — | — | — | — | — | — | — | IDIF | TIMSECF | LSTATEIF | ACTVIF | SESVDF | SESENDIF | — | VBUSVDF | 0000 |
| U1OTGIE ⁽²⁾ | 0482 | — | — | — | — | — | — | — | — | IDIE | TIMSECIE | LSTATEIE | ACTVIE | SESVDF | SESENDIE | — | VBUSVDIE | 0000 |
| U1OTGSTAT ⁽²⁾ | 0484 | — | — | — | — | — | — | — | — | ID | — | LSTATE | — | SESVDF | SESEND | — | VBUSVD | 0000 |
| U1OTGCON ⁽²⁾ | 0486 | — | — | — | — | — | — | — | — | DPPULUP | DMPULUP | DPPULDOWN | DMPULDOWN | VBUSON | OTGEN | VBUSCHG | VBUSDIS | 0000 |
| U1PWRC | 0488 | — | — | — | — | — | — | — | — | UACTPND | — | — | USLPGRD | — | — | USUSPND | USBPWR | 0000 |
| U1IR | 048A ⁽¹⁾ | — | — | — | — | — | — | — | — | STALLIF | — | RESUMEIF | IDLEIF | TRNIF | SOFIF | UERRIF | URSTIF | 0000 |
| | | — | — | — | — | — | — | — | — | STALLIF | ATTACHIE ⁽¹⁾ | RESUMEIF | IDLEIF | TRNIF | SOFIF | UERRIF | DETACHIE ⁽¹⁾ | 0000 |
| U1IE | 048C ⁽¹⁾ | — | — | — | — | — | — | — | — | STALLIE | — | RESUMEIE | IDLEIE | TRNIE | SOFIE | UERRIE | URSTIE | 0000 |
| | | — | — | — | — | — | — | — | — | STALLIE | ATTACHIE ⁽¹⁾ | RESUMEIE | IDLEIE | TRNIE | SOFIE | UERRIE | DETACHIE ⁽¹⁾ | 0000 |
| U1EIR | 048E ⁽¹⁾ | — | — | — | — | — | — | — | — | BTSEF | — | DMAEF | BTOEF | DFN8EF | CRC16EF | CRC5EF | PIDEF | 0000 |
| | | — | — | — | — | — | — | — | — | BTSEF | — | DMAEF | BTOEF | DFN8EF | CRC16EF | CRC5EF | PIDEF | 0000 |
| U1EIE | 0490 ⁽¹⁾ | — | — | — | — | — | — | — | — | BTSEE | — | DMAEE | BTOEE | DFN8EE | CRC16EE | CRC5EE | PIDEE | 0000 |
| | | — | — | — | — | — | — | — | — | BTSEE | — | DMAEE | BTOEE | DFN8EE | CRC16EE | CRC5EE | PIDEE | 0000 |
| U1STAT | 0492 | — | — | — | — | — | — | — | — | ENDPT3 | ENDPT2 | ENDPT1 | ENDPT0 | DIR | PPBI | — | — | 0000 |
| U1CON | 0494 ⁽¹⁾ | — | — | — | — | — | — | — | — | JSTATE ⁽¹⁾ | SE0 | PKTDIS | — | HOSTEN | RESUME | PPBRST | USBEN | 0000 |
| | | — | — | — | — | — | — | — | — | JSTATE ⁽¹⁾ | SE0 | TOKBUSY | USBRST | HOSTEN | RESUME | PPBRST | SOFEN ⁽¹⁾ | 0000 |
| U1ADDR | 0496 | — | — | — | — | — | — | — | — | LSPDEN ⁽¹⁾ | — | — | — | — | — | — | — | 0000 |
| U1BDTP1 | 0498 | — | — | — | — | — | — | — | — | — | — | — | — | — | — | — | — | 0000 |
| U1FRML | 049A | — | — | — | — | — | — | — | — | — | — | — | — | — | — | — | — | 0000 |
| U1FRMH | 049C | — | — | — | — | — | — | — | — | — | — | — | — | — | — | — | — | 0000 |
| U1TOK ⁽²⁾ | 049E | — | — | — | — | — | — | — | — | PID3 | PID2 | PID1 | PID0 | EP3 | EP2 | EP1 | EP0 | 0000 |
| U1SOF ⁽²⁾ | 04A0 | — | — | — | — | — | — | — | — | — | — | — | — | — | — | — | — | 0000 |
| U1CNFG1 | 04A6 | — | — | — | — | — | — | — | — | UTEYE | UOEMON | — | USBSIDL | — | — | PPB1 | PRB0 | 0000 |
| U1CNFG2 | 04A8 | — | — | — | — | — | — | — | — | — | — | UVCMPSEL | PUIVBUS | EXTI2CEN | UVBUSDIS | UVCMPDIS | UTRDIS | 0000 |
| U1EP0 | 04AA | — | — | — | — | — | — | — | — | — | RETRYDIS ⁽¹⁾ | — | EPCONDIS | EPRXEN | EPTXEN | EPSTALL | EPHSHK | 0000 |
| U1EP1 | 04AC | — | — | — | — | — | — | — | — | — | — | — | EPCONDIS | EPRXEN | EPTXEN | EPSTALL | EPHSHK | 0000 |
| U1EP2 | 04AE | — | — | — | — | — | — | — | — | — | — | — | EPCONDIS | EPRXEN | EPTXEN | EPSTALL | EPHSHK | 0000 |
| U1EP3 | 04B0 | — | — | — | — | — | — | — | — | — | — | — | EPCONDIS | EPRXEN | EPTXEN | EPSTALL | EPHSHK | 0000 |
| U1EP4 | 04B2 | — | — | — | — | — | — | — | — | — | — | — | EPCONDIS | EPRXEN | EPTXEN | EPSTALL | EPHSHK | 0000 |
| U1EP5 | 04B4 | — | — | — | — | — | — | — | — | — | — | — | EPCONDIS | EPRXEN | EPTXEN | EPSTALL | EPHSHK | 0000 |
| U1EP6 | 04B6 | — | — | — | — | — | — | — | — | — | — | — | EPCONDIS | EPRXEN | EPTXEN | EPSTALL | EPHSHK | 0000 |
| U1EP7 | 04B8 | — | — | — | — | — | — | — | — | — | — | — | EPCONDIS | EPRXEN | EPTXEN | EPSTALL | EPHSHK | 0000 |
| U1EP8 | 04BA | — | — | — | — | — | — | — | — | — | — | — | EPCONDIS | EPRXEN | EPTXEN | EPSTALL | EPHSHK | 0000 |
| U1EP9 | 04BC | — | — | — | — | — | — | — | — | — | — | — | EPCONDIS | EPRXEN | EPTXEN | EPSTALL | EPHSHK | 0000 |

Legend: — = unimplemented, read as '0'. Reset values are shown in hexadecimal.
Note 1: Alternate register or bit definitions when the module is operating in Host mode.
Note 2: This register is available in Host mode only.

PIC24FJ256DA210 FAMILY

[查询PIC24FJ256DA106供应商](#)

TABLE 4-23: USB OTG REGISTER MAP (CONTINUED)

| File Name | Addr | Bit 15 | Bit 14 | Bit 13 | Bit 12 | Bit 11 | Bit 10 | Bit 9 | Bit 8 | Bit 7 | Bit 6 | Bit 5 | Bit 4 | Bit 3 | Bit 2 | Bit 1 | Bit 0 | All Resets |
|-----------|------|--|--------|--------|--------|--------|--------|--------|-------|-------|-------|-------|----------|--------|--------|---------|--------|------------|
| U1EP10 | 04BE | — | — | — | — | — | — | — | — | — | — | — | EPCONDIS | EPRXEN | EPTXEN | EPSTALL | EPHSHK | 0000 |
| U1EP11 | 04C0 | — | — | — | — | — | — | — | — | — | — | — | EPCONDIS | EPRXEN | EPTXEN | EPSTALL | EPHSHK | 0000 |
| U1EP12 | 04C2 | — | — | — | — | — | — | — | — | — | — | — | EPCONDIS | EPRXEN | EPTXEN | EPSTALL | EPHSHK | 0000 |
| U1EP13 | 04C4 | — | — | — | — | — | — | — | — | — | — | — | EPCONDIS | EPRXEN | EPTXEN | EPSTALL | EPHSHK | 0000 |
| U1EP14 | 04C6 | — | — | — | — | — | — | — | — | — | — | — | EPCONDIS | EPRXEN | EPTXEN | EPSTALL | EPHSHK | 0000 |
| U1EP15 | 04C8 | — | — | — | — | — | — | — | — | — | — | — | EPCONDIS | EPRXEN | EPTXEN | EPSTALL | EPHSHK | 0000 |
| U1PWWRRS | 04CC | USB Power Supply PWM Duty Cycle Register | | | | | | | | | | | | | | | | |
| U1PWWCON | 04CE | PWMEN | — | — | — | — | — | PWMPOL | CNTEN | — | — | — | — | — | — | — | — | 0000 |

Legend: — = unimplemented, read as '0'. Reset values are shown in hexadecimal.
Note 1: Alternate register or bit definitions when the module is operating in Host mode.
Note 2: This register is available in Host mode only.

TABLE 4-24: ANCFG REGISTER MAP

| File Name | Addr | Bit 15 | Bit 14 | Bit 13 | Bit 12 | Bit 11 | Bit 10 | Bit 9 | Bit 8 | Bit 7 | Bit 6 | Bit 5 | Bit 4 | Bit 3 | Bit 2 | Bit 1 | Bit 0 | All Resets |
|-----------|------|--------|--------|--------|--------|--------|--------|-------|-------|-------|-------|-------|-------|-------|-------|--------|-------|------------|
| ANCFG | 04DE | — | — | — | — | — | — | — | — | — | — | — | — | — | VBGEN | VBG2EN | VBGEN | 0000 |

Legend: — = unimplemented, read as '0'. Reset values are shown in hexadecimal.

TABLE 4-25: ANSEL REGISTER MAP

| File Name | Addr | Bit 15 | Bit 14 | Bit 13 | Bit 12 | Bit 11 | Bit 10 | Bit 9 | Bit 8 | Bit 7 | Bit 6 | Bit 5 | Bit 4 | Bit 3 | Bit 2 | Bit 1 | Bit 0 | All Resets(2) |
|-----------|------|--------|--------|--------|--------|--------|-----------|----------|-------|----------|----------|-------|----------|-------|-------|-------|-------|---------------|
| ANSA(1) | 04E0 | — | — | — | — | — | ANSA10(1) | ANSA9(1) | — | ANSA7(1) | ANSA6(1) | — | — | — | — | — | — | 06C0 |
| ANSB | 04E2 | ANSB15 | ANSB14 | ANSB13 | ANSB12 | ANSB11 | ANSB10 | ANSB9 | ANSB8 | ANSB7 | ANSB6 | ANSB5 | ANSB4 | ANSB3 | ANSB2 | ANSB1 | ANSB0 | FFFF |
| ANSC | 04E4 | — | ANSC14 | ANSC13 | — | — | — | — | — | — | — | — | ANSC4(1) | — | — | — | — | 6010 |
| ANSD | 04E6 | — | — | — | — | — | — | — | — | ANSD7 | ANSD6 | — | — | — | — | — | — | 00C0 |
| ANSE(1) | 04E8 | — | — | — | — | — | — | ANSE9(1) | — | — | — | — | — | — | — | — | — | 0200 |
| ANSF | 04EA | — | — | — | — | — | — | — | — | — | — | — | — | — | — | — | ANSF0 | 0001 |
| ANSG | 04EC | — | — | — | — | — | — | ANSG9 | ANSG8 | ANSG7 | ANSG6 | — | — | — | — | — | — | 03C0 |

Legend: — = unimplemented, read as '0'. Reset values are shown in hexadecimal.
Note 1: Unimplemented in 64-pin devices, read as '0'.
Note 2: Reset values are valid for 100-pin devices only.

TABLE 4-26: ENHANCED PARALLEL MASTER/SLAVE PORT REGISTER MAP⁽¹⁾

| File Name | Addr | Bit 15 | Bit 14 | Bit 13 | Bit 12 | Bit 11 | Bit 10 | Bit 9 | Bit 8 | Bit 7 | Bit 6 | Bit 5 | Bit 4 | Bit 3 | Bit 2 | Bit 1 | Bit 0 | All Resets |
|-----------|------|--------------------------------|--------|---------|---------|---------|---------|---------|---------|---------|---------|---------|---------|---------|---------|---------|---------|------------|
| PMCON1 | 0600 | PMPEN | — | PSIDL | ADRMUX1 | ADRMUX0 | — | MODE1 | MODE0 | CSF1 | CSF0 | ALP | ALMODE | — | BUSKEEP | IRQM1 | IRQM0 | 0000 |
| PMCON2 | 0602 | BUSY | — | ERROR | TIMEOUT | AMREQ | CURMST | MSTSEL1 | MSTSEL0 | RADDR23 | RADDR22 | RADDR21 | RADDR20 | RADDR19 | RADDR18 | RADDR17 | RADDR16 | 0000 |
| PMCON3 | 0604 | PTWREN | PTRDEN | PTBE1EN | PTBE0EN | — | AWAITM1 | AWAITM0 | AWAITE | — | PTEN22 | PTEN21 | PTEN20 | PTEN19 | PTEN18 | PTEN17 | PTEN16 | 0000 |
| PMCON4 | 0606 | PTEN15 | PTEN14 | PTEN13 | PTEN12 | PTEN11 | PTEN10 | PTEN9 | PTEN8 | PTEN7 | PTEN6 | PTEN5 | PTEN4 | PTEN3 | PTEN2 | PTEN1 | PTEN0 | 0000 |
| PMCS1CF | 0608 | CSDIS | CSP | CSP1EN | BEP | — | WRSP | RDSP | SM | ACKP | PTSZ1 | PTSZ0 | — | — | — | — | — | 0000 |
| PMCS1BS | 060A | BASE23 | BASE22 | BASE21 | BASE20 | BASE19 | BASE18 | BASE17 | BASE16 | BASE15 | — | — | — | BASE11 | — | — | — | 0200 |
| PMCS1MD | 060C | ACKM1 | ACKM0 | AMWAIT1 | AMWAIT0 | — | — | — | — | DWAITB1 | DWAITB0 | DWAITM3 | DWAITM2 | DWAITM1 | DWAITM0 | DWAITE1 | DWAITE0 | 0000 |
| PMCS2CF | 060E | CSDIS | CSP | CSP1EN | BEP | — | WRSP | RDSP | SM | ACKP | PTSZ1 | PTSZ0 | — | — | — | — | — | 0000 |
| PMCS2BS | 0610 | BASE23 | BASE22 | BASE21 | BASE20 | BASE19 | BASE18 | BASE17 | BASE16 | BASE15 | — | — | — | BASE11 | — | — | — | 0600 |
| PMCS2MD | 0612 | ACKM1 | ACKM0 | AMWAIT1 | AMWAIT0 | — | — | — | — | DWAITB1 | DWAITB0 | DWAITM3 | DWAITM2 | DWAITM1 | DWAITM0 | DWAITE1 | DWAITE0 | 0000 |
| PMDOOUT1 | 0614 | EPMP Data Out Register 1<15:8> | | | | | | | | | | | | | | | | |
| PMDOOUT2 | 0616 | EPMP Data Out Register 2<15:8> | | | | | | | | | | | | | | | | |
| PMDIN1 | 0618 | EPMP Data In Register 1<15:8> | | | | | | | | | | | | | | | | |
| PMDIN2 | 061A | EPMP Data In Register 2<15:8> | | | | | | | | | | | | | | | | |
| PMSTAT | 061C | IBF | IBOV | — | — | IB3F | IB2F | IB1F | IB0F | OBE | OBUF | — | — | OB3E | OB2E | OB1E | OB0E | 008F |
| | | EPMP Data Out Register 1<7:0> | | | | | | | | | | | | | | | | |
| | | EPMP Data Out Register 2<7:0> | | | | | | | | | | | | | | | | |
| | | EPMP Data In Register 1<7:0> | | | | | | | | | | | | | | | | |
| | | EPMP Data In Register 2<7:0> | | | | | | | | | | | | | | | | |

Legend: — = unimplemented, read as '0'. Reset values are shown in hexadecimal.
Note 1: Unimplemented in 64-pin devices, read as '0'.

TABLE 4-27: REAL-TIME CLOCK AND CALENDAR REGISTER MAP

| File Name | Addr | Bit 15 | Bit 14 | Bit 13 | Bit 12 | Bit 11 | Bit 10 | Bit 9 | Bit 8 | Bit 7 | Bit 6 | Bit 5 | Bit 4 | Bit 3 | Bit 2 | Bit 1 | Bit 0 | All Resets |
|-----------|------|---|--------|---------|---------|---------|--------|----------|----------|-------|-------|-------|-------|-------|-------|-------|-------|------------|
| ALRMVAL | 0620 | Alarm Value Register Window Based on ALRMPTR<1:0> | | | | | | | | | | | | | | | | |
| ALCFGRT | 0622 | ALRMEN | CHIME | AMASK3 | AMASK2 | AMASK1 | AMASK0 | ALRMPTR1 | ALRMPTR0 | ARPT7 | ARPT6 | ARPT5 | ARPT4 | ARPT3 | ARPT2 | ARPT1 | ARPT0 | 0000 |
| RTCVAL | 0624 | RTCC Value Register Window Based on RTCPTR<1:0> | | | | | | | | | | | | | | | | |
| RCFGCAL | 0626 | RTCEN | — | RTCWREN | RTCSYNC | HALFSEC | RTCOE | RTCPTR1 | RTCPTR0 | CAL7 | CAL6 | CAL5 | CAL4 | CAL3 | CAL2 | CAL1 | CAL0 | (Note 1) |
| | | xxxxx | | | | | | | | | | | | | | | | |
| | | xxxxx | | | | | | | | | | | | | | | | |

Legend: — = unimplemented, read as '0'. Reset values are shown in hexadecimal.
Note 1: The status of the RCFGAL register on POR is '0000' and on other Resets is unchanged.

PIC24FJ256DA210 FAMILY

[查询PIC24FJ256DA106供应商](#)

TABLE 4-28: COMPARATORS REGISTER MAP

| File Name | Addr | Bit 15 | Bit 14 | Bit 13 | Bit 12 | Bit 11 | Bit 10 | Bit 9 | Bit 8 | Bit 7 | Bit 6 | Bit 5 | Bit 4 | Bit 3 | Bit 2 | Bit 1 | Bit 0 | All Resets |
|-----------|------|--------|--------|--------|--------|--------|---------|---------|--------|--------|-------|-------|-------|-------|-------|-------|-------|------------|
| CMSTAT | 0630 | CMIDL | — | — | — | C3EVT | C2EVT | C1EVT | — | — | — | — | — | — | C3OUT | C2OUT | C1OUT | 0000 |
| CVRCON | 0632 | — | — | — | — | CVREFP | CVREFM1 | CVREFM0 | CVROE | CVREN | CVRR | CVRR | CVRSS | CVR3 | CVR2 | CVR1 | CVR0 | 0000 |
| CM1CON | 0634 | CON | COE | CPOL | — | — | CEVT | COUT | EVPOLO | EVPOL1 | — | — | CREF | — | — | CCH1 | CCH0 | 0000 |
| CM2CON | 0636 | CON | COE | CPOL | — | — | CEVT | COUT | EVPOLO | EVPOL1 | — | — | CREF | — | — | CCH1 | CCH0 | 0000 |
| CM3CON | 0638 | CON | COE | CPOL | — | — | CEVT | COUT | EVPOLO | EVPOL1 | — | — | CREF | — | — | CCH1 | CCH0 | 0000 |

Legend: — = unimplemented, read as '0'. Reset values are shown in hexadecimal.

TABLE 4-29: CRC REGISTER MAP

| File Name | Addr | Bit 15 | Bit 14 | Bit 13 | Bit 12 | Bit 11 | Bit 10 | Bit 9 | Bit 8 | Bit 7 | Bit 6 | Bit 5 | Bit 4 | Bit 3 | Bit 2 | Bit 1 | Bit 0 | All Resets |
|-----------|------|------------------------------|--------|--------|---------|---------|---------|---------|---------|--------|--------|---------|-------|---------|-------|-------|-------|------------|
| CRCCON1 | 0640 | CRCEN | — | CSIDL | VWORD4 | VWORD3 | VWORD2 | VWORD1 | VWORD0 | CRCFUL | CRCMPT | CRCISEL | CRCGO | LENDIAN | — | — | — | 0040 |
| CRCCON2 | 0642 | — | — | — | DWIDTH4 | DWIDTH3 | DWIDTH2 | DWIDTH1 | DWIDTH0 | — | — | — | PLEN4 | PLEN3 | PLEN2 | PLEN1 | PLEN0 | 0000 |
| CRCXORL | 0644 | X15 | X14 | X13 | X12 | X11 | X10 | X9 | X8 | X7 | X6 | X5 | X4 | X3 | X2 | X1 | — | 0000 |
| CRCXORH | 0646 | X31 | X30 | X29 | X28 | X27 | X26 | X25 | X24 | X23 | X22 | X21 | X20 | X19 | X18 | X17 | X16 | 0000 |
| CRCDATL | 0648 | CRC Data Input Register Low | | | | | | | | | | | | | | | | |
| CRCDATH | 064A | CRC Data Input Register High | | | | | | | | | | | | | | | | |
| CRCWDATL | 064C | CRC Result Register Low | | | | | | | | | | | | | | | | |
| CRCWDATH | 064E | CRC Result Register High | | | | | | | | | | | | | | | | |

Legend: — = unimplemented, read as '0'. Reset values are shown in hexadecimal.

TABLE 4-30: PERIPHERAL PIN SELECT REGISTER MAP

| File Name | Addr | Bit 15 | Bit 14 | Bit 13 | Bit 12 | Bit 11 | Bit 10 | Bit 9 | Bit 8 | Bit 7 | Bit 6 | Bit 5 | Bit 4 | Bit 3 | Bit 2 | Bit 1 | Bit 0 | All Resets |
|-----------|------|--------|--------|---------|---------|---------|---------|---------|---------|-------|-------|--------|--------|--------|--------|--------|--------|------------|
| RPINR0 | 0680 | — | — | INT1R5 | INT1R4 | INT1R3 | INT1R2 | INT1R1 | INT1R0 | — | — | — | — | — | — | — | — | 3F00 |
| RPINR1 | 0682 | — | — | INT3R5 | INT3R4 | INT3R3 | INT3R2 | INT3R1 | INT3R0 | — | — | INT2R5 | INT2R4 | INT2R3 | INT2R2 | INT2R1 | INT2R0 | 3F3F |
| RPINR2 | 0684 | — | — | — | — | — | — | — | — | — | — | INT4R5 | INT4R4 | INT4R3 | INT4R2 | INT4R1 | INT4R0 | 003F |
| RPINR3 | 0686 | — | — | T3CKR5 | T3CKR4 | T3CKR3 | T3CKR2 | T3CKR1 | T3CKR0 | — | — | T2CKR5 | T2CKR4 | T2CKR3 | T2CKR2 | T2CKR1 | T2CKR0 | 3F3F |
| RPINR4 | 0688 | — | — | T5CKR5 | T5CKR4 | T5CKR3 | T5CKR2 | T5CKR1 | T5CKR0 | — | — | T4CKR5 | T4CKR4 | T4CKR3 | T4CKR2 | T4CKR1 | T4CKR0 | 3F3F |
| RPINR7 | 068E | — | — | IC2R5 | IC2R4 | IC2R3 | IC2R2 | IC2R1 | IC2R0 | — | — | IC1R5 | IC1R4 | IC1R3 | IC1R2 | IC1R1 | IC1R0 | 3F3F |
| RPINR8 | 0690 | — | — | IC4R5 | IC4R4 | IC4R3 | IC4R2 | IC4R1 | IC4R0 | — | — | IC3R5 | IC3R4 | IC3R3 | IC3R2 | IC3R1 | IC3R0 | 3F3F |
| RPINR9 | 0692 | — | — | IC6R5 | IC6R4 | IC6R3 | IC6R2 | IC6R1 | IC6R0 | — | — | IC5R5 | IC5R4 | IC5R3 | IC5R2 | IC5R1 | IC5R0 | 3F3F |
| RPINR10 | 0694 | — | — | IC8R5 | IC8R4 | IC8R3 | IC8R2 | IC8R1 | IC8R0 | — | — | IC7R5 | IC7R4 | IC7R3 | IC7R2 | IC7R1 | IC7R0 | 3F3F |
| RPINR11 | 0696 | — | — | OCFBR5 | OCFBR4 | OCFBR3 | OCFBR2 | OCFBR1 | OCFBR0 | — | — | OCFAR5 | OCFAR4 | OCFAR3 | OCFAR2 | OCFAR1 | OCFAR0 | 3F3F |
| RPINR15 | 069E | — | — | IC9R5 | IC9R4 | IC9R3 | IC9R2 | IC9R1 | IC9R0 | — | — | — | — | — | — | — | — | 3F00 |
| RPINR17 | 06A2 | — | — | U3RXR5 | U3RXR4 | U3RXR3 | U3RXR2 | U3RXR1 | U3RXR0 | — | — | — | — | — | — | — | — | 3F00 |
| RPINR18 | 06A4 | — | — | U1CTSR5 | U1CTSR4 | U1CTSR3 | U1CTSR2 | U1CTSR1 | U1CTSR0 | — | — | U1RXR5 | U1RXR4 | U1RXR3 | U1RXR2 | U1RXR1 | U1RXR0 | 3F3F |
| RPINR19 | 06A6 | — | — | U2CTSR5 | U2CTSR4 | U2CTSR3 | U2CTSR2 | U2CTSR1 | U2CTSR0 | — | — | U2RXR5 | U2RXR4 | U2RXR3 | U2RXR2 | U2RXR1 | U2RXR0 | 3F3F |
| RPINR20 | 06A8 | — | — | SCK1R5 | SCK1R4 | SCK1R3 | SCK1R2 | SCK1R1 | SCK1R0 | — | — | SD1R5 | SD1R4 | SD1R3 | SD1R2 | SD1R1 | SD1R0 | 3F3F |
| RPINR21 | 06AA | — | — | U3CTSR5 | U3CTSR4 | U3CTSR3 | U3CTSR2 | U3CTSR1 | U3CTSR0 | — | — | SS1R5 | SS1R4 | SS1R3 | SS1R2 | SS1R1 | SS1R0 | 3F3F |
| RPINR22 | 06AC | — | — | SCK2R5 | SCK2R4 | SCK2R3 | SCK2R2 | SCK2R1 | SCK2R0 | — | — | SDI2R5 | SDI2R4 | SDI2R3 | SDI2R2 | SDI2R1 | SDI2R0 | 3F3F |
| RPINR23 | 06AE | — | — | — | — | — | — | — | — | — | — | SS2R5 | SS2R4 | SS2R3 | SS2R2 | SS2R1 | SS2R0 | 003F |
| RPINR27 | 06B6 | — | — | U4CTSR5 | U4CTSR4 | U4CTSR3 | U4CTSR2 | U4CTSR1 | U4CTSR0 | — | — | U4RXR5 | U4RXR4 | U4RXR3 | U4RXR2 | U4RXR1 | U4RXR0 | 3F3F |
| RPINR28 | 06B8 | — | — | SCK3R5 | SCK3R4 | SCK3R3 | SCK3R2 | SCK3R1 | SCK3R0 | — | — | SDI3R5 | SDI3R4 | SDI3R3 | SDI3R2 | SDI3R1 | SDI3R0 | 3F3F |
| RPINR29 | 06BA | — | — | — | — | — | — | — | — | — | — | SS3R5 | SS3R4 | SS3R3 | SS3R2 | SS3R1 | SS3R0 | 003F |

Legend: — = unimplemented, read as '0'. Reset values are shown in hexadecimal.

Note 1: Bits are unimplemented in 64-pin devices; read as '0'.

PIC24FJ256DA210 FAMILY

[查询PIC24FJ256DA106供应商](#)

TABLE 4-30: PERIPHERAL PIN SELECT REGISTER MAP (CONTINUED)

| File Name | Addr | Bit 15 | Bit 14 | Bit 13 | Bit 12 | Bit 11 | Bit 10 | Bit 9 | Bit 8 | Bit 7 | Bit 6 | Bit 5 | Bit 4 | Bit 3 | Bit 2 | Bit 1 | Bit 0 | All Resets |
|-----------------------|------|--------|--------|-----------------------|-----------------------|-----------------------|-----------------------|-----------------------|-----------------------|-------|-------|-----------------------|-----------------------|-----------------------|-----------------------|-----------------------|-----------------------|------------|
| RPOR0 | 06C0 | — | — | RP1R5 | RP1R4 | RP1R3 | RP1R2 | RP1R1 | RP1R0 | — | — | RP0R5 | RP0R4 | RP0R3 | RP0R2 | RP0R1 | RP0R0 | 0000 |
| RPOR1 | 06C2 | — | — | RP3R5 | RP3R4 | RP3R3 | RP3R2 | RP3R1 | RP3R0 | — | — | RP2R5 | RP2R4 | RP2R3 | RP2R2 | RP2R1 | RP2R0 | 0000 |
| RPOR2 | 06C4 | — | — | RP5R5 ⁽¹⁾ | RP5R4 ⁽¹⁾ | RP5R3 ⁽¹⁾ | RP5R2 ⁽¹⁾ | RP5R1 ⁽¹⁾ | RP5R0 ⁽¹⁾ | — | — | RP4R5 | RP4R4 | RP4R3 | RP4R2 | RP4R1 | RP4R0 | 0000 |
| RPOR3 | 06C6 | — | — | RP7R5 | RP7R4 | RP7R3 | RP7R2 | RP7R1 | RP7R0 | — | — | RP6R5 | RP6R4 | RP6R3 | RP6R2 | RP6R1 | RP6R0 | 0000 |
| RPOR4 | 06C8 | — | — | RP9R5 | RP9R4 | RP9R3 | RP9R2 | RP9R1 | RP9R0 | — | — | RP8R5 | RP8R4 | RP8R3 | RP8R2 | RP8R1 | RP8R0 | 0000 |
| RPOR5 | 06CA | — | — | RP11R5 | RP11R4 | RP11R3 | RP11R2 | RP11R1 | RP11R0 | — | — | RP10R5 | RP10R4 | RP10R3 | RP10R2 | RP10R1 | RP10R0 | 0000 |
| RPOR6 | 06CC | — | — | RP13R5 | RP13R4 | RP13R3 | RP13R2 | RP13R1 | RP13R0 | — | — | RP12R5 | RP12R4 | RP12R3 | RP12R2 | RP12R1 | RP12R0 | 0000 |
| RPOR7 | 06CE | — | — | RP15R5 ⁽¹⁾ | RP15R4 ⁽¹⁾ | RP15R3 ⁽¹⁾ | RP15R2 ⁽¹⁾ | RP15R1 ⁽¹⁾ | RP15R0 ⁽¹⁾ | — | — | RP14R5 | RP14R4 | RP14R3 | RP14R2 | RP14R1 | RP14R0 | 0000 |
| RPOR8 | 06D0 | — | — | RP17R5 | RP17R4 | RP17R3 | RP17R2 | RP17R1 | RP17R0 | — | — | RP16R5 | RP16R4 | RP16R3 | RP16R2 | RP16R1 | RP16R0 | 0000 |
| RPOR9 | 06D2 | — | — | RP19R5 | RP19R4 | RP19R3 | RP19R2 | RP19R1 | RP19R0 | — | — | RP18R5 | RP18R4 | RP18R3 | RP18R2 | RP18R1 | RP18R0 | 0000 |
| RPOR10 | 06D4 | — | — | RP21R5 | RP21R4 | RP21R3 | RP21R2 | RP21R1 | RP21R0 | — | — | RP20R5 | RP20R4 | RP20R3 | RP20R2 | RP20R1 | RP20R0 | 0000 |
| RPOR11 | 06D6 | — | — | RP23R5 | RP23R4 | RP23R3 | RP23R2 | RP23R1 | RP23R0 | — | — | RP22R5 | RP22R4 | RP22R3 | RP22R2 | RP22R1 | RP22R0 | 0000 |
| RPOR12 | 06D8 | — | — | RP25R5 | RP25R4 | RP25R3 | RP25R2 | RP25R1 | RP25R0 | — | — | RP24R5 | RP24R4 | RP24R3 | RP24R2 | RP24R1 | RP24R0 | 0000 |
| RPOR13 | 06DA | — | — | RP27R5 | RP27R4 | RP27R3 | RP27R2 | RP27R1 | RP27R0 | — | — | RP26R5 | RP26R4 | RP26R3 | RP26R2 | RP26R1 | RP26R0 | 0000 |
| RPOR14 | 06DC | — | — | RP29R5 | RP29R4 | RP29R3 | RP29R2 | RP29R1 | RP29R0 | — | — | RP28R5 | RP28R4 | RP28R3 | RP28R2 | RP28R1 | RP28R0 | 0000 |
| RPOR15 ⁽¹⁾ | 06DE | — | — | RP31R5 ⁽¹⁾ | RP31R4 ⁽¹⁾ | RP31R3 ⁽¹⁾ | RP31R2 ⁽¹⁾ | RP31R1 ⁽¹⁾ | RP31R0 ⁽¹⁾ | — | — | RP30R5 ⁽¹⁾ | RP30R4 ⁽¹⁾ | RP30R3 ⁽¹⁾ | RP30R2 ⁽¹⁾ | RP30R1 ⁽¹⁾ | RP30R0 ⁽¹⁾ | 0000 |

Legend: — = unimplemented, read as '0'. Reset values are shown in hexadecimal.

Note 1: Bits are unimplemented in 64-pin devices; read as '0'.

PIC24FJ256DA210 FAMILY

查询PIC24FJ256DA106供应商

TABLE 4-31: GRAPHICS REGISTER MAP

| File Name | Addr | Bit 15 | Bit 14 | Bit 13 | Bit 12 | Bit 11 | Bit 10 | Bit 9 | Bit 8 | Bit 7 | Bit 6 | Bit 5 | Bit 4 | Bit 3 | Bit 2 | Bit 1 | Bit 0 | All Resets |
|--|------|----------|----------|----------|-----------|-----------|-----------|-----------|-----------|---------|---------|---------|----------|----------|----------|----------|----------|------------|
| G1CMDL | 0700 | | | | | | | | | | | | | | | | | 0000 |
| G1CMDH | 0702 | | | | | | | | | | | | | | | | | 0000 |
| Graphics Command Register<15:0> | | | | | | | | | | | | | | | | | | |
| Graphics Command Register<31:16> | | | | | | | | | | | | | | | | | | |
| G1CON1 | 0704 | G1EN | | G1SIDL | G1CMDWMK4 | G1CMDWMK3 | G1CMDWMK2 | G1CMDWMK1 | G1CMDWMK0 | PUBPP2 | PUBPP1 | PUBPP0 | G1MDCNT4 | G1MDCNT3 | G1MDCNT2 | G1MDCNT1 | G1MDCNT0 | 0000 |
| G1STAT | 0706 | PUBUSY | | | | | | | | IPUBUSY | RCCBUSY | CHRBUSY | VMRGN | HMRGN | CMDLV | CMDFUL | CMDMPT | 0000 |
| G1IE | 0708 | PIUE | | | | | | | | PIUJE | RCCIE | CHRIE | VMRGNIE | HMRGNIE | CMDLVIE | CMDFULIE | CMDMPTIE | 0000 |
| G1HIR | 070A | PIUF | | | | | | | | PIUJF | RCCIF | CHRIF | VMRGNIF | HMRGNIF | CMDLVIF | CMDFULIF | CMDMPTIF | 0000 |
| G1W1ADRL | 070C | | | | | | | | | | | | | | | | | 0000 |
| GPU Work Area 1 Start Address Register<15:0> | | | | | | | | | | | | | | | | | | |
| G1W1ADRH | 070E | | | | | | | | | | | | | | | | | 0000 |
| GPU Work Area 2 Start Address Register<15:0> | | | | | | | | | | | | | | | | | | |
| G1W2ADRL | 0710 | | | | | | | | | | | | | | | | | 0000 |
| G1W2ADRH | 0712 | | | | | | | | | | | | | | | | | 0000 |
| G1PUW | 0714 | | | | | | | | | | | | | | | | | 0000 |
| G1PUH | 0716 | | | | | | | | | | | | | | | | | 0000 |
| GPU Work Area Width Register | | | | | | | | | | | | | | | | | | |
| GPU Work Area Height Register | | | | | | | | | | | | | | | | | | |
| G1DPADRL | 0718 | | | | | | | | | | | | | | | | | 0000 |
| Display Buffer Start Address Register<15:0> | | | | | | | | | | | | | | | | | | |
| G1DPADRH | 071A | | | | | | | | | | | | | | | | | 0000 |
| G1DPW | 071C | | | | | | | | | | | | | | | | | 0000 |
| G1DPH | 071E | | | | | | | | | | | | | | | | | 0000 |
| G1DPWT | 0720 | | | | | | | | | | | | | | | | | 0000 |
| G1DPHT | 0722 | | | | | | | | | | | | | | | | | 0000 |
| Display Total Width Register | | | | | | | | | | | | | | | | | | |
| Display Total Height Register | | | | | | | | | | | | | | | | | | |
| G1CON2 | 0724 | DPGWDTH1 | DPGWDTH0 | DPSTGER1 | DPSTGER0 | DPTST0 | DPTST1 | DPTST2 | DPBPP0 | DPBPP1 | DPBPP2 | DPBPP3 | DPBPP4 | DPBPP5 | DPBPP6 | DPBPP7 | DPBPP8 | 0000 |
| G1CON3 | 0726 | | | | | | | | DPVSPOL | DPVSPOL | DPVSPOL | DPVSPOL | DPVSPOL | DPVSPOL | DPVSPOL | DPVSPOL | DPVSPOL | 0000 |
| G1ACTDA | 0728 | | | | | | | | | | | | | | | | | 0000 |
| Number of Lines Before the First Active Line Register | | | | | | | | | | | | | | | | | | |
| G1HSYNC | 072A | | | | | | | | | | | | | | | | | 0000 |
| HSYNC Pulse-Width Configuration Register | | | | | | | | | | | | | | | | | | |
| G1VSYNC | 072C | | | | | | | | | | | | | | | | | 0000 |
| VSYNC Pulse-Width Configuration Register | | | | | | | | | | | | | | | | | | |
| G1DBLCON | 072E | | | | | | | | | | | | | | | | | 0000 |
| Vertical Blanking Start to First Displayed Line Configuration Register | | | | | | | | | | | | | | | | | | |
| G1GLUT | 0730 | CLUTEN | CLUTBUSY | | | | | CLUTTRD | CLUTRWEN | | | | | | | | | 0000 |
| Color Look-up Table Memory Write Data Register | | | | | | | | | | | | | | | | | | |
| G1GLUTWR | 0732 | | | | | | | | | | | | | | | | | 0000 |
| Color Look-up Table Memory Read Data Register | | | | | | | | | | | | | | | | | | |
| G1GLUTRD | 0734 | | | | | | | | | | | | | | | | | 0000 |
| Vertical Blanking Advance Register | | | | | | | | | | | | | | | | | | |
| G1MRGN | 0736 | | | | | | | | | | | | | | | | | 0000 |
| Horizontal Blanking Advance Register | | | | | | | | | | | | | | | | | | |
| G1CHRX | 0738 | | | | | | | | | | | | | | | | | 0000 |
| Current Character X-Coordinate Position Register | | | | | | | | | | | | | | | | | | |
| G1CHRY | 073A | | | | | | | | | | | | | | | | | 0000 |
| Current Character Y-Coordinate Position Register | | | | | | | | | | | | | | | | | | |
| G1IPU | 073C | | | | | | | | | | | | | | | | | 0000 |
| HUFFERR | | | | | | | | | | | | | | | | | | |
| G1DBEN | 073E | GDBEN15 | GDBEN14 | GDBEN13 | GDBEN12 | GDBEN11 | GDBEN10 | GDBEN9 | GDBEN8 | GDBEN7 | GDBEN6 | GDBEN5 | GDBEN4 | GDBEN3 | GDBEN2 | GDBEN1 | GDBEN0 | 0000 |
| WRAPERR | | | | | | | | | | | | | | | | | | |
| LENERR | | | | | | | | | | | | | | | | | | |
| BLCKERR | | | | | | | | | | | | | | | | | | |
| IPUDONE | | | | | | | | | | | | | | | | | | |
| BFINAL | | | | | | | | | | | | | | | | | | |

Legend: — = unimplemented, read as '0'. Reset values are shown in hexadecimal.

PIC24FJ256DA210 FAMILY

查询PIC24FJ256DA106供应商

TABLE 4-32: SYSTEM REGISTER MAP

| File Name | Addr | Bit 15 | Bit 14 | Bit 13 | Bit 12 | Bit 11 | Bit 10 | Bit 9 | Bit 8 | Bit 7 | Bit 6 | Bit 5 | Bit 4 | Bit 3 | Bit 2 | Bit 1 | Bit 0 | All Resets |
|-----------|------|----------|----------|----------|----------|----------|----------|----------|--------|---------|--------|--------|----------|-------|--------|--------|-------|------------|
| RCON | 0740 | TRAPR | IOPUWR | — | — | — | — | CM | VRECS | EXTR | SWR | SWDTEN | WDTO | SLEEP | IDLE | BOR | POR | Note 1 |
| OSCCON | 0742 | — | COSC2 | COSC1 | COSC0 | — | NOSC2 | NOSC1 | NOSC0 | CLKLOCK | IOLCK | LOCK | — | CF | POSCEN | SOSCEN | OSWEN | Note 2 |
| CLKDIV | 0744 | ROI | DOZE2 | DOZE1 | DOZE0 | DOZEN | RCDIV2 | RCDIV1 | RCDIV0 | CPDIV1 | CPDIV0 | PLEN | G1CLKSEL | — | — | — | — | 0100 |
| CLKDIV2 | 0746 | GCLKDIV6 | GCLKDIV5 | GCLKDIV4 | GCLKDIV3 | GCLKDIV2 | GCLKDIV1 | GCLKDIV0 | — | — | — | — | — | — | — | — | — | 0000 |
| OSCTUN | 0748 | — | — | — | — | — | — | — | — | — | — | TUN5 | TUN4 | TUN3 | TUN2 | TUN1 | TUN0 | 0000 |
| REFOCON | 074E | ROEN | — | ROSSLP | ROSEL | RODIV3 | RODIV2 | RODIV1 | RODIV0 | — | — | — | — | — | — | — | — | 0000 |

Legend: — = unimplemented, read as '0'; Reset values are shown in hexadecimal.

Note 1: The Reset value of the RCON register is dependent on the type of Reset event. See Section 6.0 "Resets" for more information.

Note 2: The Reset value of the OSCCON register is dependent on both the type of Reset event and the device configuration. See Section 8.0 "Oscillator Configuration" for more information.

TABLE 4-33: NVM REGISTER MAP

| File Name | Addr | Bit 15 | Bit 14 | Bit 13 | Bit 12 | Bit 11 | Bit 10 | Bit 9 | Bit 8 | Bit 7 | Bit 6 | Bit 5 | Bit 4 | Bit 3 | Bit 2 | Bit 1 | Bit 0 | All Resets |
|-----------|------|--------|--------|--------|--------|--------|--------|-------|-------|-------|-------|-------|-------|--------|--------|--------|--------|------------|
| NVMCON | 0760 | WFR | WREN | WRERR | — | — | — | — | — | — | ERASE | — | — | NVMOP3 | NVMOP2 | NVMOP1 | NVMOP0 | 0000(f) |
| NVMKEY | 0766 | — | — | — | — | — | — | — | — | — | — | — | — | — | — | — | — | 0000 |

NVMKEY Register<7:0>

Legend: — = unimplemented, read as '0'; Reset values are shown in hexadecimal.

Note 1: The Reset value shown is for POR only. Value on other Reset states is dependent on the state of memory write or erase operations at the time of Reset.

TABLE 4-34: PMD REGISTER MAP

| File Name | Addr | Bit 15 | Bit 14 | Bit 13 | Bit 12 | Bit 11 | Bit 10 | Bit 9 | Bit 8 | Bit 7 | Bit 6 | Bit 5 | Bit 4 | Bit 3 | Bit 2 | Bit 1 | Bit 0 | All Resets |
|-----------|------|--------|--------|--------|--------|--------|--------|--------|----------|--------|--------|-------|--------|--------|--------|--------|--------|------------|
| PMD1 | 0770 | T5MD | T4MD | T3MD | T2MD | T1MD | — | — | — | I2C1MD | U2MD | U1MD | SPI2MD | SPI1MD | — | — | ADC1MD | 0000 |
| PMD2 | 0772 | IC8MD | IC7MD | IC6MD | IC5MD | IC4MD | IC3MD | IC2MD | IC1MD | OC8MD | OC7MD | OC6MD | OC5MD | OC4MD | OC3MD | OC2MD | OC1MD | 0000 |
| PMD3 | 0774 | — | — | — | — | — | CMPMD | RTCCMD | PMPMD(f) | CRCMD | — | — | — | U3MD | I2C3MD | I2C2MD | — | 0000 |
| PMD4 | 0776 | — | — | — | — | — | — | — | — | — | UPWMMD | U4MD | — | REFOMD | CTMUMD | LVDMD | USB1MD | 0000 |
| PMD5 | 0778 | — | — | — | — | — | — | — | IC9MD | — | — | — | — | — | — | — | OC9MD | 0000 |
| PMD6 | 077A | — | — | — | — | — | — | — | — | — | GFX1MD | — | — | — | — | — | SPI3MD | 0000 |

Legend: — = unimplemented, read as '0'; Reset values are shown in hexadecimal.

Note 1: Unimplemented in 64-pin devices, read as '0'.

PIC24FJ256DA210 FAMILY

[查询PIC24FJ256DA106供应商](#)

4.2.5 EXTENDED DATA SPACE (EDS)

The enhancement of the data space in PIC24FJ256DA210 family devices has been accomplished by a new technique, called the Extended Data Space (EDS).

The EDS includes any additional internal extended data memory not accessible by the lower 32 Kbytes data address space, any external memory through EPMP and the Program Space Visibility (PSV).

The extended data space is always accessed through the EDS window, the upper half of data space. The entire extended data space is organized into EDS

pages, each having 32 Kbytes of data. Mapping of the EDS page into the EDS window is done using the Data Space Read register (DSRPAG<9:0>) for read operations and Data Space Write register (DSWPAG<8:0>) for write operations. Figure 4-4 displays the entire EDS space.

Note: Accessing Page 0 in the EDS window will generate an address error trap as Page 0 is the base data memory (data locations, 0x0800 to 0x7FFF, in the lower data space).

FIGURE 4-4: EXTENDED DATA SPACE

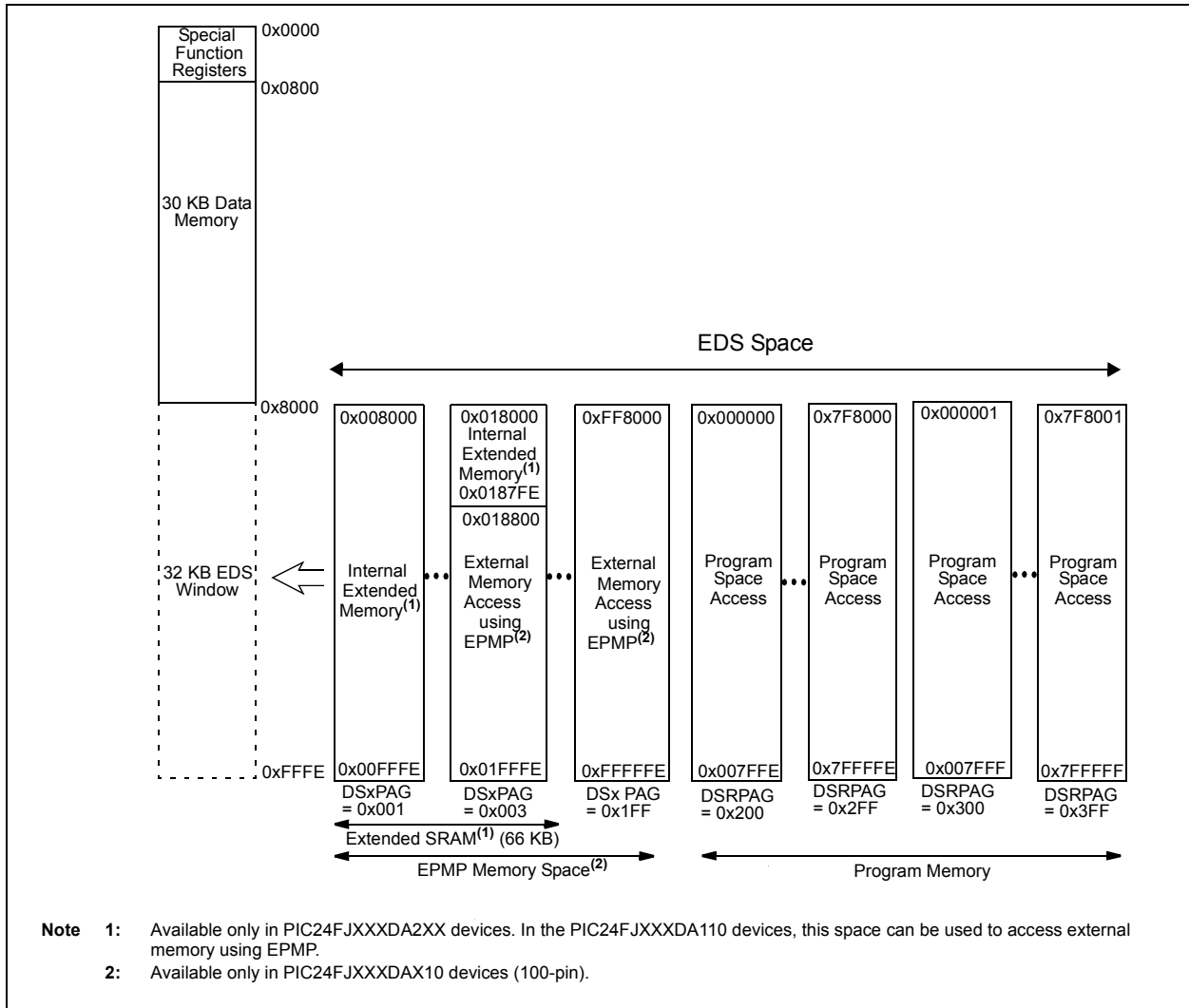

PIC24FJ256DA210 FAMILY

[查询PIC24FJ256DA106供应商](#)

4.2.5.1 Data Read from EDS Space

In order to read the data from the EDS space, first, an Address Pointer is set up by loading the required EDS page number into the DSRPAG register and assigning the offset address to one of the W registers. Once the above assignment is done, the EDS window is enabled

by setting bit 15 of the working register, assigned with the offset address; then, the contents of the pointed EDS location can be read.

Figure 4-5 illustrates how the EDS space address is generated for read operations.

FIGURE 4-5: EDS ADDRESS GENERATION FOR READ OPERATIONS

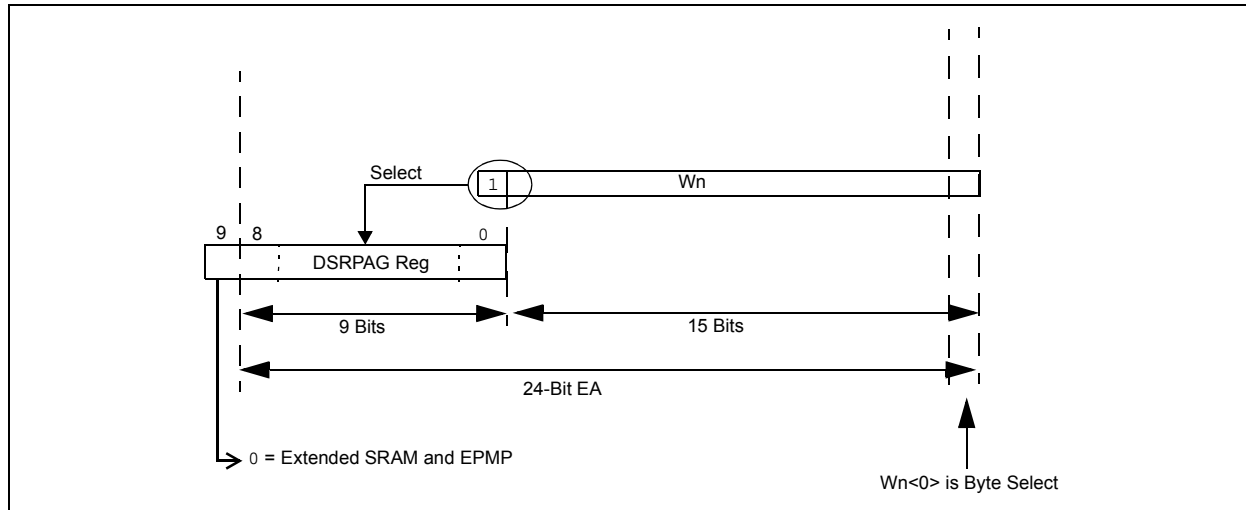

When the Most Significant bit (MSBs) of EA is '1' and DSRPAG<9> = 0, the lower 9 bits of DSRPAG are concatenated to the lower 15 bits of EA to form a 24-bit EDS space address for read operations.

Example 4-1 shows how to read a byte, word and double-word from EDS.

Note: All read operations from EDS space have an overhead of one instruction cycle. Therefore, a minimum of two instruction cycles is required to complete an EDS read. EDS reads under the REPEAT instruction; the first two accesses take three cycles and the subsequent accesses take one cycle.

EXAMPLE 4-1: EDS READ CODE IN ASSEMBLY

```

; Set the EDS page from where the data to be read
mov    #0x0002 , w0
mov    w0 , DSRPAG    ;page 2 is selected for read
mov    #0x0800 , w1    ;select the location (0x800) to be read
bset   w1 , #15       ;set the MSB of the base address, enable EDS mode

;Read a byte from the selected location
mov.b  [w1++] , w2    ;read Low byte
mov.b  [w1++] , w3    ;read High byte

;Read a word from the selected location
mov    [w1] , w2      ;

;Read Double - word from the selected location
mov.d  [w1] , w2      ;two word read, stored in w2 and w3
    
```

PIC24FJ256DA210 FAMILY

[查询PIC24FJ256DA106供应商](#)

4.2.5.2 Data Write into EDS Space

In order to write data to EDS space, such as in EDS reads, an Address Pointer is set up by loading the required EDS page number into the DSWPAG register, and assigning the offset address to one of the W registers. Once the above assignment is done, then the

EDS window is enabled by setting bit 15 of the working register, assigned with the offset address, and the accessed location can be written.

Figure 4-2 illustrates how the EDS space address is generated for write operations.

FIGURE 4-6: EDS ADDRESS GENERATION FOR WRITE OPERATIONS

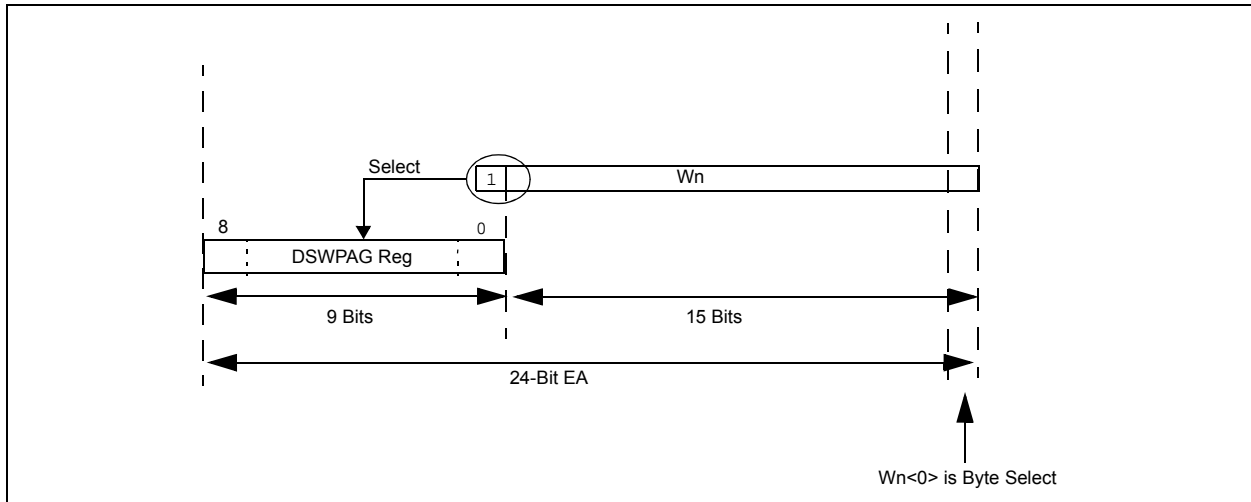

When the MSBs of EA is '1', the lower 9 bits of DSWPAG are concatenated to the lower 15 bits of EA to form a 24-bit EDS address for write operations. Example 4-2 shows how to write a byte, word and double-word to EDS.

EXAMPLE 4-2: EDS WRITE CODE IN ASSEMBLY

```
; Set the EDS page where the data to be written
mov    #0x0002 , w0
mov    w0 , DSWPAG    ;page 2 is selected for write
mov    #0x0800 , w1    ;select the location (0x800) to be written
bset   w1 , #15       ;set the MSB of the base address, enable EDS mode

;Write a byte to the selected location
mov    #0x00A5 , w2
mov    #0x003C , w3
mov.b  w2 , [w1++]    ;write Low byte
mov.b  w3 , [w1++]    ;write High byte

;Write a word to the selected location
mov    #0x1234 , w2 ;
mov    w2 , [w1] ;

;Write a Double - word to the selected location
mov    #0x1122 , w2
mov    #0x4455 , w3
mov.d  w2 , [w1] ;2 EDS writes
```

PIC24FJ256DA210 FAMILY

[查询PIC24FJ256DA106供应商](#)

The page registers (DSRPAG/DSWPAG) do not update automatically while crossing a page boundary, when the rollover happens from 0xFFFF to 0x8000. While developing code in assembly, care must be taken to update the page registers when an Address Pointer crosses the page boundary. The 'C' compiler keeps track of the addressing, and increments or decrements the page registers accordingly while accessing contiguous data memory locations.

- Note 1:** All write operations to EDS are executed in a single cycle.
- 2:** Use of Read/Modify/Write operation on any EDS location under a REPEAT instruction is not supported. For example, BCLR, BSW, BTG, RLC f, RLNC f, RRC f, RRNC f, ADD f, SUB f, SUBR f, AND f, IOR f, XOR f, ASR f, ASL f.
- 3:** Use the DSRPAG register while performing Read/Modify/Write operation.

TABLE 4-35: EDS MEMORY ADDRESS WITH DIFFERENT PAGES AND ADDRESSES

| DSRPAG (Data Space Read Register) | DSWPAG (Data Space Write Register) | Source/Destination Address while Indirect Addressing | 24-Bit EA Pointing to EDS | Comment |
|--------------------------------------|---------------------------------------|--|---------------------------------|---|
| x ⁽¹⁾ | x ⁽¹⁾ | 0x0000 to 0x1FFF | 0x000000 to 0x001FFF | Near data space ⁽²⁾ |
| | | 0x2000 to 0x7FFF | 0x002000 to 0x007FFF | |
| 0x001 | 0x001 | 0x8000 to 0xFFFF | 0x008000 to 0x00FFFE | 32 Kbytes on each page |
| 0x002 | 0x002 | | 0x010000 to 0x017FFE | |
| 0x003 | 0x003 | | 0x018000 to 0x0187FE | Only 2 Kbytes of extended SRAM on this page |
| 0x004 | 0x004 | | 0x018800 to 0x027FFE | EPMP memory space ⁽⁴⁾ |
| • | • | | • | |
| • | • | | • | |
| 0x1FF | 0x1FF | | 0xFF8000 to 0xFFFFFE | |
| 0x000 | 0x000 | | Invalid Address | Address error trap ⁽³⁾ |

- Note 1:** If the source/destination address is below 0x8000, the DSRPAG and DSWPAG registers are not considered.
- 2:** This data space can also be accessed by Direct Addressing.
- 3:** When the source/destination address is above 0x8000 and DSRPAG/DSWPAG is '0', an address error trap will occur.
- 4:** EPMP memory space can start from location, 0x008000, in the parts with 24 Kbytes of data memory (PIC24FJXXXDA1XX)

Apart from its use as a working register, the W15 register in PIC24F devices is also used as a Software Stack Pointer (SSP). The pointer always points to the first available free word and grows from lower to higher addresses. It pre-decrements for stack pops and post-increments for stack pushes, as shown in Figure 4-7. Note that for a PC push during any CALL instruction, the MSB of the PC is zero-extended before the push, ensuring that the MSB is always clear.

Note: A PC push during exception processing will concatenate the SRL register to the MSB of the PC prior to the push.

The Stack Pointer Limit Value register (SPLIM), associated with the Stack Pointer, sets an upper address boundary for the stack. SPLIM is uninitialized at Reset. As is the case for the Stack Pointer, SPLIM<0> is forced to '0' as all stack operations must be word-aligned. Whenever an EA is generated using W15 as a source or destination pointer, the resulting address is compared with the value in SPLIM. If the contents of the Stack Pointer (W15) and the SPLIM register are equal, and a push operation is performed, a stack error trap will not occur. The stack error trap will occur on a subsequent push operation. Thus, for example, if it is desirable to cause a stack error trap when the stack grows beyond address 2000h in RAM, initialize the SPLIM with the value, 1FFEh.

Similarly, a Stack Pointer underflow (stack error) trap is generated when the Stack Pointer address is found to be less than 0800h. This prevents the stack from interfering with the SFR space.

A write to the SPLIM register should not be immediately followed by an indirect read operation using W15.

FIGURE 4-7: CALL STACK FRAME

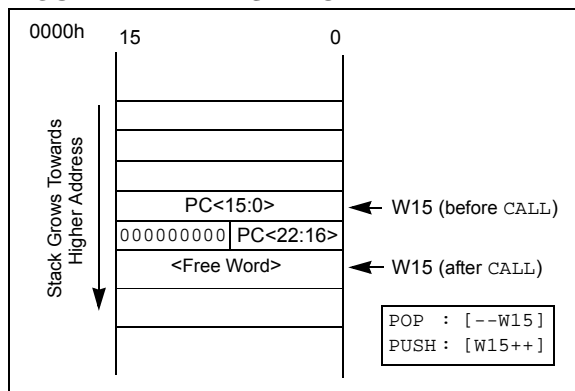

4.3 Interfacing Program and Data Memory Spaces

The PIC24F architecture uses a 24-bit wide program space and 16-bit wide data space. The architecture is also a modified Harvard scheme, meaning that data can also be present in the program space. To use this data successfully, it must be accessed in a way that preserves the alignment of information in both spaces.

Aside from normal execution, the PIC24F architecture provides two methods by which program space can be accessed during operation:

- Using table instructions to access individual bytes or words anywhere in the program space
- Remapping a portion of the program space into the data space (program space visibility)

Table instructions allow an application to read or write to small areas of the program memory. This makes the method ideal for accessing data tables that need to be updated from time to time. It also allows access to all bytes of the program word. The remapping method allows an application to access a large block of data on a read-only basis, which is ideal for look ups from a large table of static data. It can only access the least significant word of the program word.

4.3.1 ADDRESSING PROGRAM SPACE

Since the address ranges for the data and program spaces are 16 and 24 bits, respectively, a method is needed to create a 23-bit or 24-bit program address from 16-bit data registers. The solution depends on the interface method to be used.

For table operations, the 8-bit Table Memory Page Address register (TBLPAG) is used to define a 32K word region within the program space. This is concatenated with a 16-bit EA to arrive at a full 24-bit program space address. In this format, the MSBs of TBLPAG is used to determine if the operation occurs in the user memory (TBLPAG<7> = 0) or the configuration memory (TBLPAG<7> = 1).

For remapping operations, the 10-bit Extended Data Space Read register (DSRPAG) is used to define a 16K word page in the program space. When the Most Significant bit (MSb) of the EA is '1', and the MSb (bit 9) of DSRPAG is '1', the lower 8 bits of DSRPAG are concatenated with the lower 15 bits of the EA to form a 23-bit program space address. The DSRPAG<8> bit decides whether the lower word (when bit is '0') or the higher word (when bit is '1') of program memory is mapped. Unlike table operations, this strictly limits remapping operations to the user memory area.

Table 4-36 and Figure 4-8 show how the program EA is created for table operations and remapping accesses from the data EA. Here, P<23:0> refers to a program space word, whereas D<15:0> refers to a data space word.

PIC24FJ256DA210 FAMILY

查询PIC24FJ256DA106供应商

TABLE 4-36: PROGRAM SPACE ADDRESS CONSTRUCTION

| Access Type | Access Space | Program Space Address | | | | |
|--|---------------|------------------------------|----------------------------|---------------------|------------------------------|-----|
| | | <23> | <22:16> | <15> | <14:1> | <0> |
| Instruction Access (Code Execution) | User | 0 | PC<22:1> | | | 0 |
| | | 0xx xxxx xxxx xxxx xxxx xxx0 | | | | |
| TBLRD/TBLWT (Byte/Word Read/Write) | User | TBLPAG<7:0> | | Data EA<15:0> | | |
| | | 0xxx xxxx | | xxxx xxxx xxxx xxxx | | |
| | Configuration | TBLPAG<7:0> | | Data EA<15:0> | | |
| | | 1xxx xxxx | | xxxx xxxx xxxx xxxx | | |
| Program Space Visibility (Block Remap/Read) | User | 0 | DSRPAG<7:0> ⁽²⁾ | | Data EA<14:0> ⁽¹⁾ | |
| | | 0 | xxxx xxxx | | xxx xxxx xxxx xxxx | |

Note 1: Data EA<15> is always '1' in this case, but is not used in calculating the program space address. Bit 15 of the address is DSRPAG<0>.

2: DSRPAG<9> is always '1' in this case. DSRPAG<8> decides whether the lower word or higher word of program memory is read. When DSRPAG<8> is '0', the lower word is read and when it is '1', the higher word is read.

FIGURE 4-8: DATA ACCESS FROM PROGRAM SPACE ADDRESS GENERATION

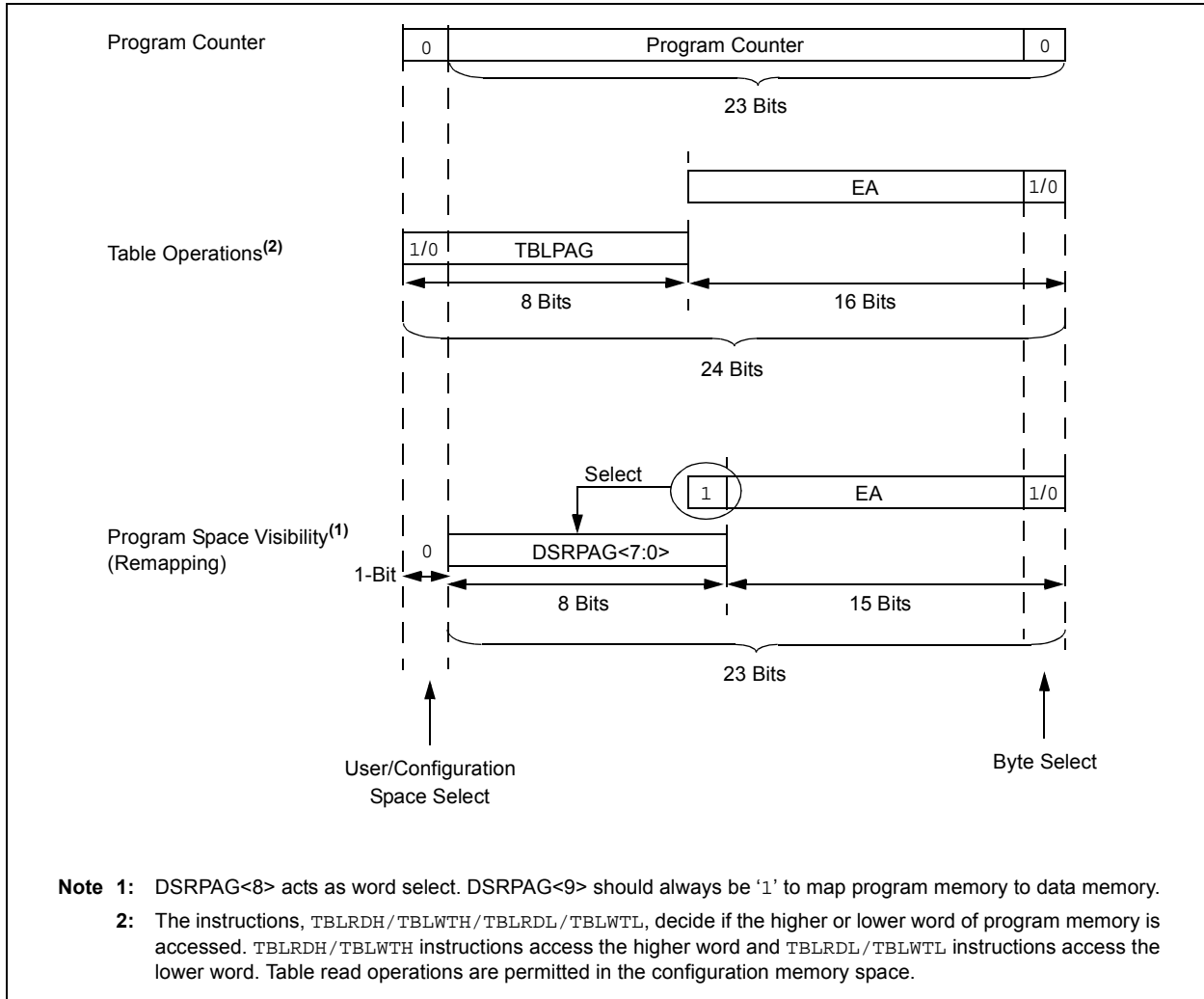

PIC24FJ256DA210 FAMILY

[查询PIC24FJ256DA106供应商](#)

4.3.2 DATA ACCESS FROM PROGRAM MEMORY USING TABLE INSTRUCTIONS

The TBLRDL and TBLWTL instructions offer a direct method of reading or writing the lower word of any address within the program space without going through data space. The TBLRDH and TBLWTH instructions are the only method to read or write the upper 8 bits of a program space word as data.

The PC is incremented by two for each successive 24-bit program word. This allows program memory addresses to directly map to data space addresses. Program memory can thus be regarded as two, 16-bit word-wide address spaces, residing side by side, each with the same address range. TBLRDL and TBLWTL access the space which contains the least significant data word, and TBLRDH and TBLWTH access the space which contains the upper data byte.

Two table instructions are provided to move byte or word-sized (16-bit) data to and from program space. Both function as either byte or word operations.

1. TBLRDL (Table Read Low): In Word mode, it maps the lower word of the program space location ($P<15:0>$) to a data address ($D<15:0>$). In Byte mode, either the upper or lower byte of the lower program word is mapped to the lower byte of a data address. The upper byte is selected when byte select is '1'; the lower byte is selected when it is '0'.

2. TBLRDH (Table Read High): In Word mode, it maps the entire upper word of a program address ($P<23:16>$) to a data address. Note that $D<15:8>$, the 'phantom' byte, will always be '0'. In Byte mode, it maps the upper or lower byte of the program word to $D<7:0>$ of the data address, as above. Note that the data will always be '0' when the upper 'phantom' byte is selected (byte select = 1).

In a similar fashion, two table instructions, TBLWTH and TBLWTL, are used to write individual bytes or words to a program space address. The details of their operation are described in **Section 5.0 "Flash Program Memory"**.

For all table operations, the area of program memory space to be accessed is determined by the Table Memory Page Address register (TBLPAG). TBLPAG covers the entire program memory space of the device, including user and configuration spaces. When $TBLPAG<7> = 0$, the table page is located in the user memory space. When $TBLPAG<7> = 1$, the page is located in configuration space.

Note: Only table read operations will execute in the configuration memory space, where Device IDs are located. Table write operations are not allowed.

FIGURE 4-9: ACCESSING PROGRAM MEMORY WITH TABLE INSTRUCTIONS

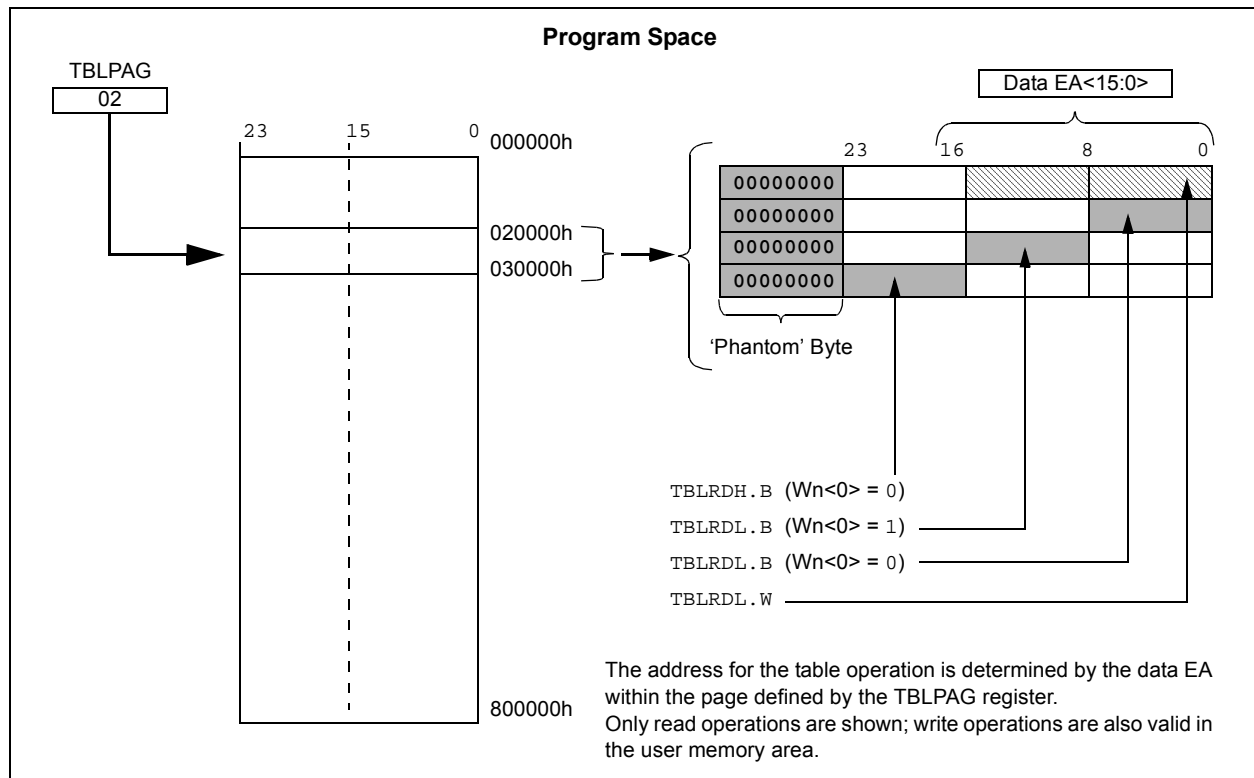

PIC24FJ256DA210 FAMILY

[查询PIC24FJ256DA106供应商](#)

4.3.3 READING DATA FROM PROGRAM MEMORY USING EDS

The upper 32 Kbytes of data space may optionally be mapped into any 16K word page of the program space. This provides transparent access of stored constant data from the data space without the need to use special instructions (i.e., `TBLRDL/H`).

Program space access through the data space occurs when the MSb of EA is '1' and the `DSRPAG<9>` is also '1'. The lower 8 bits of `DSRPAG` are concatenated to the `Wn<14:0>` bits to form a 23-bit EA to access program memory. The `DSRPAG<8>` decides which word should be addressed; when the bit is '0', the lower word and when '1', the upper word of the program memory is accessed.

The entire program memory is divided into 512 EDS pages, from 0x200 to 0x3FF, each consisting of 16K words of data. Pages, 0x200 to 0x2FF, correspond to the lower words of the program memory, while 0x300 to 0x3FF correspond to the upper words of the program memory.

Using this EDS technique, the entire program memory can be accessed. Previously, the access to the upper word of the program memory was not supported.

Table 4-37 provides the corresponding 23-bit EDS address for program memory with EDS page and source addresses.

For operations that use PSV and are executed outside a `REPEAT` loop, the `MOV` and `MOV.D` instructions will require one instruction cycle in addition to the specified execution time. All other instructions will require two instruction cycles in addition to the specified execution time.

For operations that use PSV, which are executed inside a `REPEAT` loop, there will be some instances that require two instruction cycles in addition to the specified execution time of the instruction:

- Execution in the first iteration
- Execution in the last iteration
- Execution prior to exiting the loop due to an interrupt
- Execution upon re-entering the loop after an interrupt is serviced

Any other iteration of the `REPEAT` loop will allow the instruction accessing data, using PSV, to execute in a single cycle.

TABLE 4-37: EDS PROGRAM ADDRESS WITH DIFFERENT PAGES AND ADDRESSES

| DSRPAG (Data Space Read Register) | Source Address while Indirect Addressing | 23-Bit EA Pointing to EDS | Comment |
|--------------------------------------|--|-----------------------------------|---|
| 0x200 | 0x8000 to 0xFFFF | 0x000000 to 0x007FFE | Lower words of 4M program instructions; (8 Mbytes) for read operations only. |
| • | | • | |
| • | | • | |
| 0x2FF | | 0x7F8000 to 0x7FFFFE | Upper words of 4M program instructions (4 Mbytes remaining, 4 Mbytes are phantom bytes) for read operations only. |
| 0x300 | | 0x000001 to 0x007FFF | |
| • | | • | |
| • | | • | |
| • | | • | |
| 0x3FF | 0x7F8001 to 0x7FFFFF | Address error trap ⁽¹⁾ | |
| 0x000 | Invalid Address | | |

Note 1: When the source/destination address is above 0x8000 and `DSRPAG/DSWPAG` is '0', an address error trap will occur.

PIC24FJ256DA210 FAMILY

[查询PIC24FJ256DA106供应商](#)

FIGURE 4-10: PROGRAM SPACE VISIBILITY OPERATION TO ACCESS LOWER WORD

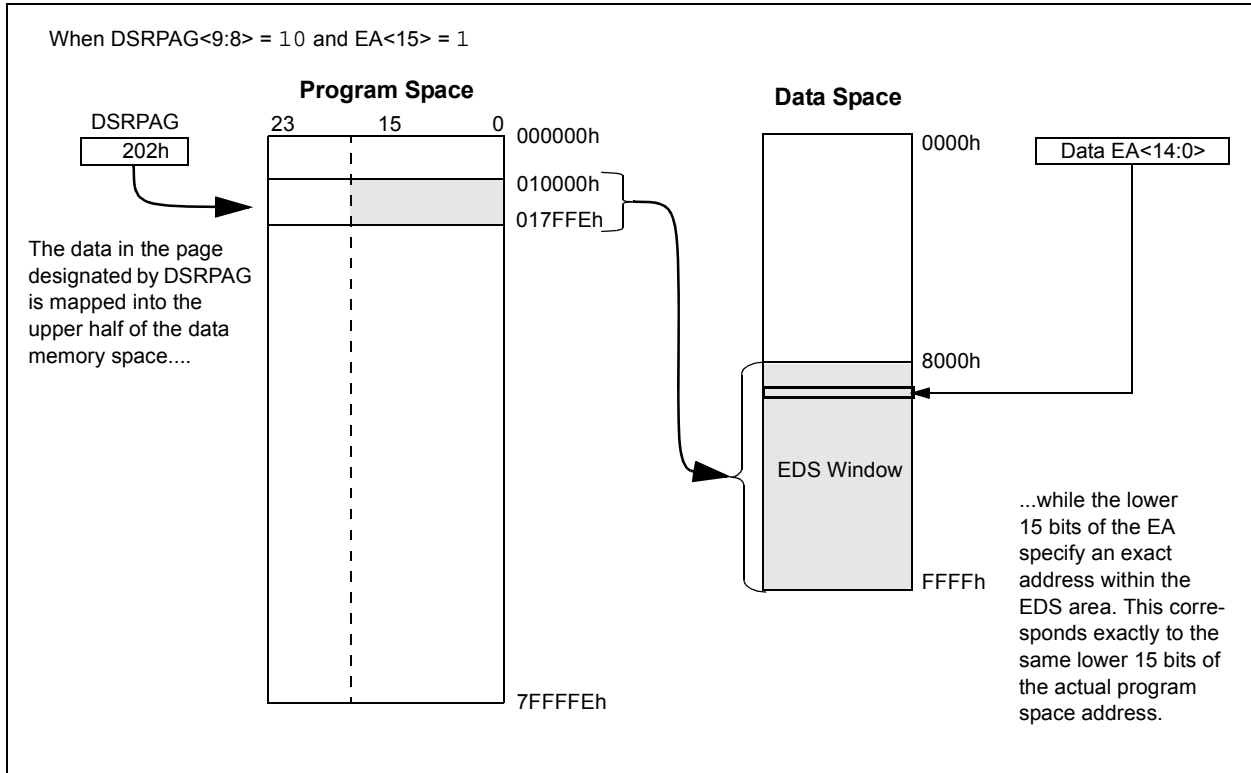
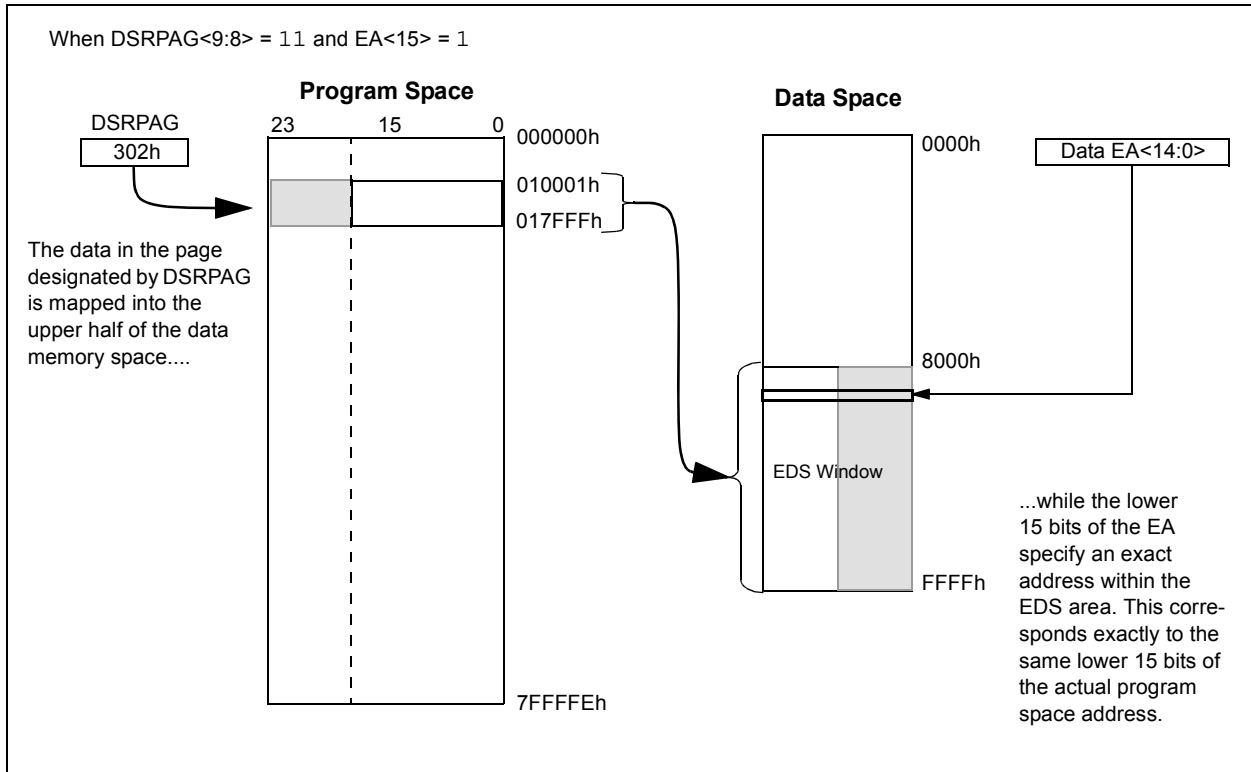

FIGURE 4-11: PROGRAM SPACE VISIBILITY OPERATION TO ACCESS HIGHER WORD



PIC24FJ256DA210 FAMILY

[查询PIC24FJ256DA106供应商](#)

EXAMPLE 4-3: EDS READ CODE FROM PROGRAM MEMORY IN ASSEMBLY

```
; Set the EDS page from where the data to be read
mov    #0x0202 , w0
mov    w0 , DSRPAG           ;page 0x202, consisting lower words, is selected for read
mov    #0x000A , w1         ;select the location (0x0A) to be read
bset   w1 , #15             ;set the MSB of the base address, enable EDS mode

;Read a byte from the selected location
mov.b  [w1++] , w2          ;read Low byte
mov.b  [w1++] , w3          ;read High byte

;Read a word from the selected location
mov    [w1] , w2            ;

;Read Double - word from the selected location
mov.d  [w1] , w2            ;two word read, stored in w2 and w3
```

PIC24FJ256DA210 FAMILY

[查询PIC24FJ256DA106供应商](#)

5.0 FLASH PROGRAM MEMORY

Note: This data sheet summarizes the features of this group of PIC24F devices. It is not intended to be a comprehensive reference source. For more information, refer to the “PIC24F Family Reference Manual”, **Section 4. “Program Memory”** (DS39715). The information in this data sheet supersedes the information in the FRM.

The PIC24FJ256DA210 family of devices contains internal Flash program memory for storing and executing application code. The program memory is readable, writable and erasable. The Flash can be programmed in four ways:

- In-Circuit Serial Programming™ (ICSP™)
- Run-Time Self-Programming (RTSP)
- JTAG
- Enhanced In-Circuit Serial Programming (Enhanced ICSP)

ICSP allows a PIC24FJ256DA210 family device to be serially programmed while in the end application circuit. This is simply done with two lines for the programming clock and programming data (named PGECx and PGEDx, respectively), and three other lines for power (VDD), ground (VSS) and Master Clear (MCLR). This allows customers to manufacture boards with unprogrammed devices and then program the

microcontroller just before shipping the product. This also allows the most recent firmware or a custom firmware to be programmed.

RTSP is accomplished using TBLRD (table read) and TBLWT (table write) instructions. With RTSP, the user may write program memory data in blocks of 64 instructions (192 bytes) at a time and erase program memory in blocks of 512 instructions (1536 bytes) at a time.

5.1 Table Instructions and Flash Programming

Regardless of the method used, all programming of Flash memory is done with the table read and write instructions. These allow direct read and write access to the program memory space from the data memory while the device is in normal operating mode. The 24-bit target address in the program memory is formed using the TBLPAG<7:0> bits and the Effective Address (EA) from a W register, specified in the table instruction, as shown in Figure 5-1.

The TBLRDL and the TBLWTL instructions are used to read or write to bits<15:0> of program memory. TBLRDL and TBLWTL can access program memory in both Word and Byte modes.

The TBLRDH and TBLWTH instructions are used to read or write to bits<23:16> of program memory. TBLRDH and TBLWTH can also access program memory in Word or Byte mode.

FIGURE 5-1: ADDRESSING FOR TABLE REGISTERS

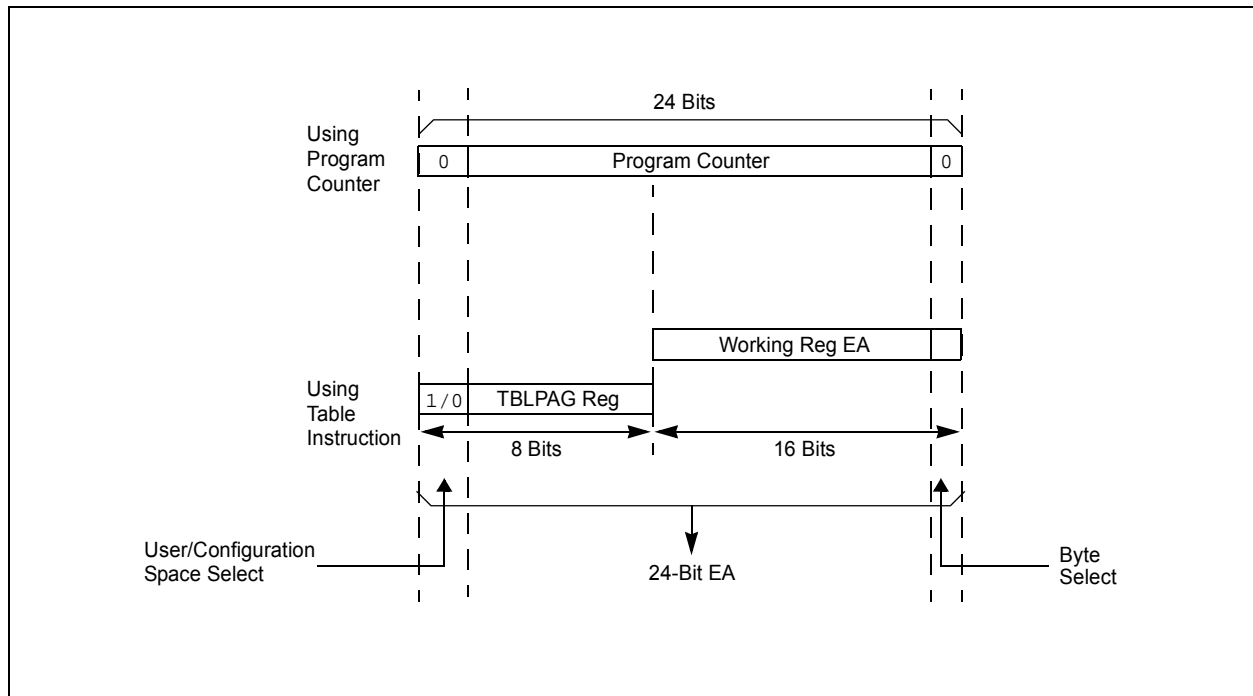

PIC24FJ256DA210 FAMILY

[查询PIC24FJ256DA106供应商](#)

5.2 RTSP Operation

The PIC24F Flash program memory array is organized into rows of 64 instructions or 192 bytes. RTSP allows the user to erase blocks of eight rows (512 instructions) at a time and to program one row at a time. It is also possible to program single words.

The 8-row erase blocks and single row write blocks are edge-aligned, from the beginning of program memory, on boundaries of 1536 bytes and 192 bytes, respectively.

When data is written to program memory using TBLWT instructions, the data is not written directly to memory. Instead, data written using table writes is stored in holding latches until the programming sequence is executed.

Any number of TBLWT instructions can be executed and a write will be successfully performed. However, 64 TBLWT instructions are required to write the full row of memory.

To ensure that no data is corrupted during a write, any unused address should be programmed with FFFFFFFh. This is because the holding latches reset to an unknown state, so if the addresses are left in the Reset state, they may overwrite the locations on rows which were not rewritten.

The basic sequence for RTSP programming is to set up a Table Pointer, then do a series of TBLWT instructions to load the buffers. Programming is performed by setting the control bits in the NVMCON register.

Data can be loaded in any order and the holding registers can be written to multiple times before performing a write operation. Subsequent writes, however, will wipe out any previous writes.

Note: Writing to a location multiple times without erasing is *not* recommended.

All of the table write operations are single-word writes (2 instruction cycles), because only the buffers are written. A programming cycle is required for programming each row.

5.3 JTAG Operation

The PIC24F family supports JTAG boundary scan. Boundary scan can improve the manufacturing process by verifying pin to PCB connectivity.

5.4 Enhanced In-Circuit Serial Programming

Enhanced In-Circuit Serial Programming uses an on-board bootloader, known as the program executive, to manage the programming process. Using an SPI data frame format, the program executive can erase, program and verify program memory. For more information on Enhanced ICSP, see the device programming specification.

5.5 Control Registers

There are two SFRs used to read and write the program Flash memory: NVMCON and NVMKEY.

The NVMCON register (Register 5-1) controls which blocks are to be erased, which memory type is to be programmed and when the programming cycle starts.

NVMKEY is a write-only register that is used for write protection. To start a programming or erase sequence, the user must consecutively write 55h and AAh to the NVMKEY register. Refer to **Section 5.6 “Programming Operations”** for further details.

5.6 Programming Operations

A complete programming sequence is necessary for programming or erasing the internal Flash in RTSP mode. During a programming or erase operation, the processor stalls (waits) until the operation is finished. Setting the WR bit (NVMCON<15>) starts the operation and the WR bit is automatically cleared when the operation is finished.

PIC24FJ256DA210 FAMILY

[查询PIC24FJ256DA106供应商](#)

REGISTER 5-1: NVMCON: FLASH MEMORY CONTROL REGISTER

| | | | | | | | |
|--------------------------|----------------------|-------------------------|-----|-----|-----|-----|-------|
| R/S-0, HC ⁽¹⁾ | R/W-0 ⁽¹⁾ | R-0, HSC ⁽¹⁾ | U-0 | U-0 | U-0 | U-0 | U-0 |
| WR | WREN | WRERR | — | — | — | — | — |
| bit 15 | | | | | | | bit 8 |

| | | | | | | | |
|-------|----------------------|-----|-----|-----------------------|-----------------------|-----------------------|-----------------------|
| U-0 | R/W-0 ⁽¹⁾ | U-0 | U-0 | R/W-0 ⁽¹⁾ | R/W-0 ⁽¹⁾ | R/W-0 ⁽¹⁾ | R/W-0 ⁽¹⁾ |
| — | ERASE | — | — | NVMOP3 ⁽²⁾ | NVMOP2 ⁽²⁾ | NVMOP1 ⁽²⁾ | NVMOP0 ⁽²⁾ |
| bit 7 | | | | | | | bit 0 |

| | | |
|-----------------------------|------------------|---------------------------------------|
| Legend: | S = Settable bit | HSC = Hardware Settable/Clearable bit |
| R = Readable bit | W = Writable bit | U = Unimplemented bit, read as '0' |
| -n = Value at POR | '1' = Bit is set | '0' = Bit is cleared |
| HC = Hardware Clearable bit | | x = Bit is unknown |

- bit 15 **WR:** Write Control bit⁽¹⁾
 1 = Initiates a Flash memory program or erase operation; the operation is self-timed and the bit is cleared by hardware once the operation is complete
 0 = Program or erase operation is complete and inactive
- bit 14 **WREN:** Write Enable bit⁽¹⁾
 1 = Enable Flash program/erase operations
 0 = Inhibit Flash program/erase operations
- bit 13 **WRERR:** Write Sequence Error Flag bit⁽¹⁾
 1 = An improper program or erase sequence attempt or termination has occurred (bit is set automatically on any set attempt of the WR bit)
 0 = The program or erase operation completed normally
- bit 12-7 **Unimplemented:** Read as '0'
- bit 6 **ERASE:** Erase/Program Enable bit⁽¹⁾
 1 = Perform the erase operation specified by NVMOP<3:0> on the next WR command
 0 = Perform the program operation specified by NVMOP<3:0> on the next WR command
- bit 5-4 **Unimplemented:** Read as '0'
- bit 3-0 **NVMOP<3:0>:** NVM Operation Select bits^(1,2)
 1111 = Memory bulk erase operation (ERASE = 1) or no operation (ERASE = 0)⁽³⁾
 0011 = Memory word program operation (ERASE = 0) or no operation (ERASE = 1)
 0010 = Memory page erase operation (ERASE = 1) or no operation (ERASE = 0)
 0001 = Memory row program operation (ERASE = 0) or no operation (ERASE = 1)

- Note 1:** These bits can only be reset on POR.
2: All other combinations of NVMOP<3:0> are unimplemented.
3: Available in ICSP™ mode only; refer to the device programming specification.

PIC24FJ256DA210 FAMILY

[查询PIC24FJ256DA106供应商](#)

5.6.1 PROGRAMMING ALGORITHM FOR FLASH PROGRAM MEMORY

The user can program one row of Flash program memory at a time. To do this, it is necessary to erase the 8-row erase block containing the desired row. The general process is:

1. Read eight rows of program memory (512 instructions) and store in data RAM.
2. Update the program data in RAM with the desired new data.
3. Erase the block (see Example 5-1):
 - a) Set the NVMOP bits (NVMCON<3:0>) to '0010' to configure for block erase. Set the ERASE (NVMCON<6>) and WREN (NVMCON<14>) bits.
 - b) Write the starting address of the block to be erased into the TBLPAG and W registers.
 - c) Write 55h to NVMKEY.
 - d) Write AAh to NVMKEY.
 - e) Set the WR bit (NVMCON<15>). The erase cycle begins and the CPU stalls for the duration of the erase cycle. When the erase is done, the WR bit is cleared automatically.
4. Write the first 64 instructions from data RAM into the program memory buffers (see Example 5-3).
5. Write the program block to Flash memory:
 - a) Set the NVMOP bits to '0001' to configure for row programming. Clear the ERASE bit and set the WREN bit.
 - b) Write 55h to NVMKEY.
 - c) Write AAh to NVMKEY.
 - d) Set the WR bit. The programming cycle begins and the CPU stalls for the duration of the write cycle. When the write to Flash memory is done, the WR bit is cleared automatically.
6. Repeat steps 4 and 5, using the next available 64 instructions from the block in data RAM by incrementing the value in TBLPAG, until all 512 instructions are written back to Flash memory.

For protection against accidental operations, the write initiate sequence for NVMKEY must be used to allow any erase or program operation to proceed. After the programming command has been executed, the user must wait for the programming time until programming is complete. The two instructions following the start of the programming sequence should be NOPs, as shown in Example 5-4.

EXAMPLE 5-1: ERASING A PROGRAM MEMORY BLOCK (ASSEMBLY LANGUAGE CODE)

```
; Set up NVMCON for block erase operation
MOV #0x4042, W0 ;
MOV W0, NVMCON ; Initialize NVMCON
; Init pointer to row to be ERASED
MOV #tblpage(PROG_ADDR), W0 ;
MOV W0, TBLPAG ; Initialize Program Memory (PM) Page Boundary SFR
MOV #tbloffset(PROG_ADDR), W0 ; Initialize in-page EA<15:0> pointer
TBLWTL W0, [W0] ; Set base address of erase block
DISI #5 ; Block all interrupts with priority <7
; for next 5 instructions

MOV.B #0x55, W0
MOV W0, NVMKEY ; Write the 0x55 key
MOV.B #0xAA, W1 ;
MOV W1, NVMKEY ; Write the 0xAA key
BSET NVMCON, #WR ; Start the erase sequence
NOP ; Insert two NOPs after the erase
NOP ; command is asserted
```

PIC24FJ256DA210 FAMILY

[查询PIC24FJ256DA106供应商](#)

EXAMPLE 5-2: ERASING A PROGRAM MEMORY BLOCK ('C' LANGUAGE CODE)

```
// C example using MPLAB C30
unsigned long progAddr = 0XXXXXXX;           // Address of row to write
unsigned int offset;
//Set up pointer to the first memory location to be written
TBLPAG = progAddr>>16;                       // Initialize PM Page Boundary SFR
offset = progAddr & 0xFFFF;                 // Initialize lower word of address
__builtin_tblwtl(offset, 0x0000);           // Set base address of erase block
                                           // with dummy latch write
NVMCON = 0x4042;                             // Initialize NVMCON
asm("DISI #5");                               // Block all interrupts with priority <7
                                           // for next 5 instructions
__builtin_write_NVM();                       // check function to perform unlock
                                           // sequence and set WR
```

EXAMPLE 5-3: LOADING THE WRITE BUFFERS

```
; Set up NVMCON for row programming operations
MOV    #0x4001, W0                          ;
MOV    W0, NVMCON                            ; Initialize NVMCON
; Set up a pointer to the first program memory location to be written
; program memory selected, and writes enabled
MOV    #0x0000, W0                          ;
MOV    W0, TBLPAG                            ; Initialize PM Page Boundary SFR
MOV    #0x6000, W0                          ; An example program memory address
; Perform the TBLWT instructions to write the latches
; 0th_program_word
MOV    #LOW_WORD_0, W2                      ;
MOV    #HIGH_BYTE_0, W3                    ;
TBLWTL W2, [W0]                             ; Write PM low word into program latch
TBLWTH W3, [W0++]                          ; Write PM high byte into program latch
; 1st_program_word
MOV    #LOW_WORD_1, W2                      ;
MOV    #HIGH_BYTE_1, W3                    ;
TBLWTL W2, [W0]                             ; Write PM low word into program latch
TBLWTH W3, [W0++]                          ; Write PM high byte into program latch
; 2nd_program_word
MOV    #LOW_WORD_2, W2                      ;
MOV    #HIGH_BYTE_2, W3                    ;
TBLWTL W2, [W0]                             ; Write PM low word into program latch
TBLWTH W3, [W0++]                          ; Write PM high byte into program latch
.
.
.
; 63rd_program_word
MOV    #LOW_WORD_63, W2                    ;
MOV    #HIGH_BYTE_63, W3                  ;
TBLWTL W2, [W0]                             ; Write PM low word into program latch
TBLWTH W3, [W0]                             ; Write PM high byte into program latch
```

EXAMPLE 5-4: INITIATING A PROGRAMMING SEQUENCE

```
DISI    #5                                  ; Block all interrupts with priority <7
                                           ; for next 5 instructions
MOV.B   #0x55, W0                          ;
MOV     W0, NVMKEY                          ; Write the 0x55 key
MOV.B   #0xAA, W1                          ;
MOV     W1, NVMKEY                          ; Write the 0xAA key
BSET    NVMCON, #WR                         ; Start the programming sequence
NOP                                           ; Required delays
NOP
BTSC    NVMCON, #15                         ; and wait for it to be
BRA     $-2                                  ; completed
```

PIC24FJ256DA210 FAMILY

[查询PIC24FJ256DA106供应商](#)

5.6.2 PROGRAMMING A SINGLE WORD OF FLASH PROGRAM MEMORY

If a Flash location has been erased, it can be programmed using table write instructions to write an instruction word (24-bit) into the write latch. The TBLPAG register is loaded with the 8 Most Significant Bytes (MSB) of the Flash address. The TBLWTL and TBLWTH instructions write the desired data into the

write latches and specify the lower 16 bits of the program memory address to write to. To configure the NVMCON register for a word write, set the NVMOP bits (NVMCON<3:0>) to '0011'. The write is performed by executing the unlock sequence and setting the WR bit (see Example 5-5). An equivalent procedure in 'C' compiler, using the MPLAB C30 compiler and built-in hardware functions is shown in Example 5-6.

EXAMPLE 5-5: PROGRAMMING A SINGLE WORD OF FLASH PROGRAM MEMORY

```
; Setup a pointer to data Program Memory
MOV   #tblpage(PROG_ADDR), W0      ;
MOV   W0, TBLPAG                   ;Initialize PM Page Boundary SFR
MOV   #tbloffset(PROG_ADDR), W0    ;Initialize a register with program memory address

MOV   #LOW_WORD_N, W2              ;
MOV   #HIGH_BYTE_N, W3            ;
TBLWTL W2, [W0]                    ; Write PM low word into program latch
TBLWTH W3, [W0++]                 ; Write PM high byte into program latch

; Setup NVMCON for programming one word to data Program Memory
MOV   #0x4003, W0                  ;
MOV   W0, NVMCON                   ; Set NVMOP bits to 0011

DISI   #5                          ; Disable interrupts while the KEY sequence is written
MOV.B  #0x55, W0                    ; Write the key sequence
MOV   W0, NVMKEY
MOV.B  #0xAA, W0
MOV   W0, NVMKEY
BSET   NVMCON, #WR                 ; Start the write cycle
NOP                                         ; Required delays
NOP
```

EXAMPLE 5-6: PROGRAMMING A SINGLE WORD OF FLASH PROGRAM MEMORY ('C' LANGUAGE CODE)

```
// C example using MPLAB C30
unsigned int offset;
unsigned long progAddr = 0xXXXXXX;      // Address of word to program
unsigned int progDataL = 0xFFFF;       // Data to program lower word
unsigned char progDataH = 0xFF;        // Data to program upper byte

//Set up NVMCON for word programming
NVMCON = 0x4003;                        // Initialize NVMCON

//Set up pointer to the first memory location to be written
TBLPAG = progAddr>>16;                  // Initialize PM Page Boundary SFR
offset = progAddr & 0xFFFF;            // Initialize lower word of address

//Perform TBLWT instructions to write latches
__builtin_tblwtl(offset, progDataL);    // Write to address low word
__builtin_tblwth(offset, progDataH);    // Write to upper byte
asm("DISI #5");                          // Block interrupts with priority <7
// for next 5 instructions
__builtin_write_NVM();                  // C30 function to perform unlock
// sequence and set WR
```

PIC24FJ256DA210 FAMILY

[查询PIC24FJ256DA106供应商](#)

6.0 RESETS

Note: This data sheet summarizes the features of this group of PIC24F devices. It is not intended to be a comprehensive reference source. For more information, refer to the “PIC24F Family Reference Manual”, Section 7. “Reset” (DS39712). The information in this data sheet supersedes the information in the FRM.

The Reset module combines all Reset sources and controls the device Master Reset Signal, $\overline{\text{SYSRST}}$. The following is a list of device Reset sources:

- POR: Power-on Reset
- $\overline{\text{MCLR}}$: Pin Reset
- SWR: RESET Instruction
- WDT: Watchdog Timer Reset
- BOR: Brown-out Reset
- CM: Configuration Mismatch Reset
- TRAPR: Trap Conflict Reset
- IOPUWR: Illegal Opcode Reset
- UWR: Uninitialized W Register Reset

A simplified block diagram of the Reset module is shown in Figure 6-1.

Any active source of Reset will make the $\overline{\text{SYSRST}}$ signal active. Many registers associated with the CPU and peripherals are forced to a known Reset state. Most registers are unaffected by a Reset; their status is unknown on POR and unchanged by all other Resets.

Note: Refer to the specific peripheral or CPU section of this manual for register Reset states.

All types of device Reset will set a corresponding status bit in the RCON register to indicate the type of Reset (see Register 6-1). A POR will clear all bits, except for the BOR and POR (RCON<1:0>) bits, which are set. The user may set or clear any bit at any time during code execution. The RCON bits only serve as status bits. Setting a particular Reset status bit in software will not cause a device Reset to occur.

The RCON register also has other bits associated with the Watchdog Timer and device power-saving states. The function of these bits is discussed in other sections of this data sheet.

Note: The status bits in the RCON register should be cleared after they are read so that the next RCON register value after a device Reset will be meaningful.

FIGURE 6-1: RESET SYSTEM BLOCK DIAGRAM

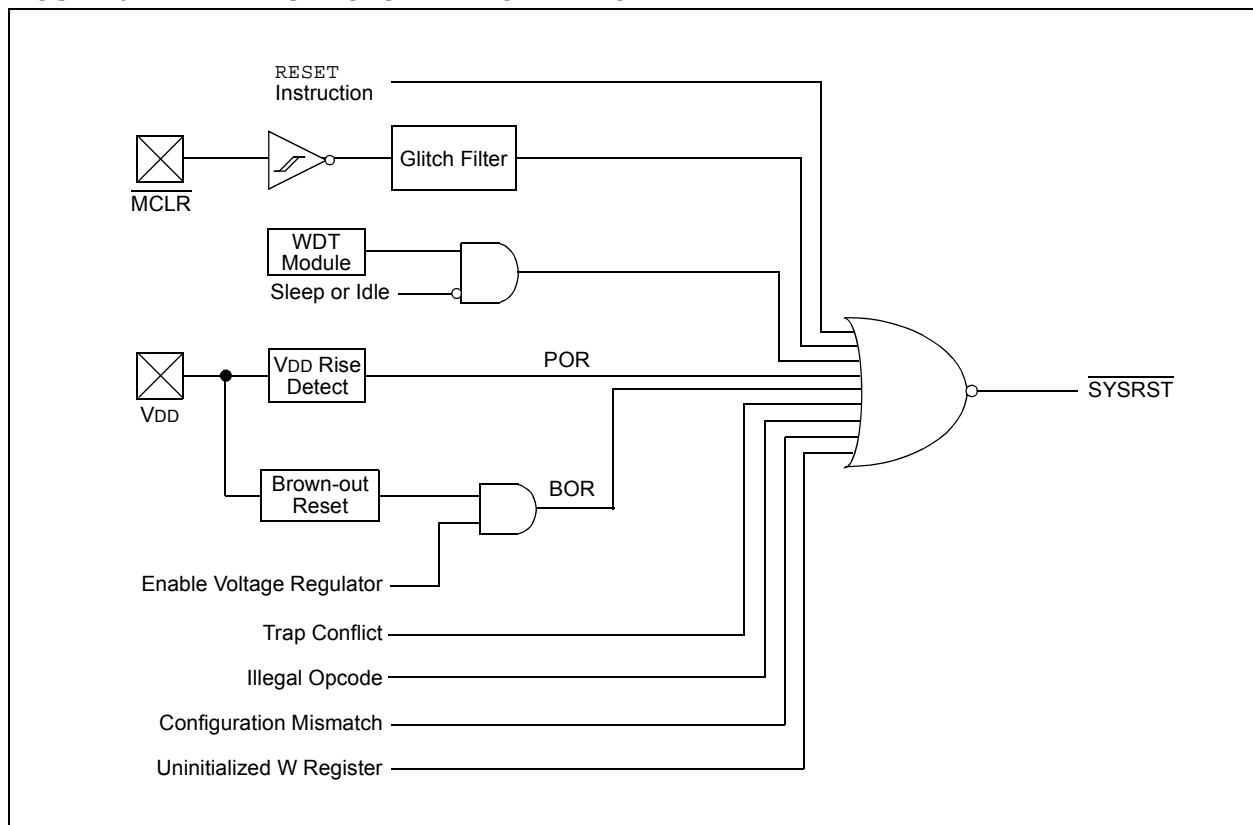

PIC24FJ256DA210 FAMILY

[查询PIC24FJ256DA106供应商](#)

REGISTER 6-1: RCON: RESET CONTROL REGISTER⁽¹⁾

| | | | | | | | |
|-----------|-----------|-----|-----|-----|-----|-----------|----------------------|
| R/W-0, HS | R/W-0, HS | U-0 | U-0 | U-0 | U-0 | R/W-0, HS | R/W-0 |
| TRAPR | IOPUWR | — | — | — | — | CM | VREGS ⁽³⁾ |
| bit 15 | | | | | | | bit 8 |

| | | | | | | | |
|-----------|-----------|-----------------------|-----------|-----------|-----------|-----------|-----------|
| R/W-0, HS | R/W-0, HS | R/W-0, HS | R/W-0, HS | R/W-0, HS | R/W-0, HS | R/W-1, HS | R/W-1, HS |
| EXTR | SWR | SWDTEN ⁽²⁾ | WDTO | SLEEP | IDLE | BOR | POR |
| bit 7 | | | | | | | bit 0 |

| | | | |
|-------------------|----------------------------|------------------------------------|--------------------|
| Legend: | HS = Hardware Settable bit | | |
| R = Readable bit | W = Writable bit | U = Unimplemented bit, read as '0' | |
| -n = Value at POR | '1' = Bit is set | '0' = Bit is cleared | x = Bit is unknown |

- bit 15 **TRAPR:** Trap Reset Flag bit
 1 = A Trap Conflict Reset has occurred
 0 = A Trap Conflict Reset has not occurred
- bit 14 **IOPUWR:** Illegal Opcode or Uninitialized W Access Reset Flag bit
 1 = An illegal opcode detection, an illegal address mode or uninitialized W register is used as an Address Pointer and caused a Reset
 0 = An illegal opcode or uninitialized W Reset has not occurred
- bit 13-10 **Unimplemented:** Read as '0'
- bit 9 **CM:** Configuration Word Mismatch Reset Flag bit
 1 = A Configuration Word Mismatch Reset has occurred
 0 = A Configuration Word Mismatch Reset has not occurred
- bit 8 **VREGS:** Voltage Regulator Standby Enable bit⁽³⁾
 1 = Program memory and regulator remain active during Sleep/Idle
 0 = Program memory power is removed and regulator goes to standby during Seep/Idle
- bit 7 **EXTR:** External Reset ($\overline{\text{MCLR}}$) Pin bit
 1 = A Master Clear (pin) Reset has occurred
 0 = A Master Clear (pin) Reset has not occurred
- bit 6 **SWR:** Software Reset (Instruction) Flag bit
 1 = A RESET instruction has been executed
 0 = A RESET instruction has not been executed
- bit 5 **SWDTEN:** Software Enable/Disable of WDT bit⁽²⁾
 1 = WDT is enabled
 0 = WDT is disabled
- bit 4 **WDTO:** Watchdog Timer Time-out Flag bit
 1 = WDT time-out has occurred
 0 = WDT time-out has not occurred
- bit 3 **SLEEP:** Wake From Sleep Flag bit
 1 = Device has been in Sleep mode
 0 = Device has not been in Sleep mode

- Note 1:** All of the Reset status bits may be set or cleared in software. Setting one of these bits in software does not cause a device Reset.
- 2:** If the FWDTEN Configuration bit is '1' (unprogrammed), the WDT is always enabled, regardless of the SWDTEN bit setting.
- 3:** Re-enabling the regulator after it enters Standby mode will add a delay, TVREG, when waking up from Sleep. Applications that do not use the voltage regulator should set this bit to prevent this delay from occurring.

PIC24FJ256DA210 FAMILY

[查询PIC24FJ256DA106供应商](#)

REGISTER 6-1: RCON: RESET CONTROL REGISTER⁽¹⁾ (CONTINUED)

- bit 2 **IDLE:** Wake-up From Idle Flag bit
 1 = Device has been in Idle mode
 0 = Device has not been in Idle mode
- bit 1 **BOR:** Brown-out Reset Flag bit
 1 = A Brown-out Reset has occurred
 Note that BOR is also set after a Power-on Reset.
 0 = A Brown-out Reset has not occurred
- bit 0 **POR:** Power-on Reset Flag bit
 1 = A Power-on Reset has occurred
 0 = A Power-on Reset has not occurred

- Note 1:** All of the Reset status bits may be set or cleared in software. Setting one of these bits in software does not cause a device Reset.
- 2:** If the FWDTEN Configuration bit is '1' (unprogrammed), the WDT is always enabled, regardless of the SWDTEN bit setting.
- 3:** Re-enabling the regulator after it enters Standby mode will add a delay, TVREG, when waking up from Sleep. Applications that do not use the voltage regulator should set this bit to prevent this delay from occurring.

TABLE 6-1: RESET FLAG BIT OPERATION

| Flag Bit | Setting Event | Clearing Event |
|-------------------|---|---------------------------------|
| TRAPR (RCON<15>) | Trap Conflict Event | POR |
| IOPUWR (RCON<14>) | Illegal Opcode or Uninitialized W Register Access | POR |
| CM (RCON<9>) | Configuration Mismatch Reset | POR |
| EXTR (RCON<7>) | MCLR Reset | POR |
| SWR (RCON<6>) | RESET Instruction | POR |
| WDTO (RCON<4>) | WDT Time-out | CLRWDT, PWRSAV Instruction, POR |
| SLEEP (RCON<3>) | PWRSAV #0 Instruction | POR |
| IDLE (RCON<2>) | PWRSAV #1 Instruction | POR |
| BOR (RCON<1>) | POR, BOR | — |
| POR (RCON<0>) | POR | — |

Note: All Reset flag bits may be set or cleared by the user software.

PIC24FJ256DA210 FAMILY

查询PIC24FJ256DA106供应商

6.1 Special Function Register Reset States

Most of the Special Function Registers (SFRs) associated with the PIC24F CPU and peripherals are reset to a particular value at a device Reset. The SFRs are grouped by their peripheral or CPU function and their Reset values are specified in each section of this manual.

The Reset value for each SFR does not depend on the type of Reset, with the exception of four registers. The Reset value for the Reset Control register, RCON, will depend on the type of device Reset. The Reset value for the Oscillator Control register, OSCCON, will depend on the type of Reset and the programmed values of the FNOSC bits in Flash Configuration Word 2 (CW2) (see Table 6-2). The RCFGAL and NVMCON registers are only affected by a POR.

6.2 Device Reset Times

The Reset times for various types of device Reset are summarized in Table 6-3. Note that the system Reset signal, $\overline{\text{SYSRST}}$, is released after the POR delay time expires.

The time at which the device actually begins to execute code will also depend on the system oscillator delays, which include the Oscillator Start-up Timer (OST) and the PLL lock time. The OST and PLL lock times occur in parallel with the applicable $\overline{\text{SYSRST}}$ delay times.

The Fail-Safe Clock Monitor (FSCM) delay determines the time at which the FSCM begins to monitor the system clock source after the $\overline{\text{SYSRST}}$ signal is released.

6.3 Clock Source Selection at Reset

If clock switching is enabled, the system clock source at device Reset is chosen, as shown in Table 6-2. If clock switching is disabled, the system clock source is always selected according to the oscillator Configuration bits. Refer to the "PIC24F Family Reference Manual", Section 8.0 "Oscillator Configuration" for further details.

TABLE 6-2: OSCILLATOR SELECTION vs. TYPE OF RESET (CLOCK SWITCHING ENABLED)

| Reset Type | Clock Source Determinant |
|--------------------------|---|
| POR | FNOSC Configuration bits (CW2<10:8>) |
| BOR | |
| $\overline{\text{MCLR}}$ | COSC Control bits (OSCCON<14:12>) |
| WDTO | |
| SWR | |

PIC24FJ256DA210 FAMILY

[查询PIC24FJ256DA106供应商](#)

TABLE 6-3: RESET DELAY TIMES FOR VARIOUS DEVICE RESETS

| Reset Type | Clock Source | $\overline{\text{SYSRST}}$ Delay | System Clock Delay | Notes |
|--------------------|--------------|----------------------------------|--------------------|---------------|
| POR ⁽⁷⁾ | EC | TPOR + TSTARTUP + TRST | — | 1, 2, 3 |
| | ECPLL | TPOR + TSTARTUP + TRST | TLOCK | 1, 2, 3, 5 |
| | XT, HS, SOSC | TPOR + TSTARTUP + TRST | TOST | 1, 2, 3, 4 |
| | XTPLL, HSPLL | TPOR + TSTARTUP + TRST | TOST + TLOCK | 1, 2, 3, 4, 5 |
| | FRC, FRCDIV | TPOR + TSTARTUP + TRST | TFRC | 1, 2, 3, 6, 7 |
| | FRCPLL | TPOR + TSTARTUP + TRST | TFRC + TLOCK | 1, 2, 3, 5, 6 |
| | LPRC | TPOR + TSTARTUP + TRST | TLPRC | 1, 2, 3, 6 |
| BOR | EC | TSTARTUP + TRST | — | 2, 3 |
| | ECPLL | TSTARTUP + TRST | TLOCK | 2, 3, 5 |
| | XT, HS, SOSC | TSTARTUP + TRST | TOST | 2, 3, 4 |
| | XTPLL, HSPLL | TSTARTUP + TRST | TOST + TLOCK | 2, 3, 4, 5 |
| | FRC, FRCDIV | TSTARTUP + TRST | TFRC | 2, 3, 6, 7 |
| | FRCPLL | TSTARTUP + TRST | TFRC + TLOCK | 2, 3, 5, 6 |
| | LPRC | TSTARTUP + TRST | TLPRC | 2, 3, 6 |
| MCLR | Any Clock | TRST | — | 3 |
| WDT | Any Clock | TRST | — | 3 |
| Software | Any clock | TRST | — | 3 |
| Illegal Opcode | Any Clock | TRST | — | 3 |
| Uninitialized W | Any Clock | TRST | — | 3 |
| Trap Conflict | Any Clock | TRST | — | 3 |

Note 1: TPOR = Power-on Reset delay (10 μ s nominal).

2: TSTARTUP = TVREG (10 μ s nominal when VREGS = 1 and when VREGS = 0; depends upon WUTSEL<1:0> bits setting).

3: TRST = Internal State Reset time (32 μ s nominal).

4: TOST = Oscillator Start-up Timer. A 10-bit counter counts 1024 oscillator periods before releasing the oscillator clock to the system.

5: TLOCK = PLL lock time.

6: TFRC and TLPRC = RC Oscillator start-up times.

7: If Two-speed Start-up is enabled, regardless of the primary oscillator selected, the device starts with FRC so the system clock delay is just TFRC, and in such cases, FRC start-up time is valid. It switches to the primary oscillator after its respective clock delay.

6.3.1 POR AND LONG OSCILLATOR START-UP TIMES

The oscillator start-up circuitry and its associated delay timers are not linked to the device Reset delays that occur at power-up. Some crystal circuits (especially low-frequency crystals) will have a relatively long start-up time. Therefore, one or more of the following conditions is possible after $\overline{\text{SYSRST}}$ is released:

- The oscillator circuit has not begun to oscillate.
- The Oscillator Start-up Timer has not expired (if a crystal oscillator is used).
- The PLL has not achieved a lock (if PLL is used).

The device will not begin to execute code until a valid clock source has been released to the system. Therefore, the oscillator and PLL start-up delays must be considered when the Reset delay time must be known.

6.3.2 FAIL-SAFE CLOCK MONITOR (FSCM) AND DEVICE RESETS

If the FSCM is enabled, it will begin to monitor the system clock source when $\overline{\text{SYSRST}}$ is released. If a valid clock source is not available at this time, the device will automatically switch to the FRC oscillator and the user can switch to the desired crystal oscillator in the Trap Service Routine (TSR).

PIC24FJ256DA210 FAMILY

[查询PIC24FJ256DA106供应商](#)

NOTES:

PIC24FJ256DA210 FAMILY

[查询PIC24FJ256DA106供应商](#)

7.0 INTERRUPT CONTROLLER

Note: This data sheet summarizes the features of this group of PIC24F devices. It is not intended to be a comprehensive reference source. For more information, refer to the “PIC24F Family Reference Manual”, **Section 8. “Interrupts”** (DS39707). The information in this data sheet supersedes the information in the FRM.

The PIC24F interrupt controller reduces the numerous peripheral interrupt request signals to a single interrupt request signal to the PIC24F CPU. It has the following features:

- Up to 8 processor exceptions and software traps
- Seven user-selectable priority levels
- Interrupt Vector Table (IVT) with up to 118 vectors
- Unique vector for each interrupt or exception source
- Fixed priority within a specified user priority level
- Alternate Interrupt Vector Table (AIVT) for debug support
- Fixed interrupt entry and return latencies

7.1 Interrupt Vector Table

The Interrupt Vector Table (IVT) is shown in Figure 7-1. The IVT resides in program memory, starting at location 000004h. The IVT contains 126 vectors, consisting of 8 non-maskable trap vectors, plus up to 118 sources of interrupt. In general, each interrupt source has its own vector. Each interrupt vector contains a 24-bit wide address. The value programmed into each interrupt vector location is the starting address of the associated Interrupt Service Routine (ISR).

Interrupt vectors are prioritized in terms of their natural priority; this is linked to their position in the vector table. All other things being equal, lower addresses have a higher natural priority. For example, the interrupt associated with Vector 0 will take priority over interrupts at any other vector address.

PIC24FJ256DA210 family devices implement non-maskable traps and unique interrupts. These are summarized in Table 7-1 and Table 7-2.

7.1.1 ALTERNATE INTERRUPT VECTOR TABLE

The Alternate Interrupt Vector Table (AIVT) is located after the IVT, as shown in Figure 7-1. The ALTIVT (INTCON2<15>) control bit provides access to the AIVT. If the ALTIVT bit is set, all interrupt and exception processes will use the alternate vectors instead of the default vectors. The alternate vectors are organized in the same manner as the default vectors.

The AIVT supports emulation and debugging efforts by providing a means to switch between an application and a support environment without requiring the interrupt vectors to be reprogrammed. This feature also enables switching between applications for evaluation of different software algorithms at run time. If the AIVT is not needed, the AIVT should be programmed with the same addresses used in the IVT.

7.2 Reset Sequence

A device Reset is not a true exception because the interrupt controller is not involved in the Reset process. The PIC24F devices clear their registers in response to a Reset, which forces the PC to zero. The microcontroller then begins program execution at location, 000000h. The user programs a GOTO instruction at the Reset address, which redirects program execution to the appropriate start-up routine.

Note: Any unimplemented or unused vector locations in the IVT and AIVT should be programmed with the address of a default interrupt handler routine that contains a RESET instruction.

PIC24FJ256DA210 FAMILY

查询PIC24FJ256DA106供应商

FIGURE 7-1: PIC24F INTERRUPT VECTOR TABLE

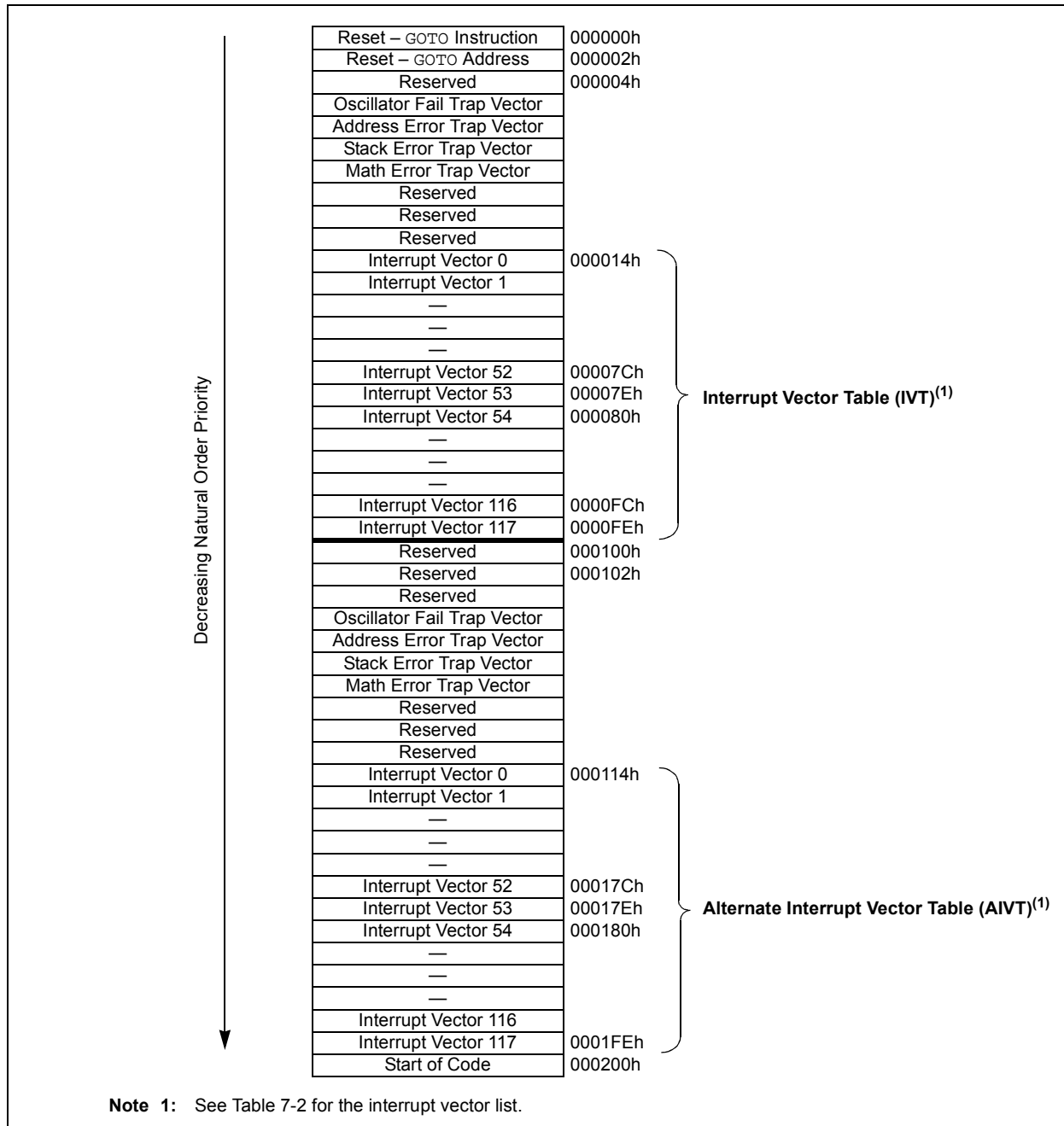

TABLE 7-1: TRAP VECTOR DETAILS

| Vector Number | IVT Address | AIVT Address | Trap Source |
|---------------|-------------|--------------|--------------------|
| 0 | 000004h | 000104h | Reserved |
| 1 | 000006h | 000106h | Oscillator Failure |
| 2 | 000008h | 000108h | Address Error |
| 3 | 00000Ah | 00010Ah | Stack Error |
| 4 | 00000Ch | 00010Ch | Math Error |
| 5 | 00000Eh | 00010Eh | Reserved |
| 6 | 000010h | 000110h | Reserved |
| 7 | 000012h | 000112h | Reserved |

PIC24FJ256DA210 FAMILY

查询PIC24FJ256DA106供应商

TABLE 7-2: IMPLEMENTED INTERRUPT VECTORS

| Interrupt Source | Vector Number | IVT Address | AIVT Address | Interrupt Bit Locations | | |
|---|---------------|-------------|--------------|-------------------------|----------|--------------|
| | | | | Flag | Enable | Priority |
| ADC1 Conversion Done | 13 | 00002Eh | 00012Eh | IFS0<13> | IEC0<13> | IPC3<6:4> |
| Comparator Event | 18 | 000038h | 000138h | IFS1<2> | IEC1<2> | IPC4<10:8> |
| CRC Generator | 67 | 00009Ah | 00019Ah | IFS4<3> | IEC4<3> | IPC16<14:12> |
| CTMU Event | 77 | 0000AEh | 0001AEh | IFS4<13> | IEC4<13> | IPC19<6:4> |
| External Interrupt 0 | 0 | 000014h | 000114h | IFS0<0> | IEC0<0> | IPC0<2:0> |
| External Interrupt 1 | 20 | 00003Ch | 00013Ch | IFS1<4> | IEC1<4> | IPC5<2:0> |
| External Interrupt 2 | 29 | 00004Eh | 00014Eh | IFS1<13> | IEC1<13> | IPC7<6:4> |
| External Interrupt 3 | 53 | 00007Eh | 00017Eh | IFS3<5> | IEC3<5> | IPC13<6:4> |
| External Interrupt 4 | 54 | 000080h | 000180h | IFS3<6> | IEC3<6> | IPC13<10:8> |
| Graphics Controller | 100 | 0000DCh | 0001DCh | IFS6<4> | IEC6<4> | IPC25<2:0> |
| I2C1 Master Event | 17 | 000036h | 000136h | IFS1<1> | IEC1<1> | IPC4<6:4> |
| I2C1 Slave Event | 16 | 000034h | 000134h | IFS1<0> | IEC1<0> | IPC4<2:0> |
| I2C2 Master Event | 50 | 000078h | 000178h | IFS3<2> | IEC3<2> | IPC12<10:8> |
| I2C2 Slave Event | 49 | 000076h | 000176h | IFS3<1> | IEC3<1> | IPC12<6:4> |
| I2C3 Master Event | 85 | 0000BEh | 0001BEh | IFS5<5> | IEC5<5> | IPC21<6:4> |
| I2C3 Slave Event | 84 | 0000BCh | 0001BCh | IFS5<4> | IEC5<4> | IPC21<2:0> |
| Input Capture 1 | 1 | 000016h | 000116h | IFS0<1> | IEC0<1> | IPC0<6:4> |
| Input Capture 2 | 5 | 00001Eh | 00011Eh | IFS0<5> | IEC0<5> | IPC1<6:4> |
| Input Capture 3 | 37 | 00005Eh | 00015Eh | IFS2<5> | IEC2<5> | IPC9<6:4> |
| Input Capture 4 | 38 | 000060h | 000160h | IFS2<6> | IEC2<6> | IPC9<10:8> |
| Input Capture 5 | 39 | 000062h | 000162h | IFS2<7> | IEC2<7> | IPC9<14:12> |
| Input Capture 6 | 40 | 000064h | 000164h | IFS2<8> | IEC2<8> | IPC10<2:0> |
| Input Capture 7 | 22 | 000040h | 000140h | IFS1<6> | IEC1<6> | IPC5<10:8> |
| Input Capture 8 | 23 | 000042h | 000142h | IFS1<7> | IEC1<7> | IPC5<14:12> |
| Input Capture 9 | 93 | 0000CEh | 0001CEh | IFS5<13> | IEC5<13> | IPC23<6:4> |
| Input Change Notification (ICN) | 19 | 00003Ah | 00013Ah | IFS1<3> | IEC1<3> | IPC4<14:12> |
| Low-Voltage Detect (LVD) | 72 | 0000A4h | 0001A4h | IFS4<8> | IEC4<8> | IPC18<2:0> |
| Output Compare 1 | 2 | 000018h | 000118h | IFS0<2> | IEC0<2> | IPC0<10:8> |
| Output Compare 2 | 6 | 000020h | 000120h | IFS0<6> | IEC0<6> | IPC1<10:8> |
| Output Compare 3 | 25 | 000046h | 000146h | IFS1<9> | IEC1<9> | IPC6<6:4> |
| Output Compare 4 | 26 | 000048h | 000148h | IFS1<10> | IEC1<10> | IPC6<10:8> |
| Output Compare 5 | 41 | 000066h | 000166h | IFS2<9> | IEC2<9> | IPC10<6:4> |
| Output Compare 6 | 42 | 000068h | 000168h | IFS2<10> | IEC2<10> | IPC10<10:8> |
| Output Compare 7 | 43 | 00006Ah | 00016Ah | IFS2<11> | IEC2<11> | IPC10<14:12> |
| Output Compare 8 | 44 | 00006Ch | 00016Ch | IFS2<12> | IEC2<12> | IPC11<2:0> |
| Output Compare 9 | 92 | 0000CCh | 0001CCh | IFS5<12> | IEC5<12> | IPC23<2:0> |
| Enhanced Parallel Master Port (EPMP) ⁽¹⁾ | 45 | 00006Eh | 00016Eh | IFS2<13> | IEC2<13> | IPC11<6:4> |
| Real-Time Clock and Calendar (RTCC) | 62 | 000090h | 000190h | IFS3<14> | IEC3<14> | IPC15<10:8> |
| SPI1 Error | 9 | 000026h | 000126h | IFS0<9> | IEC0<9> | IPC2<6:4> |
| SPI1 Event | 10 | 000028h | 000128h | IFS0<10> | IEC0<10> | IPC2<10:8> |
| SPI2 Error | 32 | 000054h | 000154h | IFS2<0> | IEC2<0> | IPC8<2:0> |
| SPI2 Event | 33 | 000056h | 000156h | IFS2<1> | IEC2<1> | IPC8<6:4> |
| SPI3 Error | 90 | 0000C8h | 0001C8h | IFS5<10> | IEC5<10> | IPC22<10:8> |
| SPI3 Event | 91 | 0000CAh | 0001CAh | IFS5<11> | IEC5<11> | IPC22<14:12> |

Note 1: Not available in 64-pin devices (PIC24FJXXXDAX06).

PIC24FJ256DA210 FAMILY

[查询PIC24FJ256DA106供应商](#)

TABLE 7-2: IMPLEMENTED INTERRUPT VECTORS (CONTINUED)

| Interrupt Source | Vector Number | IVT Address | AIVT Address | Interrupt Bit Locations | | |
|-------------------|---------------|-------------|--------------|-------------------------|----------|--------------|
| | | | | Flag | Enable | Priority |
| Timer1 | 3 | 00001Ah | 00011Ah | IFS0<3> | IEC0<3> | IPC0<14:12> |
| Timer2 | 7 | 000022h | 000122h | IFS0<7> | IEC0<7> | IPC1<14:12> |
| Timer3 | 8 | 000024h | 000124h | IFS0<8> | IEC0<8> | IPC2<2:0> |
| Timer4 | 27 | 00004Ah | 00014Ah | IFS1<11> | IEC1<11> | IPC6<14:12> |
| Timer5 | 28 | 00004Ch | 00014Ch | IFS1<12> | IEC1<12> | IPC7<2:0> |
| UART1 Error | 65 | 000096h | 000196h | IFS4<1> | IEC4<1> | IPC16<6:4> |
| UART1 Receiver | 11 | 00002Ah | 00012Ah | IFS0<11> | IEC0<11> | IPC2<14:12> |
| UART1 Transmitter | 12 | 00002Ch | 00012Ch | IFS0<12> | IEC0<12> | IPC3<2:0> |
| UART2 Error | 66 | 000098h | 000198h | IFS4<2> | IEC4<2> | IPC16<10:8> |
| UART2 Receiver | 30 | 000050h | 000150h | IFS1<14> | IEC1<14> | IPC7<10:8> |
| UART2 Transmitter | 31 | 000052h | 000152h | IFS1<15> | IEC1<15> | IPC7<14:12> |
| UART3 Error | 81 | 0000B6h | 0001B6h | IFS5<1> | IEC5<1> | IPC20<6:4> |
| UART3 Receiver | 82 | 0000B8h | 0001B8h | IFS5<2> | IEC5<2> | IPC20<10:8> |
| UART3 Transmitter | 83 | 0000BAh | 0001BAh | IFS5<3> | IEC5<3> | IPC20<14:12> |
| UART4 Error | 87 | 0000C2h | 0001C2h | IFS5<7> | IEC5<7> | IPC21<14:12> |
| UART4 Receiver | 88 | 0000C4h | 0001C4h | IFS5<8> | IEC5<8> | IPC22<2:0> |
| UART4 Transmitter | 89 | 0000C6h | 0001C6h | IFS5<9> | IEC5<9> | IPC22<6:4> |
| USB Interrupt | 86 | 0000C0h | 0001C0h | IFS5<6> | IEC5<6> | IPC21<10:8> |

Note 1: Not available in 64-pin devices (PIC24FJXXXDAX06).

7.3 Interrupt Control and Status Registers

The PIC24FJ256DA210 family of devices implements a total of 40 registers for the interrupt controller:

- INTCON1
- INTCON2
- IFS0 through IFS6
- IEC0 through IEC6
- IPC0 through IPC25 (except IPC14, IPC17 and IPC24)
- INTTREG

Global interrupt control functions are controlled from INTCON1 and INTCON2. INTCON1 contains the Interrupt Nesting Disable (NSTDIS) bit, as well as the control and status flags for the processor trap sources. The INTCON2 register controls the external interrupt request signal behavior and the use of the Alternate Interrupt Vector Table (AIVT).

The IFSx registers maintain all of the interrupt request flags. Each source of interrupt has a status bit, which is set by the respective peripherals or an external signal and is cleared via software.

The IECx registers maintain all of the interrupt enable bits. These control bits are used to individually enable interrupts from the peripherals or external signals.

The IPCx registers are used to set the interrupt priority level for each source of interrupt. Each user interrupt source can be assigned to one of eight priority levels.

The INTTREG register contains the associated interrupt vector number and the new CPU interrupt priority level, which are latched into the Vector Number (VECNUM<6:0>) and the Interrupt Level (ILR<3:0>) bit fields in the INTTREG register. The new interrupt priority level is the priority of the pending interrupt.

The interrupt sources are assigned to the IFSx, IECx and IPCx registers in the order of their vector numbers, as shown in Table 7-2. For example, the INT0 (External Interrupt 0) is shown as having a vector number and a natural order priority of 0. Thus, the INTOIF status bit is found in IFS0<0>, the INTOIE enable bit in IEC0<0> and the INTOIP<2:0> priority bits in the first position of IPC0 (IPC0<2:0>).

Although they are not specifically part of the interrupt control hardware, two of the CPU Control registers contain bits that control interrupt functionality. The ALU STATUS register (SR) contains the IPL<2:0> bits (SR<7:5>). These indicate the current CPU interrupt priority level. The user can change the current CPU priority level by writing to the IPL bits.

PIC24FJ256DA210 FAMILY

[查询PIC24FJ256DA106供应商](#)

The CORCON register contains the IPL3 bit, which, together with IPL<2:0>, indicates the current CPU priority level. IPL3 is a read-only bit so that trap events cannot be masked by the user software.

The interrupt controller has the Interrupt Controller Test register, INTTREG, which displays the status of the interrupt controller. When an interrupt request occurs, it's associated vector number and the new interrupt priority level are latched into INTTREG. This information can be used to determine a specific interrupt source if

a generic ISR is used for multiple vectors (such as when ISR remapping is used in bootloader applications) or to check if another interrupt is pending while in an ISR.

All interrupt registers are described in Register 7-1 through Register 7-40 in the succeeding pages.

REGISTER 7-1: SR: ALU STATUS REGISTER (IN CPU)

| | | | | | | | |
|--------|-----|-----|-----|-----|-----|-----|-------------------|
| U-0 | U-0 | U-0 | U-0 | U-0 | U-0 | U-0 | R-0, HSC |
| — | — | — | — | — | — | — | DC ⁽¹⁾ |
| bit 15 | | | | | | | bit 8 |

| | | | | | | | |
|-----------------------------------|-----------------------------------|-----------------------------------|-------------------|------------------|-------------------|------------------|------------------|
| R/W-0, HSC | R/W-0, HSC | R/W-0, HSC | R-0, HSC | R/W-0, HSC | R/W-0, HSC | R/W-0, HSC | R/W-0, HSC |
| IPL ₂ ^(2,3) | IPL ₁ ^(2,3) | IPL ₀ ^(2,3) | RA ⁽¹⁾ | N ⁽¹⁾ | OV ⁽¹⁾ | Z ⁽¹⁾ | C ⁽¹⁾ |
| bit 7 | | | | | | | bit 0 |

| | |
|-------------------|---------------------------------------|
| Legend: | HSC = Hardware Settable/Clearable bit |
| R = Readable bit | W = Writable bit |
| -n = Value at POR | '1' = Bit is set |
| | '0' = Bit is cleared |
| | x = Bit is unknown |
| | U = Unimplemented bit, read as '0' |

bit 15-9 **Unimplemented:** Read as '0'

bit 7-5 **IPL<2:0>:** CPU Interrupt Priority Level Status bits^(2,3)

- 111 = CPU interrupt priority level is 7 (15); user interrupts are disabled
- 110 = CPU interrupt priority level is 6 (14)
- 101 = CPU interrupt priority level is 5 (13)
- 100 = CPU interrupt priority level is 4 (12)
- 011 = CPU interrupt priority level is 3 (11)
- 010 = CPU interrupt priority level is 2 (10)
- 001 = CPU interrupt priority level is 1 (9)
- 000 = CPU interrupt priority level is 0 (8)

- Note 1:** See Register 3-1 for the description of the remaining bits (bit 8, 4, 3, 2, 1 and 0) that are not dedicated to interrupt control functions.
- 2:** The IPL bits are concatenated with the IPL3 (CORCON<3>) bit to form the CPU interrupt priority level. The value in parentheses indicates the interrupt priority level if IPL3 = 1.
- 3:** The IPL Status bits are read-only when NSTDIS (INTCON1<15>) = 1.

PIC24FJ256DA210 FAMILY

[查询PIC24FJ256DA106供应商](#)

REGISTER 7-2: CORCON: CPU CONTROL REGISTER

| | | | | | | | |
|--------|-----|-----|-----|-----|-----|-------|-----|
| U-0 | U-0 | U-0 | U-0 | U-0 | U-0 | U-0 | U-0 |
| — | — | — | — | — | — | — | — |
| bit 15 | | | | | | bit 8 | |

| | | | | | | | |
|-------|-----|-----|-----|---------------------|-----|-----|-----|
| U-0 | U-0 | U-0 | U-0 | R/C-0, HSC | r-1 | U-0 | U-0 |
| — | — | — | — | IPL3 ⁽¹⁾ | r | — | — |
| bit 7 | | | | bit 0 | | | |

| | | | |
|-------------------|------------------|------------------------------------|---------------------------------------|
| Legend: | r = Reserved bit | C = Clearable bit | HSC = Hardware Settable/Clearable bit |
| R = Readable bit | W = Writable bit | U = Unimplemented bit, read as '0' | |
| -n = Value at POR | '1' = Bit is set | '0' = Bit is cleared | x = Bit is unknown |

bit 15-4 **Unimplemented:** Read as '0'

bit 3 **IPL3:** CPU Interrupt Priority Level Status bit⁽¹⁾
 1 = CPU interrupt priority level is greater than 7
 0 = CPU interrupt priority level is 7 or less

bit 2 **Reserved:** Read as '1'

bit 1-0 **Unimplemented:** Read as '0'

Note 1: The IPL3 bit is concatenated with the IPL<2:0> bits (SR<7:5>) to form the CPU interrupt priority level; see Register 3-2 for bit description.

PIC24FJ256DA210 FAMILY

[查询PIC24FJ256DA106供应商](#)

REGISTER 7-3: INTCON1: INTERRUPT CONTROL REGISTER 1

| | | | | | | | |
|--------|-----|-----|-----|-----|-----|-----|-------|
| R/W-0 | U-0 | U-0 | U-0 | U-0 | U-0 | U-0 | U-0 |
| NSTDIS | — | — | — | — | — | — | — |
| bit 15 | | | | | | | bit 8 |

| | | | | | | | |
|-------|-----|-----|-----------|-----------|-----------|-----------|-------|
| U-0 | U-0 | U-0 | R/W-0, HS | R/W-0, HS | R/W-0, HS | R/W-0, HS | U-0 |
| — | — | — | MATHERR | ADDRERR | STKERR | OSCFAIL | — |
| bit 7 | | | | | | | bit 0 |

| | |
|------------------------------------|----------------------------|
| Legend: | HS = Hardware Settable bit |
| R = Readable bit | W = Writable bit |
| U = Unimplemented bit, read as '0' | |
| -n = Value at POR | '1' = Bit is set |
| | '0' = Bit is cleared |
| | x = Bit is unknown |

- bit 15 **NSTDIS:** Interrupt Nesting Disable bit
 1 = Interrupt nesting is disabled
 0 = Interrupt nesting is enabled
- bit 14-5 **Unimplemented:** Read as '0'
- bit 4 **MATHERR:** Arithmetic Error Trap Status bit
 1 = Overflow trap has occurred
 0 = Overflow trap has not occurred
- bit 3 **ADDRERR:** Address Error Trap Status bit
 1 = Address error trap has occurred
 0 = Address error trap has not occurred
- bit 2 **STKERR:** Stack Error Trap Status bit
 1 = Stack error trap has occurred
 0 = Stack error trap has not occurred
- bit 1 **OSCFAIL:** Oscillator Failure Trap Status bit
 1 = Oscillator failure trap has occurred
 0 = Oscillator failure trap has not occurred
- bit 0 **Unimplemented:** Read as '0'

PIC24FJ256DA210 FAMILY

[查询PIC24FJ256DA106供应商](#)

REGISTER 7-4: INTCON2: INTERRUPT CONTROL REGISTER 2

| | | | | | | | |
|--------|----------|-----|-----|-----|-----|-----|-------|
| R/W-0 | R-0, HSC | U-0 | U-0 | U-0 | U-0 | U-0 | U-0 |
| ALTIVT | DISI | — | — | — | — | — | — |
| bit 15 | | | | | | | bit 8 |

| | | | | | | | |
|-------|-----|-----|--------|--------|--------|--------|--------|
| U-0 | U-0 | U-0 | R/W-0 | R/W-0 | R/W-0 | R/W-0 | R/W-0 |
| — | — | — | INT4EP | INT3EP | INT2EP | INT1EP | INT0EP |
| bit 7 | | | | | | | bit 0 |

| | | | |
|-------------------|---------------------------------------|------------------------------------|--------------------|
| Legend: | HSC = Hardware Settable/Clearable bit | | |
| R = Readable bit | W = Writable bit | U = Unimplemented bit, read as '0' | |
| -n = Value at POR | '1' = Bit is set | '0' = Bit is cleared | x = Bit is unknown |

- bit 15 **ALTIVT:** Enable Alternate Interrupt Vector Table bit
 1 = Use Alternate Interrupt Vector Table
 0 = Use standard (default) vector table
- bit 14 **DISI:** DISI Instruction Status bit
 1 = DISI instruction is active
 0 = DISI instruction is not active
- bit 13-5 **Unimplemented:** Read as '0'
- bit 4 **INT4EP:** External Interrupt 4 Edge Detect Polarity Select bit
 1 = Interrupt on negative edge
 0 = Interrupt on positive edge
- bit 3 **INT3EP:** External Interrupt 3 Edge Detect Polarity Select bit
 1 = Interrupt on negative edge
 0 = Interrupt on positive edge
- bit 2 **INT2EP:** External Interrupt 2 Edge Detect Polarity Select bit
 1 = Interrupt on negative edge
 0 = Interrupt on positive edge
- bit 1 **INT1EP:** External Interrupt 1 Edge Detect Polarity Select bit
 1 = Interrupt on negative edge
 0 = Interrupt on positive edge
- bit 0 **INT0EP:** External Interrupt 0 Edge Detect Polarity Select bit
 1 = Interrupt on negative edge
 0 = Interrupt on positive edge

PIC24FJ256DA210 FAMILY

[查询PIC24FJ256DA106供应商](#)

REGISTER 7-5: IFS0: INTERRUPT FLAG STATUS REGISTER 0

| | | | | | | | |
|--------|-----|-----------|-----------|-----------|-----------|-----------|-----------|
| U-0 | U-0 | R/W-0, HS | R/W-0, HS | R/W-0, HS | R/W-0, HS | R/W-0, HS | R/W-0, HS |
| — | — | AD1IF | U1TXIF | U1RXIF | SPI1IF | SPF1IF | T3IF |
| bit 15 | | | | | | | bit 8 |

| | | | | | | | |
|-----------|-----------|-----------|-----|-----------|-----------|-----------|-----------|
| R/W-0, HS | R/W-0, HS | R/W-0, HS | U-0 | R/W-0, HS | R/W-0, HS | R/W-0, HS | R/W-0, HS |
| T2IF | OC2IF | IC2IF | — | T1IF | OC1IF | IC1IF | INT0IF |
| bit 7 | | | | | | | bit 0 |

| | |
|-------------------|------------------------------------|
| Legend: | HS = Hardware Settable bit |
| R = Readable bit | W = Writable bit |
| -n = Value at POR | '1' = Bit is set |
| | U = Unimplemented bit, read as '0' |
| | '0' = Bit is cleared |
| | x = Bit is unknown |

- bit 15-14 **Unimplemented:** Read as '0'
- bit 13 **AD1IF:** A/D Conversion Complete Interrupt Flag Status bit
 - 1 = Interrupt request has occurred
 - 0 = Interrupt request has not occurred
- bit 12 **U1TXIF:** UART1 Transmitter Interrupt Flag Status bit
 - 1 = Interrupt request has occurred
 - 0 = Interrupt request has not occurred
- bit 11 **U1RXIF:** UART1 Receiver Interrupt Flag Status bit
 - 1 = Interrupt request has occurred
 - 0 = Interrupt request has not occurred
- bit 10 **SPI1IF:** SPI1 Event Interrupt Flag Status bit
 - 1 = Interrupt request has occurred
 - 0 = Interrupt request has not occurred
- bit 9 **SPF1IF:** SPI1 Fault Interrupt Flag Status bit
 - 1 = Interrupt request has occurred
 - 0 = Interrupt request has not occurred
- bit 8 **T3IF:** Timer3 Interrupt Flag Status bit
 - 1 = Interrupt request has occurred
 - 0 = Interrupt request has not occurred
- bit 7 **T2IF:** Timer2 Interrupt Flag Status bit
 - 1 = Interrupt request has occurred
 - 0 = Interrupt request has not occurred
- bit 6 **OC2IF:** Output Compare Channel 2 Interrupt Flag Status bit
 - 1 = Interrupt request has occurred
 - 0 = Interrupt request has not occurred
- bit 5 **IC2IF:** Input Capture Channel 2 Interrupt Flag Status bit
 - 1 = Interrupt request has occurred
 - 0 = Interrupt request has not occurred
- bit 4 **Unimplemented:** Read as '0'
- bit 3 **T1IF:** Timer1 Interrupt Flag Status bit
 - 1 = Interrupt request has occurred
 - 0 = Interrupt request has not occurred
- bit 2 **OC1IF:** Output Compare Channel 1 Interrupt Flag Status bit
 - 1 = Interrupt request has occurred
 - 0 = Interrupt request has not occurred

PIC24FJ256DA210 FAMILY

[查询PIC24FJ256DA106供应商](#)

REGISTER 7-5: IFS0: INTERRUPT FLAG STATUS REGISTER 0 (CONTINUED)

- bit 1 **IC1IF:** Input Capture Channel 1 Interrupt Flag Status bit
 1 = Interrupt request has occurred
 0 = Interrupt request has not occurred
- bit 0 **INT0IF:** External Interrupt 0 Flag Status bit
 1 = Interrupt request has occurred
 0 = Interrupt request has not occurred

REGISTER 7-6: IFS1: INTERRUPT FLAG STATUS REGISTER 1

| | | | | | | | |
|-----------|-----------|-----------|-----------|-----------|-----------|-----------|-------|
| R/W-0, HS | R/W-0, HS | R/W-0, HS | R/W-0, HS | R/W-0, HS | R/W-0, HS | R/W-0, HS | U-0 |
| U2TXIF | U2RXIF | INT2IF | T5IF | T4IF | OC4IF | OC3IF | — |
| bit 15 | | | | | | | bit 8 |

| | | | | | | | |
|-----------|-----------|-----|-----------|-----------|-----------|-----------|-----------|
| R/W-0, HS | R/W-0, HS | U-0 | R/W-0, HS | R/W-0, HS | R/W-0, HS | R/W-0, HS | R/W-0, HS |
| IC8IF | IC7IF | — | INT1IF | CNIF | CMIF | MI2C1IF | SI2C1IF |
| bit 7 | | | | | | | bit 0 |

| | |
|-------------------|--|
| Legend: | HS = Hardware Settable bit |
| R = Readable bit | W = Writable bit U = Unimplemented bit, read as '0' |
| -n = Value at POR | '1' = Bit is set '0' = Bit is cleared x = Bit is unknown |

- bit 15 **U2TXIF:** UART2 Transmitter Interrupt Flag Status bit
 1 = Interrupt request has occurred
 0 = Interrupt request has not occurred
- bit 14 **U2RXIF:** UART2 Receiver Interrupt Flag Status bit
 1 = Interrupt request has occurred
 0 = Interrupt request has not occurred
- bit 13 **INT2IF:** External Interrupt 2 Flag Status bit
 1 = Interrupt request has occurred
 0 = Interrupt request has not occurred
- bit 12 **T5IF:** Timer5 Interrupt Flag Status bit
 1 = Interrupt request has occurred
 0 = Interrupt request has not occurred
- bit 11 **T4IF:** Timer4 Interrupt Flag Status bit
 1 = Interrupt request has occurred
 0 = Interrupt request has not occurred
- bit 10 **OC4IF:** Output Compare Channel 4 Interrupt Flag Status bit
 1 = Interrupt request has occurred
 0 = Interrupt request has not occurred
- bit 9 **OC3IF:** Output Compare Channel 3 Interrupt Flag Status bit
 1 = Interrupt request has occurred
 0 = Interrupt request has not occurred
- bit 8 **Unimplemented:** Read as '0'
- bit 7 **IC8IF:** Input Capture Channel 8 Interrupt Flag Status bit
 1 = Interrupt request has occurred
 0 = Interrupt request has not occurred
- bit 6 **IC7IF:** Input Capture Channel 7 Interrupt Flag Status bit
 1 = Interrupt request has occurred
 0 = Interrupt request has not occurred

PIC24FJ256DA210 FAMILY

[查询PIC24FJ256DA106供应商](#)

REGISTER 7-6: IFS1: INTERRUPT FLAG STATUS REGISTER 1 (CONTINUED)

- bit 5 **Unimplemented:** Read as '0'
- bit 4 **INT1IF:** External Interrupt 1 Flag Status bit
1 = Interrupt request has occurred
0 = Interrupt request has not occurred
- bit 3 **CNIF:** Input Change Notification Interrupt Flag Status bit
1 = Interrupt request has occurred
0 = Interrupt request has not occurred
- bit 2 **CMIF:** Comparator Interrupt Flag Status bit
1 = Interrupt request has occurred
0 = Interrupt request has not occurred
- bit 1 **M12C1IF:** Master I2C1 Event Interrupt Flag Status bit
1 = Interrupt request has occurred
0 = Interrupt request has not occurred
- bit 0 **S12C1IF:** Slave I2C1 Event Interrupt Flag Status bit
1 = Interrupt request has occurred
0 = Interrupt request has not occurred

REGISTER 7-7: IFS2: INTERRUPT FLAG STATUS REGISTER 2

| | | | | | | | |
|--------|-----|----------------------|-----------|-----------|-----------|-----------|-----------|
| U-0 | U-0 | R/W-0, HS | R/W-0, HS | R/W-0, HS | R/W-0, HS | R/W-0, HS | R/W-0, HS |
| — | — | PMPIF ⁽¹⁾ | OC8IF | OC7IF | OC6IF | OC5IF | IC6IF |
| bit 15 | | | | | | | bit 8 |

| | | | | | | | |
|-----------|-----------|-----------|-----|-----|-----|-----------|-----------|
| R/W-0, HS | R/W-0, HS | R/W-0, HS | U-0 | U-0 | U-0 | R/W-0, HS | R/W-0, HS |
| IC5IF | IC4IF | IC3IF | — | — | — | SPI2IF | SPF2IF |
| bit 7 | | | | | | | bit 0 |

| | |
|-------------------|--|
| Legend: | HS = Hardware Settable bit |
| R = Readable bit | W = Writable bit U = Unimplemented bit, read as '0' |
| -n = Value at POR | '1' = Bit is set '0' = Bit is cleared x = Bit is unknown |

- bit 15-14 **Unimplemented:** Read as '0'
- bit 13 **PMPIF:** Parallel Master Port Interrupt Flag Status bit⁽¹⁾
1 = Interrupt request has occurred
0 = Interrupt request has not occurred
- bit 12 **OC8IF:** Output Compare Channel 8 Interrupt Flag Status bit
1 = Interrupt request has occurred
0 = Interrupt request has not occurred
- bit 11 **OC7IF:** Output Compare Channel 7 Interrupt Flag Status bit
1 = Interrupt request has occurred
0 = Interrupt request has not occurred
- bit 10 **OC6IF:** Output Compare Channel 6 Interrupt Flag Status bit
1 = Interrupt request has occurred
0 = Interrupt request has not occurred
- bit 9 **OC5IF:** Output Compare Channel 5 Interrupt Flag Status bit
1 = Interrupt request has occurred
0 = Interrupt request has not occurred

Note 1: Not available in PIC24FJXXDAX06 devices.

PIC24FJ256DA210 FAMILY

[查询PIC24FJ256DA106供应商](#)

REGISTER 7-7: IFS2: INTERRUPT FLAG STATUS REGISTER 2 (CONTINUED)

- bit 8 **IC6IF:** Input Capture Channel 6 Interrupt Flag Status bit
1 = Interrupt request has occurred
0 = Interrupt request has not occurred
- bit 7 **IC5IF:** Input Capture Channel 5 Interrupt Flag Status bit
1 = Interrupt request has occurred
0 = Interrupt request has not occurred
- bit 6 **IC4IF:** Input Capture Channel 4 Interrupt Flag Status bit
1 = Interrupt request has occurred
0 = Interrupt request has not occurred
- bit 5 **IC3IF:** Input Capture Channel 3 Interrupt Flag Status bit
1 = Interrupt request has occurred
0 = Interrupt request has not occurred
- bit 4-2 **Unimplemented:** Read as '0'
- bit 1 **SPI2IF:** SPI2 Event Interrupt Flag Status bit
1 = Interrupt request has occurred
0 = Interrupt request has not occurred
- bit 0 **SPF2IF:** SPI2 Fault Interrupt Flag Status bit
1 = Interrupt request has occurred
0 = Interrupt request has not occurred

Note 1: Not available in PIC24FJXXDAX06 devices.

PIC24FJ256DA210 FAMILY

[查询PIC24FJ256DA106供应商](#)

REGISTER 7-8: IFS3: INTERRUPT FLAG STATUS REGISTER 3

| | | | | | | | |
|--------|-----------|-----|-----|-----|-----|-----|-------|
| U-0 | R/W-0, HS | U-0 | U-0 | U-0 | U-0 | U-0 | U-0 |
| — | RTCIF | — | — | — | — | — | — |
| bit 15 | | | | | | | bit 8 |

| | | | | | | | |
|-------|-----------|-----------|-----|-----|-----------|-----------|-------|
| U-0 | R/W-0, HS | R/W-0, HS | U-0 | U-0 | R/W-0, HS | R/W-0, HS | U-0 |
| — | INT4IF | INT3IF | — | — | MI2C2IF | SI2C2IF | — |
| bit 7 | | | | | | | bit 0 |

| | |
|-------------------|------------------------------------|
| Legend: | HS = Hardware Settable bit |
| R = Readable bit | W = Writable bit |
| -n = Value at POR | '1' = Bit is set |
| | U = Unimplemented bit, read as '0' |
| | '0' = Bit is cleared |
| | x = Bit is unknown |

- bit 15 **Unimplemented:** Read as '0'
- bit 14 **RTCIF:** Real-Time Clock/Calendar Interrupt Flag Status bit
 - 1 = Interrupt request has occurred
 - 0 = Interrupt request has not occurred
- bit 13-7 **Unimplemented:** Read as '0'
- bit 6 **INT4IF:** External Interrupt 4 Flag Status bit
 - 1 = Interrupt request has occurred
 - 0 = Interrupt request has not occurred
- bit 5 **INT3IF:** External Interrupt 3 Flag Status bit
 - 1 = Interrupt request has occurred
 - 0 = Interrupt request has not occurred
- bit 4-3 **Unimplemented:** Read as '0'
- bit 2 **MI2C2IF:** Master I2C2 Event Interrupt Flag Status bit
 - 1 = Interrupt request has occurred
 - 0 = Interrupt request has not occurred
- bit 1 **SI2C2IF:** Slave I2C2 Event Interrupt Flag Status bit
 - 1 = Interrupt request has occurred
 - 0 = Interrupt request has not occurred
- bit 0 **Unimplemented:** Read as '0'

PIC24FJ256DA210 FAMILY

[查询PIC24FJ256DA106供应商](#)

REGISTER 7-9: IFS4: INTERRUPT FLAG STATUS REGISTER 4

| | | | | | | | |
|--------|-----|-----------|-----|-----|-----|-----|-----------|
| U-0 | U-0 | R/W-0, HS | U-0 | U-0 | U-0 | U-0 | R/W-0, HS |
| — | — | CTMUIF | — | — | — | — | LVDIF |
| bit 15 | | | | | | | bit 8 |

| | | | | | | | |
|-------|-----|-----|-----|-----------|-----------|-----------|-------|
| U-0 | U-0 | U-0 | U-0 | R/W-0, HS | R/W-0, HS | R/W-0, HS | U-0 |
| — | — | — | — | CRCIF | U2ERIF | U1ERIF | — |
| bit 7 | | | | | | | bit 0 |

| | |
|-------------------|--|
| Legend: | HS = Hardware Settable bit |
| R = Readable bit | W = Writable bit U = Unimplemented bit, read as '0' |
| -n = Value at POR | '1' = Bit is set '0' = Bit is cleared x = Bit is unknown |

- bit 15-14 **Unimplemented:** Read as '0'
- bit 13 **CTMUIF:** CTMU Interrupt Flag Status bit
 - 1 = Interrupt request has occurred
 - 0 = Interrupt request has not occurred
- bit 12-9 **Unimplemented:** Read as '0'
- bit 8 **LVDIF:** Low-Voltage Detect Interrupt Flag Status bit
 - 1 = Interrupt request has occurred
 - 0 = Interrupt request has not occurred
- bit 7-4 **Unimplemented:** Read as '0'
- bit 3 **CRCIF:** CRC Generator Interrupt Flag Status bit
 - 1 = Interrupt request has occurred
 - 0 = Interrupt request has not occurred
- bit 2 **U2ERIF:** UART2 Error Interrupt Flag Status bit
 - 1 = Interrupt request has occurred
 - 0 = Interrupt request has not occurred
- bit 1 **U1ERIF:** UART1 Error Interrupt Flag Status bit
 - 1 = Interrupt request has occurred
 - 0 = Interrupt request has not occurred
- bit 0 **Unimplemented:** Read as '0'

PIC24FJ256DA210 FAMILY

[查询PIC24FJ256DA106供应商](#)

REGISTER 7-10: IFS5: INTERRUPT FLAG STATUS REGISTER 5

| | | | | | | | |
|--------|-----|-----------|-----------|-----------|-----------|-----------|-----------|
| U-0 | U-0 | R/W-0, HS | R/W-0, HS | R/W-0, HS | R/W-0, HS | R/W-0, HS | R/W-0, HS |
| — | — | IC9IF | OC9IF | SPI3IF | SPF3IF | U4TXIF | U4RXIF |
| bit 15 | | | | | | | bit 8 |

| | | | | | | | |
|-----------|-----------|-----------|-----------|-----------|-----------|-----------|-------|
| R/W-0, HS | R/W-0, HS | R/W-0, HS | R/W-0, HS | R/W-0, HS | R/W-0, HS | R/W-0, HS | U-0 |
| U4ERIF | USB1IF | MI2C3IF | SI2C3IF | U3TXIF | U3RXIF | U3ERIF | — |
| bit 7 | | | | | | | bit 0 |

| | | | |
|-------------------|----------------------------|------------------------------------|--------------------|
| Legend: | HS = Hardware Settable bit | | |
| R = Readable bit | W = Writable bit | U = Unimplemented bit, read as '0' | |
| -n = Value at POR | '1' = Bit is set | '0' = Bit is cleared | x = Bit is unknown |

- bit 15-14 **Unimplemented:** Read as '0'
- bit 13 **IC9IF:** Input Capture Channel 9 Interrupt Flag Status bit
1 = Interrupt request has occurred
0 = Interrupt request has not occurred
- bit 12 **OC9IF:** Output Compare Channel 9 Interrupt Flag Status bit
1 = Interrupt request has occurred
0 = Interrupt request has not occurred
- bit 11 **SPI3IF:** SPI3 Event Interrupt Flag Status bit
1 = Interrupt request has occurred
0 = Interrupt request has not occurred
- bit 10 **SPF3IF:** SPI3 Fault Interrupt Flag Status bit
1 = Interrupt request has occurred
0 = Interrupt request has not occurred
- bit 9 **U4TXIF:** UART4 Transmitter Interrupt Flag Status bit
1 = Interrupt request has occurred
0 = Interrupt request has not occurred
- bit 8 **U4RXIF:** UART4 Receiver Interrupt Flag Status bit
1 = Interrupt request has occurred
0 = Interrupt request has not occurred
- bit 7 **U4ERIF:** UART4 Error Interrupt Flag Status bit
1 = Interrupt request has occurred
0 = Interrupt request has not occurred
- bit 6 **USB1IF:** USB1 (USB OTG) Interrupt Flag Status bit
1 = Interrupt request has occurred
0 = Interrupt request has not occurred
- bit 5 **MI2C3IF:** Master I2C3 Event Interrupt Flag Status bit
1 = Interrupt request has occurred
0 = Interrupt request has not occurred
- bit 4 **SI2C3IF:** Slave I2C3 Event Interrupt Flag Status bit
1 = Interrupt request has occurred
0 = Interrupt request has not occurred
- bit 3 **U3TXIF:** UART3 Transmitter Interrupt Flag Status bit
1 = Interrupt request has occurred
0 = Interrupt request has not occurred
- bit 2 **U3RXIF:** UART3 Receiver Interrupt Flag Status bit
1 = Interrupt request has occurred
0 = Interrupt request has not occurred

PIC24FJ256DA210 FAMILY

[查询PIC24FJ256DA106供应商](#)

REGISTER 7-10: IFS5: INTERRUPT FLAG STATUS REGISTER 5 (CONTINUED)

- bit 1 **U3ERIF:** UART3 Error Interrupt Flag Status bit
 1 = Interrupt request has occurred
 0 = Interrupt request has not occurred
- bit 0 **Unimplemented:** Read as '0'

REGISTER 7-11: IFS6: INTERRUPT FLAG STATUS REGISTER 6

| | | | | | | | |
|--------|-----|-----|-----|-----|-----|-----|-------|
| U-0 | U-0 | U-0 | U-0 | U-0 | U-0 | U-0 | U-0 |
| — | — | — | — | — | — | — | — |
| bit 15 | | | | | | | bit 8 |

| | | | | | | | |
|-------|-----|-----|-----------|-----|-----|-----|-------|
| U-0 | U-0 | U-0 | R/W-0, HS | U-0 | U-0 | U-0 | U-0 |
| — | — | — | GFX1IF | — | — | — | — |
| bit 7 | | | | | | | bit 0 |

| | |
|-------------------|--|
| Legend: | HS = Hardware Settable bit |
| R = Readable bit | W = Writable bit U = Unimplemented bit, read as '0' |
| -n = Value at POR | '1' = Bit is set '0' = Bit is cleared x = Bit is unknown |

- bit 15-5 **Unimplemented:** Read as '0'
- bit 4 **GFX1IF:** Graphics 1 Interrupt Flag Status bit
 1 = Interrupt request has occurred
 0 = Interrupt request has not occurred
- bit 3-0 **Unimplemented:** Read as '0'

PIC24FJ256DA210 FAMILY

[查询PIC24FJ256DA106供应商](#)

REGISTER 7-12: IEC0: INTERRUPT ENABLE CONTROL REGISTER 0

| | | | | | | | |
|--------|-----|-------|--------|--------|--------|--------|-------|
| U-0 | U-0 | R/W-0 | R/W-0 | R/W-0 | R/W-0 | R/W-0 | R/W-0 |
| — | — | AD1IE | U1TXIE | U1RXIE | SPI1IE | SPF1IE | T3IE |
| bit 15 | | | | | | | bit 8 |

| | | | | | | | |
|-------|-------|-------|-----|-------|-------|-------|--------|
| R/W-0 | R/W-0 | R/W-0 | U-0 | R/W-0 | R/W-0 | R/W-0 | R/W-0 |
| T2IE | OC2IE | IC2IE | — | T1IE | OC1IE | IC1IE | INT0IE |
| bit 7 | | | | | | | bit 0 |

Legend:

R = Readable bit

W = Writable bit

U = Unimplemented bit, read as '0'

-n = Value at POR

'1' = Bit is set

'0' = Bit is cleared

x = Bit is unknown

- bit 15-14 **Unimplemented:** Read as '0'
- bit 13 **AD1IE:** A/D Conversion Complete Interrupt Enable bit
 1 = Interrupt request is enabled
 0 = Interrupt request is not enabled
- bit 12 **U1TXIE:** UART1 Transmitter Interrupt Enable bit
 1 = Interrupt request is enabled
 0 = Interrupt request is not enabled
- bit 11 **U1RXIE:** UART1 Receiver Interrupt Enable bit
 1 = Interrupt request is enabled
 0 = Interrupt request is not enabled
- bit 10 **SPI1IE:** SPI1 Transfer Complete Interrupt Enable bit
 1 = Interrupt request is enabled
 0 = Interrupt request is not enabled
- bit 9 **SPF1IE:** SPI1 Fault Interrupt Enable bit
 1 = Interrupt request is enabled
 0 = Interrupt request is not enabled
- bit 8 **T3IE:** Timer3 Interrupt Enable bit
 1 = Interrupt request is enabled
 0 = Interrupt request is not enabled
- bit 7 **T2IE:** Timer2 Interrupt Enable bit
 1 = Interrupt request is enabled
 0 = Interrupt request is not enabled
- bit 6 **OC2IE:** Output Compare Channel 2 Interrupt Enable bit
 1 = Interrupt request is enabled
 0 = Interrupt request is not enabled
- bit 5 **IC2IE:** Input Capture Channel 2 Interrupt Enable bit
 1 = Interrupt request is enabled
 0 = Interrupt request is not enabled
- bit 4 **Unimplemented:** Read as '0'
- bit 3 **T1IE:** Timer1 Interrupt Enable bit
 1 = Interrupt request is enabled
 0 = Interrupt request is not enabled
- bit 2 **OC1IE:** Output Compare Channel 1 Interrupt Enable bit
 1 = Interrupt request is enabled
 0 = Interrupt request is not enabled

PIC24FJ256DA210 FAMILY

查询PIC24FJ256DA106供应商

REGISTER 7-12: IEC0: INTERRUPT ENABLE CONTROL REGISTER 0 (CONTINUED)

- bit 1 **IC1IE:** Input Capture Channel 1 Interrupt Enable bit
 1 = Interrupt request is enabled
 0 = Interrupt request is not enabled
- bit 0 **INT0IE:** External Interrupt 0 Enable bit
 1 = Interrupt request is enabled
 0 = Interrupt request is not enabled

REGISTER 7-13: IEC1: INTERRUPT ENABLE CONTROL REGISTER 1

| | | | | | | | |
|--------|--------|-----------------------|-------|-------|-------|-------|-------|
| R/W-0 | R/W-0 | R/W-0 | R/W-0 | R/W-0 | R/W-0 | R/W-0 | U-0 |
| U2TXIE | U2RXIE | INT2IE ⁽¹⁾ | T5IE | T4IE | OC4IE | OC3IE | — |
| bit 15 | | | | | | | bit 8 |

| | | | | | | | |
|-------|-------|-----|-----------------------|-------|-------|---------|---------|
| R/W-0 | R/W-0 | U-0 | R/W-0 | R/W-0 | R/W-0 | R/W-0 | R/W-0 |
| IC8IE | IC7IE | — | INT1IE ⁽¹⁾ | CNIE | CMIE | MI2C1IE | SI2C1IE |
| bit 7 | | | | | | | bit 0 |

Legend:

R = Readable bit W = Writable bit U = Unimplemented bit, read as '0'
 -n = Value at POR '1' = Bit is set '0' = Bit is cleared x = Bit is unknown

- bit 15 **U2TXIE:** UART2 Transmitter Interrupt Enable bit
 1 = Interrupt request is enabled
 0 = Interrupt request is not enabled
- bit 14 **U2RXIE:** UART2 Receiver Interrupt Enable bit
 1 = Interrupt request is enabled
 0 = Interrupt request is not enabled
- bit 13 **INT2IE:** External Interrupt 2 Enable bit⁽¹⁾
 1 = Interrupt request is enabled
 0 = Interrupt request is not enabled
- bit 12 **T5IE:** Timer5 Interrupt Enable bit
 1 = Interrupt request is enabled
 0 = Interrupt request is not enabled
- bit 11 **T4IE:** Timer4 Interrupt Enable bit
 1 = Interrupt request is enabled
 0 = Interrupt request is not enabled
- bit 10 **OC4IE:** Output Compare Channel 4 Interrupt Enable bit
 1 = Interrupt request is enabled
 0 = Interrupt request is not enabled
- bit 9 **OC3IE:** Output Compare Channel 3 Interrupt Enable bit
 1 = Interrupt request is enabled
 0 = Interrupt request is not enabled
- bit 8 **Unimplemented:** Read as '0'
- bit 7 **IC8IE:** Input Capture Channel 8 Interrupt Enable bit
 1 = Interrupt request is enabled
 0 = Interrupt request is not enabled

Note 1: If an external interrupt is enabled, the interrupt input must also be configured to an available RPx or RPIx pin. See **Section 10.4 “Peripheral Pin Select (PPS)”** for more information.

PIC24FJ256DA210 FAMILY

[查询PIC24FJ256DA106供应商](#)

REGISTER 7-13: IEC1: INTERRUPT ENABLE CONTROL REGISTER 1 (CONTINUED)

| | |
|-------|---|
| bit 6 | IC7IE: Input Capture Channel 7 Interrupt Enable bit 1 = Interrupt request is enabled 0 = Interrupt request is not enabled |
| bit 5 | Unimplemented: Read as '0' |
| bit 4 | INT1IE: External Interrupt 1 Enable bit ⁽¹⁾ 1 = Interrupt request is enabled 0 = Interrupt request is not enabled |
| bit 3 | CNIE: Input Change Notification Interrupt Enable bit 1 = Interrupt request is enabled 0 = Interrupt request is not enabled |
| bit 2 | CMIE: Comparator Interrupt Enable bit 1 = Interrupt request is enabled 0 = Interrupt request is not enabled |
| bit 1 | MI2C1IE: Master I2C1 Event Interrupt Enable bit 1 = Interrupt request is enabled 0 = Interrupt request is not enabled |
| bit 0 | SI2C1IE: Slave I2C1 Event Interrupt Enable bit 1 = Interrupt request is enabled 0 = Interrupt request is not enabled |

Note 1: If an external interrupt is enabled, the interrupt input must also be configured to an available RPx or RPIx pin. See **Section 10.4 “Peripheral Pin Select (PPS)”** for more information.

PIC24FJ256DA210 FAMILY

[查询PIC24FJ256DA106供应商](#)

REGISTER 7-14: IEC2: INTERRUPT ENABLE CONTROL REGISTER 2

| | | | | | | | |
|--------|-----|----------------------|-------|-------|-------|-------|-------|
| U-0 | U-0 | R/W-0 | R/W-0 | R/W-0 | R/W-0 | R/W-0 | R/W-0 |
| — | — | PMPIE ⁽¹⁾ | OC8IE | OC7IE | OC6IE | OC5IE | IC6IE |
| bit 15 | | | | | | | bit 8 |

| | | | | | | | |
|-------|-------|-------|-----|-----|-----|--------|--------|
| R/W-0 | R/W-0 | R/W-0 | U-0 | U-0 | U-0 | R/W-0 | R/W-0 |
| IC5IE | IC4IE | IC3IE | — | — | — | SPI2IE | SPF2IE |
| bit 7 | | | | | | | bit 0 |

Legend:

R = Readable bit

W = Writable bit

U = Unimplemented bit, read as '0'

-n = Value at POR

'1' = Bit is set

'0' = Bit is cleared

x = Bit is unknown

- bit 15-14 **Unimplemented:** Read as '0'
- bit 13 **PMPIE:** Parallel Master Port Interrupt Enable bit⁽¹⁾
 1 = Interrupt request is enabled
 0 = Interrupt request is not enabled
- bit 12 **OC8IE:** Output Compare Channel 8 Interrupt Enable bit
 1 = Interrupt request is enabled
 0 = Interrupt request is not enabled
- bit 11 **OC7IE:** Output Compare Channel 7 Interrupt Enable bit
 1 = Interrupt request is enabled
 0 = Interrupt request is not enabled
- bit 10 **OC6IE:** Output Compare Channel 6 Interrupt Enable bit
 1 = Interrupt request is enabled
 0 = Interrupt request is not enabled
- bit 9 **OC5IE:** Output Compare Channel 5 Interrupt Enable bit
 1 = Interrupt request is enabled
 0 = Interrupt request is not enabled
- bit 8 **IC6IE:** Input Capture Channel 6 Interrupt Enable bit
 1 = Interrupt request is enabled
 0 = Interrupt request is not enabled
- bit 7 **IC5IE:** Input Capture Channel 5 Interrupt Enable bit
 1 = Interrupt request is enabled
 0 = Interrupt request is not enabled
- bit 6 **IC4IE:** Input Capture Channel 4 Interrupt Enable bit
 1 = Interrupt request is enabled
 0 = Interrupt request is not enabled
- bit 5 **IC3IE:** Input Capture Channel 3 Interrupt Enable bit
 1 = Interrupt request is enabled
 0 = Interrupt request is not enabled
- bit 4-2 **Unimplemented:** Read as '0'
- bit 1 **SPI2IE:** SPI2 Event Interrupt Enable bit
 1 = Interrupt request is enabled
 0 = Interrupt request is not enabled
- bit 0 **SPF2IE:** SPI2 Fault Interrupt Enable bit
 1 = Interrupt request is enabled
 0 = Interrupt request is not enabled

Note 1: Not available in 64-pin devices (PIC24FJXXXDAX06).

PIC24FJ256DA210 FAMILY

[查询PIC24FJ256DA106供应商](#)

REGISTER 7-15: IEC3: INTERRUPT ENABLE CONTROL REGISTER 3

| | | | | | | | |
|--------|-------|-----|-----|-----|-----|-----|-------|
| U-0 | R/W-0 | U-0 | U-0 | U-0 | U-0 | U-0 | U-0 |
| — | RTCIE | — | — | — | — | — | — |
| bit 15 | | | | | | | bit 8 |

| | | | | | | | |
|-------|-----------------------|-----------------------|-----|-----|---------|---------|-------|
| U-0 | R/W-0 | R/W-0 | U-0 | U-0 | R/W-0 | R/W-0 | U-0 |
| — | INT4IE ⁽¹⁾ | INT3IE ⁽¹⁾ | — | — | MI2C2IE | SI2C2IE | — |
| bit 7 | | | | | | | bit 0 |

Legend:

R = Readable bit

W = Writable bit

U = Unimplemented bit, read as '0'

-n = Value at POR

'1' = Bit is set

'0' = Bit is cleared

x = Bit is unknown

- bit 15 **Unimplemented:** Read as '0'
- bit 14 **RTCIE:** Real-Time Clock/Calendar Interrupt Enable bit
 1 = Interrupt request is enabled
 0 = Interrupt request is not enabled
- bit 13-7 **Unimplemented:** Read as '0'
- bit 6 **INT4IE:** External Interrupt 4 Enable bit⁽¹⁾
 1 = Interrupt request is enabled
 0 = Interrupt request is not enabled
- bit 5 **INT3IE:** External Interrupt 3 Enable bit⁽¹⁾
 1 = Interrupt request is enabled
 0 = Interrupt request is not enabled
- bit 4-3 **Unimplemented:** Read as '0'
- bit 2 **MI2C2IE:** Master I2C2 Event Interrupt Enable bit
 1 = Interrupt request is enabled
 0 = Interrupt request is not enabled
- bit 1 **SI2C2IE:** Slave I2C2 Event Interrupt Enable bit
 1 = Interrupt request is enabled
 0 = Interrupt request is not enabled
- bit 0 **Unimplemented:** Read as '0'

Note 1: If an external interrupt is enabled, the interrupt input must also be configured to an available RPx or RPIx pin. See **Section 10.4 “Peripheral Pin Select (PPS)”** for more information.

PIC24FJ256DA210 FAMILY

[查询PIC24FJ256DA106供应商](#)

REGISTER 7-16: IEC4: INTERRUPT ENABLE CONTROL REGISTER 4

| | | | | | | | |
|--------|-----|--------|-----|-----|-----|-----|-------|
| U-0 | U-0 | R/W-0 | U-0 | U-0 | U-0 | U-0 | R/W-0 |
| — | — | CTMUIE | — | — | — | — | LVDIE |
| bit 15 | | | | | | | bit 8 |

| | | | | | | | |
|-------|-----|-----|-----|-------|--------|--------|-------|
| U-0 | U-0 | U-0 | U-0 | R/W-0 | R/W-0 | R/W-0 | U-0 |
| — | — | — | — | CRCIE | U2ERIE | U1ERIE | — |
| bit 7 | | | | | | | bit 0 |

Legend:

R = Readable bit

W = Writable bit

U = Unimplemented bit, read as '0'

-n = Value at POR

'1' = Bit is set

'0' = Bit is cleared

x = Bit is unknown

- bit 15-14 **Unimplemented:** Read as '0'
- bit 13 **CTMUIE:** CTMU Interrupt Enable bit
1 = Interrupt request is enabled
0 = Interrupt request is not enabled
- bit 12-9 **Unimplemented:** Read as '0'
- bit 8 **LVDIE:** Low-Voltage Detect Interrupt Enable bit
1 = Interrupt request is enabled
0 = Interrupt request is not enabled
- bit 7-4 **Unimplemented:** Read as '0'
- bit 3 **CRCIE:** CRC Generator Interrupt Enable bit
1 = Interrupt request is enabled
0 = Interrupt request is not enabled
- bit 2 **U2ERIE:** UART2 Error Interrupt Enable bit
1 = Interrupt request is enabled
0 = Interrupt request is not enabled
- bit 1 **U1ERIE:** UART1 Error Interrupt Enable bit
1 = Interrupt request is enabled
0 = Interrupt request is not enabled
- bit 0 **Unimplemented:** Read as '0'

PIC24FJ256DA210 FAMILY

[查询PIC24FJ256DA106供应商](#)

REGISTER 7-17: IEC5: INTERRUPT ENABLE CONTROL REGISTER 5

| | | | | | | | |
|--------|-----|-------|-------|--------|--------|--------|--------|
| U-0 | U-0 | R/W-0 | R/W-0 | R/W-0 | R/W-0 | R/W-0 | R/W-0 |
| — | — | IC9IE | OC9IE | SPI3IE | SPF3IE | U4TXIE | U4RXIE |
| bit 15 | | | | | | | bit 8 |

| | | | | | | | |
|--------|--------|---------|---------|--------|--------|--------|-------|
| R/W-0 | R/W-0 | R/W-0 | R/W-0 | R/W-0 | R/W-0 | R/W-0 | U-0 |
| U4ERIE | USB1IE | MI2C3IE | SI2C3IE | U3TXIE | U3RXIE | U3ERIE | — |
| bit 7 | | | | | | | bit 0 |

Legend:

| | | |
|-------------------|------------------|------------------------------------|
| R = Readable bit | W = Writable bit | U = Unimplemented bit, read as '0' |
| -n = Value at POR | '1' = Bit is set | '0' = Bit is cleared |
| | | x = Bit is unknown |

- bit 15-14 **Unimplemented:** Read as '0'
- bit 13 **IC9IE:** Input Capture Channel 9 Interrupt Enable bit
 - 1 = Interrupt request enabled
 - 0 = Interrupt request not enabled
- bit 12 **OC9IE:** Output Compare Channel 9 Interrupt Enable bit
 - 1 = Interrupt request enabled
 - 0 = Interrupt request not enabled
- bit 11 **SPI3IE:** SPI3 Event Interrupt Enable bit
 - 1 = Interrupt request enabled
 - 0 = Interrupt request not enabled
- bit 10 **SPF3IE:** SPI3 Fault Interrupt Enable bit
 - 1 = Interrupt request enabled
 - 0 = Interrupt request not enabled
- bit 9 **U4TXIE:** UART4 Transmitter Interrupt Enable bit
 - 1 = Interrupt request enabled
 - 0 = Interrupt request not enabled
- bit 8 **U4RXIE:** UART4 Receiver Interrupt Enable bit
 - 1 = Interrupt request enabled
 - 0 = Interrupt request not enabled
- bit 7 **U4ERIE:** UART4 Error Interrupt Enable bit
 - 1 = Interrupt request enabled
 - 0 = Interrupt request not enabled
- bit 6 **USB1IE:** USB1 (USB OTG) Interrupt Enable bit
 - 1 = Interrupt request enabled
 - 0 = Interrupt request not enabled
- bit 5 **MI2C3IE:** Master I2C3 Event Interrupt Enable bit
 - 1 = Interrupt request enabled
 - 0 = Interrupt request not enabled
- bit 4 **SI2C3IE:** Slave I2C3 Event Interrupt Enable bit
 - 1 = Interrupt request enabled
 - 0 = Interrupt request not enabled
- bit 3 **U3TXIE:** UART3 Transmitter Interrupt Enable bit
 - 1 = Interrupt request enabled
 - 0 = Interrupt request not enabled
- bit 2 **U3RXIE:** UART3 Receiver Interrupt Enable bit
 - 1 = Interrupt request enabled
 - 0 = Interrupt request not enabled

PIC24FJ256DA210 FAMILY

[查询PIC24FJ256DA106供应商](#)

REGISTER 7-17: IEC5: INTERRUPT ENABLE CONTROL REGISTER 5 (CONTINUED)

- bit 1 **U3ERIE:** UART3 Error Interrupt Enable bit
 1 = Interrupt request is enabled
 0 = Interrupt request is not enabled
- bit 0 **Unimplemented:** Read as '0'

REGISTER 7-18: IEC6: INTERRUPT ENABLE CONTROL REGISTER 6

| | | | | | | | |
|--------|-----|-----|-----|-----|-----|-----|-------|
| U-0 | U-0 | U-0 | U-0 | U-0 | U-0 | U-0 | U-0 |
| — | — | — | — | — | — | — | — |
| bit 15 | | | | | | | bit 8 |

| | | | | | | | |
|-------|-----|-----|--------|-----|-----|-----|-------|
| U-0 | U-0 | U-0 | R/W-0 | U-0 | U-0 | U-0 | U-0 |
| — | — | — | GFX1IE | — | — | — | — |
| bit 7 | | | | | | | bit 0 |

Legend:

R = Readable bit

W = Writable bit

U = Unimplemented bit, read as '0'

-n = Value at POR

'1' = Bit is set

'0' = Bit is cleared

x = Bit is unknown

- bit 15-5 **Unimplemented:** Read as '0'
- bit 4 **GFX1IE:** Graphics 1 Interrupt Enable bit
 1 = Interrupt request is enabled
 0 = Interrupt request is not enabled
- bit 3-0 **Unimplemented:** Read as '0'

PIC24FJ256DA210 FAMILY

[查询PIC24FJ256DA106供应商](#)

REGISTER 7-19: IPC0: INTERRUPT PRIORITY CONTROL REGISTER 0

| | | | | | | | |
|--------|-------|-------|-------|-----|--------|--------|--------|
| U-0 | R/W-1 | R/W-0 | R/W-0 | U-0 | R/W-1 | R/W-0 | R/W-0 |
| — | T1IP2 | T1IP1 | T1IP0 | — | OC1IP2 | OC1IP1 | OC1IP0 |
| bit 15 | | | | | | bit 8 | |

| | | | | | | | |
|-------|--------|--------|--------|-----|---------|---------|---------|
| U-0 | R/W-1 | R/W-0 | R/W-0 | U-0 | R/W-1 | R/W-0 | R/W-0 |
| — | IC1IP2 | IC1IP1 | IC1IP0 | — | INT0IP2 | INT0IP1 | INT0IP0 |
| bit 7 | | | | | | bit 0 | |

Legend:

R = Readable bit

W = Writable bit

U = Unimplemented bit, read as '0'

-n = Value at POR

'1' = Bit is set

'0' = Bit is cleared

x = Bit is unknown

bit 15 **Unimplemented:** Read as '0'

bit 14-12 **T1IP<2:0>:** Timer1 Interrupt Priority bits

111 = Interrupt is priority 7 (highest priority interrupt)

.

.

001 = Interrupt is priority 1

000 = Interrupt source is disabled

bit 11 **Unimplemented:** Read as '0'

bit 10-8 **OC1IP<2:0>:** Output Compare Channel 1 Interrupt Priority bits

111 = Interrupt is priority 7 (highest priority interrupt)

.

.

.

001 = Interrupt is priority 1

000 = Interrupt source is disabled

bit 7 **Unimplemented:** Read as '0'

bit 6-4 **IC1IP<2:0>:** Input Capture Channel 1 Interrupt Priority bits

111 = Interrupt is priority 7 (highest priority interrupt)

.

.

.

001 = Interrupt is priority 1

000 = Interrupt source is disabled

bit 3 **Unimplemented:** Read as '0'

bit 2-0 **INT0IP<2:0>:** External Interrupt 0 Priority bits

111 = Interrupt is priority 7 (highest priority interrupt)

.

.

.

001 = Interrupt is priority 1

000 = Interrupt source is disabled

PIC24FJ256DA210 FAMILY

[查询PIC24FJ256DA106供应商](#)

REGISTER 7-20: IPC1: INTERRUPT PRIORITY CONTROL REGISTER 1

| | | | | | | | |
|--------|-------|-------|-------|-----|--------|--------|--------|
| U-0 | R/W-1 | R/W-0 | R/W-0 | U-0 | R/W-1 | R/W-0 | R/W-0 |
| — | T2IP2 | T2IP1 | T2IP0 | — | OC2IP2 | OC2IP1 | OC2IP0 |
| bit 15 | | | | | | | bit 8 |

| | | | | | | | |
|-------|--------|--------|--------|-----|-----|-----|-------|
| U-0 | R/W-1 | R/W-0 | R/W-0 | U-0 | U-0 | U-0 | U-0 |
| — | IC2IP2 | IC2IP1 | IC2IP0 | — | — | — | — |
| bit 7 | | | | | | | bit 0 |

Legend:

R = Readable bit

W = Writable bit

U = Unimplemented bit, read as '0'

-n = Value at POR

'1' = Bit is set

'0' = Bit is cleared

x = Bit is unknown

bit 15 **Unimplemented:** Read as '0'

bit 14-12 **T2IP<2:0>:** Timer2 Interrupt Priority bits

111 = Interrupt is priority 7 (highest priority interrupt)

•
•
•

001 = Interrupt is priority 1

000 = Interrupt source is disabled

bit 11 **Unimplemented:** Read as '0'

bit 10-8 **OC2IP<2:0>:** Output Compare Channel 2 Interrupt Priority bits

111 = Interrupt is priority 7 (highest priority interrupt)

•
•
•

001 = Interrupt is priority 1

000 = Interrupt source is disabled

bit 7 **Unimplemented:** Read as '0'

bit 6-4 **IC2IP<2:0>:** Input Capture Channel 2 Interrupt Priority bits

111 = Interrupt is priority 7 (highest priority interrupt)

•
•
•

001 = Interrupt is priority 1

000 = Interrupt source is disabled

bit 3-0 **Unimplemented:** Read as '0'

PIC24FJ256DA210 FAMILY

[查询PIC24FJ256DA106供应商](#)

REGISTER 7-21: IPC2: INTERRUPT PRIORITY CONTROL REGISTER 2

| | | | | | | | |
|--------|---------|---------|---------|-----|---------|---------|---------|
| U-0 | R/W-1 | R/W-0 | R/W-0 | U-0 | R/W-1 | R/W-0 | R/W-0 |
| — | U1RXIP2 | U1RXIP1 | U1RXIP0 | — | SPI1IP2 | SPI1IP1 | SPI1IP0 |
| bit 15 | | | | | | | bit 8 |

| | | | | | | | |
|-------|---------|---------|---------|-----|-------|-------|-------|
| U-0 | R/W-1 | R/W-0 | R/W-0 | U-0 | R/W-1 | R/W-0 | R/W-0 |
| — | SPF1IP2 | SPF1IP1 | SPF1IP0 | — | T3IP2 | T3IP1 | T3IP0 |
| bit 7 | | | | | | | bit 0 |

Legend:

R = Readable bit

W = Writable bit

U = Unimplemented bit, read as '0'

-n = Value at POR

'1' = Bit is set

'0' = Bit is cleared

x = Bit is unknown

- bit 15 **Unimplemented:** Read as '0'
- bit 14-12 **U1RXIP<2:0>:** UART1 Receiver Interrupt Priority bits
 111 = Interrupt is priority 7 (highest priority interrupt)
 .
 .
 .
 001 = Interrupt is priority 1
 000 = Interrupt source is disabled
- bit 11 **Unimplemented:** Read as '0'
- bit 10-8 **SPI1IP<2:0>:** SPI1 Event Interrupt Priority bits
 111 = Interrupt is priority 7 (highest priority interrupt)
 .
 .
 .
 001 = Interrupt is priority 1
 000 = Interrupt source is disabled
- bit 7 **Unimplemented:** Read as '0'
- bit 6-4 **SPF1IP<2:0>:** SPI1 Fault Interrupt Priority bits
 111 = Interrupt is priority 7 (highest priority interrupt)
 .
 .
 .
 001 = Interrupt is priority 1
 000 = Interrupt source is disabled
- bit 3 **Unimplemented:** Read as '0'
- bit 2-0 **T3IP<2:0>:** Timer3 Interrupt Priority bits
 111 = Interrupt is priority 7 (highest priority interrupt)
 .
 .
 .
 001 = Interrupt is priority 1
 000 = Interrupt source is disabled

PIC24FJ256DA210 FAMILY

[查询PIC24FJ256DA106供应商](#)

REGISTER 7-22: IPC3: INTERRUPT PRIORITY CONTROL REGISTER 3

| | | | | | | | |
|--------|-----|-----|-----|-----|-----|-----|-------|
| U-0 | U-0 | U-0 | U-0 | U-0 | U-0 | U-0 | U-0 |
| — | — | — | — | — | — | — | — |
| bit 15 | | | | | | | bit 8 |

| | | | | | | | |
|-------|--------|--------|--------|-----|---------|---------|---------|
| U-0 | R/W-1 | R/W-0 | R/W-0 | U-0 | R/W-1 | R/W-0 | R/W-0 |
| — | AD1IP2 | AD1IP1 | AD1IP0 | — | U1TXIP2 | U1TXIP1 | U1TXIP0 |
| bit 7 | | | | | | | bit 0 |

Legend:

R = Readable bit

W = Writable bit

U = Unimplemented bit, read as '0'

-n = Value at POR

'1' = Bit is set

'0' = Bit is cleared

x = Bit is unknown

bit 15-7 **Unimplemented:** Read as '0'

bit 6-4 **AD1IP<2:0>:** A/D Conversion Complete Interrupt Priority bits

111 = Interrupt is priority 7 (highest priority interrupt)

•

•

001 = Interrupt is priority 1

000 = Interrupt source is disabled

bit 3 **Unimplemented:** Read as '0'

bit 2-0 **U1TXIP<2:0>:** UART1 Transmitter Interrupt Priority bits

111 = Interrupt is priority 7 (highest priority interrupt)

•

•

001 = Interrupt is priority 1

000 = Interrupt source is disabled

PIC24FJ256DA210 FAMILY

[查询PIC24FJ256DA106供应商](#)

REGISTER 7-23: IPC4: INTERRUPT PRIORITY CONTROL REGISTER 4

| | | | | | | | |
|--------|-------|-------|-------|-----|-------|-------|-------|
| U-0 | R/W-1 | R/W-0 | R/W-0 | U-0 | R/W-1 | R/W-0 | R/W-0 |
| — | CNIP2 | CNIP1 | CNIP0 | — | CMIP2 | CMIP1 | CMIP0 |
| bit 15 | | | | | | | bit 8 |

| | | | | | | | |
|-------|----------|----------|----------|-----|----------|----------|----------|
| U-0 | R/W-1 | R/W-0 | R/W-0 | U-0 | R/W-1 | R/W-0 | R/W-0 |
| — | MI2C1IP2 | MI2C1IP1 | MI2C1IP0 | — | SI2C1IP2 | SI2C1IP1 | SI2C1IP0 |
| bit 7 | | | | | | | bit 0 |

Legend:

R = Readable bit W = Writable bit U = Unimplemented bit, read as '0'
 -n = Value at POR '1' = Bit is set '0' = Bit is cleared x = Bit is unknown

- bit 15 **Unimplemented:** Read as '0'
- bit 14-12 **CNIP<2:0>:** Input Change Notification Interrupt Priority bits
 - 111 = Interrupt is priority 7 (highest priority interrupt)
 -
 -
 - 001 = Interrupt is priority 1
 - 000 = Interrupt source is disabled
- bit 11 **Unimplemented:** Read as '0'
- bit 10-8 **CMIP<2:0>:** Comparator Interrupt Priority bits
 - 111 = Interrupt is priority 7 (highest priority interrupt)
 -
 -
 - 001 = Interrupt is priority 1
 - 000 = Interrupt source is disabled
- bit 7 **Unimplemented:** Read as '0'
- bit 6-4 **MI2C1IP<2:0>:** Master I2C1 Event Interrupt Priority bits
 - 111 = Interrupt is priority 7 (highest priority interrupt)
 -
 -
 - 001 = Interrupt is priority 1
 - 000 = Interrupt source is disabled
- bit 3 **Unimplemented:** Read as '0'
- bit 2-0 **SI2C1IP<2:0>:** Slave I2C1 Event Interrupt Priority bits
 - 111 = Interrupt is priority 7 (highest priority interrupt)
 -
 -
 - 001 = Interrupt is priority 1
 - 000 = Interrupt source is disabled

PIC24FJ256DA210 FAMILY

[查询PIC24FJ256DA106供应商](#)

REGISTER 7-24: IPC5: INTERRUPT PRIORITY CONTROL REGISTER 5

| | | | | | | | |
|--------|--------|--------|--------|-----|--------|--------|--------|
| U-0 | R/W-1 | R/W-0 | R/W-0 | U-0 | R/W-1 | R/W-0 | R/W-0 |
| — | IC8IP2 | IC8IP1 | IC8IP0 | — | IC7IP2 | IC7IP1 | IC7IP0 |
| bit 15 | | | | | | | bit 8 |

| | | | | | | | |
|-------|-----|-----|-----|-----|---------|---------|---------|
| U-0 | U-0 | U-0 | U-0 | U-0 | R/W-1 | R/W-0 | R/W-0 |
| — | — | — | — | — | INT1IP2 | INT1IP1 | INT1IP0 |
| bit 7 | | | | | | | bit 0 |

Legend:

R = Readable bit

W = Writable bit

U = Unimplemented bit, read as '0'

-n = Value at POR

'1' = Bit is set

'0' = Bit is cleared

x = Bit is unknown

bit 15 **Unimplemented:** Read as '0'

bit 14-12 **IC8IP<2:0>:** Input Capture Channel 8 Interrupt Priority bits

111 = Interrupt is priority 7 (highest priority interrupt)

.

.

001 = Interrupt is priority 1

000 = Interrupt source is disabled

bit 11 **Unimplemented:** Read as '0'

bit 10-8 **IC7IP<2:0>:** Input Capture Channel 7 Interrupt Priority bits

111 = Interrupt is priority 7 (highest priority interrupt)

.

.

001 = Interrupt is priority 1

000 = Interrupt source is disabled

bit 7-3 **Unimplemented:** Read as '0'

bit 2-0 **INT1IP<2:0>:** External Interrupt 1 Priority bits

111 = Interrupt is priority 7 (highest priority interrupt)

.

.

001 = Interrupt is priority 1

000 = Interrupt source is disabled

PIC24FJ256DA210 FAMILY

[查询PIC24FJ256DA106供应商](#)

REGISTER 7-25: IPC6: INTERRUPT PRIORITY CONTROL REGISTER 6

| | | | | | | | |
|--------|-------|-------|-------|-----|--------|--------|--------|
| U-0 | R/W-1 | R/W-0 | R/W-0 | U-0 | R/W-1 | R/W-0 | R/W-0 |
| — | T4IP2 | T4IP1 | T4IP0 | — | OC4IP2 | OC4IP1 | OC4IP0 |
| bit 15 | | | | | | bit 8 | |

| | | | | | | | |
|-------|--------|--------|--------|-----|-----|-------|-----|
| U-0 | R/W-1 | R/W-0 | R/W-0 | U-0 | U-0 | U-0 | U-0 |
| — | OC3IP2 | OC3IP1 | OC3IP0 | — | — | — | — |
| bit 7 | | | | | | bit 0 | |

Legend:

R = Readable bit W = Writable bit U = Unimplemented bit, read as '0'
 -n = Value at POR '1' = Bit is set '0' = Bit is cleared x = Bit is unknown

- bit 15 **Unimplemented:** Read as '0'
- bit 14-12 **T4IP<2:0>:** Timer4 Interrupt Priority bits
 - 111 = Interrupt is priority 7 (highest priority interrupt)
 -
 -
 -
 - 001 = Interrupt is priority 1
 - 000 = Interrupt source is disabled
- bit 11 **Unimplemented:** Read as '0'
- bit 10-8 **OC4IP<2:0>:** Output Compare Channel 4 Interrupt Priority bits
 - 111 = Interrupt is priority 7 (highest priority interrupt)
 -
 -
 -
 - 001 = Interrupt is priority 1
 - 000 = Interrupt source is disabled
- bit 7 **Unimplemented:** Read as '0'
- bit 6-4 **OC3IP<2:0>:** Output Compare Channel 3 Interrupt Priority bits
 - 111 = Interrupt is priority 7 (highest priority interrupt)
 -
 -
 -
 - 001 = Interrupt is priority 1
 - 000 = Interrupt source is disabled
- bit 3-0 **Unimplemented:** Read as '0'

PIC24FJ256DA210 FAMILY

[查询PIC24FJ256DA106供应商](#)

REGISTER 7-26: IPC7: INTERRUPT PRIORITY CONTROL REGISTER 7

| | | | | | | | |
|--------|---------|---------|---------|-----|---------|---------|---------|
| U-0 | R/W-1 | R/W-0 | R/W-0 | U-0 | R/W-1 | R/W-0 | R/W-0 |
| — | U2TXIP2 | U2TXIP1 | U2TXIP0 | — | U2RXIP2 | U2RXIP1 | U2RXIP0 |
| bit 15 | | | | | | | bit 8 |

| | | | | | | | |
|-------|---------|---------|---------|-----|-------|-------|-------|
| U-0 | R/W-1 | R/W-0 | R/W-0 | U-0 | R/W-1 | R/W-0 | R/W-0 |
| — | INT2IP2 | INT2IP1 | INT2IP0 | — | T5IP2 | T5IP1 | T5IP0 |
| bit 7 | | | | | | | bit 0 |

Legend:

R = Readable bit

W = Writable bit

U = Unimplemented bit, read as '0'

-n = Value at POR

'1' = Bit is set

'0' = Bit is cleared

x = Bit is unknown

- bit 15 **Unimplemented:** Read as '0'
- bit 14-12 **U2TXIP<2:0>:** UART2 Transmitter Interrupt Priority bits
 111 = Interrupt is priority 7 (highest priority interrupt)
 .
 .
 .
 001 = Interrupt is priority 1
 000 = Interrupt source is disabled
- bit 11 **Unimplemented:** Read as '0'
- bit 10-8 **U2RXIP<2:0>:** UART2 Receiver Interrupt Priority bits
 111 = Interrupt is priority 7 (highest priority interrupt)
 .
 .
 .
 001 = Interrupt is priority 1
 000 = Interrupt source is disabled
- bit 7 **Unimplemented:** Read as '0'
- bit 6-4 **INT2IP<2:0>:** External Interrupt 2 Priority bits
 111 = Interrupt is priority 7 (highest priority interrupt)
 .
 .
 .
 001 = Interrupt is priority 1
 000 = Interrupt source is disabled
- bit 3 **Unimplemented:** Read as '0'
- bit 2-0 **T5IP<2:0>:** Timer5 Interrupt Priority bits
 111 = Interrupt is priority 7 (highest priority interrupt)
 .
 .
 .
 001 = Interrupt is priority 1
 000 = Interrupt source is disabled

PIC24FJ256DA210 FAMILY

[查询PIC24FJ256DA106供应商](#)

REGISTER 7-27: IPC8: INTERRUPT PRIORITY CONTROL REGISTER 8

| | | | | | | | |
|--------|-----|-----|-----|-----|-----|-----|-------|
| U-0 | U-0 | U-0 | U-0 | U-0 | U-0 | U-0 | U-0 |
| — | — | — | — | — | — | — | — |
| bit 15 | | | | | | | bit 8 |

| | | | | | | | |
|-------|---------|---------|---------|-----|---------|---------|---------|
| U-0 | R/W-1 | R/W-0 | R/W-0 | U-0 | R/W-1 | R/W-0 | R/W-0 |
| — | SPI2IP2 | SPI2IP1 | SPI2IP0 | — | SPF2IP2 | SPF2IP1 | SPF2IP0 |
| bit 7 | | | | | | | bit 0 |

Legend:

R = Readable bit

W = Writable bit

U = Unimplemented bit, read as '0'

-n = Value at POR

'1' = Bit is set

'0' = Bit is cleared

x = Bit is unknown

bit 15-7 **Unimplemented:** Read as '0'

bit 6-4 **SPI2IP<2:0>:** SPI2 Event Interrupt Priority bits

111 = Interrupt is priority 7 (highest priority interrupt)

•

•

•

001 = Interrupt is priority 1

000 = Interrupt source is disabled

bit 3 **Unimplemented:** Read as '0'

bit 2-0 **SPF2IP<2:0>:** SPI2 Fault Interrupt Priority bits

111 = Interrupt is priority 7 (highest priority interrupt)

•

•

•

001 = Interrupt is priority 1

000 = Interrupt source is disabled

PIC24FJ256DA210 FAMILY

[查询PIC24FJ256DA106供应商](#)

REGISTER 7-28: IPC9: INTERRUPT PRIORITY CONTROL REGISTER 9

| | | | | | | | |
|--------|--------|--------|--------|-----|--------|--------|--------|
| U-0 | R/W-1 | R/W-0 | R/W-0 | U-0 | R/W-1 | R/W-0 | R/W-0 |
| — | IC5IP2 | IC5IP1 | IC5IP0 | — | IC4IP2 | IC4IP1 | IC4IP0 |
| bit 15 | | | | | | | bit 8 |

| | | | | | | | |
|-------|--------|--------|--------|-----|-----|-----|-------|
| U-0 | R/W-1 | R/W-0 | R/W-0 | U-0 | U-0 | U-0 | U-0 |
| — | IC3IP2 | IC3IP1 | IC3IP0 | — | — | — | — |
| bit 7 | | | | | | | bit 0 |

Legend:

R = Readable bit

W = Writable bit

U = Unimplemented bit, read as '0'

-n = Value at POR

'1' = Bit is set

'0' = Bit is cleared

x = Bit is unknown

- bit 15 **Unimplemented:** Read as '0'
- bit 14-12 **IC5IP<2:0>:** Input Capture Channel 5 Interrupt Priority bits
 111 = Interrupt is priority 7 (highest priority interrupt)
 .
 .
 .
 001 = Interrupt is priority 1
 000 = Interrupt source is disabled
- bit 11 **Unimplemented:** Read as '0'
- bit 10-8 **IC4IP<2:0>:** Input Capture Channel 4 Interrupt Priority bits
 111 = Interrupt is priority 7 (highest priority interrupt)
 .
 .
 .
 001 = Interrupt is priority 1
 000 = Interrupt source is disabled
- bit 7 **Unimplemented:** Read as '0'
- bit 6-4 **IC3IP<2:0>:** Input Capture Channel 3 Interrupt Priority bits
 111 = Interrupt is priority 7 (highest priority interrupt)
 .
 .
 .
 001 = Interrupt is priority 1
 000 = Interrupt source is disabled
- bit 3-0 **Unimplemented:** Read as '0'

PIC24FJ256DA210 FAMILY

[查询PIC24FJ256DA106供应商](#)

REGISTER 7-29: IPC10: INTERRUPT PRIORITY CONTROL REGISTER 10

| | | | | | | | |
|--------|--------|--------|--------|-----|--------|--------|--------|
| U-0 | R/W-1 | R/W-0 | R/W-0 | U-0 | R/W-1 | R/W-0 | R/W-0 |
| — | OC7IP2 | OC7IP1 | OC7IP0 | — | OC6IP2 | OC6IP1 | OC6IP0 |
| bit 15 | | | | | | | bit 8 |

| | | | | | | | |
|-------|--------|--------|--------|-----|--------|--------|--------|
| U-0 | R/W-1 | R/W-0 | R/W-0 | U-0 | R/W-1 | R/W-0 | R/W-0 |
| — | OC5IP2 | OC5IP1 | OC5IP0 | — | IC6IP2 | IC6IP1 | IC6IP0 |
| bit 7 | | | | | | | bit 0 |

Legend:

R = Readable bit

W = Writable bit

U = Unimplemented bit, read as '0'

-n = Value at POR

'1' = Bit is set

'0' = Bit is cleared

x = Bit is unknown

- bit 15 **Unimplemented:** Read as '0'
- bit 14-12 **OC7IP<2:0>:** Output Compare Channel 7 Interrupt Priority bits
 111 = Interrupt is priority 7 (highest priority interrupt)
 .
 .
 .
 001 = Interrupt is priority 1
 000 = Interrupt source is disabled
- bit 11 **Unimplemented:** Read as '0'
- bit 10-8 **OC6IP<2:0>:** Output Compare Channel 6 Interrupt Priority bits
 111 = Interrupt is priority 7 (highest priority interrupt)
 .
 .
 .
 001 = Interrupt is priority 1
 000 = Interrupt source is disabled
- bit 7 **Unimplemented:** Read as '0'
- bit 6-4 **OC5IP<2:0>:** Output Compare Channel 5 Interrupt Priority bits
 111 = Interrupt is priority 7 (highest priority interrupt)
 .
 .
 .
 001 = Interrupt is priority 1
 000 = Interrupt source is disabled
- bit 3 **Unimplemented:** Read as '0'
- bit 2-0 **IC6IP<2:0>:** Input Capture Channel 6 Interrupt Priority bits
 111 = Interrupt is priority 7 (highest priority interrupt)
 .
 .
 .
 001 = Interrupt is priority 1
 000 = Interrupt source is disabled

PIC24FJ256DA210 FAMILY

[查询PIC24FJ256DA106供应商](#)

REGISTER 7-30: IPC11: INTERRUPT PRIORITY CONTROL REGISTER 11

| | | | | | | | |
|--------|-----|-----|-----|-----|-----|-----|-------|
| U-0 | U-0 | U-0 | U-0 | U-0 | U-0 | U-0 | U-0 |
| — | — | — | — | — | — | — | — |
| bit 15 | | | | | | | bit 8 |

| | | | | | | | |
|-------|-----------------------|-----------------------|-----------------------|-----|--------|--------|--------|
| U-0 | R/W-1 | R/W-0 | R/W-0 | U-0 | R/W-1 | R/W-0 | R/W-0 |
| — | PMPIP2 ⁽¹⁾ | PMPIP1 ⁽¹⁾ | PMPIP0 ⁽¹⁾ | — | OC8IP2 | OC8IP1 | OC8IP0 |
| bit 7 | | | | | | | bit 0 |

Legend:

R = Readable bit W = Writable bit U = Unimplemented bit, read as '0'
 -n = Value at POR '1' = Bit is set '0' = Bit is cleared x = Bit is unknown

- bit 15-7 **Unimplemented:** Read as '0'
- bit 6-4 **PMPIP<2:0>:** Parallel Master Port Interrupt Priority bits⁽¹⁾
 - 111 = Interrupt is priority 7 (highest priority interrupt)
 -
 -
 - 001 = Interrupt is priority 1
 - 000 = Interrupt source is disabled
- bit 3 **Unimplemented:** Read as '0'
- bit 2-0 **OC8IP<2:0>:** Output Compare Channel 8 Interrupt Priority bits
 - 111 = Interrupt is priority 7 (highest priority interrupt)
 -
 -
 -
 - 001 = Interrupt is priority 1
 - 000 = Interrupt source is disabled

Note 1: Not available in 64-pin devices (PIC24FJXXXDAX06).

PIC24FJ256DA210 FAMILY

[查询PIC24FJ256DA106供应商](#)

REGISTER 7-31: IPC12: INTERRUPT PRIORITY CONTROL REGISTER 12

| | | | | | | | |
|--------|-----|-----|-----|-----|----------|----------|----------|
| U-0 | U-0 | U-0 | U-0 | U-0 | R/W-1 | R/W-0 | R/W-0 |
| — | — | — | — | — | MI2C2IP2 | MI2C2IP1 | MI2C2IP0 |
| bit 15 | | | | | | | bit 8 |

| | | | | | | | |
|-------|----------|----------|----------|-----|-----|-----|-------|
| U-0 | R/W-1 | R/W-0 | R/W-0 | U-0 | U-0 | U-0 | U-0 |
| — | SI2C2IP2 | SI2C2IP1 | SI2C2IP0 | — | — | — | — |
| bit 7 | | | | | | | bit 0 |

Legend:

R = Readable bit

W = Writable bit

U = Unimplemented bit, read as '0'

-n = Value at POR

'1' = Bit is set

'0' = Bit is cleared

x = Bit is unknown

bit 15-11 **Unimplemented:** Read as '0'

bit 10-8 **MI2C2IP<2:0>:** Master I2C2 Event Interrupt Priority bits

111 = Interrupt is priority 7 (highest priority interrupt)

•

•

•

001 = Interrupt is priority 1

000 = Interrupt source is disabled

bit 7 **Unimplemented:** Read as '0'

bit 6-4 **SI2C2IP<2:0>:** Slave I2C2 Event Interrupt Priority bits

111 = Interrupt is priority 7 (highest priority interrupt)

•

•

•

001 = Interrupt is priority 1

000 = Interrupt source is disabled

bit 3-0 **Unimplemented:** Read as '0'

PIC24FJ256DA210 FAMILY

[查询PIC24FJ256DA106供应商](#)

REGISTER 7-32: IPC13: INTERRUPT PRIORITY CONTROL REGISTER 13

| | | | | | | | |
|--------|-----|-----|-----|-----|---------|---------|---------|
| U-0 | U-0 | U-0 | U-0 | U-0 | R/W-1 | R/W-0 | R/W-0 |
| — | — | — | — | — | INT4IP2 | INT4IP1 | INT4IP0 |
| bit 15 | | | | | | | bit 8 |

| | | | | | | | |
|-------|---------|---------|---------|-----|-----|-----|-------|
| U-0 | R/W-1 | R/W-0 | R/W-0 | U-0 | U-0 | U-0 | U-0 |
| — | INT3IP2 | INT3IP1 | INT3IP0 | — | — | — | — |
| bit 7 | | | | | | | bit 0 |

Legend:

R = Readable bit

W = Writable bit

U = Unimplemented bit, read as '0'

-n = Value at POR

'1' = Bit is set

'0' = Bit is cleared

x = Bit is unknown

- bit 15-11 **Unimplemented:** Read as '0'
- bit 10-8 **INT4IP<2:0>:** External Interrupt 4 Priority bits
 111 = Interrupt is priority 7 (highest priority interrupt)
 .
 .
 .
 001 = Interrupt is priority 1
 000 = Interrupt source is disabled
- bit 7 **Unimplemented:** Read as '0'
- bit 6-4 **INT3IP<2:0>:** External Interrupt 3 Priority bits
 111 = Interrupt is priority 7 (highest priority interrupt)
 .
 .
 .
 001 = Interrupt is priority 1
 000 = Interrupt source is disabled
- bit 3-0 **Unimplemented:** Read as '0'

PIC24FJ256DA210 FAMILY

[查询PIC24FJ256DA106供应商](#)

REGISTER 7-33: IPC15: INTERRUPT PRIORITY CONTROL REGISTER 15

| | | | | | | | |
|--------|-----|-----|-----|-----|--------|--------|--------|
| U-0 | U-0 | U-0 | U-0 | U-0 | R/W-1 | R/W-0 | R/W-0 |
| — | — | — | — | — | RTCIP2 | RTCIP1 | RTCIP0 |
| bit 15 | | | | | | bit 8 | |

| | | | | | | | |
|-------|-----|-----|-----|-----|-----|-------|-----|
| U-0 | U-0 | U-0 | U-0 | U-0 | U-0 | U-0 | U-0 |
| — | — | — | — | — | — | — | — |
| bit 7 | | | | | | bit 0 | |

Legend:

R = Readable bit

W = Writable bit

U = Unimplemented bit, read as '0'

-n = Value at POR

'1' = Bit is set

'0' = Bit is cleared

x = Bit is unknown

bit 15-11 **Unimplemented:** Read as '0'

bit 10-8 **RTCIP<2:0>:** Real-Time Clock and Calendar Interrupt Priority bits

111 = Interrupt is priority 7 (highest priority interrupt)

.

.

.

001 = Interrupt is priority 1

000 = Interrupt source is disabled

bit 7-0 **Unimplemented:** Read as '0'

PIC24FJ256DA210 FAMILY

[查询PIC24FJ256DA106供应商](#)

REGISTER 7-34: IPC16: INTERRUPT PRIORITY CONTROL REGISTER 16

| | | | | | | | |
|--------|--------|--------|--------|-----|---------|---------|---------|
| U-0 | R/W-1 | R/W-0 | R/W-0 | U-0 | R/W-1 | R/W-0 | R/W-0 |
| — | CRCIP2 | CRCIP1 | CRCIP0 | — | U2ERIP2 | U2ERIP1 | U2ERIP0 |
| bit 15 | | | | | | | bit 8 |

| | | | | | | | |
|-------|---------|---------|---------|-----|-----|-----|-------|
| U-0 | R/W-1 | R/W-0 | R/W-0 | U-0 | U-0 | U-0 | U-0 |
| — | U1ERIP2 | U1ERIP1 | U1ERIP0 | — | — | — | — |
| bit 7 | | | | | | | bit 0 |

Legend:

R = Readable bit W = Writable bit U = Unimplemented bit, read as '0'
 -n = Value at POR '1' = Bit is set '0' = Bit is cleared x = Bit is unknown

- bit 15 **Unimplemented:** Read as '0'
- bit 14-12 **CRCIP<2:0>:** CRC Generator Error Interrupt Priority bits
 - 111 = Interrupt is priority 7 (highest priority interrupt)
 -
 -
 - 001 = Interrupt is priority 1
 - 000 = Interrupt source is disabled
- bit 11 **Unimplemented:** Read as '0'
- bit 10-8 **U2ERIP<2:0>:** UART2 Error Interrupt Priority bits
 - 111 = Interrupt is priority 7 (highest priority interrupt)
 -
 -
 -
 - 001 = Interrupt is priority 1
 - 000 = Interrupt source is disabled
- bit 7 **Unimplemented:** Read as '0'
- bit 6-4 **U1ERIP<2:0>:** UART1 Error Interrupt Priority bits
 - 111 = Interrupt is priority 7 (highest priority interrupt)
 -
 -
 -
 - 001 = Interrupt is priority 1
 - 000 = Interrupt source is disabled
- bit 3-0 **Unimplemented:** Read as '0'

PIC24FJ256DA210 FAMILY

[查询PIC24FJ256DA106供应商](#)

REGISTER 7-35: IPC18: INTERRUPT PRIORITY CONTROL REGISTER 18

| | | | | | | | |
|--------|-----|-----|-----|-----|-----|-----|-------|
| U-0 | U-0 | U-0 | U-0 | U-0 | U-0 | U-0 | U-0 |
| — | — | — | — | — | — | — | — |
| bit 15 | | | | | | | bit 8 |

| | | | | | | | |
|-------|-----|-----|-----|-----|--------|--------|--------|
| U-0 | U-0 | U-0 | U-0 | U-0 | R/W-1 | R/W-0 | R/W-0 |
| — | — | — | — | — | LVDIP2 | LVDIP1 | LVDIP0 |
| bit 7 | | | | | | | bit 0 |

Legend:

R = Readable bit W = Writable bit U = Unimplemented bit, read as '0'
 -n = Value at POR '1' = Bit is set '0' = Bit is cleared x = Bit is unknown

bit 15-3 **Unimplemented:** Read as '0'
 bit 2-0 **LVDIP<2:0>:** Low-Voltage Detect Interrupt Priority bits
 111 = Interrupt is priority 7 (highest priority interrupt)
 ·
 ·
 001 = Interrupt is priority 1
 000 = Interrupt source is disabled

REGISTER 7-36: IPC19: INTERRUPT PRIORITY CONTROL REGISTER 19

| | | | | | | | |
|--------|-----|-----|-----|-----|-----|-----|-------|
| U-0 | U-0 | U-0 | U-0 | U-0 | U-0 | U-0 | U-0 |
| — | — | — | — | — | — | — | — |
| bit 15 | | | | | | | bit 8 |

| | | | | | | | |
|-------|---------|---------|---------|-----|-----|-----|-------|
| U-0 | R/W-1 | R/W-0 | R/W-0 | U-0 | U-0 | U-0 | U-0 |
| — | CTMUIP2 | CTMUIP1 | CTMUIP0 | — | — | — | — |
| bit 7 | | | | | | | bit 0 |

Legend:

R = Readable bit W = Writable bit U = Unimplemented bit, read as '0'
 -n = Value at POR '1' = Bit is set '0' = Bit is cleared x = Bit is unknown

bit 15-7 **Unimplemented:** Read as '0'
 bit 6-4 **CTMUIP<2:0>:** CTMU Interrupt Priority bits
 111 = Interrupt is priority 7 (highest priority interrupt)
 ·
 ·
 001 = Interrupt is priority 1
 000 = Interrupt source is disabled
 bit 3-0 **Unimplemented:** Read as '0'

PIC24FJ256DA210 FAMILY

[查询PIC24FJ256DA106供应商](#)

REGISTER 7-37: IPC20: INTERRUPT PRIORITY CONTROL REGISTER 20

| | | | | | | | |
|--------|---------|---------|---------|-----|---------|---------|---------|
| U-0 | R/W-1 | R/W-0 | R/W-0 | U-0 | R/W-1 | R/W-0 | R/W-0 |
| — | U3TXIP2 | U3TXIP1 | U3TXIP0 | — | U3RXIP2 | U3RXIP1 | U3RXIP0 |
| bit 15 | | | | | | | bit 8 |

| | | | | | | | |
|-------|---------|---------|---------|-----|-----|-----|-------|
| U-0 | R/W-1 | R/W-0 | R/W-0 | U-0 | U-0 | U-0 | U-0 |
| — | U3ERIP2 | U3ERIP1 | U3ERIP0 | — | — | — | — |
| bit 7 | | | | | | | bit 0 |

Legend:

R = Readable bit

W = Writable bit

U = Unimplemented bit, read as '0'

-n = Value at POR

'1' = Bit is set

'0' = Bit is cleared

x = Bit is unknown

- bit 15 **Unimplemented:** Read as '0'
- bit 14-12 **U3TXIP<2:0>:** UART3 Transmitter Interrupt Priority bits
 111 = Interrupt is priority 7 (highest priority interrupt)
 .
 .
 001 = Interrupt is priority 1
 000 = Interrupt source is disabled
- bit 11 **Unimplemented:** Read as '0'
- bit 10-8 **U3RXIP<2:0>:** UART3 Receiver Interrupt Priority bits
 111 = Interrupt is priority 7 (highest priority interrupt)
 .
 .
 001 = Interrupt is priority 1
 000 = Interrupt source is disabled
- bit 7 **Unimplemented:** Read as '0'
- bit 6-4 **U3ERIP<2:0>:** UART3 Error Interrupt Priority bits
 111 = Interrupt is priority 7 (highest priority interrupt)
 .
 .
 001 = Interrupt is priority 1
 000 = Interrupt source is disabled
- bit 3-0 **Unimplemented:** Read as '0'

PIC24FJ256DA210 FAMILY

[查询PIC24FJ256DA106供应商](#)

REGISTER 7-38: IPC21: INTERRUPT PRIORITY CONTROL REGISTER 21

| | | | | | | | |
|--------|---------|---------|---------|-----|---------|---------|---------|
| U-0 | R/W-1 | R/W-0 | R/W-0 | U-0 | R/W-1 | R/W-0 | R/W-0 |
| — | U4ERIP2 | U4ERIP1 | U4ERIP0 | — | USB1IP2 | USB1IP1 | USB1IP0 |
| bit 15 | | | | | | | bit 8 |

| | | | | | | | |
|-------|----------|----------|----------|-----|----------|----------|----------|
| U-0 | R/W-1 | R/W-0 | R/W-0 | U-0 | R/W-1 | R/W-0 | R/W-0 |
| — | MI2C3IP2 | MI2C3IP1 | MI2C3IP0 | — | SI2C3IP2 | SI2C3IP1 | SI2C3IP0 |
| bit 7 | | | | | | | bit 0 |

Legend:

R = Readable bit

W = Writable bit

U = Unimplemented bit, read as '0'

-n = Value at POR

'1' = Bit is set

'0' = Bit is cleared

x = Bit is unknown

bit 15 **Unimplemented:** Read as '0'

bit 14-12 **U4ERIP<2:0>:** UART4 Error Interrupt Priority bits

111 = Interrupt is priority 7 (highest priority interrupt)

•

•

•

001 = Interrupt is priority 1

000 = Interrupt source is disabled

bit 11 **Unimplemented:** Read as '0'

bit 10-8 **USB1IP<2:0>:** USB1 (USB OTG) Interrupt Priority bits

111 = Interrupt is priority 7 (highest priority interrupt)

•

•

•

001 = Interrupt is priority 1

000 = Interrupt source is disabled

bit 7 **Unimplemented:** Read as '0'

bit 6-4 **MI2C3IP<2:0>:** Master I2C3 Event Interrupt Priority bits

111 = Interrupt is priority 7 (highest priority interrupt)

•

•

•

001 = Interrupt is priority 1

000 = Interrupt source is disabled

bit 3 **Unimplemented:** Read as '0'

bit 2-0 **SI2C3IP<2:0>:** Slave I2C3 Event Interrupt Priority bits

111 = Interrupt is priority 7 (highest priority interrupt)

•

•

•

001 = Interrupt is priority 1

000 = Interrupt source is disabled

PIC24FJ256DA210 FAMILY

[查询PIC24FJ256DA106供应商](#)

REGISTER 7-39: IPC22: INTERRUPT PRIORITY CONTROL REGISTER 22

| | | | | | | | |
|--------|---------|---------|---------|-----|---------|---------|---------|
| U-0 | R/W-1 | R/W-0 | R/W-0 | U-0 | R/W-1 | R/W-0 | R/W-0 |
| — | SPI3IP2 | SPI3IP1 | SPI3IP0 | — | SPF3IP2 | SPF3IP1 | SPF3IP0 |
| bit 15 | | | | | | | bit 8 |

| | | | | | | | |
|-------|---------|---------|---------|-----|---------|---------|---------|
| U-0 | R/W-1 | R/W-0 | R/W-0 | U-0 | R/W-1 | R/W-0 | R/W-0 |
| — | U4TXIP2 | U4TXIP1 | U4TXIP0 | — | U4RXIP2 | U4RXIP1 | U4RXIP0 |
| bit 7 | | | | | | | bit 0 |

Legend:

R = Readable bit

W = Writable bit

U = Unimplemented bit, read as '0'

-n = Value at POR

'1' = Bit is set

'0' = Bit is cleared

x = Bit is unknown

- bit 15 **Unimplemented:** Read as '0'
- bit 14-12 **SPI3IP<2:0>:** SPI3 Event Interrupt Priority bits
 111 = Interrupt is priority 7 (highest priority interrupt)
 .
 .
 001 = Interrupt is priority 1
 000 = Interrupt source is disabled
- bit 11 **Unimplemented:** Read as '0'
- bit 10-8 **SPF3IP<2:0>:** SPI3 Fault Interrupt Priority bits
 111 = Interrupt is priority 7 (highest priority interrupt)
 .
 .
 .
 001 = Interrupt is priority 1
 000 = Interrupt source is disabled
- bit 7 **Unimplemented:** Read as '0'
- bit 6-4 **U4TXIP<2:0>:** UART4 Transmitter Interrupt Priority bits
 111 = Interrupt is priority 7 (highest priority interrupt)
 .
 .
 .
 001 = Interrupt is priority 1
 000 = Interrupt source is disabled
- bit 3 **Unimplemented:** Read as '0'
- bit 2-0 **U4RXIP<2:0>:** UART4 Receiver Interrupt Priority bits
 111 = Interrupt is priority 7 (highest priority interrupt)
 .
 .
 .
 001 = Interrupt is priority 1
 000 = Interrupt source is disabled

PIC24FJ256DA210 FAMILY

[查询PIC24FJ256DA106供应商](#)

REGISTER 7-40: IPC23: INTERRUPT PRIORITY CONTROL REGISTER 23

| | | | | | | | |
|--------|-----|-----|-----|-----|-----|-----|-------|
| U-0 | U-0 | U-0 | U-0 | U-0 | U-0 | U-0 | U-0 |
| — | — | — | — | — | — | — | — |
| bit 15 | | | | | | | bit 8 |

| | | | | | | | |
|-------|--------|--------|--------|-----|--------|--------|--------|
| U-0 | R/W-1 | R/W-0 | R/W-0 | U-0 | R/W-1 | R/W-0 | R/W-0 |
| — | IC9IP2 | IC9IP1 | IC9IP0 | — | OC9IP2 | OC9IP1 | OC9IP0 |
| bit 7 | | | | | | | bit 0 |

Legend:

R = Readable bit

W = Writable bit

U = Unimplemented bit, read as '0'

-n = Value at POR

'1' = Bit is set

'0' = Bit is cleared

x = Bit is unknown

bit 15-7 **Unimplemented:** Read as '0'

bit 6-4 **IC9IP<2:0>:** Input Capture Channel 9 Interrupt Priority bits

111 = Interrupt is priority 7 (highest priority interrupt)

•

•

•

001 = Interrupt is priority 1

000 = Interrupt source is disabled

bit 3 **Unimplemented:** Read as '0'

bit 2-0 **OC9IP<2:0>:** Output Compare Channel 9 Interrupt Priority bits

111 = Interrupt is priority 7 (highest priority interrupt)

•

•

•

001 = Interrupt is priority 1

000 = Interrupt source is disabled

PIC24FJ256DA210 FAMILY

[查询PIC24FJ256DA106供应商](#)

REGISTER 7-41: IPC25: INTERRUPT PRIORITY CONTROL REGISTER 25

| | | | | | | | |
|--------|-----|-----|-----|-----|-----|-----|-------|
| U-0 | U-0 | U-0 | U-0 | U-0 | U-0 | U-0 | U-0 |
| — | — | — | — | — | — | — | — |
| bit 15 | | | | | | | bit 8 |

| | | | | | | | |
|-------|-----|-----|-----|-----|---------|---------|---------|
| U-0 | U-0 | U-0 | U-0 | U-0 | R/W-1 | R/W-0 | R/W-0 |
| — | — | — | — | — | GFX1IP2 | GFX1IP1 | GFX1IP0 |
| bit 7 | | | | | | bit 0 | |

Legend:

R = Readable bit W = Writable bit U = Unimplemented bit, read as '0'
 -n = Value at POR '1' = Bit is set '0' = Bit is cleared x = Bit is unknown

bit 15-3 **Unimplemented:** Read as '0'
 bit 2-0 **GFX1IP<2:0>:** Graphics 1 Interrupt Priority bits
 111 = Interrupt is priority 7 (highest priority interrupt)
 .
 .
 001 = Interrupt is priority 1
 000 = Interrupt source is disabled

PIC24FJ256DA210 FAMILY

[查询PIC24FJ256DA106供应商](#)

REGISTER 7-42: INTTREG: INTERRUPT CONTROLLER TEST REGISTER

| | | | | | | | |
|----------|-----|-------|-----|----------|----------|----------|----------|
| R-0, HSC | U-0 | R/W-0 | U-0 | R-0, HSC | R-0, HSC | R-0, HSC | R-0, HSC |
| CPUIRQ | — | VHOLD | — | ILR3 | ILR2 | ILR1 | ILR0 |
| bit 15 | | | | | | | bit 8 |

| | | | | | | | |
|-------|----------|----------|----------|----------|----------|----------|----------|
| U-0 | R-0, HSC | R-0, HSC | R-0, HSC | R-0, HSC | R-0, HSC | R-0, HSC | R-0, HSC |
| — | VECNUM6 | VECNUM5 | VECNUM4 | VECNUM3 | VECNUM2 | VECNUM1 | VECNUM0 |
| bit 7 | | | | | | | bit 0 |

| | |
|-------------------|---------------------------------------|
| Legend: | HSC = Hardware Settable/Clearable bit |
| R = Readable bit | W = Writable bit |
| -n = Value at POR | '1' = Bit is set |
| | '0' = Bit is cleared |
| | x = Bit is unknown |
| | U = Unimplemented bit, read as '0' |

- bit 15 **CPUIRQ:** Interrupt Request from Interrupt Controller CPU bit
 1 = An interrupt request has occurred but has not yet been Acknowledged by the CPU; this happens when the CPU priority is higher than the interrupt priority
 0 = No interrupt request is unacknowledged
- bit 14 **Unimplemented:** Read as '0'
- bit 13 **VHOLD:** Vector Number Capture Configuration bit
 1 = The VECNUM bits contain the value of the highest priority pending interrupt
 0 = The VECNUM bits contain the value of the last Acknowledged interrupt (i.e., the last interrupt that has occurred with higher priority than the CPU, even if other interrupts are pending)
- bit 12 **Unimplemented:** Read as '0'
- bit 11-8 **ILR<3:0>:** New CPU Interrupt Priority Level bits
 1111 = CPU Interrupt Priority Level is 15
 .
 .
 .
 0001 = CPU Interrupt Priority Level is 1
 0000 = CPU Interrupt Priority Level is 0
- bit 7 **Unimplemented:** Read as '0'
- bit 6-0 **VECNUM<5:0>:** Vector Number of Pending Interrupt or Last Acknowledged Interrupt bits
 VHOLD = 1: The VECNUM bits indicate the vector number (from 0 to 118) of the last interrupt to occur
 VHOLD = 0: The VECNUM bits indicate the vector number (from 0 to 118) of the interrupt request currently being handled

PIC24FJ256DA210 FAMILY

[查询PIC24FJ256DA106供应商](#)

7.4 Interrupt Setup Procedures

7.4.1 INITIALIZATION

To configure an interrupt source:

1. Set the NSTDIS (INTCON1<15>) control bit if nested interrupts are not desired.
2. Select the user-assigned priority level for the interrupt source by writing the control bits in the appropriate IPCx register. The priority level will depend on the specific application and type of interrupt source. If multiple priority levels are not desired, the IPCx register control bits for all enabled interrupt sources may be programmed to the same non-zero value.

Note: At a device Reset, the IPCx registers are initialized, such that all user interrupt sources are assigned to priority level 4.

3. Clear the interrupt flag status bit associated with the peripheral in the associated IFSx register.
4. Enable the interrupt source by setting the interrupt enable control bit associated with the source in the appropriate IECx register.

7.4.2 INTERRUPT SERVICE ROUTINE (ISR)

The method that is used to declare an Interrupt Service Routine (ISR) and initialize the IVT with the correct vector address will depend on the programming language (i.e., 'C' or assembler) and the language development toolsuite that is used to develop the application. In general, the user must clear the interrupt flag in the appropriate IFSx register for the source of the interrupt that the ISR handles. Otherwise, the ISR will be re-entered immediately after exiting the routine. If the ISR is coded in assembly language, it must be terminated using a `RETFIE` instruction to unstack the saved PC value, SRL value and old CPU priority level.

7.4.3 TRAP SERVICE ROUTINE (TSR)

A Trap Service Routine (TSR) is coded like an ISR, except that the appropriate trap status flag in the INTCON1 register must be cleared to avoid re-entry into the TSR.

7.4.4 INTERRUPT DISABLE

All user interrupts can be disabled using the following procedure:

1. Push the current SR value onto the software stack using the `PUSH` instruction.
2. Force the CPU to priority level 7 by inclusive ORing the value 0Eh with SRL.

To enable user interrupts, the `POP` instruction may be used to restore the previous SR value.

Note that only user interrupts with a priority level of 7 or less can be disabled. Trap sources (Level 8-15) cannot be disabled.

The `DISI` instruction provides a convenient way to disable interrupts of priority levels, 1-6, for a fixed period of time. Level 7 interrupt sources are not disabled by the `DISI` instruction.

PIC24FJ256DA210 FAMILY

[查询PIC24FJ256DA106供应商](#)

8.0 OSCILLATOR CONFIGURATION

Note: This data sheet summarizes the features of this group of PIC24F devices. It is not intended to be a comprehensive reference source. For more information, refer to the “PIC24F Family Reference Manual”, Section 6. “Oscillator” (DS39700). The information in this data sheet supersedes the information in the FRM.

The oscillator system for PIC24FJ256DA210 family devices has the following features:

- A total of four external and internal oscillator options as clock sources, providing 11 different clock modes

- An on-chip PLL block to boost internal operating frequency on select internal and external oscillator sources, and to provide a precise clock source for peripherals, such as USB and graphics
- Software controllable switching between various clock sources
- Software controllable postscaler for selective clocking of CPU for system power savings
- A Fail-Safe Clock Monitor (FSCM) that detects clock failure and permits safe application recovery or shutdown
- A separate and independently configurable system clock output for synchronizing external hardware

A simplified diagram of the oscillator system is shown in Figure 8-1.

FIGURE 8-1: PIC24FJ256DA210 FAMILY CLOCK DIAGRAM

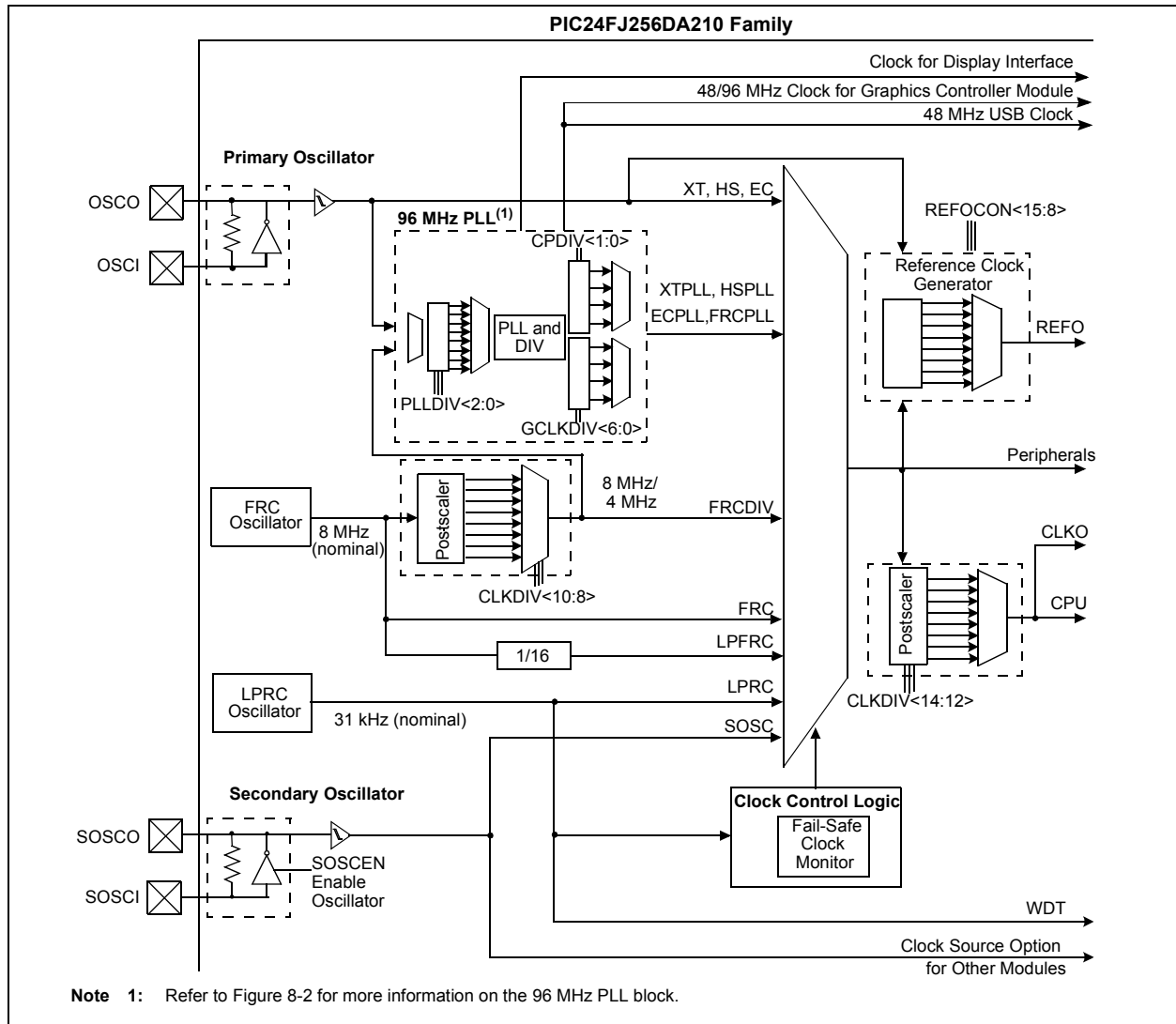

PIC24FJ256DA210 FAMILY

[查询PIC24FJ256DA106供应商](#)

8.1 CPU Clocking Scheme

The system clock source can be provided by one of four sources:

- Primary Oscillator (POSC) on the OSCI and OSCO pins
- Secondary Oscillator (SOSC) on the SOSCI and SOSCO pins
- Fast Internal RC (FRC) Oscillator
- Low-Power Internal RC (LPRC) Oscillator

The primary oscillator and FRC sources have the option of using the internal 24x PLL block, which generates the USB module clock, the Graphics module clock and a separate system clock through the 96 MHz PLL. Refer to **Section 8.5 “96 MHz PLL Block”** for additional information.

The internal FRC provides an 8 MHz clock source. It can optionally be reduced by the programmable clock divider to provide a range of system clock frequencies.

The selected clock source generates the processor and peripheral clock sources. The processor clock source is divided by two to produce the internal instruction cycle clock, Fcy. In this document, the instruction cycle clock is also denoted by Fosc/2. The internal instruction cycle clock, Fosc/2, can be provided on the OSCO I/O pin for some operating modes of the primary oscillator.

8.2 Initial Configuration on POR

The oscillator source (and operating mode) that is used at a device Power-on Reset (POR) event is selected using Configuration bit settings. The oscillator Configuration bit settings are located in the Configuration registers in the program memory (refer to **Section 27.1 “Configuration Bits”** for further details). The Primary Oscillator Configuration bits, POSCMD<1:0> (Configuration Word 2<1:0>) and the Initial Oscillator Select Configuration bits, FNOSC<2:0> (Configuration Word 2<10:8>), select the oscillator source that is used at a POR. The FRC primary oscillator with postscaler (FRCDIV) is the default (unprogrammed) selection. The secondary oscillator, or one of the internal oscillators, may be chosen by programming these bit locations.

The Configuration bits allow users to choose between the various clock modes, shown in Table 8-1.

8.2.1 CLOCK SWITCHING MODE CONFIGURATION BITS

The FCKSM Configuration bits (Configuration Word 2<7:6>) are used to jointly configure device clock switching and the Fail-Safe Clock Monitor (FSCM). Clock switching is enabled only when FCKSM1 is programmed ('0'). The FSCM is enabled only when FCKSM<1:0> are both programmed ('00').

TABLE 8-1: CONFIGURATION BIT VALUES FOR CLOCK SELECTION

| Oscillator Mode | Oscillator Source | POSCMD<1:0> | FNOSC<2:0> | Notes |
|---|-------------------|-------------|------------|-------------|
| Fast RC Oscillator with Postscaler (FRCDIV) | Internal | 11 | 111 | 1, 2 |
| FRC Oscillator/16 (500 KHz) | Internal | 11 | 110 | 1 |
| Low-Power RC Oscillator (LPRC) | Internal | 11 | 101 | 1 |
| Secondary (Timer1) Oscillator (SOSC) | Secondary | 11 | 100 | 1 |
| Primary Oscillator (XT) with PLL Module (XTPLL) | Primary | 01 | 011 | — |
| Primary Oscillator (EC) with PLL Module (ECPLL) | Primary | 00 | 011 | 1 |
| Primary Oscillator (HS) | Primary | 10 | 010 | — |
| Primary Oscillator (XT) | Primary | 01 | 010 | — |
| Primary Oscillator (EC) | Primary | 00 | 010 | 1 |
| Fast RC Oscillator with PLL Module (FRCPLL) | Internal | 11 | 001 | 1 |
| Fast RC Oscillator (FRC) | Internal | 11 | 000 | 1 |

Note 1: OSCO pin function is determined by the OSCIOFCN Configuration bit.

2: This is the default oscillator mode for an unprogrammed (erased) device.

PIC24FJ256DA210 FAMILY

[查询PIC24FJ256DA106供应商](#)

8.3 Control Registers

The following five Special Function Registers control the operation of the oscillator:

- OSCCON
- CLKDIV
- OSCTUN
- CLKDIV2
- REFOCON

The OSCCON register (Register 8-1) is the main control register for the oscillator. It controls clock source switching and allows the monitoring of clock sources.

The CLKDIV register (Register 8-2) controls the features associated with Doze mode, as well as the postscaler for the FRC oscillator.

The OSCTUN register (Register 8-3) allows the user to fine tune the FRC oscillator over a range of approximately $\pm 1.5\%$.

The CLKDIV2 register (Register 8-4) controls the clock to the display glass, with the frequency ranging from 750 kHz to 96 MHz.

The REFOCON register (Register 8-5) controls the frequency of the reference clock out.

REGISTER 8-1: OSCCON: OSCILLATOR CONTROL REGISTER

| | | | | | | | |
|--------|-------------------------|-------------------------|-------------------------|-----|----------------------|----------------------|----------------------|
| U-0 | R-x, HSC ⁽¹⁾ | R-x, HSC ⁽¹⁾ | R-x, HSC ⁽¹⁾ | U-0 | R/W-x ⁽¹⁾ | R/W-x ⁽¹⁾ | R/W-x ⁽¹⁾ |
| — | COSC2 | COSC1 | COSC0 | — | NOSC2 | NOSC1 | NOSC0 |
| bit 15 | | | | | | | bit 8 |

| | | | | | | | |
|---------|-----------------------|-------------------------|-----|-----------|--------|--------|-------|
| R/S-0 | R/W-0 | R-0, HSC ⁽³⁾ | U-0 | R/C-0, HS | R/W-0 | R/W-0 | R/W-0 |
| CLKLOCK | IOLOCK ⁽²⁾ | LOCK | — | CF | POSCEN | SOSCEN | OSWEN |
| bit 7 | | | | | | | bit 0 |

| | | | |
|----------------------------|-------------------|------------------------------------|---------------------------------------|
| Legend: | C = Clearable bit | S = Settable bit | HSC = Hardware Settable/Clearable bit |
| R = Readable bit | W = Writable bit | U = Unimplemented bit, read as '0' | |
| -n = Value at POR | '1' = Bit is set | '0' = Bit is cleared | x = Bit is unknown |
| HS = Hardware Settable bit | | | |

bit 15 **Unimplemented:** Read as '0'

bit 14-12 **COSC<2:0>:** Current Oscillator Selection bits⁽¹⁾

111 = Fast RC Oscillator with Postscaler (FRCDIV)

110 = Fast RC/16 Oscillator

101 = Low-Power RC Oscillator (LPRC)

100 = Secondary Oscillator (SOSC)

011 = Primary Oscillator with PLL module (XTPLL, HSPLL, ECPLL)

010 = Primary Oscillator (XT, HS, EC)

001 = Fast RC Oscillator with Postscaler and PLL module (FRCPLL)

000 = Fast RC Oscillator (FRC)

bit 11 **Unimplemented:** Read as '0'

Note 1: Reset values for these bits are determined by the FNOSC Configuration bits.

2: The state of the IOLOCK bit can only be changed once an unlocking sequence has been executed. In addition, if the IOL1WAY Configuration bit is '1', once the IOLOCK bit is set, it cannot be cleared.

3: Also resets to '0' during any valid clock switch or whenever a non PLL Clock mode is selected.

PIC24FJ256DA210 FAMILY

[查询PIC24FJ256DA106供应商](#)

REGISTER 8-1: ~~OSCCON~~: OSCILLATOR CONTROL REGISTER (CONTINUED)

- bit 10-8 **NOSC<2:0>**: New Oscillator Selection bits⁽¹⁾
111 = Fast RC Oscillator with Postscaler (FRCDIV)
110 = Fast RC/16 Oscillator
101 = Low-Power RC Oscillator (LPRC)
100 = Secondary Oscillator (SOSC)
011 = Primary Oscillator with PLL module (XTPLL, HSPLL, ECPLL)
010 = Primary Oscillator (XT, HS, EC)
001 = Fast RC Oscillator with Postscaler and PLL module (FRCPLL)
000 = Fast RC Oscillator (FRC)
- bit 7 **CLKLOCK**: Clock Selection Lock Enabled bit
If FSCM is enabled (FCKSM1 = 1):
1 = Clock and PLL selections are locked
0 = Clock and PLL selections are not locked and may be modified by setting the OSWEN bit
If FSCM is disabled (FCKSM1 = 0):
Clock and PLL selections are never locked and may be modified by setting the OSWEN bit.
- bit 6 **IOLOCK**: I/O Lock Enable bit⁽²⁾
1 = I/O lock is active
0 = I/O lock is not active
- bit 5 **LOCK**: PLL Lock Status bit⁽³⁾
1 = PLL module is in lock or PLL module start-up timer is satisfied
0 = PLL module is out of lock, PLL start-up timer is running or PLL is disabled
- bit 4 **Unimplemented**: Read as '0'
- bit 3 **CF**: Clock Fail Detect bit
1 = FSCM has detected a clock failure
0 = No clock failure has been detected
- bit 2 **POSCEN**: Primary Oscillator Sleep Enable bit
1 = Primary Oscillator continues to operate during Sleep mode
0 = Primary Oscillator is disabled during Sleep mode
- bit 1 **SOSCEN**: 32 kHz Secondary Oscillator (SOSC) Enable bit
1 = Enable the Secondary Oscillator
0 = Disable the Secondary Oscillator
- bit 0 **OSWEN**: Oscillator Switch Enable bit
1 = Initiate an oscillator switch to the clock source specified by the NOSC<2:0> bits
0 = Oscillator switch is complete

- Note 1:** Reset values for these bits are determined by the FNOOSC Configuration bits.
2: The state of the IOLOCK bit can only be changed once an unlocking sequence has been executed. In addition, if the IOL1WAY Configuration bit is '1', once the IOLOCK bit is set, it cannot be cleared.
3: Also resets to '0' during any valid clock switch or whenever a non PLL Clock mode is selected.

PIC24FJ256DA210 FAMILY

[查询PIC24FJ256DA106供应商](#)

REGISTER 8-2: CLKDIV: CLOCK DIVIDER REGISTER

| | | | | | | | |
|--------|-------|-------|-------|----------------------|--------|--------|--------|
| R/W-0 | R/W-0 | R/W-0 | R/W-0 | R/W-0 | R/W-0 | R/W-0 | R/W-1 |
| ROI | DOZE2 | DOZE1 | DOZE0 | DOZEN ⁽¹⁾ | RCDIV2 | RCDIV1 | RCDIV0 |
| bit 15 | | | | | | | bit 8 |

| | | | | | | | |
|--------|--------|-------|----------|-----|-----|-----|-------|
| R/W-0 | R/W-0 | R/W-0 | R/W-0 | U-0 | U-0 | U-0 | U-0 |
| CPDIV1 | CPDIV0 | PLLEN | G1CLKSEL | — | — | — | — |
| bit 7 | | | | | | | bit 0 |

Legend:

R = Readable bit W = Writable bit U = Unimplemented bit, read as '0'
 -n = Value at POR '1' = Bit is set '0' = Bit is cleared x = Bit is unknown

- bit 15 **ROI:** Recover on Interrupt bit
 1 = Interrupts clear the DOZEN bit and reset the CPU peripheral clock ratio to 1:1
 0 = Interrupts have no effect on the DOZEN bit
- bit 14-12 **DOZE<2:0>:** CPU Peripheral Clock Ratio Select bits
 111 = 1:128
 110 = 1:64
 101 = 1:32
 100 = 1:16
 011 = 1:8
 010 = 1:4
 001 = 1:2
 000 = 1:1
- bit 11 **DOZEN:** DOZE Enable bit⁽¹⁾
 1 = DOZE<2:0> bits specify the CPU peripheral clock ratio
 0 = CPU peripheral clock ratio is set to 1:1
- bit 10-8 **RCDIV<2:0>:** FRC Postscaler Select bits
 111 = 31.25 kHz (divide by 256)
 110 = 125 kHz (divide by 64)
 101 = 250 kHz (divide by 32)
 100 = 500 kHz (divide by 16)
 011 = 1 MHz (divide by 8)
 010 = 2 MHz (divide by 4)
 001 = 4 MHz (divide by 2)
 000 = 8 MHz (divide by 1)
- bit 7-6 **CPDIV<1:0>:** System Clock Select bits (postscaler select from 32 MHz clock branch)
 11 = 4 MHz (divide by 8)⁽²⁾
 10 = 8 MHz (divide by 4)⁽²⁾
 01 = 16 MHz (divide by 2)
 00 = 32 MHz (divide by 1)

- Note 1:** This bit is automatically cleared when the ROI bit is set and an interrupt occurs.
Note 2: This setting is not allowed while the USB module is enabled.

PIC24FJ256DA210 FAMILY

[查询PIC24FJ256DA106供应商](#)

REGISTER 8-2: ~~CLKDIV~~: CLOCK DIVIDER REGISTER (CONTINUED)

- bit 5 **PLEN:** 96 MHz PLL Enable bit
 The 96 MHz PLL must be enabled when the USB or graphics controller module is enabled. This control bit can be overridden by the PLL96MHZ (Configuration Word 2 <11>) Configuration bit.
 1 = Enable the 96 MHz PLL for USB, graphics controller or HSPLL/ECPLL/FRCPLL operation
 0 = Disable the 96 MHz PLL
- bit 4 **G1CLKSEL:** Display Controller Module Clock Select bit
 1 = Use the 96 MHz clock as a graphics controller module clock
 0 = Use the 48 MHz clock as a graphics controller module clock
- bit 3-0 **Unimplemented:** Read as '0'
- Note 1:** This bit is automatically cleared when the ROI bit is set and an interrupt occurs.
Note 2: This setting is not allowed while the USB module is enabled.

REGISTER 8-3: OSCTUN: FRC OSCILLATOR TUNE REGISTER

| | | | | | | | |
|--------|-----|-----|-----|-----|-----|-----|-------|
| U-0 | U-0 | U-0 | U-0 | U-0 | U-0 | U-0 | U-0 |
| — | — | — | — | — | — | — | — |
| bit 15 | | | | | | | bit 8 |

| | | | | | | | |
|-------|-----|---------------------|---------------------|---------------------|---------------------|---------------------|---------------------|
| U-0 | U-0 | R/W-0 | R/W-0 | R/W-0 | R/W-0 | R/W-0 | R/W-0 |
| — | — | TUN5 ⁽¹⁾ | TUN4 ⁽¹⁾ | TUN3 ⁽¹⁾ | TUN2 ⁽¹⁾ | TUN1 ⁽¹⁾ | TUN0 ⁽¹⁾ |
| bit 7 | | | | | | | bit 0 |

Legend:

| | | |
|-------------------|------------------|--|
| R = Readable bit | W = Writable bit | U = Unimplemented bit, read as '0' |
| -n = Value at POR | '1' = Bit is set | '0' = Bit is cleared x = Bit is unknown |

- bit 15-6 **Unimplemented:** Read as '0'
- bit 5-0 **TUN<5:0>:** FRC Oscillator Tuning bits⁽¹⁾
 011111 = Maximum frequency deviation
 011110 =
 .
 .
 .
 000001 =
 000000 = Center frequency, oscillator is running at factory calibrated frequency
 111111 =
 .
 .
 .
 100001 =
 100000 = Minimum frequency deviation

Note 1: Increments or decrements of TUN<5:0> may not change the FRC frequency in equal steps over the FRC tuning range and may not be monotonic.

PIC24FJ256DA210 FAMILY

[查询PIC24FJ256DA106供应商](#)

REGISTER 8-4: CLKDIV2: CLOCK DIVIDER REGISTER 2

| | | | | | | | |
|-------------------------|-------------------------|-------------------------|-------------------------|-------------------------|-------------------------|-------------------------|-------|
| R/W-0 | R/W-0 | R/W-0 | R/W-0 | R/W-0 | R/W-0 | R/W-0 | U-0 |
| GCLKDIV6 ⁽¹⁾ | GCLKDIV5 ⁽¹⁾ | GCLKDIV4 ⁽¹⁾ | GCLKDIV3 ⁽¹⁾ | GCLKDIV2 ⁽¹⁾ | GCLKDIV1 ⁽¹⁾ | GCLKDIV0 ⁽¹⁾ | — |
| bit 15 | | | | | | | bit 8 |

| | | | | | | | |
|-------|-----|-----|-----|-----|-----|-----|-------|
| U-0 | U-0 | U-0 | U-0 | U-0 | U-0 | U-0 | U-0 |
| — | — | — | — | — | — | — | — |
| bit 7 | | | | | | | bit 0 |

Legend:

R = Readable bit

W = Writable bit

U = Unimplemented bit, read as '0'

-n = Value at all Resets

'1' = Bit is set

'0' = Bit is cleared

x = Bit is unknown

bit 15-9

GCLKDIV<6:0>: Display Module Interface Clock Divider Selection bits⁽¹⁾

(Values are based on a 96 MHz clock source set by G1CLKSEL (CLKDIV<4>) = 1. When the 48 MHz clock source is selected, G1CLKSEL (CLKDIV<4>) = 0; all values are divided by 2.)⁽¹⁾

11111111 = (127) 1.50 MHz (divide by 64)

11111110 = (126) 1.52 MHz (divide by 63)

.

.

.

1100001 = (97) 2.82 MHz (divide by 34)

1100000 = (96) 2.91 MHz (divide by 33); from here, increment the divisor by 1.00

10111111 = (95) 2.95 MHz (divide by 32.50)

.

.

.

1000000 = (65) 5.49 MHz (divide by 17.50)

1000000 = (64) 5.65 MHz (divide by 17.00); from here, increment the divisor by 0.50

01111111 = (63) 5.73 MHz (divide by 16.75)

.

.

.

0000011 = (3) 54.86 MHz (divide by 1.75)

0000010 = (2) 64.00 MHz (divide by 1.5)

0000001 = (1) 76.80 MHz (divide by 1.25); from here, increment the divisor by 0.25

0000000 = (0) 96.00 MHz (divide by 1)

bit 8-0

Unimplemented: Read as '0'

Note 1: These bits take effect only when the 96 MHz PLL is enabled.

PIC24FJ256DA210 FAMILY

[查询PIC24FJ256DA106供应商](#)

8.4 Clock Switching Operation

With few limitations, applications are free to switch between any of the four clock sources (POSC, SOSC, FRC and LPRC) under software control and at any time. To limit the possible side effects that could result from this flexibility, PIC24F devices have a safeguard lock built into the switching process.

Note: The Primary Oscillator mode has three different submodes (XT, HS and EC) which are determined by the POSCMDx Configuration bits. While an application can switch to and from Primary Oscillator mode in software, it cannot switch between the different primary submodes without reprogramming the device.

8.4.1 ENABLING CLOCK SWITCHING

To enable clock switching, the FCKSM1 Configuration bit in CW2 must be programmed to '0'. (Refer to **Section 27.1 "Configuration Bits"** for further details.) If the FCKSM1 Configuration bit is unprogrammed ('1'), the clock switching function and Fail-Safe Clock Monitor function are disabled. This is the default setting.

The NOSCx (OSCCON<10:8>) control bits do not control the clock selection when clock switching is disabled. However, the COSCx (OSCCON<14:12>) control bits will reflect the clock source selected by the FNOSCx Configuration bits.

The OSWEN (OSCCON<0>) control bit has no effect when clock switching is disabled; It is held at '0' at all times.

8.4.2 OSCILLATOR SWITCHING SEQUENCE

At a minimum, performing a clock switch requires this basic sequence:

1. If desired, read the COSCx (OSCCON<14:12>) control bits to determine the current oscillator source.
2. Perform the unlock sequence to allow a write to the OSCCON register high byte.
3. Write the appropriate value to the NOSCx (OSCCON<10:8>) control bits for the new oscillator source.
4. Perform the unlock sequence to allow a write to the OSCCON register low byte.
5. Set the OSWEN bit to initiate the oscillator switch.

Once the basic sequence is completed, the system clock hardware responds automatically as follows:

1. The clock switching hardware compares the COSCx bits with the new value of the NOSCx bits. If they are the same, then the clock switch is a redundant operation. In this case, the OSWEN bit is cleared automatically and the clock switch is aborted.
2. If a valid clock switch has been initiated, the LOCK (OSCCON<5>) and CF (OSCCON<3>) bits are cleared.
3. The new oscillator is turned on by the hardware if it is not currently running. If a crystal oscillator must be turned on, the hardware will wait until the OST expires. If the new source is using the PLL, then the hardware waits until a PLL lock is detected (LOCK = 1).
4. The hardware waits for 10 clock cycles from the new clock source and then performs the clock switch.
5. The hardware clears the OSWEN bit to indicate a successful clock transition. In addition, the NOSCx bit values are transferred to the COSCx bits.
6. The old clock source is turned off at this time, with the exception of LPRC (if WDT or FSCM are enabled) or SOSC (if SOSCEM remains set).

Note 1: The processor will continue to execute code throughout the clock switching sequence. Timing-sensitive code should not be executed during this time.

- 2: Direct clock switches between any Primary Oscillator mode with PLL and FRCPLL modes are not permitted. This applies to clock switches in either direction. In these instances, the application must switch to FRC mode as a transition clock source between the two PLL modes.

PIC24FJ256DA210 FAMILY

[查询PIC24FJ256DA106供应商](#)

A recommended code sequence for a clock switch includes the following:

1. Disable interrupts during the OSCCON register unlock and write sequence.
2. Execute the unlock sequence for the OSCCON high byte by writing 78h and 9Ah to OSCCON<15:8> in two back-to-back instructions.
3. Write new oscillator source to the NOSCx bits in the instruction immediately following the unlock sequence.
4. Execute the unlock sequence for the OSCCON low byte by writing 46h and 57h to OSCCON<7:0> in two back-to-back instructions.
5. Set the OSWEN bit in the instruction immediately following the unlock sequence.
6. Continue to execute code that is not clock-sensitive (optional).
7. Invoke an appropriate amount of software delay (cycle counting) to allow the selected oscillator and/or PLL to start and stabilize.
8. Check to see if OSWEN is '0'. If it is, the switch was successful. If OSWEN is still set, then check the LOCK bit to determine the cause of failure.

The core sequence for unlocking the OSCCON register and initiating a clock switch is shown in Example 8-1.

EXAMPLE 8-1: BASIC CODE SEQUENCE FOR CLOCK SWITCHING IN ASSEMBLY

```
;Place the new oscillator selection in W0
;OSCCONH (high byte) Unlock Sequence
MOV      #OSCCONH, w1
MOV      #0x78, w2
MOV      #0x9A, w3
MOV.b    w2, [w1]
MOV.b    w3, [w1]
;Set new oscillator selection
MOV.b    WREG, OSCCONH
;OSCCONL (low byte) unlock sequence
MOV      #OSCCONL, w1
MOV      #0x46, w2
MOV      #0x57, w3
MOV.b    w2, [w1]
MOV.b    w3, [w1]
;Start oscillator switch operation
BSET     OSCCON,#0
```

8.5 96 MHz PLL Block

The 96 MHz PLL block is implemented to generate the stable 48 MHz clock required for full-speed USB operation, a programmable clock output for the graphics controller module and the system clock from the same oscillator source. The 96 MHz PLL block is shown in Figure 8-2.

The 96 MHz PLL block requires a 4 MHz input signal; it uses this to generate a 96 MHz signal from a fixed, 24x PLL. This is, in turn, divided into three branches. The first branch generates the USB clock, the second branch generates the system clock and the third branch generates the graphics clock. The 96 MHz PLL block can be enabled and disabled using the PLL96MHZ Configuration bit (Configuration Word<11>) or through the PLEN (CLKDIV<5>) control bit when the PLL96MHZ Configuration bit is not set. Note that the PLL96MHZ Configuration bit and PLEN register bit are available only for PIC24F devices with USB and graphics controller modules.

The 96 MHz PLL prescaler does not automatically sense the incoming oscillator frequency. The user must manually configure the PLL divider to generate the required 4 MHz output, using the PLLDIV<2:0> Configuration bits (Configuration Word 2<14:12> in most devices).

PIC24FJ256DA210 FAMILY

查询PIC24FJ256DA106供应商

FIGURE 8-2: 96 MHz PLL BLOCK

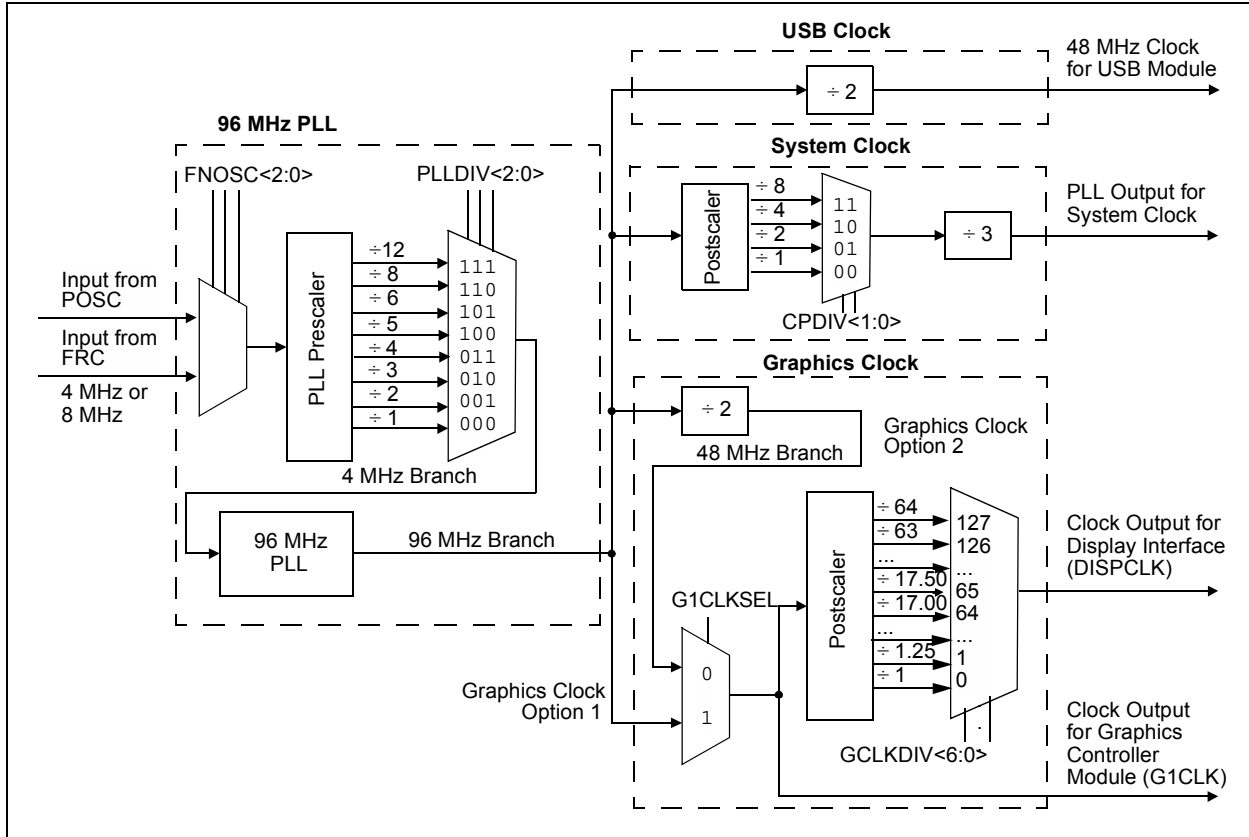

8.5.1 SYSTEM CLOCK GENERATION

The system clock is generated from the 96 MHz branch using a configurable postscaler/divider to generate a range of frequencies for the system clock multiplexer. The output of the multiplexer is further passed through a fixed divide-by-3 divider and the final output is used

as the system clock. Figure 8-2 shows this logic in the system clock sub-block. Since the source is a 96 MHz signal, the possible system clock frequencies are listed in Table 8-2. The available system clock options are always the same, regardless of the setting of the PLLDIV Configuration bits.

TABLE 8-2: SYSTEM CLOCK OPTIONS FOR 96 MHz PLL BLOCK

| MCU Clock Division (CPDIV<1:0>) | System Clock Frequency (Instruction Rate in MIPS) |
|---------------------------------|---|
| None (00) | 32 MHz (16) |
| ÷2 (01) | 16 MHz (8) |
| ÷4 (10) | 8 MHz (4) ⁽¹⁾ |
| ÷8 (11) | 4 MHz (2) ⁽¹⁾ |

Note 1: These options are not compatible with USB operation. They may be used whenever the PLL branch is selected and the USB module is disabled.

PIC24FJ256DA210 FAMILY

[查询PIC24FJ256DA106供应商](#)

8.5.2 USB CLOCK GENERATION

In the USB-On-The-Go module in PIC24FJ256DA210 family of devices, the primary oscillator with the PLL block can be used as a valid clock source for USB operation. The FRC oscillator (implemented with $\pm 0.25\%$ accuracy) can be combined with a PLL block, providing another option for a valid USB clock source. There is no provision to provide a separate external 48 MHz clock to the USB module. The USB module sources its

clock signal from 96 MHz PLL. Due to the requirement that a 4 MHz input must be provided to generate the 96 MHz signal, the oscillator operation is limited to a range of possible values. Table 8-3 shows the valid oscillator configurations (i.e., ECPLL, HSPLL, XTPLL and FRCPLL) for USB operation. This sets the correct PLLDIV configuration for the specified oscillator frequency and the output frequency of the USB clock branch is always 48 MHz.

TABLE 8-3: VALID OSCILLATOR CONFIGURATIONS FOR USB OPERATIONS

| Input Oscillator Frequency | Clock Mode | PLL Division (PLLDIV<2:0>) |
|----------------------------|-----------------------------|----------------------------|
| 48 MHz | ECPLL | $\div 12$ (111) |
| 32 MHz | HSPLL, ECPLL | $\div 8$ (110) |
| 24 MHz | HSPLL, ECPLL | $\div 6$ (101) |
| 20 MHz | HSPLL, ECPLL | $\div 5$ (100) |
| 16 MHz | HSPLL, ECPLL | $\div 4$ (011) |
| 12 MHz | HSPLL, ECPLL | $\div 3$ (010) |
| 8 MHz | ECPLL, HSPLL, XTPLL, FRCPLL | $\div 2$ (001) |
| 4 MHz | ECPLL, HSPLL, XTPLL, FRCPLL | $\div 1$ (000) |

Note: For USB devices, the use of a primary oscillator or external clock source, with a frequency above 32 MHz, does not imply that the device's system clock can be run at the same speed when the USB module is not used. The maximum system clock for all PIC24F devices is 32 MHz.

8.5.3 CONSIDERATIONS FOR USB OPERATION

When using the USB On-The-Go module in PIC24FJ256DA210 family devices, users must always observe these rules in configuring the system clock:

- For USB operation, the selected clock source (EC, HS or XT) must meet the USB clock tolerance requirements.
- The Primary Oscillator/PLL modes are the only oscillator configurations that permit USB operation. There is no provision to provide a separate external clock source to the USB module.
- While the FRCPLL Oscillator mode is used for USB applications, users must always ensure that the FRC source is configured to provide a frequency of 4 MHz or 8 MHz ($RCDIV<2:0> = 001$ or 000) and that the USB PLL prescaler is configured appropriately.

All other oscillator modes are available; however, USB operation is not possible when these modes are selected. They may still be useful in cases where other power levels of operation are desirable and the USB module is not needed (e.g., the application is sleeping and waiting for a bus attachment).

8.5.4 GRAPHICS CLOCK GENERATION

Two stable clock signals are generated for the graphics controller in the PIC24FJ256DA210 family of devices. The first clock is for the graphics controller module logic and the second clock is for the display module interface logic that generates the signals for the display glass. Figure 8-2 shows this logic in the graphics clock sub-block. Both clock signals are generated either from the Graphics Clock Option 1 (96 MHz branch) or the Graphics Clock Option 2 (48 MHz branch). Selection is set in the multiplexer using the G1CLKSEL (CLKDIV<4>) control bit. Graphics controller module logic directly uses the output of that multiplexer while the display module interface clock is further conditioned through a postscaler to generate 128 possible frequencies. The final clock output signal is selected through a multiplexer using the GCLKDIV<6:0> (CLKDIV2<15:9>) control bits. The 128 selections vary in increments of 0.25, 0.5, and 1.0. Refer to Table 8-4 for details. Note that for applications that use the graphics controller (GFX) module, the 96 MHz PLL must be enabled.

PIC24FJ256DA210 FAMILY

查询PIC24FJ256DA106供应商

TABLE 8-4: DISPLAY MODULE CLOCK FREQUENCY DIVISION

| GCLKDIV<6:0> | Frequency Divisor | Display Module Clock Frequency 96 MHz Input (48 MHz Input) |
|--------------|-----------------------------------|---|
| 0000000 | 1 | 96 MHz (48 MHz) |
| 0000001 | 1.25 (start incrementing by 0.25) | 76.80 MHz (38.4 MHz) |
| 0000010 | 1.5 | 64 MHz (32 MHz) |
| ... | ... | ... |
| 0111111 | 16.75 | 5.73 MHz (2.86 MHz) |
| 1000000 | 17 | 5.65 MHz (2.82 MHz) |
| 1000001 | 17.5 (start incrementing by 0.5) | 5.49 MHz (2.74 MHz) |
| 1000010 | 18 | 5.33 MHz (2.66 MHz) |
| ... | ... | ... |
| 1011111 | 32.5 | 2.95 MHz (1.47 MHz) |
| 1100000 | 33 | 2.91 MHz (1.45 MHz) |
| 1100001 | 34 (start incrementing by 1) | 2.82 MHz (1.41 MHz) |
| 1100010 | 35 | 2.74 MHz (1.37 MHz) |
| ... | ... | ... |
| 1111110 | 63 | 1.52 MHz (762 kHz) |
| 1111111 | 64 | 1.50 MHz (750 kHz) |

8.6 Reference Clock Output

In addition to the CLK0 output ($F_{osc}/2$) available in certain oscillator modes, the device clock in the PIC24FJ256DA210 family devices can also be configured to provide a reference clock output signal to a port pin. This feature is available in all oscillator configurations and allows the user to select a greater range of clock submultiples to drive external devices in the application.

This reference clock output is controlled by the REFOCON register (Register 8-5). Setting the ROEN bit (REFOCON<15>) makes the clock signal available on the REFO pin. The RODIV bits (REFOCON<11:8>) enable the selection of 16 different clock divider options.

The ROSSLP and ROSEL bits (REFOCON<13:12>) control the availability of the reference output during Sleep mode. The ROSEL bit determines if the oscillator on OSCI and OSC0, or the current system clock source, is used for the reference clock output. The ROSSLP bit determines if the reference source is available on REFO when the device is in Sleep mode.

To use the reference clock output in Sleep mode, both the ROSSLP and ROSEL bits must be set. The device clock must also be configured for one of the primary modes (EC, HS or XT); otherwise, if the POSCEN bit is not also set, the oscillator on OSCI and OSC0 will be powered down when the device enters Sleep mode. Clearing the ROSEL bit allows the reference output frequency to change as the system clock changes during any clock switches.

PIC24FJ256DA210 FAMILY

[查询PIC24FJ256DA106供应商](#)

REGISTER 8-5: REFOCON: REFERENCE OSCILLATOR CONTROL REGISTER

| | | | | | | | |
|--------|-----|--------|----------------------|--------|--------|--------|--------|
| R/W-0 | U-0 | R/W-0 | R/W-0 | R/W-0 | R/W-0 | R/W-0 | R/W-0 |
| ROEN | — | ROSSLP | ROSEL ⁽¹⁾ | RODIV3 | RODIV2 | RODIV1 | RODIV0 |
| bit 15 | | | | | | | bit 8 |

| | | | | | | | |
|-------|-----|-----|-----|-----|-----|-----|-------|
| U-0 | U-0 | U-0 | U-0 | U-0 | U-0 | U-0 | U-0 |
| — | — | — | — | — | — | — | — |
| bit 7 | | | | | | | bit 0 |

Legend:

R = Readable bit W = Writable bit U = Unimplemented bit, read as '0'
 -n = Value at POR '1' = Bit is set '0' = Bit is cleared x = Bit is unknown

- bit 15 **ROEN:** Reference Oscillator Output Enable bit
 1 = Reference oscillator enabled on REFO pin
 0 = Reference oscillator disabled
- bit 14 **Unimplemented:** Read as '0'
- bit 13 **ROSSLP:** Reference Oscillator Output Stop in Sleep bit
 1 = Reference oscillator continues to run in Sleep
 0 = Reference oscillator is disabled in Sleep
- bit 12 **ROSEL:** Reference Oscillator Source Select bit⁽¹⁾
 1 = Primary oscillator used as the base clock
 0 = System clock used as the base clock; base clock reflects any clock switching of the device
- bit 11-8 **RODIV<3:0>:** Reference Oscillator Divisor Select bits
 1111 = Base clock value divided by 32,768
 1110 = Base clock value divided by 16,384
 1101 = Base clock value divided by 8,192
 1100 = Base clock value divided by 4,096
 1011 = Base clock value divided by 2,048
 1010 = Base clock value divided by 1,024
 1001 = Base clock value divided by 512
 1000 = Base clock value divided by 256
 0111 = Base clock value divided by 128
 0110 = Base clock value divided by 64
 0101 = Base clock value divided by 32
 0100 = Base clock value divided by 16
 0011 = Base clock value divided by 8
 0010 = Base clock value divided by 4
 0001 = Base clock value divided by 2
 0000 = Base clock value
- bit 7-0 **Unimplemented:** Read as '0'

Note 1: Note that the crystal oscillator must be enabled using the FOSC<2:0> bits; the crystal maintains the operation in Sleep mode.

PIC24FJ256DA210 FAMILY

[查询PIC24FJ256DA106供应商](#)

NOTES:

PIC24FJ256DA210 FAMILY

[查询PIC24FJ256DA106供应商](#)

9.0 POWER-SAVING FEATURES

Note: This data sheet summarizes the features of this group of PIC24F devices. It is not intended to be a comprehensive reference source. For more information, refer to the “PIC24F Family Reference Manual”, **Section 10. “Power-Saving Features”** (DS39698). The information in this data sheet supersedes the information in the FRM.

The PIC24FJ256DA210 family of devices provides the ability to manage power consumption by selectively managing clocking to the CPU and the peripherals. In general, a lower clock frequency and a reduction in the number of circuits being clocked constitutes lower consumed power. All PIC24F devices manage power consumption in four different ways:

- Clock Frequency
- Instruction-Based Sleep and Idle modes
- Software Controlled Doze mode
- Selective Peripheral Control in Software

Combinations of these methods can be used to selectively tailor an application’s power consumption, while still maintaining critical application features, such as timing-sensitive communications.

9.1 Clock Frequency and Clock Switching

PIC24F devices allow for a wide range of clock frequencies to be selected under application control. If the system clock configuration is not locked, users can choose low-power or high-precision oscillators by simply changing the NOSC bits. The process of changing a system clock during operation, as well as limitations to the process, are discussed in more detail in **Section 8.0 “Oscillator Configuration”**.

9.2 Instruction-Based Power-Saving Modes

PIC24F devices have two special power-saving modes that are entered through the execution of a special `PWRSVAV` instruction. Sleep mode stops clock operation and halts all code execution; Idle mode halts the CPU and code execution, but allows peripheral modules to continue operation. The assembly syntax of the `PWRSVAV` instruction is shown in Example 9-1.

Sleep and Idle modes can be exited as a result of an enabled interrupt, WDT time-out or a device Reset. When the device exits these modes, it is said to “wake-up”.

9.2.1 SLEEP MODE

Sleep mode has these features:

- The system clock source is shut down. If an on-chip oscillator is used, it is turned off.
- The device current consumption will be reduced to a minimum, provided that no I/O pin is sourcing current.
- The Fail-Safe Clock Monitor (FSCM) does not operate during Sleep mode since the system clock source is disabled.
- The LPRC clock will continue to run in Sleep mode if the WDT is enabled.
- The WDT, if enabled, is automatically cleared prior to entering Sleep mode.
- Some device features or peripherals may continue to operate in Sleep mode. This includes items such as the input change notification on the I/O ports or peripherals that use an external clock input. Any peripheral that requires the system clock source for its operation will be disabled in Sleep mode. Users can opt to make the voltage regulator enter standby mode on entering Sleep mode by clearing the `VREGS` bit (`RCON<8>`). This will decrease current consumption but will add a delay, `TVREG`, to the wake-up time. For this reason, applications that do not use the voltage regulator should set this bit.

The device will wake-up from Sleep mode on any of the these events:

- On any interrupt source that is individually enabled
- On any form of device Reset
- On a WDT time-out

On wake-up from sleep, the processor will restart with the same clock source that was active when Sleep mode was entered.

EXAMPLE 9-1: PWRSVAV INSTRUCTION SYNTAX

```
PWRSVAV #0 ; Put the device into SLEEP mode
PWRSVAV #1 ; Put the device into IDLE mode
```

PIC24FJ256DA210 FAMILY

[查询PIC24FJ256DA106供应商](#)

9.2.2 IDLE MODE

Idle mode has these features:

- The CPU will stop executing instructions.
- The WDT is automatically cleared.
- The system clock source remains active. By default, all peripheral modules continue to operate normally from the system clock source, but can also be selectively disabled (see **Section 9.4 “Selective Peripheral Module Control”**).
- If the WDT or FSCM is enabled, the LPRC will also remain active.

The device will wake from Idle mode on any of these events:

- Any interrupt that is individually enabled.
- Any device Reset.
- A WDT time-out.

On wake-up from Idle, the clock is reapplied to the CPU and instruction execution begins immediately, starting with the instruction following the `PWRSAV` instruction or the first instruction in the ISR.

9.2.3 INTERRUPTS COINCIDENT WITH POWER SAVE INSTRUCTIONS

Any interrupt that coincides with the execution of a `PWRSAV` instruction will be held off until entry into Sleep or Idle mode has completed. The device will then wake-up from Sleep or Idle mode.

9.3 Doze Mode

Generally, changing clock speed and invoking one of the power-saving modes are the preferred strategies for reducing power consumption. There may be circumstances, however, where this is not practical. For example, it may be necessary for an application to maintain uninterrupted synchronous communication, even while it is doing nothing else. Reducing system clock speed may introduce communication errors, while using a power-saving mode may stop communications completely.

Doze mode is a simple and effective alternative method to reduce power consumption while the device is still executing code. In this mode, the system clock continues to operate from the same source and at the same speed. Peripheral modules continue to be clocked at the same speed while the CPU clock speed is reduced. Synchronization between the two clock domains is maintained, allowing the peripherals to access the SFRs while the CPU executes code at a slower rate.

Doze mode is enabled by setting the `DOZEN` bit (`CLKDIV<11>`). The ratio between peripheral and core clock speed is determined by the `DOZE<2:0>` bits (`CLKDIV<14:12>`). There are eight possible configurations, from 1:1 to 1:128, with 1:1 being the default.

It is also possible to use Doze mode to selectively reduce power consumption in event driven applications. This allows clock-sensitive functions, such as synchronous communications, to continue without interruption while the CPU idles, waiting for something to invoke an interrupt routine. Enabling the automatic return to full-speed CPU operation on interrupts is enabled by setting the `ROI` bit (`CLKDIV<15>`). By default, interrupt events have no effect on Doze mode operation.

9.4 Selective Peripheral Module Control

Idle and Doze modes allow users to substantially reduce power consumption by slowing or stopping the CPU clock. Even so, peripheral modules still remain clocked, and thus, consume power. There may be cases where the application needs what these modes do not provide: the allocation of power resources to CPU processing with minimal power consumption from the peripherals.

PIC24F devices address this requirement by allowing peripheral modules to be selectively disabled, reducing or eliminating their power consumption. This can be done with two control bits:

- The Peripheral Enable bit, generically named, “`XXXEN`”, located in the module’s main control SFR.
- The Peripheral Module Disable (PMD) bit, generically named, “`XXXMD`”, located in one of the PMD control registers.

Both bits have similar functions in enabling or disabling its associated module. Setting the PMD bit for a module disables all clock sources to that module, reducing its power consumption to an absolute minimum. In this state, the control and status registers associated with the peripheral will also be disabled, so writes to those registers will have no effect and read values will be invalid. Many peripheral modules have a corresponding PMD bit.

In contrast, disabling a module by clearing its `XXXEN` bit disables its functionality, but leaves its registers available to be read and written to. This reduces power consumption, but not by as much as setting the PMD bit does. Most peripheral modules have an enable bit; exceptions include input capture, output compare and RTCC.

To achieve more selective power savings, peripheral modules can also be selectively disabled when the device enters Idle mode. This is done through the control bit of the generic name format, “`XXXIDL`”. By default, all modules that can operate during Idle mode will do so. Using the disable on Idle feature allows further reduction of power consumption during Idle mode, enhancing power savings for extremely critical power applications.

PIC24FJ256DA210 FAMILY

[查询PIC24FJ256DA106供应商](#)

10.0 I/O PORTS

Note: This data sheet summarizes the features of this group of PIC24F devices. It is not intended to be a comprehensive reference source. For more information, refer to the “PIC24F Family Reference Manual”, Section 12. “I/O Ports with Peripheral Pin Select (PPS)” (DS39711). The information in this data sheet supersedes the information in the FRM.

All of the device pins (except VDD, VSS, $\overline{\text{MCLR}}$ and OSC1/CLKI) are shared between the peripherals and the parallel I/O ports. All I/O input ports feature Schmitt Trigger (ST) inputs for improved noise immunity.

10.1 Parallel I/O (PIO) Ports

A parallel I/O port that shares a pin with a peripheral is, in general, subservient to the peripheral. The peripheral's output buffer data and control signals are provided to a pair of multiplexers. The multiplexers select whether the peripheral or the associated port has ownership of the output data and control signals of the I/O pin. The logic also prevents “loop through”, in which a port's digital output can drive the input of a peripheral that shares the same pin. Figure 10-1 shows how ports are shared with other peripherals and the associated I/O pin to which they are connected.

When a peripheral is enabled and the peripheral is actively driving an associated pin, the use of the pin as a general purpose output pin is disabled. The I/O pin may be read, but the output driver for the parallel port bit will be disabled. If a peripheral is enabled, but the peripheral is not actively driving a pin, that pin may be driven by a port.

All port pins have three registers directly associated with their operation as digital I/O and one register associated with their operation as analog input. The Data Direction register (TRISx) determines whether the pin is an input or an output. If the data direction bit is a ‘1’, then the pin is an input. All port pins are defined as inputs after a Reset. Reads from the Output Latch register (LATx), read the latch; writes to the latch, write the latch. Reads from the port (PORTx), read the port pins; writes to the port pins, write the latch.

Any bit and its associated data and control registers that are not valid for a particular device will be disabled. That means the corresponding LATx and TRISx registers, and the port pin will read as zeros.

When a pin is shared with another peripheral or function that is defined as an input only, it is regarded as a dedicated port because there is no other competing source of inputs.

FIGURE 10-1: BLOCK DIAGRAM OF A TYPICAL SHARED PORT STRUCTURE

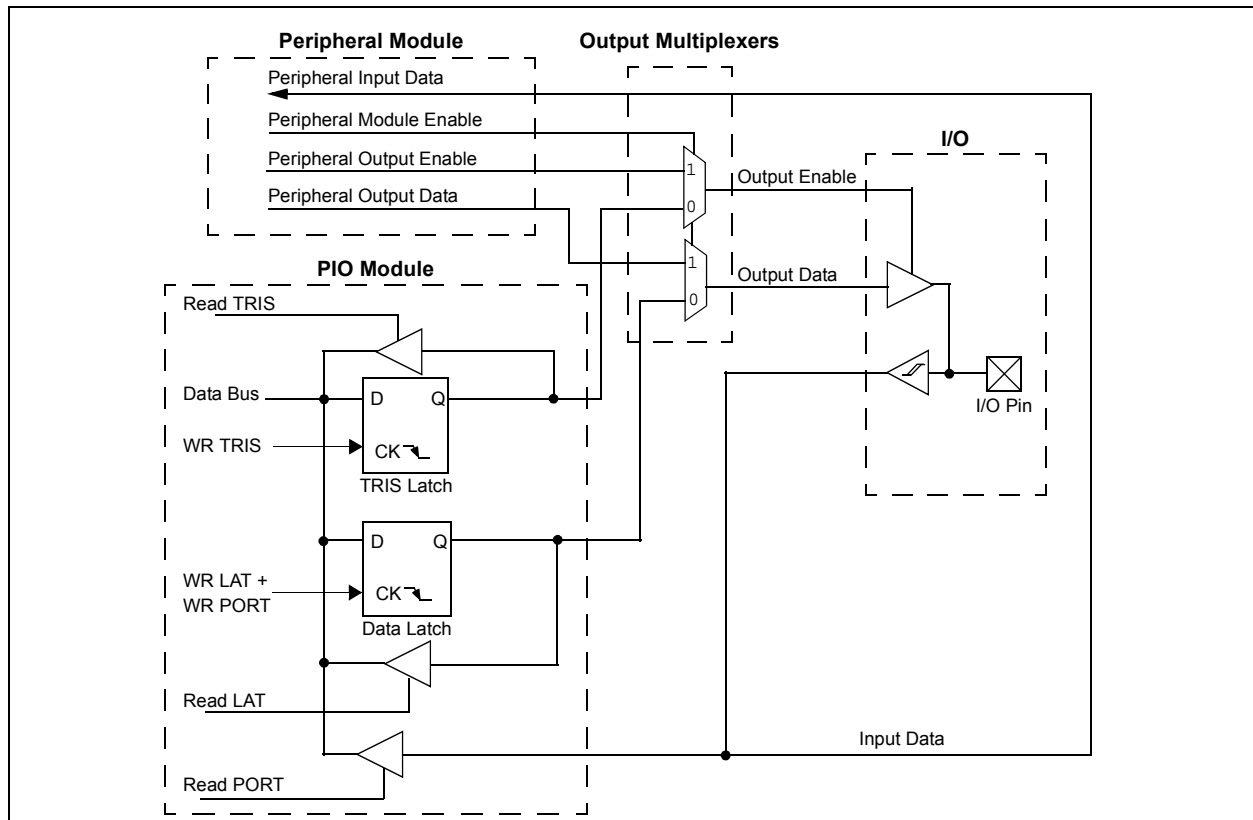

PIC24FJ256DA210 FAMILY

[查询PIC24FJ256DA106供应商](#)

10.1.1 I/O PORT WRITE/READ TIMING

One instruction cycle is required between a port direction change or port write operation and a read operation of the same port. Typically, this instruction would be a `NOP`.

10.1.2 OPEN-DRAIN CONFIGURATION

In addition to the `PORT`, `LAT` and `TRIS` registers for data control, each port pin can also be individually configured for either a digital or open-drain output. This is controlled by the Open-Drain Control register, `ODCx`, associated with each port. Setting any of the bits configures the corresponding pin to act as an open-drain output.

The open-drain feature allows the generation of outputs higher than V_{DD} (e.g., 5V) on any desired digital only pins by using external pull-up resistors. The maximum open-drain voltage allowed is the same as the maximum V_{IH} specification.

10.1.3 CONFIGURING D+ AND D- PINS (RG2 AND RG3)

The input buffers of the `RG2` and `RG3` pins are by default, tri-stated. To use these pins as input pins, the `UTRDIS` bit (`U1CNFG2<0>`) should be set which enables the input buffers on these pins.

10.2 Configuring Analog Port Pins (ANSEL)

The `ANSx` and `TRISx` registers control the operation of the pins with analog function. Each port pin with analog function is associated with one of the `ANS` bits (see Register 10-1 through Register 10-7), which decides if the pin function should be analog or digital. Refer to Table 10-1 for detailed behavior of the pin for different `ANSx` and `TRISx` bit settings.

When reading the `PORT` register, all pins configured as analog input channels will read as cleared (a low level).

10.2.1 ANALOG INPUT PINS AND VOLTAGE CONSIDERATIONS

The voltage tolerance of pins used as device inputs is dependent on the pin's input function. Pins that are used as digital only inputs are able to handle DC voltages of up to 5.5V, a level typical for digital logic circuits. In contrast, pins that also have analog input functions of any kind can only tolerate voltages up to V_{DD} . Voltage excursions beyond V_{DD} on these pins should always be avoided. Table 10-2 summarizes the input capabilities. Refer to **Section 30.1 "DC Characteristics"** for more details.

TABLE 10-1: CONFIGURING ANALOG/DIGITAL FUNCTION OF AN I/O PIN

| Pin Function | ANSx Setting | TRISx Setting | Comments |
|----------------|--------------|---------------|--|
| Analog Input | 1 | 1 | It is recommended to keep <code>ANSx = 1</code> . |
| Analog Output | 1 | 1 | It is recommended to keep <code>ANSx = 1</code> . |
| Digital Input | 0 | 1 | Firmware must wait at least one instruction cycle after configuring a pin as a digital input before a valid input value can be read. |
| Digital Output | 0 | 0 | Make sure to disable the analog output function on the pin if any is present. |

TABLE 10-2: INPUT VOLTAGE LEVELS FOR PORT OR PIN TOLERATED DESCRIPTION INPUT

| Port or Pin | Tolerated Input | Description |
|--|-----------------|---|
| PORTA ⁽¹⁾ <10:9, 7:6> | VDD | Only VDD input levels are tolerated. |
| PORTB<15:0> | | |
| PORTC ⁽¹⁾ <15:12, 4> | | |
| PORTD<7:6> | | |
| PORTE ⁽¹⁾ <9> | | |
| PORTF<0> | | |
| PORTG<9:6, 3:2> | 5.5V | Tolerates input levels above VDD, useful for most standard logic. |
| PORTA ⁽¹⁾ <15:14, 5:0> | | |
| PORTC ⁽¹⁾ <3:1> | | |
| PORTD ⁽¹⁾ <15:8, 5:0> | | |
| PORTE ⁽¹⁾ <8:0> | | |
| PORTF ⁽¹⁾ <13:12, 8:7, 5:1> | | |
| PORTG ⁽¹⁾ <15:12, 1:0> | | |

Note 1: Not all of the pins of these PORTS are implemented in 64-pin devices (PIC24FJXXXDAX06); refer to the device pinout diagrams for the details.

PIC24FJ256DA210 FAMILY

[查询PIC24FJ256DA106供应商](#)

REGISTER 10-1: ANSA: PORTA ANALOG FUNCTION SELECTION REGISTER⁽¹⁾

| | | | | | | | |
|--------|-----|-----|-----|-----|--------|-------|-------|
| U-0 | U-0 | U-0 | U-0 | U-0 | R/W-1 | R/W-1 | U-0 |
| — | — | — | — | — | ANSA10 | ANSA9 | — |
| bit 15 | | | | | | | bit 8 |

| | | | | | | | |
|-------|-------|-----|-----|-----|-----|-----|-------|
| R/W-1 | R/W-1 | U-0 | U-0 | U-0 | U-0 | U-0 | U-0 |
| ANSA7 | ANSA6 | — | — | — | — | — | — |
| bit 7 | | | | | | | bit 0 |

Legend:

R = Readable bit W = Writable bit U = Unimplemented bit, read as '0'
 -n = Value at POR '1' = Bit is set '0' = Bit is cleared x = Bit is unknown

- bit 15-11 **Unimplemented:** Read as '0'
- bit 10-9 **ANSA<10:9>:** Analog Function Selection bits
 - 1 = Pin is configured in Analog mode; I/O port read is disabled
 - 0 = Pin is configured in Digital mode; I/O port read is enabled
- bit 8 **Unimplemented:** Read as '0'
- bit 7-6 **ANSA<7:6>:** Analog Function Selection bits
 - 1 = Pin is configured in Analog mode; I/O port read is disabled
 - 0 = Pin is configured in Digital mode; I/O port read is enabled
- bit 5-0 **Unimplemented:** Read as '0'

Note 1: This register is not available on 64-pin devices (PIC24FJXXXDAX06).

PIC24FJ256DA210 FAMILY

[查询PIC24FJ256DA106供应商](#)

REGISTER 10-2: ANSB: PORTB ANALOG FUNCTION SELECTION REGISTER

| | | | | | | | |
|--------|--------|--------|--------|--------|--------|-------|-------|
| R/W-1 | R/W-1 | R/W-1 | R/W-1 | R/W-1 | R/W-1 | R/W-1 | R/W-1 |
| ANSB15 | ANSB14 | ANSB13 | ANSB12 | ANSB11 | ANSB10 | ANSB9 | ANSB8 |
| bit 15 | | | | | | | bit 8 |

| | | | | | | | |
|-------|-------|-------|-------|-------|-------|-------|-------|
| R/W-1 | R/W-1 | R/W-1 | R/W-1 | R/W-1 | R/W-1 | R/W-1 | R/W-1 |
| ANSB7 | ANSB6 | ANSB5 | ANSB4 | ANSB3 | ANSB2 | ANSB1 | ANSB0 |
| bit 7 | | | | | | | bit 0 |

Legend:

R = Readable bit W = Writable bit U = Unimplemented bit, read as '0'
 -n = Value at POR '1' = Bit is set '0' = Bit is cleared x = Bit is unknown

bit 15-0 **ANSB<15:0>**: Analog Function Selection bits
 1 = Pin is configured in Analog mode; I/O port read is disabled
 0 = Pin is configured in Digital mode; I/O port read is enabled

REGISTER 10-3: ANSC: PORTC ANALOG FUNCTION SELECTION REGISTER

| | | | | | | | |
|--------|--------|--------|-----|-----|-----|-----|-------|
| U-0 | R/W-1 | R/W-1 | U-0 | U-0 | U-0 | U-0 | U-0 |
| — | ANSC14 | ANSC13 | — | — | — | — | — |
| bit 15 | | | | | | | bit 8 |

| | | | | | | | |
|-------|-----|-----|----------------------|-----|-----|-----|-------|
| U-0 | U-0 | U-0 | R/W-1 | U-0 | U-0 | U-0 | U-0 |
| — | — | — | ANSC4 ⁽¹⁾ | — | — | — | — |
| bit 7 | | | | | | | bit 0 |

Legend:

R = Readable bit W = Writable bit U = Unimplemented bit, read as '0'
 -n = Value at POR '1' = Bit is set '0' = Bit is cleared x = Bit is unknown

bit 15 **Unimplemented:** Read as '0'
 bit 14-13 **ANSC<14:13>**: Analog Function Selection bits
 1 = Pin is configured in Analog mode; I/O port read is disabled
 0 = Pin is configured in Digital mode; I/O port read is enabled
 bit 12-5 **Unimplemented:** Read as '0'
 bit 4 **ANSC4**: Analog Function Selection bit⁽¹⁾
 1 = Pin is configured in Analog mode; I/O port read is disabled
 0 = Pin is configured in Digital mode; I/O port read is enabled
 bit 3-0 **Unimplemented:** Read as '0'

Note 1: This bit is not available on 64-pin devices (PIC24FJXXXDAX06).

PIC24FJ256DA210 FAMILY

[查询PIC24FJ256DA106供应商](#)

REGISTER 10-4: ANSD: PORTD ANALOG FUNCTION SELECTION REGISTER

| | | | | | | | |
|--------|-----|-----|-----|-----|-----|-----|-------|
| U-0 | U-0 | U-0 | U-0 | U-0 | U-0 | U-0 | U-0 |
| — | — | — | — | — | — | — | — |
| bit 15 | | | | | | | bit 8 |

| | | | | | | | |
|-------|-------|-----|-----|-----|-----|-----|-------|
| R/W-1 | R/W-1 | U-0 | U-0 | U-0 | U-0 | U-0 | U-0 |
| ANSD7 | ANSD6 | — | — | — | — | — | — |
| bit 7 | | | | | | | bit 0 |

Legend:

R = Readable bit W = Writable bit U = Unimplemented bit, read as '0'
 -n = Value at POR '1' = Bit is set '0' = Bit is cleared x = Bit is unknown

bit 15-8 **Unimplemented:** Read as '0'

bit 7-6 **ANSD<7:6>:** Analog Function Selection bits
 1 = Pin is configured in Analog mode; I/O port read is disabled
 0 = Pin is configured in Digital mode; I/O port read is enabled

bit 5-0 **Unimplemented:** Read as '0'

REGISTER 10-5: ANSE: PORTE ANALOG FUNCTION SELECTION REGISTER⁽¹⁾

| | | | | | | | |
|--------|-----|-----|-----|-----|-----|-------|-------|
| U-0 | U-0 | U-0 | U-0 | U-0 | U-0 | R/W-1 | U-0 |
| — | — | — | — | — | — | ANSE9 | — |
| bit 15 | | | | | | | bit 8 |

| | | | | | | | |
|-------|-----|-----|-----|-----|-----|-----|-------|
| U-0 | U-0 | U-0 | U-0 | U-0 | U-0 | U-0 | U-0 |
| — | — | — | — | — | — | — | — |
| bit 7 | | | | | | | bit 0 |

Legend:

R = Readable bit W = Writable bit U = Unimplemented bit, read as '0'
 -n = Value at POR '1' = Bit is set '0' = Bit is cleared x = Bit is unknown

bit 15-10 **Unimplemented:** Read as '0'

bit 9 **ANSE9:** Analog Function Selection bits
 1 = Pin is configured in Analog mode; I/O port read is disabled
 0 = Pin is configured in Digital mode; I/O port read is enabled

bit 8-0 **Unimplemented:** Read as '0'

Note 1: This register is not available in 64-pin devices (PIC24FJXXXDAX06).

PIC24FJ256DA210 FAMILY

[查询PIC24FJ256DA106供应商](#)

REGISTER 10-6: ANSF: PORTF ANALOG FUNCTION SELECTION REGISTER

| | | | | | | | |
|--------|-----|-----|-----|-----|-----|-----|-------|
| U-0 | U-0 | U-0 | U-0 | U-0 | U-0 | U-0 | U-0 |
| — | — | — | — | — | — | — | — |
| bit 15 | | | | | | | bit 8 |

| | | | | | | | |
|-------|-----|-----|-----|-----|-----|-----|-------|
| U-0 | U-0 | U-0 | U-0 | U-0 | U-0 | U-0 | R/W-1 |
| — | — | — | — | — | — | — | ANSF0 |
| bit 7 | | | | | | | bit 0 |

Legend:

R = Readable bit W = Writable bit U = Unimplemented bit, read as '0'
 -n = Value at POR '1' = Bit is set '0' = Bit is cleared x = Bit is unknown

bit 15-1 **Unimplemented:** Read as '0'
 bit 0 **ANSF0:** Analog Function Selection bits
 1 = Pin is configured in Analog mode; I/O port read is disabled
 0 = Pin is configured in Digital mode; I/O port read is enabled

REGISTER 10-7: ANSG: PORTG ANALOG FUNCTION SELECTION REGISTER

| | | | | | | | |
|--------|-----|-----|-----|-----|-----|-------|-------|
| U-0 | U-0 | U-0 | U-0 | U-0 | U-0 | R/W-1 | R/W-1 |
| — | — | — | — | — | — | ANSG9 | ANSG8 |
| bit 15 | | | | | | | bit 8 |

| | | | | | | | |
|-------|-------|-----|-----|-----|-----|-----|-------|
| R/W-1 | R/W-1 | U-0 | U-0 | U-0 | U-0 | U-0 | U-0 |
| ANSG7 | ANSG6 | — | — | — | — | — | — |
| bit 7 | | | | | | | bit 0 |

Legend:

R = Readable bit W = Writable bit U = Unimplemented bit, read as '0'
 -n = Value at POR '1' = Bit is set '0' = Bit is cleared x = Bit is unknown

bit 15-10 **Unimplemented:** Read as '0'
 bit 9-6 **ANSG<9:6>:** Analog Function Selection bits
 1 = Pin is configured in Analog mode; I/O port read is disabled
 0 = Pin is configured in Digital mode; I/O port read is enabled
 bit 5-0 **Unimplemented:** Read as '0'

PIC24FJ256DA210 FAMILY

[查询PIC24FJ256DA106供应商](#)

10.3 Input Change Notification

The input change notification function of the I/O ports allows the PIC24FJ256DA210 family of devices to generate interrupt requests to the processor in response to a Change-Of-State (COS) on selected input pins. This feature is capable of detecting input Change-Of-States, even in Sleep mode, when the clocks are disabled. Depending on the device pin count, there are up to 84 external inputs that may be selected (enabled) for generating an interrupt request on a Change-Of-State.

Registers, CNEN1 through CNEN6, contain the interrupt enable control bits for each of the CN input pins. Setting any of these bits enables a CN interrupt for the corresponding pins.

Each CN pin has a both a weak pull-up and a weak pull-down connected to it. The pull-ups act as a current source that is connected to the pin, while the pull-downs act as a current sink that is connected to the pin. These eliminate the need for external resistors

when push button or keypad devices are connected. The pull-ups and pull-downs are separately enabled using the CNPU1 through CNPU6 registers (for pull-ups), and the CNPD1 through CNPD6 registers (for pull-downs). Each CN pin has individual control bits for its pull-up and pull-down. Setting a control bit enables the weak pull-up or pull-down for the corresponding pin.

When the internal pull-up is selected, the pin pulls up to $V_{DD} - 1.1V$ (typical). When the internal pull-down is selected, the pin pulls down to V_{SS} .

Note: Pull-ups on change notification pins should always be disabled whenever the port pin is configured as a digital output.

Note: To use CN83 and CN84, which are on the D+ and D- pins, the UTRDIS bit (U1CNFG2<0>) should be set.

EXAMPLE 10-1: PORT WRITE/READ IN ASSEMBLY

```
MOV    0xFF00, W0    ; Configure PORTB<15:8> as inputs
MOV    W0, TRISB    ; and PORTB<7:0> as outputs
NOP                                ; Delay 1 cycle
BTSS   PORTB, #13   ; Next Instruction
```

EXAMPLE 10-2: PORT WRITE/READ IN 'C'

```
TRISB = 0xFF00;           // Configure PORTB<15:8> as inputs and PORTB<7:0> as outputs
Nop();                    // Delay 1 cycle
If (PORTBbits.RB13){ };   // Next Instruction
```

PIC24FJ256DA210 FAMILY

[查询PIC24FJ256DA106供应商](#)

10.4 Peripheral Pin Select (PPS)

A major challenge in general purpose devices is providing the largest possible set of peripheral features while minimizing the conflict of features on I/O pins. In an application that needs to use more than one peripheral multiplexed on a single pin, inconvenient work arounds in application code or a complete redesign may be the only option.

The Peripheral Pin Select (PPS) feature provides an alternative to these choices by enabling the user's peripheral set selection and its placement on a wide range of I/O pins. By increasing the pinout options available on a particular device, users can better tailor the microcontroller to their entire application, rather than trimming the application to fit the device.

The Peripheral Pin Select feature operates over a fixed subset of digital I/O pins. Users may independently map the input and/or output of any one of many digital peripherals to any one of these I/O pins. PPS is performed in software and generally does not require the device to be reprogrammed. Hardware safeguards are included that prevent accidental or spurious changes to the peripheral mapping once it has been established.

10.4.1 AVAILABLE PINS

The PPS feature is used with a range of up to 44 pins, depending on the particular device and its pin count. Pins that support the Peripheral Pin Select feature include the designation, "RPn" or "RPI n", in their full pin designation, where "n" is the remappable pin number. "RP" is used to designate pins that support both remappable input and output functions, while "RPI" indicates pins that support remappable input functions only.

PIC24FJ256DA210 family devices support a larger number of remappable input only pins than remappable input/output pins. In this device family, there are up to 32 remappable input/output pins, depending on the pin count of the particular device selected; these are numbered, RP0 through RP31. Remappable input only pins are numbered above this range, from RPI32 to RPI43 (or the upper limit for that particular device).

See Table 1-1 for a summary of pinout options in each package offering.

10.4.2 AVAILABLE PERIPHERALS

The peripherals managed by the PPS are all digital only peripherals. These include general serial communications (UART and SPI), general purpose timer clock inputs, timer related peripherals (input capture and output compare) and external interrupt inputs. Also included are the outputs of the comparator module, since these are discrete digital signals.

PPS is not available for I²C™, change notification inputs, RTCC alarm outputs, EPMP signals, graphics controller signals or peripherals with analog inputs.

A key difference between pin select and non-pin select peripherals is that pin select peripherals are not associated with a default I/O pin. The peripheral must always be assigned to a specific I/O pin before it can be used. In contrast, non pin select peripherals are always available on a default pin, assuming that the peripheral is active and not conflicting with another peripheral.

10.4.2.1 Peripheral Pin Select Function Priority

Pin-selectable peripheral outputs (e.g., OC, UART transmit) will take priority over general purpose digital functions on a pin, such as EPMP and port I/O. Specialized digital outputs, such as USB functionality, will take priority over PPS outputs on the same pin. The pin diagrams list peripheral outputs in the order of priority. Refer to them for priority concerns on a particular pin.

Unlike PIC24F devices with fixed peripherals, pin selectable peripheral inputs will never take ownership of a pin. The pin's output buffer will be controlled by the TRISx setting or by a fixed peripheral on the pin. If the pin is configured in digital mode then the PPS input will operate correctly. If an analog function is enabled on the pin the PPS input will be disabled.

10.4.3 CONTROLLING PERIPHERAL PIN SELECT

PPS features are controlled through two sets of Special Function Registers (SFRs): one to map peripheral inputs and one to map outputs. Because they are separately controlled, a particular peripheral's input and output (if the peripheral has both) can be placed on any selectable function pin without constraint.

The association of a peripheral to a peripheral-selectable pin is handled in two different ways, depending on if an input or an output is being mapped.

10.4.3.1 Input Mapping

The inputs of the Peripheral Pin Select options are mapped on the basis of the peripheral; that is, a control register associated with a peripheral dictates the pin it will be mapped to. The RPI n registers are used to configure peripheral input mapping (see Register 10-8 through Register 10-28). Each register contains two sets of 6-bit fields, with each set associated with one of the pin-selectable peripherals. Programming a given peripheral's bit field with an appropriate 6-bit value maps the RPn/RPI n pin with that value to that peripheral. For any given device, the valid range of values for any of the bit fields corresponds to the maximum number of Peripheral Pin Selections supported by the device.

PIC24FJ256DA210 FAMILY

[查询PIC24FJ256DA106供应商](#)

TABLE 10-3: SELECTABLE INPUT SOURCES (MAPS INPUT TO FUNCTION)⁽¹⁾

| Input Name | Function Name | Register | Function Mapping Bits |
|-------------------------|--------------------|----------|-----------------------|
| External Interrupt 1 | INT1 | RPINR0 | INT1R<5:0> |
| External Interrupt 2 | INT2 | RPINR1 | INT2R<5:0> |
| External Interrupt 3 | INT3 | RPINR1 | INT3R<5:0> |
| External Interrupt 4 | INT4 | RPINR2 | INT4R<5:0> |
| Input Capture 1 | IC1 | RPINR7 | IC1R<5:0> |
| Input Capture 2 | IC2 | RPINR7 | IC2R<5:0> |
| Input Capture 3 | IC3 | RPINR8 | IC3R<5:0> |
| Input Capture 4 | IC4 | RPINR8 | IC4R<5:0> |
| Input Capture 5 | IC5 | RPINR9 | IC5R<5:0> |
| Input Capture 6 | IC6 | RPINR9 | IC6R<5:0> |
| Input Capture 7 | IC7 | RPINR10 | IC7R<5:0> |
| Input Capture 8 | IC8 | RPINR10 | IC8R<5:0> |
| Input Capture 9 | IC9 | RPINR15 | IC9R<5:0> |
| Output Compare Fault A | OCFA | RPINR11 | OCFAR<5:0> |
| Output Compare Fault B | OCFB | RPINR11 | OCFBR<5:0> |
| SPI1 Clock Input | SCK1IN | RPINR20 | SCK1R<5:0> |
| SPI1 Data Input | SDI1 | RPINR20 | SDI1R<5:0> |
| SPI1 Slave Select Input | SS1IN | RPINR21 | SS1R<5:0> |
| SPI2 Clock Input | SCK2IN | RPINR22 | SCK2R<5:0> |
| SPI2 Data Input | SDI2 | RPINR22 | SDI2R<5:0> |
| SPI2 Slave Select Input | SS2IN | RPINR23 | SS2R<5:0> |
| SPI3 Clock Input | SCK3IN | RPINR28 | SCK3R<5:0> |
| SPI3 Data Input | SDI3 | RPINR28 | SDI3R<5:0> |
| SPI3 Slave Select Input | SS3IN | RPINR29 | SS3R<5:0> |
| Timer2 External Clock | T2CK | RPINR3 | T2CKR<5:0> |
| Timer3 External Clock | T3CK | RPINR3 | T3CKR<5:0> |
| Timer4 External Clock | T4CK | RPINR4 | T4CKR<5:0> |
| Timer5 External Clock | T5CK | RPINR4 | T5CKR<5:0> |
| UART1 Clear To Send | $\overline{U1CTS}$ | RPINR18 | U1CTSR<5:0> |
| UART1 Receive | U1RX | RPINR18 | U1RXR<5:0> |
| UART2 Clear To Send | $\overline{U2CTS}$ | RPINR19 | U2CTSR<5:0> |
| UART2 Receive | U2RX | RPINR19 | U2RXR<5:0> |
| UART3 Clear To Send | $\overline{U3CTS}$ | RPINR21 | U3CTSR<5:0> |
| UART3 Receive | U3RX | RPINR17 | U3RXR<5:0> |
| UART4 Clear To Send | $\overline{U4CTS}$ | RPINR27 | U4CTSR<5:0> |
| UART4 Receive | U4RX | RPINR27 | U4RXR<5:0> |

Note 1: Unless otherwise noted, all inputs use the Schmitt Trigger (ST) input buffers.

PIC24FJ256DA210 FAMILY

[查询PIC24FJ256DA106供应商](#)

10.4.3.2 Output Mapping

In contrast to inputs, the outputs of the Peripheral Pin Select options are mapped on the basis of the pin. In this case, a control register associated with a particular pin dictates the peripheral output to be mapped. The RPORx registers are used to control output mapping. Each register contains two 6-bit fields, with each field being associated with one RPN pin (see Register 10-29 through Register 10-44). The value of the bit field

corresponds to one of the peripherals and that peripheral's output is mapped to the pin (see Table 10-4).

Because of the mapping technique, the list of peripherals for output mapping also includes a null value of '000000'. This permits any given pin to remain disconnected from the output of any of the pin-selectable peripherals.

TABLE 10-4: SELECTABLE OUTPUT SOURCES (MAPS FUNCTION TO OUTPUT)

| Output Function Number ⁽¹⁾ | Function | Output Name |
|---------------------------------------|--------------------------|--------------------------|
| 0 | NULL ⁽²⁾ | Null |
| 1 | C1OUT | Comparator 1 Output |
| 2 | C2OUT | Comparator 2 Output |
| 3 | U1TX | UART1 Transmit |
| 4 | $\overline{U1RTS}^{(3)}$ | UART1 Request To Send |
| 5 | U2TX | UART2 Transmit |
| 6 | $\overline{U2RTS}^{(3)}$ | UART2 Request To Send |
| 7 | SDO1 | SPI1 Data Output |
| 8 | SCK1OUT | SPI1 Clock Output |
| 9 | SS1OUT | SPI1 Slave Select Output |
| 10 | SDO2 | SPI2 Data Output |
| 11 | SCK2OUT | SPI2 Clock Output |
| 12 | SS2OUT | SPI2 Slave Select Output |
| 18 | OC1 | Output Compare 1 |
| 19 | OC2 | Output Compare 2 |
| 20 | OC3 | Output Compare 3 |
| 21 | OC4 | Output Compare 4 |
| 22 | OC5 | Output Compare 5 |
| 23 | OC6 | Output Compare 6 |
| 24 | OC7 | Output Compare 7 |
| 25 | OC8 | Output Compare 8 |
| 28 | U3TX | UART3 Transmit |
| 29 | $\overline{U3RTS}^{(3)}$ | UART3 Request To Send |
| 30 | U4TX | UART4 Transmit |
| 31 | $\overline{U4RTS}^{(3)}$ | UART4 Request To Send |
| 32 | SDO3 | SPI3 Data Output |
| 33 | SCK3OUT | SPI3 Clock Output |
| 34 | SS3OUT | SPI3 Slave Select Output |
| 35 | OC9 | Output Compare 9 |
| 36 | C3OUT | Comparator 3 Output |
| 37-63 | (unused) | NC |

- Note 1:** Setting the RPORx register with the listed value assigns that output function to the associated RPN pin.
Note 2: The NULL function is assigned to all RPN outputs at device Reset and disables the RPN output function.
Note 3: IrDA[®] BCLK functionality uses this output.

PIC24FJ256DA210 FAMILY

[查询PIC24FJ256DA106供应商](#)

10.4.3.3 Mapping Limitations

The control schema of the Peripheral Pin Select is extremely flexible. Other than systematic blocks that prevent signal contention, caused by two physical pins being configured as the same functional input or two functional outputs configured as the same pin, there are no hardware enforced lock outs. The flexibility extends to the point of allowing a single input to drive multiple peripherals or a single functional output to drive multiple output pins.

10.4.3.4 Mapping Exceptions for PIC24FJ256DA210 Devices

Although the PPS registers theoretically allow for up to 64 remappable I/O pins, not all of these are implemented in all devices. For PIC24FJ256DA210 family devices, the maximum number of remappable pins available are 44, which includes 12 input only pins. In addition, some pins in the RP and RPI sequences are unimplemented in lower pin count devices. The differences in available remappable pins are summarized in Table 10-5.

When developing applications that use remappable pins, users should also keep these things in mind:

- For the RPINRx registers, bit combinations corresponding to an unimplemented pin for a particular device are treated as invalid; the corresponding module will not have an input mapped to it. For all PIC24FJ256DA210 family devices, this includes all values greater than 43 ('101011').
- For RPORx registers, the bit fields corresponding to an unimplemented pin will also be unimplemented. Writing to these fields will have no effect.

10.4.4 CONTROLLING CONFIGURATION CHANGES

Because peripheral remapping can be changed during run time, some restrictions on peripheral remapping are needed to prevent accidental configuration changes. PIC24F devices include three features to prevent alterations to the peripheral map:

- Control register lock sequence
- Continuous state monitoring
- Configuration bit remapping lock

10.4.4.1 Control Register Lock

Under normal operation, writes to the RPINRx and RPORx registers are not allowed. Attempted writes will appear to execute normally, but the contents of the registers will remain unchanged. To change these registers, they must be unlocked in hardware. The register lock is controlled by the IOLOCK bit (OSCCON<6>). Setting IOLOCK prevents writes to the control registers; clearing IOLOCK allows writes.

To set or clear IOLOCK, a specific command sequence must be executed:

1. Write 46h to OSCCON<7:0>.
2. Write 57h to OSCCON<7:0>.
3. Clear (or set) IOLOCK as a single operation.

Unlike the similar sequence with the oscillator's LOCK bit, IOLOCK remains in one state until changed. This allows all of the Peripheral Pin Selects to be configured with a single unlock sequence, followed by an update to all control registers, then locked with a second lock sequence.

10.4.4.2 Continuous State Monitoring

In addition to being protected from direct writes, the contents of the RPINRx and RPORx registers are constantly monitored in hardware by shadow registers. If an unexpected change in any of the registers occurs (such as cell disturbances caused by ESD or other external events), a Configuration Mismatch Reset will be triggered.

10.4.4.3 Configuration Bit Pin Select Lock

As an additional level of safety, the device can be configured to prevent more than one write session to the RPINRx and RPORx registers. The IOL1WAY (CW2<4>) Configuration bit blocks the IOLOCK bit from being cleared after it has been set once. If IOLOCK remains set, the register unlock procedure will not execute and the Peripheral Pin Select Control registers cannot be written to. The only way to clear the bit and re-enable peripheral remapping is to perform a device Reset.

In the default (unprogrammed) state, IOL1WAY is set, restricting users to one write session. Programming IOL1WAY allows users unlimited access (with the proper use of the unlock sequence) to the Peripheral Pin Select registers.

TABLE 10-5: REMAPPABLE PIN EXCEPTIONS FOR PIC24FJ256DA210 FAMILY DEVICES

| Device Pin Count | RP Pins (I/O) | | RPI Pins | |
|---------------------------------|---------------|-----------------------|----------|--------------------|
| | Total | Unimplemented | Total | Unimplemented |
| 64-Pin (PIC24FJXXDAX06) | 28 | RP5, RP15, RP30, RP31 | 1 | RPI32-36, RPI38-43 |
| 100/121-Pin (PIC24FJXXDAX10) | 32 | — | 12 | — |

PIC24FJ256DA210 FAMILY

[查询PIC24FJ256DA106供应商](#)

10.4.5 CONSIDERATIONS FOR PERIPHERAL PIN SELECTION

The ability to control Peripheral Pin Selection introduces several considerations into application design that could be overlooked. This is particularly true for several common peripherals that are available only as remappable peripherals.

The main consideration is that the Peripheral Pin Selects are not available on default pins in the device's default (Reset) state. Since all RPINRx registers reset to '111111' and all RPORx registers reset to '000000', all Peripheral Pin Select inputs are tied to Vss and all Peripheral Pin Select outputs are disconnected.

Note: In tying Peripheral Pin Select inputs to RP63, RP63 need not exist on a device for the registers to be reset to it.

This situation requires the user to initialize the device with the proper peripheral configuration before any other application code is executed. Since the IOLOCK bit resets in the unlocked state, it is not necessary to execute the unlock sequence after the device has come out of Reset. For application safety, however, it is best to set IOLOCK and lock the configuration after writing to the control registers.

Because the unlock sequence is timing-critical, it must be executed as an assembly language routine in the same manner as changes to the oscillator configuration. If the bulk of the application is written in 'C', or another high-level language, the unlock sequence should be performed by writing in-line assembly.

Choosing the configuration requires the review of all Peripheral Pin Selects and their pin assignments, especially those that will not be used in the application. In all cases, unused pin-selectable peripherals should be disabled completely. Unused peripherals should have their inputs assigned to an unused RPn/RPn pin function. I/O pins with unused RPn functions should be configured with the null peripheral output.

The assignment of a peripheral to a particular pin does not automatically perform any other configuration of the pin's I/O circuitry. In theory, this means adding a pin-selectable output to a pin may mean inadvertently driving an existing peripheral input when the output is driven. Users must be familiar with the behavior of other fixed peripherals that share a remappable pin and know when to enable or disable them. To be safe, fixed digital peripherals that share the same pin should be disabled when not in use.

Along these lines, configuring a remappable pin for a specific peripheral does not automatically turn that feature on. The peripheral must be specifically configured for operation, and enabled as if it were tied to a fixed pin. Where this happens in the application code (immediately following device Reset and peripheral configuration or inside the main application routine) depends on the peripheral and its use in the application.

A final consideration is that Peripheral Pin Select functions neither override analog inputs nor reconfigure pins with analog functions for digital I/O. If a pin is configured as an analog input on device Reset, it must be explicitly reconfigured as digital I/O when used with a Peripheral Pin Select.

Example 10-3 shows a configuration for bidirectional communication with flow control using UART1. The following input and output functions are used:

- Input Functions: U1RX, U1CTS
- Output Functions: U1TX, U1RTS

EXAMPLE 10-3: CONFIGURING UART1 INPUT AND OUTPUT FUNCTIONS

```
// Unlock Registers
asm volatile( "MOV    #OSCCON, w1  \n"
             "MOV    #0x46, w2    \n"
             "MOV    #0x57, w3    \n"
             "MOV.b  w2, [w1]     \n"
             "MOV.b  w3, [w1]     \n"
             "BCLR  OSCCON,#6" );

// or use C30 built-in macro:
// __builtin_write_OSCCONL(OSCCON & 0xbf);

// Configure Input Functions (Table 10-2))
// Assign U1RX To Pin RP0
RPINR18bits.U1RXR = 0;

// Assign U1CTS To Pin RP1
RPINR18bits.U1CTSR = 1;

// Configure Output Functions (Table 10-4)
// Assign U1TX To Pin RP2
RPOR1bits.RP2R = 3;

// Assign U1RTS To Pin RP3
RPOR1bits.RP3R = 4;

// Lock Registers
asm volatile ("MOV    #OSCCON, w1  \n"
             "MOV    #0x46, w2    \n"
             "MOV    #0x57, w3    \n"
             "MOV.b  w2, [w1]\n"
             "MOV.b  w3, [w1] \n"
             "BSET  OSCCON, #6" );

// or use C30 built-in macro:
// __builtin_write_OSCCONL(OSCCON | 0x40);
```

PIC24FJ256DA210 FAMILY

[查询PIC24FJ256DA106供应商](#)

10.4.6 PERIPHERAL PIN SELECT REGISTERS

The PIC24FJ256DA210 family of devices implements a total of 37 registers for remappable peripheral configuration:

- Input Remappable Peripheral Registers (21)
- Output Remappable Peripheral Registers (16)

Note: Input and output register values can only be changed if IOLOCK (OSCCON<6>) = 0. See **Section 10.4.4.1 “Control Register Lock”** for a specific command sequence.

REGISTER 10-8: RPINR0: PERIPHERAL PIN SELECT INPUT REGISTER 0

| | | | | | | | |
|--------|-----|--------|--------|--------|--------|--------|--------|
| U-0 | U-0 | R/W-1 | R/W-1 | R/W-1 | R/W-1 | R/W-1 | R/W-1 |
| — | — | INT1R5 | INT1R4 | INT1R3 | INT1R2 | INT1R1 | INT1R0 |
| bit 15 | | | | | | | bit 8 |

| | | | | | | | |
|-------|-----|-----|-----|-----|-----|-----|-------|
| U-0 | U-0 | U-0 | U-0 | U-0 | U-0 | U-0 | U-0 |
| — | — | — | — | — | — | — | — |
| bit 7 | | | | | | | bit 0 |

Legend:

R = Readable bit W = Writable bit U = Unimplemented bit, read as '0'
 -n = Value at POR '1' = Bit is set '0' = Bit is cleared x = Bit is unknown

bit 15-14 **Unimplemented:** Read as '0'

bit 13-8 **INT1R<5:0>:** Assign External Interrupt 1 (INT1) to Corresponding RPn or RPIn Pin bits

bit 7-0 **Unimplemented:** Read as '0'

REGISTER 10-9: RPINR1: PERIPHERAL PIN SELECT INPUT REGISTER 1

| | | | | | | | |
|--------|-----|--------|--------|--------|--------|--------|--------|
| U-0 | U-0 | R/W-1 | R/W-1 | R/W-1 | R/W-1 | R/W-1 | R/W-1 |
| — | — | INT3R5 | INT3R4 | INT3R3 | INT3R2 | INT3R1 | INT3R0 |
| bit 15 | | | | | | | bit 8 |

| | | | | | | | |
|-------|-----|--------|--------|--------|--------|--------|--------|
| U-0 | U-0 | R/W-1 | R/W-1 | R/W-1 | R/W-1 | R/W-1 | R/W-1 |
| — | — | INT2R5 | INT2R4 | INT2R3 | INT2R2 | INT2R1 | INT2R0 |
| bit 7 | | | | | | | bit 0 |

Legend:

R = Readable bit W = Writable bit U = Unimplemented bit, read as '0'
 -n = Value at POR '1' = Bit is set '0' = Bit is cleared x = Bit is unknown

bit 15-14 **Unimplemented:** Read as '0'

bit 13-8 **INT3R<5:0>:** Assign External Interrupt 3 (INT3) to Corresponding RPn or RPIn Pin bits

bit 7-6 **Unimplemented:** Read as '0'

bit 5-0 **INT2R<5:0>:** Assign External Interrupt 2 (INT2) to Corresponding RPn or RPIn Pin bits

PIC24FJ256DA210 FAMILY

[查询PIC24FJ256DA106供应商](#)

REGISTER 10-10: RPINR2: PERIPHERAL PIN SELECT INPUT REGISTER 2

| | | | | | | | |
|--------|-----|-----|-----|-----|-----|-----|-------|
| U-0 | U-0 | U-0 | U-0 | U-0 | U-0 | U-0 | U-0 |
| — | — | — | — | — | — | — | — |
| bit 15 | | | | | | | bit 8 |

| | | | | | | | |
|-------|-----|--------|--------|--------|--------|--------|--------|
| U-0 | U-0 | R/W-1 | R/W-1 | R/W-1 | R/W-1 | R/W-1 | R/W-1 |
| — | — | INT4R5 | INT4R4 | INT4R3 | INT4R2 | INT4R1 | INT4R0 |
| bit 7 | | | | | | | bit 0 |

Legend:

R = Readable bit

W = Writable bit

U = Unimplemented bit, read as '0'

-n = Value at POR

'1' = Bit is set

'0' = Bit is cleared

x = Bit is unknown

bit 15-6 **Unimplemented:** Read as '0'

bit 5-0 **INT4R<5:0>:** Assign External Interrupt 4 (INT4) to Corresponding RPN or RPN Pin bits

REGISTER 10-11: RPINR3: PERIPHERAL PIN SELECT INPUT REGISTER 3

| | | | | | | | |
|--------|-----|--------|--------|--------|--------|--------|--------|
| U-0 | U-0 | R/W-1 | R/W-1 | R/W-1 | R/W-1 | R/W-1 | R/W-1 |
| — | — | T3CKR5 | T3CKR4 | T3CKR3 | T3CKR2 | T3CKR1 | T3CKR0 |
| bit 15 | | | | | | | bit 8 |

| | | | | | | | |
|-------|-----|--------|--------|--------|--------|--------|--------|
| U-0 | U-0 | R/W-1 | R/W-1 | R/W-1 | R/W-1 | R/W-1 | R/W-1 |
| — | — | T2CKR5 | T2CKR4 | T2CKR3 | T2CKR2 | T2CKR1 | T2CKR0 |
| bit 7 | | | | | | | bit 0 |

Legend:

R = Readable bit

W = Writable bit

U = Unimplemented bit, read as '0'

-n = Value at POR

'1' = Bit is set

'0' = Bit is cleared

x = Bit is unknown

bit 15-14 **Unimplemented:** Read as '0'

bit 13-8 **T3CKR<5:0>:** Assign Timer3 External Clock (T3CK) to Corresponding RPN or RPN Pin bits

bit 7-6 **Unimplemented:** Read as '0'

bit 5-0 **T2CKR<5:0>:** Assign Timer2 External Clock (T2CK) to Corresponding RPN or RPN Pin bits

PIC24FJ256DA210 FAMILY

[查询PIC24FJ256DA106供应商](#)

REGISTER 10-12: RPINR4: PERIPHERAL PIN SELECT INPUT REGISTER 4

| | | | | | | | |
|--------|-----|--------|--------|--------|--------|--------|--------|
| U-0 | U-0 | R/W-1 | R/W-1 | R/W-1 | R/W-1 | R/W-1 | R/W-1 |
| — | — | T5CKR5 | T5CKR4 | T5CKR3 | T5CKR2 | T5CKR1 | T5CKR0 |
| bit 15 | | | | | | | bit 8 |

| | | | | | | | |
|-------|-----|--------|--------|--------|--------|--------|--------|
| U-0 | U-0 | R/W-1 | R/W-1 | R/W-1 | R/W-1 | R/W-1 | R/W-1 |
| — | — | T4CKR5 | T4CKR4 | T4CKR3 | T4CKR2 | T4CKR1 | T4CKR0 |
| bit 7 | | | | | | | bit 0 |

Legend:

R = Readable bit W = Writable bit U = Unimplemented bit, read as '0'
 -n = Value at POR '1' = Bit is set '0' = Bit is cleared x = Bit is unknown

- bit 15-14 **Unimplemented:** Read as '0'
- bit 13-8 **T5CKR<5:0>:** Assign Timer5 External Clock (T5CK) to Corresponding RPn or RPIIn Pin bits
- bit 7-6 **Unimplemented:** Read as '0'
- bit 5-0 **T4CKR<5:0>:** Assign Timer4 External Clock (T4CK) to Corresponding RPn or RPIIn Pin bits

REGISTER 10-13: RPINR7: PERIPHERAL PIN SELECT INPUT REGISTER 7

| | | | | | | | |
|--------|-----|-------|-------|-------|-------|-------|-------|
| U-0 | U-0 | R/W-1 | R/W-1 | R/W-1 | R/W-1 | R/W-1 | R/W-1 |
| — | — | IC2R5 | IC2R4 | IC2R3 | IC2R2 | IC2R1 | IC2R0 |
| bit 15 | | | | | | | bit 8 |

| | | | | | | | |
|-------|-----|-------|-------|-------|-------|-------|-------|
| U-0 | U-0 | R/W-1 | R/W-1 | R/W-1 | R/W-1 | R/W-1 | R/W-1 |
| — | — | IC1R5 | IC1R4 | IC1R3 | IC1R2 | IC1R1 | IC1R0 |
| bit 7 | | | | | | | bit 0 |

Legend:

R = Readable bit W = Writable bit U = Unimplemented bit, read as '0'
 -n = Value at POR '1' = Bit is set '0' = Bit is cleared x = Bit is unknown

- bit 15-14 **Unimplemented:** Read as '0'
- bit 13-8 **IC2R<5:0>:** Assign Input Capture 2 (IC2) to Corresponding RPn or RPIIn Pin bits
- bit 7-6 **Unimplemented:** Read as '0'
- bit 5-0 **IC1R<5:0>:** Assign Input Capture 1 (IC1) to Corresponding RPn or RPIIn Pin bits

PIC24FJ256DA210 FAMILY

[查询PIC24FJ256DA106供应商](#)

REGISTER 10-14: RPINR8: PERIPHERAL PIN SELECT INPUT REGISTER 8

| | | | | | | | |
|--------|-----|-------|-------|-------|-------|-------|-------|
| U-0 | U-0 | R/W-1 | R/W-1 | R/W-1 | R/W-1 | R/W-1 | R/W-1 |
| — | — | IC4R5 | IC4R4 | IC4R3 | IC4R2 | IC4R1 | IC4R0 |
| bit 15 | | | | | | | bit 8 |

| | | | | | | | |
|-------|-----|-------|-------|-------|-------|-------|-------|
| U-0 | U-0 | R/W-1 | R/W-1 | R/W-1 | R/W-1 | R/W-1 | R/W-1 |
| — | — | IC3R5 | IC3R4 | IC3R3 | IC3R2 | IC3R1 | IC3R0 |
| bit 7 | | | | | | | bit 0 |

Legend:

R = Readable bit W = Writable bit U = Unimplemented bit, read as '0'
 -n = Value at POR '1' = Bit is set '0' = Bit is cleared x = Bit is unknown

- bit 15-14 **Unimplemented:** Read as '0'
- bit 13-8 **IC4R<5:0>:** Assign Input Capture 4 (IC4) to Corresponding RPn or RPIn Pin bits
- bit 7-6 **Unimplemented:** Read as '0'
- bit 5-0 **IC3R<5:0>:** Assign Input Capture 3 (IC3) to Corresponding RPn or RPIn Pin bits

REGISTER 10-15: RPINR9: PERIPHERAL PIN SELECT INPUT REGISTER 9

| | | | | | | | |
|--------|-----|-------|-------|-------|-------|-------|-------|
| U-0 | U-0 | R/W-1 | R/W-1 | R/W-1 | R/W-1 | R/W-1 | R/W-1 |
| — | — | IC6R5 | IC6R4 | IC6R3 | IC6R2 | IC6R1 | IC6R0 |
| bit 15 | | | | | | | bit 8 |

| | | | | | | | |
|-------|-----|-------|-------|-------|-------|-------|-------|
| U-0 | U-0 | R/W-1 | R/W-1 | R/W-1 | R/W-1 | R/W-1 | R/W-1 |
| — | — | IC5R5 | IC5R4 | IC5R3 | IC5R2 | IC5R1 | IC5R0 |
| bit 7 | | | | | | | bit 0 |

Legend:

R = Readable bit W = Writable bit U = Unimplemented bit, read as '0'
 -n = Value at POR '1' = Bit is set '0' = Bit is cleared x = Bit is unknown

- bit 15-14 **Unimplemented:** Read as '0'
- bit 13-8 **IC6R<5:0>:** Assign Input Capture 6 (IC6) to Corresponding RPn or RPIn Pin bits
- bit 7-6 **Unimplemented:** Read as '0'
- bit 5-0 **IC5R<5:0>:** Assign Input Capture 5 (IC5) to Corresponding RPn or RPIn Pin bits

PIC24FJ256DA210 FAMILY

[查询PIC24FJ256DA106供应商](#)

REGISTER 10-16: RPINR10: PERIPHERAL PIN SELECT INPUT REGISTER 10

| | | | | | | | |
|--------|-----|-------|-------|-------|-------|-------|-------|
| U-0 | U-0 | R/W-1 | R/W-1 | R/W-1 | R/W-1 | R/W-1 | R/W-1 |
| — | — | IC8R5 | IC8R4 | IC8R3 | IC8R2 | IC8R1 | IC8R0 |
| bit 15 | | | | | | | bit 8 |

| | | | | | | | |
|-------|-----|-------|-------|-------|-------|-------|-------|
| U-0 | U-0 | R/W-1 | R/W-1 | R/W-1 | R/W-1 | R/W-1 | R/W-1 |
| — | — | IC7R5 | IC7R4 | IC7R3 | IC7R2 | IC7R1 | IC7R0 |
| bit 7 | | | | | | | bit 0 |

Legend:

R = Readable bit W = Writable bit U = Unimplemented bit, read as '0'
 -n = Value at POR '1' = Bit is set '0' = Bit is cleared x = Bit is unknown

- bit 15-14 **Unimplemented:** Read as '0'
- bit 13-8 **IC8R<5:0>:** Assign Input Capture 8 (IC8) to Corresponding RPn or RPIIn Pin bits
- bit 7-6 **Unimplemented:** Read as '0'
- bit 5-0 **IC7R<5:0>:** Assign Input Capture 7 (IC7) to Corresponding RPn or RPIIn Pin bits

REGISTER 10-17: RPINR11: PERIPHERAL PIN SELECT INPUT REGISTER 11

| | | | | | | | |
|--------|-----|--------|--------|--------|--------|--------|--------|
| U-0 | U-0 | R/W-1 | R/W-1 | R/W-1 | R/W-1 | R/W-1 | R/W-1 |
| — | — | OCFBR5 | OCFBR4 | OCFBR3 | OCFBR2 | OCFBR1 | OCFBR0 |
| bit 15 | | | | | | | bit 8 |

| | | | | | | | |
|-------|-----|--------|--------|--------|--------|--------|--------|
| U-0 | U-0 | R/W-1 | R/W-1 | R/W-1 | R/W-1 | R/W-1 | R/W-1 |
| — | — | OCFAR5 | OCFAR4 | OCFAR3 | OCFAR2 | OCFAR1 | OCFAR0 |
| bit 7 | | | | | | | bit 0 |

Legend:

R = Readable bit W = Writable bit U = Unimplemented bit, read as '0'
 -n = Value at POR '1' = Bit is set '0' = Bit is cleared x = Bit is unknown

- bit 15-14 **Unimplemented:** Read as '0'
- bit 13-8 **OCFBR<5:0>:** Assign Output Compare Fault B (OCFB) to Corresponding RPn or RPIIn Pin bits
- bit 7-6 **Unimplemented:** Read as '0'
- bit 5-0 **OCFAR<5:0>:** Assign Output Compare Fault A (OCFA) to Corresponding RPn or RPIIn Pin bits

PIC24FJ256DA210 FAMILY

[查询PIC24FJ256DA106供应商](#)

REGISTER 10-18: RPINR15: PERIPHERAL PIN SELECT INPUT REGISTER 15

| | | | | | | | |
|--------|-----|-------|-------|-------|-------|-------|-------|
| U-0 | U-0 | R/W-1 | R/W-1 | R/W-1 | R/W-1 | R/W-1 | R/W-1 |
| — | — | IC9R5 | IC9R4 | IC9R3 | IC9R2 | IC9R1 | IC9R0 |
| bit 15 | | | | | | | bit 8 |

| | | | | | | | |
|-------|-----|-----|-----|-----|-----|-----|-------|
| U-0 | U-0 | U-0 | U-0 | U-0 | U-0 | U-0 | U-0 |
| — | — | — | — | — | — | — | — |
| bit 7 | | | | | | | bit 0 |

Legend:

R = Readable bit W = Writable bit U = Unimplemented bit, read as '0'
 -n = Value at POR '1' = Bit is set '0' = Bit is cleared x = Bit is unknown

bit 15-14 **Unimplemented:** Read as '0'
 bit 13-8 **IC9R<5:0>:** Assign Input Capture 9 (IC9) to Corresponding RPn or RPIn Pin bits
 bit 7-0 **Unimplemented:** Read as '0'

REGISTER 10-19: RPINR17: PERIPHERAL PIN SELECT INPUT REGISTER 17

| | | | | | | | |
|--------|-----|--------|--------|--------|--------|--------|--------|
| U-0 | U-0 | R/W-1 | R/W-1 | R/W-1 | R/W-1 | R/W-1 | R/W-1 |
| — | — | U3RXR5 | U3RXR4 | U3RXR3 | U3RXR2 | U3RXR1 | U3RXR0 |
| bit 15 | | | | | | | bit 8 |

| | | | | | | | |
|-------|-----|-----|-----|-----|-----|-----|-------|
| U-0 | U-0 | U-0 | U-0 | U-0 | U-0 | U-0 | U-0 |
| — | — | — | — | — | — | — | — |
| bit 7 | | | | | | | bit 0 |

Legend:

R = Readable bit W = Writable bit U = Unimplemented bit, read as '0'
 -n = Value at POR '1' = Bit is set '0' = Bit is cleared x = Bit is unknown

bit 15-14 **Unimplemented:** Read as '0'
 bit 13-8 **U3RXR<5:0>:** Assign UART3 Receive (U3RX) to Corresponding RPn or RPIn Pin bits
 bit 7-0 **Unimplemented:** Read as '0'

PIC24FJ256DA210 FAMILY

[查询PIC24FJ256DA106供应商](#)

REGISTER 10-20: RPINR18: PERIPHERAL PIN SELECT INPUT REGISTER 18

| | | | | | | | |
|--------|-----|---------|---------|---------|---------|---------|---------|
| U-0 | U-0 | R/W-1 | R/W-1 | R/W-1 | R/W-1 | R/W-1 | R/W-1 |
| — | — | U1CTSR5 | U1CTSR4 | U1CTSR3 | U1CTSR2 | U1CTSR1 | U1CTSR0 |
| bit 15 | | | | | | | bit 8 |

| | | | | | | | |
|-------|-----|--------|--------|--------|--------|--------|--------|
| U-0 | U-0 | R/W-1 | R/W-1 | R/W-1 | R/W-1 | R/W-1 | R/W-1 |
| — | — | U1RXR5 | U1RXR4 | U1RXR3 | U1RXR2 | U1RXR1 | U1RXR0 |
| bit 7 | | | | | | | bit 0 |

Legend:

R = Readable bit W = Writable bit U = Unimplemented bit, read as '0'
 -n = Value at POR '1' = Bit is set '0' = Bit is cleared x = Bit is unknown

- bit 15-14 **Unimplemented:** Read as '0'
- bit 13-8 **U1CTSR<5:0>:** Assign UART1 Clear to Send ($\overline{U1CTS}$) to Corresponding RPn or RPIIn Pin bits
- bit 7-6 **Unimplemented:** Read as '0'
- bit 5-0 **U1RXR<5:0>:** Assign UART1 Receive (U1RX) to Corresponding RPn or RPIIn Pin bits

REGISTER 10-21: RPINR19: PERIPHERAL PIN SELECT INPUT REGISTER 19

| | | | | | | | |
|--------|-----|---------|---------|---------|---------|---------|---------|
| U-0 | U-0 | R/W-1 | R/W-1 | R/W-1 | R/W-1 | R/W-1 | R/W-1 |
| — | — | U2CTSR5 | U2CTSR4 | U2CTSR3 | U2CTSR2 | U2CTSR1 | U2CTSR0 |
| bit 15 | | | | | | | bit 8 |

| | | | | | | | |
|-------|-----|--------|--------|--------|--------|--------|--------|
| U-0 | U-0 | R/W-1 | R/W-1 | R/W-1 | R/W-1 | R/W-1 | R/W-1 |
| — | — | U2RXR5 | U2RXR4 | U2RXR3 | U2RXR2 | U2RXR1 | U2RXR0 |
| bit 7 | | | | | | | bit 0 |

Legend:

R = Readable bit W = Writable bit U = Unimplemented bit, read as '0'
 -n = Value at POR '1' = Bit is set '0' = Bit is cleared x = Bit is unknown

- bit 15-14 **Unimplemented:** Read as '0'
- bit 13-8 **U2CTSR<5:0>:** Assign UART2 Clear to Send ($\overline{U2CTS}$) to Corresponding RPn or RPIIn Pin bits
- bit 7-6 **Unimplemented:** Read as '0'
- bit 5-0 **U2RXR<5:0>:** Assign UART2 Receive (U2RX) to Corresponding RPn or RPIIn Pin bits

PIC24FJ256DA210 FAMILY

[查询PIC24FJ256DA106供应商](#)

REGISTER 10-22: RPINR20: PERIPHERAL PIN SELECT INPUT REGISTER 20

| | | | | | | | |
|--------|-----|--------|--------|--------|--------|--------|--------|
| U-0 | U-0 | R/W-1 | R/W-1 | R/W-1 | R/W-1 | R/W-1 | R/W-1 |
| — | — | SCK1R5 | SCK1R4 | SCK1R3 | SCK1R2 | SCK1R1 | SCK1R0 |
| bit 15 | | | | | | | bit 8 |

| | | | | | | | |
|-------|-----|--------|--------|--------|--------|--------|--------|
| U-0 | U-0 | R/W-1 | R/W-1 | R/W-1 | R/W-1 | R/W-1 | R/W-1 |
| — | — | SDI1R5 | SDI1R4 | SDI1R3 | SDI1R2 | SDI1R1 | SDI1R0 |
| bit 7 | | | | | | | bit 0 |

Legend:

R = Readable bit W = Writable bit U = Unimplemented bit, read as '0'
 -n = Value at POR '1' = Bit is set '0' = Bit is cleared x = Bit is unknown

- bit 15-14 **Unimplemented:** Read as '0'
- bit 13-8 **SCK1R<5:0>:** Assign SPI1 Clock Input (SCK1IN) to Corresponding RPN or RPN Pin bits
- bit 7-6 **Unimplemented:** Read as '0'
- bit 5-0 **SDI1R<5:0>:** Assign SPI1 Data Input (SDI1) to Corresponding RPN or RPN Pin bits

REGISTER 10-23: RPINR21: PERIPHERAL PIN SELECT INPUT REGISTER 21

| | | | | | | | |
|--------|-----|---------|---------|---------|---------|---------|---------|
| U-0 | U-0 | R/W-1 | R/W-1 | R/W-1 | R/W-1 | R/W-1 | R/W-1 |
| — | — | U3CTSR5 | U3CTSR4 | U3CTSR3 | U3CTSR2 | U3CTSR1 | U3CTSR0 |
| bit 15 | | | | | | | bit 8 |

| | | | | | | | |
|-------|-----|-------|-------|-------|-------|-------|-------|
| U-0 | U-0 | R/W-1 | R/W-1 | R/W-1 | R/W-1 | R/W-1 | R/W-1 |
| — | — | SS1R5 | SS1R4 | SS1R3 | SS1R2 | SS1R1 | SS1R0 |
| bit 7 | | | | | | | bit 0 |

Legend:

R = Readable bit W = Writable bit U = Unimplemented bit, read as '0'
 -n = Value at POR '1' = Bit is set '0' = Bit is cleared x = Bit is unknown

- bit 15-14 **Unimplemented:** Read as '0'
- bit 13-8 **U3CTSR<5:0>:** Assign UART3 Clear to Send ($\overline{U3CTS}$) to Corresponding RPN or RPN Pin bits
- bit 7-6 **Unimplemented:** Read as '0'
- bit 5-0 **SS1R<5:0>:** Assign SPI1 Slave Select Input (SS1IN) to Corresponding RPN or RPN Pin bits

PIC24FJ256DA210 FAMILY

[查询PIC24FJ256DA106供应商](#)

REGISTER 10-24: RPINR22: PERIPHERAL PIN SELECT INPUT REGISTER 22

| | | | | | | | |
|--------|-----|--------|--------|--------|--------|--------|--------|
| U-0 | U-0 | R/W-1 | R/W-1 | R/W-1 | R/W-1 | R/W-1 | R/W-1 |
| — | — | SCK2R5 | SCK2R4 | SCK2R3 | SCK2R2 | SCK2R1 | SCK2R0 |
| bit 15 | | | | | | | bit 8 |

| | | | | | | | |
|-------|-----|--------|--------|--------|--------|--------|--------|
| U-0 | U-0 | R/W-1 | R/W-1 | R/W-1 | R/W-1 | R/W-1 | R/W-1 |
| — | — | SDI2R5 | SDI2R4 | SDI2R3 | SDI2R2 | SDI2R1 | SDI2R0 |
| bit 7 | | | | | | | bit 0 |

Legend:

R = Readable bit

W = Writable bit

U = Unimplemented bit, read as '0'

-n = Value at POR

'1' = Bit is set

'0' = Bit is cleared

x = Bit is unknown

bit 15-14 **Unimplemented:** Read as '0'

bit 13-8 **SCK2R<5:0>:** Assign SPI2 Clock Input (SCK2IN) to Corresponding RPN or RPN Pin bits

bit 7-6 **Unimplemented:** Read as '0'

bit 5-0 **SDI2R<5:0>:** Assign SPI2 Data Input (SDI2) to Corresponding RPN or RPN Pin bits

REGISTER 10-25: RPINR23: PERIPHERAL PIN SELECT INPUT REGISTER 23

| | | | | | | | |
|--------|-----|-----|-----|-----|-----|-----|-------|
| U-0 | U-0 | U-0 | U-0 | U-0 | U-0 | U-0 | U-0 |
| — | — | — | — | — | — | — | — |
| bit 15 | | | | | | | bit 8 |

| | | | | | | | |
|-------|-----|-------|-------|-------|-------|-------|-------|
| U-0 | U-0 | R/W-1 | R/W-1 | R/W-1 | R/W-1 | R/W-1 | R/W-1 |
| — | — | SS2R5 | SS2R4 | SS2R3 | SS2R2 | SS2R1 | SS2R0 |
| bit 7 | | | | | | | bit 0 |

Legend:

R = Readable bit

W = Writable bit

U = Unimplemented bit, read as '0'

-n = Value at POR

'1' = Bit is set

'0' = Bit is cleared

x = Bit is unknown

bit 15-6 **Unimplemented:** Read as '0'

bit 5-0 **SS2R<5:0>:** Assign SPI2 Slave Select Input (SS2IN) to Corresponding RPN or RPN Pin bits

PIC24FJ256DA210 FAMILY

[查询PIC24FJ256DA106供应商](#)

REGISTER 10-26: RPINR27: PERIPHERAL PIN SELECT INPUT REGISTER 27

| | | | | | | | |
|--------|-----|---------|---------|---------|---------|---------|---------|
| U-0 | U-0 | R/W-1 | R/W-1 | R/W-1 | R/W-1 | R/W-1 | R/W-1 |
| — | — | U4CTSR5 | U4CTSR4 | U4CTSR3 | U4CTSR2 | U4CTSR1 | U4CTSR0 |
| bit 15 | | | | | | | bit 8 |

| | | | | | | | |
|-------|-----|--------|--------|--------|--------|--------|--------|
| U-0 | U-0 | R/W-1 | R/W-1 | R/W-1 | R/W-1 | R/W-1 | R/W-1 |
| — | — | U4RXR5 | U4RXR4 | U4RXR3 | U4RXR2 | U4RXR1 | U4RXR0 |
| bit 7 | | | | | | | bit 0 |

Legend:

R = Readable bit W = Writable bit U = Unimplemented bit, read as '0'
 -n = Value at POR '1' = Bit is set '0' = Bit is cleared x = Bit is unknown

- bit 15-14 **Unimplemented:** Read as '0'
- bit 13-8 **U4CTSR<5:0>:** Assign UART4 Clear to Send (U4CTS) to Corresponding RPn or RPIn Pin bits
- bit 7-6 **Unimplemented:** Read as '0'
- bit 5-0 **U4RXR<5:0>:** Assign UART4 Receive (U4RX) to Corresponding RPn or RPIn Pin bits

REGISTER 10-27: RPINR28: PERIPHERAL PIN SELECT INPUT REGISTER 28

| | | | | | | | |
|--------|-----|--------|--------|--------|--------|--------|--------|
| U-0 | U-0 | R/W-1 | R/W-1 | R/W-1 | R/W-1 | R/W-1 | R/W-1 |
| — | — | SCK3R5 | SCK3R4 | SCK3R3 | SCK3R2 | SCK3R1 | SCK3R0 |
| bit 15 | | | | | | | bit 8 |

| | | | | | | | |
|-------|-----|--------|--------|--------|--------|--------|--------|
| U-0 | U-0 | R/W-1 | R/W-1 | R/W-1 | R/W-1 | R/W-1 | R/W-1 |
| — | — | SDI3R5 | SDI3R4 | SDI3R3 | SDI3R2 | SDI3R1 | SDI3R0 |
| bit 7 | | | | | | | bit 0 |

Legend:

R = Readable bit W = Writable bit U = Unimplemented bit, read as '0'
 -n = Value at POR '1' = Bit is set '0' = Bit is cleared x = Bit is unknown

- bit 15-14 **Unimplemented:** Read as '0'
- bit 13-8 **SCK3R<5:0>:** Assign SPI3 Clock Input (SCK3IN) to Corresponding RPn or RPIn Pin bits
- bit 7-6 **Unimplemented:** Read as '0'
- bit 5-0 **SDI3R<5:0>:** Assign SPI3 Data Input (SDI3) to Corresponding RPn or RPIn Pin bits

PIC24FJ256DA210 FAMILY

[查询PIC24FJ256DA106供应商](#)

REGISTER 10-28: RPINR29: PERIPHERAL PIN SELECT INPUT REGISTER 29

| | | | | | | | |
|--------|-----|-----|-----|-----|-----|-----|-------|
| U-0 | U-0 | U-0 | U-0 | U-0 | U-0 | U-0 | U-0 |
| — | — | — | — | — | — | — | — |
| bit 15 | | | | | | | bit 8 |

| | | | | | | | |
|-------|-----|-------|-------|-------|-------|-------|-------|
| U-0 | U-0 | R/W-1 | R/W-1 | R/W-1 | R/W-1 | R/W-1 | R/W-1 |
| — | — | SS3R5 | SS3R4 | SS3R3 | SS3R2 | SS3R1 | SS3R0 |
| bit 7 | | | | | | | bit 0 |

Legend:

R = Readable bit

W = Writable bit

U = Unimplemented bit, read as '0'

-n = Value at POR

'1' = Bit is set

'0' = Bit is cleared

x = Bit is unknown

bit 15-6 **Unimplemented:** Read as '0'

bit 5-0 **SS3R<5:0>:** Assign SPI3 Slave Select Input (SS31IN) to Corresponding RPn or RPIIn Pin bits

PIC24FJ256DA210 FAMILY

[查询PIC24FJ256DA106供应商](#)

REGISTER 10-29: RPOR0: PERIPHERAL PIN SELECT OUTPUT REGISTER 0

| | | | | | | | |
|--------|-----|-------|-------|-------|-------|-------|-------|
| U-0 | U-0 | R/W-0 | R/W-0 | R/W-0 | R/W-0 | R/W-0 | R/W-0 |
| — | — | RP1R5 | RP1R4 | RP1R3 | RP1R2 | RP1R1 | RP1R0 |
| bit 15 | | | | | | | bit 8 |

| | | | | | | | |
|-------|-----|-------|-------|-------|-------|-------|-------|
| U-0 | U-0 | R/W-0 | R/W-0 | R/W-0 | R/W-0 | R/W-0 | R/W-0 |
| — | — | RP0R5 | RP0R4 | RP0R3 | RP0R2 | RP0R1 | RP0R0 |
| bit 7 | | | | | | | bit 0 |

Legend:

R = Readable bit

W = Writable bit

U = Unimplemented bit, read as '0'

-n = Value at POR

'1' = Bit is set

'0' = Bit is cleared

x = Bit is unknown

bit 15-14 **Unimplemented:** Read as '0'

bit 13-8 **RP1R<5:0>:** RP1 Output Pin Mapping bits

Peripheral output number n is assigned to pin, RP1 (see Table 10-4 for peripheral function numbers).

bit 7-6 **Unimplemented:** Read as '0'

bit 5-0 **RP0R<5:0>:** RP0 Output Pin Mapping bits

Peripheral output number n is assigned to pin, RP0 (see Table 10-4 for peripheral function numbers).

REGISTER 10-30: RPOR1: PERIPHERAL PIN SELECT OUTPUT REGISTER 1

| | | | | | | | |
|--------|-----|-------|-------|-------|-------|-------|-------|
| U-0 | U-0 | R/W-0 | R/W-0 | R/W-0 | R/W-0 | R/W-0 | R/W-0 |
| — | — | RP3R5 | RP3R4 | RP3R3 | RP3R2 | RP3R1 | RP3R0 |
| bit 15 | | | | | | | bit 8 |

| | | | | | | | |
|-------|-----|-------|-------|-------|-------|-------|-------|
| U-0 | U-0 | R/W-0 | R/W-0 | R/W-0 | R/W-0 | R/W-0 | R/W-0 |
| — | — | RP2R5 | RP2R4 | RP2R3 | RP2R2 | RP2R1 | RP2R0 |
| bit 7 | | | | | | | bit 0 |

Legend:

R = Readable bit

W = Writable bit

U = Unimplemented bit, read as '0'

-n = Value at POR

'1' = Bit is set

'0' = Bit is cleared

x = Bit is unknown

bit 15-14 **Unimplemented:** Read as '0'

bit 13-8 **RP3R<5:0>:** RP3 Output Pin Mapping bits

Peripheral output number n is assigned to pin, RP3 (see Table 10-4 for peripheral function numbers).

bit 7-6 **Unimplemented:** Read as '0'

bit 5-0 **RP2R<5:0>:** RP2 Output Pin Mapping bits

Peripheral output number n is assigned to pin, RP2 (see Table 10-4 for peripheral function numbers).

PIC24FJ256DA210 FAMILY

[查询PIC24FJ256DA106供应商](#)

REGISTER 10-31: RPOR2: PERIPHERAL PIN SELECT OUTPUT REGISTER 2

| | | | | | | | |
|--------|-----|----------------------|----------------------|----------------------|----------------------|----------------------|----------------------|
| U-0 | U-0 | R/W-0 | R/W-0 | R/W-0 | R/W-0 | R/W-0 | R/W-0 |
| — | — | RP5R5 ⁽¹⁾ | RP5R4 ⁽¹⁾ | RP5R3 ⁽¹⁾ | RP5R2 ⁽¹⁾ | RP5R1 ⁽¹⁾ | RP5R0 ⁽¹⁾ |
| bit 15 | | | | | | | bit 8 |

| | | | | | | | |
|-------|-----|-------|-------|-------|-------|-------|-------|
| U-0 | U-0 | R/W-0 | R/W-0 | R/W-0 | R/W-0 | R/W-0 | R/W-0 |
| — | — | RP4R5 | RP4R4 | RP4R3 | RP4R2 | RP4R1 | RP4R0 |
| bit 7 | | | | | | | bit 0 |

Legend:

R = Readable bit W = Writable bit U = Unimplemented bit, read as '0'
 -n = Value at POR '1' = Bit is set '0' = Bit is cleared x = Bit is unknown

- bit 15-14 **Unimplemented:** Read as '0'
- bit 13-8 **RP5R<5:0>:** RP5 Output Pin Mapping bits⁽¹⁾
Peripheral output number n is assigned to pin, RP5 (see Table 10-4 for peripheral function numbers).
- bit 7-6 **Unimplemented:** Read as '0'
- bit 5-0 **RP4R<5:0>:** RP4 Output Pin Mapping bits
Peripheral output number n is assigned to pin, RP4 (see Table 10-4 for peripheral function numbers).

Note 1: Unimplemented in 64-pin devices; read as '0'.

REGISTER 10-32: RPOR3: PERIPHERAL PIN SELECT OUTPUT REGISTER 3

| | | | | | | | |
|--------|-----|-------|-------|-------|-------|-------|-------|
| U-0 | U-0 | R/W-0 | R/W-0 | R/W-0 | R/W-0 | R/W-0 | R/W-0 |
| — | — | RP7R5 | RP7R4 | RP7R3 | RP7R2 | RP7R1 | RP7R0 |
| bit 15 | | | | | | | bit 8 |

| | | | | | | | |
|-------|-----|-------|-------|-------|-------|-------|-------|
| U-0 | U-0 | R/W-0 | R/W-0 | R/W-0 | R/W-0 | R/W-0 | R/W-0 |
| — | — | RP6R5 | RP6R4 | RP6R3 | RP6R2 | RP6R1 | RP6R0 |
| bit 7 | | | | | | | bit 0 |

Legend:

R = Readable bit W = Writable bit U = Unimplemented bit, read as '0'
 -n = Value at POR '1' = Bit is set '0' = Bit is cleared x = Bit is unknown

- bit 15-14 **Unimplemented:** Read as '0'
- bit 13-8 **RP7R<5:0>:** RP7 Output Pin Mapping bits
Peripheral output number n is assigned to pin, RP7 (see Table 10-4 for peripheral function numbers).
- bit 7-6 **Unimplemented:** Read as '0'
- bit 5-0 **RP6R<5:0>:** RP6 Output Pin Mapping bits
Peripheral output number n is assigned to pin, RP6 (see Table 10-4 for peripheral function numbers).

PIC24FJ256DA210 FAMILY

[查询PIC24FJ256DA106供应商](#)

REGISTER 10-33: RPOR4: PERIPHERAL PIN SELECT OUTPUT REGISTER 4

| | | | | | | | |
|--------|-----|-------|-------|-------|-------|-------|-------|
| U-0 | U-0 | R/W-0 | R/W-0 | R/W-0 | R/W-0 | R/W-0 | R/W-0 |
| — | — | RP9R5 | RP9R4 | RP9R3 | RP9R2 | RP9R1 | RP9R0 |
| bit 15 | | | | | | | bit 8 |

| | | | | | | | |
|-------|-----|-------|-------|-------|-------|-------|-------|
| U-0 | U-0 | R/W-0 | R/W-0 | R/W-0 | R/W-0 | R/W-0 | R/W-0 |
| — | — | RP8R5 | RP8R4 | RP8R3 | RP8R2 | RP8R1 | RP8R0 |
| bit 7 | | | | | | | bit 0 |

Legend:

R = Readable bit

W = Writable bit

U = Unimplemented bit, read as '0'

-n = Value at POR

'1' = Bit is set

'0' = Bit is cleared

x = Bit is unknown

bit 15-14 **Unimplemented:** Read as '0'

bit 13-8 **RP9R<5:0>:** RP9 Output Pin Mapping bits

Peripheral output number n is assigned to pin, RP9 (see Table 10-4 for peripheral function numbers).

bit 7-6 **Unimplemented:** Read as '0'

bit 5-0 **RP8R<5:0>:** RP8 Output Pin Mapping bits

Peripheral output number n is assigned to pin, RP8 (see Table 10-4 for peripheral function numbers).

REGISTER 10-34: RPOR5: PERIPHERAL PIN SELECT OUTPUT REGISTER 5

| | | | | | | | |
|--------|-----|--------|--------|--------|--------|--------|--------|
| U-0 | U-0 | R/W-0 | R/W-0 | R/W-0 | R/W-0 | R/W-0 | R/W-0 |
| — | — | RP11R5 | RP11R4 | RP11R3 | RP11R2 | RP11R1 | RP11R0 |
| bit 15 | | | | | | | bit 8 |

| | | | | | | | |
|-------|-----|--------|--------|--------|--------|--------|--------|
| U-0 | U-0 | R/W-0 | R/W-0 | R/W-0 | R/W-0 | R/W-0 | R/W-0 |
| — | — | RP10R5 | RP10R4 | RP10R3 | RP10R2 | RP10R1 | RP10R0 |
| bit 7 | | | | | | | bit 0 |

Legend:

R = Readable bit

W = Writable bit

U = Unimplemented bit, read as '0'

-n = Value at POR

'1' = Bit is set

'0' = Bit is cleared

x = Bit is unknown

bit 15-14 **Unimplemented:** Read as '0'

bit 13-8 **RP11R<5:0>:** RP11 Output Pin Mapping bits

Peripheral output number n is assigned to pin, RP11 (see Table 10-4 for peripheral function numbers).

bit 7-6 **Unimplemented:** Read as '0'

bit 5-0 **RP10R<5:0>:** RP10 Output Pin Mapping bits

Peripheral output number n is assigned to pin, RP10 (see Table 10-4 for peripheral function numbers).

PIC24FJ256DA210 FAMILY

[查询PIC24FJ256DA106供应商](#)

REGISTER 10-35: RPOR6: PERIPHERAL PIN SELECT OUTPUT REGISTER 6

| | | | | | | | |
|--------|-----|--------|--------|--------|--------|--------|--------|
| U-0 | U-0 | R/W-0 | R/W-0 | R/W-0 | R/W-0 | R/W-0 | R/W-0 |
| — | — | RP13R5 | RP13R4 | RP13R3 | RP13R2 | RP13R1 | RP13R0 |
| bit 15 | | | | | | | bit 8 |

| | | | | | | | |
|-------|-----|--------|--------|--------|--------|--------|--------|
| U-0 | U-0 | R/W-0 | R/W-0 | R/W-0 | R/W-0 | R/W-0 | R/W-0 |
| — | — | RP12R5 | RP12R4 | RP12R3 | RP12R2 | RP12R1 | RP12R0 |
| bit 7 | | | | | | | bit 0 |

Legend:

R = Readable bit
-n = Value at POR

W = Writable bit
'1' = Bit is set

U = Unimplemented bit, read as '0'
'0' = Bit is cleared
x = Bit is unknown

bit 15-14 **Unimplemented:** Read as '0'

bit 13-8 **RP13R<5:0>:** RP13 Output Pin Mapping bits
Peripheral output number n is assigned to pin, RP13 (see Table 10-4 for peripheral function numbers).

bit 7-6 **Unimplemented:** Read as '0'

bit 5-0 **RP12R<5:0>:** RP12 Output Pin Mapping bits
Peripheral output number n is assigned to pin, RP12 (see Table 10-4 for peripheral function numbers).

REGISTER 10-36: RPOR7: PERIPHERAL PIN SELECT OUTPUT REGISTER 7

| | | | | | | | |
|--------|-----|-----------------------|-----------------------|-----------------------|-----------------------|-----------------------|-----------------------|
| U-0 | U-0 | R/W-0 | R/W-0 | R/W-0 | R/W-0 | R/W-0 | R/W-0 |
| — | — | RP15R5 ⁽¹⁾ | RP15R4 ⁽¹⁾ | RP15R3 ⁽¹⁾ | RP15R2 ⁽¹⁾ | RP15R1 ⁽¹⁾ | RP15R0 ⁽¹⁾ |
| bit 15 | | | | | | | bit 8 |

| | | | | | | | |
|-------|-----|--------|--------|--------|--------|--------|--------|
| U-0 | U-0 | R/W-0 | R/W-0 | R/W-0 | R/W-0 | R/W-0 | R/W-0 |
| — | — | RP14R5 | RP14R4 | RP14R3 | RP14R2 | RP14R1 | RP14R0 |
| bit 7 | | | | | | | bit 0 |

Legend:

R = Readable bit
-n = Value at POR

W = Writable bit
'1' = Bit is set

U = Unimplemented bit, read as '0'
'0' = Bit is cleared
x = Bit is unknown

bit 15-14 **Unimplemented:** Read as '0'

bit 13-8 **RP15R<5:0>:** RP15 Output Pin Mapping bits⁽¹⁾
Peripheral output number n is assigned to pin, RP0 (see Table 10-4 for peripheral function numbers).

bit 7-6 **Unimplemented:** Read as '0'

bit 5-0 **RP14R<5:0>:** RP14 Output Pin Mapping bits
Peripheral output number n is assigned to pin, RP14 (see Table 10-4 for peripheral function numbers).

Note 1: Unimplemented in 64-pin devices; read as '0'.

PIC24FJ256DA210 FAMILY

[查询PIC24FJ256DA106供应商](#)

REGISTER 10-37: RPOR8: PERIPHERAL PIN SELECT OUTPUT REGISTER 8

| | | | | | | | |
|--------|-----|--------|--------|--------|--------|--------|--------|
| U-0 | U-0 | R/W-0 | R/W-0 | R/W-0 | R/W-0 | R/W-0 | R/W-0 |
| — | — | RP17R5 | RP17R4 | RP17R3 | RP17R2 | RP17R1 | RP17R0 |
| bit 15 | | | | | | | bit 8 |

| | | | | | | | |
|-------|-----|--------|--------|--------|--------|--------|--------|
| U-0 | U-0 | R/W-0 | R/W-0 | R/W-0 | R/W-0 | R/W-0 | R/W-0 |
| — | — | RP16R5 | RP16R4 | RP16R3 | RP16R2 | RP16R1 | RP16R0 |
| bit 7 | | | | | | | bit 0 |

Legend:

R = Readable bit

W = Writable bit

U = Unimplemented bit, read as '0'

-n = Value at POR

'1' = Bit is set

'0' = Bit is cleared

x = Bit is unknown

bit 15-14 **Unimplemented:** Read as '0'

bit 13-8 **RP17R<5:0>:** RP17 Output Pin Mapping bits
Peripheral output number n is assigned to pin, RP17 (see Table 10-4 for peripheral function numbers).

bit 7-6 **Unimplemented:** Read as '0'

bit 5-0 **RP16R<5:0>:** RP16 Output Pin Mapping bits
Peripheral output number n is assigned to pin, RP16 (see Table 10-4 for peripheral function numbers).

REGISTER 10-38: RPOR9: PERIPHERAL PIN SELECT OUTPUT REGISTER 9

| | | | | | | | |
|--------|-----|--------|--------|--------|--------|--------|--------|
| U-0 | U-0 | R/W-0 | R/W-0 | R/W-0 | R/W-0 | R/W-0 | R/W-0 |
| — | — | RP19R5 | RP19R4 | RP19R3 | RP19R2 | RP19R1 | RP19R0 |
| bit 15 | | | | | | | bit 8 |

| | | | | | | | |
|-------|-----|--------|--------|--------|--------|--------|--------|
| U-0 | U-0 | R/W-0 | R/W-0 | R/W-0 | R/W-0 | R/W-0 | R/W-0 |
| — | — | RP18R5 | RP18R4 | RP18R3 | RP18R2 | RP18R1 | RP18R0 |
| bit 7 | | | | | | | bit 0 |

Legend:

R = Readable bit

W = Writable bit

U = Unimplemented bit, read as '0'

-n = Value at POR

'1' = Bit is set

'0' = Bit is cleared

x = Bit is unknown

bit 15-14 **Unimplemented:** Read as '0'

bit 13-8 **RP19R<5:0>:** RP19 Output Pin Mapping bits
Peripheral output number n is assigned to pin, RP19 (see Table 10-4 for peripheral function numbers).

bit 7-6 **Unimplemented:** Read as '0'

bit 5-0 **RP18R<5:0>:** RP18 Output Pin Mapping bits
Peripheral output number n is assigned to pin, RP18 (see Table 10-4 for peripheral function numbers).

PIC24FJ256DA210 FAMILY

[查询PIC24FJ256DA106供应商](#)

REGISTER 10-39: RPOR10: PERIPHERAL PIN SELECT OUTPUT REGISTER 10

| | | | | | | | |
|--------|-----|--------|--------|--------|--------|--------|--------|
| U-0 | U-0 | R/W-0 | R/W-0 | R/W-0 | R/W-0 | R/W-0 | R/W-0 |
| — | — | RP21R5 | RP21R4 | RP21R3 | RP21R2 | RP21R1 | RP21R0 |
| bit 15 | | | | | | | bit 8 |

| | | | | | | | |
|-------|-----|--------|--------|--------|--------|--------|--------|
| U-0 | U-0 | R/W-0 | R/W-0 | R/W-0 | R/W-0 | R/W-0 | R/W-0 |
| — | — | RP20R5 | RP20R4 | RP20R3 | RP20R2 | RP20R1 | RP20R0 |
| bit 7 | | | | | | | bit 0 |

Legend:

R = Readable bit W = Writable bit U = Unimplemented bit, read as '0'
 -n = Value at POR '1' = Bit is set '0' = Bit is cleared x = Bit is unknown

- bit 15-14 **Unimplemented:** Read as '0'
- bit 13-8 **RP21R<5:0>:** RP21 Output Pin Mapping bits
Peripheral output number n is assigned to pin, RP21 (see Table 10-4 for peripheral function numbers).
- bit 7-6 **Unimplemented:** Read as '0'
- bit 5-0 **RP20R<5:0>:** RP20 Output Pin Mapping bits
Peripheral output number n is assigned to pin, RP20 (see Table 10-4 for peripheral function numbers).

REGISTER 10-40: RPOR11: PERIPHERAL PIN SELECT OUTPUT REGISTER 11

| | | | | | | | |
|--------|-----|--------|--------|--------|--------|--------|--------|
| U-0 | U-0 | R/W-0 | R/W-0 | R/W-0 | R/W-0 | R/W-0 | R/W-0 |
| — | — | RP23R5 | RP23R4 | RP23R3 | RP23R2 | RP23R1 | RP23R0 |
| bit 15 | | | | | | | bit 8 |

| | | | | | | | |
|-------|-----|--------|--------|--------|--------|--------|--------|
| U-0 | U-0 | R/W-0 | R/W-0 | R/W-0 | R/W-0 | R/W-0 | R/W-0 |
| — | — | RP22R5 | RP22R4 | RP22R3 | RP22R2 | RP22R1 | RP22R0 |
| bit 7 | | | | | | | bit 0 |

Legend:

R = Readable bit W = Writable bit U = Unimplemented bit, read as '0'
 -n = Value at POR '1' = Bit is set '0' = Bit is cleared x = Bit is unknown

- bit 15-14 **Unimplemented:** Read as '0'
- bit 13-8 **RP23R<5:0>:** RP23 Output Pin Mapping bits
Peripheral output number n is assigned to pin, RP23 (see Table 10-4 for peripheral function numbers).
- bit 7-6 **Unimplemented:** Read as '0'
- bit 5-0 **RP22R<5:0>:** RP22 Output Pin Mapping bits
Peripheral output number n is assigned to pin, RP22 (see Table 10-4 for peripheral function numbers).

PIC24FJ256DA210 FAMILY

[查询PIC24FJ256DA106供应商](#)

REGISTER 10-41: RPOR12: PERIPHERAL PIN SELECT OUTPUT REGISTER 12

| | | | | | | | |
|--------|-----|--------|--------|--------|--------|--------|--------|
| U-0 | U-0 | R/W-0 | R/W-0 | R/W-0 | R/W-0 | R/W-0 | R/W-0 |
| — | — | RP25R5 | RP25R4 | RP25R3 | RP25R2 | RP25R1 | RP25R0 |
| bit 15 | | | | | | | bit 8 |

| | | | | | | | |
|-------|-----|--------|--------|--------|--------|--------|--------|
| U-0 | U-0 | R/W-0 | R/W-0 | R/W-0 | R/W-0 | R/W-0 | R/W-0 |
| — | — | RP24R5 | RP24R4 | RP24R3 | RP24R2 | RP24R1 | RP24R0 |
| bit 7 | | | | | | | bit 0 |

Legend:

R = Readable bit

W = Writable bit

U = Unimplemented bit, read as '0'

-n = Value at POR

'1' = Bit is set

'0' = Bit is cleared

x = Bit is unknown

bit 15-14 **Unimplemented:** Read as '0'

bit 13-8 **RP25R<5:0>:** RP25 Output Pin Mapping bits
Peripheral output number n is assigned to pin, RP25 (see Table 10-4 for peripheral function numbers).

bit 7-6 **Unimplemented:** Read as '0'

bit 5-0 **RP24R<5:0>:** RP24 Output Pin Mapping bits
Peripheral output number n is assigned to pin, RP24 (see Table 10-4 for peripheral function numbers).

REGISTER 10-42: RPOR13: PERIPHERAL PIN SELECT OUTPUT REGISTER 13

| | | | | | | | |
|--------|-----|--------|--------|--------|--------|--------|--------|
| U-0 | U-0 | R/W-0 | R/W-0 | R/W-0 | R/W-0 | R/W-0 | R/W-0 |
| — | — | RP27R5 | RP27R4 | RP27R3 | RP27R2 | RP27R1 | RP27R0 |
| bit 15 | | | | | | | bit 8 |

| | | | | | | | |
|-------|-----|--------|--------|--------|--------|--------|--------|
| U-0 | U-0 | R/W-0 | R/W-0 | R/W-0 | R/W-0 | R/W-0 | R/W-0 |
| — | — | RP26R5 | RP26R4 | RP26R3 | RP26R2 | RP26R1 | RP26R0 |
| bit 7 | | | | | | | bit 0 |

Legend:

R = Readable bit

W = Writable bit

U = Unimplemented bit, read as '0'

-n = Value at POR

'1' = Bit is set

'0' = Bit is cleared

x = Bit is unknown

bit 15-14 **Unimplemented:** Read as '0'

bit 13-8 **RP27R<5:0>:** RP27 Output Pin Mapping bits
Peripheral output number n is assigned to pin, RP27 (see Table 10-4 for peripheral function numbers).

bit 7-6 **Unimplemented:** Read as '0'

bit 5-0 **RP26R<5:0>:** RP26 Output Pin Mapping bits
Peripheral output number n is assigned to pin, RP26 (see Table 10-4 for peripheral function numbers).

PIC24FJ256DA210 FAMILY

[查询PIC24FJ256DA106供应商](#)

REGISTER 10-43: RPOR14: PERIPHERAL PIN SELECT OUTPUT REGISTER 14

| | | | | | | | |
|--------|-----|--------|--------|--------|--------|--------|--------|
| U-0 | U-0 | R/W-0 | R/W-0 | R/W-0 | R/W-0 | R/W-0 | R/W-0 |
| — | — | RP29R5 | RP29R4 | RP29R3 | RP29R2 | RP29R1 | RP29R0 |
| bit 15 | | | | | | | bit 8 |

| | | | | | | | |
|-------|-----|--------|--------|--------|--------|--------|--------|
| U-0 | U-0 | R/W-0 | R/W-0 | R/W-0 | R/W-0 | R/W-0 | R/W-0 |
| — | — | RP28R5 | RP28R4 | RP28R3 | RP28R2 | RP28R1 | RP28R0 |
| bit 7 | | | | | | | bit 0 |

Legend:

R = Readable bit W = Writable bit U = Unimplemented bit, read as '0'
 -n = Value at POR '1' = Bit is set '0' = Bit is cleared x = Bit is unknown

- bit 15-14 **Unimplemented:** Read as '0'
- bit 13-8 **RP29R<5:0>:** RP29 Output Pin Mapping bits
Peripheral output number n is assigned to pin, RP29 (see Table 10-4 for peripheral function numbers).
- bit 7-6 **Unimplemented:** Read as '0'
- bit 5-0 **RP28R<5:0>:** RP28 Output Pin Mapping bits
Peripheral output number n is assigned to pin, RP28 (see Table 10-4 for peripheral function numbers).

REGISTER 10-44: RPOR15: PERIPHERAL PIN SELECT OUTPUT REGISTER 15⁽¹⁾

| | | | | | | | |
|--------|-----|--------|--------|--------|--------|--------|--------|
| U-0 | U-0 | R/W-0 | R/W-0 | R/W-0 | R/W-0 | R/W-0 | R/W-0 |
| — | — | RP31R5 | RP31R4 | RP31R3 | RP31R2 | RP31R1 | RP31R0 |
| bit 15 | | | | | | | bit 8 |

| | | | | | | | |
|-------|-----|--------|--------|--------|--------|--------|--------|
| U-0 | U-0 | R/W-0 | R/W-0 | R/W-0 | R/W-0 | R/W-0 | R/W-0 |
| — | — | RP30R5 | RP30R4 | RP30R3 | RP30R2 | RP30R1 | RP30R0 |
| bit 7 | | | | | | | bit 0 |

Legend:

R = Readable bit W = Writable bit U = Unimplemented bit, read as '0'
 -n = Value at POR '1' = Bit is set '0' = Bit is cleared x = Bit is unknown

- bit 15-14 **Unimplemented:** Read as '0'
- bit 13-8 **RP31R<5:0>:** RP31 Output Pin Mapping bits⁽¹⁾
Peripheral output number n is assigned to pin, RP31 (see Table 10-4 for peripheral function numbers).
- bit 7-6 **Unimplemented:** Read as '0'
- bit 5-0 **RP30R<5:0>:** RP30 Output Pin Mapping bits⁽¹⁾
Peripheral output number n is assigned to pin, RP30 (see Table 10-4 for peripheral function numbers).

Note 1: Unimplemented in 64-pin devices; read as '0'.

PIC24FJ256DA210 FAMILY

[查询PIC24FJ256DA106供应商](#)

NOTES:

PIC24FJ256DA210 FAMILY

[查询PIC24FJ256DA106供应商](#)

11.0 TIMER1

Note: This data sheet summarizes the features of this group of PIC24F devices. It is not intended to be a comprehensive reference source. For more information, refer to the “PIC24F Family Reference Manual”, **Section 14. “Timers” (DS39704)**. The information in this data sheet supersedes the information in the FRM.

The Timer1 module is a 16-bit timer, which can serve as the time counter for the Real-Time Clock (RTC) or operate as a free-running, interval timer/counter. Timer1 can operate in three modes:

- 16-Bit Timer
- 16-Bit Synchronous Counter
- 16-Bit Asynchronous Counter

Timer1 also supports these features:

- Timer Gate Operation
- Selectable Prescaler Settings
- Timer Operation during CPU Idle and Sleep modes
- Interrupt on 16-Bit Period Register Match or Falling Edge of External Gate Signal

Figure 11-1 presents a block diagram of the 16-bit timer module.

To configure Timer1 for operation:

1. Set the TON bit (= 1).
2. Select the timer prescaler ratio using the TCKPS<1:0> bits.
3. Set the Clock and Gating modes using the TCS and TGATE bits.
4. Set or clear the TSYNC bit to configure synchronous or asynchronous operation.
5. Load the timer period value into the PR1 register.
6. If interrupts are required, set the interrupt enable bit, T1IE. Use the priority bits, T1IP<2:0>, to set the interrupt priority.

FIGURE 11-1: 16-BIT TIMER1 MODULE BLOCK DIAGRAM

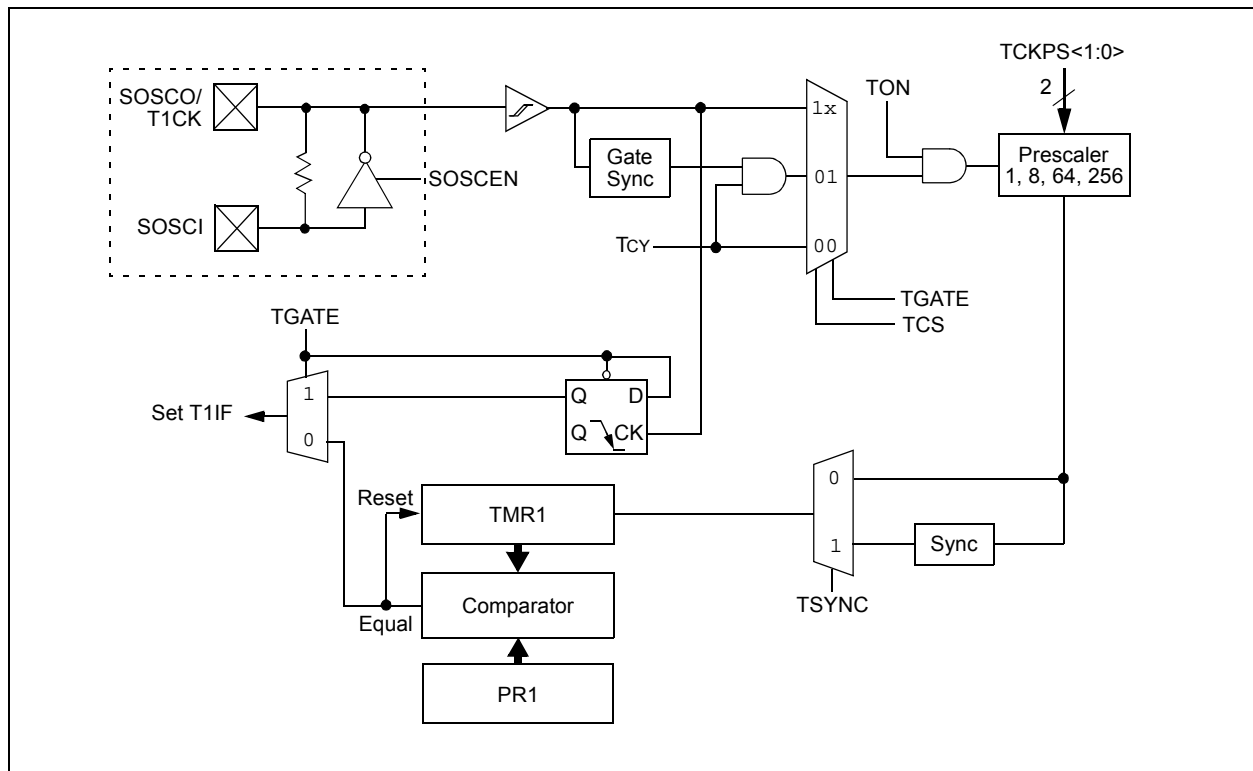

PIC24FJ256DA210 FAMILY

[查询PIC24FJ256DA106供应商](#)

REGISTER 11-1: T1CON: TIMER1 CONTROL REGISTER⁽¹⁾

| | | | | | | | |
|--------|-----|-------|-----|-----|-----|-----|-------|
| R/W-0 | U-0 | R/W-0 | U-0 | U-0 | U-0 | U-0 | U-0 |
| TON | — | TSIDL | — | — | — | — | — |
| bit 15 | | | | | | | bit 8 |

| | | | | | | | |
|-------|-------|--------|--------|-----|-------|-------|-------|
| U-0 | R/W-0 | R/W-0 | R/W-0 | U-0 | R/W-0 | R/W-0 | U-0 |
| — | TGATE | TCKPS1 | TCKPS0 | — | TSYNC | TCS | — |
| bit 7 | | | | | | | bit 0 |

Legend:

R = Readable bit

W = Writable bit

U = Unimplemented bit, read as '0'

-n = Value at POR

'1' = Bit is set

'0' = Bit is cleared

x = Bit is unknown

- bit 15 **TON:** Timer1 On bit
 1 = Starts 16-bit Timer1
 0 = Stops 16-bit Timer1
- bit 14 **Unimplemented:** Read as '0'
- bit 13 **TSIDL:** Stop in Idle Mode bit
 1 = Discontinue module operation when device enters Idle mode
 0 = Continue module operation in Idle mode
- bit 12-7 **Unimplemented:** Read as '0'
- bit 6 **TGATE:** Timer1 Gated Time Accumulation Enable bit
When TCS = 1:
 This bit is ignored.
When TCS = 0:
 1 = Gated time accumulation enabled
 0 = Gated time accumulation disabled
- bit 5-4 **TCKPS<1:0>:** Timer1 Input Clock Prescale Select bits
 11 = 1:256
 10 = 1:64
 01 = 1:8
 00 = 1:1
- bit 3 **Unimplemented:** Read as '0'
- bit 2 **TSYNC:** Timer1 External Clock Input Synchronization Select bit
When TCS = 1:
 1 = Synchronize external clock input
 0 = Do not synchronize external clock input
When TCS = 0:
 This bit is ignored.
- bit 1 **TCS:** Timer1 Clock Source Select bit
 1 = External clock from T1CK pin (on the rising edge)
 0 = Internal clock (Fosc/2)
- bit 0 **Unimplemented:** Read as '0'

Note 1: Changing the value of TxCON while the timer is running (TON = 1) causes the timer prescale counter to reset and is not recommended.

PIC24FJ256DA210 FAMILY

[查询PIC24FJ256DA106供应商](#)

12.0 TIMER2/3 AND TIMER4/5

Note: This data sheet summarizes the features of this group of PIC24F devices. It is not intended to be a comprehensive reference source. For more information, refer to the “PIC24F Family Reference Manual”, **Section 14. “Timers”** (DS39704). The information in this data sheet supersedes the information in the FRM.

The Timer2/3 and Timer4/5 modules are 32-bit timers, which can also be configured as four independent, 16-bit timers with selectable operating modes.

As 32-bit timers, Timer2/3 and Timer4/5 can each operate in three modes:

- Two independent 16-bit timers with all 16-bit operating modes (except Asynchronous Counter mode)
- Single 32-bit timer
- Single 32-bit synchronous counter

They also support these features:

- Timer Gate Operation
- Selectable Prescaler Settings
- Timer Operation during Idle and Sleep modes
- Interrupt on a 32-Bit Period Register Match
- ADC Event Trigger (only on Timer2/3 in 32-bit mode and Timer3 in 16-bit mode)

Individually, all four of the 16-bit timers can function as synchronous timers or counters. They also offer the features listed above, except for the ADC Event Trigger; this is implemented only on Timer2/3 in 32-bit mode and Timer3 in 16-bit mode. The operating modes and enabled features are determined by setting the appropriate bit(s) in the T2CON, T3CON, T4CON and T5CON registers. T2CON and T4CON are shown in generic form in Register 12-1; T3CON and T5CON are shown in Register 12-2.

For 32-bit timer/counter operation, Timer2 and Timer4 are the least significant word; Timer3 and Timer4 are the most significant word of the 32-bit timers.

Note: For 32-bit operation, T3CON and T5CON control bits are ignored. Only T2CON and T4CON control bits are used for setup and control. Timer2 and Timer4 clock and gate inputs are utilized for the 32-bit timer modules, but an interrupt is generated with the Timer3 or Timer5 interrupt flags.

To configure Timer2/3 or Timer4/5 for 32-bit operation:

1. Set the T32 bit (T2CON<3> or T4CON<3> = 1).
2. Select the prescaler ratio for Timer2 or Timer4 using the TCKPS<1:0> bits.
3. Set the Clock and Gating modes using the TCS and TGATE bits. If TCS is set to an external clock, RPINRx (TxCK) must be configured to an available RPn/RPIn pin. For more information, see **Section 10.4 “Peripheral Pin Select (PPS)”**.
4. Load the timer period value. PR3 (or PR5) will contain the most significant word (msw) of the value while PR2 (or PR4) contains the least significant word (lsw).
5. If interrupts are required, set the interrupt enable bit, T3IE or T5IE; use the priority bits, T3IP<2:0> or T5IP<2:0>, to set the interrupt priority. Note that while Timer2 or Timer4 controls the timer, the interrupt appears as a Timer3 or Timer5 interrupt.
6. Set the TON bit (= 1).

The timer value, at any point, is stored in the register pair, TMR<3:2> (or TMR<5:4>). TMR3 (TMR5) always contains the most significant word of the count, while TMR2 (TMR4) contains the least significant word.

To configure any of the timers for individual 16-bit operation:

1. Clear the T32 bit corresponding to that timer (T2CON<3> for Timer2 and Timer3 or T4CON<3> for Timer4 and Timer5).
2. Select the timer prescaler ratio using the TCKPS<1:0> bits.
3. Set the Clock and Gating modes using the TCS and TGATE bits. See **Section 10.4 “Peripheral Pin Select (PPS)”** for more information.
4. Load the timer period value into the PRx register.
5. If interrupts are required, set the interrupt enable bit, TxIE; use the priority bits, TxIP<2:0>, to set the interrupt priority.
6. Set the TON (TxCON<15> = 1) bit.

PIC24FJ256DA210 FAMILY

[查询PIC24FJ256DA106供应商](#)

FIGURE 12-1: TIMER2/3 AND TIMER4/5 (32-BIT) BLOCK DIAGRAM

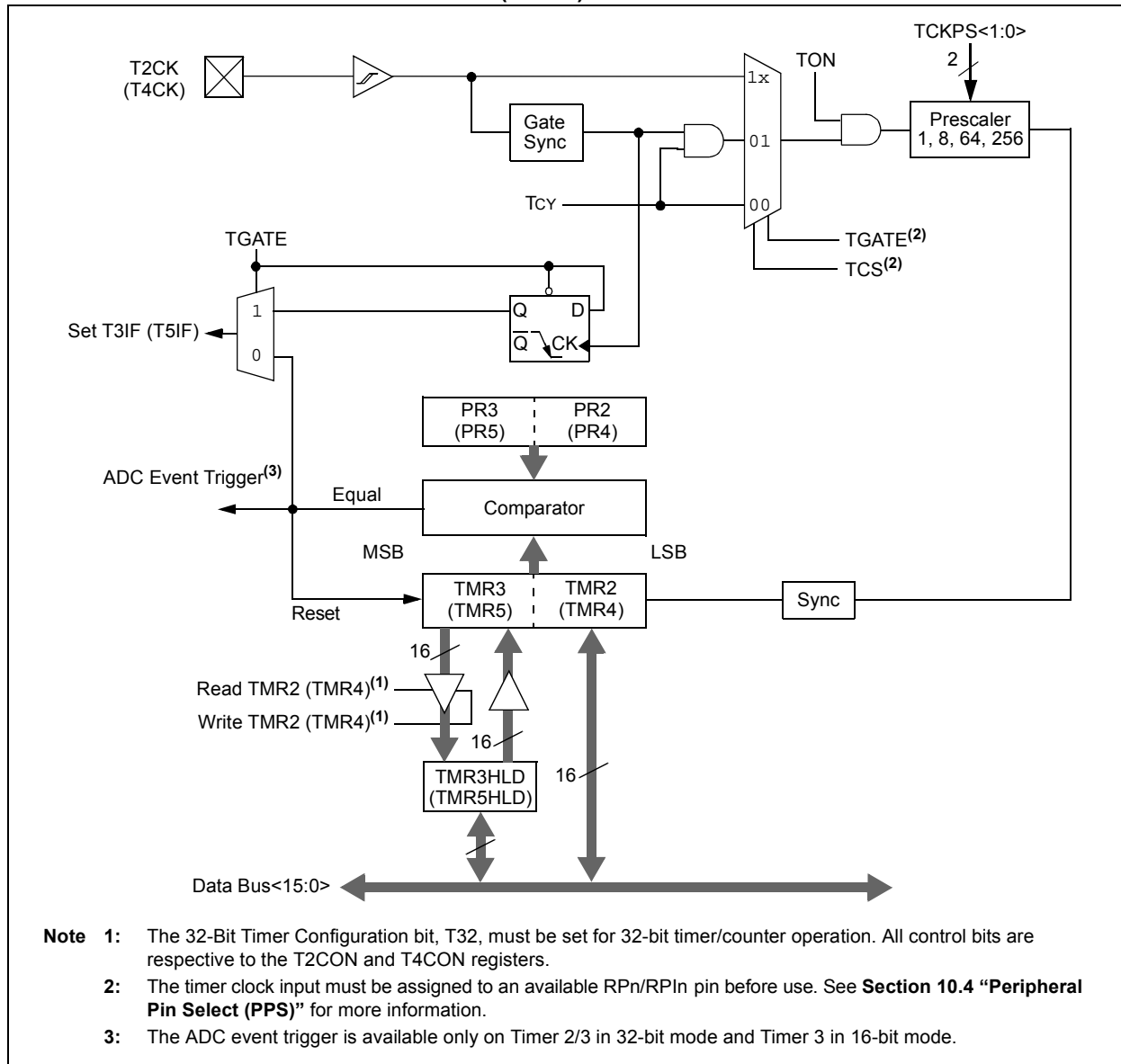

PIC24FJ256DA210 FAMILY

查询PIC24FJ256DA106供应商

FIGURE 12-2: TIMER2 AND TIMER4 (16-BIT SYNCHRONOUS) BLOCK DIAGRAM

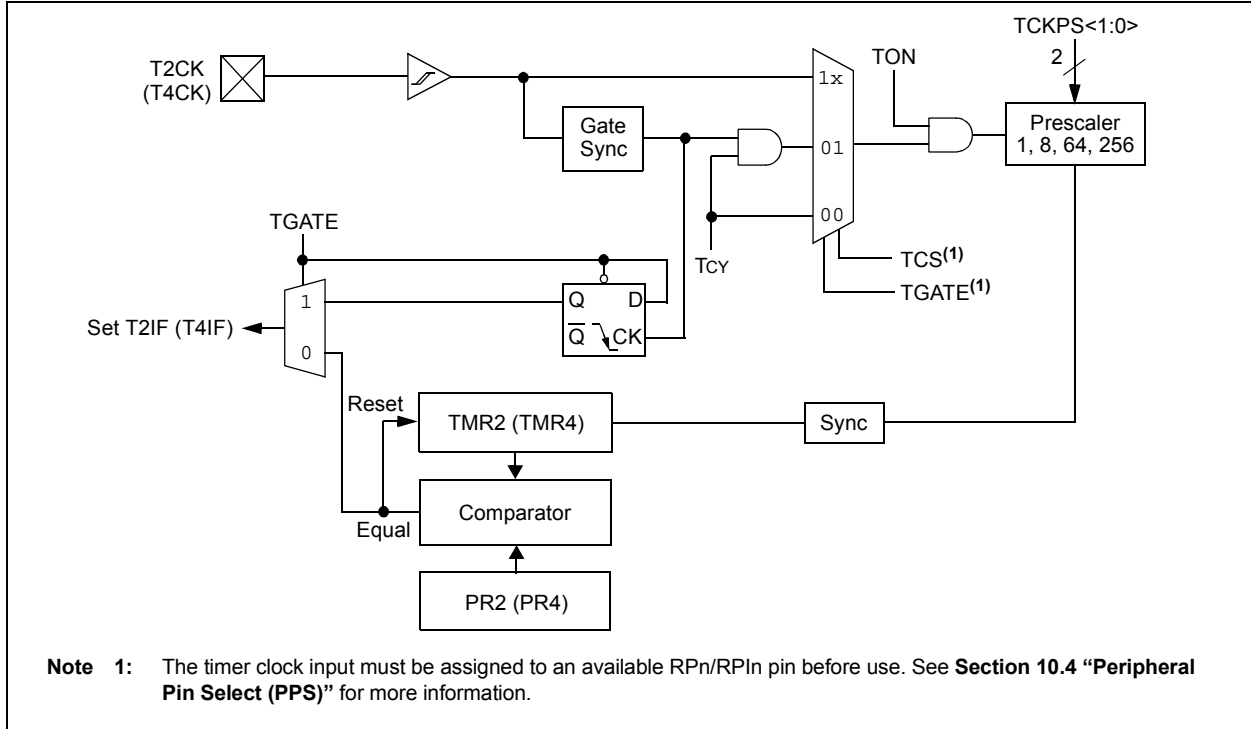
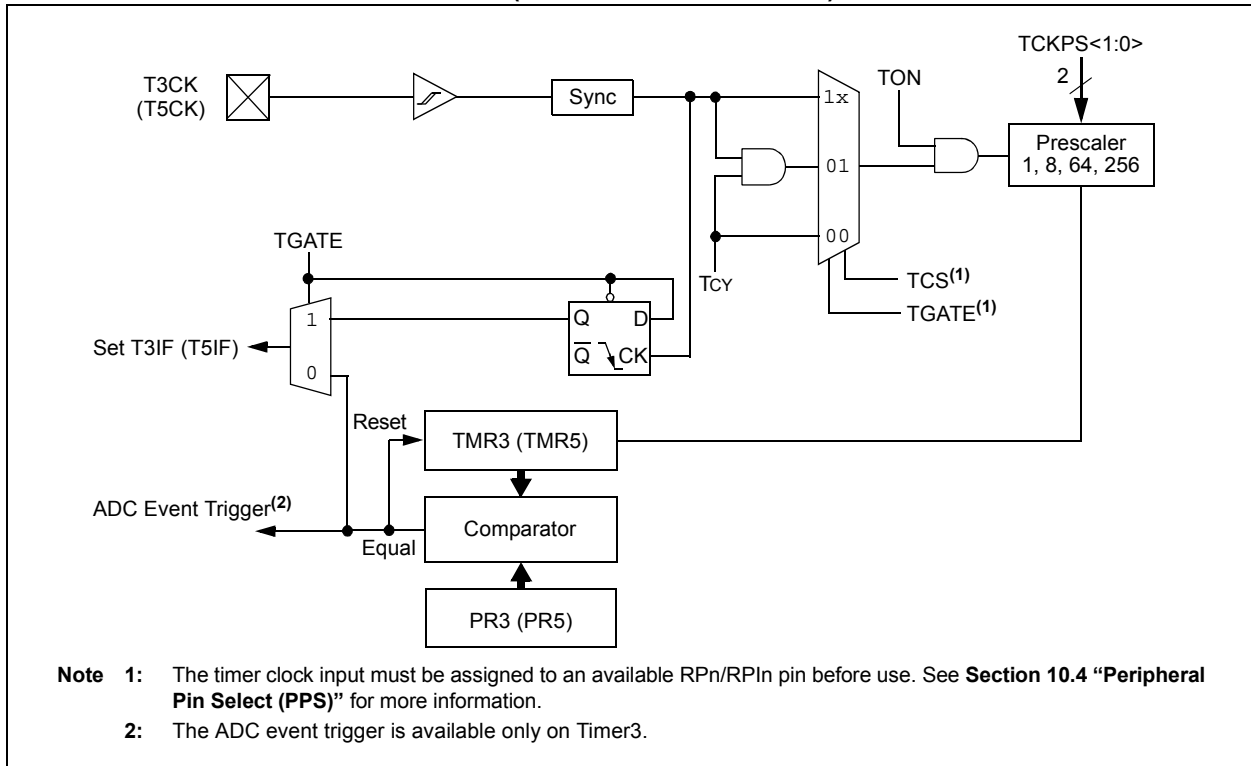

FIGURE 12-3: TIMER3 AND TIMER5 (16-BIT ASYNCHRONOUS) BLOCK DIAGRAM



PIC24FJ256DA210 FAMILY

查询PIC24FJ256DA106供应商

REGISTER 12-1: TxCON: TIMER2 AND TIMER4 CONTROL REGISTER⁽³⁾

| | | | | | | | |
|--------|-----|-------|-----|-----|-----|-----|-------|
| R/W-0 | U-0 | R/W-0 | U-0 | U-0 | U-0 | U-0 | U-0 |
| TON | — | TSIDL | — | — | — | — | — |
| bit 15 | | | | | | | bit 8 |

| | | | | | | | |
|-------|-------|--------|--------|--------------------|-----|--------------------|-------|
| U-0 | R/W-0 | R/W-0 | R/W-0 | R/W-0 | U-0 | R/W-0 | U-0 |
| — | TGATE | TCKPS1 | TCKPS0 | T32 ⁽¹⁾ | — | TCS ⁽²⁾ | — |
| bit 7 | | | | | | | bit 0 |

Legend:

R = Readable bit W = Writable bit U = Unimplemented bit, read as '0'
 -n = Value at POR '1' = Bit is set '0' = Bit is cleared x = Bit is unknown

bit 15 **TON:** Timerx On bit

When TxCON<3> = 1:

1 = Starts 32-bit Timerx/y

0 = Stops 32-bit Timerx/y

When TxCON<3> = 0:

1 = Starts 16-bit Timerx

0 = Stops 16-bit Timerx

bit 14 **Unimplemented:** Read as '0'

bit 13 **TSIDL:** Stop in Idle Mode bit

1 = Discontinue module operation when device enters Idle mode

0 = Continue module operation in Idle mode

bit 12-7 **Unimplemented:** Read as '0'

bit 6 **TGATE:** Timerx Gated Time Accumulation Enable bit

When TCS = 1:

This bit is ignored.

When TCS = 0:

1 = Gated time accumulation enabled

0 = Gated time accumulation disabled

bit 5-4 **TCKPS<1:0>:** Timerx Input Clock Prescale Select bits

11 = 1:256

10 = 1:64

01 = 1:8

00 = 1:1

bit 3 **T32:** 32-Bit Timer Mode Select bit⁽¹⁾

1 = Timerx and Timery form a single 32-bit timer

0 = Timerx and Timery act as two 16-bit timers

In 32-bit mode, T3CON control bits do not affect 32-bit timer operation.

bit 2 **Unimplemented:** Read as '0'

bit 1 **TCS:** Timerx Clock Source Select bit⁽²⁾

1 = External clock from pin, TxCK (on the rising edge)

0 = Internal clock (Fosc/2)

bit 0 **Unimplemented:** Read as '0'

Note 1: In T4CON, the T45 bit is implemented instead of T32 to select 32-bit mode. In 32-bit mode, the T3CON or T5CON control bits do not affect 32-bit timer operation.

2: If TCS = 1, RPINRx (TxCK) must be configured to an available RPN/RPIn pin. For more information, see **Section 10.4 “Peripheral Pin Select (PPS)”**.

3: Changing the value of TxCON while the timer is running (TON = 1) causes the timer prescale counter to reset and is not recommended.

PIC24FJ256DA210 FAMILY

查询PIC24FJ256DA106供应商

REGISTER 12-2: TyCON: TIMER3 AND TIMER5 CONTROL REGISTER⁽³⁾

| | | | | | | | |
|--------------------|-----|----------------------|-----|-----|-----|-----|-------|
| R/W-0 | U-0 | R/W-0 | U-0 | U-0 | U-0 | U-0 | U-0 |
| TON ⁽¹⁾ | — | TSIDL ⁽¹⁾ | — | — | — | — | — |
| bit 15 | | | | | | | bit 8 |

| | | | | | | | |
|-------|----------------------|-----------------------|-----------------------|-----|-----|----------------------|-------|
| U-0 | R/W-0 | R/W-0 | R/W-0 | U-0 | U-0 | R/W-0 | U-0 |
| — | TGATE ⁽¹⁾ | TCKPS1 ⁽¹⁾ | TCKPS0 ⁽¹⁾ | — | — | TCS ^(1,2) | — |
| bit 7 | | | | | | | bit 0 |

Legend:

R = Readable bit W = Writable bit U = Unimplemented bit, read as '0'
 -n = Value at POR '1' = Bit is set '0' = Bit is cleared x = Bit is unknown

- bit 15 **TON:** Timery On bit⁽¹⁾
 1 = Starts 16-bit Timery
 0 = Stops 16-bit Timery
- bit 14 **Unimplemented:** Read as '0'
- bit 13 **TSIDL:** Stop in Idle Mode bit⁽¹⁾
 1 = Discontinue module operation when device enters Idle mode
 0 = Continue module operation in Idle mode
- bit 12-7 **Unimplemented:** Read as '0'
- bit 6 **TGATE:** Timery Gated Time Accumulation Enable bit⁽¹⁾
 When TCS = 1:
 This bit is ignored.
 When TCS = 0:
 1 = Gated time accumulation enabled
 0 = Gated time accumulation disabled
- bit 5-4 **TCKPS<1:0>:** Timery Input Clock Prescale Select bits⁽¹⁾
 11 = 1:256
 10 = 1:64
 01 = 1:8
 00 = 1:1
- bit 3-2 **Unimplemented:** Read as '0'
- bit 1 **TCS:** Timery Clock Source Select bit^(1,2)
 1 = External clock from pin, TyCK (on the rising edge)
 0 = Internal clock (Fosc/2)
- bit 0 **Unimplemented:** Read as '0'

- Note 1:** When 32-bit operation is enabled (T2CON<3> or T4CON<3> = 1), these bits have no effect on Timery operation; all timer functions are set through T2CON and T4CON.
- 2:** If TCS = 1, RPINRx (TxCK) must be configured to an available RPn/RPIn pin. See **Section 10.4 “Peripheral Pin Select (PPS)”** for more information.
- 3:** Changing the value of TyCON while the timer is running (TON = 1) causes the timer prescale counter to reset and is not recommended.

PIC24FJ256DA210 FAMILY

[查询PIC24FJ256DA106供应商](#)

NOTES:

PIC24FJ256DA210 FAMILY

[查询PIC24FJ256DA106供应商](#)

13.0 INPUT CAPTURE WITH DEDICATED TIMERS

Note: This data sheet summarizes the features of this group of PIC24F devices. It is not intended to be a comprehensive reference source. For more information, refer to the “PIC24F Family Reference Manual”, Section 34. “Input Capture with Dedicated Timer” (DS39722). The information in this data sheet supersedes the information in the FRM.

Devices in the PIC24FJ256DA210 family comprise nine independent input capture modules. Each of the modules offers a wide range of configuration and operating options for capturing external pulse events and generating interrupts.

Key features of the input capture module include:

- Hardware configurable for 32-bit operation in all modes by cascading two adjacent modules
- Synchronous and Trigger modes of output compare operation, with up to 30 user-selectable sync/trigger sources available
- A 4-level FIFO buffer for capturing and holding timer values for several events
- Configurable interrupt generation
- Up to 6 clock sources available for each module, driving a separate internal 16-bit counter

The module is controlled through two registers: ICxCON1 (Register 13-1) and ICxCON2 (Register 13-2). A general block diagram of the module is shown in Figure 13-1.

13.1 General Operating Modes

13.1.1 SYNCHRONOUS AND TRIGGER MODES

When the input capture module operates in a free-running mode, the internal 16-bit counter, ICxTMR, counts up continuously, wrapping around from FFFFh to 0000h on each overflow, with its period synchronized to the selected external clock source. When a capture event occurs, the current 16-bit value of the internal counter is written to the FIFO buffer.

In Synchronous mode, the module begins capturing events on the ICx pin as soon as its selected clock source is enabled. Whenever an event occurs on the selected sync source, the internal counter is reset. In Trigger mode, the module waits for a Sync event from another internal module to occur before allowing the internal counter to run.

Standard, free-running operation is selected by setting the SYNCSEL bits (ICxCON2<4:0>) to ‘00000’ and clearing the ICTRIG bit (ICxCON2<7>). Synchronous and Trigger modes are selected any time the SYNCSEL bits are set to any value except ‘00000’. The ICTRIG bit selects either Synchronous or Trigger mode; setting the bit selects Trigger mode operation. In both modes, the SYNCSEL bits determine the sync/trigger source.

When the SYNCSEL bits are set to ‘00000’ and ICTRIG is set, the module operates in Software Trigger mode. In this case, capture operations are started by manually setting the TRIGSTAT bit (ICxCON2<6>).

FIGURE 13-1: INPUT CAPTURE BLOCK DIAGRAM

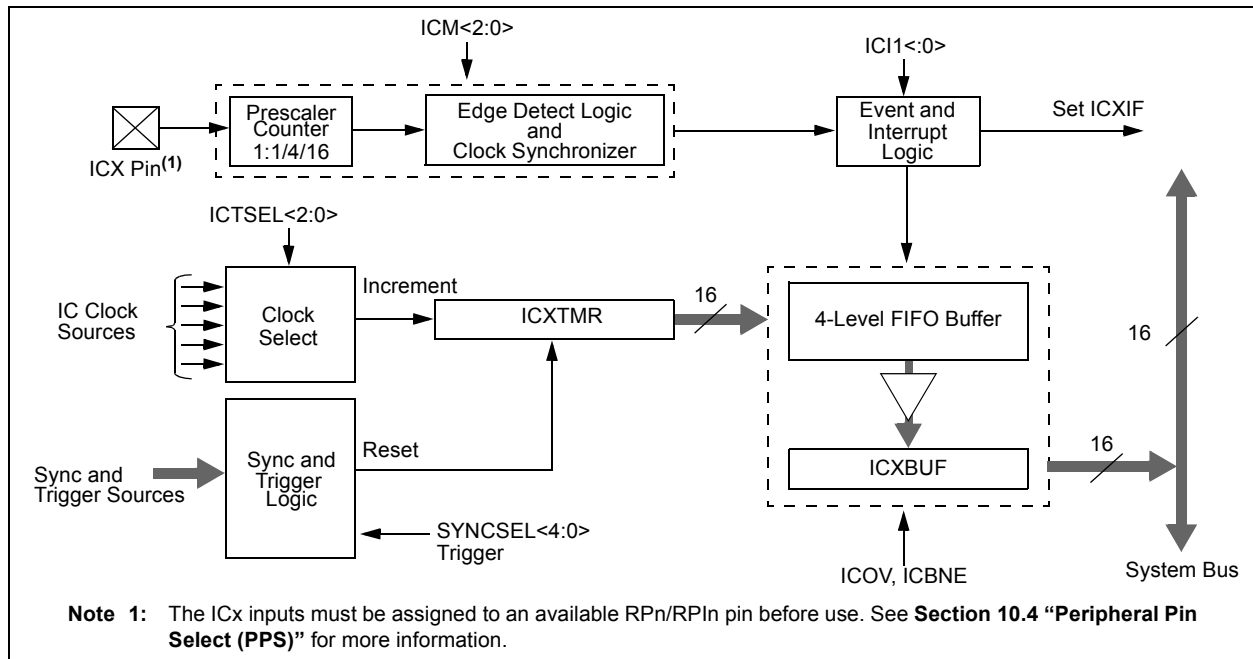

PIC24FJ256DA210 FAMILY

[查询PIC24FJ256DA106供应商](#)

13.1.2 CASCADED (32-BIT) MODE

By default, each module operates independently with its own 16-bit timer. To increase resolution, adjacent even and odd modules can be configured to function as a single 32-bit module. (For example, Modules 1 and 2 are paired, as are Modules 3 and 4, and so on.) The odd numbered module (ICx) provides the Least Significant 16 bits of the 32-bit register pairs and the even module (ICy) provides the Most Significant 16 bits. Wrap-arounds of the ICx registers cause an increment of their corresponding ICy registers.

Cascaded operation is configured in hardware by setting the IC32 bits (ICxCON2<8>) for both modules.

13.2 Capture Operations

The input capture module can be configured to capture timer values and generate interrupts on rising edges on ICx or all transitions on ICx. Captures can be configured to occur on all rising edges or just some (every 4th or 16th). Interrupts can be independently configured to generate on each event or a subset of events.

To set up the module for capture operations:

1. Configure the ICx input for one of the available Peripheral Pin Select pins.
2. If Synchronous mode is to be used, disable the sync source before proceeding.
3. Make sure that any previous data has been removed from the FIFO by reading ICxBUF until the ICBNE bit (ICxCON1<3>) is cleared.
4. Set the SYNCSEL bits (ICxCON2<4:0>) to the desired sync/trigger source.
5. Set the ICTSEL bits (ICxCON1<12:10>) for the desired clock source.
6. Set the ICI bits (ICxCON1<6:5>) to the desired interrupt frequency.
7. Select Synchronous or Trigger mode operation:
 - a) Check that the SYNCSEL bits are not set to '00000'.
 - b) For Synchronous mode, clear the ICTRIG bit (ICxCON2<7>).
 - c) For Trigger mode, set ICTRIG, and clear the TRIGSTAT bit (ICxCON2<6>).
8. Set the ICM bits (ICxCON1<2:0>) to the desired operational mode.
9. Enable the selected sync/trigger source.

For 32-bit cascaded operations, the setup procedure is slightly different:

1. Set the IC32 bits for both modules (ICyCON2<8>) and (ICxCON2<8>), enabling the even numbered module first. This ensures the modules will start functioning in unison.
2. Set the ICTSEL and SYNCSEL bits for both modules to select the same sync/trigger and time base source. Set the even module first, then the odd module. Both modules must use the same ICTSEL and SYNCSEL settings.
3. Clear the ICTRIG bit of the even module (ICyCON2<7>). This forces the module to run in Synchronous mode with the odd module, regardless of its trigger setting.
4. Use the odd module's ICI bits (ICxCON1<6:5>) to set the desired interrupt frequency.
5. Use the ICTRIG bit of the odd module (ICxCON2<7>) to configure Trigger or Synchronous mode operation.

Note: For Synchronous mode operation, enable the sync source as the last step. Both input capture modules are held in Reset until the sync source is enabled.

6. Use the ICM bits of the odd module (ICxCON1<2:0>) to set the desired capture mode.

The module is ready to capture events when the time base and the sync/trigger source are enabled. When the ICBNE bit (ICxCON1<3>) becomes set, at least one capture value is available in the FIFO. Read input capture values from the FIFO until the ICBNE clears to '0'.

For 32-bit operation, read both the ICxBUF and ICyBUF for the full 32-bit timer value (ICxBUF for the lsw, ICyBUF for the msw). At least one capture value is available in the FIFO buffer when the odd module's ICBNE bit (ICxCON1<3>) becomes set. Continue to read the buffer registers until ICBNE is cleared (performed automatically by hardware).

PIC24FJ256DA210 FAMILY

[查询PIC24FJ256DA106供应商](#)

REGISTER 13-1: ICxCON1: INPUT CAPTURE x CONTROL REGISTER 1

| | | | | | | | |
|--------|-----|--------|---------|---------|---------|-------|-----|
| U-0 | U-0 | R/W-0 | R/W-0 | R/W-0 | R/W-0 | U-0 | U-0 |
| — | — | ICSIDL | ICTSEL2 | ICTSEL1 | ICTSEL0 | — | — |
| bit 15 | | | | | | bit 8 | |

| | | | | | | | |
|-------|-------|-------|----------|----------|---------------------|---------------------|---------------------|
| U-0 | R/W-0 | R/W-0 | R-0, HSC | R-0, HSC | R/W-0 | R/W-0 | R/W-0 |
| — | ICI1 | ICI0 | ICOV | ICBNE | ICM2 ⁽¹⁾ | ICM1 ⁽¹⁾ | ICM0 ⁽¹⁾ |
| bit 7 | | | | | | bit 0 | |

| | | | |
|-------------------|---------------------------------------|------------------------------------|--------------------|
| Legend: | HSC = Hardware Settable/Clearable bit | | |
| R = Readable bit | W = Writable bit | U = Unimplemented bit, read as '0' | |
| -n = Value at POR | '1' = Bit is set | '0' = Bit is cleared | x = Bit is unknown |

bit 15-14 **Unimplemented:** Read as '0'

bit 13 **ICSIDL:** Input Capture x Module Stop in Idle Control bit
 1 = Input capture module halts in CPU Idle mode
 0 = Input capture module continues to operate in CPU Idle mode

bit 12-10 **ICTSEL<2:0>:** Input Capture Timer Select bits
 111 = System clock (FOSC/2)
 110 = Reserved
 101 = Reserved
 100 = Timer1
 011 = Timer5
 010 = Timer4
 001 = Timer2
 000 = Timer3

bit 9-7 **Unimplemented:** Read as '0'

bit 6-5 **ICI<1:0>:** Select Number of Captures Per Interrupt bits
 11 = Interrupt on every fourth capture event
 10 = Interrupt on every third capture event
 01 = Interrupt on every second capture event
 00 = Interrupt on every capture event

bit 4 **ICOV:** Input Capture x Overflow Status Flag bit (read-only)
 1 = Input capture overflow occurred
 0 = No input capture overflow occurred

bit 3 **ICBNE:** Input Capture x Buffer Empty Status bit (read-only)
 1 = Input capture buffer is not empty, at least one more capture value can be read
 0 = Input capture buffer is empty

bit 2-0 **ICM<2:0>:** Input Capture Mode Select bits⁽¹⁾
 111 = Interrupt mode: input capture functions as an interrupt pin only when the device is in Sleep or Idle mode (rising edge detect only, all other control bits are not applicable)
 110 = Unused (module disabled)
 101 = Prescaler Capture mode: capture on every 16th rising edge
 100 = Prescaler Capture mode: capture on every 4th rising edge
 011 = Simple Capture mode: capture on every rising edge
 010 = Simple Capture mode: capture on every falling edge
 001 = Edge Detect Capture mode: capture on every edge (rising and falling), ICI<1:0> bits do not control interrupt generation for this mode
 000 = Input capture module turned off

Note 1: The ICx input must also be configured to an available RPN/RPIn pin. For more information, see **Section 10.4 "Peripheral Pin Select (PPS)"**.

PIC24FJ256DA210 FAMILY

[查询PIC24FJ256DA106供应商](#)

REGISTER 13-2: ICxCON2: INPUT CAPTURE x CONTROL REGISTER 2

| | | | | | | | |
|--------|-----|-----|-----|-----|-----|-----|-------|
| U-0 | U-0 | U-0 | U-0 | U-0 | U-0 | U-0 | R/W-0 |
| — | — | — | — | — | — | — | IC32 |
| bit 15 | | | | | | | bit 8 |

| | | | | | | | |
|--------|----------|-----|----------|----------|----------|----------|----------|
| R/W-0 | R/W-0 HS | U-0 | R/W-0 | R/W-1 | R/W-1 | R/W-0 | R/W-1 |
| ICTRIG | TRIGSTAT | — | SYNCSEL4 | SYNCSEL3 | SYNCSEL2 | SYNCSEL1 | SYNCSEL0 |
| bit 7 | | | | | | | bit 0 |

| | | | |
|-------------------|----------------------------|------------------------------------|--------------------|
| Legend: | HS = Hardware Settable bit | | |
| R = Readable bit | W = Writable bit | U = Unimplemented bit, read as '0' | |
| -n = Value at POR | '1' = Bit is set | '0' = Bit is cleared | x = Bit is unknown |

- bit 15-9 **Unimplemented:** Read as '0'
- bit 8 **IC32:** Cascade Two IC Modules Enable bit (32-bit operation)
 1 = ICx and ICy operate in cascade as a 32-bit module (this bit must be set in both modules)
 0 = ICx functions independently as a 16-bit module
- bit 7 **ICTRIG:** ICx Sync/Trigger Select bit
 1 = Trigger ICx from the source designated by the SYNCSELx bits
 0 = Synchronize ICx with the source designated by the SYNCSELx bits
- bit 6 **TRIGSTAT:** Timer Trigger Status bit
 1 = Timer source has been triggered and is running (set in hardware, can be set in software)
 0 = Timer source has not been triggered and is being held clear
- bit 5 **Unimplemented:** Read as '0'
- bit 4-0 **SYNCSEL<4:0>:** Synchronization/Trigger Source Selection bits
 11111 = Reserved
 11110 = Input Capture 9⁽²⁾
 11101 = Input Capture 6⁽²⁾
 11100 = CTMU⁽¹⁾
 11011 = A/D⁽¹⁾
 11010 = Comparator 3⁽¹⁾
 11001 = Comparator 2⁽¹⁾
 11000 = Comparator 1⁽¹⁾
 10111 = Input Capture 4⁽²⁾
 10110 = Input Capture 3⁽²⁾
 10101 = Input Capture 2⁽²⁾
 10100 = Input Capture 1⁽²⁾
 10011 = Input Capture 8⁽²⁾
 10010 = Input Capture 7⁽²⁾
 1000x = Reserved
 01111 = Timer5
 01110 = Timer4
 01101 = Timer3
 01100 = Timer2
 01011 = Timer1
 01010 = Input Capture 5⁽²⁾
 01001 = Output Compare 9
 .
 .
 .
 00010 = Output Compare 2
 00001 = Output Compare 1
 00000 = Not synchronized to any other module

- Note 1:** Use these inputs as trigger sources only and never as sync sources.
Note 2: Never use an IC module as its own trigger source, by selecting this mode.

PIC24FJ256DA210 FAMILY

[查询PIC24FJ256DA106供应商](#)

14.0 OUTPUT COMPARE WITH DEDICATED TIMERS

Note: This data sheet summarizes the features of this group of PIC24F devices. It is not intended to be a comprehensive reference source. For more information, refer to the “PIC24F Family Reference Manual”, Section 35. “Output Compare with Dedicated Timer” (DS39723). The information in this data sheet supersedes the information in the FRM.

Devices in the PIC24FJ256DA210 family feature all of the 9 independent output compare modules. Each of these modules offers a wide range of configuration and operating options for generating pulse trains on internal device events, and can produce pulse-width modulated waveforms for driving power applications.

Key features of the output compare module include:

- Hardware configurable for 32-bit operation in all modes by cascading two adjacent modules
- Synchronous and Trigger modes of output compare operation, with up to 31 user-selectable trigger/sync sources available
- Two separate period registers (a main register, OCxR, and a secondary register, OCxRS) for greater flexibility in generating pulses of varying widths
- Configurable for single pulse or continuous pulse generation on an output event, or continuous PWM waveform generation
- Up to 6 clock sources available for each module, driving a separate internal 16-bit counter

14.1 General Operating Modes

14.1.1 SYNCHRONOUS AND TRIGGER MODES

When the output compare module operates in a free-running mode, the internal 16-bit counter, OCxTMR, runs counts up continuously, wrapping around from 0xFFFF to 0x0000 on each overflow, with its period synchronized to the selected external clock source. Compare or PWM events are generated each time a match between the internal counter and one of the period registers occurs.

In Synchronous mode, the module begins performing its compare or PWM operation as soon as its selected clock source is enabled. Whenever an event occurs on the selected sync source, the module's internal counter is reset. In Trigger mode, the module waits for a sync event from another internal module to occur before allowing the counter to run.

Free-running mode is selected by default or any time that the SYNCSEL bits (OCxCON2<4:0>) are set to '00000'. Synchronous or Trigger modes are selected any time the SYNCSEL bits are set to any value except '00000'. The OCTRIG bit (OCxCON2<7>) selects either Synchronous or Trigger mode; setting the bit selects Trigger mode operation. In both modes, the SYNCSEL bits determine the sync/trigger source.

14.1.2 CASCADED (32-BIT) MODE

By default, each module operates independently with its own set of 16-bit timer and duty cycle registers. To increase resolution, adjacent even and odd modules can be configured to function as a single 32-bit module. (For example, Modules 1 and 2 are paired, as are Modules 3 and 4, and so on.) The odd numbered module (OCx) provides the Least Significant 16 bits of the 32-bit register pairs and the even module (OCy) provides the Most Significant 16 bits. Wrap-arounds of the OCx registers cause an increment of their corresponding OCy registers.

Cascaded operation is configured in hardware by setting the OC32 bit (OCxCON2<8>) for both modules. For more details on cascading, refer to the “PIC24F Family Reference Manual”, Section 35. “Output Compare with Dedicated Timer”.

PIC24FJ256DA210 FAMILY

查询PIC24FJ256DA106供应商

FIGURE 14-1: OUTPUT COMPARE BLOCK DIAGRAM (16-BIT MODE)

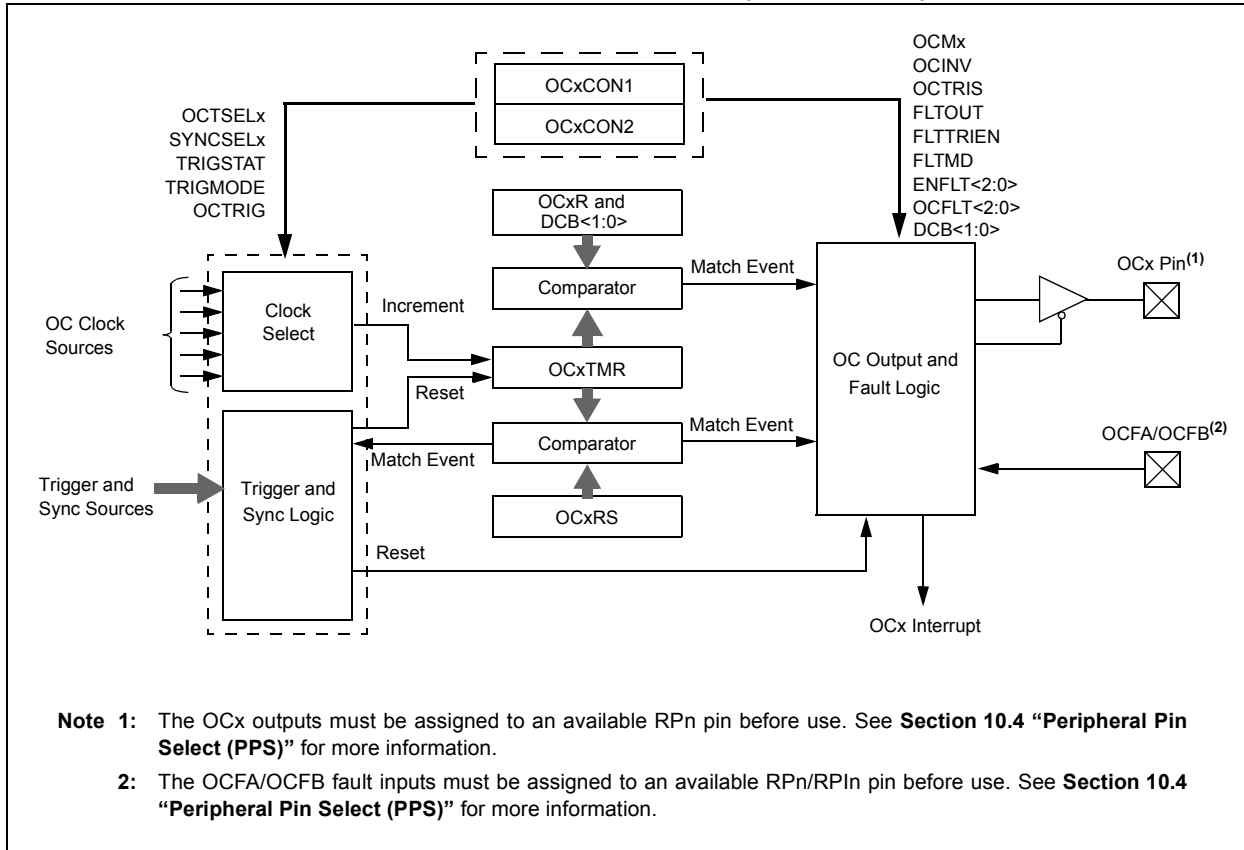

14.2 Compare Operations

In Compare mode (Figure 14-1), the output compare module can be configured for single-shot or continuous pulse generation. It can also repeatedly toggle an output pin on each timer event.

To set up the module for compare operations:

- Configure the OCx output for one of the available Peripheral Pin Select pins.
- Calculate the required values for the OCxR and (for Double Compare modes) OCxRS Duty Cycle registers:
 - Determine the instruction clock cycle time. Take into account the frequency of the external clock to the timer source (if one is used) and the timer prescaler settings.
 - Calculate time to the rising edge of the output pulse relative to the timer start value (0000h).
 - Calculate the time to the falling edge of the pulse based on the desired pulse width and the time to the rising edge of the pulse.
- Write the rising edge value to OCxR and the falling edge value to OCxRS.
- Set the Timer Period register, PRy, to a value equal to or greater than the value in OCxRS.
- Set the OCM<2:0> bits for the appropriate compare operation (= 0xx).
- For Trigger mode operations, set OCTRIS to enable Trigger mode. Set or clear TRIGMODE to configure trigger operation and TRIGSTAT to select a hardware or software trigger. For Synchronous mode, clear OCTRIS.
- Set the SYNCSEL<4:0> bits to configure the trigger or synchronization source. If free-running timer operation is required, set the SYNCSEL bits to '00000' (no sync/trigger source).
- Select the time base source with the OCTSEL<2:0> bits. If necessary, set the TON bits for the selected timer, which enables the compare time base to count. Synchronous mode operation starts as soon as the time base is enabled; Trigger mode operation starts after a trigger source event occurs.

PIC24FJ256DA210 FAMILY

[查询PIC24FJ256DA106供应商](#)

For 32-bit cascaded operation, these steps are also necessary:

1. Set the OC32 bits for both registers (OCyCON2<8>) and (OCxCON2<8>). Enable the even numbered module first to ensure the modules will start functioning in unison.
2. Clear the OCTRIG bit of the even module (OCyCON2), so the module will run in Synchronous mode.
3. Configure the desired output and Fault settings for OCy.
4. Force the output pin for OCx to the output state by clearing the OCTRIS bit.
5. If Trigger mode operation is required, configure the trigger options in OCx by using the OCTRIG (OCxCON2<7>), TRIGMODE (OCxCON1<3>) and SYNCSEL (OCxCON2<4:0>) bits.
6. Configure the desired Compare or PWM mode of operation (OCM<2:0>) for OCy first, then for OCx.

Depending on the output mode selected, the module holds the OCx pin in its default state and forces a transition to the opposite state when OCxR matches the timer. In Double Compare modes, OCx is forced back to its default state when a match with OCxRS occurs. The OCxIF interrupt flag is set after an OCxR match in Single Compare modes and after each OCxRS match in Double Compare modes.

Single-shot pulse events only occur once, but may be repeated by simply rewriting the value of the OCxCON1 register. Continuous pulse events continue indefinitely until terminated.

14.3 Pulse-Width Modulation (PWM) Mode

In PWM mode, the output compare module can be configured for edge-aligned or center-aligned pulse waveform generation. All PWM operations are double-buffered (buffer registers are internal to the module and are not mapped into SFR space).

To configure the output compare module for PWM operation:

1. Configure the OCx output for one of the available Peripheral Pin Select pins.
2. Calculate the desired duty cycles and load them into the OCxR register.
3. Calculate the desired period and load it into the OCxRS register.
4. Select the current OCx as the synchronization source by writing 0x1F to the SYNCSEL<4:0> bits (OCxCON2<4:0>) and '0' to the OCTRIG bit (OCxCON2<7>).
5. Select a clock source by writing to the OCTSEL<2:0> bits (OCxCON<12:10>).
6. Enable interrupts, if required, for the timer and output compare modules. The output compare interrupt is required for PWM Fault pin utilization.
7. Select the desired PWM mode in the OCM<2:0> bits (OCxCON1<2:0>).
8. Appropriate Fault inputs may be enabled by using the ENFLT<2:0> bits as described in Register 14-1.
9. If a timer is selected as a clock source, set the selected timer prescale value. The selected timer's prescaler output is used as the clock input for the OCx timer, and not the selected timer output.

Note: This peripheral contains input and output functions that may need to be configured by the Peripheral Pin Select. See **Section 10.4 "Peripheral Pin Select (PPS)"** for more information.

PIC24FJ256DA210 FAMILY

查询PIC24FJ256DA106供应商

FIGURE 14-2: OUTPUT COMPARE BLOCK DIAGRAM (DOUBLE-BUFFERED, 16-BIT PWM MODE)

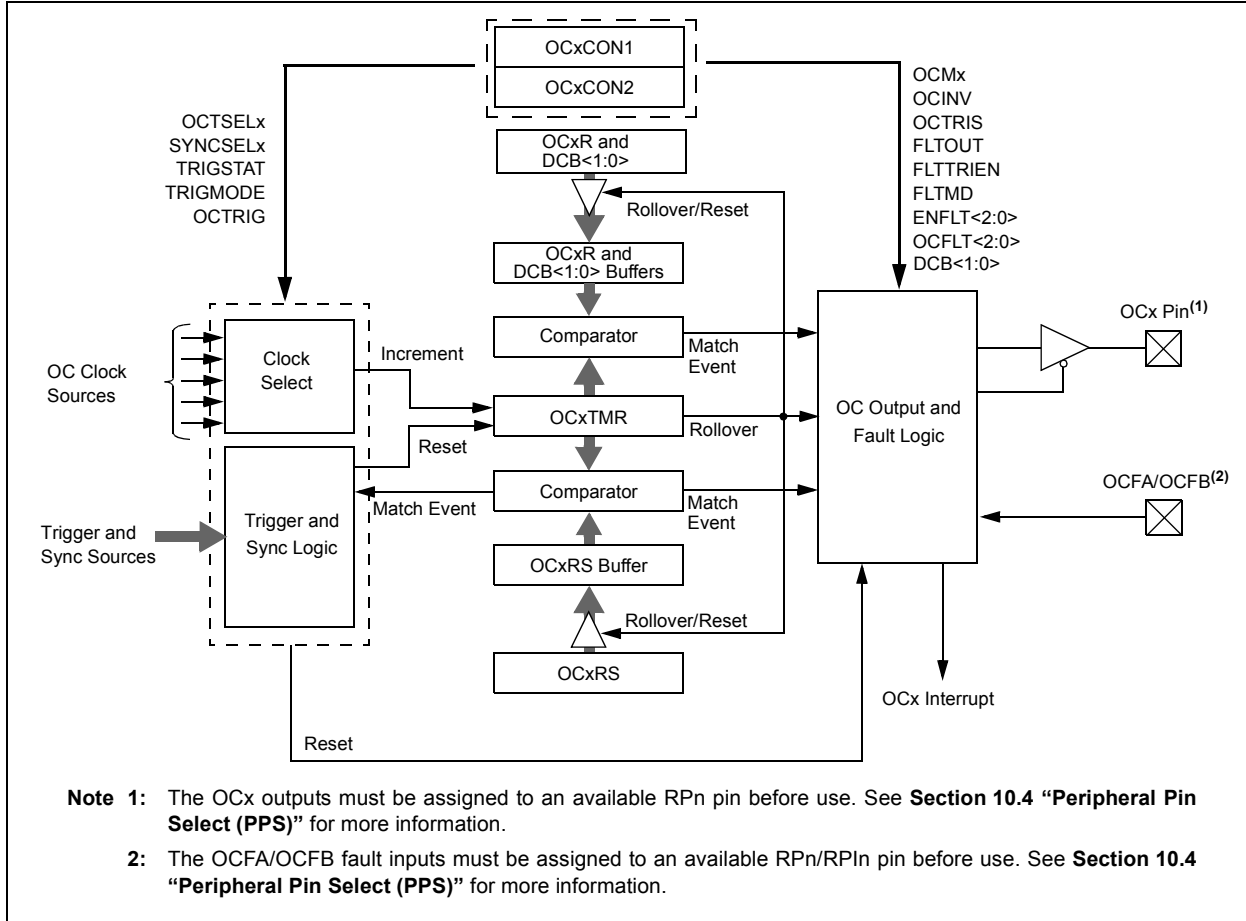

14.3.1 PWM PERIOD

The PWM period is specified by writing to PRy, the Timer Period register. The PWM period can be calculated using Equation 14-1.

EQUATION 14-1: CALCULATING THE PWM PERIOD⁽¹⁾

$$\text{PWM Period} = [(PRy) + 1 \cdot T_{CY} \cdot (\text{Timer Prescale Value})]$$

where:

$$\text{PWM Frequency} = 1/[\text{PWM Period}]$$

Note 1: Based on $T_{CY} = T_{OSC} \cdot 2$; Doze mode and PLL are disabled.

Note: A PRy value of N will produce a PWM period of N + 1 time base count cycles. For example, a value of 7 written into the PRy register will yield a period consisting of 8 time base cycles.

PIC24FJ256DA210 FAMILY

[查询PIC24FJ256DA106供应商](#)

14.3.2 PWM DUTY CYCLE

The PWM duty cycle is specified by writing to the OCxRS and OCxR registers. The OCxRS and OCxR registers can be written to at any time, but the duty cycle value is not latched until a match between PRy and TMRy occurs (i.e., the period is complete). This provides a double buffer for the PWM duty cycle and is essential for glitchless PWM operation.

Some important boundary parameters of the PWM duty cycle include:

- If OCxR, OCxRS, and PRy are all loaded with 0000h, the OCx pin will remain low (0% duty cycle).
- If OCxRS is greater than PRy, the pin will remain high (100% duty cycle).

See Example 14-1 for PWM mode timing details. Table 14-1 and Table 14-2 show example PWM frequencies and resolutions for a device operating at 4 MIPS and 10 MIPS, respectively.

EQUATION 14-2: CALCULATION FOR MAXIMUM PWM RESOLUTION⁽¹⁾

$$\text{Maximum PWM Resolution (bits)} = \frac{\log_{10} \left(\frac{F_{CY}}{F_{PWM} \cdot (\text{Timer Prescale Value})} \right)}{\log_{10}(2)} \text{ bits}$$

Note 1: Based on $F_{CY} = F_{OSC}/2$; Doze mode and PLL are disabled.

EXAMPLE 14-1: PWM PERIOD AND DUTY CYCLE CALCULATIONS⁽¹⁾

1. Find the Timer Period register value for a desired PWM frequency of 52.08 kHz, where $F_{OSC} = 8$ MHz with PLL (32 MHz device clock rate) and a Timer2 prescaler setting of 1:1.

$$T_{CY} = 2 * T_{OSC} = 62.5 \text{ ns}$$

$$\text{PWM Period} = 1/\text{PWM Frequency} = 1/52.08 \text{ kHz} = 19.2 \text{ ms}$$

$$\text{PWM Period} = (PR2 + 1) * T_{CY} * (\text{Timer2 Prescale Value})$$

$$19.2 \text{ ms} = (PR2 + 1) * 62.5 \text{ ns} * 1$$

$$PR2 = 306$$

2. Find the maximum resolution of the duty cycle that can be used with a 52.08 kHz frequency and a 32 MHz device clock rate:

$$\text{PWM Resolution} = \log_{10}(F_{CY}/F_{PWM})/\log_{10}(2) \text{ bits}$$

$$= (\log_{10}(16 \text{ MHz}/52.08 \text{ kHz})/\log_{10}(2)) \text{ bits}$$

$$= 8.3 \text{ bits}$$

Note 1: Based on $T_{CY} = 2 * T_{OSC}$; Doze mode and PLL are disabled.

TABLE 14-1: EXAMPLE PWM FREQUENCIES AND RESOLUTIONS AT 4 MIPS ($F_{CY} = 4$ MHz)⁽¹⁾

| PWM Frequency | 7.6 Hz | 61 Hz | 122 Hz | 977 Hz | 3.9 kHz | 31.3 kHz | 125 kHz |
|-----------------------|--------|-------|--------|--------|---------|----------|---------|
| Timer Prescaler Ratio | 8 | 1 | 1 | 1 | 1 | 1 | 1 |
| Period Register Value | FFFFh | FFFFh | 7FFFh | 0FFFh | 03FFh | 007Fh | 001Fh |
| Resolution (bits) | 16 | 16 | 15 | 12 | 10 | 7 | 5 |

Note 1: Based on $F_{CY} = F_{OSC}/2$; Doze mode and PLL are disabled.

TABLE 14-2: EXAMPLE PWM FREQUENCIES AND RESOLUTIONS AT 16 MIPS ($F_{CY} = 16$ MHz)⁽¹⁾

| PWM Frequency | 30.5 Hz | 244 Hz | 488 Hz | 3.9 kHz | 15.6 kHz | 125 kHz | 500 kHz |
|-----------------------|---------|--------|--------|---------|----------|---------|---------|
| Timer Prescaler Ratio | 8 | 1 | 1 | 1 | 1 | 1 | 1 |
| Period Register Value | FFFFh | FFFFh | 7FFFh | 0FFFh | 03FFh | 007Fh | 001Fh |
| Resolution (bits) | 16 | 16 | 15 | 12 | 10 | 7 | 5 |

Note 1: Based on $F_{CY} = F_{OSC}/2$; Doze mode and PLL are disabled.

PIC24FJ256DA210 FAMILY

查询PIC24FJ256DA106供应商

REGISTER 14-1: OCxCON1: OUTPUT COMPARE x CONTROL REGISTER 1

| | | | | | | | |
|--------|-----|--------|---------|---------|---------|-----------------------|-----------------------|
| U-0 | U-0 | R/W-0 | R/W-0 | R/W-0 | R/W-0 | R/W-0 | R/W-0 |
| — | — | OCSIDL | OCTSEL2 | OCTSEL1 | OCTSEL0 | ENFLT2 ⁽²⁾ | ENFLT1 ⁽²⁾ |
| bit 15 | | | | | | bit 8 | |

| | | | | | | | |
|-----------------------|-----------------------|-----------------------|-----------------------|----------|---------------------|---------------------|---------------------|
| R/W-0 | R/W-0, HSC | R/W-0, HSC | R/W-0, HSC | R/W-0 | R/W-0 | R/W-0 | R/W-0 |
| ENFLT0 ⁽²⁾ | OCFLT2 ⁽²⁾ | OCFLT1 ⁽²⁾ | OCFLT0 ⁽²⁾ | TRIGMODE | OCM2 ⁽¹⁾ | OCM1 ⁽¹⁾ | OCM0 ⁽¹⁾ |
| bit 7 | | | | | | bit 0 | |

| | | | | | | | |
|-------------------|---------------------------------------|------------------------------------|--------------------|--|--|--|--|
| Legend: | HSC = Hardware Settable/Clearable bit | | | | | | |
| R = Readable bit | W = Writable bit | U = Unimplemented bit, read as '0' | | | | | |
| -n = Value at POR | '1' = Bit is set | '0' = Bit is cleared | x = Bit is unknown | | | | |

- bit 15-14 **Unimplemented:** Read as '0'
- bit 13 **OCSIDL:** Stop Output Compare x in Idle Mode Control bit
 1 = Output Compare x halts in CPU Idle mode
 0 = Output Compare x continues to operate in CPU Idle mode
- bit 12-10 **OCTSEL<2:0>:** Output Compare x Timer Select bits
 111 = Peripheral clock (FCY)
 110 = Reserved
 101 = Reserved
 100 = Timer1 clock (only synchronous clock is supported)
 011 = Timer5 clock
 010 = Timer4 clock
 001 = Timer3 clock
 000 = Timer2 clock
- bit 9 **ENFLT2:** Fault Input 2 Enable bit⁽²⁾
 1 = Fault 2 (Comparator 1/2/3 out) is enabled⁽³⁾
 0 = Fault 2 is disabled
- bit 8 **ENFLT1:** Fault Input 1 Enable bit⁽²⁾
 1 = Fault 1 (OCFB pin) is enabled⁽⁴⁾
 0 = Fault 1 is disabled
- bit 7 **ENFLT0:** Fault Input 0 Enable bit⁽²⁾
 1 = Fault 0 (OCFA pin) is enabled⁽⁴⁾
 0 = Fault 0 is disabled
- bit 6 **OCFLT2:** PWM Fault 2 (Comparator 1/2/3) Condition Status bit^(2,3)
 1 = PWM Fault 2 has occurred
 0 = No PWM Fault 2 has occurred
- bit 5 **OCFLT1:** PWM Fault 1 (OCFB pin) Condition Status bit^(2,4)
 1 = PWM Fault 1 has occurred
 0 = No PWM Fault 1 has occurred
- bit 4 **OCFLT0:** PWM Fault 0 (OCFA pin) Condition Status bit^(2,4)
 1 = PWM Fault 0 has occurred
 0 = No PWM Fault 0 has occurred

- Note 1:** The OCx output must also be configured to an available RPN pin. For more information, see **Section 10.4 "Peripheral Pin Select (PPS)"**.
- 2:** The Fault input enable and Fault status bits are valid when OCM<2:0> = 111 or 110.
- 3:** The Comparator 1 output controls the OC1-OC3 channels; Comparator 2 output controls the OC4-OC6 channels; Comparator 3 output controls the OC7-OC9 channels.
- 4:** The OCFA/OCFB Fault input must also be configured to an available RPN/RPIn pin. For more information, see **Section 10.4 "Peripheral Pin Select (PPS)"**.

PIC24FJ256DA210 FAMILY

[查询PIC24FJ256DA106供应商](#)

REGISTER 14-1: OCxCON1: OUTPUT COMPARE x CONTROL REGISTER 1 (CONTINUED)

- bit 3 **TRIGMODE:** Trigger Status Mode Select bit
1 = TRIGSTAT (OCxCON2<6>) is cleared when OCxRS = OCxTMR or in software
0 = TRIGSTAT is only cleared by software
- bit 2-0 **OCM<2:0>:** Output Compare x Mode Select bits⁽¹⁾
111 = Center-Aligned PWM mode on OCx⁽²⁾
110 = Edge-Aligned PWM Mode on OCx⁽²⁾
101 = Double Compare Continuous Pulse mode: Initialize the OCx pin low, the toggle OCx state continuously on alternate matches of OCxR and OCxRS
100 = Double Compare Single-Shot mode: Initialize the OCx pin low, toggle the OCx state on matches of OCxR and OCxRS for one cycle
011 = Single Compare Continuous Pulse mode: Compare events continuously toggle the OCx pin
010 = Single Compare Single-Shot mode: Initialize OCx pin high, compare event forces the OCx pin low
001 = Single Compare Single-Shot mode: Initialize OCx pin low, compare event forces the OCx pin high
000 = Output compare channel is disabled

- Note 1:** The OCx output must also be configured to an available RPN pin. For more information, see **Section 10.4 “Peripheral Pin Select (PPS)”**.
- 2:** The Fault input enable and Fault status bits are valid when OCM<2:0> = 111 or 110.
- 3:** The Comparator 1 output controls the OC1-OC3 channels; Comparator 2 output controls the OC4-OC6 channels; Comparator 3 output controls the OC7-OC9 channels.
- 4:** The OCFA/OCFB Fault input must also be configured to an available RPN/RPIN pin. For more information, see **Section 10.4 “Peripheral Pin Select (PPS)”**.

PIC24FJ256DA210 FAMILY

查询PIC24FJ256DA106供应商

REGISTER 14-2: OCxCON2: OUTPUT COMPARE x CONTROL REGISTER 2

| | | | | | | | |
|--------|--------|----------|-------|-----|---------------------|---------------------|-------|
| R/W-0 | R/W-0 | R/W-0 | R/W-0 | U-0 | R/W-0 | R/W-0 | R/W-0 |
| FLTMD | FLTOUT | FLTTRIEN | OCINV | — | DCB1 ⁽³⁾ | DCB0 ⁽³⁾ | OC32 |
| bit 15 | | | | | | | bit 8 |

| | | | | | | | |
|--------|----------|--------|----------|----------|----------|----------|----------|
| R/W-0 | R/W-0 HS | R/W-0 | R/W-0 | R/W-1 | R/W-1 | R/W-0 | R/W-0 |
| OCTRIG | TRIGSTAT | OCTRIS | SYNCSEL4 | SYNCSEL3 | SYNCSEL2 | SYNCSEL1 | SYNCSEL0 |
| bit 7 | | | | | | | bit 0 |

| | | | |
|-------------------|----------------------------|------------------------------------|--------------------|
| Legend: | HS = Hardware Settable bit | | |
| R = Readable bit | W = Writable bit | U = Unimplemented bit, read as '0' | |
| -n = Value at POR | '1' = Bit is set | '0' = Bit is cleared | x = Bit is unknown |

- bit 15 **FLTMD:** Fault Mode Select bit
 1 = Fault mode is maintained until the Fault source is removed and the corresponding OCFLT0 bit is cleared in software
 0 = Fault mode is maintained until the Fault source is removed and a new PWM period starts
- bit 14 **FLTOUT:** Fault Out bit
 1 = PWM output is driven high on a Fault
 0 = PWM output is driven low on a Fault
- bit 13 **FLTTRIEN:** Fault Output State Select bit
 1 = Pin is forced to an output on a Fault condition
 0 = Pin I/O condition is unaffected by a Fault
- bit 12 **OCINV:** OCMP Invert bit
 1 = OCx output is inverted
 0 = OCx output is not inverted
- bit 11 **Unimplemented:** Read as '0'
- bit 10-9 **DCB<11:0>:** PWM Duty Cycle Least Significant bits⁽³⁾
 11 = Delay OCx falling edge by $\frac{3}{4}$ of the instruction cycle
 10 = Delay OCx falling edge by $\frac{1}{2}$ of the instruction cycle
 01 = Delay OCx falling edge by $\frac{1}{4}$ of the instruction cycle
 00 = OCx falling edge occurs at the start of the instruction cycle
- bit 8 **OC32:** Cascade Two OC Modules Enable bit (32-bit operation)
 1 = Cascade module operation enabled
 0 = Cascade module operation disabled
- bit 7 **OCTRIG:** OCx Trigger/Sync Select bit
 1 = Trigger OCx from the source designated by the SYNCSELx bits
 0 = Synchronize OCx with the source designated by the SYNCSELx bits
- bit 6 **TRIGSTAT:** Timer Trigger Status bit
 1 = Timer source has been triggered and is running
 0 = Timer source has not been triggered and is being held clear
- bit 5 **OCTRIS:** OCx Output Pin Direction Select bit
 1 = OCx pin is tri-stated
 0 = Output compare peripheral x is connected to an OCx pin

- Note 1:** Never use an OC module as its own trigger source, either by selecting this mode or another equivalent SYNCSEL setting.
- 2:** Use these inputs as trigger sources only and never as sync sources.
- 3:** The DCB<1:0> bits are double-buffered in the PWM modes only (OCM<2:0> (OCxCON1<2:0>) = 111, 110).

PIC24FJ256DA210 FAMILY

[查询PIC24FJ256DA106供应商](#)

REGISTER 14-2: OCxCON2: OUTPUT COMPARE x CONTROL REGISTER 2 (CONTINUED)

bit 4-0 **SYNCSEL<4:0>**: Trigger/Synchronization Source Selection bits

11111 = This OC module⁽¹⁾
11110 = Input Capture 9⁽²⁾
11101 = Input Capture 6⁽²⁾
11100 = CTMU⁽²⁾
11011 = A/D⁽²⁾
11010 = Comparator 3⁽²⁾
11001 = Comparator 2⁽²⁾
11000 = Comparator 1⁽²⁾
10111 = Input Capture 4⁽²⁾
10110 = Input Capture 3⁽²⁾
10101 = Input Capture 2⁽²⁾
10100 = Input Capture 1⁽²⁾
10011 = Input Capture 8⁽²⁾
10010 = Input Capture 7⁽²⁾
1000x = Reserved
01111 = Timer5
01110 = Timer4
01101 = Timer3
01100 = Timer2
01011 = Timer1
01010 = Input Capture 5⁽²⁾
01001 = Output Compare 9⁽¹⁾
01000 = Output Compare 8⁽¹⁾
00111 = Output Compare 7⁽¹⁾
00110 = Output Compare 6⁽¹⁾
00101 = Output Compare 5⁽¹⁾
00100 = Output Compare 4⁽¹⁾
00011 = Output Compare 3⁽¹⁾
00010 = Output Compare 2⁽¹⁾
00001 = Output Compare 1⁽¹⁾
00000 = Not synchronized to any other module

- Note 1:** Never use an OC module as its own trigger source, either by selecting this mode or another equivalent SYNCSEL setting.
- 2:** Use these inputs as trigger sources only and never as sync sources.
- 3:** The DCB<1:0> bits are double-buffered in the PWM modes only (OCM<2:0> (OCxCON1<2:0>) = 111, 110).

PIC24FJ256DA210 FAMILY

[查询PIC24FJ256DA106供应商](#)

NOTES:

PIC24FJ256DA210 FAMILY

[查询PIC24FJ256DA106供应商](#)

15.0 SERIAL PERIPHERAL INTERFACE (SPI)

Note: This data sheet summarizes the features of this group of PIC24F devices. It is not intended to be a comprehensive reference source. For more information, refer to the “PIC24F Family Reference Manual”, Section 23. “Serial Peripheral Interface (SPI)” (DS39699). The information in this data sheet supersedes the information in the FRM.

The Serial Peripheral Interface (SPI) module is a synchronous serial interface useful for communicating with other peripheral or microcontroller devices. These peripheral devices may be serial EEPROMs, shift registers, display drivers, A/D Converters, etc. The SPI module is compatible with the SPI and SIOP Motorola® interfaces. All devices of the PIC24FJ256DA210 family include three SPI modules.

The module supports operation in two buffer modes. In Standard mode, data is shifted through a single serial buffer. In Enhanced Buffer mode, data is shifted through an 8-level FIFO buffer.

Note: Do not perform read-modify-write operations (such as bit-oriented instructions) on the SPIxBUF register in either Standard or Enhanced Buffer mode.

The module also supports a basic framed SPI protocol while operating in either Master or Slave mode. A total of four framed SPI configurations are supported.

The SPI serial interface consists of four pins:

- SDIx: Serial Data Input
- SDOx: Serial Data Output
- SCKx: Shift Clock Input or Output
- $\overline{\text{SSx}}$: Active-Low Slave Select or Frame Synchronization I/O Pulse

The SPI module can be configured to operate using 2, 3 or 4 pins. In the 3-pin mode, $\overline{\text{SSx}}$ is not used. In the 2-pin mode, both SDOx and $\overline{\text{SSx}}$ are not used.

Block diagrams of the module in Standard and Enhanced modes are shown in Figure 15-1 and Figure 15-2.

Note: In this section, the SPI modules are referred to together as SPIx or separately as SPI1, SPI2 or SPI3. Special Function Registers will follow a similar notation. For example, SPIxCON1 and SPIxCON2 refer to the control registers for any of the 3 SPI modules.

PIC24FJ256DA210 FAMILY

[查询PIC24FJ256DA106供应商](#)

To set up the SPI module for the Standard Master mode of operation:

1. If using interrupts:
 - a) Clear the SPIxIF bit in the respective IFS register.
 - b) Set the SPIxIE bit in the respective IEC register.
 - c) Write the SPIxIP bits in the respective IPC register to set the interrupt priority.
2. Write the desired settings to the SPIxCON1 and SPIxCON2 registers with MSTEN (SPIxCON1<5>) = 1.
3. Clear the SPIROV bit (SPIxSTAT<6>).
4. Enable SPI operation by setting the SPIEN bit (SPIxSTAT<15>).
5. Write the data to be transmitted to the SPIxBUF register. Transmission (and reception) will start as soon as data is written to the SPIxBUF register.

To set up the SPI module for the Standard Slave mode of operation:

1. Clear the SPIxBUF register.
2. If using interrupts:
 - a) Clear the SPIxIF bit in the respective IFS register.
 - b) Set the SPIxIE bit in the respective IEC register.
 - c) Write the SPIxIP bits in the respective IPC register to set the interrupt priority.
3. Write the desired settings to the SPIxCON1 and SPIxCON2 registers with MSTEN (SPIxCON1<5>) = 0.
4. Clear the SMP bit.
5. If the CKE bit (SPIxCON1<8>) is set, then the SSx pin must be set to enable the SSx pin.
6. Clear the SPIROV bit (SPIxSTAT<6>).
7. Enable SPI operation by setting the SPIEN bit (SPIxSTAT<15>).

FIGURE 15-1: SPIx MODULE BLOCK DIAGRAM (STANDARD MODE)

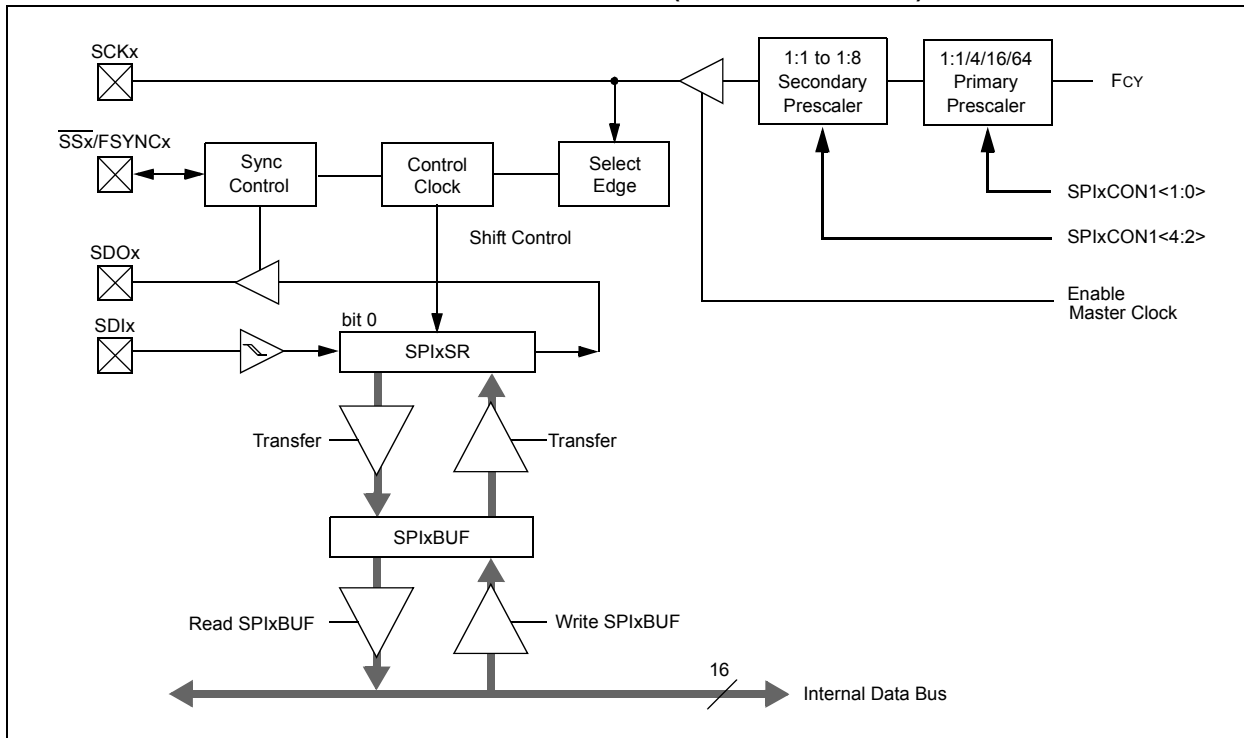

PIC24FJ256DA210 FAMILY

[查询PIC24FJ256DA106供应商](#)

To set up the SPI module for the Enhanced Buffer Master mode of operation:

1. If using interrupts:
 - a) Clear the SPIxIF bit in the respective IFS register.
 - b) Set the SPIxIE bit in the respective IEC register.
 - c) Write the SPIxIP bits in the respective IPC register.
2. Write the desired settings to the SPIxCON1 and SPIxCON2 registers with MSTEN (SPIxCON1<5>) = 1.
3. Clear the SPIROV bit (SPIxSTAT<6>).
4. Select Enhanced Buffer mode by setting the SPIBEN bit (SPIxCON2<0>).
5. Enable SPI operation by setting the SPIEN bit (SPIxSTAT<15>).
6. Write the data to be transmitted to the SPIxBUF register. Transmission (and reception) will start as soon as data is written to the SPIxBUF register.

To set up the SPI module for the Enhanced Buffer Slave mode of operation:

1. Clear the SPIxBUF register.
2. If using interrupts:
 - a) Clear the SPIxIF bit in the respective IFS register.
 - b) Set the SPIxIE bit in the respective IEC register.
 - c) Write the SPIxIP bits in the respective IPC register to set the interrupt priority.
3. Write the desired settings to the SPIxCON1 and SPIxCON2 registers with MSTEN (SPIxCON1<5>) = 0.
4. Clear the SMP bit.
5. If the CKE bit is set, then the SSx pin must be set, thus enabling the SSx pin.
6. Clear the SPIROV bit (SPIxSTAT<6>).
7. Select Enhanced Buffer mode by setting the SPIBEN bit (SPIxCON2<0>).
8. Enable SPI operation by setting the SPIEN bit (SPIxSTAT<15>).

FIGURE 15-2: SPIx MODULE BLOCK DIAGRAM (ENHANCED MODE)

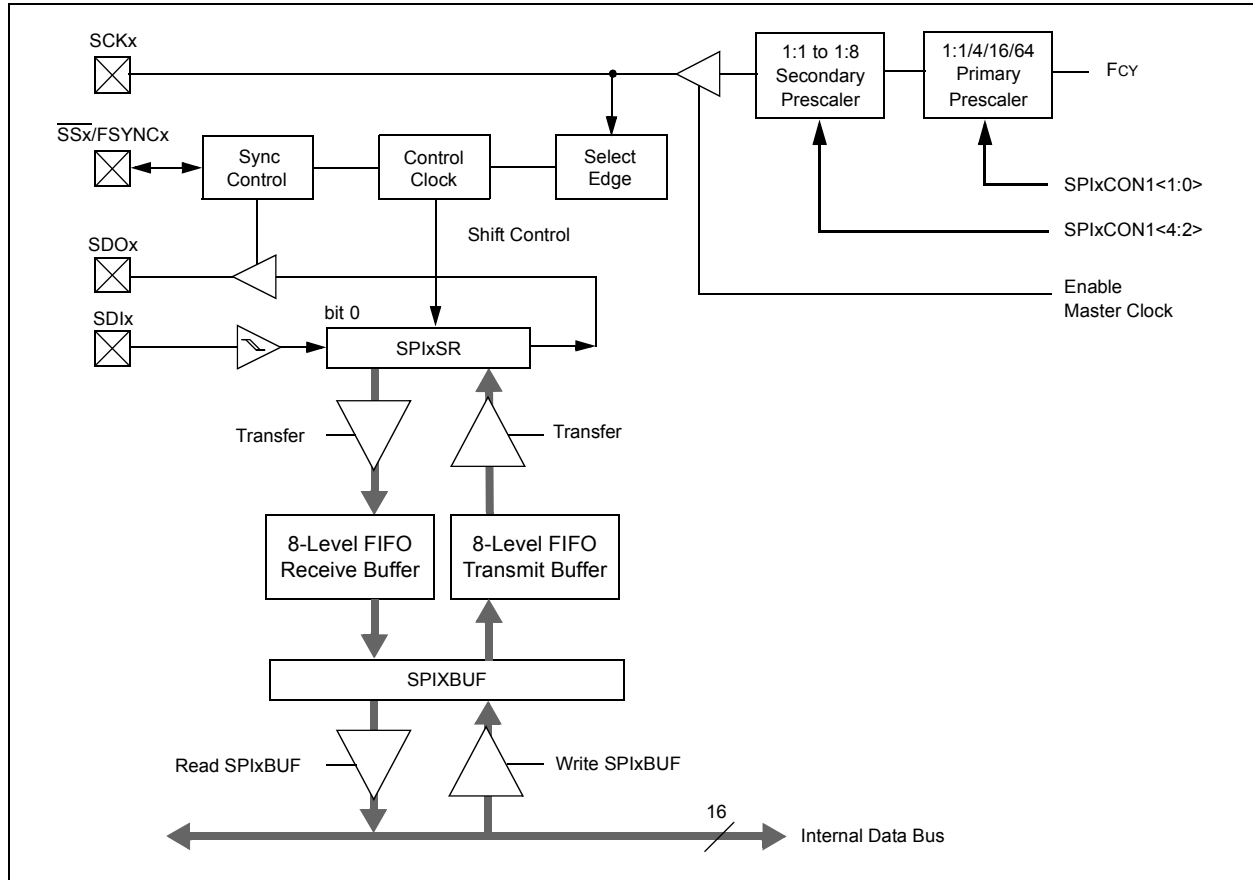

PIC24FJ256DA210 FAMILY

[查询PIC24FJ256DA106供应商](#)

REGISTER 15-1: SPIxSTAT: SPIx STATUS AND CONTROL REGISTER

| | | | | | | | |
|----------------------|-----|---------|-----|-----|----------|----------|----------|
| R/W-0 | U-0 | R/W-0 | U-0 | U-0 | R-0, HSC | R-0, HSC | R-0, HSC |
| SPIEN ⁽¹⁾ | — | SPISIDL | — | — | SPIBEC2 | SPIBEC1 | SPIBEC0 |
| bit 15 | | | | | | | bit 8 |

| | | | | | | | |
|----------|-----------|----------|--------|--------|--------|----------|----------|
| R-0, HSC | R/C-0, HS | R-0, HSC | R/W-0 | R/W-0 | R/W-0 | R-0, HSC | R-0, HSC |
| SRMPT | SPIROV | SRXMPT | SISEL2 | SISEL1 | SISEL0 | SPITBF | SPIRBF |
| bit 7 | | | | | | | bit 0 |

| | | |
|---------------------------------------|-------------------|------------------------------------|
| Legend: | C = Clearable bit | HS = Hardware Settable bit |
| R = Readable bit | W = Writable bit | U = Unimplemented bit, read as '0' |
| -n = Value at POR | '1' = Bit is set | '0' = Bit is cleared |
| HSC = Hardware Settable/Clearable bit | | x = Bit is unknown |

- bit 15 **SPIEN:** SPIx Enable bit⁽¹⁾
 1 = Enables module and configures SCKx, SDOx, SDIx and \overline{SSx} as serial port pins
 0 = Disables module
- bit 14 **Unimplemented:** Read as '0'
- bit 13 **SPISIDL:** Stop in Idle Mode bit
 1 = Discontinue module operation when device enters Idle mode
 0 = Continue module operation in Idle mode
- bit 12-11 **Unimplemented:** Read as '0'
- bit 10-8 **SPIBEC<2:0>:** SPIx Buffer Element Count bits (valid in Enhanced Buffer mode)
Master mode:
 Number of SPI transfers pending.
Slave mode:
 Number of SPI transfers unread.
- bit 7 **SRMPT:** Shift Register (SPIxSR) Empty bit (valid in Enhanced Buffer mode)
 1 = SPIx Shift register is empty and ready to send or receive
 0 = SPIx Shift register is not empty
- bit 6 **SPIROV:** Receive Overflow Flag bit
 1 = A new byte/word is completely received and discarded
 (The user software has not read the previous data in the SPIxBUF register.)
 0 = No overflow has occurred
- bit 5 **SRXMPT:** Receive FIFO Empty bit (valid in Enhanced Buffer mode)
 1 = Receive FIFO is empty
 0 = Receive FIFO is not empty
- bit 4-2 **SISEL<2:0>:** SPIx Buffer Interrupt Mode bits (valid in Enhanced Buffer mode)
 111 = Interrupt when the SPIx transmit buffer is full (SPITBF bit is set)
 110 = Interrupt when the last bit is shifted into SPIxSR; as a result, the TX FIFO is empty
 101 = Interrupt when the last bit is shifted out of SPIxSR; now the transmit is complete
 100 = Interrupt when one data is shifted into the SPIxSR; as a result, the TX FIFO has one open spot
 011 = Interrupt when the SPIx receive buffer is full (SPIRBF bit set)
 010 = Interrupt when the SPIx receive buffer is 3/4 or more full
 001 = Interrupt when data is available in the receive buffer (SRMPT bit is set)
 000 = Interrupt when the last data in the receive buffer is read; as a result, the buffer is empty (SRXMPT bit set)

Note 1: If SPIEN = 1, these functions must be assigned to available RPN/RPI pins before use. See **Section 10.4 "Peripheral Pin Select (PPS)"** for more information.

PIC24FJ256DA210 FAMILY

[查询PIC24FJ256DA106供应商](#)

REGISTER 15-1: SPIxSTAT: SPIx STATUS AND CONTROL REGISTER (CONTINUED)

- bit 1 **SPITBF:** SPIx Transmit Buffer Full Status bit
1 = Transmit not yet started, SPIxTXB is full
0 = Transmit started, SPIxTXB is empty
In Standard Buffer mode:
Automatically set in hardware when the CPU writes to the SPIxBUF location, loading SPIxTXB.
Automatically cleared in hardware when the SPIx module transfers data from SPIxTXB to SPIxSR.
In Enhanced Buffer mode:
Automatically set in hardware when the CPU writes to the SPIxBUF location, loading the last available buffer location.
Automatically cleared in hardware when a buffer location is available for a CPU write.
- bit 0 **SPIRBF:** SPIx Receive Buffer Full Status bit
1 = Receive complete, SPIxRXB is full
0 = Receive is not complete, SPIxRXB is empty
In Standard Buffer mode:
Automatically set in hardware when SPIx transfers data from SPIxSR to SPIxRXB.
Automatically cleared in hardware when the core reads the SPIxBUF location, reading SPIxRXB.
In Enhanced Buffer mode:
Automatically set in hardware when SPIx transfers data from the SPIxSR to the buffer, filling the last unread buffer location.
Automatically cleared in hardware when a buffer location is available for a transfer from SPIxSR.

Note 1: If SPIEN = 1, these functions must be assigned to available RPN/RPIn pins before use. See **Section 10.4 “Peripheral Pin Select (PPS)”** for more information.

PIC24FJ256DA210 FAMILY

[查询PIC24FJ256DA106供应商](#)

REGISTER 15-2: SPIXCON1: SPIx CONTROL REGISTER 1

| | | | | | | | |
|--------|-----|-----|-----------------------|-----------------------|--------|-------|--------------------|
| U-0 | U-0 | U-0 | R/W-0 | R/W-0 | R/W-0 | R/W-0 | R/W-0 |
| — | — | — | DISSCK ⁽¹⁾ | DISSDO ⁽²⁾ | MODE16 | SMP | CKE ⁽³⁾ |
| bit 15 | | | | | | | bit 8 |

| | | | | | | | |
|---------------------|-------|-------|-------|-------|-------|-------|-------|
| R/W-0 | R/W-0 | R/W-0 | R/W-0 | R/W-0 | R/W-0 | R/W-0 | R/W-0 |
| SSEN ⁽⁴⁾ | CKP | MSTEN | SPRE2 | SPRE1 | SPRE0 | PPRE1 | PPRE0 |
| bit 7 | | | | | | | bit 0 |

Legend:

R = Readable bit

W = Writable bit

U = Unimplemented bit, read as '0'

-n = Value at POR

'1' = Bit is set

'0' = Bit is cleared

x = Bit is unknown

bit 15-13 **Unimplemented:** Read as '0'

bit 12 **DISSCK:** Disable SCKx Pin bit (SPI Master modes only)⁽¹⁾

1 = Internal SPI clock is disabled; pin functions as I/O

0 = Internal SPI clock is enabled

bit 11 **DISSDO:** Disable SDOx Pin bit⁽²⁾

1 = SDOx pin is not used by the module; pin functions as I/O

0 = SDOx pin is controlled by the module

bit 10 **MODE16:** Word/Byte Communication Select bit

1 = Communication is word-wide (16 bits)

0 = Communication is byte-wide (8 bits)

bit 9 **SMP:** SPIx Data Input Sample Phase bit

Master mode:

1 = Input data sampled at the end of data output time

0 = Input data sampled at the middle of data output time

Slave mode:

SMP must be cleared when SPIx is used in Slave mode.

bit 8 **CKE:** SPIx Clock Edge Select bit⁽³⁾

1 = Serial output data changes on transition from active clock state to Idle clock state (see bit 6)

0 = Serial output data changes on transition from Idle clock state to active clock state (see bit 6)

bit 7 **SSEN:** Slave Select Enable (Slave mode) bit⁽⁴⁾

1 = \overline{SSx} pin is used for Slave mode

0 = \overline{SSx} pin is not used by the module; pin is controlled by the port function

bit 6 **CKP:** Clock Polarity Select bit

1 = Idle state for the clock is a high level; active state is a low level

0 = Idle state for the clock is a low level; active state is a high level

bit 5 **MSTEN:** Master Mode Enable bit

1 = Master mode

0 = Slave mode

Note 1: If DISSCK = 0, SCKx must be configured to an available RPn pin. See **Section 10.4 “Peripheral Pin Select (PPS)”** for more information.

Note 2: If DISSDO = 0, SDOx must be configured to an available RPn pin. See **Section 10.4 “Peripheral Pin Select (PPS)”** for more information.

Note 3: The CKE bit is not used in the Framed SPI modes. The user should program this bit to '0' for the Framed SPI modes (FRMEN = 1).

Note 4: If SSEN = 1, \overline{SSx} must be configured to an available RPn/PRIn pin. See **Section 10.4 “Peripheral Pin Select (PPS)”** for more information.

PIC24FJ256DA210 FAMILY

[查询PIC24FJ256DA106供应商](#)

REGISTER 15-2: SPIXCON1: SPIx CONTROL REGISTER 1 (CONTINUED)

bit 4-2 **SPRE<2:0>**: Secondary Prescale bits (Master mode)

111 = Secondary prescale 1:1

110 = Secondary prescale 2:1

.

.

.

000 = Secondary prescale 8:1

bit 1-0 **PPRE<1:0>**: Primary Prescale bits (Master mode)

11 = Primary prescale 1:1

10 = Primary prescale 4:1

01 = Primary prescale 16:1

00 = Primary prescale 64:1

- Note 1:** If DISSCK = 0, SCKx must be configured to an available RPn pin. See **Section 10.4 “Peripheral Pin Select (PPS)”** for more information.
- 2:** If DISSDO = 0, SDOx must be configured to an available RPn pin. See **Section 10.4 “Peripheral Pin Select (PPS)”** for more information.
- 3:** The CKE bit is not used in the Framed SPI modes. The user should program this bit to '0' for the Framed SPI modes (FRMEN = 1).
- 4:** If SSEN = 1, \overline{SSx} must be configured to an available RPn/PRIn pin. See **Section 10.4 “Peripheral Pin Select (PPS)”** for more information.

PIC24FJ256DA210 FAMILY

[查询PIC24FJ256DA106供应商](#)

REGISTER 15-3: SPIxCON2: SPIx CONTROL REGISTER 2

| | | | | | | | |
|--------|--------|---------|-----|-----|-----|-----|-------|
| R/W-0 | R/W-0 | R/W-0 | U-0 | U-0 | U-0 | U-0 | U-0 |
| FRMEN | SPIFSD | SPIFPOL | — | — | — | — | — |
| bit 15 | | | | | | | bit 8 |

| | | | | | | | |
|-------|-----|-----|-----|-----|-----|-------|--------|
| U-0 | U-0 | U-0 | U-0 | U-0 | U-0 | R/W-0 | R/W-0 |
| — | — | — | — | — | — | SPIFE | SPIBEN |
| bit 7 | | | | | | bit 0 | |

Legend:

R = Readable bit

W = Writable bit

U = Unimplemented bit, read as '0'

-n = Value at POR

'1' = Bit is set

'0' = Bit is cleared

x = Bit is unknown

- bit 15 **FRMEN:** Framed SPIx Support bit
 1 = Framed SPIx support is enabled
 0 = Framed SPIx support is disabled
- bit 14 **SPIFSD:** Frame Sync Pulse Direction Control on \overline{SSx} Pin bit
 1 = Frame sync pulse input (slave)
 0 = Frame sync pulse output (master)
- bit 13 **SPIFPOL:** Frame Sync Pulse Polarity bit (Frame mode only)
 1 = Frame sync pulse is active-high
 0 = Frame sync pulse is active-low
- bit 12-2 **Unimplemented:** Read as '0'
- bit 1 **SPIFE:** Frame Sync Pulse Edge Select bit
 1 = Frame sync pulse coincides with the first bit clock
 0 = Frame sync pulse precedes the first bit clock
- bit 0 **SPIBEN:** Enhanced Buffer Enable bit
 1 = Enhanced buffer is enabled
 0 = Enhanced buffer is disabled (Legacy mode)

PIC24FJ256DA210 FAMILY

[查询PIC24FJ256DA106供应商](#)

FIGURE 15-3: SPI MASTER/S�AVE CONNECTION (STANDARD MODE)

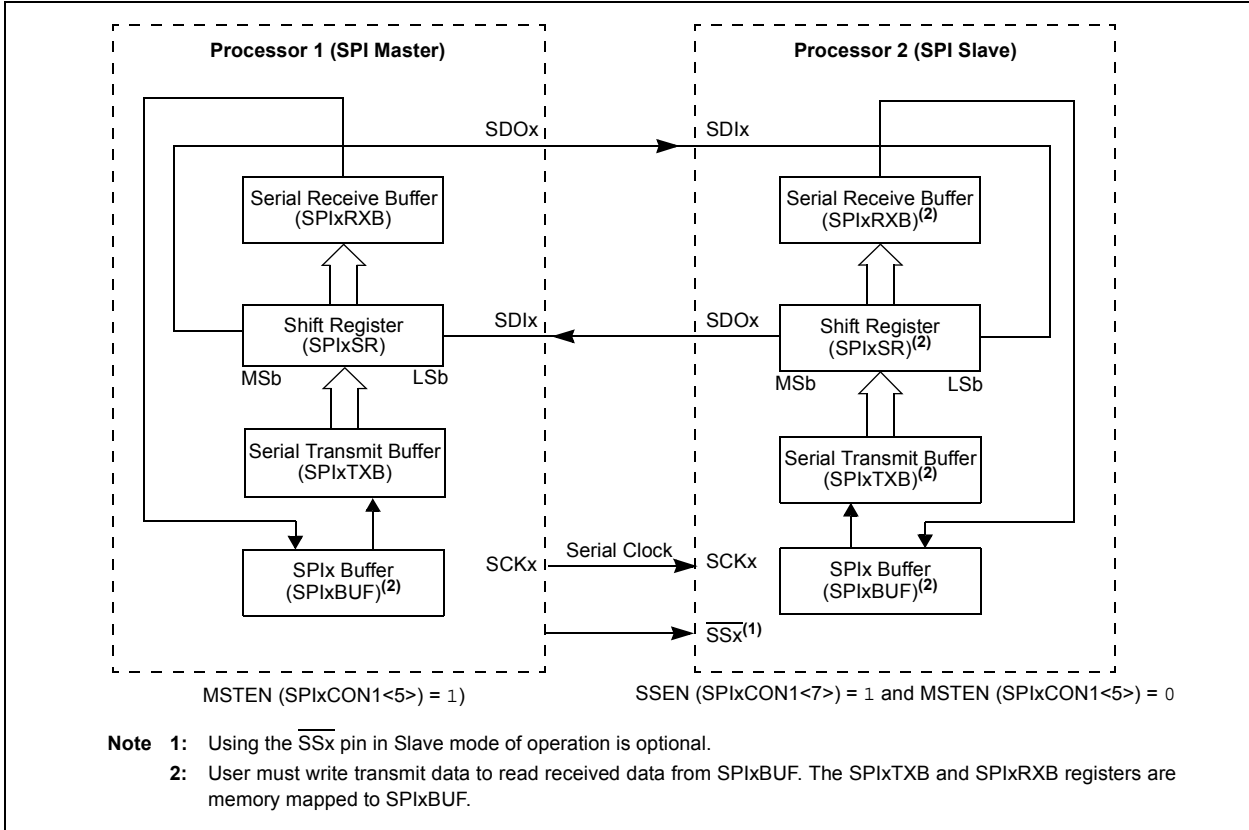
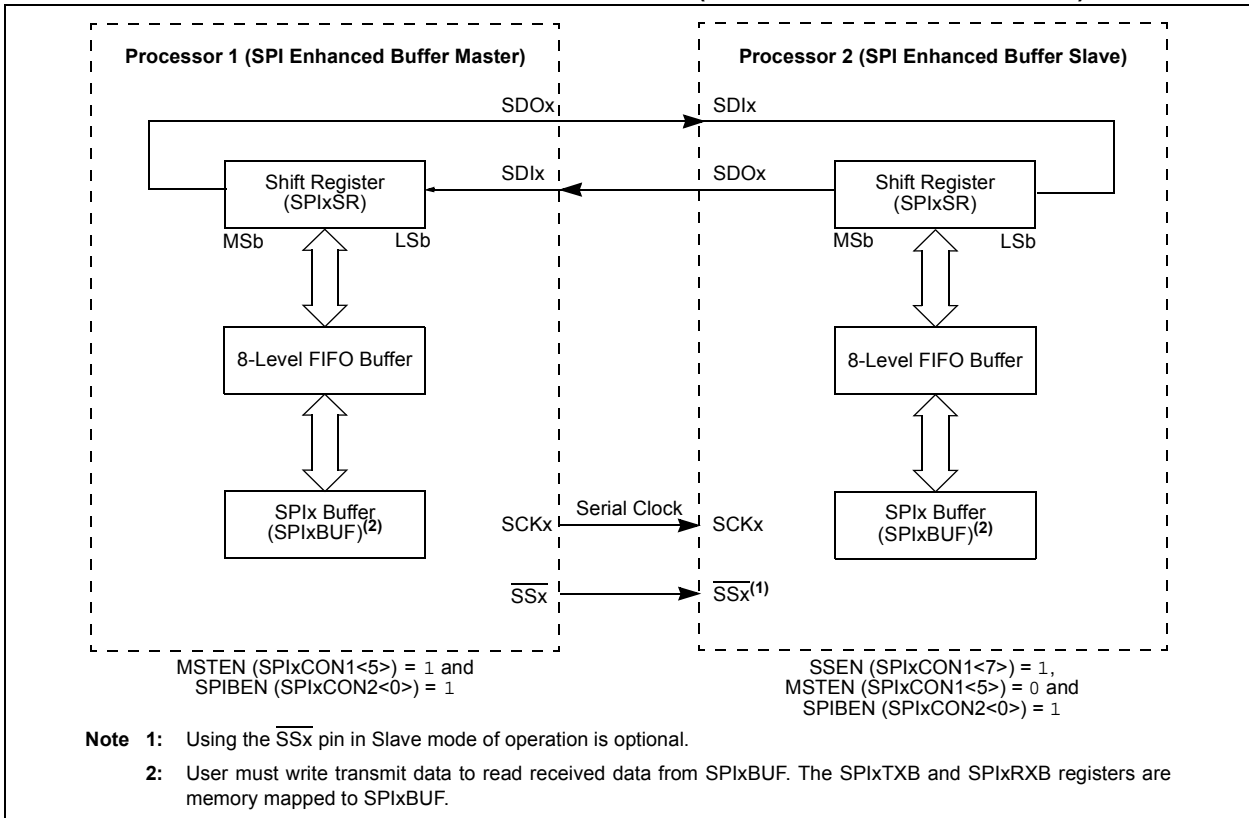

FIGURE 15-4: SPI MASTER/S�AVE CONNECTION (ENHANCED BUFFER MODES)



PIC24FJ256DA210 FAMILY

[查询PIC24FJ256DA106供应商](#)

FIGURE 15-5: SPI MASTER, FRAME MASTER CONNECTION DIAGRAM

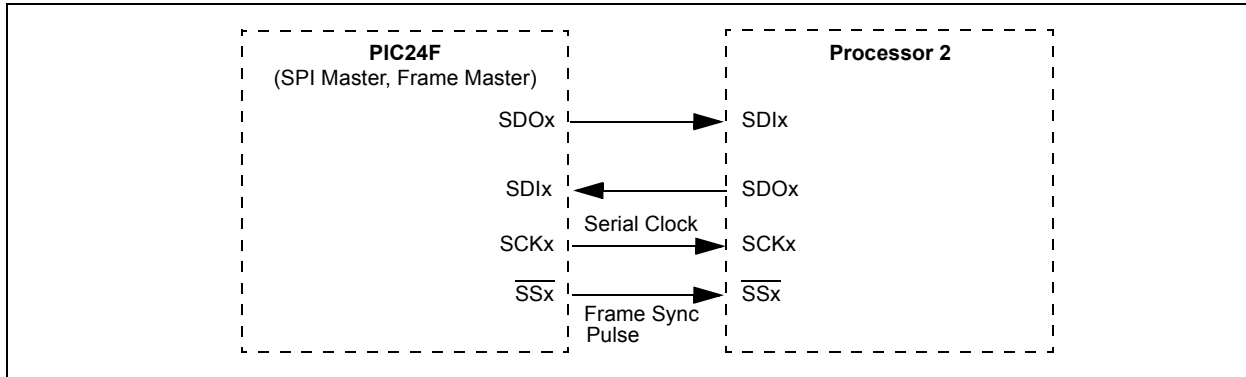

FIGURE 15-6: SPI MASTER, FRAME SLAVE CONNECTION DIAGRAM

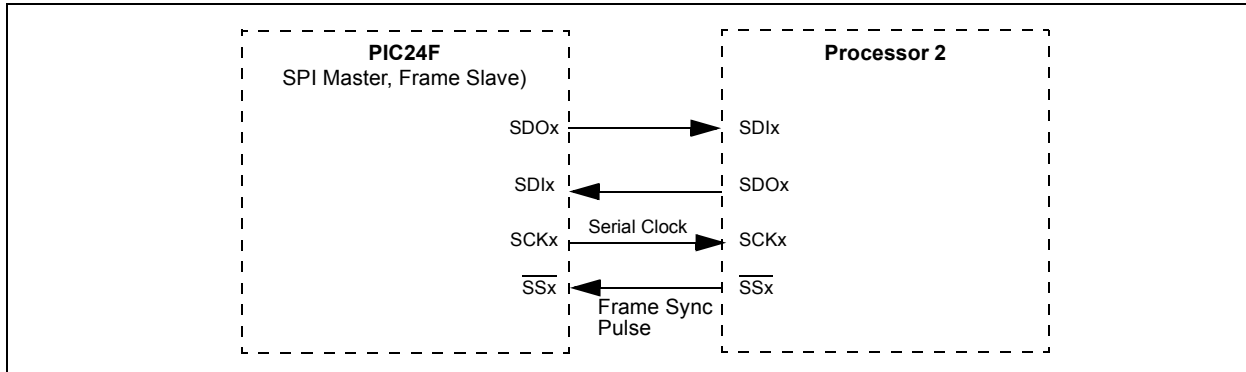

FIGURE 15-7: SPI SLAVE, FRAME MASTER CONNECTION DIAGRAM

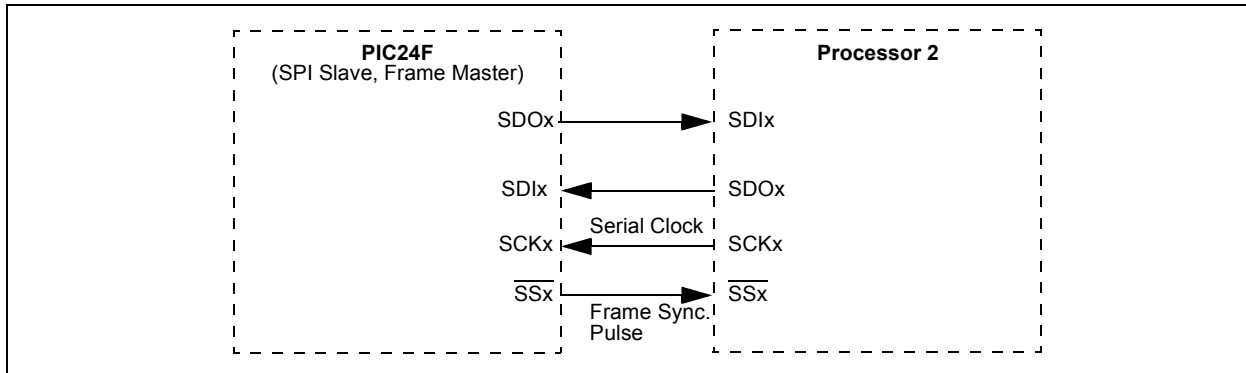
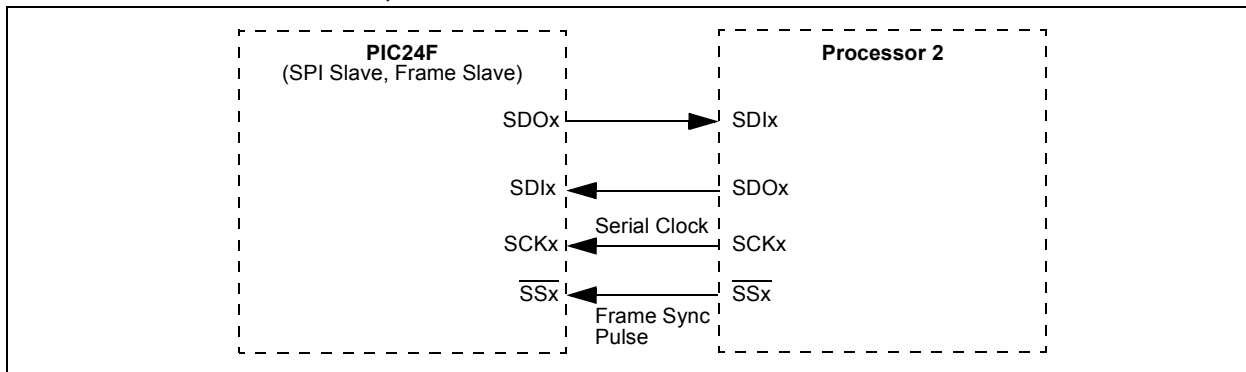

FIGURE 15-8: SPI SLAVE, FRAME SLAVE CONNECTION DIAGRAM



PIC24FJ256DA210 FAMILY

[查询PIC24FJ256DA106供应商](#)

EQUATION 15-1: RELATIONSHIP BETWEEN DEVICE AND SPI CLOCK SPEED⁽¹⁾

$$F_{SCK} = \frac{F_{CY}}{\text{Primary Prescaler} \times \text{Secondary Prescaler}}$$

Note 1: Based on $F_{CY} = F_{OSC}/2$; Doze mode and PLL are disabled.

TABLE 15-1: SAMPLE SCKx FREQUENCIES^(1,2)

| Fcy = 16 MHz | | Secondary Prescaler Settings | | | | |
|----------------------------|------|------------------------------|------|------|------|------|
| | | 1:1 | 2:1 | 4:1 | 6:1 | 8:1 |
| Primary Prescaler Settings | 1:1 | Invalid | 8000 | 4000 | 2667 | 2000 |
| | 4:1 | 4000 | 2000 | 1000 | 667 | 500 |
| | 16:1 | 1000 | 500 | 250 | 167 | 125 |
| | 64:1 | 250 | 125 | 63 | 42 | 31 |
| Fcy = 5 MHz | | | | | | |
| Primary Prescaler Settings | 1:1 | 5000 | 2500 | 1250 | 833 | 625 |
| | 4:1 | 1250 | 625 | 313 | 208 | 156 |
| | 16:1 | 313 | 156 | 78 | 52 | 39 |
| | 64:1 | 78 | 39 | 20 | 13 | 10 |

Note 1: Based on $F_{CY} = F_{OSC}/2$; Doze mode and PLL are disabled.

2: SCKx frequencies shown in kHz.

PIC24FJ256DA210 FAMILY

[查询PIC24FJ256DA106供应商](#)

NOTES:

PIC24FJ256DA210 FAMILY

[查询PIC24FJ256DA106供应商](#)

16.0 INTER-INTEGRATED CIRCUIT™ (I²C™)

Note: This data sheet summarizes the features of this group of PIC24F devices. It is not intended to be a comprehensive reference source. For more information, refer to the “PIC24F Family Reference Manual”, Section 24. “Inter-Integrated Circuit™ (I²C™)” (DS39702). The information in this data sheet supersedes the information in the FRM.

The Inter-Integrated Circuit™ (I²C™) module is a serial interface useful for communicating with other peripheral or microcontroller devices. These peripheral devices may be serial EEPROMs, display drivers, A/D Converters, etc.

The I²C module supports these features:

- Independent master and slave logic
- 7-bit and 10-bit device addresses
- General call address, as defined in the I²C protocol
- Clock stretching to provide delays for the processor to respond to a slave data request
- Both 100 kHz and 400 kHz bus specifications
- Configurable address masking
- Multi-Master modes to prevent loss of messages in arbitration
- Bus Repeater mode, allowing the acceptance of all messages as a slave regardless of the address
- Automatic SCL

A block diagram of the module is shown in Figure 16-1.

16.1 Communicating as a Master in a Single Master Environment

The details of sending a message in Master mode depends on the communications protocol for the device being communicated with. Typically, the sequence of events is as follows:

1. Assert a Start condition on SDAx and SCLx.
2. Send the I²C device address byte to the slave with a write indication.
3. Wait for and verify an Acknowledge from the slave.
4. Send the first data byte (sometimes known as the command) to the slave.
5. Wait for and verify an Acknowledge from the slave.
6. Send the serial memory address low byte to the slave.
7. Repeat steps 4 and 5 until all data bytes are sent.
8. Assert a Repeated Start condition on SDAx and SCLx.
9. Send the device address byte to the slave with a read indication.
10. Wait for and verify an Acknowledge from the slave.
11. Enable master reception to receive serial memory data.
12. Generate an ACK or NACK condition at the end of a received byte of data.
13. Generate a Stop condition on SDAx and SCLx.

PIC24FJ256DA210 FAMILY

[查询PIC24FJ256DA106供应商](#)

FIGURE 16-1: I²C™ BLOCK DIAGRAM

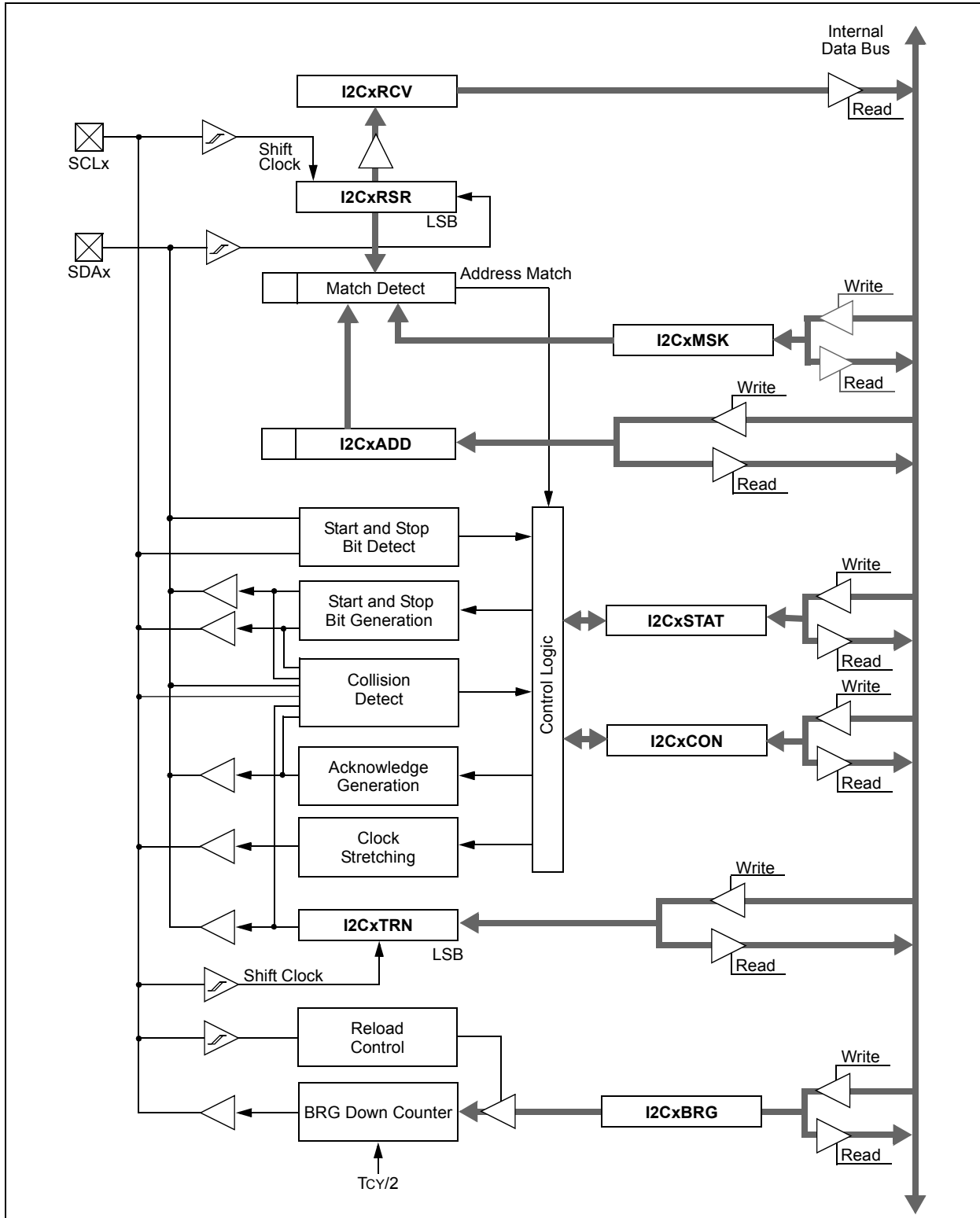

PIC24FJ256DA210 FAMILY

[查询PIC24FJ256DA106供应商](#)

16.2 Setting Baud Rate When Operating as a Bus Master

To compute the Baud Rate Generator reload value, use Equation 16-1.

EQUATION 16-1: COMPUTING BAUD RATE RELOAD VALUE^(1,2)

$$F_{SCL} = \frac{F_{CY}}{I2CxBRG + 1 + \frac{F_{CY}}{10,000,000}}$$

or:

$$I2CxBRG = \left(\frac{F_{CY}}{F_{SCL}} - \frac{F_{CY}}{10,000,000} - 1 \right)$$

Note 1: Based on $F_{CY} = F_{OSC}/2$; Doze mode and PLL are disabled.

2: These clock rate values are for guidance only. The actual clock rate can be affected by various system level parameters. The actual clock rate should be measured in its intended application.

16.3 Slave Address Masking

The I2CxMSK register (Register 16-3) designates address bit positions as “don’t care” for both 7-Bit and 10-Bit Addressing modes. Setting a particular bit location (= 1) in the I2CxMSK register causes the slave module to respond whether the corresponding address bit value is a ‘0’ or a ‘1’. For example, when I2CxMSK is set to ‘00100000’, the slave module will detect both addresses, ‘0000000’ and ‘0100000’.

To enable address masking, the Intelligent Peripheral Management Interface (IPMI) must be disabled by clearing the IPMIEN bit (I2CxCON<11>).

Note: As a result of changes in the I²C™ protocol, the addresses in Table 16-2 are reserved and will not be Acknowledged in Slave mode. This includes any address mask settings that include any of these addresses.

TABLE 16-1: I2C™ CLOCK RATES^(1,2)

| Required System F _{SCL} | F _{CY} | I2CxBRG Value | | Actual F _{SCL} |
|----------------------------------|-----------------|---------------|---------------|-------------------------|
| | | (Decimal) | (Hexadecimal) | |
| 100 kHz | 16 MHz | 157 | 9D | 100 kHz |
| 100 kHz | 8 MHz | 78 | 4E | 100 kHz |
| 100 kHz | 4 MHz | 39 | 27 | 99 kHz |
| 400 kHz | 16 MHz | 37 | 25 | 404 kHz |
| 400 kHz | 8 MHz | 18 | 12 | 404 kHz |
| 400 kHz | 4 MHz | 9 | 9 | 385 kHz |
| 400 kHz | 2 MHz | 4 | 4 | 385 kHz |
| 1 MHz | 16 MHz | 13 | D | 1.026 MHz |
| 1 MHz | 8 MHz | 6 | 6 | 1.026 MHz |
| 1 MHz | 4 MHz | 3 | 3 | 0.909 MHz |

Note 1: Based on $F_{CY} = F_{OSC}/2$; Doze mode and PLL are disabled.

2: These clock rate values are for guidance only. The actual clock rate can be affected by various system level parameters. The actual clock rate should be measured in its intended application.

TABLE 16-2: I²C™ RESERVED ADDRESSES⁽¹⁾

| Slave Address | R/W Bit | Description |
|---------------|---------|--|
| 0000 000 | 0 | General Call Address ⁽²⁾ |
| 0000 000 | 1 | Start Byte |
| 0000 001 | x | CBus Address |
| 0000 01x | x | Reserved |
| 0000 1xx | x | HS Mode Master Code |
| 1111 0xx | x | 10-Bit Slave Upper Byte ⁽³⁾ |
| 1111 1xx | x | Reserved |

Note 1: The address bits listed here will never cause an address match, independent of address mask settings.

2: The address will be Acknowledged only if GCEN = 1.

3: A match on this address can only occur on the upper byte in 10-Bit Addressing mode.

PIC24FJ256DA210 FAMILY

[查询PIC24FJ256DA106供应商](#)

REGISTER 16-1: I2CxCON: I2Cx CONTROL REGISTER

| | | | | | | | |
|--------|-----|---------|-----------|--------|-------|--------|-------|
| R/W-0 | U-0 | R/W-0 | R/W-1, HC | R/W-0 | R/W-0 | R/W-0 | R/W-0 |
| I2CEN | — | I2CSIDL | SCLREL | IPMIEN | A10M | DISSLW | SMEN |
| bit 15 | | | | | | | bit 8 |

| | | | | | | | |
|-------|-------|-------|-----------|-----------|-----------|-----------|-----------|
| R/W-0 | R/W-0 | R/W-0 | R/W-0, HC | R/W-0, HC | R/W-0, HC | R/W-0, HC | R/W-0, HC |
| GCEN | STREN | ACKDT | ACKEN | RCEN | PEN | RSEN | SEN |
| bit 7 | | | | | | | bit 0 |

| | |
|-------------------|------------------------------------|
| Legend: | HC = Hardware Clearable bit |
| R = Readable bit | W = Writable bit |
| -n = Value at POR | '1' = Bit is set |
| | U = Unimplemented bit, read as '0' |
| | '0' = Bit is cleared |
| | x = Bit is unknown |

- bit 15 **I2CEN:** I2Cx Enable bit
 1 = Enables the I2Cx module and configures the SDAx and SCLx pins as serial port pins
 0 = Disables the I2Cx module. All I²C™ pins are controlled by port functions
- bit 14 **Unimplemented:** Read as '0'
- bit 13 **I2CSIDL:** Stop in Idle Mode bit
 1 = Discontinues module operation when device enters an Idle mode
 0 = Continues module operation in Idle mode
- bit 12 **SCLREL:** SCLx Release Control bit (when operating as I²C slave)
 1 = Releases SCLx clock
 0 = Holds SCLx clock low (clock stretch)
If STREN = 1:
 Bit is R/W (i.e., software may write '0' to initiate stretch and write '1' to release clock). Hardware is clear at the beginning of slave transmission. Hardware is clear at the end of slave reception.
If STREN = 0:
 Bit is R/S (i.e., software may only write '1' to release clock). Hardware clear at beginning of slave transmission.
- bit 11 **IPMIEN:** Intelligent Platform Management Interface (IPMI) Enable bit
 1 = IPMI Support mode is enabled; all addresses are Acknowledged
 0 = IPMI mode is disabled
- bit 10 **A10M:** 10-Bit Slave Addressing bit
 1 = I2CxADD is a 10-bit slave address
 0 = I2CxADD is a 7-bit slave address
- bit 9 **DISSLW:** Disable Slew Rate Control bit
 1 = Slew rate control disabled
 0 = Slew rate control enabled
- bit 8 **SMEN:** SMBus Input Levels bit
 1 = Enables I/O pin thresholds compliant with SMBus specifications
 0 = Disables the SMBus input thresholds
- bit 7 **GCEN:** General Call Enable bit (when operating as I²C slave)
 1 = Enables interrupt when a general call address is received in the I2CxRSR (module is enabled for reception)
 0 = General call address disabled
- bit 6 **STREN:** SCLx Clock Stretch Enable bit (when operating as I²C slave)
 Used in conjunction with the SCLREL bit.
 1 = Enables software or receive clock stretching
 0 = Disables software or receive clock stretching

PIC24FJ256DA210 FAMILY

[查询PIC24FJ256DA106供应商](#)

REGISTER 16-1: I2CxCON: I2Cx CONTROL REGISTER (CONTINUED)

- bit 5 **ACKDT:** Acknowledge Data bit (when operating as I²C master. Applicable during master receive.)
Value that will be transmitted when the software initiates an Acknowledge sequence.
1 = Sends NACK during Acknowledge
0 = Sends ACK during Acknowledge
- bit 4 **ACKEN:** Acknowledge Sequence Enable bit (when operating as I²C master. Applicable during master receive.)
1 = Initiates Acknowledge sequence on SDAx and SCLx pins and transmits the ACKDT data bit. Hardware is clear at the end of the master Acknowledge sequence.
0 = Acknowledge sequence is not in progress
- bit 3 **RCEN:** Receive Enable bit (when operating as I²C master)
1 = Enables Receive mode for I²C. Hardware is clear at the end of the eighth bit of the master receive data byte.
0 = Receive sequence is not in progress
- bit 2 **PEN:** Stop Condition Enable bit (when operating as I²C master)
1 = Initiates Stop condition on the SDAx and SCLx pins. Hardware is clear at the end of the master Stop sequence.
0 = Stop condition is not in progress
- bit 1 **RSEN:** Repeated Start Condition Enabled bit (when operating as I²C master)
1 = Initiates Repeated Start condition on the SDAx and SCLx pins. Hardware is clear at the end of the master Repeated Start sequence
0 = Repeated Start condition is not in progress
- bit 0 **SEN:** Start Condition Enabled bit (when operating as I²C master)
1 = Initiates Start condition on SDAx and SCLx pins. Hardware is clear at end of the master Start sequence.
0 = Start condition is not in progress

PIC24FJ256DA210 FAMILY

[查询PIC24FJ256DA106供应商](#)

REGISTER 16-2: I2CxSTAT: I2Cx STATUS REGISTER

| | | | | | | | |
|----------|----------|-----|-----|-----|-----------|----------|----------|
| R-0, HSC | R-0, HSC | U-0 | U-0 | U-0 | R/C-0, HS | R-0, HSC | R-0, HSC |
| ACKSTAT | TRSTAT | — | — | — | BCL | GCSTAT | ADD10 |
| bit 15 | | | | | | | bit 8 |

| | | | | | | | |
|-----------|-----------|----------|------------|------------|----------|----------|----------|
| R/C-0, HS | R/C-0, HS | R-0, HSC | R/C-0, HSC | R/C-0, HSC | R-0, HSC | R-0, HSC | R-0, HSC |
| IWCOL | I2COV | D/A | P | S | R/W | RBF | TBF |
| bit 7 | | | | | | | bit 0 |

| | | |
|---------------------------------------|-------------------|------------------------------------|
| Legend: | C = Clearable bit | HS = Hardware Settable bit |
| R = Readable bit | W = Writable bit | U = Unimplemented bit, read as '0' |
| -n = Value at POR | '1' = Bit is set | '0' = Bit is cleared |
| HSC = Hardware Settable/Clearable bit | | x = Bit is unknown |

- bit 15 **ACKSTAT:** Acknowledge Status bit
 1 = NACK was detected last
 0 = ACK was detected last
 Hardware is set or clear at the end of Acknowledge.
- bit 14 **TRSTAT:** Transmit Status bit
 (When operating as I²C™ master. Applicable to master transmit operation.)
 1 = Master transmit is in progress (8 bits + ACK)
 0 = Master transmit is not in progress
 Hardware is set at the beginning of master transmission; hardware is clear at the end of slave Acknowledge.
- bit 13-11 **Unimplemented:** Read as '0'
- bit 10 **BCL:** Master Bus Collision Detect bit
 1 = A bus collision has been detected during a master operation
 0 = No collision
 Hardware is set at the detection of a bus collision.
- bit 9 **GCSTAT:** General Call Status bit
 1 = General call address was received
 0 = General call address was not received
 Hardware is set when the address matches the general call address; hardware is clear at Stop detection.
- bit 8 **ADD10:** 10-Bit Address Status bit
 1 = 10-bit address was matched
 0 = 10-bit address was not matched
 Hardware is set at the match of the 2nd byte of the matched 10-bit address; hardware is clear at Stop detection.
- bit 7 **IWCOL:** Write Collision Detect bit
 1 = An attempt to write to the I2CxTRN register failed because the I²C module is busy
 0 = No collision
 Hardware is set at an occurrence of write to I2CxTRN while busy (cleared by software).
- bit 6 **I2COV:** Receive Overflow Flag bit
 1 = A byte was received while the I2CxRCV register is still holding the previous byte
 0 = No overflow
 Hardware is set at an attempt to transfer I2CxRSR to I2CxRCV (cleared by software).
- bit 5 **D/A:** Data/Address bit (when operating as I²C slave)
 1 = Indicates that the last byte received was data
 0 = Indicates that the last byte received was a device address
 Hardware is clear at the device address match. Hardware is set after a transmission finishes or by reception of a slave byte.

PIC24FJ256DA210 FAMILY

[查询PIC24FJ256DA106供应商](#)

REGISTER 16-2: I2CxSTAT: I2Cx STATUS REGISTER (CONTINUED)

- bit 4 **P:** Stop bit
1 = Indicates that a Stop bit has been detected last
0 = Stop bit was not detected last
Hardware is set or clear when Start, Repeated Start or Stop is detected.
- bit 3 **S:** Start bit
1 = Indicates that a Start (or Repeated Start) bit has been detected last
0 = Start bit was not detected last
Hardware is set or clear when Start, Repeated Start or Stop is detected.
- bit 2 **R/W:** Read/Write Information bit (when operating as I²C slave)
1 = Read – indicates data transfer is output from slave
0 = Write – indicates data transfer is input to slave
Hardware is set or clear after the reception of an I²C device address byte.
- bit 1 **RBF:** Receive Buffer Full Status bit
1 = Receive is complete, I2CxRCV is full
0 = Receive not complete, I2CxRCV is empty
Hardware is set when I2CxRCV is written with the received byte; hardware is clear when the software reads I2CxRCV.
- bit 0 **TBF:** Transmit Buffer Full Status bit
1 = Transmit is in progress, I2CxTRN is full
0 = Transmit is complete, I2CxTRN is empty
Hardware is set when software writes to I2CxTRN; hardware is clear at the completion of data transmission.

PIC24FJ256DA210 FAMILY

[查询PIC24FJ256DA106供应商](#)

REGISTER 16-3: I2CxMSK: I2Cx SLAVE MODE ADDRESS MASK REGISTER

| | | | | | | | |
|--------|-----|-----|-----|-----|-----|-------|-------|
| U-0 | U-0 | U-0 | U-0 | U-0 | U-0 | R/W-0 | R/W-0 |
| — | — | — | — | — | — | AMSK9 | AMSK8 |
| bit 15 | | | | | | bit 8 | |

| | | | | | | | |
|-------|-------|-------|-------|-------|-------|-------|-------|
| R/W-0 | R/W-0 | R/W-0 | R/W-0 | R/W-0 | R/W-0 | R/W-0 | R/W-0 |
| AMSK7 | AMSK6 | AMSK5 | AMSK4 | AMSK3 | AMSK2 | AMSK1 | AMSK0 |
| bit 7 | | | | | | bit 0 | |

Legend:

R = Readable bit

W = Writable bit

U = Unimplemented bit, read as '0'

-n = Value at POR

'1' = Bit is set

'0' = Bit is cleared

x = Bit is unknown

bit 15-10

Unimplemented: Read as '0'

bit 9-0

AMSK<9:0>: Mask for Address Bit x Select bits

1 = Enable masking for bit x of the incoming message address; bit match is not required in this position

0 = Disable masking for bit x; bit match is required in this position

PIC24FJ256DA210 FAMILY

[查询PIC24FJ256DA106供应商](#)

17.0 UNIVERSAL ASYNCHRONOUS RECEIVER TRANSMITTER (UART)

Note: This data sheet summarizes the features of this group of PIC24F devices. It is not intended to be a comprehensive reference source. For more information, refer to the “PIC24F Family Reference Manual”, Section 21. “UART” (DS39708). The information in this data sheet supersedes the information in the FRM.

The Universal Asynchronous Receiver Transmitter (UART) module is one of the serial I/O modules available in the PIC24F device family. The UART is a full-duplex, asynchronous system that can communicate with peripheral devices, such as personal computers, LIN/J2602, RS-232 and RS-485 interfaces. The module also supports a hardware flow control option with the \overline{UxCTS} and \overline{UxRTS} pins, and also includes an IrDA® encoder and decoder.

The primary features of the UART module are:

- Full-Duplex, 8 or 9-Bit data transmission through the $UxTX$ and $UxRX$ pins
- Even, Odd or No Parity options (for 8-bit data)
- One or two Stop bits
- Hardware Flow Control option with the \overline{UxCTS} and \overline{UxRTS} pins

- Fully Integrated Baud Rate Generator with 16-Bit Prescaler
- Baud Rates Ranging from 15 bps to 1 Mbps at 16 MIPS
- 4-Deep, First-In-First-Out (FIFO) Transmit Data Buffer
- 4-Deep FIFO Receive Data Buffer
- Parity, Framing and Buffer Overrun Error Detection
- Support for 9-bit mode with Address Detect (9th bit = 1)
- Transmit and Receive Interrupts
- Loopback mode for Diagnostic Support
- Support for Sync and Break Characters
- Supports Automatic Baud Rate Detection
- IrDA® Encoder and Decoder Logic
- 16x Baud Clock Output for IrDA Support

A simplified block diagram of the UART is shown in Figure 17-1. The UART module consists of these key important hardware elements:

- Baud Rate Generator
- Asynchronous Transmitter
- Asynchronous Receiver

FIGURE 17-1: UART SIMPLIFIED BLOCK DIAGRAM

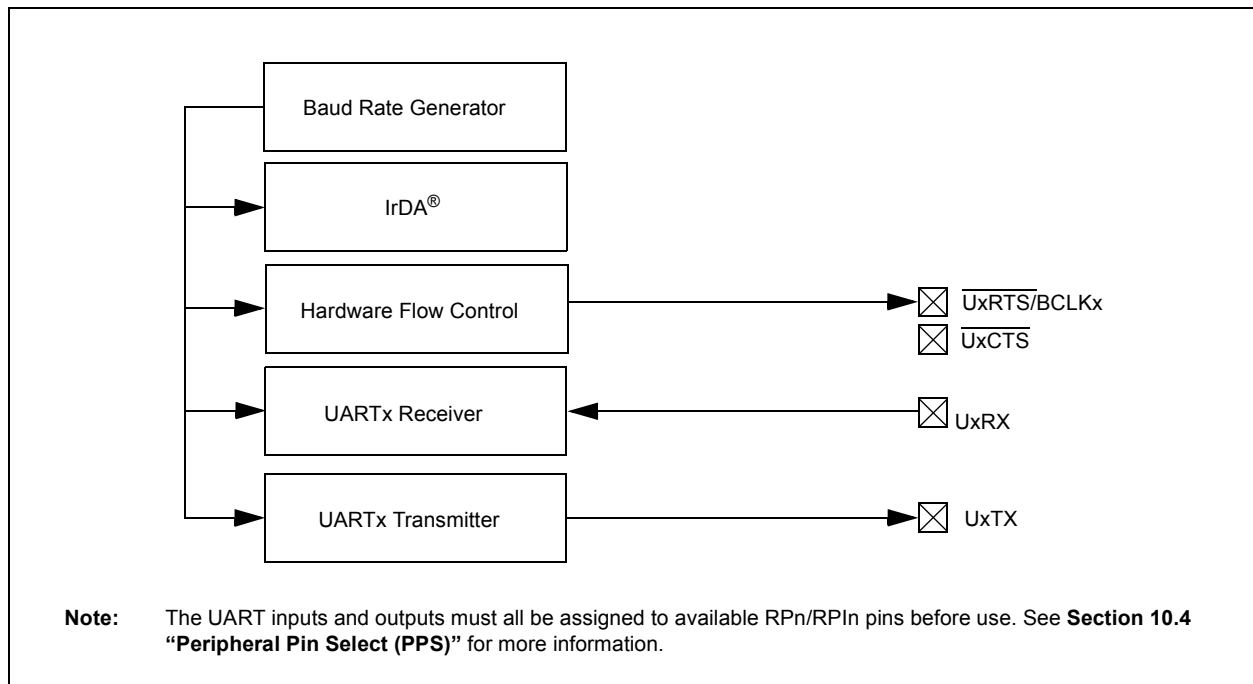

PIC24FJ256DA210 FAMILY

[查询PIC24FJ256DA106供应商](#)

17.1 UART Baud Rate Generator (BRG)

The UART module includes a dedicated, 16-bit Baud Rate Generator. The UxBRG register controls the period of a free-running, 16-bit timer. Equation 17-1 shows the formula for computation of the baud rate with BRGH = 0.

EQUATION 17-1: UART BAUD RATE WITH BRGH = 0^(1,2)

$$\text{Baud Rate} = \frac{\text{FCY}}{16 \cdot (\text{UxBRG} + 1)}$$
$$\text{UxBRG} = \frac{\text{FCY}}{16 \cdot \text{Baud Rate}} - 1$$

- Note 1:** FCY denotes the instruction cycle clock frequency (FOSC/2).
- 2:** Based on FCY = FOSC/2; Doze mode and PLL are disabled.

Example 17-1 shows the calculation of the baud rate error for the following conditions:

- FCY = 4 MHz
- Desired Baud Rate = 9600

EXAMPLE 17-1: BAUD RATE ERROR CALCULATION (BRGH = 0)⁽¹⁾

$$\text{Desired Baud Rate} = \text{FCY}/(16 (\text{BRGx} + 1))$$

Solving for BRGx Value:

$$\begin{aligned}\text{BRGx} &= ((\text{FCY}/\text{Desired Baud Rate})/16) - 1 \\ \text{BRGx} &= ((4000000/9600)/16) - 1 \\ \text{BRGx} &= 25\end{aligned}$$

$$\begin{aligned}\text{Calculated Baud Rate} &= 4000000/(16 (25 + 1)) \\ &= 9615\end{aligned}$$

$$\begin{aligned}\text{Error} &= (\text{Calculated Baud Rate} - \text{Desired Baud Rate}) \\ &\quad \text{Desired Baud Rate} \\ &= (9615 - 9600)/9600\end{aligned}$$

Note: Based on FCY = FOSC/2; Doze mode and PLL are disabled.

The maximum baud rate (BRGH = 0) possible is FCY/16 (for UxBRG = 0) and the minimum baud rate possible is FCY/(16 * 65536).

Equation 17-2 shows the formula for computation of the baud rate with BRGH = 1.

EQUATION 17-2: UART BAUD RATE WITH BRGH = 1^(1,2)

$$\text{Baud Rate} = \frac{\text{FCY}}{4 \cdot (\text{UxBRG} + 1)}$$
$$\text{UxBRG} = \frac{\text{FCY}}{4 \cdot \text{Baud Rate}} - 1$$

- Note 1:** FCY denotes the instruction cycle clock frequency.
- 2:** Based on FCY = FOSC/2; Doze mode and PLL are disabled.

The maximum baud rate (BRGH = 1) possible is FCY/4 (for UxBRG = 0) and the minimum baud rate possible is FCY/(4 * 65536).

Writing a new value to the UxBRG register causes the BRG timer to be reset (cleared). This ensures the BRG does not wait for a timer overflow before generating the new baud rate.

PIC24FJ256DA210 FAMILY

[查询PIC24FJ256DA106供应商](#)

17.2 Transmitting in 8-Bit Data Mode

1. Set up the UART:
 - a) Write appropriate values for data, parity and Stop bits.
 - b) Write appropriate baud rate value to the UxBRG register.
 - c) Set up transmit and receive interrupt enable and priority bits.
2. Enable the UART.
3. Set the UTXEN bit (causes a transmit interrupt two cycles after being set).
4. Write a data byte to the lower byte of UxTXREG word. The value will be immediately transferred to the Transmit Shift Register (TSR) and the serial bit stream will start shifting out with the next rising edge of the baud clock.
5. Alternately, the data byte may be transferred while UTXEN = 0 and then the user may set UTXEN. This will cause the serial bit stream to begin immediately because the baud clock will start from a cleared state.
6. A transmit interrupt will be generated as per interrupt control bit, UTXISELx.

17.3 Transmitting in 9-Bit Data Mode

1. Set up the UART (as described in **Section 17.2** “**Transmitting in 8-Bit Data Mode**”).
2. Enable the UART.
3. Set the UTXEN bit (causes a transmit interrupt).
4. Write UxTXREG as a 16-bit value only.
5. A word write to UxTXREG triggers the transfer of the 9-bit data to the TSR. The serial bit stream will start shifting out with the first rising edge of the baud clock.
6. A transmit interrupt will be generated as per the setting of control bit, UTXISELx.

17.4 Break and Sync Transmit Sequence

The following sequence will send a message frame header, made up of a Break, followed by an auto-baud Sync byte.

1. Configure the UART for the desired mode.
2. Set UTXEN and UTXBRK to set up the Break character.
3. Load the UxTXREG with a dummy character to initiate transmission (value is ignored).
4. Write '55h' to UxTXREG; this loads the Sync character into the transmit FIFO.
5. After the Break has been sent, the UTXBRK bit is reset by hardware. The Sync character now transmits.

17.5 Receiving in 8-Bit or 9-Bit Data Mode

1. Set up the UART (as described in **Section 17.2** “**Transmitting in 8-Bit Data Mode**”).
2. Enable the UART.
3. A receive interrupt will be generated when one or more data characters have been received as per interrupt control bit, URXISELx.
4. Read the OERR bit to determine if an overrun error has occurred. The OERR bit must be reset in software.
5. Read UxRXREG.

The act of reading the UxRXREG character will move the next character to the top of the receive FIFO, including a new set of PERR and FERR values.

17.6 Operation of $\overline{\text{UxCTS}}$ and $\overline{\text{UxRTS}}$ Control Pins

UARTx Clear to Send ($\overline{\text{UxCTS}}$) and Request to Send ($\overline{\text{UxRTS}}$) are the two hardware controlled pins that are associated with the UART module. These two pins allow the UART to operate in Simplex and Flow Control mode. They are implemented to control the transmission and reception between the Data Terminal Equipment (DTE). The UEN<1:0> bits in the UxMODE register configure these pins.

17.7 Infrared Support

The UART module provides two types of infrared UART support: one is the IrDA clock output to support an external IrDA encoder and decoder device (legacy module support), and the other is the full implementation of the IrDA encoder and decoder. Note that because the IrDA modes require a 16x baud clock, they will only work when the BRGH bit (UxMODE<3>) is '0'.

17.7.1 IrDA CLOCK OUTPUT FOR EXTERNAL IrDA SUPPORT

To support external IrDA encoder and decoder devices, the BCLKx pin (same as the UxRTS pin) can be configured to generate the 16x baud clock. With UEN<1:0> = 11, the BCLKx pin will output the 16x baud clock if the UART module is enabled. It can be used to support the IrDA codec chip.

17.7.2 BUILT-IN IrDA ENCODER AND DECODER

The UART has full implementation of the IrDA encoder and decoder as part of the UART module. The built-in IrDA encoder and decoder functionality is enabled using the IREN bit (UxMODE<12>). When enabled (IREN = 1), the receive pin (UxRX) acts as the input from the infrared receiver. The transmit pin (UxTX) acts as the output to the infrared transmitter.

PIC24FJ256DA210 FAMILY

查询PIC24FJ256DA106供应商

REGISTER 17-1: UxMODE: UARTx MODE REGISTER

| | | | | | | | |
|-----------------------|-----|-------|---------------------|-------|-----|-------|-------|
| R/W-0 | U-0 | R/W-0 | R/W-0 | R/W-0 | U-0 | R/W-0 | R/W-0 |
| UARTEN ⁽¹⁾ | — | USIDL | IREN ⁽²⁾ | RTSMD | — | UEN1 | UEN0 |
| bit 15 | | | | | | bit 8 | |

| | | | | | | | |
|-----------|--------|-----------|-------|-------|--------|--------|-------|
| R/W-0, HC | R/W-0 | R/W-0, HC | R/W-0 | R/W-0 | R/W-0 | R/W-0 | R/W-0 |
| WAKE | LPBACK | ABAUD | RXINV | BRGH | PDSEL1 | PDSEL0 | STSEL |
| bit 7 | | | | | | bit 0 | |

| | |
|-------------------|------------------------------------|
| Legend: | HC = Hardware Clearable bit |
| R = Readable bit | W = Writable bit |
| -n = Value at POR | '1' = Bit is set |
| | U = Unimplemented bit, read as '0' |
| | '0' = Bit is cleared |
| | x = Bit is unknown |

- bit 15 **UARTEN:** UARTx Enable bit⁽¹⁾
 1 = UARTx is enabled; all UARTx pins are controlled by UARTx as defined by UEN<1:0>
 0 = UARTx is disabled; all UARTx pins are controlled by port latches; UARTx power consumption is minimal
- bit 14 **Unimplemented:** Read as '0'
- bit 13 **USIDL:** Stop in Idle Mode bit
 1 = Discontinue module operation when device enters Idle mode
 0 = Continue module operation in Idle mode
- bit 12 **IREN:** IrDA[®] Encoder and Decoder Enable bit⁽²⁾
 1 = IrDA encoder and decoder are enabled
 0 = IrDA encoder and decoder are disabled
- bit 11 **RTSMD:** Mode Selection for \overline{UxRTS} Pin bit
 1 = \overline{UxRTS} pin is in Simplex mode
 0 = \overline{UxRTS} pin is in Flow Control mode
- bit 10 **Unimplemented:** Read as '0'
- bit 9-8 **UEN<1:0>:** UARTx Enable bits
 11 = UxTX, UxRX and BCLKx pins are enabled and used; \overline{UxCTS} pin is controlled by port latches
 10 = UxTX, UxRX, \overline{UxCTS} and UxRTS pins are enabled and used
 01 = UxTX, UxRX and \overline{UxRTS} pins are enabled and used; \overline{UxCTS} pin is controlled by port latches
 00 = UxTX and UxRX pins are enabled and used; \overline{UxCTS} and \overline{UxRTS} /BCLKx pins are controlled by port latches
- bit 7 **WAKE:** Wake-up on Start Bit Detect During Sleep Mode Enable bit
 1 = UARTx will continue to sample the UxRX pin; interrupt is generated on the falling edge, bit is cleared in hardware on the following rising edge
 0 = No wake-up is enabled
- bit 6 **LPBACK:** UARTx Loopback Mode Select bit
 1 = Enable Loopback mode
 0 = Loopback mode is disabled
- bit 5 **ABAUD:** Auto-Baud Enable bit
 1 = Enable baud rate measurement on the next character – requires reception of a Sync field (55h); cleared in hardware upon completion
 0 = Baud rate measurement is disabled or completed

Note 1: If UARTEN = 1, the peripheral inputs and outputs must be configured to an available RPN/RPIn pin. See **Section 10.4 “Peripheral Pin Select (PPS)”** for more information.

2: This feature is only available for the 16x BRG mode (BRGH = 0).

PIC24FJ256DA210 FAMILY

[查询PIC24FJ256DA106供应商](#)

REGISTER 17-1: UxMODE: UARTx MODE REGISTER (CONTINUED)

- bit 4 **RXINV:** Receive Polarity Inversion bit
1 = UxRX Idle state is '0'
0 = UxRX Idle state is '1'
- bit 3 **BRGH:** High Baud Rate Enable bit
1 = High-Speed mode (4 BRG clock cycles per bit)
0 = Standard-Speed mode (16 BRG clock cycles per bit)
- bit 2-1 **PDSEL<1:0>:** Parity and Data Selection bits
11 = 9-bit data, no parity
10 = 8-bit data, odd parity
01 = 8-bit data, even parity
00 = 8-bit data, no parity
- bit 0 **STSEL:** Stop Bit Selection bit
1 = Two Stop bits
0 = One Stop bit

- Note 1:** If UARTEN = 1, the peripheral inputs and outputs must be configured to an available RPN/RPIn pin. See **Section 10.4 “Peripheral Pin Select (PPS)”** for more information.
- 2:** This feature is only available for the 16x BRG mode (BRGH = 0).

PIC24FJ256DA210 FAMILY

查询PIC24FJ256DA106供应商

REGISTER 17-2: UxSTA: UARTx STATUS AND CONTROL REGISTER

| | | | | | | | |
|----------|-----------------------|----------|-----|----------|----------------------|----------|----------|
| R/W-0 | R/W-0 | R/W-0 | U-0 | R/W-0 HC | R/W-0 | R-0, HSC | R-1, HSC |
| UTXISEL1 | UTXINV ⁽¹⁾ | UTXISEL0 | — | UTXBRK | UTXEN ⁽²⁾ | UTXBF | TRMT |
| bit 15 | | | | | | | bit 8 |

| | | | | | | | |
|----------|----------|-------|----------|----------|----------|-----------|----------|
| R/W-0 | R/W-0 | R/W-0 | R-1, HSC | R-0, HSC | R-0, HSC | R/C-0, HS | R-0, HSC |
| URXISEL1 | URXISEL0 | ADDEN | RIDLE | PERR | FERR | OERR | URXDA |
| bit 7 | | | | | | | bit 0 |

| | | |
|----------------------------|-----------------------------|---------------------------------------|
| Legend: | C = Clearable bit | HSC = Hardware Settable/Clearable bit |
| R = Readable bit | W = Writable bit | U = Unimplemented bit, read as '0' |
| -n = Value at POR | '1' = Bit is set | '0' = Bit is cleared |
| HS = Hardware Settable bit | HC = Hardware Clearable bit | x = Bit is unknown |

- bit 15,13 **UTXISEL<1:0>**: Transmission Interrupt Mode Selection bits
 11 = Reserved; do not use
 10 = Interrupt when a character is transferred to the Transmit Shift Register (TSR) and as a result, the transmit buffer becomes empty
 01 = Interrupt when the last character is shifted out of the Transmit Shift Register; all transmit operations are completed
 00 = Interrupt when a character is transferred to the Transmit Shift Register (this implies there is at least one character open in the transmit buffer)
- bit 14 **UTXINV**: IrDA[®] Encoder Transmit Polarity Inversion bit⁽¹⁾
IREN = 0:
 1 = UxTX is Idle '0'
 0 = UxTX is Idle '1'
IREN = 1:
 1 = UxTX is Idle '1'
 0 = UxTX is Idle '0'
- bit 12 **Unimplemented**: Read as '0'
- bit 11 **UTXBRK**: Transmit Break bit
 1 = Send Sync Break on next transmission – Start bit, followed by twelve '0' bits, followed by Stop bit; cleared by hardware upon completion
 0 = Sync Break transmission is disabled or completed
- bit 10 **UTXEN**: Transmit Enable bit⁽²⁾
 1 = Transmit is enabled, UxTX pin controlled by UARTx
 0 = Transmit is disabled, any pending transmission is aborted and the buffer is reset; UxTX pin is controlled by port.
- bit 9 **UTXBF**: Transmit Buffer Full Status bit (read-only)
 1 = Transmit buffer is full
 0 = Transmit buffer is not full, at least one more character can be written
- bit 8 **TRMT**: Transmit Shift Register Empty bit (read-only)
 1 = Transmit Shift Register is empty and transmit buffer is empty (the last transmission has completed)
 0 = Transmit Shift Register is not empty, a transmission is in progress or queued

Note 1: Value of bit only affects the transmit properties of the module when the IrDA[®] encoder is enabled (IREN = 1).

2: If UARTEN = 1, the peripheral inputs and outputs must be configured to an available RPN/RPIN pin. See **Section 10.4 “Peripheral Pin Select (PPS)”** for more information.

PIC24FJ256DA210 FAMILY

[查询PIC24FJ256DA106供应商](#)

REGISTER 17-2: UxSTA: UARTx STATUS AND CONTROL REGISTER (CONTINUED)

- bit 7-6 **URXISEL<1:0>**: Receive Interrupt Mode Selection bits
11 = Interrupt is set on an RSR transfer, making the receive buffer full (i.e., has 4 data characters)
10 = Interrupt is set on an RSR transfer, making the receive buffer 3/4 full (i.e., has 3 data characters)
0x = Interrupt is set when any character is received and transferred from the RSR to the receive buffer; receive buffer has one or more characters
- bit 5 **ADDEN**: Address Character Detect bit (bit 8 of received data = 1)
1 = Address Detect mode is enabled
If 9-bit mode is not selected, this does not take effect.
0 = Address Detect mode is disabled
- bit 4 **RIDLE**: Receiver Idle bit (read-only)
1 = Receiver is Idle
0 = Receiver is active
- bit 3 **PERR**: Parity Error Status bit (read-only)
1 = Parity error has been detected for the current character (character at the top of the receive FIFO)
0 = Parity error has not been detected
- bit 2 **FERR**: Framing Error Status bit (read-only)
1 = Framing error has been detected for the current character (character at the top of the receive FIFO)
0 = Framing error has not been detected
- bit 1 **OERR**: Receive Buffer Overrun Error Status bit (clear/read-only)
1 = Receive buffer has overflowed
0 = Receive buffer has not overflowed (clearing a previously set OERR bit (1 → 0 transition); will reset the receiver buffer and the RSR to the empty state)
- bit 0 **URXDA**: Receive Buffer Data Available bit (read-only)
1 = Receive buffer has data, at least one more character can be read
0 = Receive buffer is empty

- Note 1:** Value of bit only affects the transmit properties of the module when the IrDA[®] encoder is enabled (IREN = 1).
- 2:** If UARTEN = 1, the peripheral inputs and outputs must be configured to an available RPN/RPIn pin. See **Section 10.4 “Peripheral Pin Select (PPS)”** for more information.

PIC24FJ256DA210 FAMILY

[查询PIC24FJ256DA106供应商](#)

NOTES:

PIC24FJ256DA210 FAMILY

[查询PIC24FJ256DA106供应商](#)

18.0 UNIVERSAL SERIAL BUS WITH ON-THE-GO SUPPORT (USB OTG)

Note: This data sheet summarizes the features of this group of PIC24F devices. It is not intended to be a comprehensive reference source. For more information, refer to the “PIC24F Family Reference Manual”, Section 27. “USB On-The-Go (OTG)” (DS39721). The information in this data sheet supersedes the information in the FRM.

PIC24FJ256DA210 family devices contain a full-speed and low-speed compatible, On-The-Go (OTG) USB Serial Interface Engine (SIE). The OTG capability allows the device to act either as a USB peripheral device or as a USB embedded host with limited host capabilities. The OTG capability allows the device to dynamically switch from device to host operation using OTG’s Host Negotiation Protocol (HNP).

For more details on OTG operation, refer to the “On-The-Go Supplement to the USB 2.0 Specification”, published by the USB-IF. For more details on USB operation, refer to the “Universal Serial Bus Specification”, v2.0.

The USB OTG module offers these features:

- USB functionality in Device and Host modes, and OTG capabilities for application-controlled mode switching
- Software-selectable module speeds of full speed (12 Mbps) or low speed (1.5 Mbps, available in Host mode only)
- Support for all four USB transfer types: control, interrupt, bulk and isochronous
- 16 bidirectional endpoints for a total of 32 unique endpoints
- DMA interface for data RAM access
- Queues up to sixteen unique endpoint transfers without servicing
- Integrated, on-chip USB transceiver with support for off-chip transceivers via a digital interface
- Integrated VBUS generation with on-chip comparators and boost generation, and support of external VBUS comparators and regulators through a digital interface
- Configurations for on-chip bus pull-up and pull-down resistors

A simplified block diagram of the USB OTG module is shown in Figure 18-1.

The USB OTG module can function as a USB peripheral device or as a USB host, and may dynamically switch between Device and Host modes under software control. In either mode, the same data paths and Buffer Descriptors (BDs) are used for the transmission and reception of data.

In discussing USB operation, this section will use a controller-centric nomenclature for describing the direction of the data transfer between the microcontroller and the USB. RX (Receive) will be used to describe transfers that move data from the USB to the microcontroller and TX (Transmit) will be used to describe transfers that move data from the microcontroller to the USB. Table 18-1 shows the relationship between data direction in this nomenclature and the USB tokens exchanged.

TABLE 18-1: CONTROLLER-CENTRIC DATA DIRECTION FOR USB HOST OR TARGET

| USB Mode | Direction | |
|----------|--------------|--------------|
| | RX | TX |
| Device | OUT or SETUP | IN |
| Host | IN | OUT or SETUP |

This chapter presents the most basic operations needed to implement USB OTG functionality in an application. A complete and detailed discussion of the USB protocol and its OTG supplement are beyond the scope of this data sheet. It is assumed that the user already has a basic understanding of USB architecture and the latest version of the protocol.

Not all steps for proper USB operation (such as device enumeration) are presented here. It is recommended that application developers use an appropriate device driver to implement all of the necessary features. Microchip provides a number of application-specific resources, such as USB firmware and driver support. Refer to www.microchip.com/usb for the latest firmware and driver support.

PIC24FJ256DA210 FAMILY

[查询PIC24FJ256DA106供应商](#)

FIGURE 18-1: USB OTG MODULE BLOCK DIAGRAM

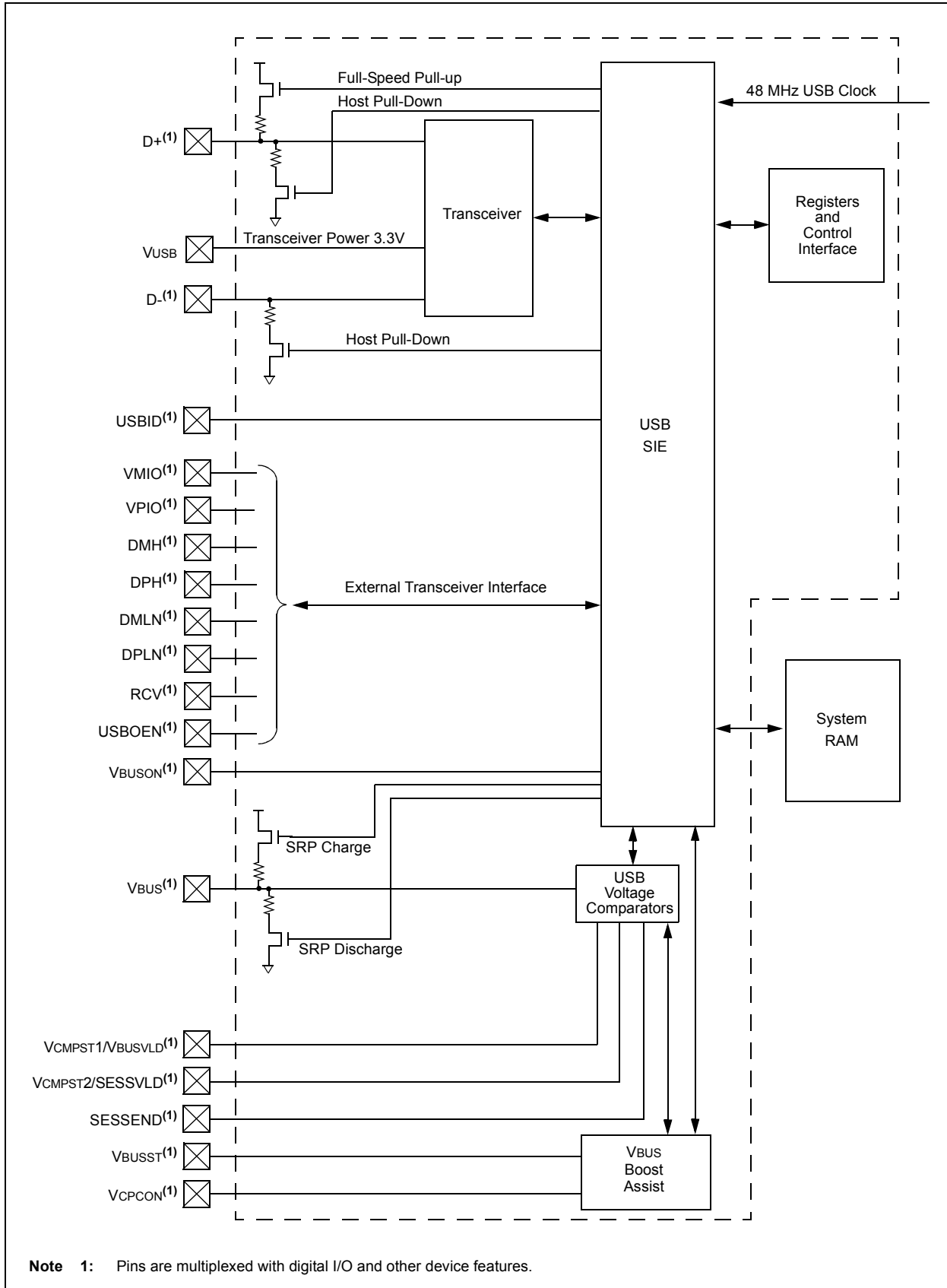

PIC24FJ256DA210 FAMILY

[查询PIC24FJ256DA106供应商](#)

18.1 Hardware Configuration

18.1.1 DEVICE MODE

18.1.1.1 D+ Pull-up Resistor

PIC24FJ256DA210 family devices have a built-in 1.5 k Ω resistor on the D+ line that is available when the microcontroller is operating in Device mode. This is used to signal an external Host that the device is operating in Full-Speed Device mode. It is engaged by setting the USBEN bit (U1CON<0>). If the OTGEN bit (U1OTGCON<2>) is set, then the D+ pull-up is enabled through the DPPULUP bit (U1OTGCON<7>).

Alternatively, an external resistor may be used on D+, as shown in Figure 18-2.

FIGURE 18-2: EXTERNAL PULL-UP FOR FULL-SPEED DEVICE MODE

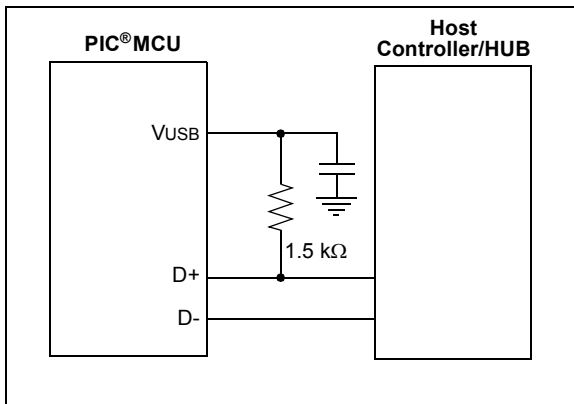

18.1.1.2 Power Modes

Many USB applications will likely have several different sets of power requirements and configuration. The most common power modes encountered are:

- Bus Power Only mode
- Self-Power Only mode
- Dual Power with Self-Power Dominance

Bus Power Only mode (Figure 18-3) is effectively the simplest method. All power for the application is drawn from the USB.

To meet the inrush current requirements of the USB 2.0 Specification, the total effective capacitance appearing across VBUS and ground must be no more than 10 μ F.

In the USB Suspend mode, devices must consume no more than 2.5 mA from the 5V VBUS line of the USB cable. During the USB Suspend mode, the D+ or D- pull-up resistor must remain active, which will consume some of the allowed suspend current.

In Self-Power Only mode (Figure 18-4), the USB application provides its own power, with very little power being pulled from the USB. Note that an attach indication is added to indicate when the USB has been connected and the host is actively powering VBUS.

To meet compliance specifications, the USB module (and the D+ or D- pull-up resistor) should not be enabled until the host actively drives VBUS high. One of the 5.5V tolerant I/O pins may be used for this purpose.

The application should never source any current onto the 5V VBUS pin of the USB cable.

The Dual Power mode with Self-Power Dominance (Figure 18-5) allows the application to use internal power primarily, but switch to power from the USB when no internal power is available. Dual power devices must also meet all of the special requirements for inrush current and Suspend mode current previously described, and must not enable the USB module until VBUS is driven high.

FIGURE 18-3: BUS POWER ONLY

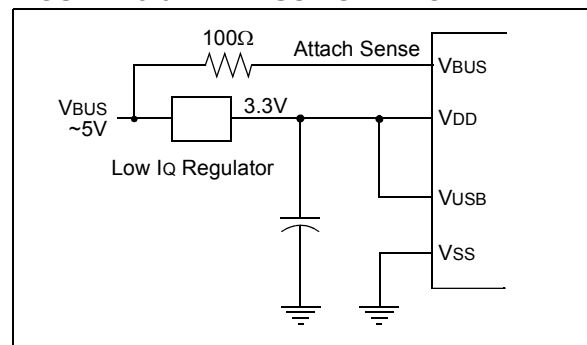

FIGURE 18-4: SELF-POWER ONLY

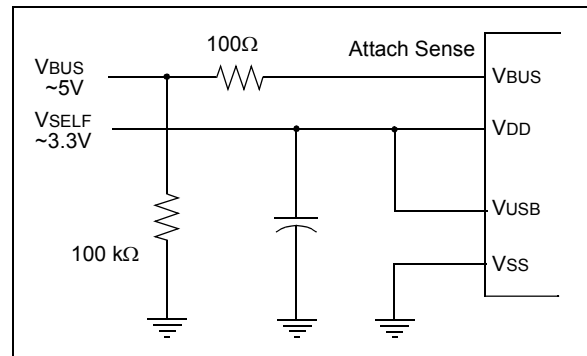
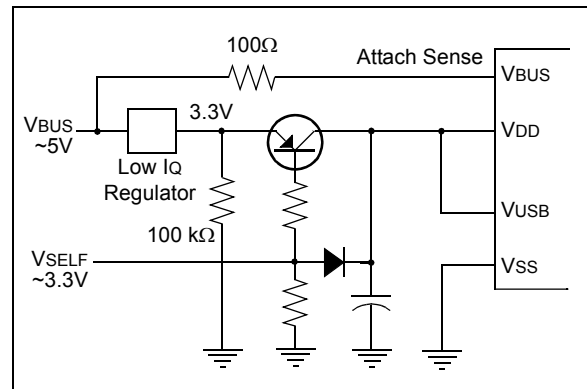

FIGURE 18-5: DUAL POWER EXAMPLE



PIC24FJ256DA210 FAMILY

[查询PIC24FJ256DA106供应商](#)

18.1.2 HOST AND OTG MODES

18.1.2.1 D+ and D- Pull-Down Resistors

PIC24FJ256DA210 family devices have a built-in 15 k Ω pull-down resistor on the D+ and D- lines. These are used in tandem to signal to the bus that the microcontroller is operating in Host mode. They are engaged by setting the HOSTEN bit (U1CON<3>). If the OTGEN bit (U1OTGCON<2>) is set, then these pull-downs are enabled by setting the DPPULDWN and DMPULDWN bits (U1OTGCON<5:4>).

18.1.2.2 Power Configurations

In Host mode, as well as Host mode in On-The-Go operation, the USB 2.0 Specification requires that the host application should supply power on VBUS. Since

the microcontroller is running below VBUS, and is not able to source sufficient current, a separate power supply must be provided.

When the application is always operating in Host mode, a simple circuit can be used to supply VBUS and regulate current on the bus (Figure 18-6). For OTG operation, it is necessary to be able to turn VBUS on or off as needed, as the microcontroller switches between Device and Host modes. A typical example using an external charge pump is shown in Figure 18-7.

FIGURE 18-6: HOST INTERFACE EXAMPLE

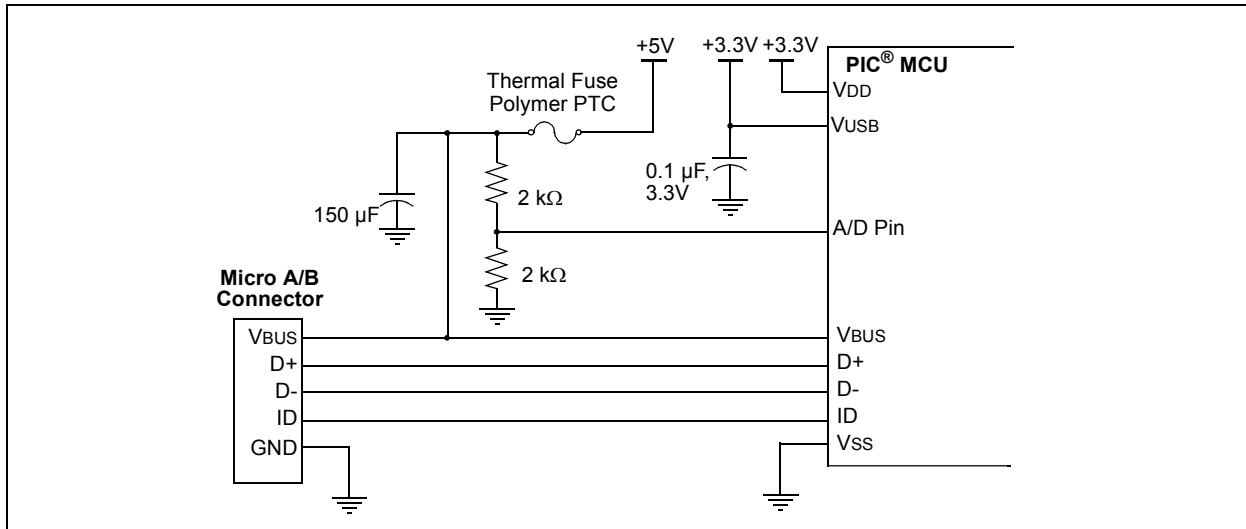
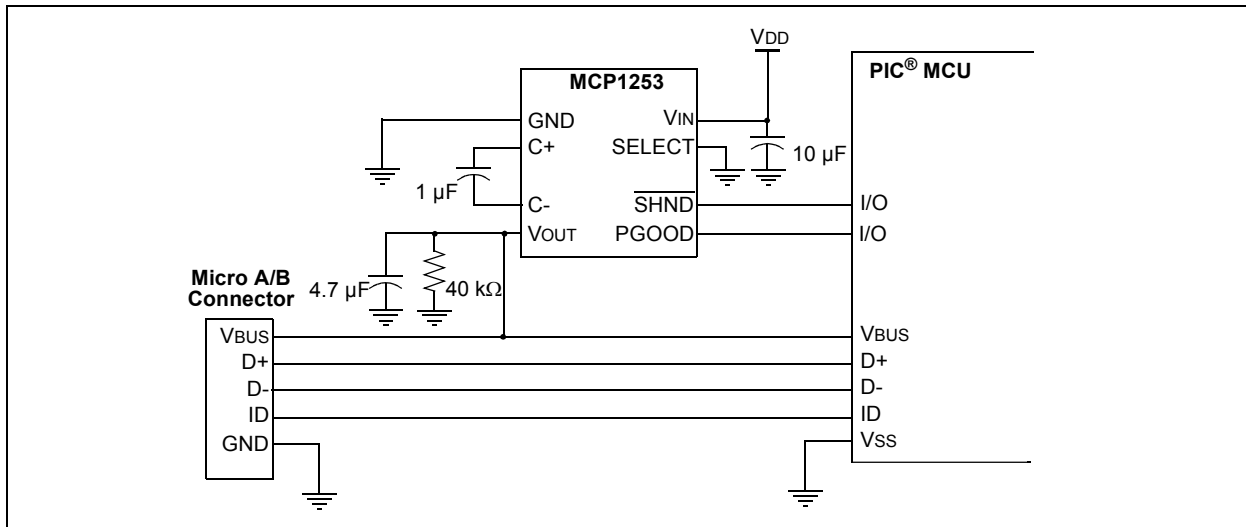

FIGURE 18-7: OTG INTERFACE EXAMPLE



PIC24FJ256DA210 FAMILY

[查询PIC24FJ256DA106供应商](#)

18.1.2.3 VBUS Voltage Generation with External Devices

When operating as a USB host, either as an A-device in an OTG configuration or as an embedded host, VBUS must be supplied to the attached device. PIC24FJ256DA210 family devices have an internal VBUS boost assist to help generate the required 5V VBUS from the available voltages on the board. This is comprised of a simple PWM output to control a Switch mode power supply, and built-in comparators to monitor output voltage and limit current.

To enable voltage generation:

1. Verify that the USB module is powered (U1PWRC<0> = 1) and that the VBUS discharge is disabled (U1OTGCON<0> = 0).
2. Set the PWM period (U1PWMRRS<7:0>) and duty cycle (U1PWMRRS<15:8>) as required.
3. Select the required polarity of the output signal based on the configuration of the external circuit with the PWMPOL bit (U1PWMCON<9>).
4. Select the desired target voltage using the VBUSCHG bit (U1OTGCON<1>).
5. Enable the PWM counter by setting the CNTEN bit to '1' (U1PWMCON<8>).
6. Enable the PWM module by setting the PWMEN bit (U1PWMCON<15>) to '1'.
7. Enable the VBUS generation circuit (U1OTGCON<3> = 1).

Note: This section describes the general process for VBUS voltage generation and control. Please refer to the “PIC24F Family Reference Manual” for additional examples.

18.1.3 USING AN EXTERNAL INTERFACE

Some applications may require the USB interface to be isolated from the rest of the system. PIC24FJ256DA210 family devices include a complete interface to communicate with and control an external USB transceiver, including the control of data line pull-ups and pull-downs. The VBUS voltage generation control circuit can also be configured for different VBUS generation topologies.

Refer to the “PIC24F Family Reference Manual”, **Section 27. “USB On-The-Go (OTG)”** for information on using the external interface.

18.1.4 CALCULATING TRANSCEIVER POWER REQUIREMENTS

The USB transceiver consumes a variable amount of current depending on the characteristic impedance of the USB cable, the length of the cable, the VUSB supply voltage and the actual data patterns moving across the USB cable. Longer cables have larger capacitances and consume more total energy when switching output states. The total transceiver current consumption will be application-specific. Equation 18-1 can help estimate how much current actually may be required in full-speed applications.

Refer to the “PIC24F Family Reference Manual”, **Section 27. “USB On-The-Go (OTG)”** for a complete discussion on transceiver power consumption.

EQUATION 18-1: ESTIMATING USB TRANSCEIVER CURRENT CONSUMPTION

$$I_{XCVR} = \frac{40 \text{ mA} \cdot V_{USB} \cdot P_{ZERO} \cdot P_{IN} \cdot L_{CABLE}}{3.3\text{V} \cdot 5\text{m}} + I_{PULLUP}$$

Legend: VUSB – Voltage applied to the VUSB pin in volts (3.0V to 3.6V).

PZERO – Percentage (in decimal) of the IN traffic bits sent by the PIC[®] microcontroller that are a value of '0'.

PIN – Percentage (in decimal) of total bus bandwidth that is used for IN traffic.

LCABLE – Length (in meters) of the USB cable. The USB 2.0 Specification requires that full-speed applications use cables no longer than 5m.

IPULLUP – Current which the nominal, 1.5 kΩ pull-up resistor (when enabled) must supply to the USB cable.

PIC24FJ256DA210 FAMILY

[查询PIC24FJ256DA106供应商](#)

18.2 USB Buffer Descriptors and the BDT

Endpoint buffer control is handled through a structure called the Buffer Descriptor Table (BDT). This provides a flexible method for users to construct and control endpoint buffers of various lengths and configurations.

The BDT can be located in any available, 512-byte aligned block of data RAM. The BDT Pointer (U1BDTP1) contains the upper address byte of the BDT and sets the location of the BDT in RAM. The user must set this pointer to indicate the table's location.

The BDT is composed of Buffer Descriptors (BDs) which are used to define and control the actual buffers in the USB RAM space. Each BD consists of two, 16-bit "soft" (non-fixed-address) registers, BDnSTAT and BDnADR, where n represents one of the 64 possible BDs (range of 0 to 63). BDnSTAT is the status register for BDn, while BDnADR specifies the starting address for the buffer associated with BDn.

Note: Since BDnADR is a 16-bit register, only the first 64 Kbytes of RAM can be accessed by the USB module.

Depending on the endpoint buffering configuration used, there are up to 64 sets of Buffer Descriptors, for a total of 256 bytes. At a minimum, the BDT must be at least 8 bytes long. This is because the USB Specification mandates that every device must have Endpoint 0 with both input and output for initial setup.

Endpoint mapping in the BDT is dependent on three variables:

- Endpoint number (0 to 15)
- Endpoint direction (RX or TX)
- Ping-pong settings (U1CNFG1<1:0>)

Figure 18-8 illustrates how these variables are used to map endpoints in the BDT.

In Host mode, only Endpoint 0 Buffer Descriptors are used. All transfers utilize the Endpoint 0 Buffer Descriptor and Endpoint Control register (U1EP0). For received packets, the attached device's source endpoint is indicated by the value of ENDPT<3:0> in the USB status register (U1STAT<7:4>). For transmitted packet, the attached device's destination endpoint is indicated by the value written to the Token register (U1TOK).

FIGURE 18-8: BDT MAPPING FOR ENDPOINT BUFFERING MODES

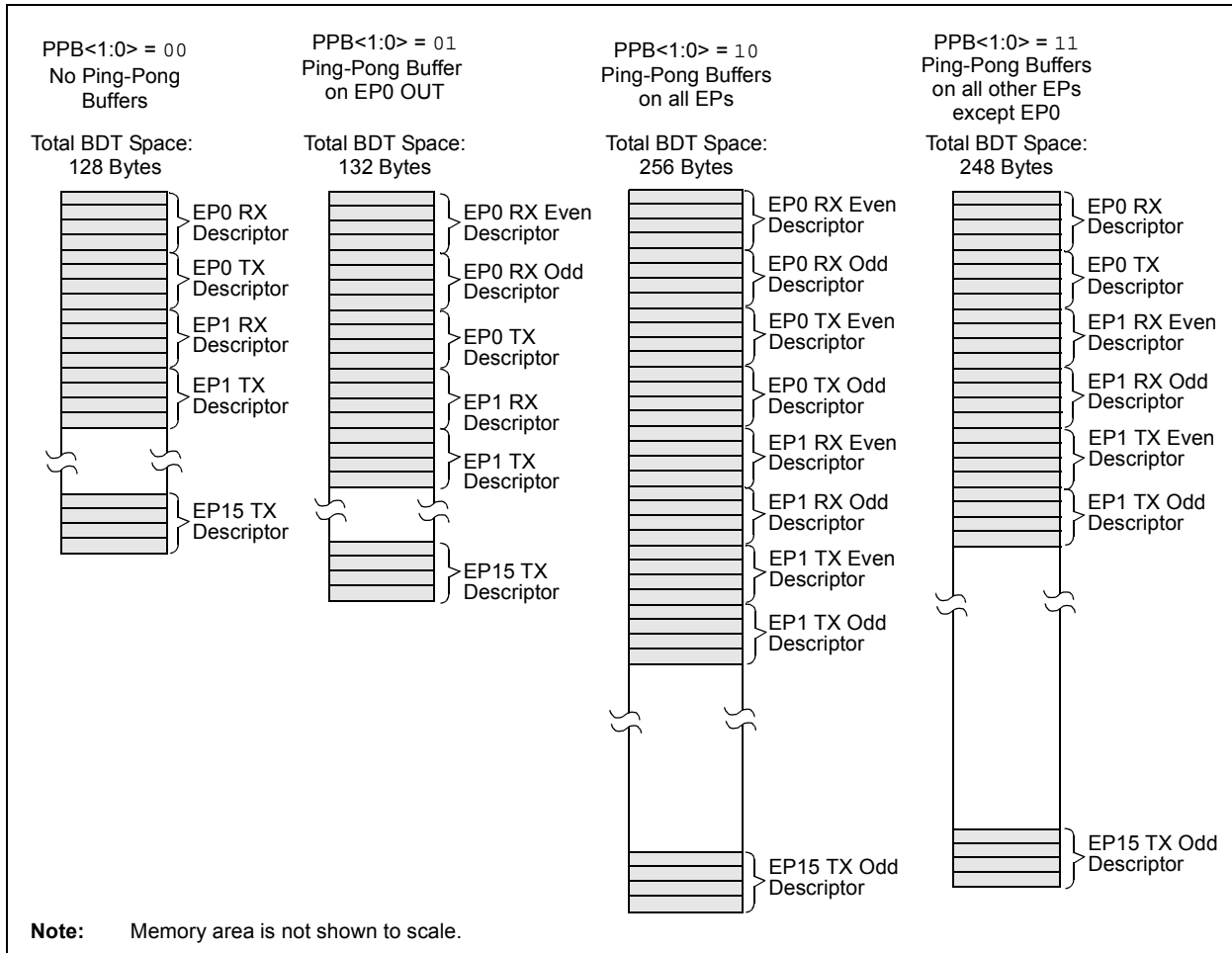

PIC24FJ256DA210 FAMILY

[查询PIC24FJ256DA106供应商](#)

BDs have a fixed relationship to a particular endpoint, depending on the buffering configuration. Table 18-2 provides the mapping of BDs to endpoints. This relationship also means that gaps may occur in the BDT if endpoints are not enabled contiguously. This, theoretically, means that the BDs for disabled endpoints could be used as buffer space. In practice, users should avoid using such spaces in the BDT unless a method of validating BD addresses is implemented.

18.2.1 BUFFER OWNERSHIP

Because the buffers and their BDs are shared between the CPU and the USB module, a simple semaphore mechanism is used to distinguish which is allowed to update the BD and associated buffers in memory. This is done by using the UOWN bit as a semaphore to distinguish which is allowed to update the BD and associated buffers in memory. UOWN is the only bit that is shared between the two configurations of BDnSTAT.

When UOWN is clear, the BD entry is “owned” by the microcontroller core. When the UOWN bit is set, the BD entry and the buffer memory are “owned” by the USB peripheral. The core should not modify the BD or its

corresponding data buffer during this time. Note that the microcontroller core can still read BDnSTAT while the SIE owns the buffer and vice versa.

The Buffer Descriptors have a different meaning based on the source of the register update. Register 18-1 and Register 18-2 show the differences in BDnSTAT depending on its current “ownership”.

When UOWN is set, the user can no longer depend on the values that were written to the BDs. From this point, the USB module updates the BDs as necessary, overwriting the original BD values. The BDnSTAT register is updated by the SIE with the token PID and the transfer count is updated.

18.2.2 DMA INTERFACE

The USB OTG module uses a dedicated DMA to access both the BDT and the endpoint data buffers. Since part of the address space of the DMA is dedicated to the Buffer Descriptors, a portion of the memory connected to the DMA must comprise a contiguous address space properly mapped for the access by the module.

TABLE 18-2: ASSIGNMENT OF BUFFER DESCRIPTORS FOR THE DIFFERENT BUFFERING MODES

| Endpoint | BDs Assigned to Endpoint | | | | | | | |
|----------|--------------------------|----|----------------------------------|----|----------------------------------|----------------|---|----------------|
| | Mode 0 (No Ping-Pong) | | Mode 1 (Ping-Pong on EP0 OUT) | | Mode 2 (Ping-Pong on all EPs) | | Mode 3 (Ping-Pong on all other EPs, except EP0) | |
| | Out | In | Out | In | Out | In | Out | In |
| 0 | 0 | 1 | 0 (E), 1 (O) | 2 | 0 (E), 1 (O) | 2 (E), 3 (O) | 0 | 1 |
| 1 | 2 | 3 | 3 | 4 | 4 (E), 5 (O) | 6 (E), 7 (O) | 2 (E), 3 (O) | 4 (E), 5 (O) |
| 2 | 4 | 5 | 5 | 6 | 8 (E), 9 (O) | 10 (E), 11 (O) | 6 (E), 7 (O) | 8 (E), 9 (O) |
| 3 | 6 | 7 | 7 | 8 | 12 (E), 13 (O) | 14 (E), 15 (O) | 10 (E), 11 (O) | 12 (E), 13 (O) |
| 4 | 8 | 9 | 9 | 10 | 16 (E), 17 (O) | 18 (E), 19 (O) | 14 (E), 15 (O) | 16 (E), 17 (O) |
| 5 | 10 | 11 | 11 | 12 | 20 (E), 21 (O) | 22 (E), 23 (O) | 18 (E), 19 (O) | 20 (E), 21 (O) |
| 6 | 12 | 13 | 13 | 14 | 24 (E), 25 (O) | 26 (E), 27 (O) | 22 (E), 23 (O) | 24 (E), 25 (O) |
| 7 | 14 | 15 | 15 | 16 | 28 (E), 29 (O) | 30 (E), 31 (O) | 26 (E), 27 (O) | 28 (E), 29 (O) |
| 8 | 16 | 17 | 17 | 18 | 32 (E), 33 (O) | 34 (E), 35 (O) | 30 (E), 31 (O) | 32 (E), 33 (O) |
| 9 | 18 | 19 | 19 | 20 | 36 (E), 37 (O) | 38 (E), 39 (O) | 34 (E), 35 (O) | 36 (E), 37 (O) |
| 10 | 20 | 21 | 21 | 22 | 40 (E), 41 (O) | 42 (E), 43 (O) | 38 (E), 39 (O) | 40 (E), 41 (O) |
| 11 | 22 | 23 | 23 | 24 | 44 (E), 45 (O) | 46 (E), 47 (O) | 42 (E), 43 (O) | 44 (E), 45 (O) |
| 12 | 24 | 25 | 25 | 26 | 48 (E), 49 (O) | 50 (E), 51 (O) | 46 (E), 47 (O) | 48 (E), 49 (O) |
| 13 | 26 | 27 | 27 | 28 | 52 (E), 53 (O) | 54 (E), 55 (O) | 50 (E), 51 (O) | 52 (E), 53 (O) |
| 14 | 28 | 29 | 29 | 30 | 56 (E), 57 (O) | 58 (E), 59 (O) | 54 (E), 55 (O) | 56 (E), 57 (O) |
| 15 | 30 | 31 | 31 | 32 | 60 (E), 61 (O) | 62 (E), 63 (O) | 58 (E), 59 (O) | 60 (E), 61 (O) |

Legend: (E) = Even transaction buffer, (O) = Odd transaction buffer

PIC24FJ256DA210 FAMILY

[查询PIC24FJ256DA106供应商](#)

REGISTER 18-1: **BDnSTAT: BUFFER DESCRIPTOR n STATUS REGISTER PROTOTYPE, USB MODE (BD0STAT THROUGH BD63STAT)**

| | | | | | | | |
|--------|-------|------------|------------|------------|------------|------------|------------|
| R/W-x | R/W-x | R/W-x, HSC | R/W-x, HSC | R/W-x, HSC | R/W-x, HSC | R/W-x, HSC | R/W-x, HSC |
| UOWN | DTS | PID3 | PID2 | PID1 | PID0 | BC9 | BC8 |
| bit 15 | | | | | | | bit 8 |

| | | | | | | | |
|------------|------------|------------|------------|------------|------------|------------|------------|
| R/W-x, HSC | R/W-x, HSC | R/W-x, HSC | R/W-x, HSC | R/W-x, HSC | R/W-x, HSC | R/W-x, HSC | R/W-x, HSC |
| BC7 | BC6 | BC5 | BC4 | BC3 | BC2 | BC1 | BC0 |
| bit 7 | | | | | | | bit 0 |

| | | | |
|-------------------|---------------------------------------|------------------------------------|--------------------|
| Legend: | HSC = Hardware Settable/Clearable bit | | |
| R = Readable bit | W = Writable bit | U = Unimplemented bit, read as '0' | |
| -n = Value at POR | '1' = Bit is set | '0' = Bit is cleared | x = Bit is unknown |

- bit 15 **UOWN:** USB Own bit
 1 = The USB module owns the BD and its corresponding buffer; the CPU must not modify the BD or the buffer
- bit 14 **DTS:** Data Toggle Packet bit
 1 = Data 1 packet
 0 = Data 0 packet
- bit 13-10 **PID<3:0>:** Packet Identifier bits (written by the USB module)
In Device mode:
 Represents the PID of the received token during the last transfer.
In Host mode:
 Represents the last returned PID or the transfer status indicator.
- bit 9-0 **BC<9:0>:** Byte Count bits
 This represents the number of bytes to be transmitted or the maximum number of bytes to be received during a transfer. Upon completion, the byte count is updated by the USB module with the actual number of bytes transmitted or received.

PIC24FJ256DA210 FAMILY

[查询PIC24FJ256DA106供应商](#)

REGISTER 18-2: BDNSTAT: BUFFER DESCRIPTOR n STATUS REGISTER PROTOTYPE, CPU MODE (BD0STAT THROUGH BD63STAT)

| | | | | | | | |
|--------|--------------------|----------|----------|-------|--------|------------|------------|
| R/W-x | R/W-x | r-0 | r-0 | R/W-x | R/W-x | R/W-x, HSC | R/W-x, HSC |
| UOWN | DTS ⁽¹⁾ | Reserved | Reserved | DTSEN | BSTALL | BC9 | BC8 |
| bit 15 | | | | | | bit 8 | |

| | | | | | | | |
|------------|------------|------------|------------|------------|------------|------------|------------|
| R/W-x, HSC | R/W-x, HSC | R/W-x, HSC | R/W-x, HSC | R/W-x, HSC | R/W-x, HSC | R/W-x, HSC | R/W-x, HSC |
| BC7 | BC6 | BC5 | BC4 | BC3 | BC2 | BC1 | BC0 |
| bit 7 | | | | | | bit 0 | |

| | | |
|-------------------|---------------------------------------|------------------------------------|
| Legend: | HSC = Hardware Settable/Clearable bit | r = Reserved bit |
| R = Readable bit | W = Writable bit | U = Unimplemented bit, read as '0' |
| -n = Value at POR | '1' = Bit is set | 'r' = Reserved bit |
| | | x = Bit is unknown |

- bit 15 **UOWN:** USB Own bit
0 = The microcontroller core owns the BD and its corresponding buffer; the USB module ignores all other fields in the BD
- bit 14 **DTS:** Data Toggle Packet bit⁽¹⁾
1 = Data 1 packet
0 = Data 0 packet
- bit 13-12 **Reserved:** Maintain as '0'
- bit 11 **DTSEN:** Data Toggle Synchronization Enable bit
1 = Data toggle synchronization is enabled; data packets with incorrect sync value will be ignored
0 = No data toggle synchronization is performed
- bit 10 **BSTALL:** Buffer Stall Enable bit
1 = Buffer STALL enabled; STALL handshake issued if a token is received that would use the BD in the given location (UOWN bit remains set, BD value is unchanged); corresponding EPSTALL bit will get set on any STALL handshake
0 = Buffer STALL disabled
- bit 9-0 **BC<9:0>:** Byte Count bits
This represents the number of bytes to be transmitted or the maximum number of bytes to be received during a transfer. Upon completion, the byte count is updated by the USB module with the actual number of bytes transmitted or received.

Note 1: This bit is ignored unless DTSEN = 1.

PIC24FJ256DA210 FAMILY

[查询PIC24FJ256DA106供应商](#)

18.3 USB Interrupts

The USB OTG module has many conditions that can be configured to cause an interrupt. All interrupt sources use the same interrupt vector.

Figure 18-9 shows the interrupt logic for the USB module. There are two layers of interrupt registers in the USB module. The top level consists of overall USB status interrupts; these are enabled and flagged in the U1IE and U1IR registers, respectively. The second

level consists of USB error conditions, which are enabled and flagged in the U1EIR and U1EIE registers. An interrupt condition in any of these triggers a USB Error Interrupt Flag (UERRIF) in the top level.

Interrupts may be used to trap routine events in a USB transaction. Figure 18-10 provides some common events within a USB frame and their corresponding interrupts.

FIGURE 18-9: USB OTG INTERRUPT FUNNEL

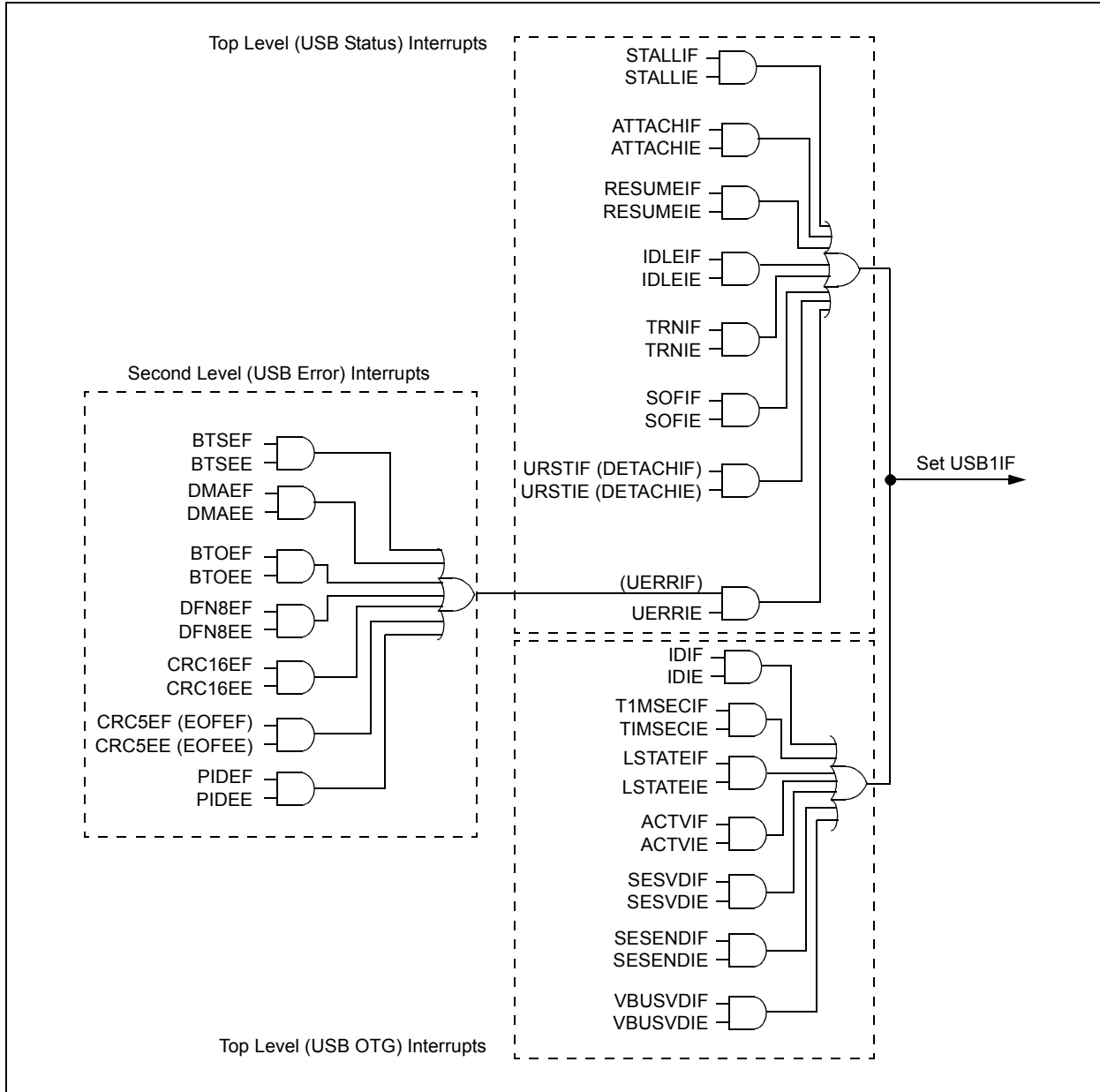

PIC24FJ256DA210 FAMILY

[查询PIC24FJ256DA106供应商](#)

18.3.1 CLEARING USB OTG INTERRUPTS

Unlike device level interrupts, the USB OTG interrupt status flags are not freely writable in software. All USB OTG flag bits are implemented as hardware set only bits. Additionally, these bits can only be cleared in

software by writing a '1' to their locations (i.e., performing a MOV type instruction). Writing a '0' to a flag bit (i.e., a BCLR instruction) has no effect.

Note: Throughout this data sheet, a bit that can only be cleared by writing a '1' to its location is referred to as "Write 1 to clear". In register descriptions, this function is indicated by the descriptor, "K".

FIGURE 18-10: EXAMPLE OF A USB TRANSACTION AND INTERRUPT EVENTS

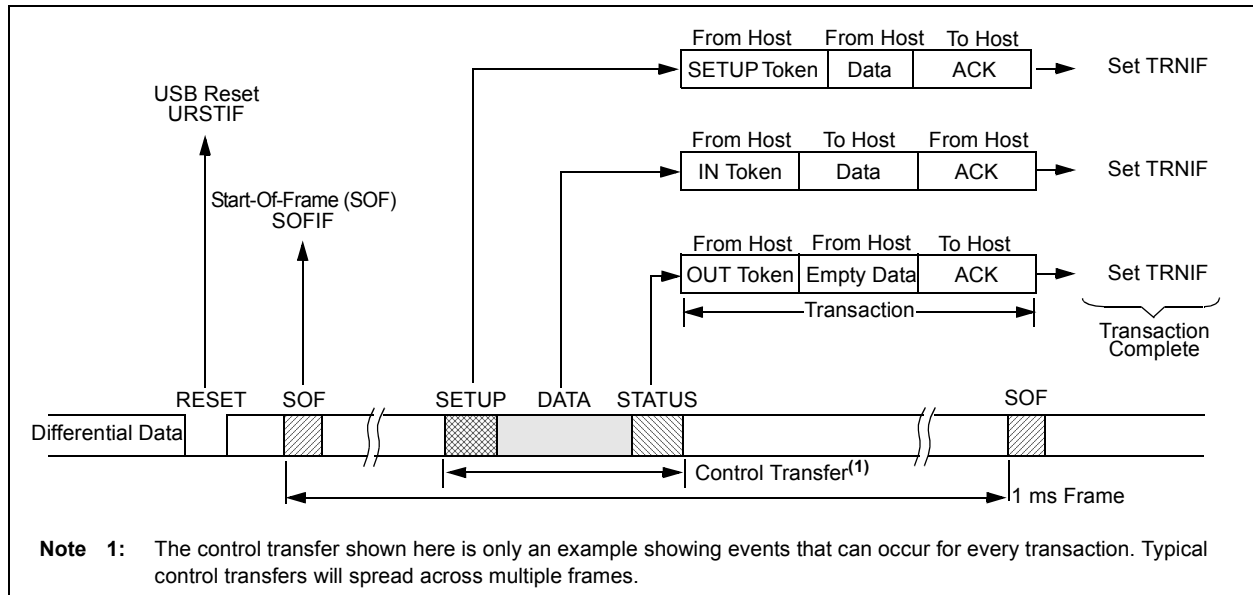

18.4 Device Mode Operation

The following section describes how to perform a common Device mode task. In Device mode, USB transfers are performed at the transfer level. The USB module automatically performs the status phase of the transfer.

18.4.1 ENABLING DEVICE MODE

1. Reset the Ping-Pong Buffer Pointers by setting, then clearing, the Ping-Pong Buffer Reset bit, PPBRST (U1CON<1>).
2. Disable all interrupts (U1IE and U1EIE = 00h).
3. Clear any existing interrupt flags by writing FFh to U1IR and U1EIR.
4. Verify that VBUS is present (non OTG devices only).

5. Enable the USB module by setting the USBEN bit (U1CON<0>).
6. Set the OTGEN bit (U1OTGCON<2>) to enable OTG operation.
7. Enable the endpoint zero buffer to receive the first setup packet by setting the EPRXEN and EPHSHK bits for Endpoint 0 (U1EP0<3,0> = 1).
8. Power up the USB module by setting the USBPWR bit (U1PWRC<0>).
9. Enable the D+ pull-up resistor to signal an attach by setting DPPULUP bit (U1OTGCON<7>).

PIC24FJ256DA210 FAMILY

[查询PIC24FJ256DA106供应商](#)

18.4.2 RECEIVING AN IN TOKEN IN DEVICE MODE

1. Attach to a USB host and enumerate as described in “*Chapter 9 of the USB 2.0 Specification*”.
2. Create a data buffer and populate it with the data to send to the host.
3. In the appropriate (even or odd) TX BD for the desired endpoint:
 - a) Set up the status register (BDnSTAT) with the correct data toggle (DATA0/1) value and the byte count of the data buffer.
 - b) Set up the address register (BDnADR) with the starting address of the data buffer.
 - c) Set the UOWN bit of the status register to ‘1’.
4. When the USB module receives an IN token, it automatically transmits the data in the buffer. Upon completion, the module updates the status register (BDnSTAT) and sets the Transfer Complete Interrupt Flag, TRNIF (U1IR<3>).

18.4.3 RECEIVING AN OUT TOKEN IN DEVICE MODE

1. Attach to a USB host and enumerate as described in “*Chapter 9 of the USB 2.0 Specification*”.
2. Create a data buffer with the amount of data you are expecting from the host.
3. In the appropriate (even or odd) TX BD for the desired endpoint:
 - a) Set up the status register (BDnSTAT) with the correct data toggle (DATA0/1) value and the byte count of the data buffer.
 - b) Set up the address register (BDnADR) with the starting address of the data buffer.
 - c) Set the UOWN bit of the status register to ‘1’.
4. When the USB module receives an OUT token, it automatically receives the data sent by the host to the buffer. Upon completion, the module updates the status register (BDnSTAT) and sets the Transfer Complete Interrupt Flag, TRNIF (U1IR<3>).

18.5 Host Mode Operation

The following sections describe how to perform common Host mode tasks. In Host mode, USB transfers are invoked explicitly by the host software. The host software is responsible for the Acknowledge portion of the transfer. Also, all transfers are performed using the Endpoint 0 Control register (U1EP0) and Buffer Descriptors.

18.5.1 ENABLE HOST MODE AND DISCOVER A CONNECTED DEVICE

1. Enable Host mode by setting the HOSTEN bit (U1CON<3>). This causes the Host mode control bits in other USB OTG registers to become available.
2. Enable the D+ and D- pull-down resistors by setting the DPPULDWN and DMPULDWN bits (U1OTGCON<5:4>). Disable the D+ and D-pull-up resistors by clearing the DPPULUP and DMPULUP bits (U1OTGCON<7:6>).
3. At this point, SOF generation begins with the SOF counter loaded with 12,000. Eliminate noise on the USB by clearing the SOFEN bit (U1CON<0>) to disable Start-Of-Frame packet generation.
4. Enable the device attached interrupt by setting the ATTACHIE bit (U1IE<6>).
5. Wait for the device attached interrupt (U1IR<6> = 1). This is signaled by the USB device changing the state of D+ or D- from ‘0’ to ‘1’ (SE0 to J state). After it occurs, wait 100 ms for the device power to stabilize.
6. Check the state of the JSTATE and SE0 bits in U1CON. If the JSTATE bit (U1CON<7>) is ‘0’, the connecting device is low speed. If the connecting device is low speed, set the low LSPDEN and LSPD bits (U1ADDR<7> and U1EP0<7>) to enable low-speed operation.
7. Reset the USB device by setting the USBRST bit (U1CON<4>) for at least 50 ms, sending Reset signaling on the bus. After 50 ms, terminate the Reset by clearing USBRST.
8. In order to keep the connected device from going into suspend, enable the SOF packet generation by setting the SOFEN bit.
9. Wait 10 ms for the device to recover from Reset.
10. Perform enumeration as described by “*Chapter 9 of the USB 2.0 Specification*”.

PIC24FJ256DA210 FAMILY

[查询PIC24FJ256DA106供应商](#)

18.5.2 COMPLETE A CONTROL TRANSACTION TO A CONNECTED DEVICE

1. Follow the procedure described in **Section 18.5.1 “Enable Host Mode and Discover a Connected Device”** to discover a device.
2. Set up the Endpoint Control register for bidirectional control transfers by writing 0Dh to U1EP0 (this sets the EPCONDIS, EPTXEN and EPHSHK bits).
3. Place a copy of the device framework setup command in a memory buffer. See “*Chapter 9 of the USB 2.0 Specification*” for information on the device framework command set.
4. Initialize the Buffer Descriptor (BD) for the current (even or odd) TX EP0 to transfer the eight bytes of command data for a device framework command (i.e., GET_DEVICE_DESCRIPTOR):
 - a) Set the BD data buffer address (BD0ADR) to the starting address of the 8-byte memory buffer containing the command.
 - b) Write 8008h to BD0STAT (this sets the UOWN bit and sets a byte count of 8).
5. Set the USB device address of the target device in the address register (U1ADDR<6:0>). After a USB bus Reset, the device USB address will be zero. After enumeration, it will be set to another value between 1 and 127.
6. Write D0h to U1TOK; this is a SETUP token to Endpoint 0, the target device’s default control pipe. This initiates a SETUP token on the bus, followed by a data packet. The device handshake is returned in the PID field of BD0STAT after the packets are complete. When the USB module updates BD0STAT, a transfer done interrupt is asserted (the TRNIF flag is set). This completes the setup phase of the setup transaction as referenced in “*Chapter 9 of the USB Specification*”.
7. To initiate the data phase of the setup transaction (i.e., get the data for the GET_DEVICE_DESCRIPTOR command), set up a buffer in memory to store the received data.
8. Initialize the current (even or odd) RX or TX (RX for IN, TX for OUT) EP0 BD to transfer the data.
 - a) Write C040h to BD0STAT. This sets the UOWN, configures Data Toggle (DTS) to DATA1 and sets the byte count to the length of the data buffer (64 or 40h in this case).
 - b) Set BD0ADR to the starting address of the data buffer.
9. Write the Token register with the appropriate IN or OUT token to Endpoint 0, the target device’s default control pipe (e.g., write 90h to U1TOK for an IN token for a GET_DEVICE_DESCRIPTOR command). This initiates an IN token on the bus followed by a data packet from the device to the host. When the data packet completes, the BD0STAT is written and a transfer done interrupt is asserted (the TRNIF flag is set). For control transfers with a single packet data phase, this completes the data phase of the setup transaction as referenced in “*Chapter 9 of the USB Specification*”. If more data needs to be transferred, return to step 8.
10. To initiate the status phase of the setup transaction, set up a buffer in memory to receive or send the zero length status phase data packet.
11. Initialize the current (even or odd) TX EP0 BD to transfer the status data:
 - a) Set the BDT buffer address field to the start address of the data buffer.
 - b) Write 8000h to BD0STAT (set UOWN bit, configure DTS to DATA0 and set byte count to 0).
12. Write the Token register with the appropriate IN or OUT token to Endpoint 0, the target device’s default control pipe (e.g., write 01h to U1TOK for an OUT token for a GET_DEVICE_DESCRIPTOR command). This initiates an OUT token on the bus followed by a zero length data packet from the host to the device. When the data packet completes, the BD is updated with the handshake from the device and a transfer done interrupt is asserted (the TRNIF flag is set). This completes the status phase of the setup transaction as described in “*Chapter 9 of the USB Specification*”.

Note: Only one control transaction can be performed per frame.

PIC24FJ256DA210 FAMILY

[查询PIC24FJ256DA106供应商](#)

18.5.3 SEND A FULL-SPEED BULK DATA TRANSFER TO A TARGET DEVICE

1. Follow the procedure described in **Section 18.5.1 “Enable Host Mode and Discover a Connected Device”** and **Section 18.5.2 “Complete a Control Transaction to a Connected Device”** to discover and configure a device.
2. To enable transmit and receive transfers with handshaking enabled, write 1Dh to U1EP0. If the target device is a low-speed device, also set the LSPD (U1EP0<7>) bit. If you want the hardware to automatically retry indefinitely if the target device asserts a NAK on the transfer, clear the Retry Disable bit, RETRYDIS (U1EP0<6>).
3. Set up the BD for the current (even or odd) TX EP0 to transfer up to 64 bytes.
4. Set the USB device address of the target device in the address register (U1ADDR<6:0>).
5. Write an OUT token to the desired endpoint to U1TOK. This triggers the module's transmit state machines to begin transmitting the token and the data.
6. Wait for the Transfer Done Interrupt Flag, TRNIF. This indicates that the BD has been released back to the microprocessor and the transfer has completed. If the retry disable bit is set, the handshake (ACK, NAK, STALL or ERROR (0Fh)) is returned in the BD PID field. If a STALL interrupt occurs, the pending packet must be dequeued and the error condition in the target device cleared. If a detach interrupt occurs (SE0 for more than 2.5 μ s), then the target has detached (U1IR<0> is set).
7. Once the transfer done interrupt occurs (TRNIF is set), the BD can be examined and the next data packet queued by returning to step 2.

Note: USB speed, transceiver and pull-ups should only be configured during the module setup phase. It is not recommended to change these settings while the module is enabled.

18.6 OTG Operation

18.6.1 SESSION REQUEST PROTOCOL (SRP)

An OTG A-device may decide to power down the VBUS supply when it is not using the USB link through the Session Request Protocol (SRP). Software may do this by clearing VBUSON (U1OTGCON<3>). When the VBUS supply is powered down, the A-device is said to have ended a USB session.

An OTG A-device or embedded host may repower the VBUS supply at any time (initiate a new session). An OTG B-device may also request that the OTG A-device repower the VBUS supply (initiate a new session). This is accomplished via Session Request Protocol (SRP).

Prior to requesting a new session, the B-device must first check that the previous session has definitely ended. To do this, the B-device must check for two conditions:

1. VBUS supply is below the session valid voltage, and
2. Both D+ and D- have been low for at least 2 ms.

The B-device will be notified of Condition 1 by the SESENDIF (U1OTGIR<2>) interrupt. Software will have to manually check for Condition 2.

Note: When the A-device powers down the VBUS supply, the B-device must disconnect its pull-up resistor from power. If the device is self-powered, it can do this by clearing DPPULUP (U1OTGCON<7>) and DMPULUP (U1OTGCON<6>).

The B-device may aid in achieving Condition 1 by discharging the VBUS supply through a resistor. Software may do this by setting VBUSDIS (U1OTGCON<0>).

After these initial conditions are met, the B-device may begin requesting the new session. The B-device begins by pulsing the D+ data line. Software should do this by setting DPPULUP (U1OTGCON<7>). The data line should be held high for 5 to 10 ms.

The B-device then proceeds by pulsing the VBUS supply. Software should do this by setting PUVBUS (U1CNFG2<4>). When an A-device detects SRP signaling (either via the ATTACHIF (U1IR<6>) interrupt or via the SESVDIF (U1OTGIR<3>) interrupt), the A-device must restore the VBUS supply by either setting VBUSON (U1OTGCON<3>) or by setting the I/O port controlling the external power source.

The B-device should not monitor the state of the VBUS supply while performing VBUS supply pulsing. When the B-device does detect that the VBUS supply has been restored (via the SESVDIF (U1OTGIR<3>) interrupt), the B-device must reconnect to the USB link by pulling up D+ or D- (via the DPPULUP or DMPULUP).

The A-device must complete the SRP by driving USB Reset signaling.

PIC24FJ256DA210 FAMILY

[查询PIC24FJ256DA106供应商](#)

18.6.2 HOST NEGOTIATION PROTOCOL (HNP)

In USB OTG applications, a Dual Role Device (DRD) is a device that is capable of being either a host or a peripheral. Any OTG DRD must support Host Negotiation Protocol (HNP).

HNP allows an OTG B-device to temporarily become the USB host. The A-device must first enable the B-device to follow HNP. Refer to the “*On-The-Go Supplement to the USB 2.0 Specification*” for more information regarding HNP. HNP may only be initiated at full speed.

After being enabled for HNP by the A-device, the B-device requests being the host any time that the USB link is in suspend state, by simply indicating a disconnect. This can be done in software by clearing DPPULUP and DMPULUP. When the A-device detects the disconnect condition (via the URSTIF (U1IR<0>) interrupt), the A-device may allow the B-device to take over as host. The A-device does this by signaling connect as a full-speed function. Software may accomplish this by setting DPPULUP.

If the A-device responds instead with resume signaling, the A-device remains as host. When the B-device detects the connect condition (via ATTACHIF (U1IR<6>)), the B-device becomes host. The B-device drives Reset signaling prior to using the bus.

When the B-device has finished in its role as host, it stops all bus activity and turns on its D+ pull-up resistor by setting DPPULUP. When the A-device detects a suspend condition (Idle for 3 ms), the A-device turns off its D+ pull-up. The A-device may also power-down the VBUS supply to end the session. When the A-device detects the connect condition (via ATTACHIF), the A-device resumes host operation and drives Reset signaling.

18.6.3 EXTERNAL VBUS COMPARATORS

The external VBUS comparator option is enabled by setting the UVCMPDIS bit (U1CNFG2<1>). This disables the internal VBUS comparators, removing the need to attach VBUS to the microcontroller’s VBUS pin.

The external comparator interface uses either the VCOMPST1 and VCOMPST2 pins, or the VBUSVLD, SESSVLD and SESSEND pins, based upon the setting of the UVCMPSEL bit (U1CNFG2<5>). These pins are digital inputs and should be set in the following patterns (see Table 18-3), based on the current level of the VBUS voltage.

TABLE 18-3: EXTERNAL VBUS COMPARATOR STATES

| If UVCMPSEL = 0 | | | |
|-----------------|----------|----------------------------------|----------------------------------|
| VCOMPST1 | VCOMPST2 | Bus Condition | |
| 0 | 0 | VBUS < VB_SESS_END | |
| 1 | 0 | VB_SESS_END < VBUS < VA_SESS_VLD | |
| 0 | 1 | VA_SESS_VLD < VBUS < VA_VBUS_VLD | |
| 1 | 1 | VBUS > VBUS_VLD | |
| If UVCMPSEL = 1 | | | |
| VBUSVLD | SESSVLD | SESSEND | Bus Condition |
| 0 | 0 | 1 | VBUS < VB_SESS_END |
| 0 | 0 | 0 | VB_SESS_END < VBUS < VA_SESS_VLD |
| 0 | 1 | 0 | VA_SESS_VLD < VBUS < VA_VBUS_VLD |
| 1 | 1 | 0 | VBUS > VBUS_VLD |

PIC24FJ256DA210 FAMILY

[查询PIC24FJ256DA106供应商](#)

18.7 USB OTG Module Registers

There are a total of 37 memory mapped registers associated with the USB OTG module. They can be divided into four general categories:

- USB OTG Module Control (12)
- USB Interrupt (7)
- USB Endpoint Management (16)
- USB VBus Power Control (2)

This total does not include the (up to) 128 BD registers in the BDT. Their prototypes, described in Register 18-1 and Register 18-2, are shown separately in **Section 18.2 “USB Buffer Descriptors and the BDT”**.

With the exception of U1PWMCON and U1PWMRRS, all USB OTG registers are implemented in the Least Significant Byte of the register. Bits in the upper byte are unimplemented and have no function. Note that some registers are instantiated only in Host mode, while other registers have different bit instantiations and functions in Device and Host modes.

The registers described in the following sections are those that have bits with specific control and configuration features. The following registers are used for data or address values only:

- U1BDTP1: Specifies the 256-word page in data RAM used for the BDT; 8-bit value with bit 0 fixed as '0' for boundary alignment.
- U1FRML and U1FRMH: Contains the 11-bit byte counter for the current data frame.
- U1PWMRRS: Contains the 8-bit value for PWM duty cycle bits<15:8> and PWM period bits<7:0> for the VBUS boost assist PWM module.

PIC24FJ256DA210 FAMILY

[查询PIC24FJ256DA106供应商](#)

18.7.1 USB OTG MODULE CONTROL REGISTERS

REGISTER 18-3: U1OTGSTAT: USB OTG STATUS REGISTER (HOST MODE ONLY)

| | | | | | | | |
|--------|-----|-----|-----|-----|-----|-------|-----|
| U-0 | U-0 | U-0 | U-0 | U-0 | U-0 | U-0 | U-0 |
| — | — | — | — | — | — | — | — |
| bit 15 | | | | | | bit 8 | |

| | | | | | | | |
|----------|-----|----------|-----|----------|----------|-------|----------|
| R-0, HSC | U-0 | R-0, HSC | U-0 | R-0, HSC | R-0, HSC | U-0 | R-0, HSC |
| ID | — | LSTATE | — | SESVD | SESEND | — | VBUSVD |
| bit 7 | | | | | | bit 0 | |

| | |
|-------------------|---------------------------------------|
| Legend: | U = Unimplemented bit, read as '0' |
| R = Readable bit | W = Writable bit |
| -n = Value at POR | '1' = Bit is set |
| | '0' = Bit is cleared |
| | x = Bit is unknown |
| | HSC = Hardware Settable/Clearable bit |

bit 15-8 **Unimplemented:** Read as '0'

bit 7 **ID:** ID Pin State Indicator bit

- 1 = No plug is attached, or a type B cable has been plugged into the USB receptacle
- 0 = A type A plug has been plugged into the USB receptacle

bit 6 **Unimplemented:** Read as '0'

bit 5 **LSTATE:** Line State Stable Indicator bit

- 1 = The USB line state (as defined by SE0 and JSTATE) has been stable for the previous 1 ms
- 0 = The USB line state has not been stable for the previous 1 ms

bit 4 **Unimplemented:** Read as '0'

bit 3 **SESVD:** Session Valid Indicator bit

- 1 = The VBUS voltage is above VA_SESS_VLD (as defined in the USB OTG Specification) on the A or B-device
- 0 = The VBUS voltage is below VA_SESS_VLD on the A or B-device

bit 2 **SESEND:** B Session End Indicator bit

- 1 = The VBUS voltage is below VB_SESS_END (as defined in the USB OTG Specification) on the B-device
- 0 = The VBUS voltage is above VB_SESS_END on the B-device

bit 1 **Unimplemented:** Read as '0'

bit 0 **VBUSVD:** A VBUS Valid Indicator bit

- 1 = The VBUS voltage is above VA_VBUS_VLD (as defined in the USB OTG Specification) on the A-device
- 0 = The VBUS voltage is below VA_VBUS_VLD on the A-device

PIC24FJ256DA210 FAMILY

[查询PIC24FJ256DA106供应商](#)

REGISTER 18-4: U1OTGCON: USB ON-THE-GO CONTROL REGISTER

| | | | | | | | |
|--------|-----|-----|-----|-----|-----|-----|-------|
| U-0 | U-0 | U-0 | U-0 | U-0 | U-0 | U-0 | U-0 |
| — | — | — | — | — | — | — | — |
| bit 15 | | | | | | | bit 8 |

| | | | | | | | |
|---------|---------|-------------------------|-------------------------|-----------------------|----------------------|------------------------|------------------------|
| R/W-0 | R/W-0 | R/W-0 | R/W-0 | R/W-0 | R/W-0 | R/W-0 | R/W-0 |
| DPPULUP | DMPULUP | DPPULDWN ⁽¹⁾ | DMPULDWN ⁽¹⁾ | VBUSON ⁽¹⁾ | OTGEN ⁽¹⁾ | VBUSCHG ⁽¹⁾ | VBUSDIS ⁽¹⁾ |
| bit 7 | | | | | | | bit 0 |

Legend:

R = Readable bit W = Writable bit U = Unimplemented bit, read as '0'
 -n = Value at POR '1' = Bit is set '0' = Bit is cleared x = Bit is unknown

- bit 15-8 **Unimplemented:** Read as '0'
- bit 7 **DPPULUP:** D+ Pull-up Enable bit
 1 = D+ data line pull-up resistor is enabled
 0 = D+ data line pull-up resistor is disabled
- bit 6 **DMPULUP:** D- Pull-up Enable bit
 1 = D- data line pull-up resistor is enabled
 0 = D- data line pull-up resistor is disabled
- bit 5 **DPPULDWN:** D+ Pull-Down Enable bit⁽¹⁾
 1 = D+ data line pull-down resistor is enabled
 0 = D+ data line pull-down resistor is disabled
- bit 4 **DMPULDWN:** D- Pull-Down Enable bit⁽¹⁾
 1 = D- data line pull-down resistor is enabled
 0 = D- data line pull-down resistor is disabled
- bit 3 **VBUSON:** VBUS Power-on bit⁽¹⁾
 1 = VBUS line is powered
 0 = VBUS line is not powered
- bit 2 **OTGEN:** OTG Features Enable bit⁽¹⁾
 1 = USB OTG is enabled; all D+/D- pull-up and pull-down bits are enabled
 0 = USB OTG is disabled; D+/D- pull-up and pull-down bits are controlled in hardware by the settings of the HOSTEN and USBEN (U1CON<3,0>) bits
- bit 1 **VBUSCHG:** VBUS Charge Select bit⁽¹⁾
 1 = VBUS line is set to charge to 3.3V
 0 = VBUS line is set to charge to 5V
- bit 0 **VBUSDIS:** VBUS Discharge Enable bit⁽¹⁾
 1 = VBUS line is discharged through a resistor
 0 = VBUS line is not discharged

Note 1: These bits are only used in Host mode; do not use in Device mode.

PIC24FJ256DA210 FAMILY

[查询PIC24FJ256DA106供应商](#)

REGISTER 18-5: U1PWRC: USB POWER CONTROL REGISTER

| | | | | | | | |
|--------|-----|-----|-----|-----|-----|-----|-------|
| U-0 | U-0 | U-0 | U-0 | U-0 | U-0 | U-0 | U-0 |
| — | — | — | — | — | — | — | — |
| bit 15 | | | | | | | bit 8 |

| | | | | | | | |
|-----------|-----|-----|---------|-----|-----|-----------|--------|
| R/W-0, HS | U-0 | U-0 | R/W-0 | U-0 | U-0 | R/W-0, HC | R/W-0 |
| UACTPND | — | — | USLPGRD | — | — | USUSPND | USBPWR |
| bit 7 | | | | | | | bit 0 |

| | | |
|-------------------|----------------------------|------------------------------------|
| Legend: | HS = Hardware Settable bit | HC = Hardware Clearable bit |
| R = Readable bit | W = Writable bit | U = Unimplemented bit, read as '0' |
| -n = Value at POR | '1' = Bit is set | '0' = Bit is cleared |
| | | x = Bit is unknown |

bit 15-8 **Unimplemented:** Read as '0'

bit 7 **UACTPND:** USB Activity Pending bit

1 = Module should not be suspended at the moment (requires the USLPGRD bit to be set)

0 = Module may be suspended or powered down

bit 6-5 **Unimplemented:** Read as '0'

bit 4 **USLPGRD:** Sleep/Suspend Guard bit

1 = Indicate to the USB module that it is about to be suspended or powered down

0 = No suspend

bit 3-2 **Unimplemented:** Read as '0'

bit 1 **USUSPND:** USB Suspend Mode Enable bit

1 = USB OTG module is in Suspend mode; USB clock is gated and the transceiver is placed in a low-power state

0 = Normal USB OTG operation

bit 0 **USBPWR:** USB Operation Enable bit

1 = USB OTG module is enabled

0 = USB OTG module is disabled⁽¹⁾

Note 1: Do not clear this bit unless the HOSTEN, USBEN and OTGEN bits (U1CON<3,0> and U1OTGCON<2>) are all cleared.

PIC24FJ256DA210 FAMILY

[查询PIC24FJ256DA106供应商](#)

REGISTER 18-6: U1STAT: USB STATUS REGISTER

| | | | | | | | |
|--------|-----|-----|-----|-----|-----|-----|-------|
| U-0 | U-0 | U-0 | U-0 | U-0 | U-0 | U-0 | U-0 |
| — | — | — | — | — | — | — | — |
| bit 15 | | | | | | | bit 8 |

| | | | | | | | |
|----------|----------|----------|----------|----------|---------------------|-----|-------|
| R-0, HSC | R-0, HSC | R-0, HSC | R-0, HSC | R-0, HSC | R-0, HSC | U-0 | U-0 |
| ENDPT3 | ENDPT2 | ENDPT1 | ENDPT0 | DIR | PPBI ⁽¹⁾ | — | — |
| bit 7 | | | | | | | bit 0 |

| | | | |
|-------------------|------------------------------------|---------------------------------------|--------------------|
| Legend: | U = Unimplemented bit, read as '0' | | |
| R = Readable bit | W = Writable bit | HSC = Hardware Settable/Clearable bit | |
| -n = Value at POR | '1' = Bit is set | '0' = Bit is cleared | x = Bit is unknown |

- bit 15-8 **Unimplemented:** Read as '0'
- bit 7-4 **ENDPT<3:0>:** Number of the Last Endpoint Activity bits
(Represents the number of the BDT updated by the last USB transfer.)
 - 1111 = Endpoint 15
 - 1110 = Endpoint 14
 - .
 - .
 - .
 - 0001 = Endpoint 1
 - 0000 = Endpoint 0
- bit 3 **DIR:** Last BD Direction Indicator bit
 - 1 = The last transaction was a transmit transfer (TX)
 - 0 = The last transaction was a receive transfer (RX)
- bit 2 **PPBI:** Ping-Pong BD Pointer Indicator bit⁽¹⁾
 - 1 = The last transaction was to the odd BD bank
 - 0 = The last transaction was to the even BD bank
- bit 1-0 **Unimplemented:** Read as '0'

Note 1: This bit is only valid for endpoints with available even and odd BD registers.

PIC24FJ256DA210 FAMILY

[查询PIC24FJ256DA106供应商](#)

REGISTER 18-7: U1CON: USB CONTROL REGISTER (DEVICE MODE)

| | | | | | | | |
|--------|-----|-----|-----|-----|-----|-------|-----|
| U-0 | U-0 | U-0 | U-0 | U-0 | U-0 | U-0 | U-0 |
| — | — | — | — | — | — | — | — |
| bit 15 | | | | | | bit 8 | |

| | | | | | | | |
|-------|----------|--------|-----|--------|--------|--------|-------|
| U-0 | R-x, HSC | R/W-0 | U-0 | R/W-0 | R/W-0 | R/W-0 | R/W-0 |
| — | SE0 | PKTDIS | — | HOSTEN | RESUME | PPBRST | USBEN |
| bit 7 | | | | | | bit 0 | |

| | |
|-------------------|---------------------------------------|
| Legend: | U = Unimplemented bit, read as '0' |
| R = Readable bit | W = Writable bit |
| -n = Value at POR | '1' = Bit is set |
| | HSC = Hardware Settable/Clearable bit |
| | '0' = Bit is cleared |
| | x = Bit is unknown |

bit 15-7 **Unimplemented:** Read as '0'

bit 6 **SE0:** Live Single-Ended Zero Flag bit
 1 = Single-ended zero is active on the USB bus
 0 = No single-ended zero is detected

bit 5 **PKTDIS:** Packet Transfer Disable bit
 1 = SIE token and packet processing are disabled; automatically set when a SETUP token is received
 0 = SIE token and packet processing are enabled

bit 4 **Unimplemented:** Read as '0'

bit 3 **HOSTEN:** Host Mode Enable bit
 1 = USB host capability is enabled; pull-downs on D+ and D- are activated in hardware
 0 = USB host capability is disabled

bit 2 **RESUME:** Resume Signaling Enable bit
 1 = Resume signaling is activated
 0 = Resume signaling is disabled

bit 1 **PPBRST:** Ping-Pong Buffers Reset bit
 1 = Reset all Ping-Pong Buffer Pointers to the even BD banks
 0 = Ping-Pong Buffer Pointers are not reset

bit 0 **USBEN:** USB Module Enable bit
 1 = USB module and supporting circuitry are enabled (device attached); D+ pull-up is activated in hardware
 0 = USB module and supporting circuitry are disabled (device detached)

PIC24FJ256DA210 FAMILY

[查询PIC24FJ256DA106供应商](#)

REGISTER 18-8: UTCON: USB CONTROL REGISTER (HOST MODE ONLY)

| | | | | | | | |
|--------|-----|-----|-----|-----|-----|-----|-------|
| U-0 | U-0 | U-0 | U-0 | U-0 | U-0 | U-0 | U-0 |
| — | — | — | — | — | — | — | — |
| bit 15 | | | | | | | bit 8 |

| | | | | | | | |
|----------|----------|---------|--------|--------|--------|--------|-------|
| R-x, HSC | R-x, HSC | R/W-0 | R/W-0 | R/W-0 | R/W-0 | R/W-0 | R/W-0 |
| JSTATE | SE0 | TOKBUSY | USBRST | HOSTEN | RESUME | PPBRST | SOFEN |
| bit 7 | | | | | | | bit 0 |

| | | | |
|-------------------|------------------------------------|---------------------------------------|--------------------|
| Legend: | U = Unimplemented bit, read as '0' | | |
| R = Readable bit | W = Writable bit | HSC = Hardware Settable/Clearable bit | |
| -n = Value at POR | '1' = Bit is set | '0' = Bit is cleared | x = Bit is unknown |

- bit 15-8 **Unimplemented:** Read as '0'
- bit 7 **JSTATE:** Live Differential Receiver J State Flag bit
 1 = J state (differential '0' in low speed, differential '1' in full speed) is detected on the USB
 0 = No J state is detected
- bit 6 **SE0:** Live Single-Ended Zero Flag bit
 1 = Single-ended zero is active on the USB bus
 0 = No single-ended zero is detected
- bit 5 **TOKBUSY:** Token Busy Status bit
 1 = Token is being executed by the USB module in On-The-Go state
 0 = No token is being executed
- bit 4 **USBRST:** Module Reset bit
 1 = USB Reset has been generated; for software Reset, application must set this bit for 50 ms, then clear it
 0 = USB Reset is terminated
- bit 3 **HOSTEN:** Host Mode Enable bit
 1 = USB host capability is enabled; pull-downs on D+ and D- are activated in hardware
 0 = USB host capability is disabled
- bit 2 **RESUME:** Resume Signaling Enable bit
 1 = Resume signaling is activated; software must set bit for 10 ms and then clear to enable remote wake-up
 0 = Resume signaling is disabled
- bit 1 **PPBRST:** Ping-Pong Buffers Reset bit
 1 = Reset all Ping-Pong Buffer Pointers to the even BD banks
 0 = Ping-Pong Buffer Pointers are not reset
- bit 0 **SOFEN:** Start-Of-Frame Enable bit
 1 = Start-Of-Frame token is sent every one 1 ms
 0 = Start-Of-Frame token is disabled

PIC24FJ256DA210 FAMILY

[查询PIC24FJ256DA106供应商](#)

REGISTER 18-9: U1ADDR: USB ADDRESS REGISTER

| | | | | | | | |
|--------|-----|-----|-----|-----|-----|-----|-------|
| U-0 | U-0 | U-0 | U-0 | U-0 | U-0 | U-0 | U-0 |
| — | — | — | — | — | — | — | — |
| bit 15 | | | | | | | bit 8 |

| | | | | | | | |
|-----------------------|-------|-------|-------|-------|-------|-------|-------|
| R/W-0 | R/W-0 | R/W-0 | R/W-0 | R/W-0 | R/W-0 | R/W-0 | R/W-0 |
| LSPDEN ⁽¹⁾ | ADDR6 | ADDR5 | ADDR4 | ADDR3 | ADDR2 | ADDR1 | ADDR0 |
| bit 7 | | | | | | | bit 0 |

Legend:

R = Readable bit W = Writable bit U = Unimplemented bit, read as '0'
 -n = Value at POR '1' = Bit is set '0' = Bit is cleared x = Bit is unknown

- bit 15-8 **Unimplemented:** Read as '0'
- bit 7 **LSPDEN:** Low-Speed Enable Indicator bit⁽¹⁾
 1 = USB module operates at low speed
 0 = USB module operates at full speed
- bit 6-0 **ADDR<6:0>:** USB Device Address bits

Note 1: Host mode only. In Device mode, this bit is unimplemented and read as '0'.

REGISTER 18-10: U1TOK: USB TOKEN REGISTER (HOST MODE ONLY)

| | | | | | | | |
|--------|-----|-----|-----|-----|-----|-----|-------|
| U-0 | U-0 | U-0 | U-0 | U-0 | U-0 | U-0 | U-0 |
| — | — | — | — | — | — | — | — |
| bit 15 | | | | | | | bit 8 |

| | | | | | | | |
|-------|-------|-------|-------|-------|-------|-------|-------|
| R/W-0 | R/W-0 | R/W-0 | R/W-0 | R/W-0 | R/W-0 | R/W-0 | R/W-0 |
| PID3 | PID2 | PID1 | PID0 | EP3 | EP2 | EP1 | EP0 |
| bit 7 | | | | | | | bit 0 |

Legend:

R = Readable bit W = Writable bit U = Unimplemented bit, read as '0'
 -n = Value at POR '1' = Bit is set '0' = Bit is cleared x = Bit is unknown

- bit 15-8 **Unimplemented:** Read as '0'
- bit 7-4 **PID<3:0>:** Token Type Identifier bits
 1101 = SETUP (TX) token type transaction⁽¹⁾
 1001 = IN (RX) token type transaction⁽¹⁾
 0001 = OUT (TX) token type transaction⁽¹⁾
- bit 3-0 **EP<3:0>:** Token Command Endpoint Address bits
 This value must specify a valid endpoint on the attached device.

Note 1: All other combinations are reserved and are not to be used.

PIC24FJ256DA210 FAMILY

查询PIC24FJ256DA106供应商

REGISTER 18-11: U1SOF: USB OTG START-OF-TOKEN THRESHOLD REGISTER (HOST MODE ONLY)

| | | | | | | | |
|--------|-----|-----|-----|-----|-----|-----|-------|
| U-0 | U-0 | U-0 | U-0 | U-0 | U-0 | U-0 | U-0 |
| — | — | — | — | — | — | — | — |
| bit 15 | | | | | | | bit 8 |

| | | | | | | | |
|-------|-------|-------|-------|-------|-------|-------|-------|
| R/W-0 | R/W-0 | R/W-0 | R/W-0 | R/W-0 | R/W-0 | R/W-0 | R/W-0 |
| CNT7 | CNT6 | CNT5 | CNT4 | CNT3 | CNT2 | CNT1 | CNT0 |
| bit 7 | | | | | | | bit 0 |

Legend:

R = Readable bit W = Writable bit U = Unimplemented bit, read as '0'
 -n = Value at POR '1' = Bit is set '0' = Bit is cleared x = Bit is unknown

bit 15-8 **Unimplemented:** Read as '0'
 bit 7-0 **CNT<7:0>:** Start-Of-Frame Size bits
 Value represents 10 + (packet size of n bytes). For example:
 0100 1010 = 64-byte packet
 0010 1010 = 32-byte packet
 0001 0010 = 8-byte packet

REGISTER 18-12: U1CNFG1: USB CONFIGURATION REGISTER 1

| | | | | | | | |
|--------|-----|-----|-----|-----|-----|-----|-------|
| U-0 | U-0 | U-0 | U-0 | U-0 | U-0 | U-0 | U-0 |
| — | — | — | — | — | — | — | — |
| bit 15 | | | | | | | bit 8 |

| | | | | | | | |
|-------|-----------------------|-----|---------|-----|-----|-------|-------|
| R/W-0 | R/W-0 | U-0 | R/W-0 | U-0 | U-0 | R/W-0 | R/W-0 |
| UTEYE | UOEMON ⁽¹⁾ | — | USBSIDL | — | — | PPB1 | PPB0 |
| bit 7 | | | | | | | bit 0 |

Legend:

R = Readable bit W = Writable bit U = Unimplemented bit, read as '0'
 -n = Value at POR '1' = Bit is set '0' = Bit is cleared x = Bit is unknown

bit 15-8 **Unimplemented:** Read as '0'
 bit 7 **UTEYE:** USB Eye Pattern Test Enable bit
 1 = Eye pattern test is enabled
 0 = Eye pattern test is disabled
 bit 6 **UOEMON:** USB \overline{OE} Monitor Enable bit⁽¹⁾
 1 = \overline{OE} signal is active; it indicates intervals during which the D+/D- lines are driving
 0 = \overline{OE} signal is inactive
 bit 5 **Unimplemented:** Read as '0'
 bit 4 **USBSIDL:** USB OTG Stop in Idle Mode bit
 1 = Discontinue module operation when the device enters Idle mode
 0 = Continue module operation in Idle mode
 bit 3-2 **Unimplemented:** Read as '0'
 bit 1-0 **PPB<1:0>:** Ping-Pong Buffers Configuration bits
 11 = Even/Odd ping-pong buffers are enabled for Endpoints 1 to 15
 10 = Even/Odd ping-pong buffers are enabled for all endpoints
 01 = Even/Odd ping-pong buffers are enabled for OUT Endpoint 0
 00 = Even/Odd ping-pong buffers are disabled

Note 1: This bit is only active when the UTRDIS bit (U1CNFG2<0>) is set.

PIC24FJ256DA210 FAMILY

[查询PIC24FJ256DA106供应商](#)

REGISTER 18-13: U1CNFG2: USB CONFIGURATION REGISTER 2

| | | | | | | | |
|--------|-----|-----|-----|-----|-----|-----|-------|
| U-0 | U-0 | U-0 | U-0 | U-0 | U-0 | U-0 | U-0 |
| — | — | — | — | — | — | — | — |
| bit 15 | | | | | | | bit 8 |

| | | | | | | | |
|-------|-----|----------|--------|----------|-------------------------|-------------------------|-----------------------|
| U-0 | U-0 | R/W-0 | R/W-0 | R/W-0 | R/W-0 | R/W-0 | R/W-0 |
| — | — | UVCMPSEL | PUVBUS | EXTI2CEN | UVBUSDIS ⁽¹⁾ | UVCMPDIS ⁽¹⁾ | UTRDIS ⁽¹⁾ |
| bit 7 | | | | | | | bit 0 |

Legend:

R = Readable bit

W = Writable bit

U = Unimplemented bit, read as '0'

-n = Value at POR

'1' = Bit is set

'0' = Bit is cleared

x = Bit is unknown

bit 15-6 **Unimplemented:** Read as '0'

bit 5 **UVCMPSEL:** VBUS Comparator External Interface Selection bit
 1 = Use VBUSVLD, SESSVLD and SESSEND as comparator interface pins
 0 = Use VCOMPST1 and VCOMPST2 as comparator interface pins

bit 4 **PUVBUS:** VBUS Pull-Up Enable bit
 1 = Pull-up on VBUS pin is enabled
 0 = Pull-up on VBUS pin is disabled

bit 3 **EXTI2CEN:** I²C™ Interface For External Module Control Enable bit
 1 = External module(s) is controlled via the I²C™ interface
 0 = External module(s) controlled via the dedicated pins

bit 2 **UVBUSDIS:** On-Chip 5V Boost Regulator Builder Disable bit⁽¹⁾
 1 = On-chip boost regulator builder is disabled; digital output control interface is enabled
 0 = On-chip boost regulator builder is active

bit 1 **UVCMPDIS:** On-Chip VBUS Comparator Disable bit⁽¹⁾
 1 = On-chip charge VBUS comparator is disabled; digital input status interface is enabled
 0 = On-chip charge VBUS comparator is active

bit 0 **UTRDIS:** On-Chip Transceiver Disable bit⁽¹⁾
 1 = On-chip transceiver is disabled; digital transceiver interface is enabled
 0 = On-chip transceiver is active

Note 1: Never change these bits while the USBPWR bit is set (U1PWRC<0> = 1).

PIC24FJ256DA210 FAMILY

[查询PIC24FJ256DA106供应商](#)

18.7.2 USB INTERRUPT REGISTERS

REGISTER 18-14: U1OTGIR: USB OTG INTERRUPT STATUS REGISTER (HOST MODE ONLY)

| | | | | | | | |
|--------|-----|-----|-----|-----|-----|-----|-------|
| U-0 | U-0 | U-0 | U-0 | U-0 | U-0 | U-0 | U-0 |
| — | — | — | — | — | — | — | — |
| bit 15 | | | | | | | bit 8 |

| | | | | | | | |
|-----------|-----------|-----------|-----------|-----------|-----------|-----|-----------|
| R/K-0, HS | R/K-0, HS | R/K-0, HS | R/K-0, HS | R/K-0, HS | R/K-0, HS | U-0 | R/K-0, HS |
| IDIF | T1MSECIF | LSTATEIF | ACTVIF | SESVDIF | SESENDIF | — | VBUSVDIF |
| bit 7 | | | | | | | bit 0 |

| | | | | | | | |
|-------------------|------------------------------------|--|----------------------|----------------------------|--------------------|--|--|
| Legend: | U = Unimplemented bit, read as '0' | | | | | | |
| R = Readable bit | K = Write '1' to clear bit | | | HS = Hardware Settable bit | | | |
| -n = Value at POR | '1' = Bit is set | | '0' = Bit is cleared | | x = Bit is unknown | | |

- bit 15-8 **Unimplemented:** Read as '0'
- bit 7 **IDIF:** ID State Change Indicator bit
 1 = Change in ID state is detected
 0 = No ID state change is detected
- bit 6 **T1MSECIF:** 1 Millisecond Timer bit
 1 = The 1 millisecond timer has expired
 0 = The 1 millisecond timer has not expired
- bit 5 **LSTATEIF:** Line State Stable Indicator bit
 1 = USB line state (as defined by the SE0 and JSTATE bits) has been stable for 1 ms, but different from the last time
 0 = USB line state has not been stable for 1 ms
- bit 4 **ACTVIF:** Bus Activity Indicator bit
 1 = Activity on the D+/D- lines or VBUS is detected
 0 = No activity on the D+/D- lines or VBUS is detected
- bit 3 **SESVDIF:** Session Valid Change Indicator bit
 1 = VBUS has crossed VA_SESS_END (as defined in the USB OTG Specification)⁽¹⁾
 0 = VBUS has not crossed VA_SESS_END
- bit 2 **SESENDIF:** B-Device VBUS Change Indicator bit
 1 = VBUS change on B-device detected; VBUS has crossed VB_SESS_END (as defined in the USB OTG Specification)⁽¹⁾
 0 = VBUS has not crossed VA_SESS_END
- bit 1 **Unimplemented:** Read as '0'
- bit 0 **VBUSVDIF:** A-Device VBUS Change Indicator bit
 1 = VBUS change on A-device is detected; VBUS has crossed VA_VBUS_VLD (as defined in the USB OTG Specification)⁽¹⁾
 0 = No VBUS change on A-device is detected

Note 1: VBUS threshold crossings may be either rising or falling.

| |
|--|
| Note: Individual bits can only be cleared by writing a '1' to the bit position as part of a word write operation on the entire register. Using Boolean instructions or bitwise operations to write to a single bit position will cause all set bits at the moment of the write to become cleared. |
|--|

PIC24FJ256DA210 FAMILY

[查询PIC24FJ256DA106供应商](#)

REGISTER 18-15: U1OTGIE: USB OTG INTERRUPT ENABLE REGISTER (HOST MODE ONLY)

| | | | | | | | |
|--------|-----|-----|-----|-----|-----|-----|-------|
| U-0 | U-0 | U-0 | U-0 | U-0 | U-0 | U-0 | U-0 |
| — | — | — | — | — | — | — | — |
| bit 15 | | | | | | | bit 8 |

| | | | | | | | |
|-------|----------|----------|--------|--------|----------|-----|----------|
| R/W-0 | R/W-0 | R/W-0 | R/W-0 | R/W-0 | R/W-0 | U-0 | R/W-0 |
| IDIE | T1MSECIE | LSTATEIE | ACTVIE | SESVIE | SESENDIE | — | VBUSVDIE |
| bit 7 | | | | | | | bit 0 |

Legend:

R = Readable bit W = Writable bit U = Unimplemented bit, read as '0'
 -n = Value at POR '1' = Bit is set '0' = Bit is cleared x = Bit is unknown

- bit 15-8 **Unimplemented:** Read as '0'
- bit 7 **IDIE:** ID Interrupt Enable bit
 1 = Interrupt is enabled
 0 = Interrupt is disabled
- bit 6 **T1MSECIE:** 1 Millisecond Timer Interrupt Enable bit
 1 = Interrupt is enabled
 0 = Interrupt is disabled
- bit 5 **LSTATEIE:** Line State Stable Interrupt Enable bit
 1 = Interrupt is enabled
 0 = Interrupt is disabled
- bit 4 **ACTVIE:** Bus Activity Interrupt Enable bit
 1 = Interrupt is enabled
 0 = Interrupt is disabled
- bit 3 **SESVIE:** Session Valid Interrupt Enable bit
 1 = Interrupt is enabled
 0 = Interrupt is disabled
- bit 2 **SESENDIE:** B-Device Session End Interrupt Enable bit
 1 = Interrupt is enabled
 0 = Interrupt is disabled
- bit 1 **Unimplemented:** Read as '0'
- bit 0 **VBUSVDIE:** A-Device Vbus Valid Interrupt Enable bit
 1 = Interrupt is enabled
 0 = Interrupt is disabled

PIC24FJ256DA210 FAMILY

[查询PIC24FJ256DA106供应商](#)

REGISTER 18-16: U1IR: USB INTERRUPT STATUS REGISTER (DEVICE MODE ONLY)

| | | | | | | | |
|--------|-----|-----|-----|-----|-----|-----|-------|
| U-0 | U-0 | U-0 | U-0 | U-0 | U-0 | U-0 | U-0 |
| — | — | — | — | — | — | — | — |
| bit 15 | | | | | | | bit 8 |

| | | | | | | | |
|-----------|-----|-----------|-----------|-----------|-----------|--------|-----------|
| R/K-0, HS | U-0 | R/K-0, HS | R/K-0, HS | R/K-0, HS | R/K-0, HS | R-0 | R/K-0, HS |
| STALLIF | — | RESUMEIF | IDLEIF | TRNIF | SOFIF | UERRIF | URSTIF |
| bit 7 | | | | | | | bit 0 |

| | | | |
|-------------------|------------------------------------|----------------------------|--------------------|
| Legend: | U = Unimplemented bit, read as '0' | | |
| R = Readable bit | K = Write '1' to clear bit | HS = Hardware Settable bit | |
| -n = Value at POR | '1' = Bit is set | '0' = Bit is cleared | x = Bit is unknown |

- bit 15-8 **Unimplemented:** Read as '0'
- bit 7 **STALLIF:** STALL Handshake Interrupt bit
 1 = A STALL handshake was sent by the peripheral during the handshake phase of the transaction in Device mode
 0 = A STALL handshake has not been sent
- bit 6 **Unimplemented:** Read as '0'
- bit 5 **RESUMEIF:** Resume Interrupt bit
 1 = A K-state is observed on the D+ or D- pin for 2.5 μ s (differential '1' for low speed, differential '0' for full speed)
 0 = No K-state is observed
- bit 4 **IDLEIF:** Idle Detect Interrupt bit
 1 = Idle condition is detected (constant Idle state of 3 ms or more)
 0 = No Idle condition is detected
- bit 3 **TRNIF:** Token Processing Complete Interrupt bit
 1 = Processing of the current token is complete; read the U1STAT register for endpoint information
 0 = Processing of the current token is not complete; clear the U1STAT register or load the next token from STAT (clearing this bit causes the STAT FIFO to advance)
- bit 2 **SOFIF:** Start-Of-Frame Token Interrupt bit
 1 = A Start-Of-Frame token is received by the peripheral or the Start-Of-Frame threshold is reached by the host
 0 = No Start-Of-Frame token is received or threshold reached
- bit 1 **UERRIF:** USB Error Condition Interrupt bit (read-only)
 1 = An unmasked error condition has occurred; only error states enabled in the U1EIE register can set this bit
 0 = No unmasked error condition has occurred
- bit 0 **URSTIF:** USB Reset Interrupt bit
 1 = Valid USB Reset has occurred for at least 2.5 μ s; Reset state must be cleared before this bit can be reasserted
 0 = No USB Reset has occurred. Individual bits can only be cleared by writing a '1' to the bit position as part of a word write operation on the entire register. Using Boolean instructions or bitwise operations to write to a single bit position will cause all set bits at the moment of the write to become cleared.

Note: Individual bits can only be cleared by writing a '1' to the bit position as part of a word write operation on the entire register. Using Boolean instructions or bitwise operations to write to a single bit position will cause all set bits at the moment of the write to become cleared.

PIC24FJ256DA210 FAMILY

[查询PIC24FJ256DA106供应商](#)

REGISTER 18-17: UTIR: USB INTERRUPT STATUS REGISTER (HOST MODE ONLY)

| | | | | | | | |
|--------|-----|-----|-----|-----|-----|-----|-------|
| U-0 | U-0 | U-0 | U-0 | U-0 | U-0 | U-0 | U-0 |
| — | — | — | — | — | — | — | — |
| bit 15 | | | | | | | bit 8 |

| | | | | | | | |
|-----------|-----------|-----------|-----------|-----------|-----------|--------|-----------|
| R/K-0, HS | R/K-0, HS | R/K-0, HS | R/K-0, HS | R/K-0, HS | R/K-0, HS | R-0 | R/K-0, HS |
| STALLIF | ATTACHIF | RESUMEIF | IDLEIF | TRNIF | SOFIF | UERRIF | DETACHIF |
| bit 7 | | | | | | | bit 0 |

| | | | |
|-------------------|------------------------------------|----------------------------|--------------------|
| Legend: | U = Unimplemented bit, read as '0' | | |
| R = Readable bit | K = Write '1' to clear bit | HS = Hardware Settable bit | |
| -n = Value at POR | '1' = Bit is set | '0' = Bit is cleared | x = Bit is unknown |

- bit 15-8 **Unimplemented:** Read as '0'
- bit 7 **STALLIF:** STALL Handshake Interrupt bit
 1 = A STALL handshake was sent by the peripheral device during the handshake phase of the transaction in Device mode
 0 = A STALL handshake has not been sent
- bit 6 **ATTACHIF:** Peripheral Attach Interrupt bit
 1 = A peripheral attachment has been detected by the module; it is set if the bus state is not SE0 and there has been no bus activity for 2.5 μ s
 0 = No peripheral attachment has been detected
- bit 5 **RESUMEIF:** Resume Interrupt bit
 1 = A K-state is observed on the D+ or D- pin for 2.5 μ s (differential '1' for low speed, differential '0' for full speed)
 0 = No K-state is observed
- bit 4 **IDLEIF:** Idle Detect Interrupt bit
 1 = Idle condition is detected (constant Idle state of 3 ms or more)
 0 = No Idle condition is detected
- bit 3 **TRNIF:** Token Processing Complete Interrupt bit
 1 = Processing of the current token is complete; read the U1STAT register for endpoint information
 0 = Processing of the current token not complete; clear the U1STAT register or load the next token from U1STAT
- bit 2 **SOFIF:** Start-Of-Frame Token Interrupt bit
 1 = A Start-Of-Frame token received by the peripheral or the Start-Of-Frame threshold reached by the host
 0 = No Start-Of-Frame token received or threshold reached
- bit 1 **UERRIF:** USB Error Condition Interrupt bit
 1 = An unmasked error condition has occurred; only error states enabled in the U1EIE register can set this bit
 0 = No unmasked error condition has occurred
- bit 0 **DETACHIF:** Detach Interrupt bit
 1 = A peripheral detachment has been detected by the module; Reset state must be cleared before this bit can be reasserted
 0 = No peripheral detachment is detected. Individual bits can only be cleared by writing a '1' to the bit position as part of a word write operation on the entire register. Using Boolean instructions or bitwise operations to write to a single bit position will cause all set bits at the moment of the write to become cleared.

Note: Individual bits can only be cleared by writing a '1' to the bit position as part of a word write operation on the entire register. Using Boolean instructions or bitwise operations to write to a single bit position will cause all set bits at the moment of the write to become cleared.

PIC24FJ256DA210 FAMILY

查询PIC24FJ256DA106供应商

REGISTER 18-18: U1IE: USB INTERRUPT ENABLE REGISTER (ALL USB MODES)

| | | | | | | | |
|--------|-----|-----|-----|-----|-----|-----|-------|
| U-0 | U-0 | U-0 | U-0 | U-0 | U-0 | U-0 | U-0 |
| — | — | — | — | — | — | — | — |
| bit 15 | | | | | | | bit 8 |

| | | | | | | | |
|---------|-------------------------|----------|--------|-------|-------|--------|----------|
| R/W-0 | R/W-0 | R/W-0 | R/W-0 | R/W-0 | R/W-0 | R/W-0 | R/W-0 |
| STALLIE | ATTACHIE ⁽¹⁾ | RESUMEIE | IDLEIE | TRNIE | SOFIE | UERRIE | URSTIE |
| | | | | | | | DETACHIE |
| bit 7 | | | | | | | bit 0 |

Legend:

R = Readable bit W = Writable bit U = Unimplemented bit, read as '0'
 -n = Value at POR '1' = Bit is set '0' = Bit is cleared x = Bit is unknown

- bit 15-8 **Unimplemented:** Read as '0'
- bit 7 **STALLIE:** STALL Handshake Interrupt Enable bit
 1 = Interrupt is enabled
 0 = Interrupt is disabled
- bit 6 **ATTACHIE:** Peripheral Attach Interrupt bit (Host mode only)⁽¹⁾
 1 = Interrupt is enabled
 0 = Interrupt is disabled
- bit 5 **RESUMEIE:** Resume Interrupt bit
 1 = Interrupt is enabled
 0 = Interrupt is disabled
- bit 4 **IDLEIE:** Idle Detect Interrupt bit
 1 = Interrupt is enabled
 0 = Interrupt is disabled
- bit 3 **TRNIE:** Token Processing Complete Interrupt bit
 1 = Interrupt is enabled
 0 = Interrupt is disabled
- bit 2 **SOFIE:** Start-Of-Frame Token Interrupt bit
 1 = Interrupt is enabled
 0 = Interrupt is disabled
- bit 1 **UERRIE:** USB Error Condition Interrupt bit
 1 = Interrupt is enabled
 0 = Interrupt is disabled
- bit 0 **URSTIE or DETACHIE:** USB Reset Interrupt (Device mode) or USB Detach Interrupt (Host mode) Enable bit
 1 = Interrupt is enabled
 0 = Interrupt is disabled

Note 1: Unimplemented in Device mode, read as '0'.

PIC24FJ256DA210 FAMILY

[查询PIC24FJ256DA106供应商](#)

REGISTER 18-19: U1EIR: USB ERROR INTERRUPT STATUS REGISTER

| | | | | | | | |
|--------|-----|-----|-----|-----|-----|-----|-------|
| U-0 | U-0 | U-0 | U-0 | U-0 | U-0 | U-0 | U-0 |
| — | — | — | — | — | — | — | — |
| bit 15 | | | | | | | bit 8 |

| | | | | | | | |
|-----------|-----|-----------|-----------|-----------|-----------|-----------|-----------|
| R/K-0, HS | U-0 | R/K-0, HS | R/K-0, HS | R/K-0, HS | R/K-0, HS | R/K-0, HS | R/K-0, HS |
| BTSEF | — | DMAEF | BTOEF | DFN8EF | CRC16EF | CRC5EF | PIDEF |
| | | | | | | EOFEF | |
| bit 7 | | | | | | | bit 0 |

| | |
|-------------------|------------------------------------|
| Legend: | U = Unimplemented bit, read as '0' |
| R = Readable bit | K = Write '1' to clear bit |
| -n = Value at POR | '1' = Bit is set |
| | HS = Hardware Settable bit |
| | '0' = Bit is cleared |
| | x = Bit is unknown |

bit 15-8 **Unimplemented:** Read as '0'

bit 7 **BTSEF:** Bit Stuff Error Flag bit
 1 = Bit stuff error has been detected
 0 = No bit stuff error has been detected

bit 6 **Unimplemented:** Read as '0'

bit 5 **DMAEF:** DMA Error Flag bit
 1 = A USB DMA error condition is detected; the data size indicated by the BD byte count field is less than the number of received bytes, the received data is truncated
 0 = No DMA error

bit 4 **BTOEF:** Bus Turnaround Time-out Error Flag bit
 1 = Bus turnaround time-out has occurred
 0 = No bus turnaround time-out

bit 3 **DFN8EF:** Data Field Size Error Flag bit
 1 = Data field was not an integral number of bytes
 0 = Data field was an integral number of bytes

bit 2 **CRC16EF:** CRC16 Failure Flag bit
 1 = CRC16 failed
 0 = CRC16 passed

bit 1 For Device mode:
CRC5EF: CRC5 Host Error Flag bit
 1 = Token packet is rejected due to CRC5 error
 0 = Token packet is accepted (no CRC5 error)

For Host mode:
EOFEF: End-Of-Frame Error Flag bit
 1 = End-Of-Frame error has occurred
 0 = End-Of-Frame interrupt is disabled

bit 0 **PIDEF:** PID Check Failure Flag bit
 1 = PID check failed
 0 = PID check passed

Note: Individual bits can only be cleared by writing a '1' to the bit position as part of a word write operation on the entire register. Using Boolean instructions or bitwise operations to write to a single bit position will cause all set bits at the moment of the write to become cleared.

PIC24FJ256DA210 FAMILY

查询PIC24FJ256DA106供应商

REGISTER 18-20: U1EIE: USB ERROR INTERRUPT ENABLE REGISTER

| | | | | | | | |
|--------|-----|-----|-----|-----|-----|-----|-------|
| U-0 | U-0 | U-0 | U-0 | U-0 | U-0 | U-0 | U-0 |
| — | — | — | — | — | — | — | — |
| bit 15 | | | | | | | bit 8 |

| | | | | | | | |
|-------|-----|-------|-------|--------|---------|--------|-------|
| R/W-0 | U-0 | R/W-0 | R/W-0 | R/W-0 | R/W-0 | R/W-0 | R/W-0 |
| BTSEE | — | DMAEE | BTOEE | DFN8EE | CRC16EE | CRC5EE | PIDEE |
| | | | | | | EOFEE | |
| bit 7 | | | | | | | bit 0 |

Legend:

R = Readable bit

W = Writable bit

U = Unimplemented bit, read as '0'

-n = Value at POR

'1' = Bit is set

'0' = Bit is cleared

x = Bit is unknown

- bit 15-8 **Unimplemented:** Read as '0'
- bit 7 **BTSEE:** Bit Stuff Error Interrupt Enable bit
 1 = Interrupt is enabled
 0 = Interrupt is disabled
- bit 6 **Unimplemented:** Read as '0'
- bit 5 **DMAEE:** DMA Error Interrupt Enable bit
 1 = Interrupt is enabled
 0 = Interrupt is disabled
- bit 4 **BTOEE:** Bus Turnaround Time-out Error Interrupt Enable bit
 1 = Interrupt is enabled
 0 = Interrupt is disabled
- bit 3 **DFN8EE:** Data Field Size Error Interrupt Enable bit
 1 = Interrupt is enabled
 0 = Interrupt is disabled
- bit 2 **CRC16EE:** CRC16 Failure Interrupt Enable bit
 1 = Interrupt is enabled
 0 = Interrupt is disabled
- bit 1 For Device mode:
CRC5EE: CRC5 Host Error Interrupt Enable bit
 1 = Interrupt is enabled
 0 = Interrupt is disabled
For Host mode:
EOFEE: End-of-Frame Error interrupt Enable bit
 1 = Interrupt is enabled
 0 = Interrupt is disabled
- bit 0 **PIDEE:** PID Check Failure Interrupt Enable bit
 1 = Interrupt is enabled
 0 = Interrupt is disabled

PIC24FJ256DA210 FAMILY

[查询PIC24FJ256DA106供应商](#)

18.7.3 USB ENDPOINT MANAGEMENT REGISTERS

REGISTER 18-21: U1EPn: USB ENDPOINT n CONTROL REGISTERS (n = 0 TO 15)

| | | | | | | | |
|--------|-----|-----|-----|-----|-----|-----|-------|
| U-0 | U-0 | U-0 | U-0 | U-0 | U-0 | U-0 | U-0 |
| — | — | — | — | — | — | — | — |
| bit 15 | | | | | | | bit 8 |

| | | | | | | | |
|---------------------|-------------------------|-----|----------|--------|--------|---------|-------|
| R/W-0 | R/W-0 | U-0 | R/W-0 | R/W-0 | R/W-0 | R/W-0 | R/W-0 |
| LSPD ⁽¹⁾ | RETRYDIS ⁽¹⁾ | — | EPCONDIS | EPRXEN | EPTXEN | EPSTALL | EPHSK |
| bit 7 | | | | | | | bit 0 |

Legend:

R = Readable bit W = Writable bit U = Unimplemented bit, read as '0'
 -n = Value at POR '1' = Bit is set '0' = Bit is cleared x = Bit is unknown

- bit 15-8 **Unimplemented:** Read as '0'
- bit 7 **LSPD:** Low-Speed Direct Connection Enable bit (U1EP0 only)⁽¹⁾
 1 = Direct connection to a low-speed device is enabled
 0 = Direct connection to a low-speed device is disabled
- bit 6 **RETRYDIS:** Retry Disable bit (U1EP0 only)⁽¹⁾
 1 = Retry NAK transactions is disabled
 0 = Retry NAK transactions is enabled; retry is done in hardware
- bit 5 **Unimplemented:** Read as '0'
- bit 4 **EPCONDIS:** Bidirectional Endpoint Control bit
 If EPTXEN and EPRXEN = 1:
 1 = Disable Endpoint n from control transfers; only TX and RX transfers are allowed
 0 = Enable Endpoint n for control (SETUP) transfers; TX and RX transfers are also allowed
 For all other combinations of EPTXEN and EPRXEN:
 This bit is ignored.
- bit 3 **EPRXEN:** Endpoint Receive Enable bit
 1 = Endpoint n receive is enabled
 0 = Endpoint n receive is disabled
- bit 2 **EPTXEN:** Endpoint Transmit Enable bit
 1 = Endpoint n transmit is enabled
 0 = Endpoint n transmit is disabled
- bit 1 **EPSTALL:** Endpoint Stall Status bit
 1 = Endpoint n was stalled
 0 = Endpoint n was not stalled
- bit 0 **EPHSK:** Endpoint Handshake Enable bit
 1 = Endpoint handshake is enabled
 0 = Endpoint handshake is disabled (typically used for isochronous endpoints)

Note 1: These bits are available only for U1EP0 and only in Host mode. For all other U1EPn registers, these bits are always unimplemented and read as '0'.

PIC24FJ256DA210 FAMILY

[查询PIC24FJ256DA106供应商](#)

18.7.4 USB VBUS POWER CONTROL REGISTER

REGISTER 18-22: U1PWMCON: USB VBus PWM GENERATOR CONTROL REGISTER

| | | | | | | | |
|--------|-----|-----|-----|-----|-----|--------|-------|
| R/W-0 | U-0 | U-0 | U-0 | U-0 | U-0 | R/W-0 | R/W-0 |
| PWMEN | — | — | — | — | — | PWMPOL | CNTEN |
| bit 15 | | | | | | | bit 8 |

| | | | | | | | |
|-------|-----|-----|-----|-----|-----|-----|-------|
| U-0 | U-0 | U-0 | U-0 | U-0 | U-0 | U-0 | U-0 |
| — | — | — | — | — | — | — | — |
| bit 7 | | | | | | | bit 0 |

Legend:

R = Readable bit

W = Writable bit

U = Unimplemented bit, read as '0'

-n = Value at POR

'1' = Bit is set

'0' = Bit is cleared

x = Bit is unknown

bit 15

PWMEN: PWM Enable bit

1 = PWM generator is enabled

0 = PWM generator is disabled; output is held in the Reset state specified by PWMPOL

bit 14-10

Unimplemented: Read as '0'

bit 9

PWMPOL: PWM Polarity bit

1 = PWM output is active-low and resets high

0 = PWM output is active-high and resets low

bit 8

CNTEN: PWM Counter Enable bit

1 = Counter is enabled

0 = Counter is disabled

bit 7-0

Unimplemented: Read as '0'

PIC24FJ256DA210 FAMILY

[查询PIC24FJ256DA106供应商](#)

19.0 ENHANCED PARALLEL MASTER PORT (EPMP)

Note: This data sheet summarizes the features of this group of PIC24F devices. It is not intended to be a comprehensive reference source. For more information, refer to the “PIC24F Family Reference Manual”, **Section 42. “Enhanced Parallel Master Port (EPMP)”** (DS39730). The information in this data sheet supersedes the information in the FRM.

The Enhanced Parallel Master Port (EPMP) module is present in PIC24FJXXXDAX10 devices and not in PIC24FJXXXDAX06 devices. The EPMP provides a parallel 4-bit (Master mode only), 8-bit (Master and Slave modes) or 16-bit (Master mode only) data bus interface to communicate with off-chip modules, such as memories, FIFOs, LCD controllers and other micro-controllers. This module can serve as either the master or the slave on the communication bus. For EPMP Master modes, all external addresses are mapped into the internal Extended Data Space (EDS). This is done by allocating a region of the EDS for each chip select, and then assigning each chip select to a particular external resource, such as a memory or external controller. This region should not be assigned to another device resource, such as RAM or SFRs. To perform a write or read on an external resource, the CPU should simply perform a write or read within the address range assigned for EPMP.

Note: The EPMP module is not present in 64-pin devices (PIC24FJXXXDAX06).

The EPMP has an alternative master feature. The graphics controller module can control the EPMP directly in Alternate Master mode to access an external graphics buffer.

TABLE 19-1: ALTERNATE EPMP PINS

| Pin | $\overline{\text{ALTPMP}} = 0$ | $\overline{\text{ALTPMP}} = 1$ |
|------|--------------------------------|--------------------------------|
| RA14 | PMCS2 | PMA22 |
| RC4 | PMA22 | PMCS2 |
| RF12 | PMA5 | PMA18 |
| RG6 | PMA18 | PMA5 |
| RG7 | PMA20 | PMA4 |
| RA3 | PMA4 | PMA20 |
| RG8 | PMA21 | PMA3 |
| RA4 | PMA3 | PMA21 |

Key features of the EPMP module are:

- Extended Data Space (EDS) interface allows Direct Access from the CPU
- Up to 23 Programmable Address Lines
- Up to 2 Chip Select Lines
- Up to 2 Acknowledgement Lines (one per chip select)
- 4-bit, 8-bit or 16-bit wide Data Bus
- Programmable Strobe Options (per chip select)
 - Individual Read and Write Strobes or;
 - Read/ $\overline{\text{Write}}$ Strobe with Enable Strobe
- Programmable Address/Data Multiplexing
- Programmable Address Wait States
- Programmable Data Wait States (per chip select)
- Programmable Polarity on Control Signals (per chip select)
- Legacy Parallel Slave Port Support
- Enhanced Parallel Slave Support
 - Address Support
 - 4-Byte Deep Auto-Incrementing Buffer
- Alternate Master feature

19.1 $\overline{\text{ALTPMP}}$ Setting

Many of the lower order EPMP address pins are shared with ADC inputs. This is an untenable situation for users that need both the ADC channels and the EPMP bus. If the user does not need to use all the address bits, then by clearing the $\overline{\text{ALTPMP}}$ (CW3<12>) Configuration bit, the lower order address bits can be mapped to higher address pins, which frees the ADC channels.

PIC24FJ256DA210 FAMILY

[查询PIC24FJ256DA106供应商](#)

TABLE 19-2: PARALLEL MASTER PORT PIN DESCRIPTION

| Pin Name | Type | Description |
|--------------------------------------|------|--|
| PMA<22:16> | O | Address bus bits<22-16> |
| PMA<15>, PMCS2 | O | Address bus bit<15> |
| | O | Chip Select 2 (alternate location) |
| | I/O | Data bus bit<15> when port size is 16 bits and address is multiplexed |
| PMA<14>, PMCS1 | O | Address bus bit<14> |
| | O | Chip Select 1 (alternate location) |
| | I/O | Data bus bit 14 when port size is 16-bit and address is multiplexed |
| PMA<13:8> | O | Address bus bit< 13-8> |
| | I/O | Data bus bits<13-8> when port size is 16 bits and address is multiplexed |
| PMA<7:3> | O | Address bus bit< 7-3> |
| PMA<2>, PMALU | O | Address bus bit<2> |
| | O | Address latch upper strobe for multiplexed address |
| PMA<1>, PMALH | I/O | Address bus bit<1> |
| | O | Address latch high strobe for multiplexed address |
| PMA<0>, PMALL | I/O | Address bus bit<0> |
| | O | Address latch low strobe for multiplexed address |
| PMD<15:8> | I/O | Data bus bits<15-8> when address is not multiplexed |
| PMD<7:4> | I/O | Data bus bits<7-4> |
| | O | Address bus bits<7-4> when port size is 4 bits and address is multiplexed with 1 address phase |
| PMD<3:0> | I/O | Data bus bits<3-0> |
| PMCS1 | I/O | Chip Select 1 |
| PMCS2 | O | Chip Select 2 |
| PMWR, PMENB | I/O | Write strobe or Enable signal depending on Strobe mode |
| PMRD, PMRD/ $\overline{\text{PMWR}}$ | I/O | Read strobe or Read/Write signal depending on Strobe mode |
| PMBE1 | O | Byte indicator |
| PMBE0 | O | Nibble or byte indicator |
| PMACK1 | I | Acknowledgment 1 |
| PMACK2 | I | Acknowledgment 2 |

PIC24FJ256DA210 FAMILY

[查询PIC24FJ256DA106供应商](#)

REGISTER 19-1: PMCON1: EPMP CONTROL REGISTER 1

| | | | | | | | |
|--------|-----|-------|---------|---------|-----|-------|-------|
| R/W-0 | U-0 | R/W-0 | R/W-0 | R/W-0 | U-0 | R/W-0 | R/W-0 |
| PMPEN | — | PSIDL | ADRMUX1 | ADRMUX0 | — | MODE1 | MODE0 |
| bit 15 | | | | | | | bit 8 |

| | | | | | | | |
|-------|-------|-------|--------|-----|---------|-------|-------|
| R/W-0 | R/W-0 | R/W-0 | R/W-0 | U-0 | R/W-0 | R/W-0 | R/W-0 |
| CSF1 | CSF0 | ALP | ALMODE | — | BUSKEEP | IRQM1 | IRQM0 |
| bit 7 | | | | | | | bit 0 |

Legend:

R = Readable bit W = Writable bit U = Unimplemented bit, read as '0'
 -n = Value at POR '1' = Bit is set '0' = Bit is cleared x = Bit is unknown

- bit 15 **PMPEN:** Parallel Master Port Enable bit
 1 = EPMP is enabled
 0 = EPMP is disabled
- bit 14 **Unimplemented:** Read as '0'
- bit 13 **PSIDL:** Stop in Idle Mode bit
 1 = Discontinue module operation when device enters Idle mode
 0 = Continue module operation in Idle mode
- bit 12-11 **ADRMUX<1:0>:** Address/Data Multiplexing Selection bits
 11 = Lower address bits are multiplexed with data bits using 3 address phases
 10 = Lower address bits are multiplexed with data bits using 2 address phases
 01 = Lower address bits are multiplexed with data bits using 1 address phase
 00 = Address and data appear on separate pins
- bit 10 **Unimplemented:** Read as '0'
- bit 9-8 **MODE<1:0>:** Parallel Port Mode Select bits
 11 = Master mode
 10 = Enhanced PSP; pins used are PMRD, PMWR, PMCS, PMD<7:0> and PMA<1:0>
 01 = Buffered PSP; pins used are PMRD, PMWR, PMCS and PMD<7:0>
 00 = Legacy Parallel Slave Port; PMRD, PMWR, PMCS and PMD<7:0> pins are used
- bit 7-6 **CSF<1:0>:** Chip Select Function bits
 11 = Reserved
 10 = PMA<15> used for Chip Select 2, PMA<14> used for Chip Select 1
 01 = PMA<15> used for Chip Select 2, PMCS1 used for Chip Select 1
 00 = PMCS2 used for Chip Select 2, PMCS1 used for Chip Select 1
- bit 5 **ALP:** Address Latch Polarity bit
 1 = Active-high (PMALL, PMALH and PMALU)
 0 = Active-low (PMALL, PMALH and PMALU)
- bit 4 **ALMODE:** Address Latch Strobe Mode bit
 1 = Enable "smart" address strobes (each address phase is only present if the current access would cause a different address in the latch than the previous address)
 0 = Disable "smart" address strobes
- bit 3 **Unimplemented:** Read as '0'
- bit 2 **BUSKEEP:** Bus Keeper bit
 1 = Data bus keeps its last value when not actively being driven
 0 = Data bus is in high-impedance state when not actively being driven
- bit 1-0 **IRQM<1:0>:** Interrupt Request Mode bits
 11 = Interrupt generated when Read Buffer 3 is read or Write Buffer 3 is written (Buffered PSP mode), or on a read or write operation when PMA<1:0> = 11 (Addressable PSP mode only)
 10 = Reserved
 01 = Interrupt generated at the end of a read/write cycle
 00 = No interrupt is generated

PIC24FJ256DA210 FAMILY

查询PIC24FJ256DA106供应商

REGISTER 19-2: PMCON2: EPMP CONTROL REGISTER 2

| | | | | | | | |
|----------|-----|-----------|-----------|----------|----------|---------|---------|
| R-0, HSC | U-0 | R/C-0, HS | R/C-0, HS | R-0, HSC | R-1, HSC | R/W-0 | R/W-0 |
| BUSY | — | ERROR | TIMEOUT | AMREQ | CURMST | MSTSEL1 | MSTSEL0 |
| bit 15 | | | | | | bit 8 | |

| | | | | | | | |
|---------|---------|---------|---------|---------|---------|---------|---------|
| R/W-0 | R/W-0 | R/W-0 | R/W-0 | R/W-0 | R/W-0 | R/W-0 | R/W-0 |
| RADDR23 | RADDR22 | RADDR21 | RADDR20 | RADDR19 | RADDR18 | RADDR17 | RADDR16 |
| bit 7 | | | | | | bit 0 | |

| | | |
|-------------------|----------------------------|--|
| Legend: | HS = Hardware Settable bit | HSC = Hardware Settable/Clearable bit |
| R = Readable bit | W = Writable bit | U = Unimplemented bit, read as '0' C = Clearable bit |
| -n = Value at POR | '1' = Bit is set | '0' = Bit is cleared x = Bit is unknown |

- bit 15 **BUSY:** Busy bit (Master mode only)
 - 1 = Port is busy
 - 0 = Port is not busy
- bit 14 **Unimplemented:** Read as '0'
- bit 13 **ERROR:** Error bit
 - 1 = Transaction error (illegal transaction was requested)
 - 0 = Transaction completed successfully
- bit 12 **TIMEOUT:** Time-Out bit
 - 1 = Transaction timed out
 - 0 = Transaction completed successfully
- bit 11 **AMREQ:** Alternate Master Request bit
 - 1 = The Alternate Master is requesting use of EPMP
 - 0 = The Alternate Master is not requesting use of EPMP
- bit 10 **CURMST:** Current Master bit
 - 1 = EPMP access is granted to CPU
 - 0 = EPMP access is granted to alternate master
- bit 9-8 **MSTSEL<1:0>:** Parallel Port Master Select bits
 - 11 = Alternate master I/Os direct access (EPMP Bypass mode)
 - 10 = Reserved
 - 01 = Alternate master
 - 00 = CPU
- bit 7-0 **RADDR<23:16>:** Parallel Master Port Reserved Address Space bits⁽¹⁾

Note 1: If RADDR<23:16> = 00000000, then the last EDS address for Chip Select 2 will be 0xFFFFF.

PIC24FJ256DA210 FAMILY

[查询PIC24FJ256DA106供应商](#)

REGISTER 19-3: PMCON3: EPMP CONTROL REGISTER 3

| | | | | | | | |
|--------|--------|---------|---------|-----|---------|---------|--------|
| R/W-0 | R/W-0 | R/W-0 | R/W-0 | U-0 | R/W-0 | R/W-0 | R/W-0 |
| PTWREN | PTRDEN | PTBE1EN | PTBE0EN | — | AWAITM1 | AWAITM0 | AWAITE |
| bit 15 | | | | | | bit 8 | |

| | | | | | | | |
|-------|--------|--------|--------|--------|--------|--------|--------|
| U-0 | R/W-0 | R/W-0 | R/W-0 | R/W-0 | R/W-0 | R/W-0 | R/W-0 |
| — | PTEN22 | PTEN21 | PTEN20 | PTEN19 | PTEN18 | PTEN17 | PTEN16 |
| bit 7 | | | | | | bit 0 | |

Legend:

| | | |
|-------------------|------------------|--|
| R = Readable bit | W = Writable bit | U = Unimplemented bit, read as '0' |
| -n = Value at POR | '1' = Bit is set | '0' = Bit is cleared x = Bit is unknown |

- bit 15 **PTWREN:** Write/Enable Strobe Port Enable bit
1 = PMWR/PMENB port is enabled
0 = PMWR/PMENB port is disabled
- bit 14 **PTRDEN:** Read/Write Strobe Port Enable bit
1 = PMRD/PMWR port is enabled
0 = PMRD/PMWR port is disabled
- bit 13 **PTBE1EN:** High Nibble/Byte Enable Port Enable bit
1 = PMBE1 port is enabled
0 = PMBE1 port is disabled
- bit 12 **PTBE0EN:** Low Nibble/Byte Enable Port Enable bit
1 = PMBE0 port is enabled
0 = PMBE0 port is disabled
- bit 11 **Unimplemented:** Read as '0'
- bit 10-9 **AWAITM<1:0>:** Address Latch Strobe Wait States bits
11 = Wait of 3½ TcY
10 = Wait of 2½ TcY
01 = Wait of 1½ TcY
00 = Wait of ½ TcY
- bit bit 8 **AWAITE:** Address Hold After Address Latch Strobe Wait States bits
1 = Wait of 1¼ TcY
0 = Wait of ¼ TcY
- bit 7 **Unimplemented:** Read as '0'
- bit 6-0 **PTEN<22:16>:** EPMP Address Port Enable bits
1 = PMA<22:16> function as EPMP address lines
0 = PMA<22:16> function as port I/Os

PIC24FJ256DA210 FAMILY

[查询PIC24FJ256DA106供应商](#)

REGISTER 19-4: PMCON4: EPMP CONTROL REGISTER 4

| | | | | | | | |
|--------|--------|--------|--------|--------|--------|-------|-------|
| R/W-0 | R/W-0 | R/W-0 | R/W-0 | R/W-0 | R/W-0 | R/W-0 | R/W-0 |
| PTEN15 | PTEN14 | PTEN13 | PTEN12 | PTEN11 | PTEN10 | PTEN9 | PTEN8 |
| bit 15 | | | | | | | bit 8 |

| | | | | | | | |
|-------|-------|-------|-------|-------|-------|-------|-------|
| R/W-0 | R/W-0 | R/W-0 | R/W-0 | R/W-0 | R/W-0 | R/W-0 | R/W-0 |
| PTEN7 | PTEN6 | PTEN5 | PTEN4 | PTEN3 | PTEN2 | PTEN1 | PTEN0 |
| bit 7 | | | | | | | bit 0 |

Legend:

R = Readable bit

W = Writable bit

U = Unimplemented bit, read as '0'

-n = Value at POR

'1' = Bit is set

'0' = Bit is cleared

x = Bit is unknown

- bit 15 **PTEN15:** PMA15 Port Enable bit
1 = PMA15 functions as either Address Line 15 or Chip Select 2
0 = PMA15 functions as port I/O
- bit 14 **PTEN14:** PMA14 Port Enable bit
1 = PMA14 functions as either Address Line 14 or Chip Select 1
0 = PMA14 functions as port I/O
- bit 13-3 **PTEN<13:3>:** EPMP Address Port Enable bits
1 = PMA<13:3> function as EPMP address lines
0 = PMA<13:3> function as port I/Os
- bit 2-0 **PTEN<2:0>:** PMALU/PMALH/PMALL Strobe Enable bits
1 = PMA<2:0> function as either address lines or address latch strobes
0 = PMA<2:0> function as port I/Os

PIC24FJ256DA210 FAMILY

[查询PIC24FJ256DA106供应商](#)

REGISTER 19-5: PMCSxCF: CHIP SELECT x CONFIGURATION REGISTER

| | | | | | | | |
|--------|-------|--------|-------|-----|-------|-------|-------|
| R/W-0 | R/W-0 | R/W-0 | R/W-0 | U-0 | R/W-0 | R/W-0 | R/W-0 |
| CSDIS | CSP | CSPTEN | BEP | — | WRSP | RDSP | SM |
| bit 15 | | | | | | bit 8 | |

| | | | | | | | |
|-------|-------|-------|-----|-----|-----|-------|-----|
| R/W-0 | R/W-0 | R/W-0 | U-0 | U-0 | U-0 | U-0 | U-0 |
| ACKP | PTSZ1 | PTSZ0 | — | — | — | — | — |
| bit 7 | | | | | | bit 0 | |

Legend:

R = Readable bit W = Writable bit U = Unimplemented bit, read as '0'
 -n = Value at POR '1' = Bit is set '0' = Bit is cleared x = Bit is unknown

- bit 15 **CSDIS:** Chip Select x Disable bit
 1 = Disable the Chip Select x functionality
 0 = Enable the Chip Select x functionality
- bit 14 **CSP:** Chip Select x Polarity bit
 1 = Active-high (PMCSx)
 0 = Active-low (PMCSx)
- bit 13 **CSPTEN:** PMCSx Port Enable bit
 1 = PMCSx port is enabled
 0 = PMCSx port is disabled
- bit 12 **BEP:** Chip Select x Nibble/Byte Enable Polarity bit
 1 = Nibble/Byte enable active-high (PMBE0, PMBE1)
 0 = Nibble/Byte enable active-low (PMBE0, PMBE1)
- bit 11 **Unimplemented:** Read as '0'
- bit 10 **WRSP:** Chip Select x Write Strobe Polarity bit
 For Slave modes and Master mode when SM = 0:
 1 = Write strobe active-high (PMWR)
 0 = Write strobe active-low (PMWR)
 For Master mode when SM = 1:
 1 = Enable strobe active-high (PMENB)
 0 = Enable strobe active-low (PMENB)
- bit 9 **RDSP:** Chip Select x Read Strobe Polarity bit
 For Slave modes and Master mode when SM = 0:
 1 = Read strobe active-high (PMRD)
 0 = Read strobe active-low (PMRD)
 For Master mode when SM = 1:
 1 = Read/write strobe active-high (PMRD/PMWR)
 0 = Read/Write strobe active-low (PMRD/PMWR)
- bit 8 **SM:** Chip Select x Strobe Mode bit
 1 = Read/Write and enable strobes (PMRD/PMWR and PMENB)
 0 = Read and write strobes (PMRD and PMWR)
- bit 7 **ACKP:** Chip Select x Acknowledge Polarity bit
 1 = ACK active-high (PMACK1)
 0 = ACK active-low (PMACK1)
- bit 6-5 **PTSZ<1:0>:** Chip Select x Port Size bits
 11 = Reserved
 10 = 16-bit port size (PMD<15:0>)
 01 = 4-bit port size (PMD<3:0>)
 00 = 8-bit port size (PMD<7:0>)
- bit 4-0 **Unimplemented:** Read as '0'

PIC24FJ256DA210 FAMILY

[查询PIC24FJ256DA106供应商](#)

REGISTER 19-6: PMCSxBS: CHIP SELECT x BASE ADDRESS REGISTER

| | | | | | | | |
|--------------------|--------------------|--------------------|--------------------|--------------------|--------------------|--------------------|--------------------|
| R/W ⁽¹⁾ | R/W ⁽¹⁾ | R/W ⁽¹⁾ | R/W ⁽¹⁾ | R/W ⁽¹⁾ | R/W ⁽¹⁾ | R/W ⁽¹⁾ | R/W ⁽¹⁾ |
| BASE23 | BASE22 | BASE21 | BASE20 | BASE19 | BASE18 | BASE17 | BASE16 |
| bit 15 | | | | | | | bit 8 |

| | | | | | | | |
|--------------------|-----|-----|-----|--------------------|-----|-----|-------|
| R/W ⁽¹⁾ | U-0 | U-0 | U-0 | R/W ⁽¹⁾ | U-0 | U-0 | U-0 |
| BASE15 | — | — | — | BASE11 | — | — | — |
| bit 7 | | | | | | | bit 0 |

Legend:

R = Readable bit W = Writable bit U = Unimplemented bit, read as '0'
 -n = Value at POR '1' = Bit is set '0' = Bit is cleared x = Bit is unknown

- bit 15-7 **BASE<23:15>**: Chip Select x Base Address bits⁽²⁾
- bit 6-4 **Unimplemented**: Read as '0'
- bit 3 **BASE<11>**: Chip Select x Base Address bits⁽²⁾
- bit 2-0 **Unimplemented**: Read as '0'

- Note 1:** Value at POR is 0x0200 for PMCS1BS and 0x0600 for PMCS2BS.
- 2:** If the whole PMCS2BS register is written together as 0x0000, then the last EDS address for the Chip Select 1 will be 0xFFFFF. In this case, the Chip Select 2 should not be used. PMCS1BS has no such feature.

PIC24FJ256DA210 FAMILY

[查询PIC24FJ256DA106供应商](#)

REGISTER 19-7: PMCSxMD: CHIP SELECT x MODE REGISTER

| | | | | | | | |
|--------|-------|---------|---------|---------|-----|-------|-----|
| R/W-0 | R/W-0 | R/W-0 | R/W-0 | R/W-0 | U-0 | U-0 | U-0 |
| ACKM1 | ACKM0 | AMWAIT2 | AMWAIT1 | AMWAIT0 | — | — | — |
| bit 15 | | | | | | bit 8 | |

| | | | | | | | |
|---------|---------|---------|---------|---------|---------|---------|---------|
| R/W-0 | R/W-0 | R/W-0 | R/W-0 | R/W-0 | R/W-0 | R/W-0 | R/W-0 |
| DWAITB1 | DWAITB0 | DWAITM3 | DWAITM2 | DWAITM1 | DWAITM0 | DWAITE1 | DWAITE0 |
| bit 7 | | | | | | bit 0 | |

Legend:

| | | |
|-------------------|------------------|------------------------------------|
| R = Readable bit | W = Writable bit | U = Unimplemented bit, read as '0' |
| -n = Value at POR | '1' = Bit is set | '0' = Bit is cleared |
| | | x = Bit is unknown |

bit 15-14 **ACKM<1:0>**: Chip Select x Acknowledge Mode bits

11 = Reserved
 10 = PMACKx is used to determine when a read/write operation is complete
 01 = PMACKx is used to determine when a read/write operation is complete with time-out
 If DWAITM<3:0> = 0000, the maximum time-out is 255 Tcy, else it is DWAITM<3:0> cycles.
 00 = PMACKx is not used

bit 13-11 **AMWAIT<2:0>**: Chip Select x Alternate Master Wait States bits

111 = Wait of 10 alternate master cycles
 ...
 001 = Wait of 4 alternate master cycles
 000 = Wait of 3 alternate master cycles

bit 10-8 **Unimplemented**: Read as '0'

bit 7-6 **DWAITB<1:0>**: Chip Select x Data Setup Before Read/Write Strobe Wait States bits

11 = Wait of 3¼ Tcy
 10 = Wait of 2¼ Tcy
 01 = Wait of 1¼ Tcy
 00 = Wait of ¼ Tcy

bit 5-2 **DWAITM<3:0>**: Chip Select x Data Read/Write Strobe Wait States bits

For Write operations:
 1111 = Wait of 15½ Tcy
 ...
 0001 = Wait of 1½ Tcy
 0000 = Wait of ½ Tcy
For Read operations:
 1111 = Wait of 15¾ Tcy
 ...
 0001 = Wait of 1¾ Tcy
 0000 = Wait of ¾ Tcy

bit 1-0 **DWAITE<1:0>**: Chip Select x Data Hold After Read/Write Strobe Wait States bits

For Write operations:
 11 = Wait of 3¼ Tcy
 10 = Wait of 2¼ Tcy
 01 = Wait of 1¼ Tcy
 00 = Wait of ¼ Tcy
For Read operations:
 11 = Wait of 3 Tcy
 10 = Wait of 2 Tcy
 01 = Wait of 1 Tcy
 00 = Wait of 0 Tcy

PIC24FJ256DA210 FAMILY

[查询PIC24FJ256DA106供应商](#)

REGISTER 19-8: PMSTAT: EPMP STATUS REGISTER (SLAVE MODE ONLY)

| | | | | | | | |
|----------|----------|-----|-----|----------|----------|----------|----------|
| R-0, HSC | R/W-0 HS | U-0 | U-0 | R-0, HSC | R-0, HSC | R-0, HSC | R-0, HSC |
| IBF | IBOV | — | — | IB3F | IB2F | IB1F | IB0F |
| bit 15 | | | | | | | bit 8 |

| | | | | | | | |
|----------|----------|-----|-----|----------|----------|----------|----------|
| R-1, HSC | R/W-0 HS | U-0 | U-0 | R-1, HSC | R-1, HSC | R-1, HSC | R-1, HSC |
| OBE | OBUF | — | — | OB3E | OB2E | OB1E | OB0E |
| bit 7 | | | | | | | bit 0 |

| | | |
|-------------------|----------------------------|--|
| Legend: | HS = Hardware Settable bit | HSC = Hardware Settable/Clearable bit |
| R = Readable bit | W = Writable bit | U = Unimplemented bit, read as '0' |
| -n = Value at POR | '1' = Bit is set | '0' = Bit is cleared x = Bit is unknown |

- bit 15 **IBF:** Input Buffer Full Status bit
 1 = All writable input buffer registers are full
 0 = Some or all of the writable input buffer registers are empty
- bit 14 **IBOV:** Input Buffer Overflow Status bit
 1 = A write attempt to a full input register occurred (must be cleared in software)
 0 = No overflow occurred
- bit 13-12 **Unimplemented:** Read as '0'
- bit 11-8 **IBxF:** Input Buffer x Status Full bit⁽¹⁾
 1 = Input buffer contains unread data (reading buffer will clear this bit)
 0 = Input buffer does not contain unread data
- bit 7 **OBE:** Output Buffer Empty Status bit
 1 = All readable output buffer registers are empty
 0 = Some or all of the readable output buffer registers are full
- bit 6 **OBUF:** Output Buffer Underflow Status bit
 1 = A read occurred from an empty output register (must be cleared in software)
 0 = No underflow occurred
- bit 5-4 **Unimplemented:** Read as '0'
- bit 3-0 **OBxE:** Output Buffer x Status Empty bit
 1 = Output buffer is empty (writing data to the buffer will clear this bit)
 0 = Output buffer contains untransmitted data

Note 1: Even though an individual bit represents the byte in the buffer, the bits corresponding to the Word (byte 0 and 1, or byte 2 and 3) gets cleared even on byte reading.

PIC24FJ256DA210 FAMILY

[查询PIC24FJ256DA106供应商](#)

REGISTER 19-9: PADCFG1: PAD CONFIGURATION CONTROL REGISTER

| | | | | | | | |
|--------|-----|-----|-----|-----|-----|-----|-------|
| U-0 | U-0 | U-0 | U-0 | U-0 | U-0 | U-0 | U-0 |
| — | — | — | — | — | — | — | — |
| bit 15 | | | | | | | bit 8 |

| | | | | | | | |
|-------|-----|-----|-----|-----|-----|-------------------------|-----------------------|
| U-0 | U-0 | U-0 | U-0 | U-0 | U-0 | R/W-0 | R/W-0 |
| — | — | — | — | — | — | RTSECSEL ⁽¹⁾ | PMPTTL ⁽²⁾ |
| bit 7 | | | | | | | bit 0 |

Legend:

R = Readable bit W = Writable bit U = Unimplemented bit, read as '0'
-n = Value at POR '1' = Bit is set '0' = Bit is cleared x = Bit is unknown

bit 15-2 **Unimplemented:** Read as '0'

bit 1 **RTSECSEL:** RTCC Seconds Clock Output Select bit⁽¹⁾

1 = RTCC seconds clock is selected for the RTCC pin

0 = RTCC alarm pulse is selected for the RTCC pin

bit 0 **PMPTTL:** EPMP Module TTL Input Buffer Select bit⁽²⁾

1 = EPMP module inputs (PMDx, PMCS1) use TTL input buffers

0 = EPMP module inputs use Schmitt Trigger input buffers

Note 1: To enable the actual RTCC output, the RTCOE (RCFGCAL<10>) bit must also be set.

Note 2: Unimplemented in 64-pin devices (PIC24FJXXXDAX06); maintain as '0'.

PIC24FJ256DA210 FAMILY

[查询PIC24FJ256DA106供应商](#)

NOTES:

PIC24FJ256DA210 FAMILY

[查询PIC24FJ256DA106供应商](#)

20.0 REAL-TIME CLOCK AND CALENDAR (RTCC)

Note: This data sheet summarizes the features of this group of PIC24F devices. It is not intended to be a comprehensive reference source. For more information, refer to the “PIC24F Family Reference Manual”, Section 29. “Real-Time Clock and Calendar (RTCC)” (DS39696). The information in this data sheet supersedes the information in the FRM.

The Real-Time Clock and Calendar (RTCC) provides a function that can be calibrated.

Key features of the RTCC module are:

- Operates in Sleep mode
- Provides hours, minutes and seconds using 24-hour format

- Visibility of half of one second period
- Provides calendar – weekday, date, month and year
- Alarm configurable for half a second, one second, 10 seconds, one minute, 10 minutes, one hour, one day, one week, one month or one year
- Alarm repeat with decremting counter
- Alarm with indefinite repeat chime
- Year, 2000 to 2099, leap year correction
- BCD format for smaller software overhead
- Optimized for long-term battery operation
- User calibration of the 32.768 kHz clock crystal/32K INTRC frequency with periodic auto-adjust
 - Calibration to within ± 2.64 seconds error per month
 - Calibrates up to 260 ppm of crystal error

FIGURE 20-1: RTCC BLOCK DIAGRAM

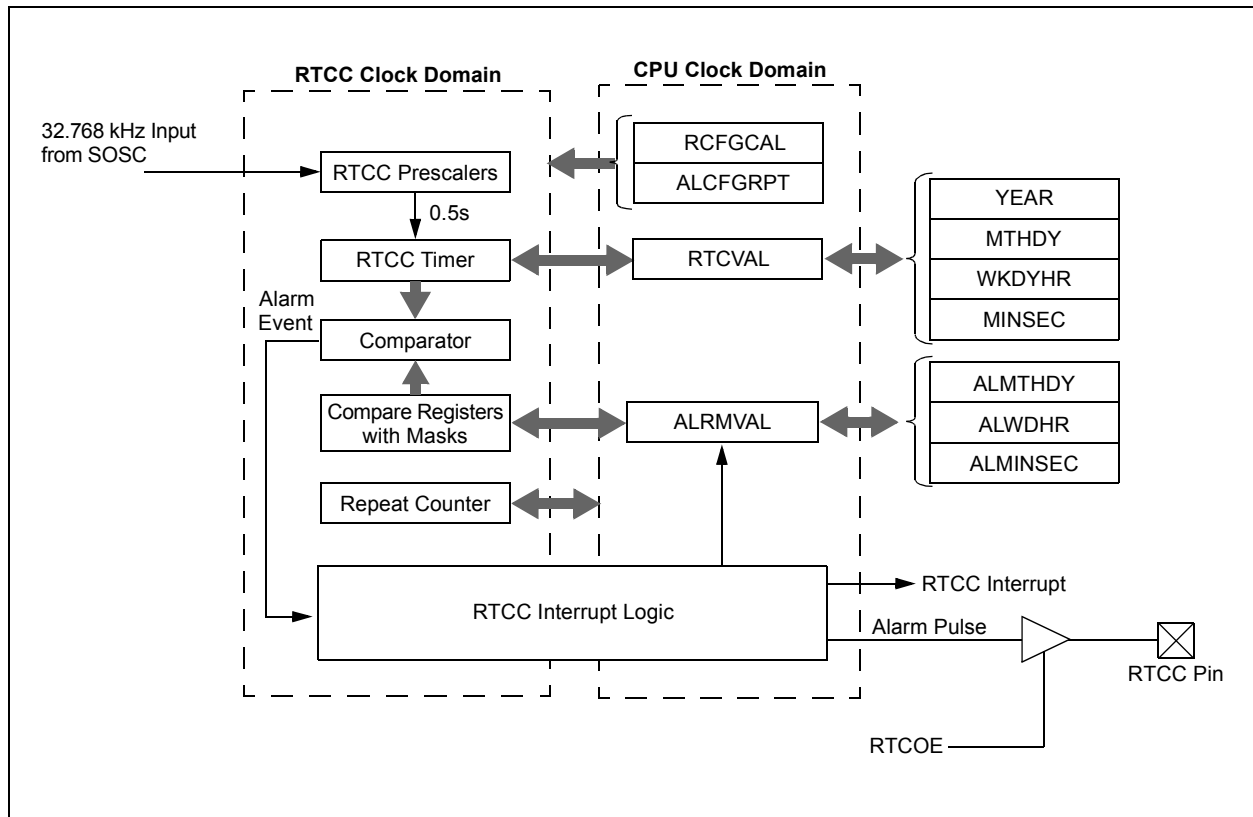

PIC24FJ256DA210 FAMILY

[查询PIC24FJ256DA106供应商](#)

20.1 RTCC Module Registers

The RTCC module registers are organized into three categories:

- RTCC Control Registers
- RTCC Value Registers
- Alarm Value Registers

20.1.1 REGISTER MAPPING

To limit the register interface, the RTCC Timer and Alarm Time registers are accessed through the corresponding register pointers. The RTCC Value register window (RTCVALH and RTCVALL) uses the RTCPTR bits (RCFGCAL<9:8>) to select the desired Timer register pair (see Table 20-1).

By writing the RTCVALH byte, the RTCC Pointer value, RTCPTR<1:0> bits, decrement by one until they reach '00'. Once they reach '00', the MINUTES and SECONDS value will be accessible through RTCVALH and RTCVALL until the pointer value is manually changed.

TABLE 20-1: RTCVAL REGISTER MAPPING

| RTCPTR <1:0> | RTCC Value Register Window | |
|-----------------|----------------------------|-------------|
| | RTCVAL<15:8> | RTCVAL<7:0> |
| 00 | MINUTES | SECONDS |
| 01 | WEEKDAY | HOURS |
| 10 | MONTH | DAY |
| 11 | — | YEAR |

The Alarm Value register window (ALRMVALH and ALRMVALL) uses the ALRMPTR bits (ALCFGRPT<9:8>) to select the desired Alarm register pair (see Table 20-2).

By writing the ALRMVALH byte, the Alarm Pointer value bits, ALRMPTR<1:0>, decrement by one until they reach '00'. Once they reach '00', the ALRMMIN and ALRMSEC value will be accessible through ALRMVALH and ALRMVALL until the pointer value is manually changed.

EXAMPLE 20-1: SETTING THE RTCWREN BIT

```
asm volatile("disi #5");
asm volatile("mov #0x55, w7");
asm volatile("mov w7, _NVMKEY");
asm volatile("mov #0xAA, w8");
asm volatile("mov w8, _NVMKEY");
asm volatile("bset _RCFGCAL, #13"); //set the RTCWREN bit
```

TABLE 20-2: ALRMVAL REGISTER MAPPING

| ALRMPTR <1:0> | Alarm Value Register Window | |
|------------------|-----------------------------|--------------|
| | ALRMVAL<15:8> | ALRMVAL<7:0> |
| 00 | ALRMMIN | ALRMSEC |
| 01 | ALRMWD | ALRMHR |
| 10 | ALRMMNTH | ALRMDAY |
| 11 | — | — |

Considering that the 16-bit core does not distinguish between 8-bit and 16-bit read operations, the user must be aware that when reading either the ALRMVALH or ALRMVALL bytes, they will decrement the ALRMPTR<1:0> value. The same applies to the RTCVALH or RTCVALL bytes with the RTCPTR<1:0> being decremented.

Note: This only applies to read operations and not write operations.

20.1.2 WRITE LOCK

In order to perform a write to any of the RTCC Timer registers, the RTCWREN (RCFGCAL<13>) bit must be set (refer to Example 20-1).

Note: To avoid accidental writes to the timer, it is recommended that the RTCWREN bit (RCFGCAL<13>) is kept clear at any other time. For the RTCWREN bit to be set, there is only 1 instruction cycle time window allowed between the unlock sequence and the setting of RTCWREN; therefore, it is recommended that code follow the procedure in Example 20-1.

For applications written in C, the unlock sequence should be implemented using in-line assembly.

PIC24FJ256DA210 FAMILY

[查询PIC24FJ256DA106供应商](#)

20.1.3 RTCC CONTROL REGISTERS

REGISTER 20-1: RCFGAL: RTCC CALIBRATION AND CONFIGURATION REGISTER⁽¹⁾

| | | | | | | | |
|----------------------|-----|---------|----------|------------------------|-------|------------|------------|
| R/W-0 | U-0 | R/W-0 | R-0, HSC | R-0, HSC | R/W-0 | R/W-0, HSC | R/W-0, HSC |
| RTCEN ⁽²⁾ | — | RTCWREN | RTCSYNC | HALFSEC ⁽³⁾ | RTCOE | RTCPTR1 | RTCPTR0 |
| bit 15 | | | | | | bit 8 | |

| | | | | | | | |
|-------|-------|-------|-------|-------|-------|-------|-------|
| R/W-0 | R/W-0 | R/W-0 | R/W-0 | R/W-0 | R/W-0 | R/W-0 | R/W-0 |
| CAL7 | CAL6 | CAL5 | CAL4 | CAL3 | CAL2 | CAL1 | CAL0 |
| bit 7 | | | | | | bit 0 | |

| | | | |
|-------------------|---------------------------------------|------------------------------------|--------------------|
| Legend: | HSC = Hardware Settable/Clearable bit | | |
| R = Readable bit | W = Writable bit | U = Unimplemented bit, read as '0' | |
| -n = Value at POR | '1' = Bit is set | '0' = Bit is cleared | x = Bit is unknown |

- bit 15 **RTCEN:** RTCC Enable bit⁽²⁾
 1 = RTCC module is enabled
 0 = RTCC module is disabled
- bit 14 **Unimplemented:** Read as '0'
- bit 13 **RTCWREN:** RTCC Value Registers Write Enable bit
 1 = RTCVALH and RTCVALL registers can be written to by the user
 0 = RTCVALH and RTCVALL registers are locked out from being written to by the user
- bit 12 **RTCSYNC:** RTCC Value Registers Read Synchronization bit
 1 = RTCVALH, RTCVALL and ALCFGRPT registers can change while reading due to a rollover ripple resulting in an invalid data read. If the register is read twice and results in the same data, the data can be assumed to be valid.
 0 = RTCVALH, RTCVALL or ALCFGRPT registers can be read without concern over a rollover ripple
- bit 11 **HALFSEC:** Half-Second Status bit⁽³⁾
 1 = Second half period of a second
 0 = First half period of a second
- bit 10 **RTCOE:** RTCC Output Enable bit
 1 = RTCC output is enabled
 0 = RTCC output is disabled
- bit 9-8 **RTCPTR<1:0>:** RTCC Value Register Window Pointer bits
 Points to the corresponding RTCC Value registers when reading the RTCVALH and RTCVALL registers. The RTCPTR<1:0> value decrements on every read or write of RTCVALH until it reaches '00'.
 RTCVAL<15:8>:
 11 = Reserved
 10 = MONTH
 01 = WEEKDAY
 00 = MINUTES
 RTCVAL<7:0>:
 11 = YEAR
 10 = DAY
 01 = HOURS
 00 = SECONDS

- Note 1:** The RCFGAL register is only affected by a POR.
2: A write to the RTCEN bit is only allowed when RTCWREN = 1.
3: This bit is read-only. It is cleared to '0' on a write to the lower half of the MINSEC register.

PIC24FJ256DA210 FAMILY

[查询PIC24FJ256DA106供应商](#)

REGISTER 20-1: RCFGAL: RTCC CALIBRATION AND CONFIGURATION REGISTER⁽¹⁾

bit 7-0 **CAL<7:0>**: RTC Drift Calibration bits
01111111 = Maximum positive adjustment; adds 508 RTC clock pulses every one minute
.
.
11111111 = Minimum negative adjustment; subtracts 4 RTC clock pulses every one minute
00000001 = Minimum positive adjustment; adds 4 RTC clock pulses every one minute
00000000 = No adjustment
.
.
10000000 = Maximum negative adjustment; subtracts 512 RTC clock pulses every one minute

- Note 1:** The RCFGAL register is only affected by a POR.
Note 2: A write to the RTCEN bit is only allowed when RTCWREN = 1.
Note 3: This bit is read-only. It is cleared to '0' on a write to the lower half of the MINSEC register.

REGISTER 20-2: PADCFG1: PAD CONFIGURATION CONTROL REGISTER

| | | | | | | | |
|--------|-----|-----|-----|-----|-----|-----|-------|
| U-0 | U-0 | U-0 | U-0 | U-0 | U-0 | U-0 | U-0 |
| — | — | — | — | — | — | — | — |
| bit 15 | | | | | | | bit 8 |

| | | | | | | | |
|-------|-----|-----|-----|-----|-----|-------------------------|--------|
| U-0 | U-0 | U-0 | U-0 | U-0 | U-0 | R/W-0 | R/W-0 |
| — | — | — | — | — | — | RTSECSEL ⁽¹⁾ | PMPTTL |
| bit 7 | | | | | | | bit 0 |

Legend:

R = Readable bit W = Writable bit U = Unimplemented bit, read as '0'
-n = Value at POR '1' = Bit is set '0' = Bit is cleared x = Bit is unknown

bit 15-2 **Unimplemented:** Read as '0'
bit 1 **RTSECSEL:** RTCC Seconds Clock Output Select bit⁽¹⁾
1 = RTCC seconds clock is selected for the RTCC pin
0 = RTCC alarm pulse is selected for the RTCC pin
bit 0 **PMPTTL:** EPMP Module TTL Input Buffer Select bit
1 = EPMP module inputs (PMDx, PMCS1) use TTL input buffers
0 = EPMP module inputs use Schmitt Trigger input buffers

- Note 1:** To enable the actual RTCC output, the RTCOE (RCFGAL<10>) bit must also be set.

PIC24FJ256DA210 FAMILY

[查询PIC24FJ256DA106供应商](#)

REGISTER 20-3: ALCFGRPT: ALARM CONFIGURATION REGISTER

| | | | | | | | |
|--------|-------|--------|--------|--------|--------|------------|------------|
| R/W-0 | R/W-0 | R/W-0 | R/W-0 | R/W-0 | R/W-0 | R/W-0, HSC | R/W-0, HSC |
| ALRMEN | CHIME | AMASK3 | AMASK2 | AMASK1 | AMASK0 | ALRMPTR1 | ALRMPTR0 |
| bit 15 | | | | | | bit 8 | |

| | | | | | | | |
|------------|------------|------------|------------|------------|------------|------------|------------|
| R/W-0, HSC | R/W-0, HSC | R/W-0, HSC | R/W-0, HSC | R/W-0, HSC | R/W-0, HSC | R/W-0, HSC | R/W-0, HSC |
| ARPT7 | ARPT6 | ARPT5 | ARPT4 | ARPT3 | ARPT2 | ARPT1 | ARPT0 |
| bit 7 | | | | | | bit 0 | |

| | | | |
|-------------------|---------------------------------------|------------------------------------|--------------------|
| Legend: | HSC = Hardware Settable/Clearable bit | | |
| R = Readable bit | W = Writable bit | U = Unimplemented bit, read as '0' | |
| -n = Value at POR | '1' = Bit is set | '0' = Bit is cleared | x = Bit is unknown |

- bit 15 **ALRMEN:** Alarm Enable bit
 1 = Alarm is enabled (cleared automatically after an alarm event whenever ARPT<7:0> = 00h and CHIME = 0)
 0 = Alarm is disabled
- bit 14 **CHIME:** Chime Enable bit
 1 = Chime is enabled; ARPT<7:0> bits are allowed to roll over from 00h to FFh
 0 = Chime is disabled; ARPT<7:0> bits stop once they reach 00h
- bit 13-10 **AMASK<3:0>:** Alarm Mask Configuration bits
 11xx = Reserved – do not use
 101x = Reserved – do not use
 1001 = Once a year (except when configured for February 29th, once every 4 years)
 1000 = Once a month
 0111 = Once a week
 0110 = Once a day
 0101 = Every hour
 0100 = Every 10 minutes
 0011 = Every minute
 0010 = Every 10 seconds
 0001 = Every second
 0000 = Every half second
- bit 9-8 **ALRMPTR<1:0>:** Alarm Value Register Window Pointer bits
 Points to the corresponding Alarm Value registers when reading the ALRMVALH and ALRMVALL registers. The ALRMPTR<1:0> value decrements on every read or write of ALRMVALH until it reaches '00'.
ALRMVAL<15:8>:
 11 = Unimplemented
 10 = ALRMMNTH
 01 = ALRMWD
 00 = ALRMMIN
ALRMVAL<7:0>:
 11 = Unimplemented
 10 = ALRMDAY
 01 = ALRMHR
 00 = ALRMSEC
- bit 7-0 **ARPT<7:0>:** Alarm Repeat Counter Value bits
 11111111 = Alarm will repeat 255 more times
 ...
 00000000 = Alarm will not repeat
 The counter decrements on any alarm event. The counter is prevented from rolling over from 00h to FFh unless CHIME = 1.

PIC24FJ256DA210 FAMILY

[查询PIC24FJ256DA106供应商](#)

20.1.4 RTCVAL REGISTER MAPPINGS

REGISTER 20-4: YEAR: YEAR VALUE REGISTER⁽¹⁾

| | | | | | | | |
|--------|-----|-----|-----|-----|-----|-----|-------|
| U-0 | U-0 | U-0 | U-0 | U-0 | U-0 | U-0 | U-0 |
| — | — | — | — | — | — | — | — |
| bit 15 | | | | | | | bit 8 |

| | | | | | | | |
|------------|------------|------------|------------|------------|------------|------------|------------|
| R/W-x, HSC | R/W-x, HSC | R/W-x, HSC | R/W-x, HSC | R/W-x, HSC | R/W-x, HSC | R/W-x, HSC | R/W-x, HSC |
| YRTEN3 | YRTEN2 | YRTEN1 | YRTEN0 | YRONE3 | YRONE2 | YRONE1 | YRONE0 |
| bit 7 | | | | | | | bit 0 |

| | | | |
|-------------------|---------------------------------------|------------------------------------|--------------------|
| Legend: | HSC = Hardware Settable/Clearable bit | | |
| R = Readable bit | W = Writable bit | U = Unimplemented bit, read as '0' | |
| -n = Value at POR | '1' = Bit is set | '0' = Bit is cleared | x = Bit is unknown |

- bit 15-8 **Unimplemented:** Read as '0'
- bit 7-4 **YRTEN<3:0>:** Binary Coded Decimal Value of Year's Tens Digit bits
Contains a value from 0 to 9.
- bit 3-0 **YRONE<3:0>:** Binary Coded Decimal Value of Year's Ones Digit bits
Contains a value from 0 to 9.

Note 1: A write to the YEAR register is only allowed when RTCWREN = 1.

REGISTER 20-5: MTHDY: MONTH AND DAY VALUE REGISTER⁽¹⁾

| | | | | | | | |
|--------|-----|-----|------------|------------|------------|------------|------------|
| U-0 | U-0 | U-0 | R/W-x, HSC | R/W-x, HSC | R/W-x, HSC | R/W-x, HSC | R/W-x, HSC |
| — | — | — | MHTTEN0 | MTHONE3 | MTHONE2 | MTHONE1 | MTHONE0 |
| bit 15 | | | | | | | bit 8 |

| | | | | | | | |
|-------|-----|------------|------------|------------|------------|------------|------------|
| U-0 | U-0 | R/W-x, HSC | R/W-x, HSC | R/W-x, HSC | R/W-x, HSC | R/W-x, HSC | R/W-x, HSC |
| — | — | DAYTEN1 | DAYTEN0 | DAYONE3 | DAYONE2 | DAYONE1 | DAYONE0 |
| bit 7 | | | | | | | bit 0 |

| | | | |
|-------------------|---------------------------------------|------------------------------------|--------------------|
| Legend: | HSC = Hardware Settable/Clearable bit | | |
| R = Readable bit | W = Writable bit | U = Unimplemented bit, read as '0' | |
| -n = Value at POR | '1' = Bit is set | '0' = Bit is cleared | x = Bit is unknown |

- bit 15-13 **Unimplemented:** Read as '0'
- bit 12 **MHTTEN0:** Binary Coded Decimal Value of Month's Tens Digit bit
Contains a value of 0 or 1.
- bit 11-8 **MTHONE<3:0>:** Binary Coded Decimal Value of Month's Ones Digit bits
Contains a value from 0 to 9.
- bit 7-6 **Unimplemented:** Read as '0'
- bit 5-4 **DAYTEN<1:0>:** Binary Coded Decimal Value of Day's Tens Digit bits
Contains a value from 0 to 3.
- bit 3-0 **DAYONE<3:0>:** Binary Coded Decimal Value of Day's Ones Digit bits
Contains a value from 0 to 9.

Note 1: A write to this register is only allowed when RTCWREN = 1.

PIC24FJ256DA210 FAMILY

[查询PIC24FJ256DA106供应商](#)

REGISTER 20-6: WKDYHR: WEEKDAY AND HOURS VALUE REGISTER⁽¹⁾

| | | | | | | | |
|--------|-----|-----|-----|-----|------------|------------|------------|
| U-0 | U-0 | U-0 | U-0 | U-0 | R/W-x, HSC | R/W-x, HSC | R/W-x, HSC |
| — | — | — | — | — | WDAY2 | WDAY1 | WDAY0 |
| bit 15 | | | | | | bit 8 | |

| | | | | | | | |
|-------|-----|------------|------------|------------|------------|------------|------------|
| U-0 | U-0 | R/W-x, HSC | R/W-x, HSC | R/W-x, HSC | R/W-x, HSC | R/W-x, HSC | R/W-x, HSC |
| — | — | HRTEN1 | HRTEN0 | HRONE3 | HRONE2 | HRONE1 | HRONE0 |
| bit 7 | | | | | | bit 0 | |

| | | | |
|-------------------|---------------------------------------|------------------------------------|--------------------|
| Legend: | HSC = Hardware Settable/Clearable bit | | |
| R = Readable bit | W = Writable bit | U = Unimplemented bit, read as '0' | |
| -n = Value at POR | '1' = Bit is set | '0' = Bit is cleared | x = Bit is unknown |

- bit 15-11 **Unimplemented:** Read as '0'
- bit 10-8 **WDAY<2:0>:** Binary Coded Decimal Value of Weekday Digit bits
Contains a value from 0 to 6.
- bit 7-6 **Unimplemented:** Read as '0'
- bit 5-4 **HRTEN<1:0>:** Binary Coded Decimal Value of Hour's Tens Digit bits
Contains a value from 0 to 2.
- bit 3-0 **HRONE<3:0>:** Binary Coded Decimal Value of Hour's Ones Digit bits
Contains a value from 0 to 9.

Note 1: A write to this register is only allowed when RTCWREN = 1.

REGISTER 20-7: MINSEC: MINUTES AND SECONDS VALUE REGISTER

| | | | | | | | |
|--------|------------|------------|------------|------------|------------|------------|------------|
| U-0 | R/W-x, HSC | R/W-x, HSC | R/W-x, HSC | R/W-x, HSC | R/W-x, HSC | R/W-x, HSC | R/W-x, HSC |
| — | MINTEN2 | MINTEN1 | MINTEN0 | MINONE3 | MINONE2 | MINONE1 | MINONE0 |
| bit 15 | | | | | | bit 8 | |

| | | | | | | | |
|-------|------------|------------|------------|------------|------------|------------|------------|
| U-0 | R/W-x, HSC | R/W-x, HSC | R/W-x, HSC | R/W-x, HSC | R/W-x, HSC | R/W-x, HSC | R/W-x, HSC |
| — | SECTEN2 | SECTEN1 | SECTEN0 | SECONE3 | SECONE2 | SECONE1 | SECONE0 |
| bit 7 | | | | | | bit 0 | |

| | | | |
|-------------------|---------------------------------------|------------------------------------|--------------------|
| Legend: | HSC = Hardware Settable/Clearable bit | | |
| R = Readable bit | W = Writable bit | U = Unimplemented bit, read as '0' | |
| -n = Value at POR | '1' = Bit is set | '0' = Bit is cleared | x = Bit is unknown |

- bit 15 **Unimplemented:** Read as '0'
- bit 14-12 **MINTEN<2:0>:** Binary Coded Decimal Value of Minute's Tens Digit bits
Contains a value from 0 to 5.
- bit 11-8 **MINONE<3:0>:** Binary Coded Decimal Value of Minute's Ones Digit bits
Contains a value from 0 to 9.
- bit 7 **Unimplemented:** Read as '0'
- bit 6-4 **SECTEN<2:0>:** Binary Coded Decimal Value of Second's Tens Digit bits
Contains a value from 0 to 5.
- bit 3-0 **SECONE<3:0>:** Binary Coded Decimal Value of Second's Ones Digit bits
Contains a value from 0 to 9.

PIC24FJ256DA210 FAMILY

[查询PIC24FJ256DA106供应商](#)

20.1.5 ALRMVAL REGISTER MAPPINGS

REGISTER 20-8: ALMTHDY: ALARM MONTH AND DAY VALUE REGISTER⁽¹⁾

| | | | | | | | |
|--------|-----|-----|--------|---------|---------|---------|---------|
| U-0 | U-0 | U-0 | R/W-x | R/W-x | R/W-x | R/W-x | R/W-x |
| — | — | — | MHTEN0 | MTHONE3 | MTHONE2 | MTHONE1 | MTHONE0 |
| bit 15 | | | | | | | bit 8 |

| | | | | | | | |
|-------|-----|---------|---------|---------|---------|---------|---------|
| U-0 | U-0 | R/W-x | R/W-x | R/W-x | R/W-x | R/W-x | R/W-x |
| — | — | DAYTEN1 | DAYTEN0 | DAYONE3 | DAYONE2 | DAYONE1 | DAYONE0 |
| bit 7 | | | | | | | bit 0 |

Legend:

R = Readable bit

W = Writable bit

U = Unimplemented bit, read as '0'

-n = Value at POR

'1' = Bit is set

'0' = Bit is cleared

x = Bit is unknown

- bit 15-13 **Unimplemented:** Read as '0'
- bit 12 **MHTEN0:** Binary Coded Decimal Value of Month's Tens Digit bit
Contains a value of 0 or 1.
- bit 11-8 **MTHONE<3:0>:** Binary Coded Decimal Value of Month's Ones Digit bits
Contains a value from 0 to 9.
- bit 7-6 **Unimplemented:** Read as '0'
- bit 5-4 **DAYTEN<1:0>:** Binary Coded Decimal Value of Day's Tens Digit bits
Contains a value from 0 to 3.
- bit 3-0 **DAYONE<3:0>:** Binary Coded Decimal Value of Day's Ones Digit bits
Contains a value from 0 to 9.

Note 1: A write to this register is only allowed when RTCWREN = 1.

PIC24FJ256DA210 FAMILY

[查询PIC24FJ256DA106供应商](#)

REGISTER 20-9: ALWDHR: ALARM WEEKDAY AND HOURS VALUE REGISTER⁽¹⁾

| | | | | | | | |
|--------|-----|--------|--------|--------|--------|--------|--------|
| U-0 | U-0 | U-0 | U-0 | U-0 | R/W-x | R/W-x | R/W-x |
| — | — | — | — | — | WDAY2 | WDAY1 | WDAY0 |
| bit 15 | | | | | bit 8 | | |
| U-0 | U-0 | R/W-x | R/W-x | R/W-x | R/W-x | R/W-x | R/W-x |
| — | — | HRTEN1 | HRTEN0 | HRONE3 | HRONE2 | HRONE1 | HRONE0 |
| bit 7 | | bit 0 | | | | | |

Legend:

R = Readable bit W = Writable bit U = Unimplemented bit, read as '0'
 -n = Value at POR '1' = Bit is set '0' = Bit is cleared x = Bit is unknown

- bit 15-11 **Unimplemented:** Read as '0'
- bit 10-8 **WDAY<2:0>:** Binary Coded Decimal Value of Weekday Digit bits
Contains a value from 0 to 6.
- bit 7-6 **Unimplemented:** Read as '0'
- bit 5-4 **HRTEN<1:0>:** Binary Coded Decimal Value of Hour's Tens Digit bits
Contains a value from 0 to 2.
- bit 3-0 **HRONE<3:0>:** Binary Coded Decimal Value of Hour's Ones Digit bits
Contains a value from 0 to 9.

Note 1: A write to this register is only allowed when RTCWREN = 1.

REGISTER 20-10: ALMINSEC: ALARM MINUTES AND SECONDS VALUE REGISTER

| | | | | | | | |
|--------|---------|---------|---------|---------|---------|---------|---------|
| U-0 | R/W-x | R/W-x | R/W-x | R/W-x | R/W-x | R/W-x | R/W-x |
| — | MINTEN2 | MINTEN1 | MINTEN0 | MINONE3 | MINONE2 | MINONE1 | MINONE0 |
| bit 15 | | | | | bit 8 | | |
| U-0 | R/W-x | R/W-x | R/W-x | R/W-x | R/W-x | R/W-x | R/W-x |
| — | SECTEN2 | SECTEN1 | SECTEN0 | SECONE3 | SECONE2 | SECONE1 | SECONE0 |
| bit 7 | | bit 0 | | | | | |

Legend:

R = Readable bit W = Writable bit U = Unimplemented bit, read as '0'
 -n = Value at POR '1' = Bit is set '0' = Bit is cleared x = Bit is unknown

- bit 15 **Unimplemented:** Read as '0'
- bit 14-12 **MINTEN<2:0>:** Binary Coded Decimal Value of Minute's Tens Digit bits
Contains a value from 0 to 5.
- bit 11-8 **MINONE<3:0>:** Binary Coded Decimal Value of Minute's Ones Digit bits
Contains a value from 0 to 9.
- bit 7 **Unimplemented:** Read as '0'
- bit 6-4 **SECTEN<2:0>:** Binary Coded Decimal Value of Second's Tens Digit bits
Contains a value from 0 to 5.
- bit 3-0 **SECONE<3:0>:** Binary Coded Decimal Value of Second's Ones Digit bits
Contains a value from 0 to 9.

PIC24FJ256DA210 FAMILY

[查询PIC24FJ256DA106供应商](#)

20.2 Calibration

The real-time crystal input can be calibrated using the periodic auto-adjust feature. When properly calibrated, the RTCC can provide an error of less than 3 seconds per month. This is accomplished by finding the number of error clock pulses for one minute and storing the value into the lower half of the RCFGAL register. The 8-bit signed value loaded into the lower half of RCFGAL is multiplied by four and will either be added or subtracted from the RTCC timer, once every minute. Refer to the following steps for RTCC calibration:

1. Using another timer resource on the device, the user must find the error of the 32.768 kHz crystal.
2. Once the error is known, it must be converted to the number of error clock pulses per minute and loaded into the RCFGAL register.

EQUATION 20-1: RTCC CALIBRATION

$$\text{Error (clocks per minute)} = (\text{Ideal Frequency}^\dagger - \text{Measured Frequency}) \times 60$$
$$^\dagger \text{Ideal Frequency} = 32,768\text{H}$$

3. a) If the oscillator is faster than ideal (negative result from Step 2), the RCFGAL register value needs to be negative. This causes the specified number of clock pulses to be subtracted from the timer counter, once every minute.
b) If the oscillator is slower than ideal (positive result from Step 2), the RCFGAL register value needs to be positive. This causes the specified number of clock pulses to be added to the timer counter, once every minute.
4. Divide the number of error clocks per minute by 4 to get the correct CAL value and load the RCFGAL register with the correct value.
(Each 1-bit increment in CAL adds or subtracts 4 pulses).

Writes to the lower half of the RCFGAL register should only occur when the timer is turned off or immediately after the rising edge of the seconds pulse.

Note: It is up to the user to include in the error value the initial error of the crystal, drift due to temperature and drift due to crystal aging.

20.3 Alarm

- Configurable from half second to one year
- Enabled using the ALRMEN bit (ALCFGRPT<15>, Register 20-3)
- One-time alarm and repeat alarm options available

20.3.1 CONFIGURING THE ALARM

The alarm feature is enabled using the ALRMEN bit. This bit is cleared when an alarm is issued. Writes to ALRMVAL should only take place when ALRMEN = 0.

As shown in Figure 20-2, the interval selection of the alarm is configured through the AMASK bits (ALCFGRPT<13:10>). These bits determine which and how many digits of the alarm must match the clock value for the alarm to occur.

The alarm can also be configured to repeat based on a preconfigured interval. The amount of times this occurs, once the alarm is enabled, is stored in the ARPT bits, ARPT<7:0> (ALCFGRPT<7:0>). When the value of the ARPT bits equals 00h and the CHIME bit (ALCFGRPT<14>) is cleared, the repeat function is disabled and only a single alarm will occur. The alarm can be repeated up to 255 times by loading ARPT<7:0> with FFh.

After each alarm is issued, the value of the ARPT bits is decremented by one. Once the value has reached 00h, the alarm will be issued one last time, after which the ALRMEN bit will be cleared automatically and the alarm will turn off.

Indefinite repetition of the alarm can occur if the CHIME bit = 1. Instead of the alarm being disabled when the value of the ARPT bits reaches 00h, it rolls over to FFh and continues counting indefinitely while CHIME is set.

20.3.2 ALARM INTERRUPT

At every alarm event, an interrupt is generated. In addition, an alarm pulse output is provided that operates at half the frequency of the alarm. This output is completely synchronous to the RTCC clock and can be used as a trigger clock to other peripherals.

Note: Changing any of the registers, other than the RCFGAL and ALCFGRPT registers and the CHIME bit while the alarm is enabled (ALRMEN = 1), can result in a false alarm event leading to a false alarm interrupt. To avoid a false alarm event, the timer and alarm values should only be changed while the alarm is disabled (ALRMEN = 0). It is recommended that the ALCFGRPT register and CHIME bit be changed when RTCSYNC = 0.

PIC24FJ256DA210 FAMILY

[查询PIC24FJ256DA106供应商](#)

FIGURE 20-2: ALARM MASK SETTINGS

| Alarm Mask Setting (AMASK<3:0>) | Day of the Week | Month | Day | Hours | Minutes | Seconds |
|---|---------------------------------------|---|---|---|---------|---|
| 0000 – Every half second 0001 – Every second | <input type="checkbox"/> | <input type="checkbox"/> <input type="checkbox"/> | / <input type="checkbox"/> <input type="checkbox"/> | <input type="checkbox"/> <input type="checkbox"/> : <input type="checkbox"/> <input type="checkbox"/> : <input type="checkbox"/> <input type="checkbox"/> | | |
| 0010 – Every 10 seconds | <input type="checkbox"/> | <input type="checkbox"/> <input type="checkbox"/> | / <input type="checkbox"/> <input type="checkbox"/> | <input type="checkbox"/> <input type="checkbox"/> : <input type="checkbox"/> <input type="checkbox"/> : <input type="checkbox"/> <input type="checkbox"/> | | <input type="checkbox"/> s |
| 0011 – Every minute | <input type="checkbox"/> | <input type="checkbox"/> <input type="checkbox"/> | / <input type="checkbox"/> <input type="checkbox"/> | <input type="checkbox"/> <input type="checkbox"/> : <input type="checkbox"/> <input type="checkbox"/> : <input type="checkbox"/> <input type="checkbox"/> | | <input type="checkbox"/> s <input type="checkbox"/> s |
| 0100 – Every 10 minutes | <input type="checkbox"/> | <input type="checkbox"/> <input type="checkbox"/> | / <input type="checkbox"/> <input type="checkbox"/> | <input type="checkbox"/> <input type="checkbox"/> : <input type="checkbox"/> m : <input type="checkbox"/> <input type="checkbox"/> | | <input type="checkbox"/> s <input type="checkbox"/> s |
| 0101 – Every hour | <input type="checkbox"/> | <input type="checkbox"/> <input type="checkbox"/> | / <input type="checkbox"/> <input type="checkbox"/> | <input type="checkbox"/> <input type="checkbox"/> : <input type="checkbox"/> m <input type="checkbox"/> m : <input type="checkbox"/> <input type="checkbox"/> | | <input type="checkbox"/> s <input type="checkbox"/> s |
| 0110 – Every day | <input type="checkbox"/> | <input type="checkbox"/> <input type="checkbox"/> | / <input type="checkbox"/> <input type="checkbox"/> | <input type="checkbox"/> h <input type="checkbox"/> h : <input type="checkbox"/> m <input type="checkbox"/> m : <input type="checkbox"/> <input type="checkbox"/> | | <input type="checkbox"/> s <input type="checkbox"/> s |
| 0111 – Every week | <input checked="" type="checkbox"/> d | <input type="checkbox"/> <input type="checkbox"/> | / <input type="checkbox"/> <input type="checkbox"/> | <input type="checkbox"/> h <input type="checkbox"/> h : <input type="checkbox"/> m <input type="checkbox"/> m : <input type="checkbox"/> <input type="checkbox"/> | | <input type="checkbox"/> s <input type="checkbox"/> s |
| 1000 – Every month | <input type="checkbox"/> | <input type="checkbox"/> <input type="checkbox"/> | / <input checked="" type="checkbox"/> <input checked="" type="checkbox"/> | <input type="checkbox"/> h <input type="checkbox"/> h : <input type="checkbox"/> m <input type="checkbox"/> m : <input type="checkbox"/> <input type="checkbox"/> | | <input type="checkbox"/> s <input type="checkbox"/> s |
| 1001 – Every year ⁽¹⁾ | <input type="checkbox"/> | <input type="checkbox"/> m <input type="checkbox"/> m | / <input checked="" type="checkbox"/> <input checked="" type="checkbox"/> | <input type="checkbox"/> h <input type="checkbox"/> h : <input type="checkbox"/> m <input type="checkbox"/> m : <input type="checkbox"/> <input type="checkbox"/> | | <input type="checkbox"/> s <input type="checkbox"/> s |

Note 1: Annually, except when configured for February 29.

PIC24FJ256DA210 FAMILY

[查询PIC24FJ256DA106供应商](#)

NOTES:

PIC24FJ256DA210 FAMILY

[查询PIC24FJ256DA106供应商](#)

21.0 32-BIT PROGRAMMABLE CYCLIC REDUNDANCY CHECK (CRC) GENERATOR

Note: This data sheet summarizes the features of this group of PIC24F devices. It is not intended to be a comprehensive reference source. For more information, refer to the “PIC24F Family Reference Manual”, Section 41. “32-Bit Programmable Cyclic Redundancy Check (CRC)” (DS39729). The information in this data sheet supersedes the information in the FRM.

The 32-bit programmable CRC generator provides a hardware implemented method of quickly generating checksums for various networking and security applications. It offers the following features:

- User-programmable CRC polynomial equation, up to 32 bits
- Programmable shift direction (little or big-endian)
- Independent data and polynomial lengths
- Configurable interrupt output
- Data FIFO

Figure 21-1 displays a simplified block diagram of the CRC generator. A simple version of the CRC shift engine is displayed in Figure 21-2.

FIGURE 21-1: CRC BLOCK DIAGRAM

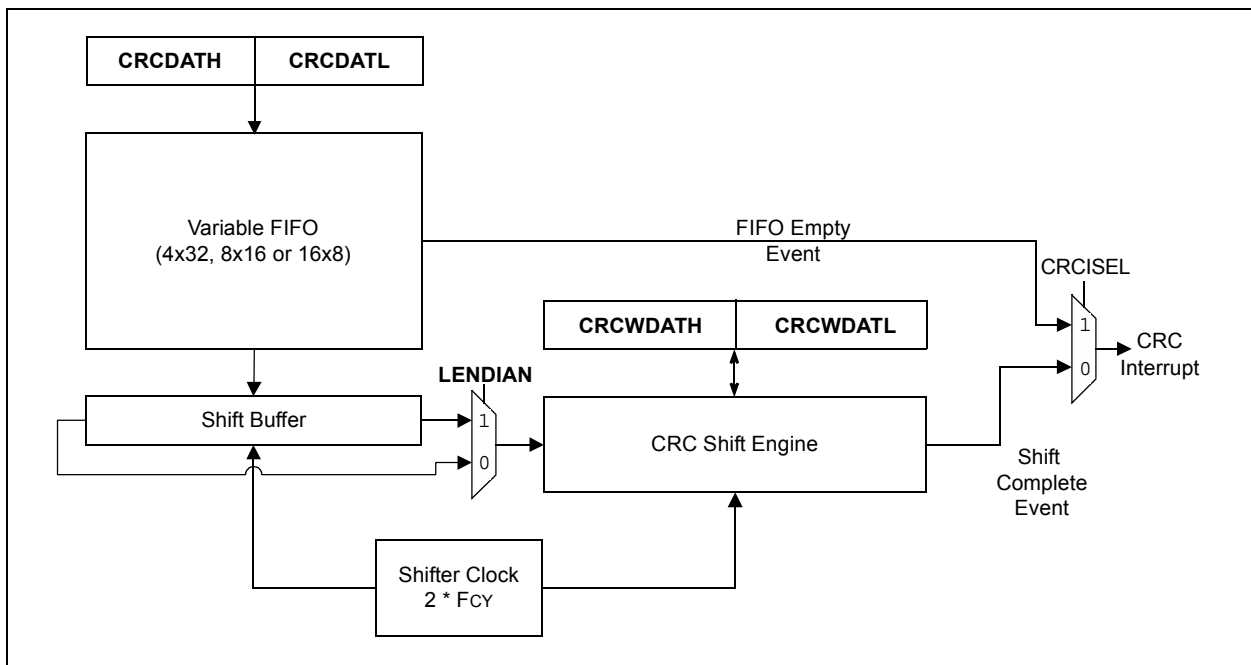
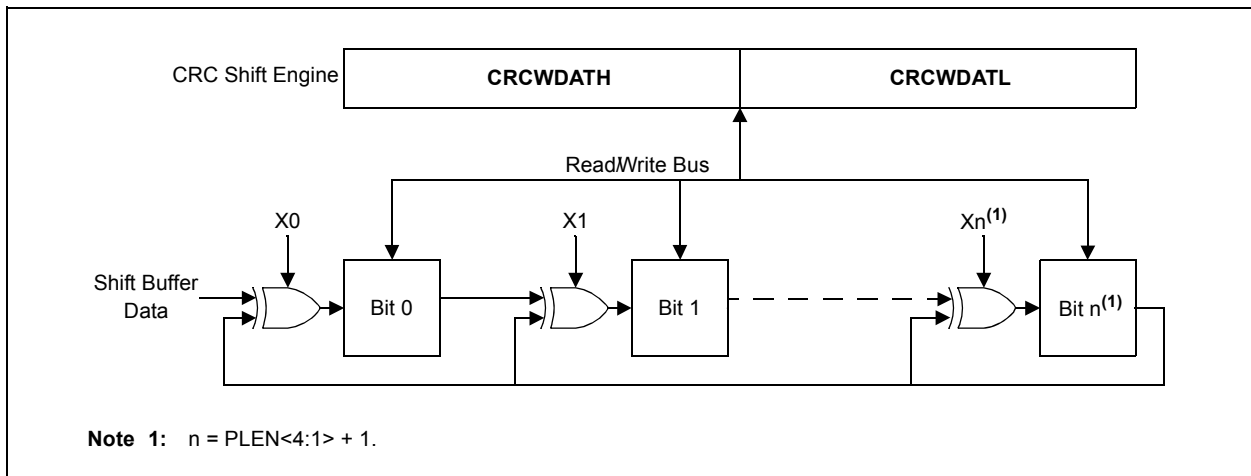

FIGURE 21-2: CRC SHIFT ENGINE DETAIL



PIC24FJ256DA210 FAMILY

[查询PIC24FJ256DA106供应商](#)

21.1 User Interface

21.1.1 POLYNOMIAL INTERFACE

The CRC module can be programmed for CRC polynomials of up to the 32nd order, using up to 32 bits.

Polynomial length, which reflects the highest exponent in the equation, is selected by the PLEN<4:0> bits (CRCCON2<4:0>).

The CRCXORL and CRCXORH registers control which exponent terms are included in the equation. Setting a particular bit includes that exponent term in the equation; functionally, this includes an XOR operation on the corresponding bit in the CRC engine. Clearing the bit disables the XOR.

For example, consider two CRC polynomials, one a 16-bit and the other a 32-bit equation.

EQUATION 21-1: 16-BIT, 32-BIT CRC POLYNOMIALS

$$\begin{aligned}
 &X^{16} + X^{12} + X^5 + 1 \\
 &\text{and} \\
 &X^{32} + X^{26} + X^{23} + X^{22} + X^{16} + X^{12} + X^{11} + X^{10} + \\
 &X^8 + X^7 + X^5 + X^4 + X^2 + X + 1
 \end{aligned}$$

To program these polynomial into the CRC generator, set the register bits as shown in Table 21-1.

Note that the appropriate positions are set to '1' to indicate they are used in the equation (for example, X26 and X23). The '0' bit required by the equation is always XORed; thus, X0 is a don't care. For a polynomial of length 32, it is assumed that the 32nd bit will be used. Therefore, the X<31:1> bits do not have the 32nd bit.

21.1.2 DATA INTERFACE

The module incorporates a FIFO that works with a variable data width. Input data width can be configured to any value between one and 32 bits using the DWIDTH<4:0> bits (CRCCON2<12:8>). When the data width is greater than 15, the FIFO is four words deep. When the DWIDTH bits are between 15 and 8, the FIFO is 8 words deep. When the DWIDTH bits are less than 8, the FIFO is 16 words deep.

The data for which the CRC is to be calculated must first be written into the FIFO. Even if the data width is less than 8, the smallest data element that can be written into the FIFO is one byte. For example, if DWIDTH is five, then the size of the data is DWIDTH + 1 or six. The data is written as a whole byte; the two unused upper bits are ignored by the module.

Once data is written into the MSb of the CRCDAT registers (that is, MSb as defined by the data width), the value of the VWORD<4:0> bits (CRCCON1<12:8>) increments by one. For example, if DWIDTH is 24, the VWORD bits will increment when bit 7 of CRCDATH is written. Therefore, CRCDATL must always be written to before CRCDATH.

The CRC engine starts shifting data when the CRCGO bit is set and the value of VWORD is greater than zero.

Each word is copied out of the FIFO into a buffer register, which decrements VWORD. The data is then shifted out of the buffer. The CRC engine continues shifting at a rate of two bits per instruction cycle, until VWORD reaches zero. This means that for a given data width, it takes half that number of instructions for each word to complete the calculation. For example, it takes 16 cycles to calculate the CRC for a single word of 32-bit data.

When VWORD reaches the maximum value for the configured value of DWIDTH (4, 8 or 16), the CRCFUL bit becomes set. When VWORD reaches zero, the CRCMPT bit becomes set. The FIFO is emptied and the VWORD<4:0> bits are set to '00000' whenever CRCEN is '0'.

At least one instruction cycle must pass after a write to CRCWDAT before a read of the VWORD bits is done.

TABLE 21-1: CRC SETUP EXAMPLES FOR 16 AND 32-BIT POLYNOMIALS

| CRC Control Bits | Bit Values | |
|------------------|---------------------|---------------------|
| | 16-Bit Polynomial | 32-Bit Polynomial |
| PLEN<4:0> | 01111 | 11111 |
| X<31:16> | 0000 0000 0000 0001 | 0000 0100 1100 0001 |
| X<15:0> | 0001 0000 0010 000X | 0001 1101 1011 011x |

PIC24FJ256DA210 FAMILY

[查询PIC24FJ256DA106供应商](#)

21.1.3 DATA SHIFT DIRECTION

The LENDIAN bit (CRCCON1<3>) is used to control the shift direction. By default, the CRC will shift data through the engine, MSb first. Setting LENDIAN (= 1) causes the CRC to shift data, LSb first. This setting allows better integration with various communication schemes and removes the overhead of reversing the bit order in software. Note that this only changes the direction the data is shifted into the engine. The result of the CRC calculation will still be a normal CRC result, not a reverse CRC result.

21.1.4 INTERRUPT OPERATION

The module generates an interrupt that is configurable by the user for either of two conditions.

If CRCISEL is '0', an interrupt is generated when the VWORD<4:0> bits make a transition from a value of '1' to '0'. If CRCISEL is '1', an interrupt will be generated after the CRC operation finishes and the module sets the CRCGO bit to '0'. Manually setting CRCGO to '0' will not generate an interrupt. Note that when an interrupt occurs, the CRC calculation would not yet be complete. The module will still need $(PLEN + 1)/2$ clock cycles after the interrupt is generated until the CRC calculation is finished.

21.1.5 TYPICAL OPERATION

To use the module for a typical CRC calculation:

1. Set the CRCEN bit to enable the module.
2. Configure the module for desired operation:
 - a) Program the desired polynomial using the CRCXORL and CRCXORH registers, and the PLEN<4:0> bits.
 - b) Configure the data width and shift direction using the DWIDTH and LENDIAN bits.
 - c) Select the desired interrupt mode using the CRCISEL bit.

3. Preload the FIFO by writing to the CRCDATL and CRCDATH registers until the CRCFUL bit is set or no data is left.
4. Clear old results by writing 00h to CRCWDATL and CRCWDATH. The CRCWDAT registers can also be left unchanged to resume a previously halted calculation.
5. Set the CRCGO bit to start calculation.
6. Write remaining data into the FIFO as space becomes available.
7. When the calculation completes, CRCGO is automatically cleared. An interrupt will be generated if CRCISEL = 1.
8. Read CRCWDATL and CRCWDATH for the result of the calculation.

There are eight registers used to control programmable CRC operation:

- CRCCON1
- CRCCON2
- CRCXORL
- CRCXORH
- CRCDATL
- CRCDATH
- CRCWDATL
- CRCWDATH

The CRCCON1 and CRCCON2 registers (Register 21-1 and Register 21-2) control the operation of the module and configure the various settings.

The CRCXOR registers (Register 21-3 and Register 21-4) select the polynomial terms to be used in the CRC equation. The CRCDAT and CRCWDAT registers are each register pairs that serve as buffers for the double-word input data, and CRC processed output, respectively.

PIC24FJ256DA210 FAMILY

[查询PIC24FJ256DA106供应商](#)

REGISTER 21-1: CRCCON1: CRC CONTROL 1 REGISTER

| | | | | | | | |
|--------|-----|-------|----------|----------|----------|----------|----------|
| R/W-0 | U-0 | R/W-0 | R-0, HSC | R-0, HSC | R-0, HSC | R-0, HSC | R-0, HSC |
| CRCCEN | — | CSIDL | VWORD4 | VWORD3 | VWORD2 | VWORD1 | VWORD0 |
| bit 15 | | | | | | | bit 8 |

| | | | | | | | |
|----------|----------|---------|-----------|---------|-----|-----|-------|
| R-0, HSC | R-1, HSC | R/W-0 | R/W-0, HC | R/W-0 | U-0 | U-0 | U-0 |
| CRCFUL | CRCMPT | CRCISEL | CRCGO | LENDIAN | — | — | — |
| bit 7 | | | | | | | bit 0 |

Legend:

| | | |
|-----------------------|---------------------------------------|------------------------------------|
| R = Readable bit | W = Writable bit | U = Unimplemented bit, read as '0' |
| -n = Value at POR | '1' = Bit is set | '0' = Bit is cleared |
| HC = Hardware Cleared | HSC = Hardware Settable/Clearable bit | x = Bit is unknown |

- bit 15 **CRCCEN:** CRC Enable bit
 1 = Enables module
 0 = Disables module; all state machines, pointers and CRCWDAT/CRCDATH reset; other SFRs are NOT reset
- bit 14 **Unimplemented:** Read as '0'
- bit 13 **CSIDL:** CRC Stop in Idle Mode bit
 1 = Discontinue module operation when device enters Idle mode
 0 = Continue module operation in Idle mode
- bit 12-8 **VWORD<4:0>:** Pointer Value bits
 Indicates the number of valid words in the FIFO. Has a maximum value of 8 when PLEN<4:0> ≥ 7 or 16 when PLEN<4:0> ≤ 7.
- bit 7 **CRCFUL:** FIFO Full bit
 1 = FIFO is full
 0 = FIFO is not full
- bit 6 **CRCMPT:** FIFO Empty bit
 1 = FIFO is empty
 0 = FIFO is not empty
- bit 5 **CRCISEL:** CRC Interrupt Selection bit
 1 = Interrupt on FIFO is empty; the final word of data is still shifting through the CRC
 0 = Interrupt on shift is complete and results are ready
- bit 4 **CRCGO:** Start CRC bit
 1 = Start CRC serial shifter
 0 = CRC serial shifter is turned off
- bit 3 **LENDIAN:** Data Shift Direction Select bit
 1 = Data word is shifted into the CRC, starting with the LSb (little endian)
 0 = Data word is shifted into the CRC, starting with the MSb (big endian)
- bit 2-0 **Unimplemented:** Read as '0'

PIC24FJ256DA210 FAMILY

[查询PIC24FJ256DA106供应商](#)

REGISTER 21-2: CRCCON2: CRC CONTROL 2 REGISTER

| | | | | | | | |
|--------|-----|-----|---------|---------|---------|---------|---------|
| U-0 | U-0 | U-0 | R/W-0 | R/W-0 | R/W-0 | R/W-0 | R/W-0 |
| — | — | — | DWIDTH4 | DWIDTH3 | DWIDTH2 | DWIDTH1 | DWIDTH0 |
| bit 15 | | | | | | | bit 8 |

| | | | | | | | |
|-------|-----|-----|-------|-------|-------|-------|-------|
| U-0 | U-0 | U-0 | R/W-0 | R/W-0 | R/W-0 | R/W-0 | R/W-0 |
| — | — | — | PLEN4 | PLEN3 | PLEN2 | PLEN1 | PLEN0 |
| bit 7 | | | | | | | bit 0 |

Legend:

R = Readable bit W = Writable bit U = Unimplemented bit, read as '0'
 -n = Value at POR '1' = Bit is set '0' = Bit is cleared x = Bit is unknown

- bit 15-13 **Unimplemented:** Read as '0'
- bit 12-8 **DWIDTH<4:0>:** Data Word Width Configuration bits
Configures the width of the data word (data word width – 1).
- bit 7-5 **Unimplemented:** Read as '0'
- bit 4-0 **PLEN<4:0>:** Polynomial Length Configuration bits
Configures the length of the polynomial (polynomial length – 1).

REGISTER 21-3: CRCXORL: CRC XOR POLYNOMIAL REGISTER, LOW BYTE

| | | | | | | | |
|--------|-------|-------|-------|-------|-------|-------|-------|
| R/W-0 | R/W-0 | R/W-0 | R/W-0 | R/W-0 | R/W-0 | R/W-0 | R/W-0 |
| X15 | X14 | X13 | X12 | X11 | X10 | X9 | X8 |
| bit 15 | | | | | | | bit 8 |

| | | | | | | | |
|-------|-------|-------|-------|-------|-------|-------|-------|
| R/W-0 | R/W-0 | R/W-0 | R/W-0 | R/W-0 | R/W-0 | R/W-0 | U-0 |
| X7 | X6 | X5 | X4 | X3 | X2 | X1 | — |
| bit 7 | | | | | | | bit 0 |

Legend:

R = Readable bit W = Writable bit U = Unimplemented bit, read as '0'
 -n = Value at POR '1' = Bit is set '0' = Bit is cleared x = Bit is unknown

- bit 15-1 **X<15:1>:** XOR of Polynomial Term x^n Enable bits
- bit 0 **Unimplemented:** Read as '0'

PIC24FJ256DA210 FAMILY

查询PIC24FJ256DA106供应商

REGISTER 21-4: CRCXORH: CRC XOR HIGH REGISTER

| | | | | | | | |
|--------|-------|-------|-------|-------|-------|-------|-------|
| R/W-0 | R/W-0 | R/W-0 | R/W-0 | R/W-0 | R/W-0 | R/W-0 | R/W-0 |
| X31 | X30 | X29 | X28 | X27 | X26 | X25 | X24 |
| bit 15 | | | | | | | bit 8 |

| | | | | | | | |
|-------|-------|-------|-------|-------|-------|-------|-------|
| R/W-0 | R/W-0 | R/W-0 | R/W-0 | R/W-0 | R/W-0 | R/W-0 | R/W-0 |
| X23 | X22 | X21 | X20 | X19 | X18 | X17 | X16 |
| bit 7 | | | | | | | bit 0 |

Legend:

R = Readable bit W = Writable bit U = Unimplemented bit, read as '0'
 -n = Value at POR '1' = Bit is set '0' = Bit is cleared x = Bit is unknown

bit 15-0 **X<31:16>**: XOR of Polynomial Term x^n Enable bits

REGISTER 21-5: CRCDATL: CRC DATA LOW REGISTER

| | | | | | | | |
|--------|--------|--------|--------|--------|--------|-------|-------|
| R/W-0 | R/W-0 | R/W-0 | R/W-0 | R/W-0 | R/W-0 | R/W-0 | R/W-0 |
| DATA15 | DATA14 | DATA13 | DATA12 | DATA11 | DATA10 | DATA9 | DATA8 |
| bit 15 | | | | | | | bit 8 |

| | | | | | | | |
|-------|-------|-------|-------|-------|-------|-------|-------|
| R/W-0 | R/W-0 | R/W-0 | R/W-0 | R/W-0 | R/W-0 | R/W-0 | R/W-0 |
| DATA7 | DATA6 | DATA5 | DATA4 | DATA3 | DATA2 | DATA1 | DATA0 |
| bit 7 | | | | | | | bit 0 |

Legend:

R = Readable bit W = Writable bit U = Unimplemented bit, read as '0'
 -n = Value at POR '1' = Bit is set '0' = Bit is cleared x = Bit is unknown

bit 15-0 **DATA<15:0>**: CRC Input Data bits
 Writing to this register fills the FIFO; reading from this register returns '0'.

REGISTER 21-6: CRCDATH: CRC DATA HIGH REGISTER

| | | | | | | | |
|--------|--------|--------|--------|--------|--------|-------|-------|
| R/W-0 | R/W-0 | R/W-0 | R/W-0 | R/W-0 | R/W-0 | R/W-0 | R/W-0 |
| DATA15 | DATA14 | DATA13 | DATA12 | DATA11 | DATA10 | DATA9 | DATA8 |
| bit 15 | | | | | | | bit 8 |

| | | | | | | | |
|-------|-------|-------|-------|-------|-------|-------|-------|
| R/W-0 | R/W-0 | R/W-0 | R/W-0 | R/W-0 | R/W-0 | R/W-0 | R/W-0 |
| DATA7 | DATA6 | DATA5 | DATA4 | DATA3 | DATA2 | DATA1 | DATA0 |
| bit 7 | | | | | | | bit 0 |

Legend:

R = Readable bit W = Writable bit U = Unimplemented bit, read as '0'
 -n = Value at POR '1' = Bit is set '0' = Bit is cleared x = Bit is unknown

bit 15-0 **DATA<15:0>**: CRC Input Data bits
 Writing to this register fills the FIFO; reading from this register returns '0'.

PIC24FJ256DA210 FAMILY

[查询PIC24FJ256DA106供应商](#)

REGISTER 21-7: CRCWDATL: CRC SHIFT LOW REGISTER

| | | | | | | | |
|------------|------------|------------|------------|------------|------------|------------|------------|
| R/W-0, HSC | R/W-0, HSC | R/W-0, HSC | R/W-0, HSC | R/W-0, HSC | R/W-0, HSC | R/W-0, HSC | R/W-0, HSC |
| SDATA15 | SDATA14 | SDATA13 | SDATA12 | SDATA11 | SDATA10 | SDATA9 | SDATA8 |
| bit 15 | | | | | | | bit 8 |

| | | | | | | | |
|------------|------------|------------|------------|------------|------------|------------|------------|
| R/W-0, HSC | R/W-0, HSC | R/W-0, HSC | R/W-0, HSC | R/W-0, HSC | R/W-0, HSC | R/W-0, HSC | R/W-0, HSC |
| SDATA7 | SDATA6 | SDATA5 | SDATA4 | SDATA3 | SDATA2 | SDATA1 | SDATA0 |
| bit 7 | | | | | | | bit 0 |

| | | | |
|-------------------|---------------------------------------|------------------------------------|--------------------|
| Legend: | HSC = Hardware Settable/Clearable bit | | |
| R = Readable bit | W = Writable bit | U = Unimplemented bit, read as '0' | |
| -n = Value at POR | '1' = Bit is set | '0' = Bit is cleared | x = Bit is unknown |

bit 15-0 **SDATA<15:0>**: CRC Shift Register bits
 Writing to this register writes to the CRC Shift register through the CRC write bus. Reading from this register reads the CRC read bus.

REGISTER 21-8: CRCWDATH: CRC SHIFT HIGH REGISTER

| | | | | | | | |
|------------|------------|------------|------------|------------|------------|------------|------------|
| R/W-0, HSC | R/W-0, HSC | R/W-0, HSC | R/W-0, HSC | R/W-0, HSC | R/W-0, HSC | R/W-0, HSC | R/W-0, HSC |
| SDATA31 | SDATA30 | SDATA29 | SDATA28 | SDATA27 | SDATA26 | SDATA25 | SDATA24 |
| bit 15 | | | | | | | bit 8 |

| | | | | | | | |
|------------|------------|------------|------------|------------|------------|------------|------------|
| R/W-0, HSC | R/W-0, HSC | R/W-0, HSC | R/W-0, HSC | R/W-0, HSC | R/W-0, HSC | R/W-0, HSC | R/W-0, HSC |
| SDATA23 | SDATA22 | SDATA21 | SDATA20 | SDATA19 | SDATA18 | SDATA17 | SDATA16 |
| bit 7 | | | | | | | bit 0 |

| | | | |
|-------------------|---------------------------------------|------------------------------------|--------------------|
| Legend: | HSC = Hardware Settable/Clearable bit | | |
| R = Readable bit | W = Writable bit | U = Unimplemented bit, read as '0' | |
| -n = Value at POR | '1' = Bit is set | '0' = Bit is cleared | x = Bit is unknown |

bit 15-0 **SDATA<31:16>**: CRC Input Data bits
 Writing to this register writes to the CRC Shift register through the CRC write bus. Reading from this register reads the CRC read bus.

PIC24FJ256DA210 FAMILY

[查询PIC24FJ256DA106供应商](#)

NOTES:

PIC24FJ256DA210 FAMILY

[查询PIC24FJ256DA106供应商](#)

22.0 GRAPHICS CONTROLLER MODULE (GFX)

Note: This data sheet summarizes the features of this group of PIC24F devices. It is not intended to be a comprehensive reference source. For more information, refer to the “PIC24F Family Reference Manual”, **Section 43. “Graphics Controller Module (GFX)”** (DS39731). The information in this data sheet supersedes the information in the FRM.

The Graphics Controller (GFX) module is specifically designed to directly interface with the display glasses, with a built-in analog drive, to individually control pixels in the screen. The module also provides an accelerated rendering of vertical and horizontal lines, rectangles, copying of rectangular area between different locations on the screen, drawing texts and decompressing packed data. The use of the accelerated rendering is performed using command registers. Once initiated, the hardware will perform the rendering, and the software can either poll the status, or use the interrupts to continue rendering of the succeeding shapes.

Key features of the GFX module include:

- Direct interface to three categories of display glasses:
 - Monochrome STN
 - Color STN
 - Color TFT
- Programmable vertical and horizontal synchronization signals' timing and display clock frequency to meet display's frame rates
- Optional internal or external display buffer to accommodate different types of display resolution
- Graphic hardware accelerators:
 - Character Graphics Processing Unit (CHRGPU)
 - Rectangle Copy Graphics Processing Unit (RCCGPU)
 - Inflate Processing Unit (IPU)
- 256 Entries Color Look-up Table (CLUT)
- Supports 1/2/4/8/16 bits-per-pixel (bpp) color depth
- Programmable display resolution
- Supports multiple display interfaces:
 - 4/8/16-bit Monochrome STN
 - 4/8/16-bit Color STN
 - 9/12/18/24-bit color TFT (18 and 24-bit displays are connected as 16-bit 5-6-5 RGB color format)

FIGURE 22-1: GRAPHICS MODULE OVERVIEW

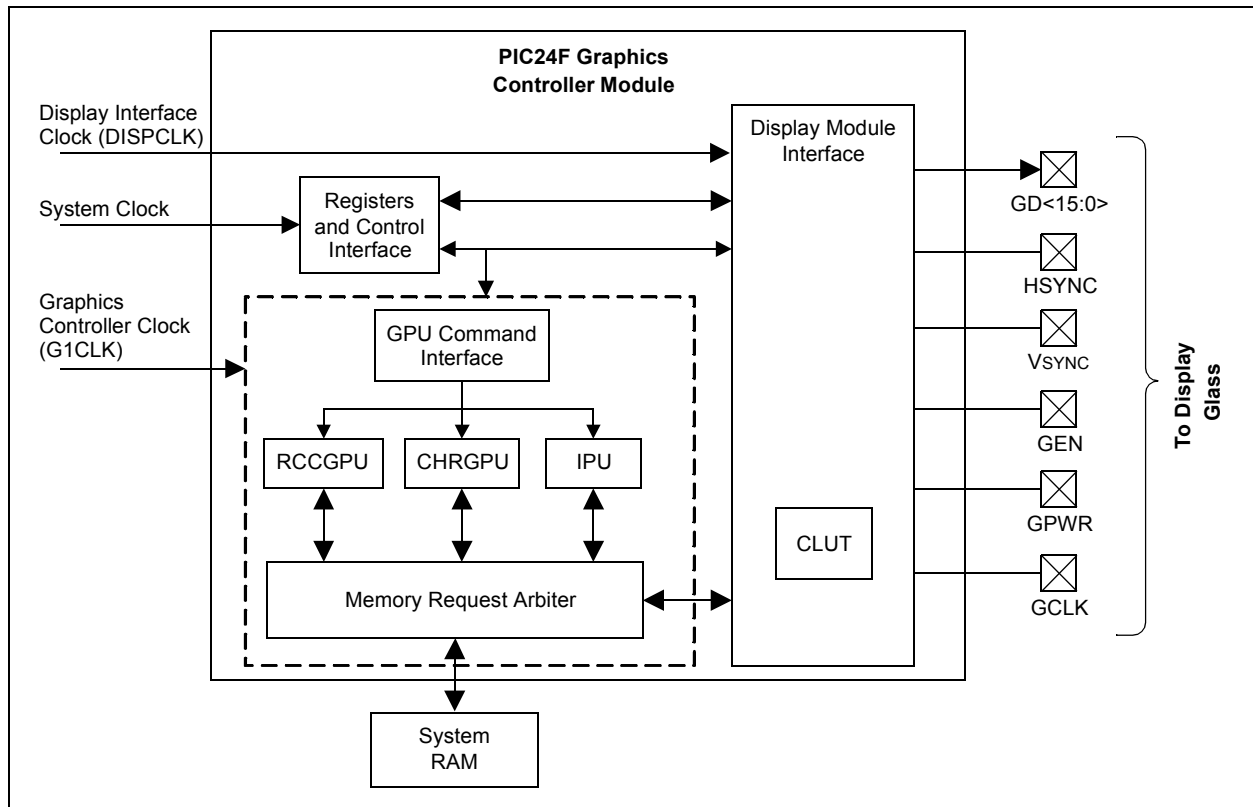

PIC24FJ256DA210 FAMILY

查询PIC24FJ256DA106供应商
22.1 GFX Module Registers

REGISTER 22-1: G1CMDL: GPU COMMAND LOW REGISTER

| | | | | | | | |
|--------|--------|--------|--------|--------|--------|-------|-------|
| R/W-0 | R/W-0 | R/W-0 | R/W-0 | R/W-0 | R/W-0 | R/W-0 | R/W-0 |
| GCMD15 | GCMD14 | GCMD13 | GCMD12 | GCMD11 | GCMD10 | GCMD9 | GCMD8 |
| bit 15 | | | | | | | bit 8 |

| | | | | | | | |
|-------|-------|-------|-------|-------|-------|-------|-------|
| R/W-0 | R/W-0 | R/W-0 | R/W-0 | R/W-0 | R/W-0 | R/W-0 | R/W-0 |
| GCMD7 | GCMD6 | GCMD5 | GCMD4 | GCMD3 | GCMD2 | GCMD1 | GCMD0 |
| bit 7 | | | | | | | bit 0 |

Legend:

R = Readable bit W = Writable bit U = Unimplemented bit, read as '0'
 -n = Value at POR '1' = Bit is set '0' = Bit is cleared x = Bit is unknown

bit 15-0 **GCMD<15:0>**: Low GPU Command bits

The full 32-bit command is defined by G1CMDH and G1CMDL (GCMD<31:0>). Writes to this register will not trigger the loading of GCMD <31:0> to the command FIFO. For command FIFO loading, see the G1CMDH register description.

REGISTER 22-2: G1CMDH: GPU COMMAND HIGH REGISTER

| | | | | | | | |
|--------|--------|--------|--------|--------|--------|--------|--------|
| R/W-0 | R/W-0 | R/W-0 | R/W-0 | R/W-0 | R/W-0 | R/W-0 | R/W-0 |
| GCMD31 | GCMD30 | GCMD29 | GCMD28 | GCMD27 | GCMD26 | GCMD25 | GCMD24 |
| bit 15 | | | | | | | bit 8 |

| | | | | | | | |
|--------|--------|--------|--------|--------|--------|--------|--------|
| R/W-0 | R/W-0 | R/W-0 | R/W-0 | R/W-0 | R/W-0 | R/W-0 | R/W-0 |
| GCMD23 | GCMD22 | GCMD21 | GCMD20 | GCMD19 | GCMD18 | GCMD17 | GCMD16 |
| bit 7 | | | | | | | bit 0 |

Legend:

R = Readable bit W = Writable bit U = Unimplemented bit, read as '0'
 -n = Value at POR '1' = Bit is set '0' = Bit is cleared x = Bit is unknown

bit 15-0 **GCMD<31:16>**: High GPU Command bits

The full 32-bit command is defined by G1CMDH and G1CMDL (GCMD<31:0>). A word write to the G1CMDH register triggers the loading of GCMD<31:0> to the command FIFO. Byte writes to the G1CMDH are allowed but only a high byte write will trigger the command loading to the FIFO. Low byte write to this register will only update the G1CMDH<7:0> bits.

PIC24FJ256DA210 FAMILY

[查询PIC24FJ256DA106供应商](#)

REGISTER 22-3: G1CON1: DISPLAY CONTROL REGISTER 1

| | | | | | | | |
|--------|-----|--------|----------|----------|----------|----------|----------|
| R/W-0 | U-0 | R/W-0 | R/W-0 | R/W-0 | R/W-0 | R/W-0 | R/W-0 |
| G1EN | — | G1SIDL | GCMDWMK4 | GCMDWMK3 | GCMDWMK2 | GCMDWMK1 | GCMDWMK0 |
| bit 15 | | | | | | | bit 8 |

| | | | | | | | |
|--------|--------|--------|----------|----------|----------|----------|----------|
| R/W-0 | R/W-0 | R/W-0 | R-0, HSC | R-0, HSC | R-0, HSC | R-0, HSC | R-0, HSC |
| PUBPP2 | PUBPP1 | PUBPP0 | GCMDCNT4 | GCMDCNT3 | GCMDCNT2 | GCMDCNT1 | GCMDCNT0 |
| bit 7 | | | | | | | bit 0 |

| | | | |
|-------------------|---------------------------------------|------------------------------------|--------------------|
| Legend: | HSC = Hardware Settable/Clearable bit | | |
| R = Readable bit | W = Writable bit | U = Unimplemented bit, read as '0' | |
| -n = Value at POR | '1' = Bit is set | '0' = Bit is cleared | x = Bit is unknown |

- bit 15 **G1EN:** Module Enable bit
 1 = Display module is enabled
 0 = Display module is disabled
- bit 14 **Unimplemented:** Read as '0'
- bit 13 **G1SIDL:** Stop in Idle bit
 1 = Display module stops in Idle mode
 0 = Display module does not stop in Idle mode
- bit 12-8 **GCMDWMK<4:0>:** Command FIFO Watermark bits
 Sets the command watermark level that triggers the CMDLVIF interrupt and sets the CMDLV flag;
 GCMDWMK<4:0> (10000 = Reserved)
 10000 = If the number of commands present in the FIFO goes from 16 to 15 commands, the CMDLVIF
 interrupt will trigger and the CMDLV flag will be set
 01111 = If the number of commands present in the FIFO goes from 15 to 14 commands, CMDLVIF
 interrupt will trigger and CMDLV flag will be set
 .
 .
 .
 00001 = If the number of commands present in the FIFO goes from 1 to 0 commands, the CMDLVIF
 interrupt will trigger and the CMDLV flag will be set
 00000 = CMDLVIF interrupt will not trigger and the CMDLV flag will not be set
- bit 7-5 **PUBPP<2:0>:** GPU bits-per-pixel (bpp) Setting bits
 Other = Reserved
 100 = 16 bits-per-pixel
 011 = 8 bits-per-pixel
 010 = 4 bits-per-pixel
 001 = 2 bits-per -pixel
 000 = 1-bit -per-pixel
- bit 4-0 **GCMDCNT<4:0>:** Command FIFO Occupancy Status bits
 When the FIFO is full, any additional commands written to the FIFO are discarded.
 10000 = 16 commands are present in the FIFO
 01111 = 15 commands are present in the FIFO
 .
 .
 .
 0001 = 1 command is present in the FIFO
 0000 = 0 command is present in the FIFO

PIC24FJ256DA210 FAMILY

[查询PIC24FJ256DA106供应商](#)

REGISTER 22-4: G1CON2: DISPLAY CONTROL REGISTER 2

| | | | | | | | |
|----------|----------|----------|----------|-----|-----|---------|---------|
| R/W-0 | R/W-0 | R/W-0 | R/W-0 | U-0 | U-0 | R/W-0 | R/W-0 |
| DPGWDTH1 | DPGWDTH0 | DPSTGER1 | DPSTGER0 | — | — | DPTEST1 | DPTEST0 |
| bit 15 | | | | | | bit 8 | |

| | | | | | | | |
|--------|--------|--------|-----|-----|---------|---------|---------|
| R/W-0 | R/W-0 | R/W-0 | U-0 | U-0 | R/W-0 | R/W-0 | R/W-0 |
| DPBPP2 | DPBPP1 | DPBPP0 | — | — | DPMODE2 | DPMODE1 | DPMODE0 |
| bit 7 | | | | | | bit 0 | |

Legend:

R = Readable bit

W = Writable bit

U = Unimplemented bit, read as '0'

-n = Value at POR

'1' = Bit is set

'0' = Bit is cleared

x = Bit is unknown

bit 15-14 **DPGWDTH<1:0>**: STN Display Glass Data Width bits

11 = Reserved

10 = 16 bits wide

01 = 8 bits wide

00 = 4 bits wide

These bits have no effect on TFT mode. TFT display glass data width is always assumed to be 16 bits wide.

bit 13-12 **DPSTGER<1:0>**: Display Data Timing Stagger bits

11 = Delays of the display data are staggered in groups:

Bit group 0: 0 4 8 12 – not delayed

Bit group 1: 1 5 9 13 – delayed by ½ GPUCLK cycle

Bit group 2: 2 6 10 14 – delayed by full GPUCLK cycle

Bit group 3: 3 7 11 15 – delayed by 1 ½ GPUCLK cycle

10 = Even bits of the display data are delayed by 1 full GPUCLK cycle; odd bits are not delayed

01 = Odd bits of the display data are delayed by ½ GPUCLK cycle; even bits are not delayed

00 = Display data timing is all synchronized on one clock GPUCLK edge

bit 11-10 **Unimplemented**: Read as '0'

bit 9-8 **DPTEST<1:0>**: Display Test Pattern Generator bits

11 = Borders

10 = Bars

01 = Black screen

00 = Normal Display mode; test patterns are off

bit 7-5 **DPBPP<2:0>**: Display bits-per-pixel Setting bits

This setting must match the GPU bits-per-pixel set in PUBPP<2:0> (G1CON1<7:5>).

100 = 16 bits-per-pixel

011 = 8 bits-per-pixel

010 = 4 bits-per-pixel

001 = 2 bits-per-pixel

000 = 1 bit-per-pixel

Other = Reserved

bit 4-3 **Unimplemented**: Read as '0'

bit 2-0 **DPMODE<2:0>**: Display Glass Type bits

011 = Color STN type

010 = Mono STN type

001 = TFT type

000 = Display off

Other = Reserved

PIC24FJ256DA210 FAMILY

[查询PIC24FJ256DA106供应商](#)

REGISTER 22-5: G1CON3: DISPLAY CONTROL REGISTER 3

| | | | | | | | |
|--------|-----|-----|-----|-----|-----|---------|---------|
| U-0 | U-0 | U-0 | U-0 | U-0 | U-0 | R/W-0 | R/W-0 |
| — | — | — | — | — | — | DPPINOE | DPPOWER |
| bit 15 | | | | | | bit 8 | |

| | | | | | | | |
|----------|---------|---------|---------|---------|--------|--------|--------|
| R/W-0 | R/W-0 | R/W-0 | R/W-0 | R/W-0 | R/W-0 | R/W-0 | R/W-0 |
| DPCLKPOL | DPENPOL | DPVSPOL | DPHSPOL | DPPWROE | DPENOE | DPVSOE | DPHSOE |
| bit 7 | | | | | | bit 0 | |

Legend:

R = Readable bit W = Writable bit U = Unimplemented bit, read as '0'
 -n = Value at POR '1' = Bit is set '0' = Bit is cleared x = Bit is unknown

- bit 15-10 **Unimplemented:** Read as '0'
- bit 9 **DPPINOE:** Display Pin Output Pad Enable bit
 DPPINOE is the master output enable and must be set to allow GDBEN<15:0>, DPENOE, DPPWROE, DPVSOE and DPHSOE to enable the associated pads
 1 = Enable display output pads
 0 = Disable display output signals as set by GDBEN<15:0>
 Pins used by the signals are assigned to the next enabled module that uses the same pins.
 For data signals, GDBEN<15:0> can be used to disable or enable specific data signals while DPPINOE is set.
- bit 8 **DPPOWER:** Display Power-up Power-Down Sequencer Control bit
 Refer to the "PIC24F Family Reference Manual", Section 43. "Graphics Controller Module (GFX)" for details.
 1 = Set Display Power Sequencer Control port (GPWR) to '1'
 0 = Set Power Control Sequencer signal (GPWR) '0'
- bit 7 **DPCLKPOL:** Display Glass Clock (GCLK) Polarity bit
 1 = Display latches data on the positive edge of GCLK
 0 = Display latches data on the negative edge of GCLK
- bit 6 **DPENPOL:** Display Enable Signal (GEN) Polarity bit
For TFT mode (DPMODE (G1CON2<2:0>) = 001):
 1 = Active-high (GEN)
 0 = Active-low (GEN)
For STN mode (DPMODE (G1CON2<2:0>) = 010 or 011):
 1 = GEN connects to the shift clock input of the display (Shift Clock mode)
 0 = GEN connects to the MOD input of the display (Line/Frame Toggle mode)
- bit 5 **DPVSPOL:** Display Vertical Synchronization (VSYNC) Polarity bit
 1 = Active-high (VSYNC)
 0 = Active-low (VSYNC)
- bit 4 **DPHSPOL:** Display Horizontal Synchronization (HSYNC) Polarity bit
 1 = Active-high (HSYNC)
 0 = Active-low (HSYNC)
- bit 3 **DPPWROE:** Display Power-up/Power-Down Sequencer Control port (GPWR) enable bit
 1 = GPWR port is enabled (pin controlled by the DPPOWER bit (G1CON3<8>))
 0 = GPWR port is disabled (pin can be used as an ordinary I/O)
- bit 2 **DPENOE:** Display Enable Port Enable bit
 1 = GEN port is enabled
 0 = GEN port is disabled

PIC24FJ256DA210 FAMILY

查询PIC24FJ256DA106供应商

REGISTER 22-5: G1CON3: DISPLAY CONTROL REGISTER 3 (CONTINUED)

- bit 1 **DPVSOE:** Display Vertical Synchronization Port Enable bit
 1 = VSYNC port is enabled
 0 = VSYNC port is disabled
- bit 0 **DPHSOE:** Display Horizontal Synchronization Port Enable bit
 1 = HSYNC port is enabled
 0 = HSYNC port is disabled

REGISTER 22-6: G1STAT: GFX STATUS REGISTER

| | | | | | | | |
|----------|-----|-----|-----|-----|-----|-----|-------|
| R-0, HSC | U-0 | U-0 | U-0 | U-0 | U-0 | U-0 | U-0 |
| PUBUSY | — | — | — | — | — | — | — |
| bit 15 | | | | | | | bit 8 |

| | | | | | | | |
|----------|----------|----------|----------|----------|----------|----------|----------|
| R-0, HSC | R-0, HSC | R-0, HSC | R-0, HSC | R-0, HSC | R-0, HSC | R-0, HSC | R-0, HSC |
| IPUBUSY | RCCBUSY | CHRBUSY | VMRGN | HMRGN | CMDLV | CMDFUL | CMDMPT |
| bit 7 | | | | | | | bit 0 |

| | |
|-------------------|--|
| Legend: | HSC = Hardware Settable/Clearable bit |
| R = Readable bit | W = Writable bit U = Unimplemented bit, read as '0' |
| -n = Value at POR | '1' = Bit is set '0' = Bit is cleared x = Bit is unknown |

- bit 15 **PUBUSY:** Processing Units are Busy Status bit
 This bit is logically equivalent to the ORed combination of IPUBUSY, RCCBUSY or CHRBUSY.
 1 = At least one processing unit is busy
 0 = None of the processing units are busy
- bit 14-8 **Unimplemented:** Read as '0'
- bit 7 **IPUBUSY:** Inflate Processing Unit Busy Status bit
 1 = IPU is busy
 0 = IPU is not busy
- bit 6 **RCCBUSY:** Rectangle Copy Graphics Processing Unit Busy Status bit
 1 = RCCGPU is busy
 0 = RCCGPU is not busy
- bit 5 **CHRBUSY:** Character Graphics Processing Unit Busy Status bit
 1 = CHRGPU is busy
 0 = CHRGPU is not busy
- bit 4 **VMRGN:** Vertical Blanking Status bit
 1 = Display interface is in the vertical blanking period
 0 = Display interface is not in the vertical blanking period
- bit 3 **HMRGN:** Horizontal Blanking Status bit
 1 = Display interface is in the horizontal blanking period
 0 = Display interface is not in the horizontal blanking period
- bit 2 **CMDLV:** Command Watermark Level Status bit
 The number of commands in the command FIFO changed from equal (=) to the command watermark value to less than (<) the Command Watermark value set in CMDWMK (G1CON1<12:8>) register bits.
 1 = Command in FIFO is less than the set CMDWMK value
 0 = Command in FIFO is equal to or greater than the set CMDWMK value
- bit 1 **CMDFUL:** Command FIFO Full Status bit
 1 = Command FIFO is full
 0 = Command FIFO is not full
- bit 0 **CMDMPT:** Command FIFO Empty Status bit
 1 = Command FIFO is empty
 0 = Command FIFO is not empty

PIC24FJ256DA210 FAMILY

[查询PIC24FJ256DA106供应商](#)

REGISTER 22-7: G1IE: GFX INTERRUPT ENABLE REGISTER

| | | | | | | | |
|--------|-----|-----|-----|-----|-----|-----|-------|
| R/W-0 | U-0 | U-0 | U-0 | U-0 | U-0 | U-0 | U-0 |
| PUIE | — | — | — | — | — | — | — |
| bit 15 | | | | | | | bit 8 |

| | | | | | | | |
|-------|-------|-------|---------|---------|---------|----------|----------|
| R/W-0 | R/W-0 | R/W-0 | R/W-0 | R/W-0 | R/W-0 | R/W-0 | R/W-0 |
| IPUIE | RCCIE | CHRIE | VMRGNIE | HMRGNIE | CMDLVIE | CMDFULIE | CMDMPTIE |
| bit 7 | | | | | | | bit 0 |

Legend:

| | | |
|-------------------|------------------|--|
| R = Readable bit | W = Writable bit | U = Unimplemented bit, read as '0' |
| -n = Value at POR | '1' = Bit is set | '0' = Bit is cleared x = Bit is unknown |

- bit 15 **PUIE:** Processing Units Complete Interrupt Enable bit
 1 = Enables the PU complete interrupt
 0 = Disables the PU complete interrupt
- bit 14-8 **Unimplemented:** Read as '0'
- bit 7 **IPUIE:** Inflate Processing Unit Complete Interrupt Enable bit
 1 = Enables the IPU complete interrupt
 0 = Disables the IPU complete interrupt
- bit 6 **RCCIE:** Rectangle Copy Graphics Processing Unit Complete Interrupt bit
 1 = Enables the RCCGPU complete interrupt
 0 = Disables the RCCGPU complete interrupt
- bit 5 **CHRIE:** Character Graphics Processing Unit Busy Interrupt bit
 1 = Enables the CHRGPU busy interrupt
 0 = Disables the CHRGPU busy interrupt
- bit 4 **VMRGNIE:** Vertical Blanking Interrupt Enable bit
 1 = Enables the vertical blanking period interrupt
 0 = Disables the vertical blanking period interrupt
- bit 3 **HMRGNIE:** Horizontal Blanking Interrupt Enable bit
 1 = Enables the horizontal blanking period interrupt
 0 = Disables the horizontal blanking period interrupt
- bit 2 **CMDLVIE:** Command Watermark Interrupt Enable bit
 1 = Enables the command watermark interrupt bit
 0 = Disables the command watermark interrupt bit
- bit 1 **CMDFULIE:** Command FIFO Full Interrupt Enable bit
 1 = Enables the command FIFO full interrupt
 0 = Disables the command FIFO full interrupt
- bit 0 **CMDMPTIE:** Command FIFO Empty Interrupt Enable bit
 1 = Enables the command FIFO empty interrupt
 0 = Disables the command FIFO empty interrupt

PIC24FJ256DA210 FAMILY

[查询PIC24FJ256DA106供应商](#)

REGISTER 22-8: G1IR: GFX INTERRUPT STATUS REGISTER

| | | | | | | | |
|-----------|-----|-----|-----|-----|-----|-----|-------|
| R/W-0, HS | U-0 | U-0 | U-0 | U-0 | U-0 | U-0 | U-0 |
| PUIF | — | — | — | — | — | — | — |
| bit 15 | | | | | | | bit 8 |

| | | | | | | | |
|----------------------|----------------------|----------------------|-----------|-----------|-----------|-----------|-----------|
| R/W-0, HS | R/W-0, HS | R/W-0, HS | R/W-0, HS | R/W-0, HS | R/W-0, HS | R/W-0, HS | R/W-0, HS |
| IPIUF ⁽¹⁾ | RCCIF ⁽¹⁾ | CHRIF ⁽¹⁾ | VMRGNIF | HMRGNIF | CMDLVIF | CMDFULIF | CMDMPTIF |
| bit 7 | | | | | | | bit 0 |

| | |
|-------------------|------------------------------------|
| Legend: | HS = Hardware Settable bit |
| R = Readable bit | W = Writable bit |
| -n = Value at POR | '1' = Bit is set |
| | U = Unimplemented bit, read as '0' |
| | '0' = Bit is cleared |
| | x = Bit is unknown |

- bit 15 **PUIF:** Processing Units Complete Interrupt Flag bit
 PUIF is an ORed combination of IPIUF, RCCIF and CHRIF.
 1 = One or more PUs completed command execution (must be cleared in software)
 0 = All PUs are Idle or busy completing command execution
- bit 14-8 **Unimplemented:** Read as '0'
- bit 7 **IPIUF:** Inflate Processing Unit Complete Interrupt Flag bit⁽¹⁾
 1 = IPU completed command execution (must be cleared in software)
 0 = IPU is Idle or busy completing command execution
- bit 6 **RCCIF:** Rectangle Copy Graphics Processing Unit Complete Interrupt Flag bit⁽¹⁾
 1 = RCCGPU completed command execution (must be cleared in software)
 0 = RCCGPU is Idle or busy completing command execution
- bit 5 **CHRIF:** Character Graphics Processing Unit Complete Interrupt Flag bit⁽¹⁾
 1 = CHRGPU completed command execution (must be cleared in software)
 0 = CHRGPU is Idle or busy completing command execution
- bit 4 **VMRGNIF:** Vertical Blanking Interrupt Flag bit
 1 = Display interface is in the vertical blanking period (must be cleared in software)
 0 = Display interface is not in the vertical blanking period
- bit 3 **HMRGNIF:** Horizontal Blanking Interrupt Flag bit
 1 = Display interface is in the horizontal blanking period (must be cleared in software)
 0 = Display interface is not in the horizontal blanking period
- bit 2 **CMDLVIF:** Command Watermark Interrupt Flag bit
 1 = Command watermark level is reached (must be cleared in software)
 0 = Command watermark level is not yet reached
- bit 1 **CMDFULIF:** Command FIFO Full Interrupt Flag bit
 1 = Command FIFO is full (must be cleared in software)
 0 = Command FIFO is not full
- bit 0 **CMDMPTIF:** Command FIFO Empty Interrupt Flag bit
 1 = Command FIFO is empty (must be cleared in software)
 0 = Command FIFO is not empty

Note 1: The logic of each Processing Unit Status bit is the reverse of the PUIF. This provides flexibility on software code utilizing the processing units.

PIC24FJ256DA210 FAMILY

查询PIC24FJ256DA106供应商

REGISTER 22-9: G1W1ADRL: GPU WORK AREA 1 START ADDRESS REGISTER LOW

| | | | | | | | |
|---------|---------|---------|---------|---------|---------|--------|--------|
| R/W-0 | R/W-0 | R/W-0 | R/W-0 | R/W-0 | R/W-0 | R/W-0 | R/W-0 |
| W1ADR15 | W1ADR14 | W1ADR13 | W1ADR12 | W1ADR11 | W1ADR10 | W1ADR9 | W1ADR8 |
| bit 15 | | | | | | | bit 8 |

| | | | | | | | |
|--------|--------|--------|--------|--------|--------|--------|--------|
| R/W-0 | R/W-0 | R/W-0 | R/W-0 | R/W-0 | R/W-0 | R/W-0 | R/W-0 |
| W1ADR7 | W1ADR6 | W1ADR5 | W1ADR4 | W1ADR3 | W1ADR2 | W1ADR1 | W1ADR0 |
| bit 7 | | | | | | | bit 0 |

Legend:

R = Readable bit W = Writable bit U = Unimplemented bit, read as '0'
 -n = Value at POR '1' = Bit is set '0' = Bit is cleared x = Bit is unknown

bit 15-0 **W1ADR<15:0>**: GPU Work Area 1 Start Address Low bits
 Work area address must point to an even byte address in memory.

REGISTER 22-10: G1W1ADRH: GPU WORK AREA 1 START ADDRESS REGISTER HIGH

| | | | | | | | |
|--------|-----|-----|-----|-----|-----|-----|-------|
| U-0 | U-0 | U-0 | U-0 | U-0 | U-0 | U-0 | U-0 |
| — | — | — | — | — | — | — | — |
| bit 15 | | | | | | | bit 8 |

| | | | | | | | |
|---------|---------|---------|---------|---------|---------|---------|---------|
| R/W-0 | R/W-0 | R/W-0 | R/W-0 | R/W-0 | R/W-0 | R/W-0 | R/W-0 |
| W1ADR23 | W1ADR22 | W1ADR21 | W1ADR20 | W1ADR19 | W1ADR18 | W1ADR17 | W1ADR16 |
| bit 7 | | | | | | | bit 0 |

Legend:

R = Readable bit W = Writable bit U = Unimplemented bit, read as '0'
 -n = Value at POR '1' = Bit is set '0' = Bit is cleared x = Bit is unknown

bit 15-8 **Unimplemented:** Read as '0'
 bit 7-0 **W1ADR<23:16>**: GPU Work Area 1 Start Address High bits
 Work area address must point to an even byte address in memory.

REGISTER 22-11: G1W2ADRL: GPU WORK AREA 2 START ADDRESS REGISTER LOW

| | | | | | | | |
|---------|---------|---------|---------|---------|---------|--------|--------|
| R/W-0 | R/W-0 | R/W-0 | R/W-0 | R/W-0 | R/W-0 | R/W-0 | R/W-0 |
| W2ADR15 | W2ADR14 | W2ADR13 | W2ADR12 | W2ADR11 | W2ADR10 | W2ADR9 | W2ADR8 |
| bit 15 | | | | | | | bit 8 |

| | | | | | | | |
|--------|--------|--------|--------|--------|--------|--------|--------|
| R/W-0 | R/W-0 | R/W-0 | R/W-0 | R/W-0 | R/W-0 | R/W-0 | R/W-0 |
| W2ADR7 | W2ADR6 | W2ADR5 | W2ADR4 | W2ADR3 | W2ADR2 | W2ADR1 | W2ADR0 |
| bit 7 | | | | | | | bit 0 |

Legend:

R = Readable bit W = Writable bit U = Unimplemented bit, read as '0'
 -n = Value at POR '1' = Bit is set '0' = Bit is cleared x = Bit is unknown

bit 15-0 **W2ADR<15:0>**: GPU Work Area 2 Start Address Low bits
 Work area address must point to an even byte address in memory.

PIC24FJ256DA210 FAMILY

[查询PIC24FJ256DA106供应商](#)

REGISTER 22-12: G1W2ADRH: GPU WORK AREA 2 START ADDRESS REGISTER HIGH

| | | | | | | | |
|--------|-----|-----|-----|-----|-----|-----|-------|
| U-0 | U-0 | U-0 | U-0 | U-0 | U-0 | U-0 | U-0 |
| — | — | — | — | — | — | — | — |
| bit 15 | | | | | | | bit 8 |

| | | | | | | | |
|---------|---------|---------|---------|---------|---------|---------|---------|
| R/W-0 | R/W-0 | R/W-0 | R/W-0 | R/W-0 | R/W-0 | R/W-0 | R/W-0 |
| W2ADR23 | W2ADR22 | W2ADR21 | W2ADR20 | W2ADR19 | W2ADR18 | W2ADR17 | W2ADR16 |
| bit 7 | | | | | | | bit 0 |

Legend:

R = Readable bit W = Writable bit U = Unimplemented bit, read as '0'
 -n = Value at POR '1' = Bit is set '0' = Bit is cleared x = Bit is unknown

bit 15-8 **Unimplemented:** Read as '0'
 bit 7-0 **W2ADR<23:16>:** GPU Work Area 2 Start Address High bits
 Work area address must point to an even byte address in memory.

REGISTER 22-13: G1PUW: GPU WORK AREA WIDTH REGISTER

| | | | | | | | |
|--------|-----|-----|-----|-----|-------|-------|-------|
| U-0 | U-0 | U-0 | U-0 | U-0 | R/W-0 | R/W-0 | R/W-0 |
| — | — | — | — | — | PUW10 | PUW9 | PUW8 |
| bit 15 | | | | | | | bit 8 |

| | | | | | | | |
|-------|-------|-------|-------|-------|-------|-------|-------|
| R/W-0 | R/W-0 | R/W-0 | R/W-0 | R/W-0 | R/W-0 | R/W-0 | R/W-0 |
| PUW7 | PUW6 | PUW5 | PUW4 | PUW3 | PUW2 | PUW1 | PUW0 |
| bit 7 | | | | | | | bit 0 |

Legend:

R = Readable bit W = Writable bit U = Unimplemented bit, read as '0'
 -n = Value at POR '1' = Bit is set '0' = Bit is cleared x = Bit is unknown

bit 15-11 **Unimplemented:** Read as '0'
 bit 10-0 **PUW<10:0>:** GPU Work Area Width bits (in pixels)

REGISTER 22-14: G1PUH: GPU WORK AREA HEIGHT REGISTER

| | | | | | | | |
|--------|-----|-----|-----|-----|-------|-------|-------|
| U-0 | U-0 | U-0 | U-0 | U-0 | R/W-0 | R/W-0 | R/W-0 |
| — | — | — | — | — | PUH10 | PUH9 | PUH8 |
| bit 15 | | | | | | | bit 8 |

| | | | | | | | |
|-------|-------|-------|-------|-------|-------|-------|-------|
| R/W-0 | R/W-0 | R/W-0 | R/W-0 | R/W-0 | R/W-0 | R/W-0 | R/W-0 |
| PUH7 | PUH6 | PUH5 | PUH4 | PUH3 | PUH2 | PUH1 | PUH0 |
| bit 7 | | | | | | | bit 0 |

Legend:

R = Readable bit W = Writable bit U = Unimplemented bit, read as '0'
 -n = Value at POR '1' = Bit is set '0' = Bit is cleared x = Bit is unknown

bit 15-11 **Unimplemented:** Read as '0'
 bit 10-0 **PUH<10:0>:** GPU Work Area Height bits (in pixels)

PIC24FJ256DA210 FAMILY

[查询PIC24FJ256DA106供应商](#)

REGISTER 22-15: G1DPADRL: DISPLAY BUFFER START ADDRESS REGISTER LOW

| | | | | | | | |
|---------|---------|---------|---------|---------|---------|--------|--------|
| R/W-0 | R/W-0 | R/W-0 | R/W-0 | R/W-0 | R/W-0 | R/W-0 | R/W-0 |
| DPADR15 | DPADR14 | DPADR13 | DPADR12 | DPADR11 | DPADR10 | DPADR9 | DPADR8 |
| bit 15 | | | | | | | bit 8 |

| | | | | | | | |
|--------|--------|--------|--------|--------|--------|--------|--------|
| R/W-0 | R/W-0 | R/W-0 | R/W-0 | R/W-0 | R/W-0 | R/W-0 | R/W-0 |
| DPADR7 | DPADR6 | DPADR5 | DPADR4 | DPADR3 | DPADR2 | DPADR1 | DPADR0 |
| bit 7 | | | | | | | bit 0 |

Legend:

R = Readable bit W = Writable bit U = Unimplemented bit, read as '0'
 -n = Value at POR '1' = Bit is set '0' = Bit is cleared x = Bit is unknown

bit 15-0 **DPADR<15:0>**: Display Buffer Start Address Low bits
 Display buffer start address must point to an even byte address in memory.

REGISTER 22-16: G1DPADRH: DISPLAY BUFFER START ADDRESS REGISTER HIGH

| | | | | | | | |
|--------|-----|-----|-----|-----|-----|-----|-------|
| U-0 | U-0 | U-0 | U-0 | U-0 | U-0 | U-0 | U-0 |
| — | — | — | — | — | — | — | — |
| bit 15 | | | | | | | bit 8 |

| | | | | | | | |
|---------|---------|---------|---------|---------|---------|---------|---------|
| R/W-0 | R/W-0 | R/W-0 | R/W-0 | R/W-0 | R/W-0 | R/W-0 | R/W-0 |
| DPADR23 | DPADR22 | DPADR21 | DPADR20 | DPADR19 | DPADR18 | DPADR17 | DPADR16 |
| bit 7 | | | | | | | bit 0 |

Legend:

R = Readable bit W = Writable bit U = Unimplemented bit, read as '0'
 -n = Value at POR '1' = Bit is set '0' = Bit is cleared x = Bit is unknown

bit 15-8 **Unimplemented**: Read as '0'
 bit 7-0 **DPADR<23:16>**: Display Buffer Start Address High bits
 Display buffer start address must point to an even byte address in memory.

REGISTER 22-17: G1DPW: DISPLAY BUFFER WIDTH REGISTER

| | | | | | | | |
|--------|-----|-----|-----|-----|-------|-------|-------|
| U-0 | U-0 | U-0 | U-0 | U-0 | R/W-0 | R/W-0 | R/W-0 |
| — | — | — | — | — | DPW10 | DPW9 | DPW8 |
| bit 15 | | | | | | | bit 8 |

| | | | | | | | |
|-------|-------|-------|-------|-------|-------|-------|-------|
| R/W-0 | R/W-0 | R/W-0 | R/W-0 | R/W-0 | R/W-0 | R/W-0 | R/W-0 |
| DPW7 | DPW6 | DPW5 | DPW4 | DPW3 | DPW2 | DPW1 | DPW0 |
| bit 7 | | | | | | | bit 0 |

Legend:

R = Readable bit W = Writable bit U = Unimplemented bit, read as '0'
 -n = Value at POR '1' = Bit is set '0' = Bit is cleared x = Bit is unknown

bit 15-11 **Unimplemented**: Read as '0'
 bit 10-0 **DPW<10:0>**: Display Frame Width bits (in pixels)

PIC24FJ256DA210 FAMILY

[查询PIC24FJ256DA106供应商](#)

REGISTER 22-18: G1DPH: DISPLAY BUFFER HEIGHT REGISTER

| | | | | | | | |
|--------|-----|-----|-----|-----|-------|-------|-------|
| U-0 | U-0 | U-0 | U-0 | U-0 | R/W-0 | R/W-0 | R/W-0 |
| — | — | — | — | — | DPH10 | DPH9 | DPH8 |
| bit 15 | | | | | bit 8 | | |

| | | | | | | | |
|-------|-------|-------|-------|-------|-------|-------|-------|
| R/W-0 | R/W-0 | R/W-0 | R/W-0 | R/W-0 | R/W-0 | R/W-0 | R/W-0 |
| DPH7 | DPH6 | DPH5 | DPH4 | DPH3 | DPH2 | DPH1 | DPH0 |
| bit 7 | | | | | bit 0 | | |

Legend:

R = Readable bit W = Writable bit U = Unimplemented bit, read as '0'
 -n = Value at POR '1' = Bit is set '0' = Bit is cleared x = Bit is unknown

bit 15-11 **Unimplemented:** Read as '0'
 bit 10-0 **DPH<10:0>:** Display Frame Height bits (in pixels)

REGISTER 22-19: G1DPWT: DISPLAY TOTAL WIDTH REGISTER

| | | | | | | | |
|--------|-----|-----|-----|-----|--------|-------|-------|
| U-0 | U-0 | U-0 | U-0 | U-0 | R/W-0 | R/W-0 | R/W-0 |
| — | — | — | — | — | DPWT10 | DPWT9 | DPWT8 |
| bit 15 | | | | | bit 8 | | |

| | | | | | | | |
|-------|-------|-------|-------|-------|-------|-------|-------|
| R/W-0 | R/W-0 | R/W-0 | R/W-0 | R/W-0 | R/W-0 | R/W-0 | R/W-0 |
| DPWT7 | DPWT6 | DPWT5 | DPWT4 | DPWT3 | DPWT2 | DPWT1 | DPWT0 |
| bit 7 | | | | | bit 0 | | |

Legend:

R = Readable bit W = Writable bit U = Unimplemented bit, read as '0'
 -n = Value at POR '1' = Bit is set '0' = Bit is cleared x = Bit is unknown

bit 15-11 **Unimplemented:** Read as '0'
 bit 10-0 **DPWT<10:0>:** Display Total Width bits (in pixels)

REGISTER 22-20: G1DPHT: DISPLAY TOTAL HEIGHT REGISTER

| | | | | | | | |
|--------|-----|-----|-----|-----|--------|-------|-------|
| U-0 | U-0 | U-0 | U-0 | U-0 | R/W-0 | R/W-0 | R/W-0 |
| — | — | — | — | — | DPHT10 | DPHT9 | DPHT8 |
| bit 15 | | | | | bit 8 | | |

| | | | | | | | |
|-------|-------|-------|-------|-------|-------|-------|-------|
| R/W-0 | R/W-0 | R/W-0 | R/W-0 | R/W-0 | R/W-0 | R/W-0 | R/W-0 |
| DPHT7 | DPHT6 | DPHT5 | DPHT4 | DPHT3 | DPHT2 | DPHT1 | DPHT0 |
| bit 7 | | | | | bit 0 | | |

Legend:

R = Readable bit W = Writable bit U = Unimplemented bit, read as '0'
 -n = Value at POR '1' = Bit is set '0' = Bit is cleared x = Bit is unknown

bit 15-11 **Unimplemented:** Read as '0'
 bit 10-0 **DPHT<10:0>:** Display Total Height bits (in pixels)

PIC24FJ256DA210 FAMILY

[查询PIC24FJ256DA106供应商](#)

REGISTER 22-21: G1ACTDA: ACTIVE DISPLAY AREA REGISTER

| | | | | | | | |
|----------|----------|----------|----------|----------|----------|----------|----------|
| R/W-0 | R/W-0 | R/W-0 | R/W-0 | R/W-0 | R/W-0 | R/W-0 | R/W-0 |
| ACTLINE7 | ACTLINE6 | ACTLINE5 | ACTLINE4 | ACTLINE3 | ACTLINE2 | ACTLINE1 | ACTLINE0 |
| bit 15 | | | | | | | bit 8 |

| | | | | | | | |
|---------|---------|---------|---------|---------|---------|---------|---------|
| R/W-0 | R/W-0 | R/W-0 | R/W-0 | R/W-0 | R/W-0 | R/W-0 | R/W-0 |
| ACTPIX7 | ACTPIX6 | ACTPIX5 | ACTPIX4 | ACTPIX3 | ACTPIX2 | ACTPIX1 | ACTPIX0 |
| bit 7 | | | | | | | bit 0 |

Legend:

R = Readable bit W = Writable bit U = Unimplemented bit, read as '0'
 -n = Value at POR '1' = Bit is set '0' = Bit is cleared x = Bit is unknown

bit 15-8 **ACTLINE<7:0>**: Number of Lines Before the First Active (Displayed) Line bits
 Typically, ACTLINE_x = VENST_x (G1DBLCON<15:8>).
 This register is added for versatility in the timing of the active lines.
 For TFT mode, DPMODE bits (G1CON2<2:0>) = 001; the minimum value is 2.
 For STN mode, DPMODE bits (G1CON2<2:0>) = 010,011,100; the minimum value is 0.

bit 7-0 **ACTPIX<7:0>**: Number of Pixels Before the First Active (Displayed) Pixel bits (in DISPCLKs)
 Typically, ACTPIX_x = HENST_x (G1DBLCON<7:0>).
 This register is added for versatility in the timing of the active pixels. Note that the programmed value is computed in DISPCLK cycles. This value is dependent on the DPGWIDTH bit (G1CON2<15:14>). Refer to the "PIC24F Family Reference Manual", Section 43. "Graphics Controller Module (GFX)" for details.

REGISTER 22-22: G1HSYNC: HORIZONTAL SYNCHRONIZATION CONTROL REGISTER

| | | | | | | | |
|--------|-------|-------|-------|-------|-------|-------|-------|
| R/W-0 | R/W-0 | R/W-0 | R/W-0 | R/W-0 | R/W-0 | R/W-0 | R/W-0 |
| HLEN7 | HLEN6 | HLEN5 | HLEN4 | HLEN3 | HLEN2 | HLEN1 | HLEN0 |
| bit 15 | | | | | | | bit 8 |

| | | | | | | | |
|-------|-------|-------|-------|-------|-------|-------|-------|
| R/W-0 | R/W-0 | R/W-0 | R/W-0 | R/W-0 | R/W-0 | R/W-0 | R/W-0 |
| HSST7 | HSST6 | HSST5 | HSST4 | HSST3 | HSST2 | HSST1 | HSST0 |
| bit 7 | | | | | | | bit 0 |

Legend:

R = Readable bit W = Writable bit U = Unimplemented bit, read as '0'
 -n = Value at POR '1' = Bit is set '0' = Bit is cleared x = Bit is unknown

bit 15-8 **HLEN<7:0>**: HSYNC Pulse-Width Configuration bits (in DISPCLKs)
 DPHSOE bit (G1CON3<0>) must be set for the HSYNC signal to toggle; minimum value is 1.

bit 7-0 **HSST<7:0>**: HSYNC Start Delay Configuration bits (in DISPCLKs)
 This is the number of DISPCLK cycles from the start of horizontal blanking to the start of HSYNC active.

PIC24FJ256DA210 FAMILY

[查询PIC24FJ256DA106供应商](#)

REGISTER 22-23: G1VSYNC: VERTICAL SYNCHRONIZATION CONTROL REGISTER

| | | | | | | | |
|--------|--------|--------|--------|--------|--------|--------|--------|
| R/W-0 | R/W-0 | R/W-0 | R/W-0 | R/W-0 | R/W-0 | R/W-0 | R/W-0 |
| VSLEN7 | VSLEN6 | VSLEN5 | VSLEN4 | VSLEN3 | VSLEN2 | VSLEN1 | VSLEN0 |
| bit 15 | | | | | | | bit 8 |

| | | | | | | | |
|-------|-------|-------|-------|-------|-------|-------|-------|
| R/W-0 | R/W-0 | R/W-0 | R/W-0 | R/W-0 | R/W-0 | R/W-0 | R/W-0 |
| VSST7 | VSST6 | VSST5 | VSST4 | VSST3 | VSST2 | VSST1 | VSST0 |
| bit 7 | | | | | | | bit 0 |

Legend:

R = Readable bit W = Writable bit U = Unimplemented bit, read as '0'
 -n = Value at POR '1' = Bit is set '0' = Bit is cleared x = Bit is unknown

- bit 15-8 **VSLEN<7:0>**: VSYNC Pulse-Width Configuration bits (in lines)
 The DPVSOE bit (G1CON3<1>) must be set for the VSYNC signal to toggle; minimum value is 1.
- bit 7-0 **VSST<7:0>**: VSYNC Start Delay Configuration bits (in lines)
 This is the number of lines from the start of vertical blanking to the start of VSYNC active.

REGISTER 22-24: G1DBLCON: DISPLAY BLANKING CONTROL REGISTER

| | | | | | | | |
|--------|--------|--------|--------|--------|--------|--------|--------|
| R/W-0 | R/W-0 | R/W-0 | R/W-0 | R/W-0 | R/W-0 | R/W-0 | R/W-0 |
| VENST7 | VENST6 | VENST5 | VENST4 | VENST3 | VENST2 | VENST1 | VENST0 |
| bit 15 | | | | | | | bit 8 |

| | | | | | | | |
|--------|--------|--------|--------|--------|--------|--------|--------|
| R/W-0 | R/W-0 | R/W-0 | R/W-0 | R/W-0 | R/W-0 | R/W-0 | R/W-0 |
| HENST7 | HENST6 | HENST5 | HENST4 | HENST3 | HENST2 | HENST1 | HENST0 |
| bit 7 | | | | | | | bit 0 |

Legend:

R = Readable bit W = Writable bit U = Unimplemented bit, read as '0'
 -n = Value at POR '1' = Bit is set '0' = Bit is cleared x = Bit is unknown

- bit 15-8 **VENST<7:0>**: Vertical Blanking Start to First Displayed Line Configuration bits (in lines)
 This is the number of lines from the start of vertical blanking to the first displayed line of a frame.
- bit 7-0 **HENST<7:0>**: Horizontal Blanking Start to First Displayed Pixel Configuration bits (in DISPCLKs)
 This is the number of GCLK cycles from the start of horizontal blanking to the first displayed pixel of each displayed line.

PIC24FJ256DA210 FAMILY

[查询PIC24FJ256DA106供应商](#)

REGISTER 22-25: G1CLUT: COLOR LOOK-UP TABLE CONTROL REGISTER

| | | | | | | | |
|--------|----------|-----|-----|-----|-----|---------|----------|
| R/W-0 | R-0, HSC | U-0 | U-0 | U-0 | U-0 | R/W-0 | R/W-0 |
| CLUTEN | CLUTBUSY | — | — | — | — | CLUTTRD | CLUTRWEN |
| bit 15 | | | | | | bit 8 | |

| | | | | | | | |
|----------|----------|----------|----------|----------|----------|----------|----------|
| R/W-0 | R/W-0 | R/W-0 | R/W-0 | R/W-0 | R/W-0 | R/W-0 | R/W-0 |
| CLUTADR7 | CLUTADR6 | CLUTADR5 | CLUTADR4 | CLUTADR3 | CLUTADR2 | CLUTADR1 | CLUTADR0 |
| bit 7 | | | | | | bit 0 | |

| | |
|-------------------|---------------------------------------|
| Legend: | HSC = Hardware Settable/Clearable bit |
| R = Readable bit | W = Writable bit |
| -n = Value at POR | '1' = Bit is set |
| | '0' = Bit is cleared |
| | x = Bit is unknown |

- bit 15 **CLUTEN:** Color Look-up Table Enable Control bit
 1 = Color look-up table is enabled
 0 = Color look-up table is disabled
- bit 14 **CLUTBUSY:** Color Look-up Table Busy Status bit
 1 = A CLUT entry read/write access is being executed
 0 = No CLUT entry read/write access is being executed
- bit 13-10 **Unimplemented:** Read as '0'
- bit 9 **CLUTTRD:** Color Look-up Table Read Trigger bit
 Enabling this bit will trigger a read to the CLUT location determined by the CLUTADR bits (G1CLUT<7:0>) with CLUTRWEN enabled.
 1 = CLUT read trigger is enabled (must be cleared in software after reading data in the G1CLUTRD register)
 0 = CLUT read trigger is disabled
- bit 8 **CLUTRWEN:** Color Look-up Table Read/Write Enable Control bit
 This bit must be set when reading or modifying entries on the CLUT and it must also be cleared when CLUT is used by the display controller.
 1 = Color look-up table read/write enabled; display controller cannot access the CLUT
 0 = Color look-up table read/write disabled; display controller can access the CLUT
- bit 7-0 **CLUTADR<7:0>:** Color Look-up Table Memory Address bits

PIC24FJ256DA210 FAMILY

[查询PIC24FJ256DA106供应商](#)

REGISTER 22-26: G1CLUTWR: COLOR LOOK-UP TABLE (CLUT) MEMORY WRITE DATA REGISTER

| | | | | | | | |
|----------|----------|----------|----------|----------|----------|---------|---------|
| R/W-0 | R/W-0 | R/W-0 | R/W-0 | R/W-0 | R/W-0 | R/W-0 | R/W-0 |
| CLUTWR15 | CLUTWR14 | CLUTWR13 | CLUTWR12 | CLUTWR11 | CLUTWR10 | CLUTWR9 | CLUTWR8 |
| bit 15 | | | | | | | bit 8 |

| | | | | | | | |
|---------|---------|---------|---------|---------|---------|---------|---------|
| R/W-0 | R/W-0 | R/W-0 | R/W-0 | R/W-0 | R/W-0 | R/W-0 | R/W-0 |
| CLUTWR7 | CLUTWR6 | CLUTWR5 | CLUTWR4 | CLUTWR3 | CLUTWR2 | CLUTWR1 | CLUTWR0 |
| bit 7 | | | | | | | bit 0 |

Legend:

R = Readable bit W = Writable bit U = Unimplemented bit, read as '0'
 -n = Value at POR '1' = Bit is set '0' = Bit is cleared x = Bit is unknown

bit 15-0 **CLUTWR<15:0>**: Color Look-up Table Memory Write Data bits

A write to this register triggers a write to the CLUT memory at the address pointed to by the CLUTADR bits. A word write or a high byte write to this register triggers a write to the CLUT memory at the address pointed to by CLUTADR. Low byte write to this register will only update the G1CLUTWR<7:0> and no write to CLUT memory will be triggered. During power-up and power-down of the display, the most recent data written to this register will be used to control the timing of the GPWR signal. Refer to the "PIC24F Family Reference Manual", Section 43. "Graphics Controller Module (GFX)" for details on writing entries to the CLUT.

REGISTER 22-27: G1CLUTRD: COLOR LOOK-UP TABLE (CLUT) MEMORY READ DATA REGISTER

| | | | | | | | |
|----------|----------|----------|----------|----------|----------|----------|----------|
| R-0, HSC | R-0, HSC | R-0, HSC | R-0, HSC | R-0, HSC | R-0, HSC | R-0, HSC | R-0, HSC |
| CLUTRD15 | CLUTRD14 | CLUTRD13 | CLUTRD12 | CLUTRD11 | CLUTRD10 | CLUTRD9 | CLUTRD8 |
| bit 15 | | | | | | | bit 8 |

| | | | | | | | |
|----------|----------|----------|----------|----------|----------|----------|----------|
| R-0, HSC | R-0, HSC | R-0, HSC | R-0, HSC | R-0, HSC | R-0, HSC | R-0, HSC | R-0, HSC |
| CLUTRD7 | CLUTRD6 | CLUTRD5 | CLUTRD4 | CLUTRD3 | CLUTRD2 | CLUTRD1 | CLUTRD0 |
| bit 7 | | | | | | | bit 0 |

Legend:

HSC = Hardware Settable/Clearable bit
 R = Readable bit W = Writable bit U = Unimplemented bit, read as '0'
 -n = Value at POR '1' = Bit is set '0' = Bit is cleared x = Bit is unknown

bit 15-0 **CLUTRD<15:0>**: Color Look-up Table Memory Read Data bits

This register contains the most recent read from the CLUT memory pointed to by the CLUTADR bits (G1CLUT<7:0>). Reading of the CLUT memory is triggered when the CLUTTRD bit (G1CLUT<9>) goes from '0' to '1'. Refer to the "PIC24F Family Reference Manual", Section 43. "Graphics Controller Module (GFX)" for details on reading entries from the CLUT.

PIC24FJ256DA210 FAMILY

[查询PIC24FJ256DA106供应商](#)

REGISTER 22-28: G1MRGN: INTERRUPT ADVANCE REGISTER

| | | | | | | | |
|---------|---------|---------|---------|---------|---------|---------|---------|
| R/W-0 | R/W-0 | R/W-0 | R/W-0 | R/W-0 | R/W-0 | R/W-0 | R/W-0 |
| VBAMGN7 | VBAMGN6 | VBAMGN5 | VBAMGN4 | VBAMGN3 | VBAMGN2 | VBAMGN1 | VBAMGN0 |
| bit 15 | | | | | | | bit 8 |

| | | | | | | | |
|---------|---------|---------|---------|---------|---------|---------|---------|
| R/W-0 | R/W-0 | R/W-0 | R/W-0 | R/W-0 | R/W-0 | R/W-0 | R/W-0 |
| HBAMGN7 | HBAMGN6 | HBAMGN5 | HBAMGN4 | HBAMGN3 | HBAMGN2 | HBAMGN1 | HBAMGN0 |
| bit 7 | | | | | | | bit 0 |

Legend:

| | | |
|-------------------|------------------|--|
| R = Readable bit | W = Writable bit | U = Unimplemented bit, read as '0' |
| -n = Value at POR | '1' = Bit is set | '0' = Bit is cleared x = Bit is unknown |

bit 15-8 **VBAMGN<7:0>**: Vertical Blanking Advance bits

The number of DISPCLK cycles in advance that the vertical blanking interrupt will assert ahead of the actual start of the vertical blanking.

bit 7-0 **HBAMGN<7:0>**: Horizontal Blanking Advance bits

The number of DISPCLK cycles in advance that the horizontal blanking interrupt will assert ahead of the actual start of the horizontal blanking.

REGISTER 22-29: G1CHRX: CHARACTER-X COORDINATE PRINT POSITION REGISTER

| | | | | | | | |
|--------|-----|-----|-----|-----|-----------|----------|----------|
| U-0 | U-0 | U-0 | U-0 | U-0 | R-0, HSC | R-0, HSC | R-0, HSC |
| — | — | — | — | — | CURPOSX10 | CURPOSX9 | CURPOSX8 |
| bit 15 | | | | | | | bit 8 |

| | | | | | | | |
|----------|----------|----------|----------|----------|----------|----------|----------|
| R-0, HSC | R-0, HSC | R-0, HSC | R-0, HSC | R-0, HSC | R-0, HSC | R-0, HSC | R-0, HSC |
| CURPOSX7 | CURPOSX6 | CURPOSX5 | CURPOSX4 | CURPOSX3 | CURPOSX2 | CURPOSX1 | CURPOSX0 |
| bit 7 | | | | | | | bit 0 |

Legend:

| | |
|-------------------|--|
| | HSC = Hardware Settable/Clearable bit |
| R = Readable bit | W = Writable bit U = Unimplemented bit, read as '0' |
| -n = Value at POR | '1' = Bit is set '0' = Bit is cleared x = Bit is unknown |

bit 15-11 **Unimplemented**: Read as '0'

bit 10-0 **CURPOSX<10:0>**: Current Character Position in the X-Coordinate bits

PIC24FJ256DA210 FAMILY

查询PIC24FJ256DA106供应商

REGISTER 22-30: G1CHRY: CHARACTER Y-COORDINATE PRINT POSITION REGISTER

| | | | | | | | |
|--------|-----|-----|-----|-----|-----------|----------|----------|
| U-0 | U-0 | U-0 | U-0 | U-0 | R-0, HSC | R-0, HSC | R-0, HSC |
| — | — | — | — | — | CURPOSY10 | CURPOSY9 | CURPOSY8 |
| bit 15 | | | | | bit 8 | | |

| | | | | | | | |
|----------|----------|----------|----------|----------|----------|----------|----------|
| R-0, HSC | R-0, HSC | R-0, HSC | R-0, HSC | R-0, HSC | R-0, HSC | R-0, HSC | R-0, HSC |
| CURPOSY7 | CURPOSY6 | CURPOSY5 | CURPOSY4 | CURPOSY3 | CURPOSY2 | CURPOSY1 | CURPOSY0 |
| bit 7 | | | | | | | bit 0 |

| | | | |
|-------------------|---------------------------------------|------------------------------------|--------------------|
| Legend: | HSC = Hardware Settable/Clearable bit | | |
| R = Readable bit | W = Writable bit | U = Unimplemented bit, read as '0' | |
| -n = Value at POR | '1' = Bit is set | '0' = Bit is cleared | x = Bit is unknown |

bit 15-11 **Unimplemented:** Read as '0'

bit 10-0 **CURPOSY<10:0>:** Current Character Position in the Y-Coordinate bits

REGISTER 22-31: G1IPU: INFLATE PROCESSOR STATUS REGISTER

| | | | | | | | |
|--------|-----|-----|-----|-----|-----|-----|-------|
| U-0 | U-0 | U-0 | U-0 | U-0 | U-0 | U-0 | U-0 |
| — | — | — | — | — | — | — | — |
| bit 15 | | | | | | | bit 8 |

| | | | | | | | |
|-------|-----|------------------------|------------------------|-----------------------|------------------------|--------------------------|-------------------------|
| U-0 | U-0 | R-0, HSC | R-0, HSC | R-0, HSC | R-0, HSC | R-0, HSC | R-0, HSC |
| — | — | HUFFERR ⁽²⁾ | BLCKERR ⁽²⁾ | LENERR ⁽²⁾ | WRAPERR ⁽²⁾ | IPUDONE ^(1,2) | BFINAL ^(1,2) |
| bit 7 | | | | | | | bit 0 |

| | | | |
|-------------------|---------------------------------------|------------------------------------|--------------------|
| Legend: | HSC = Hardware Settable/Clearable bit | | |
| R = Readable bit | W = Writable bit | U = Unimplemented bit, read as '0' | |
| -n = Value at POR | '1' = Bit is set | '0' = Bit is cleared | x = Bit is unknown |

bit 15-6 **Unimplemented:** Read as '0'

bit 5 **HUFFERR:** Undefined Huffman Code Encountered Status bit⁽²⁾

1 = Undefined code is encountered
0 = No undefined code is encountered

bit 4 **BLCKERR:** Undefined Block Code Encountered Status bit⁽²⁾

1 = Undefined block is encountered
0 = No undefined block is encountered

bit 3 **LENERR:** Mismatch in Expected Block Length Status bit⁽²⁾

1 = Mismatch in block length is detected
0 = No mismatch in block length is detected

bit 2 **WRAPERR:** Wrap-Around Error Status bit⁽²⁾

1 = Wrap-around error is encountered
0 = No wrap-around error is encountered

bit 1 **IPUDONE:** IPU Decompression Status bit^(1,2)

1 = Decompression is done
0 = Decompression is not yet done

bit 0 **BFINAL:** Final Block Encountered Status bit^(1,2)

1 = Final block is encountered
0 = Final block is not encountered

Note 1: IPUDONE and BFINAL status bits are set after successful decompression.

Note 2: All IPU status bits are available after each decompression. All status bits are automatically cleared every time a decompression command (IPU_DECOMPRESS) is issued.

PIC24FJ256DA210 FAMILY

[查询PIC24FJ256DA106供应商](#)

REGISTER 22-32: GDBEN: DATA I/O PAD ENABLE REGISTER

| | | | | | | | |
|---------|---------|---------|---------|---------|---------|--------|--------|
| R/W-0 | R/W-0 | R/W-0 | R/W-0 | R/W-0 | R/W-0 | R/W-0 | R/W-0 |
| GDBEN15 | GDBEN14 | GDBEN13 | GDBEN12 | GDBEN11 | GDBEN10 | GDBEN9 | GDBEN8 |
| bit 15 | | | | | | | bit 8 |

| | | | | | | | |
|--------|--------|--------|--------|--------|--------|--------|--------|
| R/W-0 | R/W-0 | R/W-0 | R/W-0 | R/W-0 | R/W-0 | R/W-0 | R/W-0 |
| GDBEN7 | GDBEN6 | GDBEN5 | GDBEN4 | GDBEN3 | GDBEN2 | GDBEN1 | GDBEN0 |
| bit 7 | | | | | | | bit 0 |

Legend:

R = Readable bit

W = Writable bit

U = Unimplemented bit, read as '0'

-n = Value at POR

'1' = Bit is set

'0' = Bit is cleared

x = Bit is unknown

bit 15-0

GDBEN<15:0>: Display Data Pads Output Enable bits

1 = Corresponding display data (GD<x>) pin is enabled

0 = Corresponding display data (GD<x>) pin is disabled

GDBEN<15:0> can be used to disable or enable specific data signals while the DPPINOE bit (G1CON3<9>) is set.

| DPPINOE | GDBENx (where x = 0 to 15) | |
|---------|-------------------------------|--|
| 1 | 1 | Display data signal (GD) associated with GDBENx is enabled. |
| 1 | 0 | Display data signal (GD) associated with GDBENx is disabled. |
| 0 | x | Display data signal (GD) associated with GDBENx is disabled. |

PIC24FJ256DA210 FAMILY

[查询PIC24FJ256DA106供应商](#)

22.2 Display Resolution and Memory Requirements

The PIC24FJ256DA210 family of devices has two variants in terms of on-board RAM (24-Kbyte and 96-Kbyte variants). The 24-Kbyte variant supports monochrome displays while the 96-Kbyte variant supports Quarter VGA (QVGA) color displays, up to 256 colors. Support of higher resolution displays with higher color depth requirements are available by extending the data space through external memory. Table 22-1 provides the summary of image buffer memory requirements of different display resolutions and color depth requirements.

22.3 Display Clock (GCLK) Source

Frequency of the Graphics Controller Display Clock (GCLK) signal is determined by programming the GCLKDIV bits (CLKDIV2<15:9>). For more information, refer to the “PIC24F Family Reference Manual”, Section 6. “Oscillator” (DS39700).



22.4 Display Buffer and Work Areas Memory Locations

The PIC24FJ256DA210 family of devices has variants with two on-board RAM sizes. These are the 24-Kbyte and 96-Kbyte variants. These two RAM variants are further divided in terms of pin counts. The 100-pin count device will have the EPMP module available for extending RAM for applications. The 64-pin count device will not have the EPMP modules. Extending the RAM size is necessary for applications that require larger display buffers and work areas. It is recommended that the display buffers and work areas are **not** mapped into an area that overlaps the internal RAM and the external RAM. The external RAM can be interfaced using the EPMP module. For details, refer to the “PIC24F Family Reference Manual”, Section 42. “Enhanced Parallel Master Port (EPMP)” (DS39730).

TABLE 22-1: BUFFER MEMORY REQUIREMENTS vs. DISPLAY CONFIGURATION

| Display Resolution | Display Buffer Memory Requirements (Bytes) | | | | |
|--------------------|--|-------|-------|--------|--------|
| | 1 Bpp | 2 Bpp | 4 Bpp | 8 Bpp | 16 Bpp |
| 480x272 (WQVGA) | 16320 | 32640 | 65280 | 130560 | 261120 |
| 320x240 (QVGA) | 9600 | 19200 | 38400 | 76800 | 153600 |
| 240x160 (HQVGA) | 4800 | 9600 | 19200 | 38400 | 76800 |
| 160x160 | 3200 | 6400 | 12800 | 25600 | 51200 |
| 160x120 (QQVGA) | 2400 | 4800 | 9600 | 19200 | 38400 |
| 128x64 | 1024 | 2048 | 4096 | 8192 | 16384 |

Legend:

-  Less than 24-Kbyte RAM variants (PIC24FJXXXDA106)
-  Less than 96-Kbyte RAM variants (PIC24FJXXXDA2XX)
-  External Memory with 96 Kbytes/24 Kbytes of RAM variants (PIC24FJXXXDAX10)

PIC24FJ256DA210 FAMILY

[查询PIC24FJ256DA106供应商](#)

23.0 10-BIT HIGH-SPEED A/D CONVERTER

Note: This data sheet summarizes the features of this group of PIC24F devices. It is not intended to be a comprehensive reference source. For more information, refer to the “PIC24F Family Reference Manual”, **Section 17. “10-Bit A/D Converter”** (DS39705). The information in this data sheet supersedes the information in the FRM.

The 10-bit A/D Converter has the following key features:

- Successive Approximation (SAR) conversion
- Conversion speeds of up to 500 ksp/s
- 24 analog input pins (PIC24FJXXXDAX10 devices) and 16 analog input pins (PIC24FJXXXDAX06 devices)
- External voltage reference input pins
- Internal band gap reference inputs
- Automatic Channel Scan mode
- Selectable conversion trigger source
- 32-word conversion result buffer
- Selectable Buffer Fill modes
- Four result alignment options
- Operation during CPU Sleep and Idle modes

On all PIC24FJ256DA210 family devices, the 10-bit A/D Converter has 24 analog input pins, designated AN0 through AN23. In addition, there are two analog input pins for external voltage reference connections (VREF+ and VREF-). These voltage reference inputs may be shared with other analog input pins.

A block diagram of the A/D Converter is shown in Figure 23-1.

To perform an A/D conversion:

1. Configure the A/D module:
 - a) Configure the port pins as analog inputs and/or select band gap reference inputs (ANCFG registers).
 - b) Select the voltage reference source to match the expected range on analog inputs (AD1CON2<15:13>).
 - c) Select the analog conversion clock to match the desired data rate with the processor clock (AD1CON3<7:0>).
 - d) Select the appropriate sample/conversion sequence (AD1CON1<7:5> and AD1CON3<12:8>).
 - e) Select how the conversion results are presented in the buffer (AD1CON1<9:8>).
 - f) Select the interrupt rate (AD1CON2<6:2>).
 - g) Turn on the A/D module (AD1CON1<15>).
2. Configure the A/D interrupt (if required):
 - a) Clear the AD1IF bit.
 - b) Select the A/D interrupt priority.

PIC24FJ256DA210 FAMILY

[查询PIC24FJ256DA106供应商](#)

FIGURE 23-1: 10-BIT HIGH-SPEED A/D CONVERTER BLOCK DIAGRAM

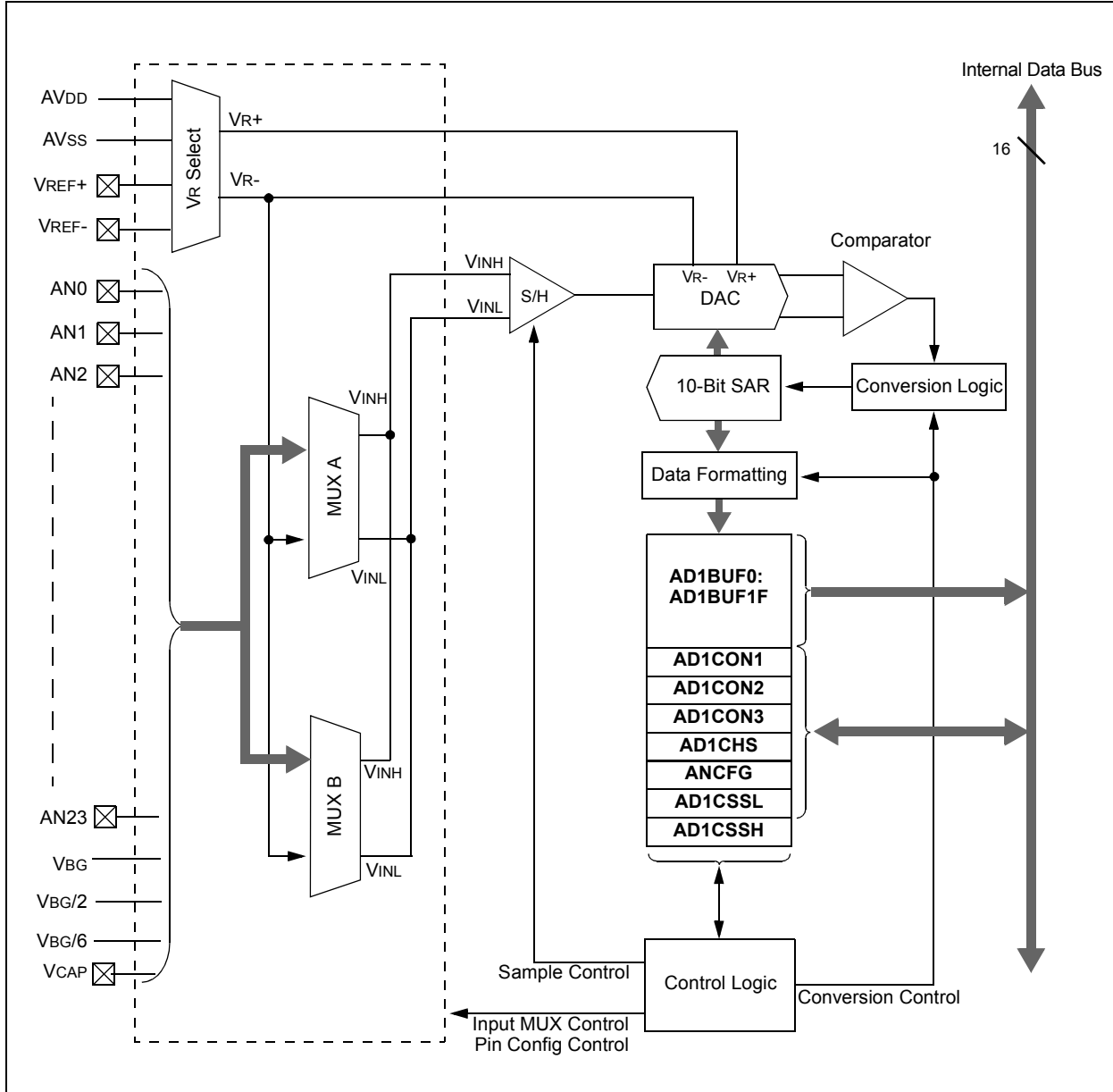

PIC24FJ256DA210 FAMILY

[查询PIC24FJ256DA106供应商](#)

REGISTER 23-1: AD1CON1: A/D CONTROL REGISTER 1

| | | | | | | | |
|---------------------|-----|--------|-----|-----|-----|-------|-------|
| R/W-0 | U-0 | R/W-0 | U-0 | U-0 | U-0 | R/W-0 | R/W-0 |
| ADON ⁽¹⁾ | — | ADSIDL | — | — | — | FORM1 | FORM0 |
| bit 15 | | | | | | bit 8 | |

| | | | | | | | |
|-------|-------|-------|-----|-----|-------|----------|----------|
| R/W-0 | R/W-0 | R/W-0 | U-0 | U-0 | R/W-0 | R-0, HSC | R-0, HSC |
| SSRC2 | SSRC1 | SSRC0 | — | — | ASAM | SAMP | DONE |
| bit 7 | | | | | | bit 0 | |

| | | | |
|-------------------|---------------------------------------|------------------------------------|--------------------|
| Legend: | HSC = Hardware Settable/Clearable bit | | |
| R = Readable bit | W = Writable bit | U = Unimplemented bit, read as '0' | |
| -n = Value at POR | '1' = Bit is set | '0' = Bit is cleared | x = Bit is unknown |

- bit 15 **ADON:** A/D Operating Mode bit⁽¹⁾
 1 = A/D Converter module is operating
 0 = A/D Converter is off
- bit 14 **Unimplemented:** Read as '0'
- bit 13 **ADSIDL:** Stop in Idle Mode bit
 1 = Discontinue module operation when device enters Idle mode
 0 = Continue module operation in Idle mode
- bit 12-10 **Unimplemented:** Read as '0'
- bit 9-8 **FORM<1:0>:** Data Output Format bits
 11 = Signed fractional (sddd dddd dd00 0000)
 10 = Fractional (dddd dddd dd00 0000)
 01 = Signed integer (ssss sssd dddd dddd)
 00 = Integer (0000 00dd dddd dddd)
- bit 7-5 **SSRC<2:0>:** Conversion Trigger Source Select bits
 111 = Internal counter ends sampling and starts conversion (auto-convert)
 110 = CTMU event ends sampling and starts conversion
 101 = Reserved
 100 = Timer5 compare ends sampling and starts conversion
 011 = Reserved
 010 = Timer3 compare ends sampling and starts conversion
 001 = Active transition on INT0 pin ends sampling and starts conversion
 000 = Clearing SAMP bit ends sampling and starts conversion
- bit 4-3 **Unimplemented:** Read as '0'
- bit 2 **ASAM:** A/D Sample Auto-Start bit
 1 = Sampling begins immediately after the last conversion completes. The SAMP bit is auto-set.
 0 = Sampling begins when the SAMP bit is set
- bit 1 **SAMP:** A/D Sample Enable bit
 1 = A/D sample/hold amplifier is sampling input
 0 = A/D sample/hold amplifier is holding
- bit 0 **DONE:** A/D Conversion Status bit
 1 = A/D conversion is done
 0 = A/D conversion is NOT done

Note 1: The values of the ADC1BUFx registers will not retain their values once the ADON bit is cleared. Read out the conversion values from the buffer before disabling the module.

PIC24FJ256DA210 FAMILY

查询PIC24FJ256DA106供应商

REGISTER 23-2: AD1CON2: A/D CONTROL REGISTER 2

| | | | | | | | |
|--------|-------|-------|-----|-----|-------|-----|-------|
| R/W-0 | R/W-0 | R/W-0 | r-0 | U-0 | R/W-0 | U-0 | U-0 |
| VCFG2 | VCFG1 | VCFG0 | r | — | CSCNA | — | — |
| bit 15 | | | | | | | bit 8 |

| | | | | | | | |
|----------|-------|-------|-------|-------|-------|-------|-------|
| R-0, HSC | R/W-0 | R/W-0 | R/W-0 | R/W-0 | R/W-0 | R/W-0 | R/W-0 |
| BUFS | SMPI4 | SMPI3 | SMPI2 | SMPI1 | SMPI0 | BUFM | ALTS |
| bit 7 | | | | | | | bit 0 |

| | | |
|-------------------|------------------|--|
| Legend: | r = Reserved bit | HSC = Hardware Settable/Clearable bit |
| R = Readable bit | W = Writable bit | U = Unimplemented bit, read as '0' |
| -n = Value at POR | '1' = Bit is set | '0' = Bit is cleared x = Bit is unknown |

bit 15-13 **VCFG<2:0>**: Voltage Reference Configuration bits

| VCFG<2:0> | Vr+ | Vr- |
|-----------|--------------------|--------------------|
| 000 | AVDD | AVSS |
| 001 | External VREF+ pin | AVSS |
| 010 | AVDD | External VREF- pin |
| 011 | External VREF+ pin | External VREF- pin |
| 1xx | AVDD | AVSS |

bit 12 **Reserved:** Maintain as '0'

bit 11 **Unimplemented:** Read as '0'

bit 10 **CSCNA:** Scan Input Selections for the CH0+ S/H Input for MUX A Input Multiplexer Setting bit

- 1 = Scan inputs
- 0 = Do not scan inputs

bit 9-8 **Unimplemented:** Read as '0'

bit 7 **BUFS:** Buffer Fill Status bit (valid only when BUFM = 1)

- 1 = A/D is currently filling buffer, 10-1F, user should access data in 00-0F
- 0 = A/D is currently filling buffer, 00-0F, user should access data in 10-1F

bit 6-2 **SMPI<4:0>**: Sample/Convert Sequences Per Interrupt Selection bits

- 11111 = Interrupts at the completion of conversion for each 32nd sample/convert sequence
- 11110 = Interrupts at the completion of conversion for each 31st sample/convert sequence
- .
- .
- 00001 = Interrupts at the completion of conversion for each 2nd sample/convert sequence
- 00000 = Interrupts at the completion of conversion for each sample/convert sequence

bit 1 **BUFM:** Buffer Mode Select bit

- 1 = Buffer is configured as two 16-word buffers (ADC1BUFn<31:16> and ADC1BUFn<15:0>)
- 0 = Buffer is configured as one 32-word buffer (ADC1BUFn<31:0>)

bit 0 **ALTS:** Alternate Input Sample Mode Select bit

- 1 = Uses MUX A input multiplexer settings for the first sample, then alternates between MUX B and MUX A input multiplexer settings for all subsequent samples
- 0 = Always uses the MUX A input multiplexer settings

PIC24FJ256DA210 FAMILY

[查询PIC24FJ256DA106供应商](#)

REGISTER 23-3: AD1CON3: A/D CONTROL REGISTER 3

| | | | | | | | |
|--------|-----|-----|-------|-------|-------|-------|-------|
| R/W-0 | r-0 | r-0 | R/W-0 | R/W-0 | R/W-0 | R/W-0 | R/W-0 |
| ADRC | r | r | SAMC4 | SAMC3 | SAMC2 | SAMC1 | SAMC0 |
| bit 15 | | | | | | | bit 8 |

| | | | | | | | |
|-------|-------|-------|-------|-------|-------|-------|-------|
| R/W-0 | R/W-0 | R/W-0 | R/W-0 | R/W-0 | R/W-0 | R/W-0 | R/W-0 |
| ADCS7 | ADCS6 | ADCS5 | ADCS4 | ADCS3 | ADCS2 | ADCS1 | ADCS0 |
| bit 7 | | | | | | | bit 0 |

| | | |
|-------------------|----------------------|------------------------------------|
| Legend: | r = Reserved bit | U = Unimplemented bit, read as '0' |
| R = Readable bit | W = Writable bit | '1' = Bit is set |
| -n = Value at POR | '0' = Bit is cleared | x = Bit is unknown |

bit 15 **ADRC:** A/D Conversion Clock Source bit
 1 = A/D internal RC clock
 0 = Clock is derived from the system clock

bit 14-13 **Reserved:** Maintain as '0'

bit 12-8 **SAMC<4:0>:** Auto-Sample Time bits
 11111 = 31 TAD
 .
 .
 .
 00001 = 1 TAD
 00000 = 0 TAD (not recommended)

bit 7-0 **ADCS<7:0>:** A/D Conversion Clock Select bits
 11111111 = 256 * Tcy

 00000001 = 2 * Tcy
 00000000 = Tcy

PIC24FJ256DA210 FAMILY

查询PIC24FJ256DA106供应商

REGISTER 23-4: AD1CHS: A/D INPUT SELECT REGISTER

| | | | | | | | | |
|--------|-----|-----|-----------------------|-----------------------|-----------------------|-----------------------|-----------------------|-------|
| R/W-0 | U-0 | U-0 | R/W-0 | R/W-0 | R/W-0 | R/W-0 | R/W-0 | |
| CH0NB | — | — | CH0SB4 ⁽¹⁾ | CH0SB3 ⁽¹⁾ | CH0SB2 ⁽¹⁾ | CH0SB1 ⁽¹⁾ | CH0SB0 ⁽¹⁾ | |
| bit 15 | | | | | | | | bit 8 |

| | | | | | | | | |
|-------|-----|-----|-----------------------|-----------------------|-----------------------|-----------------------|-----------------------|-------|
| R/W-0 | U-0 | U-0 | R/W-0 | R/W-0 | R/W-0 | R/W-0 | R/W-0 | |
| CH0NA | — | — | CH0SA4 ⁽¹⁾ | CH0SA3 ⁽¹⁾ | CH0SA2 ⁽¹⁾ | CH0SA1 ⁽¹⁾ | CH0SA0 ⁽¹⁾ | |
| bit 7 | | | | | | | | bit 0 |

Legend:

R = Readable bit

W = Writable bit

U = Unimplemented bit, read as '0'

-n = Value at POR

'1' = Bit is set

'0' = Bit is cleared

x = Bit is unknown

bit 15 **CH0NB:** Channel 0 Negative Input Select for MUX B Multiplexer Setting bit

1 = Channel 0 negative input is AN1

0 = Channel 0 negative input is VR-

bit 14-13 **Unimplemented:** Read as '0'

bit 12-8 **CH0SB<4:0>:** Channel 0 Positive Input Select for MUX B⁽¹⁾

Other = Not available; do not use

11111 = No channel used; all inputs are floating; used for CTMU

11011 = Channel 0 positive input is the band gap divided-by-six reference (VBG/6)

11010 = Channel 0 positive input is the core voltage (VCAP)

11001 = Channel 0 positive input is the band gap reference (VBG)

11000 = Channel 0 positive input is the band gap divided-by-two reference (VBG/2)

10111 = Channel 0 positive input is AN23⁽²⁾

.

.

.

00001 = Channel 0 positive input is AN1

00000 = Channel 0 positive input is AN0

bit 7 **CH0NA:** Channel 0 Negative Input Select for MUX A Multiplexer Setting bit

1 = Channel 0 negative input is AN1

0 = Channel 0 negative input is VR-

bit 6-5 **Unimplemented:** Read as '0'

bit 4-0 **CH0SA<4:0>:** Channel 0 Positive Input Select for MUX⁽¹⁾

Other = Not available; do not use

11111 = No Channel used; all inputs are floating; used for CTMU

11011 = Channel 0 positive input is the band gap divided-by-six reference (VBG/6)

11010 = Channel 0 positive input is the core voltage (VCAP)

11001 = Channel 0 positive input is the band gap reference (VBG)

11000 = Channel 0 positive input is the band gap divided-by-two reference (VBG/2)

10111 = Channel 0 positive input is AN23⁽²⁾

.

.

.

00001 = Channel 0 positive input is AN1

00000 = Channel 0 positive input is AN0

Note 1: Combinations not shown here (11100 to 11110) are unimplemented; do not use.

Note 2: Channel 0 positive inputs, AN16 through AN23, are not available on 64-pin devices (PIC24FJXXXDAX06).

PIC24FJ256DA210 FAMILY

[查询PIC24FJ256DA106供应商](#)

REGISTER 23-5: ANCFG: A/D BAND GAP REFERENCE CONFIGURATION REGISTER

| | | | | | | | |
|--------|-----|-----|-----|-----|-----|-----|-------|
| U-0 | U-0 | U-0 | U-0 | U-0 | U-0 | U-0 | U-0 |
| — | — | — | — | — | — | — | — |
| bit 15 | | | | | | | bit 8 |

| | | | | | | | |
|-------|-----|-----|-----|-----|--------|--------|-------|
| U-0 | U-0 | U-0 | U-0 | U-0 | R/W-0 | R/W-0 | R/W-0 |
| — | — | — | — | — | VBG6EN | VBG2EN | VBGEN |
| bit 7 | | | | | | | bit 0 |

Legend:

R = Readable bit W = Writable bit U = Unimplemented bit, read as '0'
 -n = Value at POR '1' = Bit is set '0' = Bit is cleared x = Bit is unknown

bit 15-3 **Unimplemented:** Read as '0'

bit 2 **VBG6EN:** A/D Input VBG/6 Enable bit

1 = Band gap voltage divided-by-six reference (VBG/6) is enabled
 0 = Band gap divided-by-six reference (VBG/6) is disabled

bit 1 **VBG2EN:** A/D Input VBG/2 Enable bit

1 = Band gap voltage divided-by-two reference (VBG/2) is enabled
 0 = Band gap divided-by-two reference (VBG/2) is disabled

bit 0 **VBGEN:** A/D Input VBG Enable bit

1 = Band gap voltage reference (VBG) is enabled
 0 = Band gap reference (VBG) is disabled

REGISTER 23-6: AD1CSSL: A/D INPUT SCAN SELECT REGISTER (LOW)

| | | | | | | | |
|--------|--------|--------|--------|--------|--------|-------|-------|
| R/W-0 | R/W-0 | R/W-0 | R/W-0 | R/W-0 | R/W-0 | R/W-0 | R/W-0 |
| CSSL15 | CSSL14 | CSSL13 | CSSL12 | CSSL11 | CSSL10 | CSSL9 | CSSL8 |
| bit 15 | | | | | | | bit 8 |

| | | | | | | | |
|-------|-------|-------|-------|-------|-------|-------|-------|
| R/W-0 | R/W-0 | R/W-0 | R/W-0 | R/W-0 | R/W-0 | R/W-0 | R/W-0 |
| CSSL7 | CSSL6 | CSSL5 | CSSL4 | CSSL3 | CSSL2 | CSSL1 | CSSL0 |
| bit 7 | | | | | | | bit 0 |

Legend:

R = Readable bit W = Writable bit U = Unimplemented bit, read as '0'
 -n = Value at POR '1' = Bit is set '0' = Bit is cleared x = Bit is unknown

bit 15-0 **CSSL<15:0>:** A/D Input Pin Scan Selection bits

1 = Corresponding analog channel is selected for input scan
 0 = Analog channel is omitted from input scan

PIC24FJ256DA210 FAMILY

[查询PIC24FJ256DA106供应商](#)

REGISTER 23-7: AD1CSSH: A/D INPUT SCAN SELECT REGISTER (HIGH)

| | | | | | | | |
|--------|-----|-----|-----|--------|--------|--------|--------|
| U-0 | U-0 | U-0 | U-0 | R/W-0 | R/W-0 | R/W-0 | R/W-0 |
| — | — | — | — | CSSL27 | CSSL26 | CSSL25 | CSSL24 |
| bit 15 | | | | | | | bit 8 |

| | | | | | | | |
|-----------------------|-----------------------|-----------------------|-----------------------|-----------------------|-----------------------|-----------------------|-----------------------|
| R/W-0 | R/W-0 | R/W-0 | R/W-0 | R/W-0 | R/W-0 | R/W-0 | R/W-0 |
| CSSL23 ⁽¹⁾ | CSSL22 ⁽¹⁾ | CSSL21 ⁽¹⁾ | CSSL20 ⁽¹⁾ | CSSL19 ⁽¹⁾ | CSSL18 ⁽¹⁾ | CSSL17 ⁽¹⁾ | CSSL16 ⁽¹⁾ |
| bit 7 | | | | | | | bit 0 |

Legend:

R = Readable bit

W = Writable bit

U = Unimplemented bit, read as '0'

-n = Value at POR

'1' = Bit is set

'0' = Bit is cleared

x = Bit is unknown

bit 15-12 **Unimplemented:** Read as '0'

bit 11 **CSSL27:** A/D Input Band Gap Scan Selection bit

1 = Band gap divided-by-six reference (VBG/6) is selected for input scan

0 = Analog channel is omitted from input scan

bit 10 **CSSL26:** A/D Input Band Gap Scan Selection bit

1 = Internal core voltage (VCAP) is selected for input scan

0 = Analog channel is omitted from input scan

bit 9 **CSSL25:** A/D Input Half Band Gap Scan Selection bit

1 = Band gap reference (VBG) is selected for input scan

0 = Analog channel is omitted from input scan

bit 8 **CSSL24:** A/D Input Band Gap Scan Selection bit

1 = Band gap divided-by-two reference (VBG/2) is selected for input scan

0 = Analog channel is omitted from input scan

bit 7-0 **CSSL<23:16>:** Analog Input Pin Scan Selection bits⁽¹⁾

1 = Corresponding analog channel selected for input scan

0 = Analog channel is omitted from input scan

Note 1: Unimplemented in 64-pin devices, read as '0'.

EQUATION 23-1: A/D CONVERSION CLOCK PERIOD⁽¹⁾

$$ADCS = \frac{T_{AD}}{T_{CY}} - 1$$

$$T_{AD} = T_{CY} \cdot (ADCS + 1)$$

Note 1: Based on $T_{CY} = 2 \cdot T_{OSC}$; Doze mode and PLL are disabled.

PIC24FJ256DA210 FAMILY

查询PIC24FJ256DA106供应商

FIGURE 23-2: 10-BIT A/D CONVERTER ANALOG INPUT MODEL

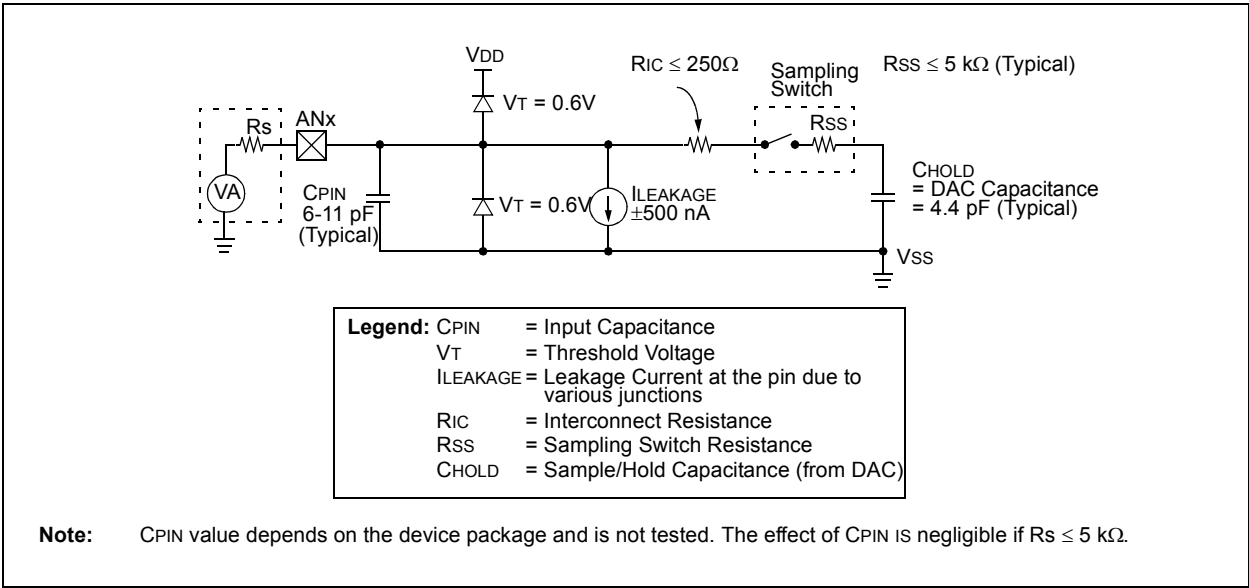
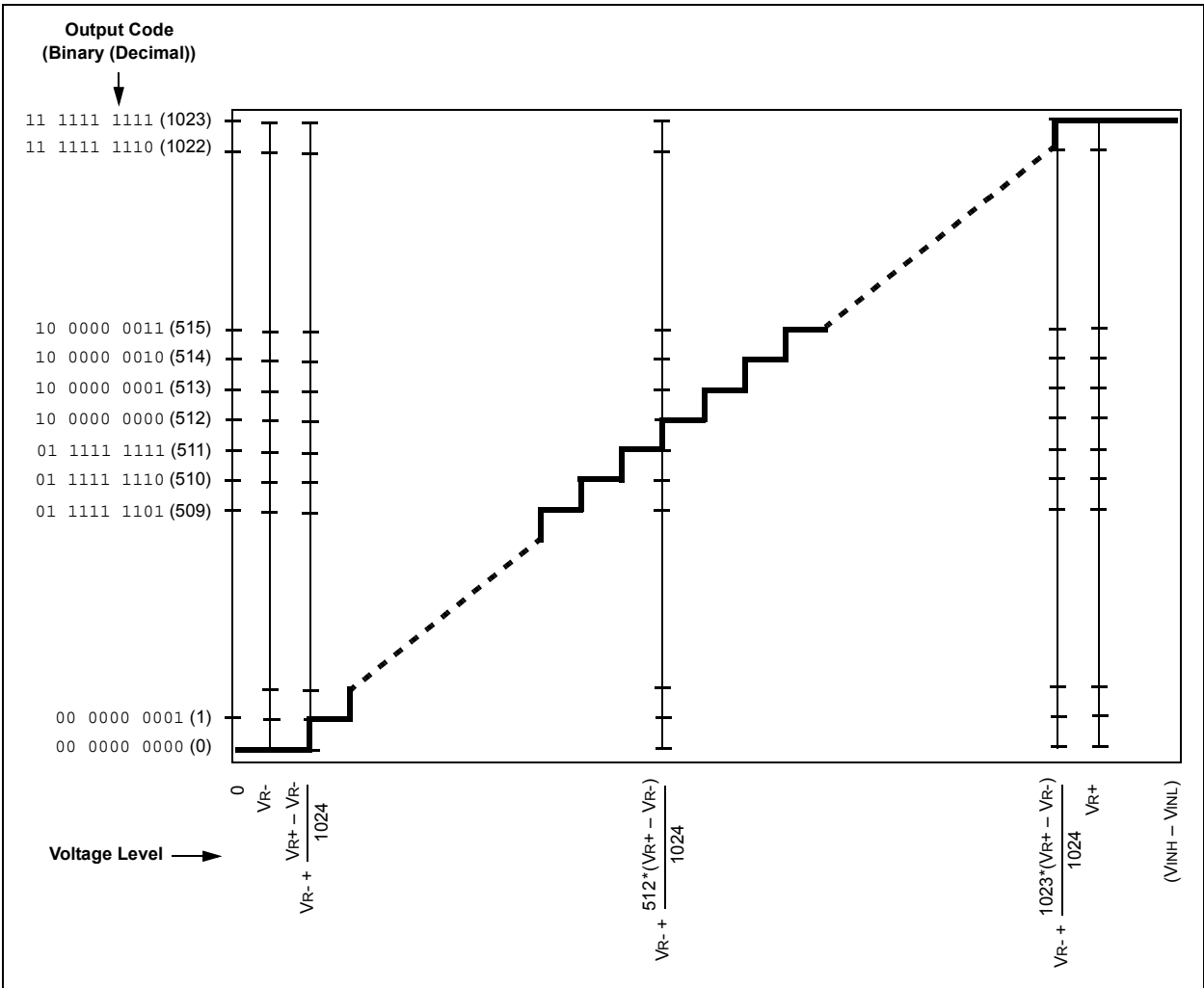

FIGURE 23-3: A/D TRANSFER FUNCTION



PIC24FJ256DA210 FAMILY

[查询PIC24FJ256DA106供应商](#)

NOTES:

PIC24FJ256DA210 FAMILY

[查询PIC24FJ256DA106供应商](#)

24.0 TRIPLE COMPARATOR MODULE

Note: This data sheet summarizes the features of this group of PIC24F devices. It is not intended to be a comprehensive reference source. For more information, refer to the associated "PIC24F Family Reference Manual".

The triple comparator module provides three dual input comparators. The inputs to the comparator can be configured to use any one of five external analog inputs (CxINA, CxINB, CxINC, CxIND and VREF+) and a voltage reference input from one of the internal band gap references or the comparator voltage reference generator (V_{BG}, V_{BG}/2, V_{BG}/6 and CVREF).

The comparator outputs may be directly connected to the CxOUT pins. When the respective COE equals '1', the I/O pad logic makes the unsynchronized output of the comparator available on the pin.

A simplified block diagram of the module is shown in Figure 24-1. Diagrams of the possible individual comparator configurations are shown in Figure 24-2.

Each comparator has its own control register, CMxCON (Register 24-1), for enabling and configuring its operation. The output and event status of all three comparators is provided in the CMSTAT register (Register 24-2).

FIGURE 24-1: TRIPLE COMPARATOR MODULE BLOCK DIAGRAM

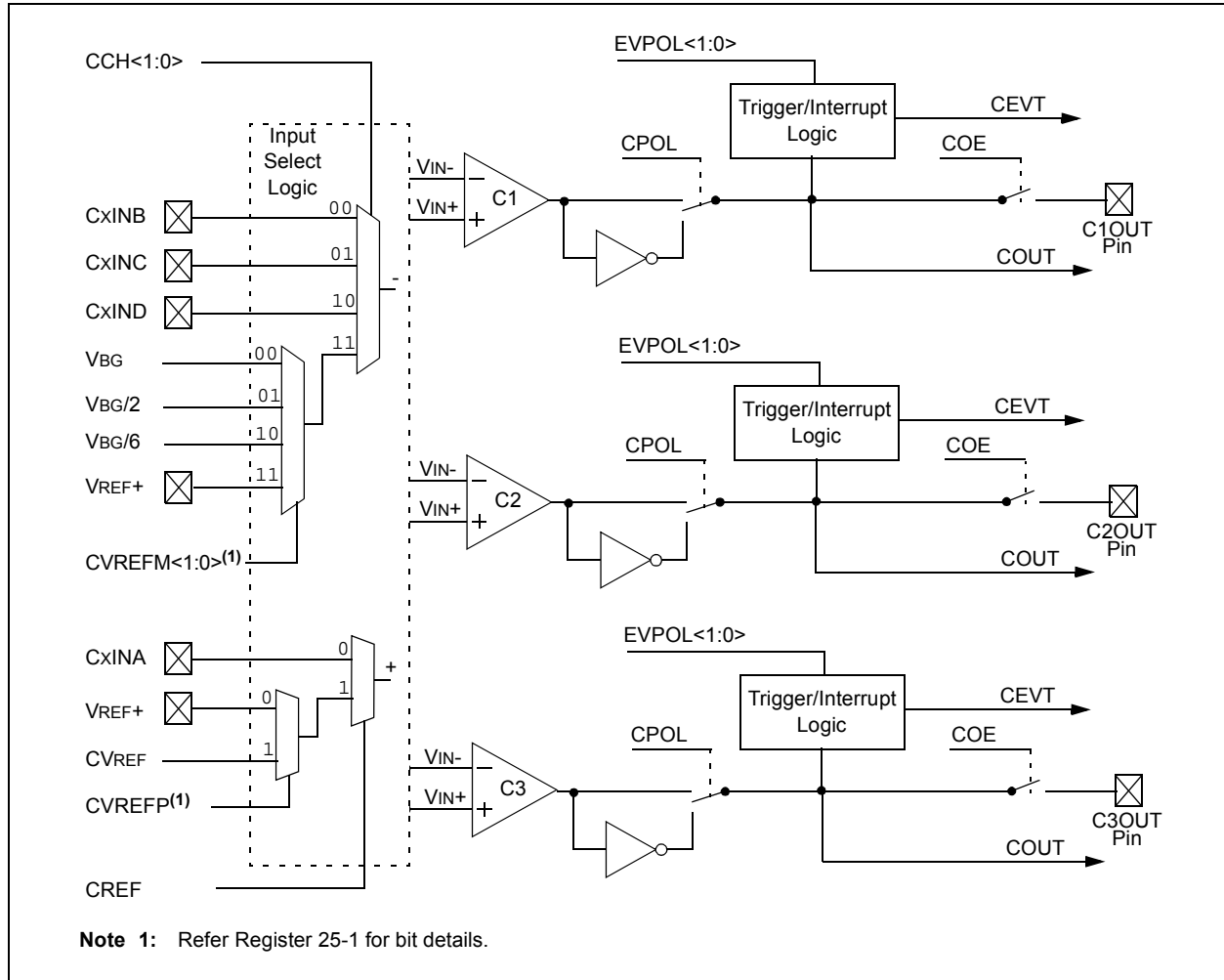

PIC24FJ256DA210 FAMILY

[查询PIC24FJ256DA106供应商](#)

FIGURE 24-2: INDIVIDUAL COMPARATOR CONFIGURATIONS WHEN CREF = 0

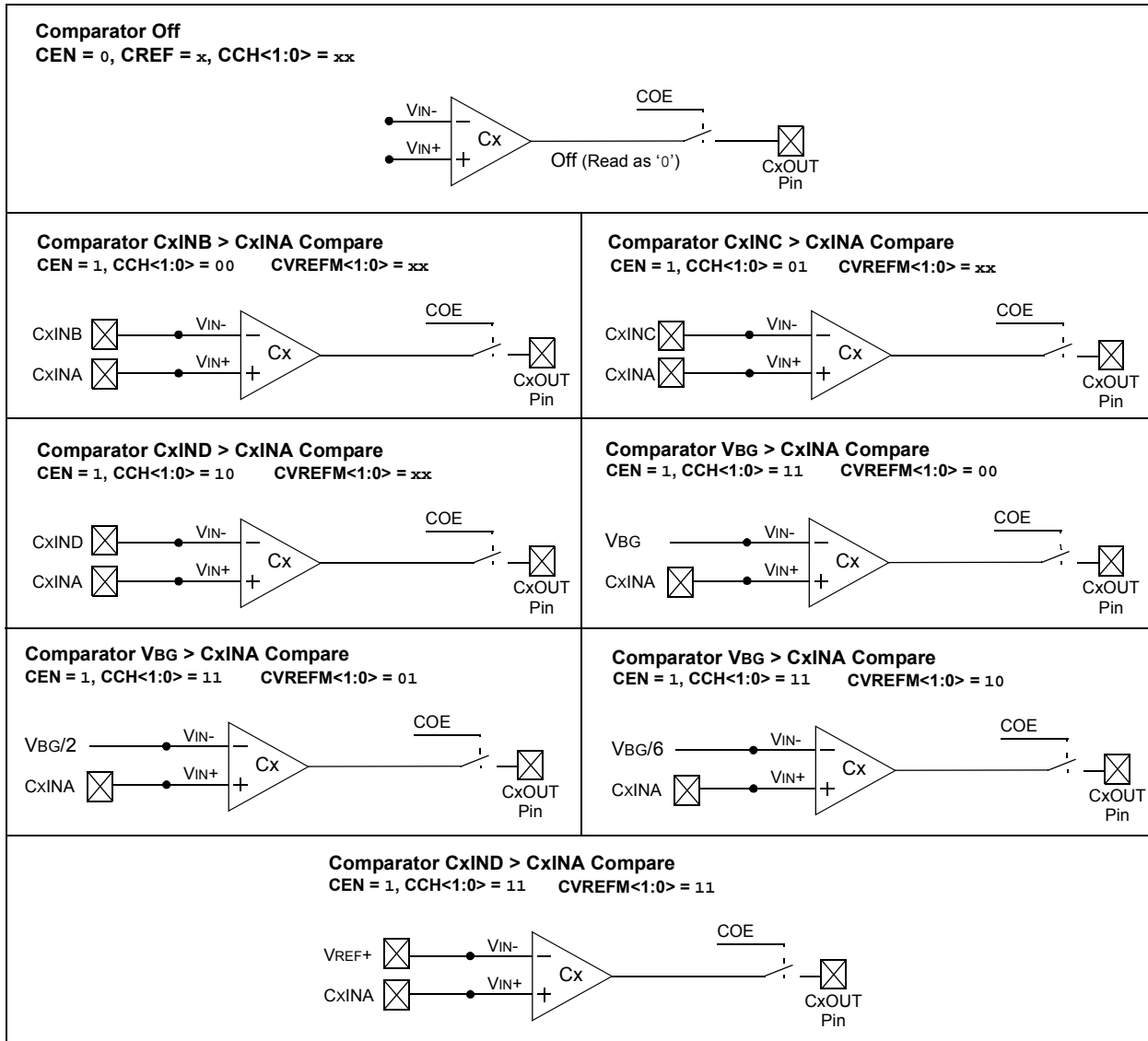

PIC24FJ256DA210 FAMILY

查询PIC24FJ256DA106供应商

FIGURE 24-3: INDIVIDUAL COMPARATOR CONFIGURATIONS WHEN CREF = 1 AND CVREFP = 0

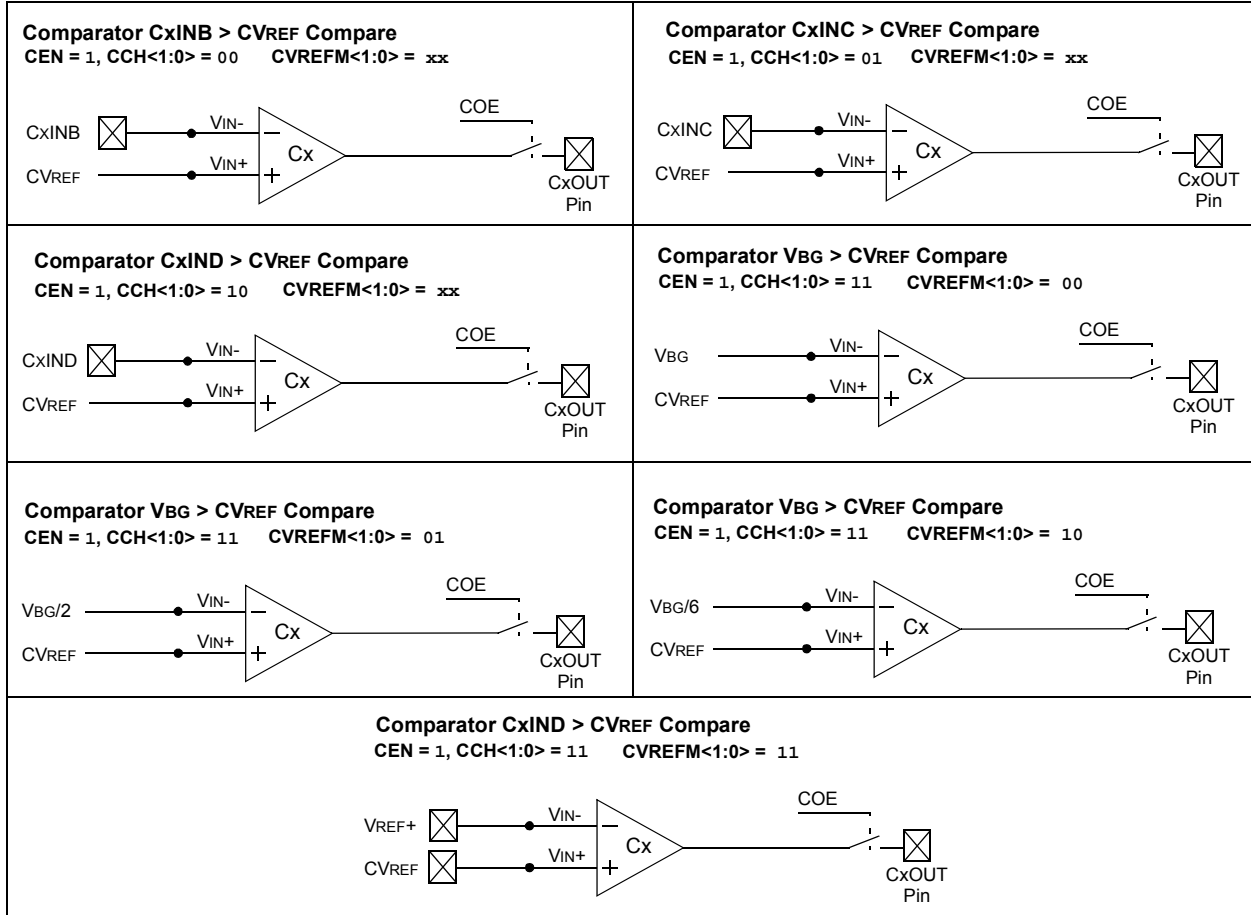
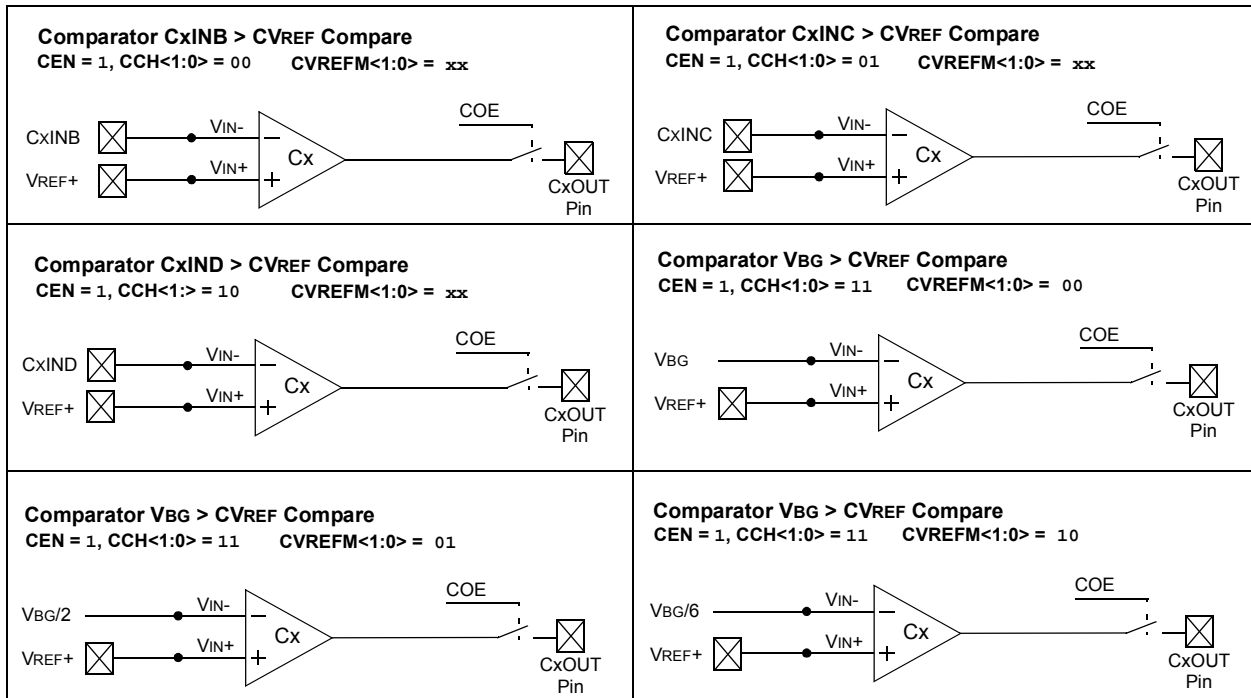

FIGURE 24-4: INDIVIDUAL COMPARATOR CONFIGURATIONS WHEN CREF = 1 AND CVREFP = 1



PIC24FJ256DA210 FAMILY

[查询PIC24FJ256DA106供应商](#)

REGISTER 24-1: CMxCON: COMPARATOR x CONTROL REGISTERS (COMPARATORS 1 THROUGH 3)

| | | | | | | | |
|--------|-------|-------|-----|-----|-----|-----------|----------|
| R/W-0 | R/W-0 | R/W-0 | U-0 | U-0 | U-0 | R/W-0, HS | R-0, HSC |
| CEN | COE | CPOL | — | — | — | CEVT | COUT |
| bit 15 | | | | | | bit 8 | |

| | | | | | | | |
|--------|--------|-----|-------|-----|-----|-------|-------|
| R/W-0 | R/W-0 | U-0 | R/W-0 | U-0 | U-0 | R/W-0 | R/W-0 |
| EVPOL1 | EVPOL0 | — | CREF | — | — | CCH1 | CCH0 |
| bit 7 | | | | | | bit 0 | |

| | | |
|-------------------|----------------------------|--|
| Legend: | HS = Hardware Settable bit | HSC = Hardware Settable/Clearable bit |
| R = Readable bit | W = Writable bit | U = Unimplemented bit, read as '0' |
| -n = Value at POR | '1' = Bit is set | '0' = Bit is cleared x = Bit is unknown |

- bit 15 **CEN:** Comparator Enable bit
 1 = Comparator is enabled
 0 = Comparator is disabled
- bit 14 **COE:** Comparator Output Enable bit
 1 = Comparator output is present on the CxOUT pin
 0 = Comparator output is internal only
- bit 13 **CPOL:** Comparator Output Polarity Select bit
 1 = Comparator output is inverted
 0 = Comparator output is not inverted
- bit 12-10 **Unimplemented:** Read as '0'
- bit 9 **CEVT:** Comparator Event bit
 1 = Comparator event that is defined by EVPOL<1:0> has occurred; subsequent triggers and interrupts are disabled until the bit is cleared
 0 = Comparator event has not occurred
- bit 8 **COUT:** Comparator Output bit
When CPOL = 0:
 1 = $V_{IN+} > V_{IN-}$
 0 = $V_{IN+} < V_{IN-}$
When CPOL = 1:
 1 = $V_{IN+} < V_{IN-}$
 0 = $V_{IN+} > V_{IN-}$
- bit 7-6 **EVPOL<1:0>:** Trigger/Event/Interrupt Polarity Select bits
 11 = Trigger/event/interrupt is generated on any change of the comparator output (while CEVT = 0)
 10 = Trigger/event/interrupt is generated on transition of the comparator output:
 If CPOL = 0 (non-inverted polarity):
 High-to-low transition only.
 If CPOL = 1 (inverted polarity):
 Low-to-high transition only.
 01 = Trigger/event/interrupt is generated on transition of comparator output:
 If CPOL = 0 (non-inverted polarity):
 Low-to-high transition only.
 If CPOL = 1 (inverted polarity):
 High-to-low transition only.
 00 = Trigger/event/interrupt generation is disabled
- bit 5 **Unimplemented:** Read as '0'

PIC24FJ256DA210 FAMILY

[查询PIC24FJ256DA106供应商](#)

REGISTER 24-1: CMxCON: COMPARATOR x CONTROL REGISTERS (COMPARATORS 1 THROUGH 3) (CONTINUED)

- bit 4 **CREF:** Comparator Reference Select bits (non-inverting input)
 1 = Non-inverting input connects to the internal CVREF voltage
 0 = Non-inverting input connects to the CxINA pin
- bit 3-2 **Unimplemented:** Read as '0'
- bit 1-0 **CCH<1:0>:** Comparator Channel Select bits
 11 = Inverting input of the comparator connects to the internal selectable reference voltage specified by the CVREFM<1:0> bits in the CVRCON register
 10 = Inverting input of the comparator connects to the CxIND pin
 01 = Inverting input of the comparator connects to the CxINC pin
 00 = Inverting input of the comparator connects to the CxINB pin

REGISTER 24-2: CMSTAT: COMPARATOR MODULE STATUS REGISTER

| | | | | | | | |
|--------|-----|-----|-----|-----|----------|----------|----------|
| R/W-0 | U-0 | U-0 | U-0 | U-0 | R-0, HSC | R-0, HSC | R-0, HSC |
| CMIDL | — | — | — | — | C3EVT | C2EVT | C1EVT |
| bit 15 | | | | | | | bit 8 |

| | | | | | | | |
|-------|-----|-----|-----|-----|----------|----------|----------|
| U-0 | U-0 | U-0 | U-0 | U-0 | R-0, HSC | R-0, HSC | R-0, HSC |
| — | — | — | — | — | C3OUT | C2OUT | C1OUT |
| bit 7 | | | | | | | bit 0 |

| | | | |
|-------------------|---------------------------------------|------------------------------------|--------------------|
| Legend: | HSC = Hardware Settable/Clearable bit | | |
| R = Readable bit | W = Writable bit | U = Unimplemented bit, read as '0' | |
| -n = Value at POR | '1' = Bit is set | '0' = Bit is cleared | x = Bit is unknown |

- bit 15 **CMIDL:** Comparator Stop in Idle Mode bit
 1 = Discontinue operation of all comparators when device enters Idle mode
 0 = Continue operation of all enabled comparators in Idle mode
- bit 14-11 **Unimplemented:** Read as '0'
- bit 10 **C3EVT:** Comparator 3 Event Status bit (read-only)
 Shows the current event status of Comparator 3 (CM3CON<9>).
- bit 9 **C2EVT:** Comparator 2 Event Status bit (read-only)
 Shows the current event status of Comparator 2 (CM2CON<9>).
- bit 8 **C1EVT:** Comparator 1 Event Status bit (read-only)
 Shows the current event status of Comparator 1 (CM1CON<9>).
- bit 7-3 **Unimplemented:** Read as '0'
- bit 2 **C3OUT:** Comparator 3 Output Status bit (read-only)
 Shows the current output of Comparator 3 (CM3CON<8>).
- bit 1 **C2OUT:** Comparator 2 Output Status bit (read-only)
 Shows the current output of Comparator 2 (CM2CON<8>).
- bit 0 **C1OUT:** Comparator 1 Output Status bit (read-only)
 Shows the current output of Comparator 1 (CM1CON<8>).

PIC24FJ256DA210 FAMILY

[查询PIC24FJ256DA106供应商](#)

NOTES:

PIC24FJ256DA210 FAMILY

[查询PIC24FJ256DA106供应商](#)

25.0 COMPARATOR VOLTAGE REFERENCE

Note: This data sheet summarizes the features of this group of PIC24F devices. It is not intended to be a comprehensive reference source. For more information, refer to the “PIC24F Family Reference Manual”, **Section 19. “Comparator Module”** (DS39710). The information in this data sheet supersedes the information in the FRM.

25.1 Configuring the Comparator Voltage Reference

The voltage reference module is controlled through the CVRCON register (Register 25-1). The comparator voltage reference provides two ranges of output voltage, each with 16 distinct levels. The range to be used is selected by the CVRR bit (CVRCON<5>). The primary difference between the ranges is the size of the steps selected by the CVREF Selection bits (CVR<3:0>), with one range offering finer resolution.

The comparator reference supply voltage can come from either VDD and VSS, or the external VREF+ and VREF-. The voltage source is selected by the CVRSS bit (CVRCON<4>).

The settling time of the comparator voltage reference must be considered when changing the CVREF output.

FIGURE 25-1: COMPARATOR VOLTAGE REFERENCE BLOCK DIAGRAM

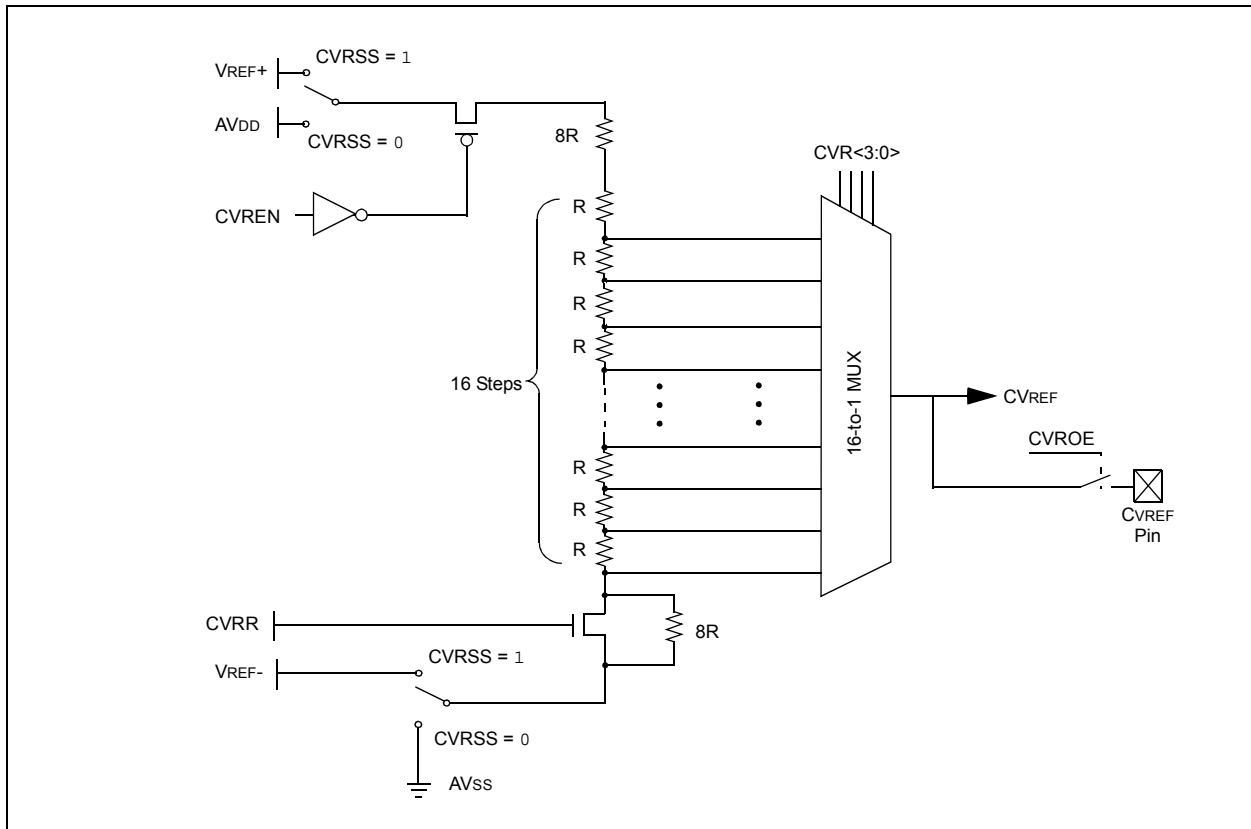

PIC24FJ256DA210 FAMILY

[查询PIC24FJ256DA106供应商](#)

REGISTER 25-1: CVRCON: COMPARATOR VOLTAGE REFERENCE CONTROL REGISTER

| | | | | | | | |
|--------|-----|-----|-----|-----|--------|---------|---------|
| U-0 | U-0 | U-0 | U-0 | U-0 | R/W-0 | R/W-0 | R/W-0 |
| — | — | — | — | — | CVREFP | CVREFM1 | CVREFM0 |
| bit 15 | | | | | bit 8 | | |

| | | | | | | | |
|-------|-------|-------|-------|-------|-------|-------|-------|
| R/W-0 | R/W-0 | R/W-0 | R/W-0 | R/W-0 | R/W-0 | R/W-0 | R/W-0 |
| CVREN | CVROE | CVRR | CVRSS | CVR3 | CVR2 | CVR1 | CVR0 |
| bit 7 | | | | | bit 0 | | |

Legend:

R = Readable bit

W = Writable bit

U = Unimplemented bit, read as '0'

-n = Value at POR

'1' = Bit is set

'0' = Bit is cleared

x = Bit is unknown

- bit 15-11 **Unimplemented:** Read as '0'
- bit 10 **CVREFP:** Voltage Reference Select bit (valid only when CREF is '1')
- 1 = VREF+ is used as a reference voltage to the comparators
 - 0 = The CVR (4-bit DAC) within this module provides the the reference voltage to the comparators
- bit 9-8 **CVREFM<1:0>:** Band Gap Reference Source Select bits (valid only when CCH<1:0> = 11)
- 00 = Band gap voltage is provided as an input to the comparators
 - 01 = Band gap voltage divided-by-two is provided as an input to the comparators
 - 10 = Band gap voltage divided-by-six is provided as an input to the comparators
 - 11 = VREF+ pin is provided as an input the comparators
- bit 7 **CVREN:** Comparator Voltage Reference Enable bit
- 1 = CVREF circuit is powered on
 - 0 = CVREF circuit is powered down
- bit 6 **CVROE:** Comparator VREF Output Enable bit
- 1 = CVREF voltage level is output on the CVREF pin
 - 0 = CVREF voltage level is disconnected from the CVREF pin
- bit 5 **CVRR:** Comparator VREF Range Selection bit
- 1 = CVRSRC range should be 0 to 0.625 CVRSRC with CVRSRC/24 step size
 - 0 = CVRSRC range should be 0.25 to 0.719 CVRSRC with CVRSRC/32 step size
- bit 4 **CVRSS:** Comparator VREF Source Selection bit
- 1 = Comparator reference source CVRSRC = VREF+ – VREF-
 - 0 = Comparator reference source CVRSRC = AVDD – AVSS
- bit 3-0 **CVR<3:0>:** Comparator VREF Value Selection $0 \leq \text{CVR}<3:0> \leq 15$ bits
- When CVRR = 1:
 $\text{CVREF} = (\text{CVR}<3:0>/24) \cdot (\text{CVRSRC})$
- When CVRR = 0:
 $\text{CVREF} = 1/4 \cdot (\text{CVRSRC}) + (\text{CVR}<3:0>/32) \cdot (\text{CVRSRC})$

PIC24FJ256DA210 FAMILY

[查询PIC24FJ256DA106供应商](#)

26.0 CHARGE TIME MEASUREMENT UNIT (CTMU)

Note: This data sheet summarizes the features of this group of PIC24F devices. It is not intended to be a comprehensive reference source. For more information, refer to the associated “PIC24F Family Reference Manual”, Section 11. “Charge Time Measurement Unit (CTMU)” (DS39724). The information in this data sheet supersedes the information in the FRM.

The Charge Time Measurement Unit (CTMU) is a flexible analog module that provides accurate differential time measurement between pulse sources, as well as asynchronous pulse generation. Its key features include:

- Four edge input trigger sources
- Polarity control for each edge source
- Control of edge sequence
- Control of response to edges
- Time measurement resolution of 1 nanosecond
- Accurate current source suitable for capacitive measurement

Together with other on-chip analog modules, the CTMU can be used to precisely measure time, measure capacitance, measure relative changes in capacitance or generate output pulses that are independent of the system clock. The CTMU module is ideal for interfacing with capacitive-based sensors.

The CTMU is controlled through two registers: CTMUCON and CTMUICON. CTMUCON enables the module, and controls edge source selection, edge

source polarity selection, and edge sequencing. The CTMUICON register controls the selection and trim of the current source.

26.1 Measuring Capacitance

The CTMU module measures capacitance by generating an output pulse with a width equal to the time between edge events on two separate input channels. The pulse edge events to both input channels can be selected from four sources: two internal peripheral modules (OC1 and Timer1) and two external pins (CTEDG1 and CTEDG2). This pulse is used with the module’s precision current source to calculate capacitance according to the relationship:

$$C = I \cdot \frac{dV}{dT}$$

For capacitance measurements, the A/D Converter samples an external capacitor (CAPP) on one of its input channels after the CTMU output’s pulse. A precision resistor (RPR) provides current source calibration on a second A/D channel. After the pulse ends, the converter determines the voltage on the capacitor. The actual calculation of capacitance is performed in software by the application.

Figure 26-1 shows the external connections used for capacitance measurements, and how the CTMU and A/D modules are related in this application. This example also shows the edge events coming from Timer1, but other configurations using external edge sources are possible. A detailed discussion on measuring capacitance and time with the CTMU module is provided in the “PIC24F Family Reference Manual”.

FIGURE 26-1: TYPICAL CONNECTIONS AND INTERNAL CONFIGURATION FOR CAPACITANCE MEASUREMENT

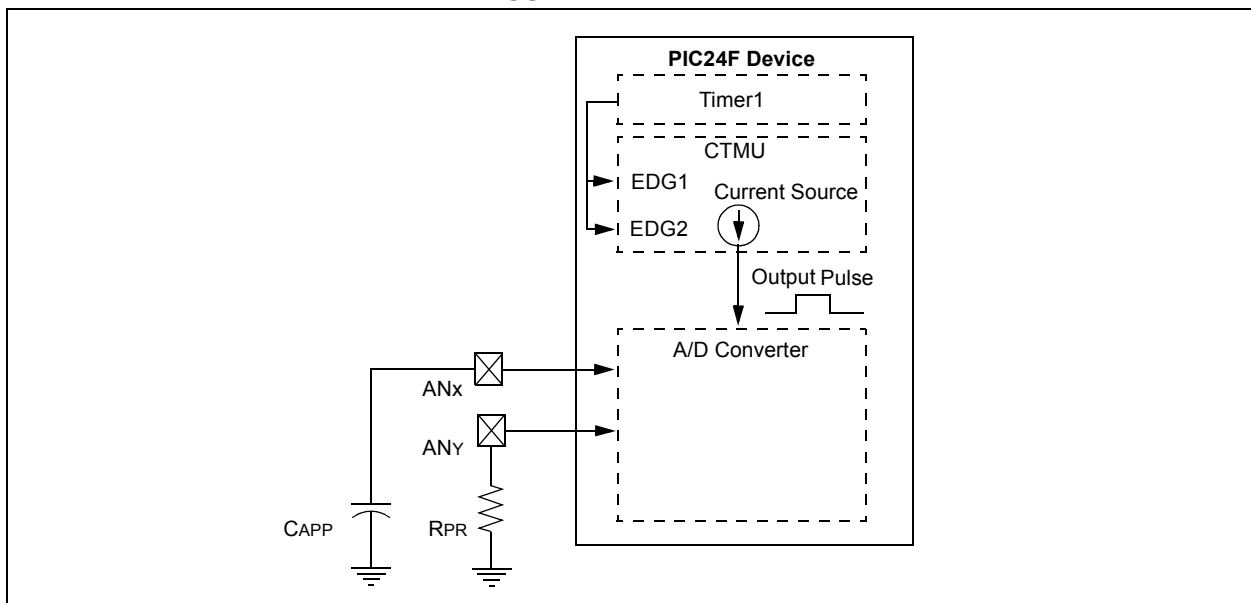

PIC24FJ256DA210 FAMILY

[查询PIC24FJ256DA106供应商](#)

26.2 Measuring Time

Time measurements on the pulse width can be similarly performed using the A/D module's internal capacitor (CAD) and a precision resistor for current calibration. Figure 26-2 shows the external connections used for time measurements, and how the CTMU and A/D modules are related in this application. This example also shows both edge events coming from the external CTEDG pins, but other configurations using internal edge sources are possible. A detailed discussion on measuring capacitance and time with the CTMU module is provided in the "PIC24F Family Reference Manual".

26.3 Pulse Generation and Delay

The CTMU module can also generate an output pulse with edges that are not synchronous with the device's system clock. More specifically, it can generate a pulse with a programmable delay from an edge event input to the module.

When the module is configured for pulse generation delay by setting the TGEN (CTMUCON<12>) bit, the internal current source is connected to the B input of Comparator 2. A capacitor (CDELAY) is connected to the Comparator 2 pin, C2INB, and the comparator voltage reference, CVREF, is connected to C2INA. CVREF is then configured for a specific trip point. The module begins to charge CDELAY when an edge event is detected. When CDELAY charges above the CVREF trip point, a pulse is output on CTPLS. The length of the pulse delay is determined by the value of CDELAY and the CVREF trip point.

Figure 26-3 shows the external connections for pulse generation, as well as the relationship of the different analog modules required. While CTEDG1 is shown as the input pulse source, other options are available. A detailed discussion on pulse generation with the CTMU module is provided in the "PIC24F Family Reference Manual".

FIGURE 26-2: TYPICAL CONNECTIONS AND INTERNAL CONFIGURATION FOR TIME MEASUREMENT TIME

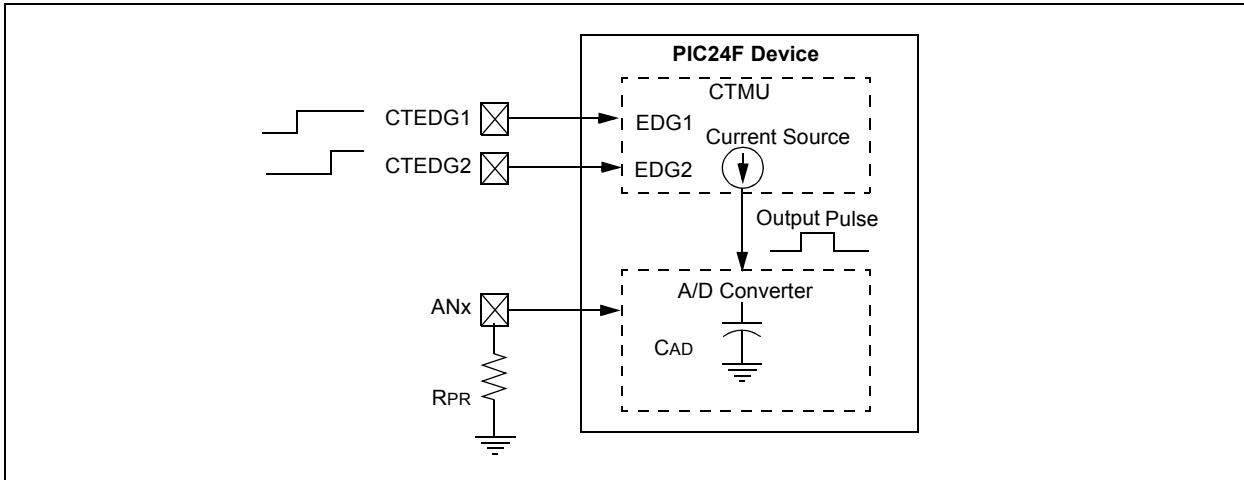
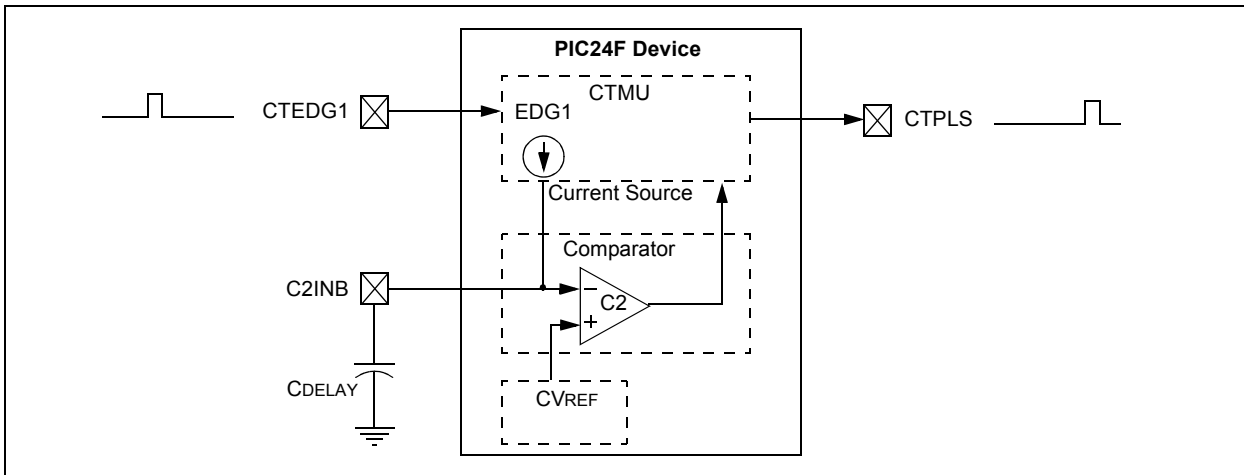

FIGURE 26-3: TYPICAL CONNECTIONS AND INTERNAL CONFIGURATION FOR PULSE DELAY GENERATION



PIC24FJ256DA210 FAMILY

[查询PIC24FJ256DA106供应商](#)

REGISTER 26-1: CTMUCON: CTMU CONTROL REGISTER

| | | | | | | | |
|--------|-----|----------|---------------------|-------|----------|---------|--------|
| R/W-0 | U-0 | R/W-0 | R/W-0 | R/W-0 | R/W-0 | R/W-0 | R/W-0 |
| CTMUEN | — | CTMUSIDL | TGEN ⁽¹⁾ | EDGEN | EDGSEQEN | IDISSEN | CTTRIG |
| bit 15 | | | | | | | bit 8 |

| | | | | | | | |
|---------|----------|----------|---------|----------|----------|------------|------------|
| R/W-0 | R/W-0 | R/W-0 | R/W-0 | R/W-0 | R/W-0 | R/W-0, HSC | R/W-0, HSC |
| EDG2POL | EDG2SEL1 | EDG2SEL0 | EDG1POL | EDG1SEL1 | EDG1SEL0 | EDG2STAT | EDG1STAT |
| bit 7 | | | | | | | bit 0 |

| | | | |
|-------------------|---------------------------------------|------------------------------------|--------------------|
| Legend: | HSC = Hardware Settable/Clearable bit | | |
| R = Readable bit | W = Writable bit | U = Unimplemented bit, read as '0' | |
| -n = Value at POR | '1' = Bit is set | '0' = Bit is cleared | x = Bit is unknown |

- bit 15 **CTMUEN:** CTMU Enable bit
1 = Module is enabled
0 = Module is disabled
- bit 14 **Unimplemented:** Read as '0'
- bit 13 **CTMUSIDL:** Stop in Idle Mode bit
1 = Discontinue module operation when the device enters Idle mode
0 = Continue module operation in Idle mode
- bit 12 **TGEN:** Time Generation Enable bit⁽¹⁾
1 = Enables edge delay generation
0 = Disables edge delay generation
- bit 10 **EDGEN:** Edge Enable bit
1 = Edges are not blocked
0 = Edges are blocked
- bit 10 **EDGSEQEN:** Edge Sequence Enable bit
1 = Edge 1 event must occur before Edge 2 event can occur
0 = No edge sequence is needed
- bit 9 **IDISSEN:** Analog Current Source Control bit
1 = Analog current source output is grounded
0 = Analog current source output is not grounded
- bit 8 **CTTRIG:** Trigger Control bit
1 = Trigger output is enabled
0 = Trigger output is disabled
- bit 7 **EDG2POL:** Edge 2 Polarity Select bit
1 = Edge 2 is programmed for a positive edge response
0 = Edge 2 is programmed for a negative edge response
- bit 6-5 **EDG2SEL<1:0>:** Edge 2 Source Select bits
11 = CTEDG1 pin
10 = CTEDG2 pin
01 = OC1 module
00 = Timer1 module
- bit 4 **EDG1POL:** Edge 1 Polarity Select bit
1 = Edge 1 is programmed for a positive edge response
0 = Edge 1 is programmed for a negative edge response

Note 1: If TGEN = 1, the peripheral inputs and outputs must be configured to an available RPN/RPIN pin. See **Section 10.4 "Peripheral Pin Select (PPS)"** for more information.

PIC24FJ256DA210 FAMILY

[查询PIC24FJ256DA106供应商](#)

REGISTER 26-1: CTMUCON: CTMU CONTROL REGISTER (CONTINUED)

bit 3-2 **EDG1SEL<1:0>**: Edge 1 Source Select bits

11 = CTEDG1 pin
 10 = CTEDG2 pin
 01 = OC1 module
 00 = Timer1 module

bit 1 **EDG2STAT**: Edge 2 Status bit

1 = Edge 2 event has occurred
 0 = Edge 2 event has not occurred

bit 0 **EDG1STAT**: Edge 1 Status bit

1 = Edge 1 event has occurred
 0 = Edge 1 event has not occurred

Note 1: If TGEN = 1, the peripheral inputs and outputs must be configured to an available RPN/RPIN pin. See Section 10.4 “Peripheral Pin Select (PPS)” for more information.

REGISTER 26-2: CTMUICON: CTMU CURRENT CONTROL REGISTER

| | | | | | | | |
|--------|--------|--------|--------|--------|--------|-------|-------|
| R/W-0 | R/W-0 | R/W-0 | R/W-0 | R/W-0 | R/W-0 | R/W-0 | R/W-0 |
| ITRIM5 | ITRIM4 | ITRIM3 | ITRIM2 | ITRIM1 | ITRIM0 | IRNG1 | IRNG0 |
| bit 15 | | | | | | bit 8 | |

| | | | | | | | |
|-------|-----|-----|-----|-----|-----|-------|-----|
| U-0 | U-0 | U-0 | U-0 | U-0 | U-0 | U-0 | U-0 |
| — | — | — | — | — | — | — | — |
| bit 7 | | | | | | bit 0 | |

Legend:

R = Readable bit W = Writable bit U = Unimplemented bit, read as '0'
 -n = Value at POR '1' = Bit is set '0' = Bit is cleared x = Bit is unknown

bit 15-10 **ITRIM<5:0>**: Current Source Trim bits

011111 = Maximum positive change from nominal current
 011110
 .
 .
 .
 000001 = Minimum positive change from nominal current
 000000 = Nominal current output specified by IRNG<1:0>
 111111 = Minimum negative change from nominal current
 .
 .
 .
 100010
 100001 = Maximum negative change from nominal current

bit 9-8 **IRNG<1:0>**: Current Source Range Select bits

11 = 100 × Base Current
 10 = 10 × Base Current
 01 = Base current level (0.55 μA nominal)
 00 = Current source is disabled

bit 7-0 **Unimplemented**: Read as '0'

PIC24FJ256DA210 FAMILY

[查询PIC24FJ256DA106供应商](#)

27.0 SPECIAL FEATURES

Note: This data sheet summarizes the features of this group of PIC24F devices. It is not intended to be a comprehensive reference source. For more information, refer to the following sections of the “*PIC24F Family Reference Manual*”. The information in this data sheet supersedes the information in the FRMs.

- **Section 9. “Watchdog Timer (WDT)”** (DS39697)
- **Section 32. “High-Level Device Integration”** (DS39719)
- **Section 33. “Programming and Diagnostics”** (DS39716)

PIC24FJ256DA210 family devices include several features intended to maximize application flexibility and reliability, and minimize cost through elimination of external components. These are:

- Flexible Configuration
- Watchdog Timer (WDT)
- Code Protection
- JTAG Boundary Scan Interface
- In-Circuit Serial Programming™
- In-Circuit Emulation

27.1 Configuration Bits

The Configuration bits can be programmed (read as ‘0’), or left unprogrammed (read as ‘1’), to select various device configurations. These bits are mapped starting at program memory location F8000h. A detailed explanation of the various bit functions is provided in Register 27-1 through Register 27-6.

Note that address F8000h is beyond the user program memory space. In fact, it belongs to the configuration memory space (80000h-FFFFFFh) which can only be accessed using table reads and table writes.

27.1.1 CONSIDERATIONS FOR CONFIGURING PIC24FJ256DA210 FAMILY DEVICES

In PIC24FJ256DA210 family devices, the configuration bytes are implemented as volatile memory. This means that configuration data must be programmed each time the device is powered up. Configuration data is stored in the three words at the top of the on-chip program memory space, known as the Flash Configuration Words. Their specific locations are shown in Table 27-1. These are packed representations of the actual device Configuration bits, whose actual locations are distributed among several locations in configuration space. The configuration data is automatically loaded from the Flash Configuration Words to the proper Configuration registers during device Resets.

Note: Configuration data is reloaded on all types of device Resets.

When creating applications for these devices, users should always specifically allocate the location of the Flash Configuration Word for configuration data. This is to make certain that program code is not stored in this address when the code is compiled.

The upper byte of all Flash Configuration Words in program memory should always be ‘0000 0000’. This makes them appear to be NOP instructions in the remote event that their locations are ever executed by accident. Since Configuration bits are not implemented in the corresponding locations, writing ‘0’s to these locations has no effect on device operation.

Note: Performing a page erase operation on the last page of program memory clears the Flash Configuration Words, enabling code protection as a result. Therefore, users should avoid performing page erase operations on the last page of program memory.

TABLE 27-1: FLASH CONFIGURATION WORD LOCATIONS FOR PIC24FJ256DA210 FAMILY DEVICES

| Device | Configuration Word Addresses | | | |
|-----------------|------------------------------|--------|--------|--------|
| | 1 | 2 | 3 | 4 |
| PIC24FJ128DAXXX | 157FEh | 157FCh | 157FAh | 157F8h |
| PIC24FJ256DAXXX | 2ABFEh | 2ABFCh | 2ABFAh | 2ABF8h |

PIC24FJ256DA210 FAMILY

查询PIC24FJ256DA106供应商

REGISTER 27-1: CW1: FLASH CONFIGURATION WORD 1

| | | | | | | | |
|--------|-----|-----|-----|-----|-----|-----|--------|
| U-0 | U-0 | U-0 | U-0 | U-0 | U-0 | U-0 | U-0 |
| — | — | — | — | — | — | — | — |
| bit 23 | | | | | | | bit 16 |

| | | | | | | | |
|----------|--------|--------|--------|--------|----------|--------|--------|
| r-x | R/PO-1 | R/PO-1 | R/PO-1 | R/PO-1 | r-1 | R/PO-1 | R/PO-1 |
| reserved | JTAGEN | GCP | GWRP | DEBUG | reserved | ICS1 | ICS0 |
| bit 15 | | | | | | | bit 8 |

| | | | | | | | |
|--------|--------|------------------------|--------|--------|--------|--------|--------|
| R/PO-1 | R/PO-1 | R/PO-1 | R/PO-1 | R/PO-1 | R/PO-1 | R/PO-1 | R/PO-1 |
| FWDTEN | WINDIS | ALTVREF ⁽¹⁾ | FWPSA | WDTPS3 | WDTPS2 | WDTPS1 | WDTPS0 |
| bit 7 | | | | | | | bit 0 |

| | | | |
|-------------------|------------------|------------------------------------|--------------------|
| Legend: | r = Reserved bit | | |
| R = Readable bit | W = Writable bit | U = Unimplemented bit, read as '0' | |
| -n = Value at POR | '1' = Bit is set | '0' = Bit is cleared | x = Bit is unknown |

- bit 23-16 **Unimplemented:** Read as '1'
- bit 15 **Reserved:** The value is unknown; program as '0'
- bit 14 **JTAGEN:** JTAG Port Enable bit
 - 1 = JTAG port is enabled
 - 0 = JTAG port is disabled
- bit 13 **GCP:** General Segment Program Memory Code Protection bit
 - 1 = Code protection is disabled
 - 0 = Code protection is enabled for the entire program memory space
- bit 12 **GWRP:** General Segment Code Flash Write Protection bit
 - 1 = Writes to program memory are allowed
 - 0 = Writes to program memory are not allowed
- bit 11 **DEBUG:** Background Debugger Enable bit
 - 1 = Device resets into Operational mode
 - 0 = Device resets into Debug mode
- bit 10 **Reserved:** Always maintain as '1'
- bit 9-8 **ICS<1:0>:** Emulator Pin Placement Select bits
 - 11 = Emulator functions are shared with PGEC1/PGED1
 - 10 = Emulator functions are shared with PGEC2/PGED2
 - 01 = Emulator functions are shared with PGEC3/PGED3
 - 00 = Reserved; do not use
- bit 7 **FWDTEN:** Watchdog Timer Enable bit
 - 1 = Watchdog Timer is enabled
 - 0 = Watchdog Timer is disabled
- bit 6 **WINDIS:** Windowed Watchdog Timer Disable bit
 - 1 = Standard Watchdog Timer is enabled
 - 0 = Windowed Watchdog Timer is enabled; FWDTEN must be '1'
- bit 5 **ALTVREF:** Alternate VREF Pin Selection bit⁽¹⁾
 - 1 = VREF is on a default pin (VREF+ on RA10 and VREF- on RA9)
 - 0 = VREF is on an alternate pin (VREF+ on RB0 and VREF- on RB1)

Note 1: Unimplemented in 64-pin devices, maintain at '1' (VREF+ on RB0 and VREF- on RB1).

PIC24FJ256DA210 FAMILY

[查询PIC24FJ256DA106供应商](#)

REGISTER 27-1: CW1: FLASH CONFIGURATION WORD 1 (CONTINUED)

bit 4 **FWPSA:** WDT Prescaler Ratio Select bit
 1 = Prescaler ratio of 1:128
 0 = Prescaler ratio of 1:32

bit 3-0 **WDTPS<3:0>:** Watchdog Timer Postscaler Select bits
 1111 = 1:32,768
 1110 = 1:16,384
 1101 = 1:8,192
 1100 = 1:4,096
 1011 = 1:2,048
 1010 = 1:1,024
 1001 = 1:512
 1000 = 1:256
 0111 = 1:128
 0110 = 1:64
 0101 = 1:32
 0100 = 1:16
 0011 = 1:8
 0010 = 1:4
 0001 = 1:2
 0000 = 1:1

Note 1: Unimplemented in 64-pin devices, maintain at '1' (VREF+ on RB0 and VREF- on RB1).

PIC24FJ256DA210 FAMILY

[查询PIC24FJ256DA106供应商](#)

REGISTER 27-2: CW2: FLASH CONFIGURATION WORD 2

| | | | | | | | |
|--------|-----|-----|-----|-----|-----|-----|--------|
| U-0 | U-0 | U-0 | U-0 | U-0 | U-0 | U-0 | U-0 |
| — | — | — | — | — | — | — | — |
| bit 23 | | | | | | | bit 16 |

| | | | | | | | |
|--------|---------|---------|---------|----------|--------|--------|--------|
| R/PO-1 | R/PO-1 | R/PO-1 | R/PO-1 | R/PO-1 | R/PO-1 | R/PO-1 | R/PO-1 |
| IESO | PLLDIV2 | PLLDIV1 | PLLDIV0 | PLL96MHZ | FNOSC2 | FNOSC1 | FNOSC0 |
| bit 15 | | | | | | | bit 8 |

| | | | | | | | |
|--------|--------|----------|---------|----------|----------|---------|---------|
| R/PO-1 | R/PO-1 | R/PO-1 | R/PO-1 | r-1 | r-1 | R/PO-1 | R/PO-1 |
| FCKSM1 | FCKSM0 | OSCIOFCN | IOL1WAY | reserved | reserved | POSCMD1 | POSCMD0 |
| bit 7 | | | | | | | bit 0 |

| | | | |
|-------------------|------------------|------------------------------------|--------------------|
| Legend: | r = Reserved bit | | |
| R = Readable bit | W = Writable bit | U = Unimplemented bit, read as '0' | |
| -n = Value at POR | '1' = Bit is set | '0' = Bit is cleared | x = Bit is unknown |

bit 23-16 **Unimplemented:** Read as '1'

bit 15 **IESO:** Internal External Switchover bit
 1 = IESO mode (Two-Speed Start-up) is enabled
 0 = IESO mode (Two-Speed Start-up) is disabled

bit 14-12 **PLLDIV<2:0>:** 96 MHz PLL Prescaler Select bits
 111 = Oscillator input is divided by 12 (48 MHz input)
 110 = Oscillator input is divided by 8 (32 MHz input)
 101 = Oscillator input is divided by 6 (24 MHz input)
 100 = Oscillator input is divided by 5 (20 MHz input)
 011 = Oscillator input is divided by 4 (16 MHz input)
 010 = Oscillator input is divided by 3 (12 MHz input)
 001 = Oscillator input is divided by 2 (8 MHz input)
 000 = Oscillator input is used directly (4 MHz input)

bit 11 **PLL96MHZ:** 96 MHz PLL Start-Up Enable bit
 1 = 96 MHz PLL is enabled automatically on start-up
 0 = 96 MHz PLL is software controlled (can be enabled by setting the PLEN bit in CLKDIV<5>)

bit 10-8 **FNOSC<2:0>:** Initial Oscillator Select bits
 111 = Fast RC Oscillator with Postscaler (FRCDIV)
 110 = Reserved
 101 = Low-Power RC Oscillator (LPRC)
 100 = Secondary Oscillator (SOSC)
 011 = Primary Oscillator with PLL module (XTPLL, HSPLL, ECPLL)
 010 = Primary Oscillator (XT, HS, EC)
 001 = Fast RC Oscillator with Postscaler and PLL module (FRCPLL)
 000 = Fast RC Oscillator (FRC)

bit 7-6 **FCKSM<1:0>:** Clock Switching and Fail-Safe Clock Monitor Configuration bits
 1x = Clock switching and Fail-Safe Clock Monitor are disabled
 01 = Clock switching is enabled, Fail-Safe Clock Monitor is disabled
 00 = Clock switching is enabled, Fail-Safe Clock Monitor is enabled

bit 5 **OSCIOFCN:** OSCO Pin Configuration bit
If POSCMD<1:0> = 11 or 00:
 1 = OSCO/CLKO/RC15 functions as CLKO (Fosc/2)
 0 = OSCO/CLKO/RC15 functions as port I/O (RC15)
If POSCMD<1:0> = 10 or 01:
 OSCIOFCN has no effect on OSCO/CLKO/RC15.

PIC24FJ256DA210 FAMILY

[查询PIC24FJ256DA106供应商](#)

REGISTER 27-2: CW2: FLASH CONFIGURATION WORD 2 (CONTINUED)

- bit 4 **IOL1WAY:** IOLOCK One-Way Set Enable bit
 1 = The IOLOCK bit (OSCCON<6>) can be set once, provided the unlock sequence has been completed. Once set, the Peripheral Pin Select registers cannot be written to a second time.
 0 = The IOLOCK bit can be set and cleared as needed, provided the unlock sequence has been completed
- bit 3-2 **Reserved:** Always maintain as '1'
- bit 1-0 **POSCMD<1:0>:** Primary Oscillator Configuration bits
 11 = Primary oscillator is disabled
 10 = HS Oscillator mode is selected
 01 = XT Oscillator mode is selected
 00 = EC Oscillator mode is selected

REGISTER 27-3: CW3: FLASH CONFIGURATION WORD 3

| | | | | | | | |
|--------|-----|-----|-----|-----|-----|-----|--------|
| U-0 | U-0 | U-0 | U-0 | U-0 | U-0 | U-0 | U-0 |
| — | — | — | — | — | — | — | — |
| bit 23 | | | | | | | bit 16 |

| | | | | | | | |
|--------|--------|--------|-----------------------|---------|---------|----------|----------|
| R/PO-1 | R/PO-1 | R/PO-1 | R/PO-1 | R/PO-1 | R/PO-1 | R/PO-1 | R/PO-1 |
| WPEND | WPCFG | WPDIS | ALTPMP ⁽¹⁾ | WUTSEL1 | WUTSEL0 | SOSCSEL1 | SOSCSEL0 |
| bit 15 | | | | | | | bit 8 |

| | | | | | | | |
|--------|--------|--------|--------|--------|--------|--------|--------|
| R/PO-1 | R/PO-1 | R/PO-1 | R/PO-1 | R/PO-1 | R/PO-1 | R/PO-1 | R/PO-1 |
| WFPF7 | WFPF6 | WFPF5 | WFPF4 | WFPF3 | WFPF2 | WFPF1 | WFPF0 |
| bit 7 | | | | | | | bit 0 |

| | |
|-------------------|------------------------------------|
| Legend: | PO = Program-Once bit |
| R = Readable bit | W = Writable bit |
| -n = Value at POR | '1' = Bit is set |
| | U = Unimplemented bit, read as '0' |
| | '0' = Bit is cleared |
| | x = Bit is unknown |

- bit 23-16 **Unimplemented:** Read as '1'
- bit 15 **WPEND:** Segment Write Protection End Page Select bit
 1 = Protected code segment upper boundary is at the last page of program memory; the lower boundary is the code page specified by WFPF<7:0>
 0 = Protected code segment lower boundary is at the bottom of the program memory (000000h); upper boundary is the code page specified by WFPF<7:0>
- bit 14 **WPCFG:** Configuration Word Code Page Write Protection Select bit
 1 = Last page (at the top of program memory) and Flash Configuration Words are not write-protected⁽³⁾
 0 = Last page and Flash Configuration Words are write-protected, provided WPDIS = '0'
- bit 13 **WPDIS:** Segment Write Protection Disable bit
 1 = Segmented code protection is disabled
 0 = Segmented code protection is enabled; protected segment is defined by the WPEND, WPCFG and WFPFx Configuration bits
- bit 12 **ALTPMP:** Alternate EPMP Pin Mapping bit⁽¹⁾
 1 = EPMP pins are in default location mode
 0 = EPMP pins are in alternate location mode

- Note 1:** Unimplemented in 64-pin devices, maintain at '1'.
2: Ensure that the SCLKI pin is made a digital input while using this configuration, see Table 10-1.
3: Regardless of WPCFG status, if WPEND = 1 or if WFPF corresponds to the Configuration Word's page, the Configuration Word's page is protected.

PIC24FJ256DA210 FAMILY

[查询PIC24FJ256DA106供应商](#)

REGISTER 27-3: CW3: FLASH CONFIGURATION WORD 3 (CONTINUED)

- bit 11-10 **WUTSEL<1:0>**: Voltage Regulator Standby Mode Wake-up Time Select bits
 11 = Default regulator start-up time is used
 01 = Fast regulator start-up time is used
 x0 = Reserved; do not use
- bit 9-8 **SOSCSEL<1:0>**: SOSC Selection Configuration bits
 11 = Secondary oscillator is in Default (high drive strength) Oscillator mode
 10 = Reserved; do not use
 01 = Secondary oscillator is in Low-Power (low drive strength) Oscillator mode
 00 = External clock (SCLKI) or Digital I/O mode⁽²⁾
- bit 7-0 **WPFP<7:0>**: Write Protected Code Segment Boundary Page bits
 Designates the 512 instruction words page boundary of the protected code segment.
 If **WPEND = 1**:
 Specifies the lower page boundary of the code-protected segment; the last page being the last implemented page in the device.
 If **WPEND = 0**:
 Specifies the upper page boundary of the code-protected segment; Page 0 being the lower boundary.
- Note 1:** Unimplemented in 64-pin devices, maintain at '1'.
Note 2: Ensure that the SCLKI pin is made a digital input while using this configuration, see Table 10-1.
Note 3: Regardless of WPCFG status, if **WPEND = 1** or if **WPFP** corresponds to the Configuration Word's page, the Configuration Word's page is protected.

REGISTER 27-4: CW4: FLASH CONFIGURATION WORD 4

| | | | | | | | |
|--------|-----|-----|-----|-----|-----|-----|--------|
| U-0 | U-0 | U-0 | U-0 | U-0 | U-0 | U-0 | U-0 |
| — | — | — | — | — | — | — | — |
| bit 23 | | | | | | | bit 16 |

| | | | | | | | |
|----------|----------|----------|----------|----------|----------|----------|----------|
| r-1 | r-1 | r-1 | r-1 | r-1 | r-1 | r-1 | r-1 |
| reserved | reserved | reserved | reserved | reserved | reserved | reserved | reserved |
| bit 15 | | | | | | | bit 8 |

| | | | | | | | |
|----------|----------|----------|----------|----------|----------|----------|----------|
| r-1 | r-1 | r-1 | r-1 | r-1 | r-1 | r-1 | r-1 |
| reserved | reserved | reserved | reserved | reserved | reserved | reserved | reserved |
| bit 7 | | | | | | | bit 0 |

| | | | |
|-------------------|------------------|------------------------------------|--------------------|
| Legend: | r = Reserved bit | | |
| R = Readable bit | W = Writable bit | U = Unimplemented bit, read as '0' | |
| -n = Value at POR | '1' = Bit is set | '0' = Bit is cleared | x = Bit is unknown |

- bit 23-16 **Unimplemented:** Read as '0'
 bit 15-0 **Reserved:** Always maintain as '1'

PIC24FJ256DA210 FAMILY

[查询PIC24FJ256DA106供应商](#)

REGISTER 27-5: DEVID: DEVICE ID REGISTER

| | | | | | | | |
|--------|-----|-----|-----|-----|-----|--------|-----|
| U-0 | U-0 | U-0 | U-0 | U-0 | U-0 | U-0 | U-0 |
| — | — | — | — | — | — | — | — |
| bit 23 | | | | | | bit 16 | |

| | | | | | | | |
|--------|--------|--------|--------|--------|--------|--------|--------|
| R | R | R | R | R | R | R | R |
| FAMID7 | FAMID6 | FAMID5 | FAMID4 | FAMID3 | FAMID2 | FAMID1 | FAMID0 |
| bit 15 | | | | | | bit 8 | |

| | | | | | | | |
|-------|------|------|------|------|------|-------|------|
| R | R | R | R | R | R | R | R |
| DEV7 | DEV6 | DEV5 | DEV4 | DEV3 | DEV2 | DEV1 | DEV0 |
| bit 7 | | | | | | bit 0 | |

| | |
|---------------------------------|-----------------------|
| Legend: R = Readable bit | U = Unimplemented bit |
|---------------------------------|-----------------------|

bit 23-16 **Unimplemented:** Read as '1'

bit 15-8 **FAMID<7:0>:** Device Family Identifier bits
 01000001 = PIC24FJ256DA210 family

bit 7-0 **DEV<7:0>:** Individual Device Identifier bits
 00001000 = PIC24FJ128DA206
 00001001 = PIC24FJ128DA106
 00001010 = PIC24FJ128DA210
 00001011 = PIC24FJ128DA110
 00001100 = PIC24FJ256DA206
 00001101 = PIC24FJ256DA106
 00001110 = PIC24FJ256DA210
 00001111 = PIC24FJ256DA110

PIC24FJ256DA210 FAMILY

[查询PIC24FJ256DA106供应商](#)

REGISTER 27-6: DEVREV: DEVICE REVISION REGISTER

| | | | | | | | |
|--------|-----|-----|-----|--------|-----|-----|-----|
| U-0 | U-0 | U-0 | U-0 | U-0 | U-0 | U-0 | U-0 |
| — | — | — | — | — | — | — | — |
| bit 23 | | | | bit 16 | | | |

| | | | | | | | |
|--------|-----|-----|-----|-------|-----|-----|-----|
| U-0 | U-0 | U-0 | U-0 | U-0 | U-0 | U-0 | U-0 |
| — | — | — | — | — | — | — | — |
| bit 15 | | | | bit 8 | | | |

| | | | | | | | |
|-------|-----|-----|-----|-------|------|------|------|
| U-0 | U-0 | U-0 | U-0 | R | R | R | R |
| — | — | — | — | REV3 | REV2 | REV1 | REV0 |
| bit 7 | | | | bit 0 | | | |

Legend: R = Readable bit U = Unimplemented bit

- bit 23-4 **Unimplemented:** Read as '0'
- bit 3-0 **REV<3:0>:** Device revision identifier bits

27.2 On-Chip Voltage Regulator

All PIC24FJ256DA210 family devices power their core digital logic at a nominal 1.8V. This may create an issue for designs that are required to operate at a higher typical voltage, such as 3.3V. To simplify system design, all devices in the PIC24FJ256DA210 family incorporate an on-chip regulator that allows the device to run its core logic from VDD.

The regulator is controlled by the ENVREG pin. Tying VDD to the pin enables the regulator, which in turn, provides power to the core from the other VDD pins. When the regulator is enabled, a low-ESR capacitor (such as ceramic) must be connected to the VCAP pin (Figure 27-1). This helps to maintain the stability of the regulator. The recommended value for the filter capacitor (CEFC) is provided in **Section 30.1 “DC Characteristics”**.

27.2.1 VOLTAGE REGULATOR LOW-VOLTAGE DETECTION

When the on-chip regulator is enabled, it provides a constant voltage of 1.8V nominal to the digital core logic.

The regulator can provide this level from a VDD of about 2.1V, all the way up to the device's VDDMAX. It does not have the capability to boost VDD levels. In order to prevent “brown-out” conditions when the voltage drops too low for the regulator, the Brown-out Reset occurs. Then the regulator output follows VDD with a typical voltage drop of 300 mV.

To provide information about when the regulator voltage starts reducing, the on-chip regulator includes a simple Low-Voltage Detect circuit, which sets the

Low-Voltage Detect Interrupt Flag, LVDIF (IFS4<8>). This can be used to generate an interrupt to trigger an orderly shutdown.

FIGURE 27-1: CONNECTIONS FOR THE ON-CHIP REGULATOR

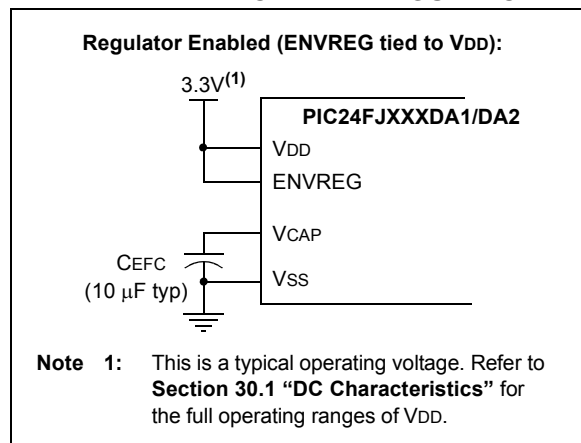

27.2.2 ON-CHIP REGULATOR AND POR

When the voltage regulator is enabled, it takes approximately 10 µs for it to generate output. During this time, designated as TVREG, code execution is disabled. TVREG is applied every time the device resumes operation after any power-down, including Sleep mode. TVREG is determined by the status of the VREGS bit (RCON<8>) and the WUTSEL Configuration bits (CW3<11:10>). Refer to **Section 30.0 “Electrical Characteristics”** for more information on TVREG.

PIC24FJ256DA210 FAMILY

[查询PIC24FJ256DA106供应商](#)

27.2.3 ON-CHIP REGULATOR AND BOR

When the on-chip regulator is enabled, PIC24FJ256DA210 family devices also have a simple brown-out capability. If the voltage supplied to the regulator is inadequate to maintain the output level, the regulator Reset circuitry will generate a Brown-out Reset. This event is captured by the BOR (RCON<1>) flag bit. The brown-out voltage specifications are provided in **Section 7. “Reset”** (DS39712) in the “PIC24F Family Reference Manual”.

Note: For more information, see **Section 30.0 “Electrical Characteristics”**. The information in this data sheet supersedes the information in the FRM.

27.2.4 VOLTAGE REGULATOR STANDBY MODE

When enabled, the on-chip regulator always consumes a small incremental amount of current over IDD/IPD, including when the device is in Sleep mode, even though the core digital logic does not require power. To provide additional savings in applications where power resources are critical, the regulator can be made to enter Standby mode on its own whenever the device goes into Sleep mode. This feature is controlled by the VREGS bit (RCON<8>). Clearing the VREGS bit enables the Standby mode. When waking up from Standby mode, the regulator needs to wait for TVREG to expire before wake-up.

The regulator wake-up time required for Standby mode is controlled by the WUTSEL<1:0> (CW3<11:10>) Configuration bits. The regulator wake-up time is lower when WUTSEL<1:0> = 01, and higher when WUTSEL<1:0> = 11. Refer to the TVREG specification in Table 30-10 for regulator wake-up time.

When the regulator’s Standby mode is turned off (VREGS = 1), the device wakes up without waiting for TVREG. However, with the VREGS bit set, the power consumption while in Sleep mode will be approximately 40 μ A higher than what it would be if the regulator was allowed to enter Standby mode.

27.3 Watchdog Timer (WDT)

For PIC24FJ256DA210 family devices, the WDT is driven by the LPRC oscillator. When the WDT is enabled, the clock source is also enabled.

The nominal WDT clock source from LPRC is 31 kHz. This feeds a prescaler that can be configured for either 5-bit (divide-by-32) or 7-bit (divide-by-128) operation. The prescaler is set by the FWPSA Configuration bit. With a 31 kHz input, the prescaler yields a nominal WDT Time-out period (TWDT) of 1 ms in 5-bit mode or 4 ms in 7-bit mode.

A variable postscaler divides down the WDT prescaler output and allows for a wide range of time-out periods. The postscaler is controlled by the WDTPS<3:0> Configuration bits (CW1<3:0>), which allows the selection of a total of 16 settings, from 1:1 to 1:32,768. Using the prescaler and postscaler time-out periods, ranging from 1 ms to 131 seconds, can be achieved.

The WDT, prescaler and postscaler are reset:

- On any device Reset
- On the completion of a clock switch, whether invoked by software (i.e., setting the OSWEN bit after changing the NOSC bits) or by hardware (i.e., Fail-Safe Clock Monitor)
- When a PWRSAV instruction is executed (i.e., Sleep or Idle mode is entered)
- When the device exits Sleep or Idle mode to resume normal operation
- By a CLRWDT instruction during normal execution

If the WDT is enabled, it will continue to run during Sleep or Idle modes. When the WDT time-out occurs, the device will wake the device and code execution will continue from where the PWRSAV instruction was executed. The corresponding SLEEP or IDLE (RCON<3:2>) bits will need to be cleared in software after the device wakes up.

The WDT Flag bit, WDTO (RCON<4>), is not automatically cleared following a WDT time-out. To detect subsequent WDT events, the flag must be cleared in software.

Note: The CLRWDT and PWRSAV instructions clear the prescaler and postscaler counts when executed.

PIC24FJ256DA210 FAMILY

[查询PIC24FJ256DA106供应商](#)

27.3.1 WINDOWED OPERATION

The Watchdog Timer has an optional Fixed-Window mode of operation. In this Windowed mode, `CLRWDT` instructions can only reset the WDT during the last 1/4 of the programmed WDT period. A `CLRWDT` instruction executed before that window causes a WDT Reset, similar to a WDT time-out.

Windowed WDT mode is enabled by programming the `WINDIS` Configuration bit (`CW1<6>`) to '0'.

27.3.2 CONTROL REGISTER

The WDT is enabled or disabled by the `FWDTEN` Configuration bit. When the `FWDTEN` Configuration bit is set, the WDT is always enabled.

The WDT can be optionally controlled in software when the `FWDTEN` Configuration bit has been programmed to '0'. The WDT is enabled in software by setting the `SWDTEN` Control bit (`RCON<5>`). The `SWDTEN` control bit is cleared on any device Reset. The software WDT option allows the user to enable the WDT for critical code segments and disable the WDT during non-critical segments for maximum power savings.

FIGURE 27-2: WDT BLOCK DIAGRAM

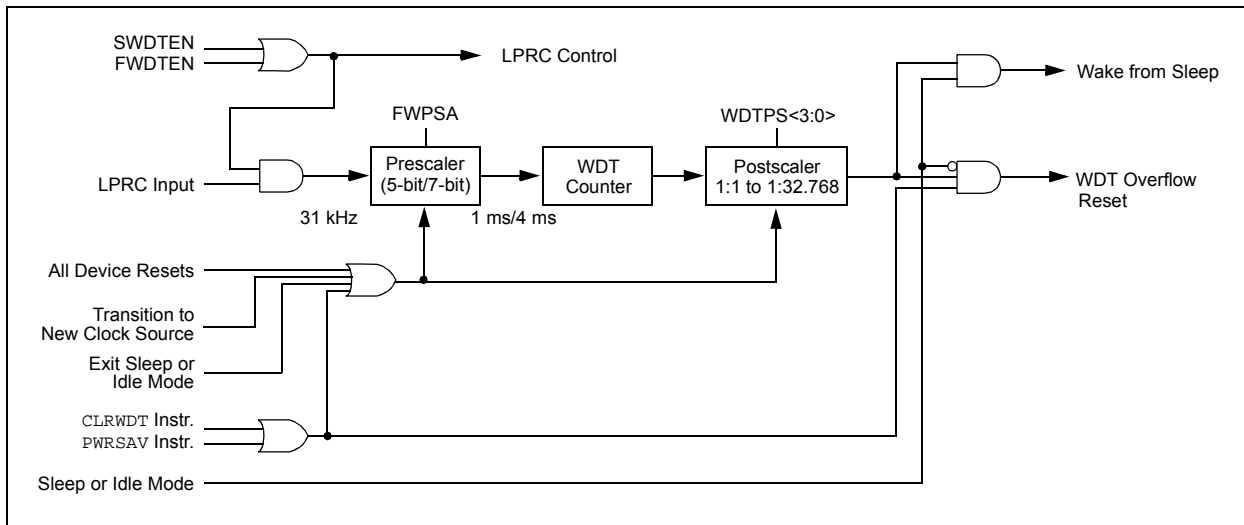

27.4 Program Verification and Code Protection

PIC24FJ256DA210 family devices provide two complimentary methods to protect application code from overwrites and erasures. These also help to protect the device from inadvertent configuration changes during run time.

27.4.1 GENERAL SEGMENT PROTECTION

For all devices in the PIC24FJ256DA210 family, the on-chip program memory space is treated as a single block, known as the General Segment (GS). Code protection for this block is controlled by one Configuration bit, GCP. This bit inhibits external reads and writes to the program memory space. It has no direct effect in normal execution mode.

Write protection is controlled by the GWRP bit in the Configuration Word. When GWRP is programmed to '0', internal write and erase operations to program memory are blocked.

27.4.2 CODE SEGMENT PROTECTION

In addition to global General Segment protection, a separate subrange of the program memory space can be individually protected against writes and erases. This area can be used for many purposes where a separate block of write and erase-protected code is needed, such as bootloader applications. Unlike common boot block implementations, the specially protected segment in the PIC24FJ256DA210 family devices can be located by the user anywhere in the program space and configured in a wide range of sizes.

Code segment protection provides an added level of protection to a designated area of program memory by disabling the NVM safety interlock whenever a write or erase address falls within a specified range. It does not override General Segment protection controlled by the GCP or GWRP bits. For example, if GCP and GWRP are enabled, enabling segmented code protection for the bottom half of program memory does not undo General Segment protection for the top half.

The size and type of protection for the segmented code range are configured by the WFPFx, WPEND, WPCFG and WPDIS bits in Configuration Word 3. Code segment protection is enabled by programming the WPDIS bit (= 0). The WFPF bits specify the size of the segment to be protected, by specifying the 512-word code page that is the start or end of the protected segment. The specified region is inclusive, therefore, this page will also be protected.

The WPEND bit determines if the protected segment uses the top or bottom of the program space as a boundary. Programming WPEND (= 0) sets the bottom of program memory (000000h) as the lower boundary of the protected segment. Leaving WPEND unprogrammed (= 1) protects the specified page through the last page of implemented program memory, including the Configuration Word locations.

A separate bit, WPCFG, is used to protect the last page of program space, including the Flash Configuration Words. Programming WPCFG (= 0) protects the last page in addition to the pages selected by the WPEND and WFPF<7:0> bits setting. This is useful in circumstances where write protection is needed for both the code segment in the bottom of the memory and the Flash Configuration Words.

The various options for segment code protection are shown in Table 27-2.

PIC24FJ256DA210 FAMILY

[查询PIC24FJ256DA106供应商](#)

27.4.3 CONFIGURATION REGISTER PROTECTION

The Configuration registers are protected against inadvertent or unwanted changes or reads in two ways. The primary protection method is the same as that of the RP registers – shadow registers contain a complimentary value which is constantly compared with the actual value.

To safeguard against unpredictable events, Configuration bit changes resulting from individual cell level disruptions (such as ESD events) will cause a parity error and trigger a device Reset.

The data for the Configuration registers is derived from the Flash Configuration Words in program memory. When the GCP bit is set, the source data for device configuration is also protected as a consequence. Even if General Segment protection is not enabled, the device configuration can be protected by using the appropriate code segment protection setting.

TABLE 27-2: CODE SEGMENT PROTECTION CONFIGURATION OPTIONS

| Segment Configuration Bits | | | Write/Erase Protection of Code Segment |
|----------------------------|-------|-------|--|
| WPDIS | WPEND | WPCFG | |
| 1 | X | x | No additional protection is enabled; all program memory protection is configured by GCP and GWRP. |
| 0 | 1 | x | Addresses from the first address of the code page are defined by WPPF<7:0> through the end of implemented program memory (inclusive), write/erase protected, including Flash Configuration Words. |
| 0 | 0 | 1 | Address 000000h through the last address of the code page is defined by WPPF<7:0> (inclusive), write/erase protected. |
| 0 | 0 | 0 | Address 000000h through the last address of code page is defined by WPPF<7:0> (inclusive), write/erase protected and the last page, including Flash Configuration Words are write/erase protected. |

27.5 JTAG Interface

PIC24FJ256DA210 family devices implement a JTAG interface, which supports boundary scan device testing.

27.6 In-Circuit Serial Programming™

PIC24FJ256DA210 family microcontrollers can be serially programmed while in the end application circuit. This is simply done with two lines for clock (PGECx) and data (PGEDx), and three other lines for power (VDD), ground (VSS) and MCLR. This allows customers to manufacture boards with unprogrammed devices and then program the microcontroller just before shipping the product. This also allows the most recent firmware or a custom firmware to be programmed.

27.7 In-Circuit Debugger

When MPLAB® ICD 3 is selected as a debugger, the in-circuit debugging functionality is enabled. This function allows simple debugging functions when used with MPLAB IDE. Debugging functionality is controlled through the PGECx (Emulation/Debug Clock) and PGEDx (Emulation/Debug Data) pins.

To use the in-circuit debugger function of the device, the design must implement ICSP connections to MCLR, VDD, VSS and the PGECx/PGEDx pin pair designated by the ICS Configuration bits. In addition, when the feature is enabled, some of the resources are not available for general use. These resources include the first 80 bytes of data RAM and two I/O pins.

PIC24FJ256DA210 FAMILY

[查询PIC24FJ256DA106供应商](#)

28.0 DEVELOPMENT SUPPORT

The PIC[®] microcontrollers and dsPIC[®] digital signal controllers are supported with a full range of software and hardware development tools:

- Integrated Development Environment
 - MPLAB[®] IDE Software
- Compilers/Assemblers/Linkers
 - MPLAB C Compiler for Various Device Families
 - HI-TECH C for Various Device Families
 - MPASM[™] Assembler
 - MPLINK[™] Object Linker/
MPLIB[™] Object Librarian
 - MPLAB Assembler/Linker/Librarian for Various Device Families
- Simulators
 - MPLAB SIM Software Simulator
- Emulators
 - MPLAB REAL ICE[™] In-Circuit Emulator
- In-Circuit Debuggers
 - MPLAB ICD 3
 - PICKit[™] 3 Debug Express
- Device Programmers
 - PICKit[™] 2 Programmer
 - MPLAB PM3 Device Programmer
- Low-Cost Demonstration/Development Boards, Evaluation Kits, and Starter Kits

28.1 MPLAB Integrated Development Environment Software

The MPLAB IDE software brings an ease of software development previously unseen in the 8/16/32-bit microcontroller market. The MPLAB IDE is a Windows[®] operating system-based application that contains:

- A single graphical interface to all debugging tools
 - Simulator
 - Programmer (sold separately)
 - In-Circuit Emulator (sold separately)
 - In-Circuit Debugger (sold separately)
- A full-featured editor with color-coded context
- A multiple project manager
- Customizable data windows with direct edit of contents
- High-level source code debugging
- Mouse over variable inspection
- Drag and drop variables from source to watch windows
- Extensive on-line help
- Integration of select third party tools, such as IAR C Compilers

The MPLAB IDE allows you to:

- Edit your source files (either C or assembly)
- One-touch compile or assemble, and download to emulator and simulator tools (automatically updates all project information)
- Debug using:
 - Source files (C or assembly)
 - Mixed C and assembly
 - Machine code

MPLAB IDE supports multiple debugging tools in a single development paradigm, from the cost-effective simulators, through low-cost in-circuit debuggers, to full-featured emulators. This eliminates the learning curve when upgrading to tools with increased flexibility and power.

PIC24FJ256DA210 FAMILY

[查询PIC24FJ256DA106供应商](#)

28.2 MPLAB C Compilers for Various Device Families

The MPLAB C Compiler code development systems are complete ANSI C compilers for Microchip's PIC18, PIC24 and PIC32 families of microcontrollers and the dsPIC30 and dsPIC33 families of digital signal controllers. These compilers provide powerful integration capabilities, superior code optimization and ease of use.

For easy source level debugging, the compilers provide symbol information that is optimized to the MPLAB IDE debugger.

28.3 HI-TECH C for Various Device Families

The HI-TECH C Compiler code development systems are complete ANSI C compilers for Microchip's PIC family of microcontrollers and the dsPIC family of digital signal controllers. These compilers provide powerful integration capabilities, omniscient code generation and ease of use.

For easy source level debugging, the compilers provide symbol information that is optimized to the MPLAB IDE debugger.

The compilers include a macro assembler, linker, pre-processor, and one-step driver, and can run on multiple platforms.

28.4 MPASM Assembler

The MPASM Assembler is a full-featured, universal macro assembler for PIC10/12/16/18 MCUs.

The MPASM Assembler generates relocatable object files for the MPLINK Object Linker, Intel® standard HEX files, MAP files to detail memory usage and symbol reference, absolute LST files that contain source lines and generated machine code and COFF files for debugging.

The MPASM Assembler features include:

- Integration into MPLAB IDE projects
- User-defined macros to streamline assembly code
- Conditional assembly for multi-purpose source files
- Directives that allow complete control over the assembly process

28.5 MPLINK Object Linker/ MPLIB Object Librarian

The MPLINK Object Linker combines relocatable objects created by the MPASM Assembler and the MPLAB C18 C Compiler. It can link relocatable objects from precompiled libraries, using directives from a linker script.

The MPLIB Object Librarian manages the creation and modification of library files of precompiled code. When a routine from a library is called from a source file, only the modules that contain that routine will be linked in with the application. This allows large libraries to be used efficiently in many different applications.

The object linker/library features include:

- Efficient linking of single libraries instead of many smaller files
- Enhanced code maintainability by grouping related modules together
- Flexible creation of libraries with easy module listing, replacement, deletion and extraction

28.6 MPLAB Assembler, Linker and Librarian for Various Device Families

MPLAB Assembler produces relocatable machine code from symbolic assembly language for PIC24, PIC32 and dsPIC devices. MPLAB C Compiler uses the assembler to produce its object file. The assembler generates relocatable object files that can then be archived or linked with other relocatable object files and archives to create an executable file. Notable features of the assembler include:

- Support for the entire device instruction set
- Support for fixed-point and floating-point data
- Command line interface
- Rich directive set
- Flexible macro language
- MPLAB IDE compatibility

PIC24FJ256DA210 FAMILY

[查询PIC24FJ256DA106供应商](#)

28.7 MPLAB SIM Software Simulator

The MPLAB SIM Software Simulator allows code development in a PC-hosted environment by simulating the PIC MCUs and dsPIC® DSCs on an instruction level. On any given instruction, the data areas can be examined or modified and stimuli can be applied from a comprehensive stimulus controller. Registers can be logged to files for further run-time analysis. The trace buffer and logic analyzer display extend the power of the simulator to record and track program execution, actions on I/O, most peripherals and internal registers.

The MPLAB SIM Software Simulator fully supports symbolic debugging using the MPLAB C Compilers, and the MPASM and MPLAB Assemblers. The software simulator offers the flexibility to develop and debug code outside of the hardware laboratory environment, making it an excellent, economical software development tool.

28.8 MPLAB REAL ICE In-Circuit Emulator System

MPLAB REAL ICE In-Circuit Emulator System is Microchip's next generation high-speed emulator for Microchip Flash DSC and MCU devices. It debugs and programs PIC® Flash MCUs and dsPIC® Flash DSCs with the easy-to-use, powerful graphical user interface of the MPLAB Integrated Development Environment (IDE), included with each kit.

The emulator is connected to the design engineer's PC using a high-speed USB 2.0 interface and is connected to the target with either a connector compatible with in-circuit debugger systems (RJ11) or with the new high-speed, noise tolerant, Low-Voltage Differential Signal (LVDS) interconnection (CAT5).

The emulator is field upgradable through future firmware downloads in MPLAB IDE. In upcoming releases of MPLAB IDE, new devices will be supported, and new features will be added. MPLAB REAL ICE offers significant advantages over competitive emulators including low-cost, full-speed emulation, run-time variable watches, trace analysis, complex breakpoints, a ruggedized probe interface and long (up to three meters) interconnection cables.

28.9 MPLAB ICD 3 In-Circuit Debugger System

MPLAB ICD 3 In-Circuit Debugger System is Microchip's most cost effective high-speed hardware debugger/programmer for Microchip Flash Digital Signal Controller (DSC) and microcontroller (MCU) devices. It debugs and programs PIC® Flash microcontrollers and dsPIC® DSCs with the powerful, yet easy-to-use graphical user interface of MPLAB Integrated Development Environment (IDE).

The MPLAB ICD 3 In-Circuit Debugger probe is connected to the design engineer's PC using a high-speed USB 2.0 interface and is connected to the target with a connector compatible with the MPLAB ICD 2 or MPLAB REAL ICE systems (RJ-11). MPLAB ICD 3 supports all MPLAB ICD 2 headers.

28.10 PICkit 3 In-Circuit Debugger/Programmer and PICkit 3 Debug Express

The MPLAB PICkit 3 allows debugging and programming of PIC® and dsPIC® Flash microcontrollers at a most affordable price point using the powerful graphical user interface of the MPLAB Integrated Development Environment (IDE). The MPLAB PICkit 3 is connected to the design engineer's PC using a full speed USB interface and can be connected to the target via an Microchip debug (RJ-11) connector (compatible with MPLAB ICD 3 and MPLAB REAL ICE). The connector uses two device I/O pins and the reset line to implement in-circuit debugging and In-Circuit Serial Programming™.

The PICkit 3 Debug Express include the PICkit 3, demo board and microcontroller, hookup cables and CDROM with user's guide, lessons, tutorial, compiler and MPLAB IDE software.

PIC24FJ256DA210 FAMILY

[查询PIC24FJ256DA106供应商](#)

28.11 PICKit 2 Development Programmer/Debugger and PICKit 2 Debug Express

The PICKit™ 2 Development Programmer/Debugger is a low-cost development tool with an easy to use interface for programming and debugging Microchip's Flash families of microcontrollers. The full featured Windows® programming interface supports baseline (PIC10F, PIC12F5xx, PIC16F5xx), midrange (PIC12F6xx, PIC16F), PIC18F, PIC24, dsPIC30, dsPIC33, and PIC32 families of 8-bit, 16-bit, and 32-bit microcontrollers, and many Microchip Serial EEPROM products. With Microchip's powerful MPLAB Integrated Development Environment (IDE) the PICKit™ 2 enables in-circuit debugging on most PIC® microcontrollers. In-Circuit-Debugging runs, halts and single steps the program while the PIC microcontroller is embedded in the application. When halted at a breakpoint, the file registers can be examined and modified.

The PICKit 2 Debug Express include the PICKit 2, demo board and microcontroller, hookup cables and CDROM with user's guide, lessons, tutorial, compiler and MPLAB IDE software.

28.12 MPLAB PM3 Device Programmer

The MPLAB PM3 Device Programmer is a universal, CE compliant device programmer with programmable voltage verification at VDDMIN and VDDMAX for maximum reliability. It features a large LCD display (128 x 64) for menus and error messages and a modular, detachable socket assembly to support various package types. The ICSP™ cable assembly is included as a standard item. In Stand-Alone mode, the MPLAB PM3 Device Programmer can read, verify and program PIC devices without a PC connection. It can also set code protection in this mode. The MPLAB PM3 connects to the host PC via an RS-232 or USB cable. The MPLAB PM3 has high-speed communications and optimized algorithms for quick programming of large memory devices and incorporates an MMC card for file storage and data applications.

28.13 Demonstration/Development Boards, Evaluation Kits, and Starter Kits

A wide variety of demonstration, development and evaluation boards for various PIC MCUs and dsPIC DSCs allows quick application development on fully functional systems. Most boards include prototyping areas for adding custom circuitry and provide application firmware and source code for examination and modification.

The boards support a variety of features, including LEDs, temperature sensors, switches, speakers, RS-232 interfaces, LCD displays, potentiometers and additional EEPROM memory.

The demonstration and development boards can be used in teaching environments, for prototyping custom circuits and for learning about various microcontroller applications.

In addition to the PICDEM™ and dsPICDEM™ demonstration/development board series of circuits, Microchip has a line of evaluation kits and demonstration software for analog filter design, KEELOQ® security ICs, CAN, IrDA®, PowerSmart battery management, SEEVAL® evaluation system, Sigma-Delta ADC, flow rate sensing, plus many more.

Also available are starter kits that contain everything needed to experience the specified device. This usually includes a single application and debug capability, all on one board.

Check the Microchip web page (www.microchip.com) for the complete list of demonstration, development and evaluation kits.

PIC24FJ256DA210 FAMILY

[查询PIC24FJ256DA106供应商](#)

29.0 INSTRUCTION SET SUMMARY

Note: This chapter is a brief summary of the PIC24F instruction set architecture and is not intended to be a comprehensive reference source.

The PIC24F instruction set adds many enhancements to the previous PIC[®] MCU instruction sets, while maintaining an easy migration from previous PIC MCU instruction sets. Most instructions are a single program memory word. Only three instructions require two program memory locations.

Each single-word instruction is a 24-bit word divided into an 8-bit opcode, which specifies the instruction type and one or more operands, which further specify the operation of the instruction. The instruction set is highly orthogonal and is grouped into four basic categories:

- Word or byte-oriented operations
- Bit-oriented operations
- Literal operations
- Control operations

Table 29-1 shows the general symbols used in describing the instructions. The PIC24F instruction set summary in Table 29-2 lists all the instructions, along with the status flags affected by each instruction.

Most word or byte-oriented W register instructions (including barrel shift instructions) have three operands:

- The first source operand which is typically a register 'Wb' without any address modifier
- The second source operand which is typically a register 'Ws' with or without an address modifier
- The destination of the result which is typically a register 'Wd' with or without an address modifier

However, word or byte-oriented file register instructions have two operands:

- The file register specified by the value 'f'
- The destination, which could either be the file register 'f' or the W0 register, which is denoted as 'WREG'

Most bit-oriented instructions (including simple rotate/shift instructions) have two operands:

- The W register (with or without an address modifier) or file register (specified by the value of 'Ws' or 'f')
- The bit in the W register or file register (specified by a literal value or indirectly by the contents of register 'Wb')

The literal instructions that involve data movement may use some of the following operands:

- A literal value to be loaded into a W register or file register (specified by the value of 'k')
- The W register or file register where the literal value is to be loaded (specified by 'Wb' or 'f')

However, literal instructions that involve arithmetic or logical operations use some of the following operands:

- The first source operand which is a register 'Wb' without any address modifier
- The second source operand which is a literal value
- The destination of the result (only if not the same as the first source operand), which is typically a register 'Wd' with or without an address modifier

The control instructions may use some of the following operands:

- A program memory address
- The mode of the table read and table write instructions

All instructions are a single word, except for certain double-word instructions, which were made double-word instructions so that all the required information is available in these 48 bits. In the second word, the 8 MSBs are '0's. If this second word is executed as an instruction (by itself), it will execute as a NOP.

Most single-word instructions are executed in a single instruction cycle, unless a conditional test is true or the program counter is changed as a result of the instruction. In these cases, the execution takes two instruction cycles, with the additional instruction cycle(s) executed as a NOP. Notable exceptions are the BRA (unconditional/computed branch), indirect CALL/GOTO, all table reads and writes, and RETURN/RETFIE instructions, which are single-word instructions but take two or three cycles.

Certain instructions that involve skipping over the subsequent instruction require either two or three cycles if the skip is performed, depending on whether the instruction being skipped is a single-word or two-word instruction. Moreover, double-word moves require two cycles. The double-word instructions execute in two instruction cycles.

PIC24FJ256DA210 FAMILY

[查询PIC24FJ256DA106供应商](#)

TABLE 29-1: SYMBOLS USED IN OPCODE DESCRIPTIONS

| Field | Description |
|-----------------|---|
| #text | Means literal defined by "text" |
| (text) | Means "content of text" |
| [text] | Means "the location addressed by text" |
| { } | Optional field or operation |
| <n:m> | Register bit field |
| .b | Byte mode selection |
| .d | Double-Word mode selection |
| .S | Shadow register select |
| .w | Word mode selection (default) |
| bit4 | 4-bit Bit Selection field (used in word addressed instructions) $\in \{0...15\}$ |
| C, DC, N, OV, Z | MCU Status bits: Carry, Digit Carry, Negative, Overflow, Sticky Zero |
| Expr | Absolute address, label or expression (resolved by the linker) |
| f | File register address $\in \{0000h...1FFFh\}$ |
| lit1 | 1-bit unsigned literal $\in \{0,1\}$ |
| lit4 | 4-bit unsigned literal $\in \{0...15\}$ |
| lit5 | 5-bit unsigned literal $\in \{0...31\}$ |
| lit8 | 8-bit unsigned literal $\in \{0...255\}$ |
| lit10 | 10-bit unsigned literal $\in \{0...255\}$ for Byte mode, $\{0:1023\}$ for Word mode |
| lit14 | 14-bit unsigned literal $\in \{0...16383\}$ |
| lit16 | 16-bit unsigned literal $\in \{0...65535\}$ |
| lit23 | 23-bit unsigned literal $\in \{0...8388607\}$; LSB must be '0' |
| None | Field does not require an entry, may be blank |
| PC | Program Counter |
| Slit10 | 10-bit signed literal $\in \{-512...511\}$ |
| Slit16 | 16-bit signed literal $\in \{-32768...32767\}$ |
| Slit6 | 6-bit signed literal $\in \{-16...16\}$ |
| Wb | Base W register $\in \{W0..W15\}$ |
| Wd | Destination W register $\in \{Wd, [Wd], [Wd++] , [Wd--], [++Wd], [--Wd] \}$ |
| Wdo | Destination W register $\in \{Wnd, [Wnd], [Wnd++] , [Wnd--], [++Wnd], [--Wnd], [Wnd+Wb] \}$ |
| Wm,Wn | Dividend, Divisor working register pair (direct addressing) |
| Wn | One of 16 working registers $\in \{W0..W15\}$ |
| Wnd | One of 16 destination working registers $\in \{W0..W15\}$ |
| Wns | One of 16 source working registers $\in \{W0..W15\}$ |
| WREG | W0 (working register used in file register instructions) |
| Ws | Source W register $\in \{Ws, [Ws], [Ws++] , [Ws--], [++Ws], [--Ws] \}$ |
| Wso | Source W register $\in \{Wns, [Wns], [Wns++] , [Wns--], [++Wns], [--Wns], [Wns+Wb] \}$ |

PIC24FJ256DA210 FAMILY

[查询PIC24FJ256DA106供应商](#)

TABLE 29-2: INSTRUCTION SET OVERVIEW

| Assembly Mnemonic | Assembly Syntax | Description | # of Words | # of Cycles | Status Flags Affected |
|-------------------|--------------------|--|------------|---------------|-----------------------|
| ADD | ADD f | $f = f + WREG$ | 1 | 1 | C, DC, N, OV, Z |
| | ADD f, WREG | $WREG = f + WREG$ | 1 | 1 | C, DC, N, OV, Z |
| | ADD #lit10, Wn | $Wd = lit10 + Wd$ | 1 | 1 | C, DC, N, OV, Z |
| | ADD Wb, Ws, Wd | $Wd = Wb + Ws$ | 1 | 1 | C, DC, N, OV, Z |
| | ADD Wb, #lit5, Wd | $Wd = Wb + lit5$ | 1 | 1 | C, DC, N, OV, Z |
| ADDC | ADDC f | $f = f + WREG + (C)$ | 1 | 1 | C, DC, N, OV, Z |
| | ADDC f, WREG | $WREG = f + WREG + (C)$ | 1 | 1 | C, DC, N, OV, Z |
| | ADDC #lit10, Wn | $Wd = lit10 + Wd + (C)$ | 1 | 1 | C, DC, N, OV, Z |
| | ADDC Wb, Ws, Wd | $Wd = Wb + Ws + (C)$ | 1 | 1 | C, DC, N, OV, Z |
| | ADDC Wb, #lit5, Wd | $Wd = Wb + lit5 + (C)$ | 1 | 1 | C, DC, N, OV, Z |
| AND | AND f | $f = f .AND. WREG$ | 1 | 1 | N, Z |
| | AND f, WREG | $WREG = f .AND. WREG$ | 1 | 1 | N, Z |
| | AND #lit10, Wn | $Wd = lit10 .AND. Wd$ | 1 | 1 | N, Z |
| | AND Wb, Ws, Wd | $Wd = Wb .AND. Ws$ | 1 | 1 | N, Z |
| | AND Wb, #lit5, Wd | $Wd = Wb .AND. lit5$ | 1 | 1 | N, Z |
| ASR | ASR f | f = Arithmetic Right Shift f | 1 | 1 | C, N, OV, Z |
| | ASR f, WREG | WREG = Arithmetic Right Shift f | 1 | 1 | C, N, OV, Z |
| | ASR Ws, Wd | Wd = Arithmetic Right Shift Ws | 1 | 1 | C, N, OV, Z |
| | ASR Wb, Wns, Wnd | Wnd = Arithmetic Right Shift Wb by Wns | 1 | 1 | N, Z |
| | ASR Wb, #lit5, Wnd | Wnd = Arithmetic Right Shift Wb by lit5 | 1 | 1 | N, Z |
| BCLR | BCLR f, #bit4 | Bit Clear f | 1 | 1 | None |
| | BCLR Ws, #bit4 | Bit Clear Ws | 1 | 1 | None |
| BRA | BRA C, Expr | Branch if Carry | 1 | 1 (2) | None |
| | BRA GE, Expr | Branch if Greater than or Equal | 1 | 1 (2) | None |
| | BRA GEU, Expr | Branch if Unsigned Greater than or Equal | 1 | 1 (2) | None |
| | BRA GT, Expr | Branch if Greater than | 1 | 1 (2) | None |
| | BRA GTU, Expr | Branch if Unsigned Greater than | 1 | 1 (2) | None |
| | BRA LE, Expr | Branch if Less than or Equal | 1 | 1 (2) | None |
| | BRA LEU, Expr | Branch if Unsigned Less than or Equal | 1 | 1 (2) | None |
| | BRA LT, Expr | Branch if Less than | 1 | 1 (2) | None |
| | BRA LTU, Expr | Branch if Unsigned Less than | 1 | 1 (2) | None |
| | BRA N, Expr | Branch if Negative | 1 | 1 (2) | None |
| | BRA NC, Expr | Branch if Not Carry | 1 | 1 (2) | None |
| | BRA NN, Expr | Branch if Not Negative | 1 | 1 (2) | None |
| | BRA NOV, Expr | Branch if Not Overflow | 1 | 1 (2) | None |
| | BRA NZ, Expr | Branch if Not Zero | 1 | 1 (2) | None |
| | BRA OV, Expr | Branch if Overflow | 1 | 1 (2) | None |
| | BRA Expr | Branch Unconditionally | 1 | 2 | None |
| | BRA Z, Expr | Branch if Zero | 1 | 1 (2) | None |
| BRA Wn | Computed Branch | 1 | 2 | None | |
| BSET | BSET f, #bit4 | Bit Set f | 1 | 1 | None |
| | BSET Ws, #bit4 | Bit Set Ws | 1 | 1 | None |
| BSW | BSW.C Ws, Wb | Write C bit to Ws<Wb> | 1 | 1 | None |
| | BSW.Z Ws, Wb | Write Z bit to Ws<Wb> | 1 | 1 | None |
| BTG | BTG f, #bit4 | Bit Toggle f | 1 | 1 | None |
| | BTG Ws, #bit4 | Bit Toggle Ws | 1 | 1 | None |
| BTSC | BTSC f, #bit4 | Bit Test f, Skip if Clear | 1 | 1 (2 or 3) | None |
| | BTSC Ws, #bit4 | Bit Test Ws, Skip if Clear | 1 | 1 (2 or 3) | None |

PIC24FJ256DA210 FAMILY

[查询PIC24FJ256DA106供应商](#)

TABLE 29-2: INSTRUCTION SET OVERVIEW (CONTINUED)

| Assembly Mnemonic | Assembly Syntax | Description | # of Words | # of Cycles | Status Flags Affected |
|-------------------|----------------------|--|------------|---------------|-----------------------|
| BTSS | BTSS $f, \#bit4$ | Bit Test f , Skip if Set | 1 | 1 (2 or 3) | None |
| | BTSS $Ws, \#bit4$ | Bit Test Ws , Skip if Set | 1 | 1 (2 or 3) | None |
| BTST | BTST $f, \#bit4$ | Bit Test f | 1 | 1 | Z |
| | BTST.C $Ws, \#bit4$ | Bit Test Ws to C | 1 | 1 | C |
| | BTST.Z $Ws, \#bit4$ | Bit Test Ws to Z | 1 | 1 | Z |
| | BTST.C Ws, Wb | Bit Test $Ws < Wb >$ to C | 1 | 1 | C |
| | BTST.Z Ws, Wb | Bit Test $Ws < Wb >$ to Z | 1 | 1 | Z |
| BTSTS | BTSTS $f, \#bit4$ | Bit Test then Set f | 1 | 1 | Z |
| | BTSTS.C $Ws, \#bit4$ | Bit Test Ws to C, then Set | 1 | 1 | C |
| | BTSTS.Z $Ws, \#bit4$ | Bit Test Ws to Z, then Set | 1 | 1 | Z |
| CALL | CALL $lit23$ | Call Subroutine | 2 | 2 | None |
| | CALL Wn | Call Indirect Subroutine | 1 | 2 | None |
| CLR | CLR f | $f = 0x0000$ | 1 | 1 | None |
| | CLR $WREG$ | $WREG = 0x0000$ | 1 | 1 | None |
| | CLR Ws | $Ws = 0x0000$ | 1 | 1 | None |
| CLRWDT | CLRWDT | Clear Watchdog Timer | 1 | 1 | WDTO, Sleep |
| COM | COM f | $f = \bar{f}$ | 1 | 1 | N, Z |
| | COM $f, WREG$ | $WREG = \bar{f}$ | 1 | 1 | N, Z |
| | COM Ws, Wd | $Wd = \bar{Ws}$ | 1 | 1 | N, Z |
| CP | CP f | Compare f with $WREG$ | 1 | 1 | C, DC, N, OV, Z |
| | CP $Wb, \#lit5$ | Compare Wb with $lit5$ | 1 | 1 | C, DC, N, OV, Z |
| | CP Wb, Ws | Compare Wb with Ws ($Wb - Ws$) | 1 | 1 | C, DC, N, OV, Z |
| CP0 | CP0 f | Compare f with $0x0000$ | 1 | 1 | C, DC, N, OV, Z |
| | CP0 Ws | Compare Ws with $0x0000$ | 1 | 1 | C, DC, N, OV, Z |
| CPB | CPB f | Compare f with $WREG$, with Borrow | 1 | 1 | C, DC, N, OV, Z |
| | CPB $Wb, \#lit5$ | Compare Wb with $lit5$, with Borrow | 1 | 1 | C, DC, N, OV, Z |
| | CPB Wb, Ws | Compare Wb with Ws , with Borrow ($Wb - Ws - C$) | 1 | 1 | C, DC, N, OV, Z |
| CPSEQ | CPSEQ Wb, Wn | Compare Wb with Wn , Skip if = | 1 | 1 (2 or 3) | None |
| CPSGT | CPSGT Wb, Wn | Compare Wb with Wn , Skip if > | 1 | 1 (2 or 3) | None |
| CPSLT | CPSLT Wb, Wn | Compare Wb with Wn , Skip if < | 1 | 1 (2 or 3) | None |
| CPSNE | CPSNE Wb, Wn | Compare Wb with Wn , Skip if \neq | 1 | 1 (2 or 3) | None |
| DAW | DAW.B Wn | $Wn =$ Decimal Adjust Wn | 1 | 1 | C |
| DEC | DEC f | $f = f - 1$ | 1 | 1 | C, DC, N, OV, Z |
| | DEC $f, WREG$ | $WREG = f - 1$ | 1 | 1 | C, DC, N, OV, Z |
| | DEC Ws, Wd | $Wd = Ws - 1$ | 1 | 1 | C, DC, N, OV, Z |
| DEC2 | DEC2 f | $f = f - 2$ | 1 | 1 | C, DC, N, OV, Z |
| | DEC2 $f, WREG$ | $WREG = f - 2$ | 1 | 1 | C, DC, N, OV, Z |
| | DEC2 Ws, Wd | $Wd = Ws - 2$ | 1 | 1 | C, DC, N, OV, Z |
| DISI | DISI $\#lit14$ | Disable Interrupts for k Instruction Cycles | 1 | 1 | None |
| DIV | DIV.SW Wm, Wn | Signed 16/16-bit Integer Divide | 1 | 18 | N, Z, C, OV |
| | DIV.SD Wm, Wn | Signed 32/16-bit Integer Divide | 1 | 18 | N, Z, C, OV |
| | DIV.UW Wm, Wn | Unsigned 16/16-bit Integer Divide | 1 | 18 | N, Z, C, OV |
| | DIV.UD Wm, Wn | Unsigned 32/16-bit Integer Divide | 1 | 18 | N, Z, C, OV |
| EXCH | EXCH Wns, Wnd | Swap Wns with Wnd | 1 | 1 | None |
| FF1L | FF1L Ws, Wnd | Find First One from Left (MSb) Side | 1 | 1 | C |
| FF1R | FF1R Ws, Wnd | Find First One from Right (LSb) Side | 1 | 1 | C |

PIC24FJ256DA210 FAMILY

[查询PIC24FJ256DA106供应商](#)

TABLE 29-2: INSTRUCTION SET OVERVIEW (CONTINUED)

| Assembly Mnemonic | Assembly Syntax | Description | # of Words | # of Cycles | Status Flags Affected |
|-------------------|-----------------------|--|------------|-------------|-----------------------|
| GOTO | GOTO Expr | Go to Address | 2 | 2 | None |
| | GOTO Wn | Go to Indirect | 1 | 2 | None |
| INC | INC f | $f = f + 1$ | 1 | 1 | C, DC, N, OV, Z |
| | INC f, WREG | WREG = $f + 1$ | 1 | 1 | C, DC, N, OV, Z |
| | INC Ws, Wd | Wd = Ws + 1 | 1 | 1 | C, DC, N, OV, Z |
| INC2 | INC2 f | $f = f + 2$ | 1 | 1 | C, DC, N, OV, Z |
| | INC2 f, WREG | WREG = $f + 2$ | 1 | 1 | C, DC, N, OV, Z |
| | INC2 Ws, Wd | Wd = Ws + 2 | 1 | 1 | C, DC, N, OV, Z |
| IOR | IOR f | $f = f .IOR. WREG$ | 1 | 1 | N, Z |
| | IOR f, WREG | WREG = $f .IOR. WREG$ | 1 | 1 | N, Z |
| | IOR #lit10, Wn | Wd = lit10 .IOR. Wd | 1 | 1 | N, Z |
| | IOR Wb, Ws, Wd | Wd = Wb .IOR. Ws | 1 | 1 | N, Z |
| | IOR Wb, #lit5, Wd | Wd = Wb .IOR. lit5 | 1 | 1 | N, Z |
| LNK | LNK #lit14 | Link Frame Pointer | 1 | 1 | None |
| LSR | LSR f | f = Logical Right Shift f | 1 | 1 | C, N, OV, Z |
| | LSR f, WREG | WREG = Logical Right Shift f | 1 | 1 | C, N, OV, Z |
| | LSR Ws, Wd | Wd = Logical Right Shift Ws | 1 | 1 | C, N, OV, Z |
| | LSR Wb, Wns, Wnd | Wnd = Logical Right Shift Wb by Wns | 1 | 1 | N, Z |
| | LSR Wb, #lit5, Wnd | Wnd = Logical Right Shift Wb by lit5 | 1 | 1 | N, Z |
| MOV | MOV f, Wn | Move f to Wn | 1 | 1 | None |
| | MOV [Wns+Slit10], Wnd | Move [Wns+Slit10] to Wnd | 1 | 1 | None |
| | MOV f | Move f to f | 1 | 1 | N, Z |
| | MOV f, WREG | Move f to WREG | 1 | 1 | N, Z |
| | MOV #lit16, Wn | Move 16-bit Literal to Wn | 1 | 1 | None |
| | MOV.b #lit8, Wn | Move 8-bit Literal to Wn | 1 | 1 | None |
| | MOV Wn, f | Move Wn to f | 1 | 1 | None |
| | MOV Wns, [Wns+Slit10] | Move Wns to [Wns+Slit10] | 1 | 1 | |
| | MOV Wso, Wdo | Move Ws to Wd | 1 | 1 | None |
| | MOV WREG, f | Move WREG to f | 1 | 1 | N, Z |
| | MOV.D Wns, Wd | Move Double from W(ns):W(ns+1) to Wd | 1 | 2 | None |
| | MOV.D Ws, Wnd | Move Double from Ws to W(nd+1):W(nd) | 1 | 2 | None |
| MUL | MUL.SS Wb, Ws, Wnd | {Wnd+1, Wnd} = Signed(Wb) * Signed(Ws) | 1 | 1 | None |
| | MUL.SU Wb, Ws, Wnd | {Wnd+1, Wnd} = Signed(Wb) * Unsigned(Ws) | 1 | 1 | None |
| | MUL.US Wb, Ws, Wnd | {Wnd+1, Wnd} = Unsigned(Wb) * Signed(Ws) | 1 | 1 | None |
| | MUL.UU Wb, Ws, Wnd | {Wnd+1, Wnd} = Unsigned(Wb) * Unsigned(Ws) | 1 | 1 | None |
| | MUL.SU Wb, #lit5, Wnd | {Wnd+1, Wnd} = Signed(Wb) * Unsigned(lit5) | 1 | 1 | None |
| | MUL.UU Wb, #lit5, Wnd | {Wnd+1, Wnd} = Unsigned(Wb) * Unsigned(lit5) | 1 | 1 | None |
| | MUL f | W3:W2 = $f * WREG$ | 1 | 1 | None |
| NEG | NEG f | $f = \bar{f} + 1$ | 1 | 1 | C, DC, N, OV, Z |
| | NEG f, WREG | WREG = $\bar{f} + 1$ | 1 | 1 | C, DC, N, OV, Z |
| | NEG Ws, Wd | Wd = $\overline{Ws} + 1$ | 1 | 1 | C, DC, N, OV, Z |
| NOP | NOP | No Operation | 1 | 1 | None |
| | NOPR | No Operation | 1 | 1 | None |
| POP | POP f | Pop f from Top-of-Stack (TOS) | 1 | 1 | None |
| | POP Wdo | Pop from Top-of-Stack (TOS) to Wdo | 1 | 1 | None |
| | POP.D Wnd | Pop from Top-of-Stack (TOS) to W(nd):W(nd+1) | 1 | 2 | None |
| | POP.S | Pop Shadow Registers | 1 | 1 | All |
| PUSH | PUSH f | Push f to Top-of-Stack (TOS) | 1 | 1 | None |
| | PUSH Wso | Push Wso to Top-of-Stack (TOS) | 1 | 1 | None |
| | PUSH.D Wns | Push W(ns):W(ns+1) to Top-of-Stack (TOS) | 1 | 2 | None |
| | PUSH.S | Push Shadow Registers | 1 | 1 | None |

PIC24FJ256DA210 FAMILY

[查询PIC24FJ256DA106供应商](#)

TABLE 29-2: INSTRUCTION SET OVERVIEW (CONTINUED)

| Assembly Mnemonic | Assembly Syntax | Description | # of Words | # of Cycles | Status Flags Affected |
|-------------------|---------------------|---|------------|-------------|-----------------------|
| PWRSV | PWRSV #lit1 | Go into Sleep or Idle mode | 1 | 1 | WDTO, Sleep |
| RCALL | RCALL Expr | Relative Call | 1 | 2 | None |
| | RCALL Wn | Computed Call | 1 | 2 | None |
| REPEAT | REPEAT #lit14 | Repeat Next Instruction lit14 + 1 times | 1 | 1 | None |
| | REPEAT Wn | Repeat Next Instruction (Wn) + 1 times | 1 | 1 | None |
| RESET | RESET | Software Device Reset | 1 | 1 | None |
| RETFIE | RETFIE | Return from Interrupt | 1 | 3 (2) | None |
| RETLW | RETLW #lit10, Wn | Return with Literal in Wn | 1 | 3 (2) | None |
| RETURN | RETURN | Return from Subroutine | 1 | 3 (2) | None |
| RLC | RLC f | f = Rotate Left through Carry f | 1 | 1 | C, N, Z |
| | RLC f, WREG | WREG = Rotate Left through Carry f | 1 | 1 | C, N, Z |
| | RLC Ws, Wd | Wd = Rotate Left through Carry Ws | 1 | 1 | C, N, Z |
| RLNC | RLNC f | f = Rotate Left (No Carry) f | 1 | 1 | N, Z |
| | RLNC f, WREG | WREG = Rotate Left (No Carry) f | 1 | 1 | N, Z |
| | RLNC Ws, Wd | Wd = Rotate Left (No Carry) Ws | 1 | 1 | N, Z |
| RRC | RRC f | f = Rotate Right through Carry f | 1 | 1 | C, N, Z |
| | RRC f, WREG | WREG = Rotate Right through Carry f | 1 | 1 | C, N, Z |
| | RRC Ws, Wd | Wd = Rotate Right through Carry Ws | 1 | 1 | C, N, Z |
| RRNC | RRNC f | f = Rotate Right (No Carry) f | 1 | 1 | N, Z |
| | RRNC f, WREG | WREG = Rotate Right (No Carry) f | 1 | 1 | N, Z |
| | RRNC Ws, Wd | Wd = Rotate Right (No Carry) Ws | 1 | 1 | N, Z |
| SE | SE Ws, Wnd | Wnd = Sign-Extended Ws | 1 | 1 | C, N, Z |
| SETM | SETM f | f = FFFFh | 1 | 1 | None |
| | SETM WREG | WREG = FFFFh | 1 | 1 | None |
| | SETM Ws | Ws = FFFFh | 1 | 1 | None |
| SL | SL f | f = Left Shift f | 1 | 1 | C, N, OV, Z |
| | SL f, WREG | WREG = Left Shift f | 1 | 1 | C, N, OV, Z |
| | SL Ws, Wd | Wd = Left Shift Ws | 1 | 1 | C, N, OV, Z |
| | SL Wb, Wns, Wnd | Wnd = Left Shift Wb by Wns | 1 | 1 | N, Z |
| | SL Wb, #lit5, Wnd | Wnd = Left Shift Wb by lit5 | 1 | 1 | N, Z |
| SUB | SUB f | f = f - WREG | 1 | 1 | C, DC, N, OV, Z |
| | SUB f, WREG | WREG = f - WREG | 1 | 1 | C, DC, N, OV, Z |
| | SUB #lit10, Wn | Wn = Wn - lit10 | 1 | 1 | C, DC, N, OV, Z |
| | SUB Wb, Ws, Wd | Wd = Wb - Ws | 1 | 1 | C, DC, N, OV, Z |
| | SUB Wb, #lit5, Wd | Wd = Wb - lit5 | 1 | 1 | C, DC, N, OV, Z |
| SUBB | SUBB f | f = f - WREG - (\overline{C}) | 1 | 1 | C, DC, N, OV, Z |
| | SUBB f, WREG | WREG = f - WREG - (\overline{C}) | 1 | 1 | C, DC, N, OV, Z |
| | SUBB #lit10, Wn | Wn = Wn - lit10 - (\overline{C}) | 1 | 1 | C, DC, N, OV, Z |
| | SUBB Wb, Ws, Wd | Wd = Wb - Ws - (\overline{C}) | 1 | 1 | C, DC, N, OV, Z |
| | SUBB Wb, #lit5, Wd | Wd = Wb - lit5 - (\overline{C}) | 1 | 1 | C, DC, N, OV, Z |
| SUBR | SUBR f | f = WREG - f | 1 | 1 | C, DC, N, OV, Z |
| | SUBR f, WREG | WREG = WREG - f | 1 | 1 | C, DC, N, OV, Z |
| | SUBR Wb, Ws, Wd | Wd = Ws - Wb | 1 | 1 | C, DC, N, OV, Z |
| | SUBR Wb, #lit5, Wd | Wd = lit5 - Wb | 1 | 1 | C, DC, N, OV, Z |
| SUBBR | SUBBR f | f = WREG - f - (\overline{C}) | 1 | 1 | C, DC, N, OV, Z |
| | SUBBR f, WREG | WREG = WREG - f - (\overline{C}) | 1 | 1 | C, DC, N, OV, Z |
| | SUBBR Wb, Ws, Wd | Wd = Ws - Wb - (\overline{C}) | 1 | 1 | C, DC, N, OV, Z |
| | SUBBR Wb, #lit5, Wd | Wd = lit5 - Wb - (\overline{C}) | 1 | 1 | C, DC, N, OV, Z |
| SWAP | SWAP.b Wn | Wn = Nibble Swap Wn | 1 | 1 | None |
| | SWAP Wn | Wn = Byte Swap Wn | 1 | 1 | None |
| TBLRDH | TBLRDH Ws, Wd | Read Prog<23:16> to Wd<7:0> | 1 | 2 | None |

PIC24FJ256DA210 FAMILY

[查询PIC24FJ256DA106供应商](#)

TABLE 29-2: INSTRUCTION SET OVERVIEW (CONTINUED)

| Assembly Mnemonic | Assembly Syntax | Description | # of Words | # of Cycles | Status Flags Affected |
|-------------------|--------------------------|------------------------------|------------|-------------|-----------------------|
| TBLRDL | TBLRDL <i>Ws, Wd</i> | Read Prog<15:0> to Wd | 1 | 2 | None |
| TBLWTH | TBLWTH <i>Ws, Wd</i> | Write Ws<7:0> to Prog<23:16> | 1 | 2 | None |
| TBLWTL | TBLWTL <i>Ws, Wd</i> | Write Ws to Prog<15:0> | 1 | 2 | None |
| ULNK | ULNK | Unlink Frame Pointer | 1 | 1 | None |
| XOR | XOR <i>f</i> | $f = f .XOR. WREG$ | 1 | 1 | N, Z |
| | XOR <i>f, WREG</i> | $WREG = f .XOR. WREG$ | 1 | 1 | N, Z |
| | XOR <i>#lit10, Wn</i> | $Wd = lit10 .XOR. Wd$ | 1 | 1 | N, Z |
| | XOR <i>Wb, Ws, Wd</i> | $Wd = Wb .XOR. Ws$ | 1 | 1 | N, Z |
| | XOR <i>Wb, #lit5, Wd</i> | $Wd = Wb .XOR. lit5$ | 1 | 1 | N, Z |
| ZE | ZE <i>Ws, Wnd</i> | $Wnd = Zero-Extend Ws$ | 1 | 1 | C, Z, N |

PIC24FJ256DA210 FAMILY

[查询PIC24FJ256DA106供应商](#)

NOTES:

PIC24FJ256DA210 FAMILY

[查询PIC24FJ256DA106供应商](#)

30.0 ELECTRICAL CHARACTERISTICS

This section provides an overview of the PIC24FJ256DA210 family electrical characteristics. Additional information will be provided in future revisions of this document as it becomes available.

Absolute maximum ratings for the PIC24FJ256DA210 family are listed below. Exposure to these maximum rating conditions for extended periods may affect device reliability. Functional operation of the device at these, or any other conditions above the parameters indicated in the operation listings of this specification, is not implied.

Absolute Maximum Ratings^(†)

| | |
|--|-----------------------|
| Ambient temperature under bias | -40°C to +100°C |
| Storage temperature | -65°C to +150°C |
| Voltage on VDD with respect to VSS | -0.3V to +4.0V |
| Voltage on any combined analog and digital pin and MCLR, with respect to VSS | -0.3V to (VDD + 0.3V) |
| Voltage on any digital only pin with respect to VSS when VDD < 3.0V | -0.3V to (VDD + 0.3V) |
| Voltage on any digital only pin with respect to VSS when VDD > 3.0V | -0.3V to (+5.5V) |
| Voltage on VBUS pin with respect to VSS, independent of VDD or VUSB | -0.3V to (+5.5V) |
| Maximum current out of VSS pin | 300 mA |
| Maximum current into VDD pin (Note 1) | 250 mA |
| Maximum output current sunk by any I/O pin | 25 mA |
| Maximum output current sourced by any I/O pin | 25 mA |
| Maximum current sunk by all ports | 200 mA |
| Maximum current sourced by all ports (Note 1) | 200 mA |

Note 1: Maximum allowable current is a function of device maximum power dissipation (see Table 30-1).

†NOTICE: Stresses above those listed under “Absolute Maximum Ratings” may cause permanent damage to the device. This is a stress rating only and functional operation of the device at those or any other conditions above those indicated in the operation listings of this specification is not implied. Exposure to maximum rating conditions for extended periods may affect device reliability.

PIC24FJ256DA210 FAMILY

[查询PIC24FJ256DA106供应商](#)

30.1 DC Characteristics

FIGURE 30-1: PIC24FJ256DA210 FAMILY VOLTAGE-FREQUENCY GRAPH (INDUSTRIAL)

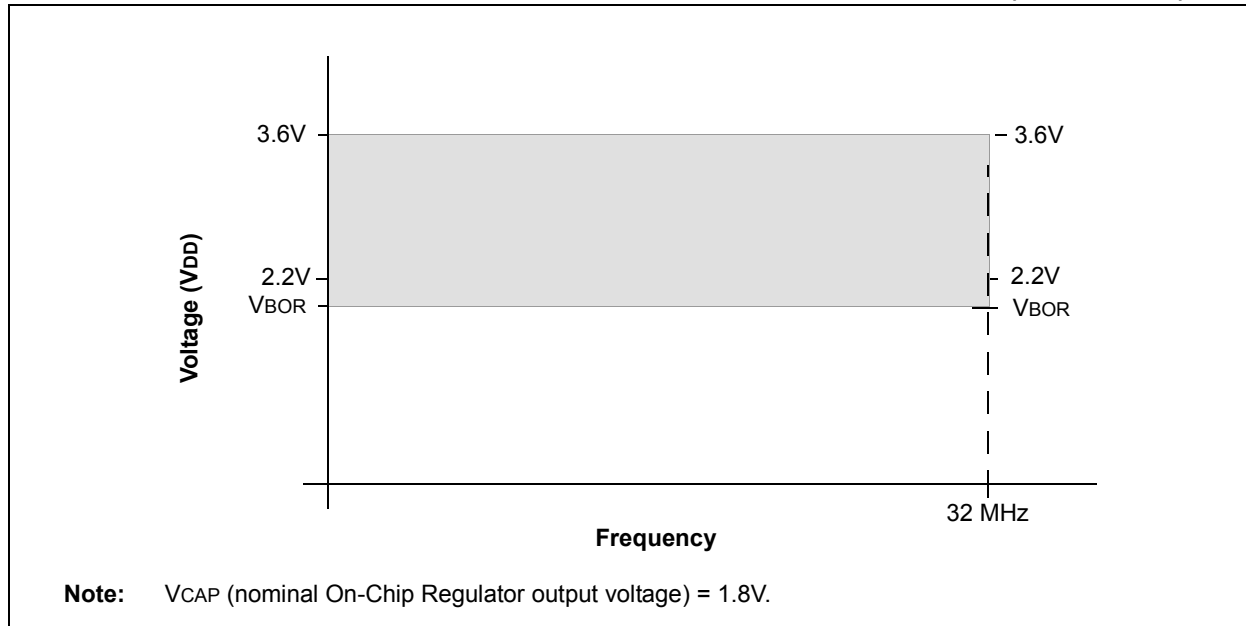

TABLE 30-1: THERMAL OPERATING CONDITIONS

| Rating | Symbol | Min | Typ | Max | Unit |
|---|--------|----------------------------------|-----|------|------|
| PIC24FJ256DA210 family: | | | | | |
| Operating Junction Temperature Range | TJ | -40 | — | +125 | °C |
| Operating Ambient Temperature Range | TA | -40 | — | +85 | °C |
| Power Dissipation (with ENVREG = 1): Internal Chip Power Dissipation: $P_{INT} = V_{DD} \times (I_{DD} - \sum I_{OH})$ I/O Pin Power Dissipation: $P_{I/O} = \sum (\{V_{DD} - V_{OH}\} \times I_{OH}) + \sum (V_{OL} \times I_{OL})$ | PD | PINT + PI/O | | | W |
| Maximum Allowed Power Dissipation | PDMAX | $(T_{JMAX} - T_A) / \theta_{JA}$ | | | W |

TABLE 30-2: THERMAL PACKAGING CHARACTERISTICS

| Characteristic | Symbol | Typ | Max | Unit | Note |
|--|---------------|------|-----|------|----------|
| Package Thermal Resistance, 12x12x1 mm TQFP | θ_{JA} | 69.4 | — | °C/W | (Note 1) |
| Package Thermal Resistance, 10x10x1 mm TQFP | θ_{JA} | 76.6 | — | °C/W | (Note 1) |
| Package Thermal Resistance, 9x9x0.9 mm QFN | θ_{JA} | 28.0 | — | °C/W | (Note 1) |
| Package Thermal Resistance, 10x10x1.1 mm BGA | θ_{JA} | 40.2 | — | °C/W | (Note 1) |

Note 1: Junction to ambient thermal resistance, Theta-JA (θ_{JA}) numbers are achieved by package simulations.

PIC24FJ256DA210 FAMILY

[查询PIC24FJ256DA106供应商](#)

TABLE 30-3: DC CHARACTERISTICS: TEMPERATURE AND VOLTAGE SPECIFICATIONS

| DC CHARACTERISTICS | | | Standard Operating Conditions: 2.2V to 3.6V (unless otherwise stated) Operating temperature $-40^{\circ}\text{C} \leq T_A \leq +85^{\circ}\text{C}$ for Industrial | | | | |
|--------------------------|---------------------------------|---|---|-------------------------|-----|-------|------------------------------------|
| Param No. | Symbol | Characteristic | Min | Typ | Max | Units | Conditions |
| Operating Voltage | | | | | | | |
| DC10 | Supply Voltage | | | | | | |
| | VDD | | VBOR | — | 3.6 | V | Regulator enabled |
| | V _{CAP} ⁽²⁾ | | — | 1.8V | — | V | Regulator enabled |
| DC12 | VDR | RAM Data Retention Voltage⁽¹⁾ | 1.5 | — | — | V | |
| DC16 | VPOR | VDD Start Voltage to Ensure Internal Power-on Reset Signal | V _{SS} | — | — | V | |
| DC17 | SVDD | VDD Rise Rate to Ensure Internal Power-on Reset Signal | 0.05 | — | — | V/ms | 0-3.3V in 66 ms 0-2.5V in 50 ms |
| | VBOR | Brown-out Reset Voltage on VDD Transition, High-to-Low | 2.0 | 2.10 | 2.2 | V | Regulator enabled |
| | VLVD | LVD Trip Voltage | — | V _{BOR} + 0.10 | — | V | |

Note 1: This is the limit to which the RAM data can be retained, while the on-chip regulator output voltage starts following the VDD.

2: This is the on-chip regulator output voltage specification.

PIC24FJ256DA210 FAMILY

[查询PIC24FJ256DA106供应商](#)

TABLE 30-4: DC CHARACTERISTICS: OPERATING CURRENT (IDD)

| DC CHARACTERISTICS | | | Standard Operating Conditions: 2.2V to 3.6V (unless otherwise stated) Operating temperature $-40^{\circ}\text{C} \leq T_A \leq +85^{\circ}\text{C}$ for Industrial | | |
|--|------------------------|-----|---|------------|--------------------------------------|
| Parameter No. | Typical ⁽¹⁾ | Max | Units | Conditions | |
| Operating Current (IDD)⁽²⁾ | | | | | |
| DC20D | 0.8 | 1.3 | mA | -40°C | 3.3V ⁽³⁾ 1 MIPS |
| DC20E | 0.8 | 1.3 | mA | +25°C | |
| DC20F | 0.8 | 1.3 | mA | +85°C | |
| DC23D | 3.0 | 4.8 | mA | -40°C | 3.3V ⁽³⁾ 4 MIPS |
| DC23E | 3.0 | 4.8 | mA | +25°C | |
| DC23F | 3.0 | 4.8 | mA | +85°C | |
| DC24D | 12.0 | 18 | mA | -40°C | 3.3V ⁽³⁾ 16 MIPS |
| DC24E | 12.0 | 18 | mA | +25°C | |
| DC24F | 12.0 | 18 | mA | +85°C | |
| DC31D | 55 | 95 | μA | -40°C | 3.3V ⁽³⁾ LPRC (31 kHz) |
| DC31E | 55 | 95 | μA | +25°C | |
| DC31F | 135 | 225 | μA | +85°C | |

Note 1: Data in "Typical" column is at 3.3V, 25°C unless otherwise stated. Parameters are for design guidance only and are not tested.

- 2:** The supply current is mainly a function of the operating voltage and frequency. Other factors, such as I/O pin loading and switching rate, oscillator type, internal code execution pattern and temperature, also have an impact on the current consumption. The test conditions for all IDD measurements are as follows: OSCI driven with external square wave from rail to rail. All I/O pins are configured as inputs and pulled to VDD. MCLR = VDD; WDT and FSCM are disabled. CPU, SRAM, program memory and data memory are operational. No peripheral modules are operating and all of the Peripheral Module Disable (PMD) bits are set.
- 3:** On-chip voltage regulator enabled (ENVREG tied to VDD). Brown-out Reset (BOR) is enabled.

PIC24FJ256DA210 FAMILY

[查询PIC24FJ256DA106供应商](#)

TABLE 30-5: DC CHARACTERISTICS: IDLE CURRENT (I_{IDLE})

| DC CHARACTERISTICS | | | Standard Operating Conditions: 2.2V to 3.6V (unless otherwise stated) Operating temperature $-40^{\circ}\text{C} \leq T_A \leq +85^{\circ}\text{C}$ for Industrial | | |
|--|------------------------|-----|---|-----------------------|--------------------------------------|
| Parameter No. | Typical ⁽¹⁾ | Max | Units | Conditions | |
| Idle Current (I_{IDLE})⁽²⁾ | | | | | |
| DC40D | 170 | 320 | μA | -40°C | 3.3V ⁽³⁾ 1 MIPS |
| DC40E | 170 | 320 | μA | $+25^{\circ}\text{C}$ | |
| DC40F | 220 | 380 | μA | $+85^{\circ}\text{C}$ | |
| DC43D | 0.6 | 1.2 | mA | -40°C | 3.3V ⁽³⁾ 4 MIPS |
| DC43E | 0.6 | 1.2 | mA | $+25^{\circ}\text{C}$ | |
| DC43F | 0.7 | 1.2 | mA | $+85^{\circ}\text{C}$ | |
| DC47D | 2.3 | 4.8 | mA | -40°C | 3.3V ⁽³⁾ 16 MIPS |
| DC47E | 2.3 | 4.8 | mA | $+25^{\circ}\text{C}$ | |
| DC47F | 2.4 | 4.8 | mA | $+85^{\circ}\text{C}$ | |
| DC50D | 0.8 | 1.8 | mA | -40°C | 3.3V ⁽³⁾ FRC (4 MIPS) |
| DC50E | 0.8 | 1.8 | mA | $+25^{\circ}\text{C}$ | |
| DC50F | 1.0 | 1.8 | mA | $+85^{\circ}\text{C}$ | |
| DC51D | 40.0 | 85 | μA | -40°C | 3.3V ⁽³⁾ LPRC (31 kHz) |
| DC51E | 40.0 | 85 | μA | $+25^{\circ}\text{C}$ | |
| DC51F | 120.0 | 210 | μA | $+85^{\circ}\text{C}$ | |

- Note 1:** Data in "Typical" column is at 3.3V, 25°C unless otherwise stated. Parameters are for design guidance only and are not tested.
- 2:** Base I_{IDLE} current is measured with the core off; OSCI driven with external square wave from rail to rail. All I/O pins are configured as inputs and pulled to V_{DD}. MCLR = V_{DD}; WDT and FSCM are disabled. No peripheral modules are operating and all of the Peripheral Module Disable (PMD) bits are set.
- 3:** On-chip voltage regulator enabled (ENVREG tied to V_{DD}). Brown-out Reset (BOR) is enabled.

PIC24FJ256DA210 FAMILY

[查询PIC24FJ256DA106供应商](#)

TABLE 30-6: DC CHARACTERISTICS: POWER-DOWN CURRENT (IPD)

| DC CHARACTERISTICS | | | Standard Operating Conditions: 2.2V to 3.6V (unless otherwise stated) Operating temperature $-40^{\circ}\text{C} \leq T_A \leq +85^{\circ}\text{C}$ for Industrial | | |
|---|------------------------|-----|---|-----------------------|--|
| Parameter No. | Typical ⁽¹⁾ | Max | Units | Conditions | |
| Power-Down Current (IPD)⁽²⁾ | | | | | |
| DC60D | 20.0 | 45 | μA | -40°C | 3.3V ⁽³⁾ Base power-down current ⁽⁴⁾ |
| DC60E | 20.0 | 45 | μA | $+25^{\circ}\text{C}$ | |
| DC60H | 55.0 | 105 | μA | $+60^{\circ}\text{C}$ | |
| DC60F | 95.0 | 185 | μA | $+85^{\circ}\text{C}$ | |
| DC61D | 1.0 | 3.5 | μA | -40°C | 3.3V ⁽³⁾ 31 kHz LPRC oscillator with RTCC, WDT or Timer1: ΔILPRC ⁽⁴⁾ |
| DC61E | 1.0 | 3.5 | μA | $+25^{\circ}\text{C}$ | |
| DC61H | 1.0 | 3.5 | μA | $+60^{\circ}\text{C}$ | |
| DC61F | 2.5 | 6.5 | μA | $+85^{\circ}\text{C}$ | |
| DC62D | 1.5 | 6 | μA | -40°C | 3.3V ⁽³⁾ Low drive strength, 32 kHz crystal with RTCC or Timer1: ΔIsosc ; $\text{SOSCSEL}<1:0> = 01$ ⁽⁴⁾ |
| DC62E | 1.5 | 6 | μA | $+25^{\circ}\text{C}$ | |
| DC62H | 1.5 | 6 | μA | $+60^{\circ}\text{C}$ | |
| DC62F | 8.0 | 18 | μA | $+85^{\circ}\text{C}$ | |
| DC63D | 4.0 | 18 | μA | -40°C | 3.3V ⁽³⁾ 32 kHz crystal with RTCC or Timer1: ΔIsosc ; $\text{SOSCSEL}<1:0> = 11$ ⁽⁴⁾ |
| DC63E | 4.0 | 18 | μA | $+25^{\circ}\text{C}$ | |
| DC63H | 6.5 | 18 | μA | $+60^{\circ}\text{C}$ | |
| DC63F | 12.0 | 25 | μA | $+85^{\circ}\text{C}$ | |

Note 1: Data in the Typical column is at 3.3V, 25°C unless otherwise stated. Parameters are for design guidance only and are not tested.

- 2:** Base IPD is measured with the device in Sleep mode (all peripherals and clocks are shut down). All I/Os are configured as inputs and pulled high. WDT, etc., are all switched off, PMSLP bit is clear and the Peripheral Module Disable (PMD) bits for all unused peripherals are set.
- 3:** On-chip voltage regulator enabled (ENVREG tied to VDD). Brown-out Reset (BOR) is enabled.
- 4:** The Δ current is the additional current consumed when the module is enabled. This current should be added to the base IPD current.

PIC24FJ256DA210 FAMILY

[查询PIC24FJ256DA106供应商](#)

TABLE 30-7: DC CHARACTERISTICS: I/O PIN INPUT SPECIFICATIONS

| DC CHARACTERISTICS | | | Standard Operating Conditions: 2.2V to 3.6V (unless otherwise stated) Operating temperature $-40^{\circ}\text{C} \leq T_A \leq +85^{\circ}\text{C}$ for Industrial | | | | |
|--------------------|-----------------|---|---|--------------------|------------------------|--------|---|
| Param No. | Symbol | Characteristic | Min | Typ ⁽¹⁾ | Max | Units | Conditions |
| | V _{IL} | Input Low Voltage⁽³⁾ | | | | | |
| DI10 | | I/O Pins with ST Buffer | V _{SS} | — | 0.2 V _{DD} | V | |
| DI11 | | I/O Pins with TTL Buffer | V _{SS} | — | 0.15 V _{DD} | V | |
| DI15 | | $\overline{\text{MCLR}}$ | V _{SS} | — | 0.2 V _{DD} | V | |
| DI16 | | OSCI (XT mode) | V _{SS} | — | 0.2 V _{DD} | V | |
| DI17 | | OSCI (HS mode) | V _{SS} | — | 0.2 V _{DD} | V | |
| DI18 | | I/O Pins with I ² C™ Buffer: | V _{SS} | — | 0.3 V _{DD} | V | |
| DI19 | | I/O Pins with SMBus Buffer: | V _{SS} | — | 0.8 | V | SMBus enabled |
| | V _{IH} | Input High Voltage⁽³⁾ | | | | | |
| DI20 | | I/O Pins with ST Buffer: with Analog Functions, Digital Only | 0.8 V _{DD} 0.8 V _{DD} | — — | V _{DD} 5.5 | V V | |
| DI21 | | I/O Pins with TTL Buffer: with Analog Functions, Digital Only | 0.25 V _{DD} + 0.8 0.25 V _{DD} + 0.8 | — — | V _{DD} 5.5 | V V | |
| DI25 | | $\overline{\text{MCLR}}$ | 0.8 V _{DD} | — | V _{DD} | V | |
| DI26 | | OSCI (XT mode) | 0.7 V _{DD} | — | V _{DD} | V | |
| DI27 | | OSCI (HS mode) | 0.7 V _{DD} | — | V _{DD} | V | |
| DI28 | | I/O Pins with I ² C™ Buffer: with Analog Functions, Digital Only | 0.7 V _{DD} 0.7 V _{DD} | — — | V _{DD} 5.5 | V V | |
| DI29 | | I/O Pins with SMBus Buffer: with Analog Functions, Digital Only | 2.1 2.1 | — — | V _{DD} 5.5 | V V | 2.5V ≤ V _{PIN} ≤ V _{DD} |
| DI30 | ICNPU | CNxx Pull-up Current | 150 | 350 | 550 | μA | V _{DD} = 3.3V, V _{PIN} = V _{SS} |
| DI30A | ICNPD | CNxx Pull-down Current | 15 | 70 | 150 | μA | V _{DD} = 3.3V, V _{PIN} = V _{DD} |
| | I _{IL} | Input Leakage Current⁽²⁾ | | | | | |
| DI50 | | I/O Ports | — | — | ±1 | μA | V _{SS} ≤ V _{PIN} ≤ V _{DD} , pin at high-impedance |
| DI51 | | Analog Input Pins | — | — | ±1 | μA | V _{SS} ≤ V _{PIN} ≤ V _{DD} , pin at high-impedance |
| DI55 | | $\overline{\text{MCLR}}$ | — | — | ±1 | μA | V _{SS} ≤ V _{PIN} ≤ V _{DD} |
| DI56 | | OSCI/CLKI | — | — | ±1 | μA | V _{SS} ≤ V _{PIN} ≤ V _{DD} , EC, XT and HS modes |

Note 1: Data in “Typ” column is at 3.3V, 25°C unless otherwise stated. Parameters are for design guidance only and are not tested.

2: Negative current is defined as current sourced by the pin.

3: Refer to Table 1-1 for I/O pins buffer types.

PIC24FJ256DA210 FAMILY

[查询PIC24FJ256DA106供应商](#)

TABLE 30-8: DC CHARACTERISTICS: I/O PIN OUTPUT SPECIFICATIONS

| DC CHARACTERISTICS | | | Standard Operating Conditions: 2.2V to 3.6V (unless otherwise stated) Operating temperature $-40^{\circ}\text{C} \leq T_A \leq +85^{\circ}\text{C}$ for Industrial | | | | |
|--------------------|--------|---|---|--------------------|-----|-------|---------------------------|
| Param No. | Symbol | Characteristic | Min | Typ ⁽¹⁾ | Max | Units | Conditions |
| DO10 | VOL | Output Low Voltage I/O Ports | — | — | 0.4 | V | IOL = 6.6 mA, VDD = 3.6V |
| | | | — | — | 0.4 | V | IOL = 5.0 mA, VDD = 2.2V |
| DO16 | | OSCO/CLKO | — | — | 0.4 | V | IOL = 6.6 mA, VDD = 3.6V |
| | | | — | — | 0.4 | V | IOL = 5.0 mA, VDD = 2.2V |
| DO20 | VOH | Output High Voltage I/O Ports | 3.0 | — | — | V | IOH = -3.0 mA, VDD = 3.6V |
| | | | 2.4 | — | — | V | IOH = -6.0 mA, VDD = 3.6V |
| | | | 1.65 | — | — | V | IOH = -1.0 mA, VDD = 2.2V |
| | | | 1.4 | — | — | V | IOH = -3.0 mA, VDD = 2.2V |
| DO26 | | OSCO/CLKO | 2.4 | — | — | V | IOH = -6.0 mA, VDD = 3.6V |
| | | | 1.4 | — | — | V | IOH = -1.0 mA, VDD = 2.2V |

Note 1: Data in "Typ" column is at 3.3V, 25°C unless otherwise stated. Parameters are for design guidance only and are not tested.

TABLE 30-9: DC CHARACTERISTICS: PROGRAM MEMORY

| DC CHARACTERISTICS | | | Standard Operating Conditions: 2.2V to 3.6V (unless otherwise stated) Operating temperature $-40^{\circ}\text{C} \leq T_A \leq +85^{\circ}\text{C}$ for Industrial | | | | |
|-----------------------------|--------|-----------------------------------|---|--------------------|-----|-------|--|
| Param No. | Symbol | Characteristic | Min | Typ ⁽¹⁾ | Max | Units | Conditions |
| Program Flash Memory | | | | | | | |
| D130 | EP | Cell Endurance | 10000 | — | — | E/W | -40°C to $+85^{\circ}\text{C}$ |
| D131 | VPR | VDD for Read | V _{MIN} | — | 3.6 | V | V _{MIN} = Minimum operating voltage |
| D132B | | VDD for Self-Timed Write | V _{MIN} | — | 3.6 | V | V _{MIN} = Minimum operating voltage |
| D133A | TIW | Self-Timed Word Write Cycle Time | — | 20 | — | μs | |
| | | Self-Timed Row Write Cycle Time | — | 1.5 | — | ms | |
| D133B | TIE | Self-Timed Page Erase Time | 20 | — | 40 | ms | |
| D134 | TRETD | Characteristic Retention | 20 | — | — | Year | If no other specifications are violated |
| D135 | IDDP | Supply Current during Programming | — | 16 | — | mA | |

Note 1: Data in "Typ" column is at 3.3V, 25°C unless otherwise stated.

PIC24FJ256DA210 FAMILY

[查询PIC24FJ256DA106供应商](#)

TABLE 30-10: INTERNAL VOLTAGE REGULATOR SPECIFICATIONS

| Operating Conditions: $-40^{\circ}\text{C} < T_A < +85^{\circ}\text{C}$ (unless otherwise stated) | | | | | | | |
|---|--------|----------------------------------|-----|-----|-----|---------------|--|
| Param No. | Symbol | Characteristics | Min | Typ | Max | Units | Comments |
| | VRGOUT | Regulator Output Voltage | — | 1.8 | — | V | |
| | VBG | Internal Band Gap Reference | — | 1.2 | — | V | |
| | CEFC | External Filter Capacitor Value | 4.7 | 10 | — | μF | Series resistance $< 3\ \text{Ohm}$ recommended; $< 5\ \text{Ohm}$ required. |
| | TVREG | | — | 10 | — | μs | VREGS = 1, VREGS = 0 with WUTSEL<1:0> = 01 or any POR or BOR |
| | | | — | 190 | — | μs | Sleep wake-up with VREGS = 0 and WUTSEL<1:0> = 11 |
| | TBG | Band Gap Reference Start-up Time | — | 1 | — | ms | |

30.2 AC Characteristics and Timing Parameters

The information contained in this section defines the PIC24FJ256DA210 family AC characteristics and timing parameters.

TABLE 30-11: TEMPERATURE AND VOLTAGE SPECIFICATIONS – AC

| Standard Operating Conditions: 2.2V to 3.6V (unless otherwise stated) | |
|---|--|
| AC CHARACTERISTICS | Operating temperature $-40^{\circ}\text{C} \leq T_A \leq +85^{\circ}\text{C}$ for Industrial |
| | Operating voltage V_{DD} range as described in Section 30.1 “DC Characteristics” . |

FIGURE 30-2: LOAD CONDITIONS FOR DEVICE TIMING SPECIFICATIONS

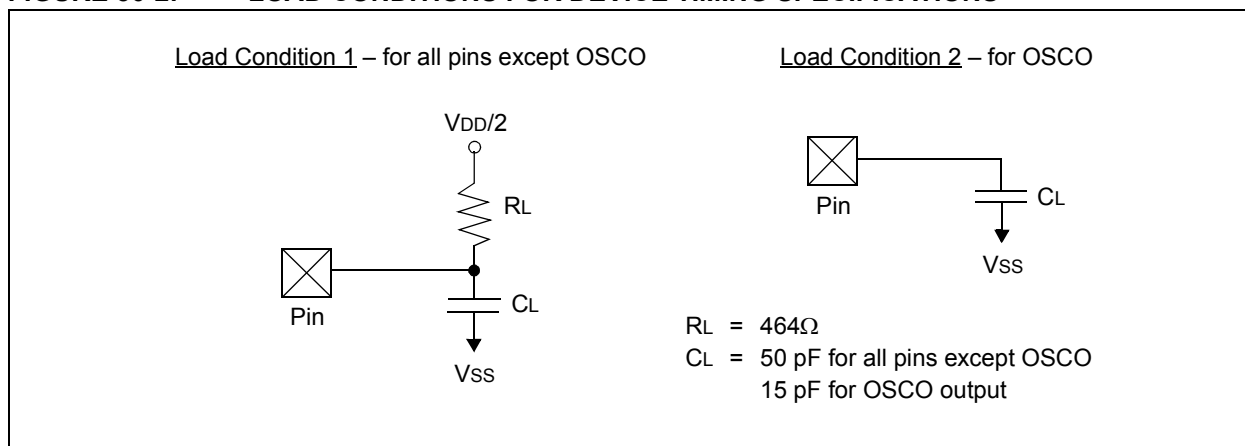

PIC24FJ256DA210 FAMILY

[查询PIC24FJ256DA106供应商](#)

TABLE 30-12: CAPACITIVE LOADING REQUIREMENTS ON OUTPUT PINS

| Param No. | Symbol | Characteristic | Min | Typ ⁽¹⁾ | Max | Units | Conditions |
|-----------|--------|-----------------------|-----|--------------------|-----|-------|--|
| DO50 | Cosco | OSCO/CLKO Pin | — | — | 15 | pF | In XT and HS modes when external clock is used to drive OSC1 |
| DO56 | Cio | All I/O Pins and OSCO | — | — | 50 | pF | EC mode |
| DO58 | Cb | SCLx, SDAx | — | — | 400 | pF | In I ² C™ mode |

Note 1: Data in “Typ” column is at 3.3V, 25°C unless otherwise stated. Parameters are for design guidance only and are not tested.

FIGURE 30-3: EXTERNAL CLOCK TIMING

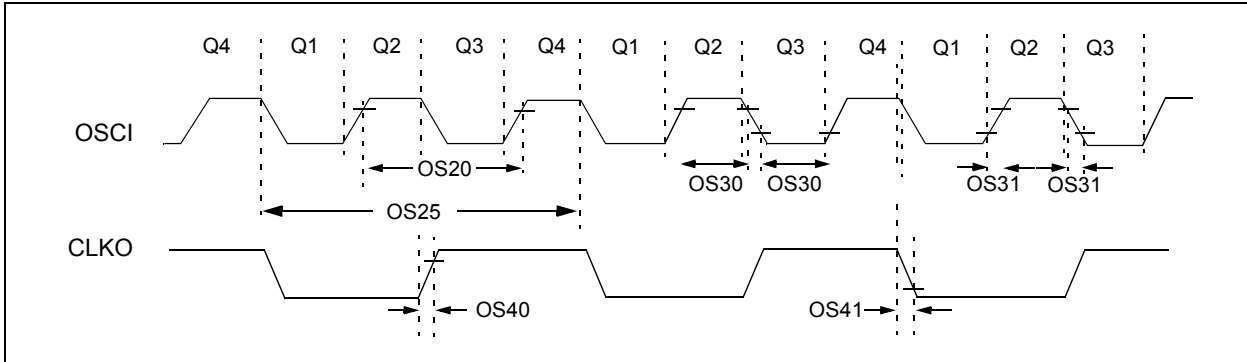

PIC24FJ256DA210 FAMILY

[查询PIC24FJ256DA106供应商](#)

TABLE 30-13: EXTERNAL CLOCK TIMING REQUIREMENTS

| AC CHARACTERISTICS | | | Standard Operating Conditions: 2.2V to 3.6V (unless otherwise stated) Operating temperature $-40^{\circ}\text{C} \leq T_A \leq +85^{\circ}\text{C}$ for Industrial | | | | |
|--------------------|---------------|--|---|--------------------|-----|-------|-----------------------------------|
| Param No. | Symbol | Characteristic | Min | Typ ⁽¹⁾ | Max | Units | Conditions |
| OS10 | Fosc | External CLKI Frequency (External clocks allowed only in EC mode) | DC | — | 32 | MHz | EC |
| | | | 4 | — | 48 | MHz | ECPLL |
| | | Oscillator Frequency | 3.5 | — | 10 | MHz | XT |
| | | | 4 | — | 8 | MHz | XTPLL |
| | | | 10 | — | 32 | MHz | HS |
| 10 | — | 32 | MHz | HSPLL | | | |
| 31 | — | 33 | kHz | SOSC | | | |
| OS20 | Tosc | Tosc = 1/Fosc | — | — | — | — | See parameter OS10 for Fosc value |
| OS25 | Tcy | Instruction Cycle Time ⁽²⁾ | 62.5 | — | DC | ns | |
| OS30 | TosL, TosH | External Clock in (OSCI) High or Low Time | 0.45 x Tosc | — | — | ns | EC |
| OS31 | TosR, TosF | External Clock in (OSCI) Rise or Fall Time | — | — | 20 | ns | EC |
| OS40 | TckR | CLKO Rise Time ⁽³⁾ | — | 6 | 10 | ns | |
| OS41 | TckF | CLKO Fall Time ⁽³⁾ | — | 6 | 10 | ns | |

Note 1: Data in “Typ” column is at 3.3V, 25°C unless otherwise stated. Parameters are for design guidance only and are not tested.

2: Instruction cycle period (Tcy) equals two times the input oscillator time base period. All specified values are based on characterization data for that particular oscillator type under standard operating conditions with the device executing code. Exceeding these specified limits may result in an unstable oscillator operation and/or higher than expected current consumption. All devices are tested to operate at “Min.” values with an external clock applied to the OSCI/CLKI pin. When an external clock input is used, the “Max.” cycle time limit is “DC” (no clock) for all devices.

3: Measurements are taken in EC mode. The CLKO signal is measured on the OSCO pin. CLKO is low for the Q1-Q2 period (1/2 Tcy) and high for the Q3-Q4 period (1/2 Tcy).

TABLE 30-14: PLL CLOCK TIMING SPECIFICATIONS (VDD = 2.2V TO 3.6V)

| AC CHARACTERISTICS | | | Standard Operating Conditions: 2.2V to 3.6V (unless otherwise stated) Operating temperature $-40^{\circ}\text{C} \leq T_A \leq +85^{\circ}\text{C}$ for Industrial | | | | |
|--------------------|--------|--|---|--------------------|-------|-------|------------|
| Param No. | Symbol | Characteristic ⁽¹⁾ | Min | Typ ⁽²⁾ | Max | Units | Conditions |
| OS50 | FPLLI | PLL Input Frequency Range ⁽²⁾ | 4 | — | 48 | MHz | ECPLL mode |
| | | | 4 | | 32 | MHz | HSPLL mode |
| | | | 4 | | 8 | MHz | XTPLL mode |
| OS51 | Fsys | PLL Output Frequency Range | 95.76 | — | 96.24 | MHz | |
| OS52 | TLOCK | PLL Start-up Time (Lock Time) | — | — | 200 | μs | |
| OS53 | DCLK | CLKO Stability (Jitter) | -0.25 | — | 0.25 | % | |

Note 1: These parameters are characterized but not tested in manufacturing.

2: Data in “Typ” column is at 3.3V, 25°C unless otherwise stated. Parameters are for design guidance only and are not tested.

PIC24FJ256DA210 FAMILY

[查询PIC24FJ256DA106供应商](#)

TABLE 30-15: INTERNAL RC ACCURACY

| AC CHARACTERISTICS | | Standard Operating Conditions: 2.2V to 3.6V (unless otherwise stated) Operating temperature $-40^{\circ}\text{C} \leq T_A \leq +85^{\circ}\text{C}$ for Industrial | | | | | |
|--------------------|---------------------------------------|---|-------|-----|-------|---|--|
| Param No. | Characteristic | Min | Typ | Max | Units | Conditions | |
| F20 | FRC Accuracy @ 8 MHz ^(1,2) | -1 | ±0.15 | 1 | % | $-40^{\circ}\text{C} \leq T_A \leq +85^{\circ}\text{C}$ | $2.2\text{V} \leq V_{DD} \leq 3.6\text{V}$ |
| F21 | LPRC @ 31 kHz | -20 | — | 20 | % | $-40^{\circ}\text{C} \leq T_A \leq +85^{\circ}\text{C}$ | V _{CAP} (on-chip regulator output voltage) = 1.8V |

- Note 1:** Frequency calibrated at 25°C and 3.3V. OSCTUN bits can be used to compensate for temperature drift.
Note 2: To achieve this accuracy, physical stress applied to the microcontroller package (ex., by flexing the PCB) must be kept to a minimum.

TABLE 30-16: RC OSCILLATOR START-UP TIME

| AC CHARACTERISTICS | | Standard Operating Conditions: 2.2V to 3.6V (unless otherwise stated) Operating temperature $-40^{\circ}\text{C} \leq T_A \leq +85^{\circ}\text{C}$ for Industrial | | | | | |
|--------------------|----------------|---|-----|-----|-------|------------|--|
| Param No. | Characteristic | Min | Typ | Max | Units | Conditions | |
| | TFRC | — | 15 | — | μs | | |
| | TLPRC | — | 50 | — | μs | | |

TABLE 30-17: RESET AND BROWN-OUT RESET REQUIREMENTS

| AC CHARACTERISTICS | | | Standard Operating Conditions: 2.2V to 3.6V (unless otherwise stated) Operating temperature $-40^{\circ}\text{C} \leq T_A \leq +85^{\circ}\text{C}$ for Industrial | | | | |
|--------------------|--------|--|---|-----|-----|-------|-----------------------|
| Param No. | Symbol | Characteristic | Min | Typ | Max | Units | Conditions |
| SY10 | TMCL | MCLR Pulse width (Low) | 2 | — | — | μs | |
| SY12 | TPOR | Power-on Reset Delay | — | 2 | — | μs | |
| SY13 | TIOZ | I/O High-Impedance from MCLR Low or Watchdog Timer Reset | — | — | 100 | ns | |
| SY25 | TBOR | Brown-out Reset Pulse Width | 1 | — | — | μs | $V_{DD} \leq V_{BOR}$ |
| | TRST | Internal State Reset Time | — | 50 | — | μs | |

PIC24FJ256DA210 FAMILY

[查询PIC24FJ256DA106供应商](#)

FIGURE 30-4: CLKO AND I/O TIMING CHARACTERISTICS

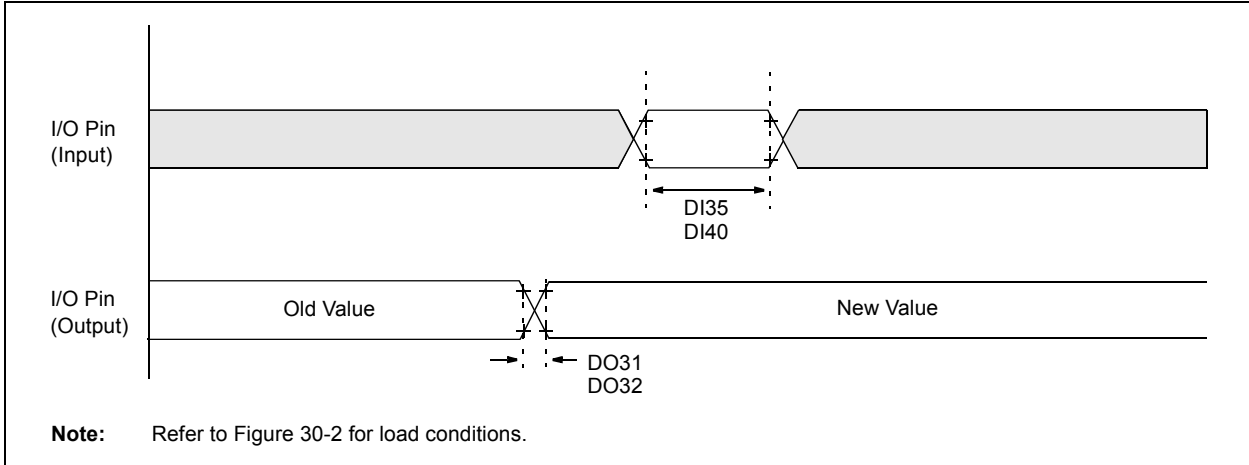

TABLE 30-18: CLKO AND I/O TIMING REQUIREMENTS

| AC CHARACTERISTICS | | | Standard Operating Conditions: 2.2V to 3.6V (unless otherwise stated) | | | | |
|--------------------|--------|-----------------------------------|--|--------------------|-----|-------|------------|
| | | | Operating temperature $-40^{\circ}\text{C} \leq T_A \leq +85^{\circ}\text{C}$ for Industrial | | | | |
| Param No. | Symbol | Characteristic | Min | Typ ⁽¹⁾ | Max | Units | Conditions |
| DO31 | TioR | Port Output Rise Time | — | 10 | 25 | ns | |
| DO32 | TioF | Port Output Fall Time | — | 10 | 25 | ns | |
| DI35 | TINP | INTx Pin High or Low Time (input) | 20 | — | — | ns | |
| DI40 | TRBP | CNx High or Low Time (input) | 2 | — | — | Tcy | |

Note 1: Data in “Typ” column is at 3.3V, 25°C unless otherwise stated.

PIC24FJ256DA210 FAMILY

[查询PIC24FJ256DA106供应商](#)

TABLE 30-19: ADC MODULE SPECIFICATIONS

| AC CHARACTERISTICS | | | Standard Operating Conditions: 2.2V to 3.6V (unless otherwise stated) Operating temperature $-40^{\circ}\text{C} \leq T_A \leq +85^{\circ}\text{C}$ | | | | |
|-------------------------|------------------|--|---|-----------|----------------------------------|----------|--|
| Param No. | Symbol | Characteristic | Min. | Typ | Max. | Units | Conditions |
| Device Supply | | | | | | | |
| AD01 | AVDD | Module VDD Supply | Greater of VDD – 0.3 or 2.2 | — | Lesser of VDD + 0.3 or 3.6 | V | |
| AD02 | AVSS | Module Vss Supply | VSS – 0.3 | — | VSS + 0.3 | V | |
| Reference Inputs | | | | | | | |
| AD05 | VREFH | Reference Voltage High | AVSS + 1.7 | — | AVDD | V | |
| AD06 | VREFL | Reference Voltage Low | AVSS | — | AVDD – 1.7 | V | |
| AD07 | VREF | Absolute Reference Voltage | AVSS – 0.3 | — | AVDD + 0.3 | V | |
| Analog Input | | | | | | | |
| AD10 | VINH-VINL | Full-Scale Input Span | VREFL | — | VREFH | V | (Note 2) |
| AD11 | VIN | Absolute Input Voltage | AVSS – 0.3 | — | AVDD + 0.3 | V | |
| AD12 | VINL | Absolute VINL Input Voltage | AVSS – 0.3 | — | AVDD/2 | V | |
| AD13 | | Leakage Current | — | ± 1.0 | ± 610 | nA | VINL = AVSS = VREFL = 0V, AVDD = VREFH = 3V, Source Impedance = 2.5 k Ω |
| AD17 | RIN | Recommended Impedance of Analog Voltage Source | — | — | 2.5K | Ω | 10-bit |
| ADC Accuracy | | | | | | | |
| AD20B | Nr | Resolution | — | 10 | — | bits | |
| AD21B | INL | Integral Nonlinearity | — | ± 1 | $< \pm 2$ | LSb | VINL = AVSS = VREFL = 0V, AVDD = VREFH = 3V |
| AD22B | DNL | Differential Nonlinearity | — | ± 0.5 | $< \pm 1$ | LSb | VINL = AVSS = VREFL = 0V, AVDD = VREFH = 3V |
| AD23B | GERR | Gain Error | — | ± 1 | ± 3 | LSb | VINL = AVSS = VREFL = 0V, AVDD = VREFH = 3V |
| AD24B | E _{OFF} | Offset Error | — | ± 1 | ± 2 | LSb | VINL = AVSS = VREFL = 0V, AVDD = VREFH = 3V |
| AD25B | | Monotonicity ⁽¹⁾ | — | — | — | — | Guaranteed |

Note 1: The ADC conversion result never decreases with an increase in the input voltage and has no missing codes.

2: Measurements taken with external VREF+ and VREF- used as the ADC voltage reference.

PIC24FJ256DA210 FAMILY

[查询PIC24FJ256DA106供应商](#)

TABLE 30-20: ADC CONVERSION TIMING REQUIREMENTS⁽¹⁾

| AC CHARACTERISTICS | | | Standard Operating Conditions: 2.2V to 3.6V (unless otherwise stated) Operating temperature $-40^{\circ}\text{C} \leq T_A \leq +85^{\circ}\text{C}$ | | | | |
|-------------------------|-------------------|---|---|-----|------|-------|---|
| Param No. | Symbol | Characteristic | Min. | Typ | Max. | Units | Conditions |
| Clock Parameters | | | | | | | |
| AD50 | TAD | ADC Clock Period | 75 | — | — | ns | T _{CY} = 75 ns, AD1CON3 in default state |
| AD51 | t _{RC} | ADC Internal RC Oscillator Period | — | 250 | — | ns | |
| Conversion Rate | | | | | | | |
| AD55 | t _{CONV} | Conversion Time | — | 12 | — | TAD | |
| AD56 | FCNV | Throughput Rate | — | — | 500 | ksps | AV _{DD} > 2.7V |
| AD57 | t _{SAMP} | Sample Time | — | 1 | — | TAD | |
| Clock Parameters | | | | | | | |
| AD61 | t _{PSS} | Sample Start Delay from Setting Sample bit (SAMP) | 2 | — | 3 | TAD | |

Note 1: Because the sample caps will eventually lose charge, clock rates below 10 kHz can affect linearity performance, especially at elevated temperatures.

PIC24FJ256DA210 FAMILY

[查询PIC24FJ256DA106供应商](#)

NOTES:

PIC24FJ256DA210 FAMILY

[查询PIC24FJ256DA106供应商](#)

31.0 PACKAGING INFORMATION

31.1 Package Marking Information

64-Lead TQFP (10x10x1 mm)

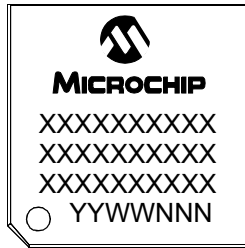

Example

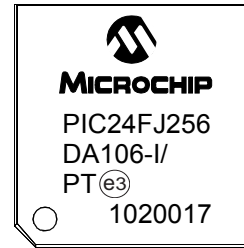

64-Lead QFN (9x9x0.9 mm)



Example



100-Lead TQFP (12x12x1 mm)

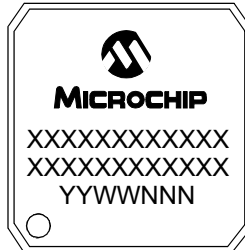

Example

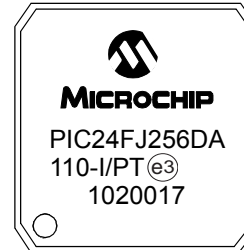

121-BGA (10x10x1.1 mm)

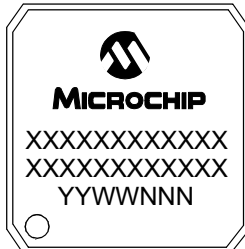

Example

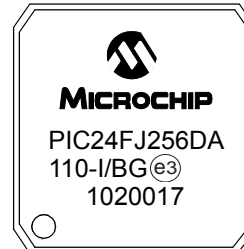

Legend: XX...X Customer-specific information
Y Year code (last digit of calendar year)
YY Year code (last 2 digits of calendar year)
WW Week code (week of January 1 is week '01')
NNN Alphanumeric traceability code
^(e3) Pb-free JEDEC designator for Matte Tin (Sn)
* This package is Pb-free. The Pb-free JEDEC designator (^(e3)) can be found on the outer packaging for this package.

Note: In the event the full Microchip part number cannot be marked on one line, it will be carried over to the next line, thus limiting the number of available characters for customer-specific information.

PIC24FJ256DA210 FAMILY

[查询PIC24FJ256DA106供应商](#)

31.2 Package Details

The following sections give the technical details of the packages.

64-Lead Plastic Thin Quad Flatpack (PT) – 10x10x1 mm Body, 2.00 mm [TQFP]

Note: For the most current package drawings, please see the Microchip Packaging Specification located at <http://www.microchip.com/packaging>

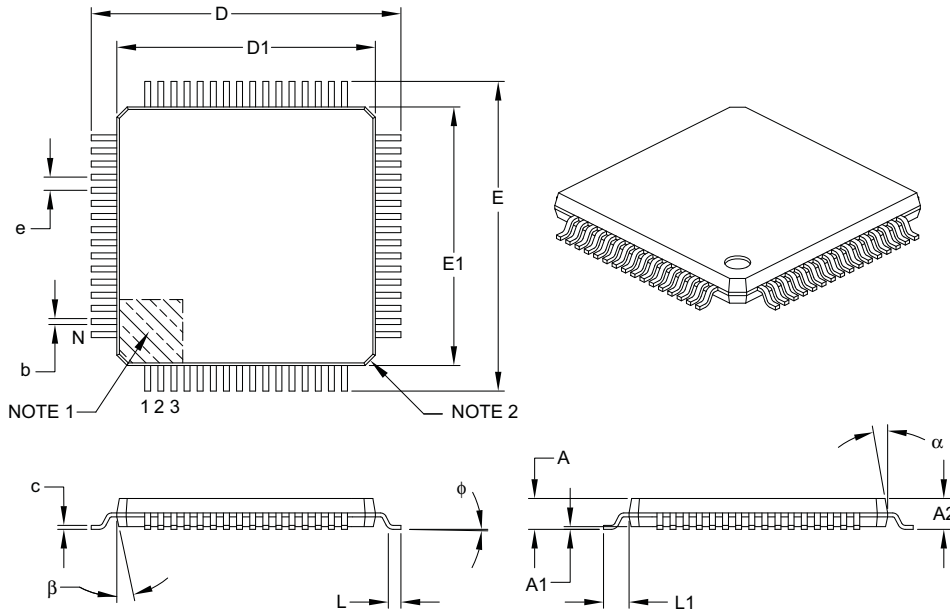

| Units | | MILLIMETERS | | |
|--------------------------|----------|-------------|------|------|
| Dimension Limits | | MIN | NOM | MAX |
| Number of Leads | N | 64 | | |
| Lead Pitch | e | 0.50 BSC | | |
| Overall Height | A | – | – | 1.20 |
| Molded Package Thickness | A2 | 0.95 | 1.00 | 1.05 |
| Standoff | A1 | 0.05 | – | 0.15 |
| Foot Length | L | 0.45 | 0.60 | 0.75 |
| Footprint | L1 | 1.00 REF | | |
| Foot Angle | ϕ | 0° | 3.5° | 7° |
| Overall Width | E | 12.00 BSC | | |
| Overall Length | D | 12.00 BSC | | |
| Molded Package Width | E1 | 10.00 BSC | | |
| Molded Package Length | D1 | 10.00 BSC | | |
| Lead Thickness | c | 0.09 | – | 0.20 |
| Lead Width | b | 0.17 | 0.22 | 0.27 |
| Mold Draft Angle Top | α | 11° | 12° | 13° |
| Mold Draft Angle Bottom | β | 11° | 12° | 13° |

Notes:

- Pin 1 visual index feature may vary, but must be located within the hatched area.
- Chamfers at corners are optional; size may vary.
- Dimensions D1 and E1 do not include mold flash or protrusions. Mold flash or protrusions shall not exceed 0.25 mm per side.
- Dimensioning and tolerancing per ASME Y14.5M.

BSC: Basic Dimension. Theoretically exact value shown without tolerances.

REF: Reference Dimension, usually without tolerance, for information purposes only.

Microchip Technology Drawing C04-085B

PIC24FJ256DA210 FAMILY

[查询PIC24FJ256DA106供应商](#)

64-Lead Plastic Thin Quad Flatpack (PT) – 10x10x1 mm Body, 2.00 mm [TQFP]

Note: For the most current package drawings, please see the Microchip Packaging Specification located at <http://www.microchip.com/packaging>

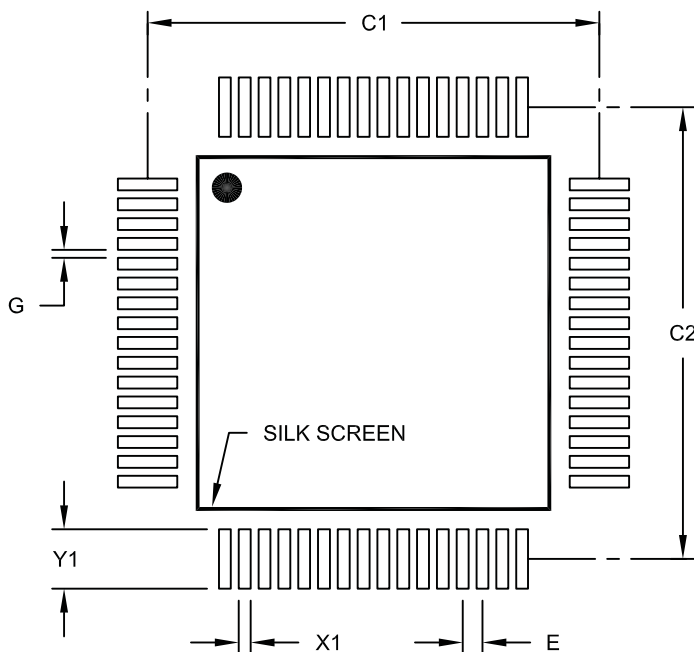

RECOMMENDED LAND PATTERN

| Units | | MILLIMETERS | | |
|--------------------------|----|-------------|-------|------|
| | | MIN | NOM | MAX |
| Dimension Limits | | | | |
| Contact Pitch | E | 0.50 BSC | | |
| Contact Pad Spacing | C1 | | 11.40 | |
| Contact Pad Spacing | C2 | | 11.40 | |
| Contact Pad Width (X64) | X1 | | | 0.30 |
| Contact Pad Length (X64) | Y1 | | | 1.50 |
| Distance Between Pads | G | 0.20 | | |

Notes:

1. Dimensioning and tolerancing per ASME Y14.5M

BSC: Basic Dimension. Theoretically exact value shown without tolerances.

Microchip Technology Drawing No. C04-2085A

PIC24FJ256DA210 FAMILY

[查询PIC24FJ256DA106供应商](#)

64-Lead Plastic Quad Flat, No Lead Package (MR) – 9x9x0.9 mm Body [QFN]

Note: For the most current package drawings, please see the Microchip Packaging Specification located at <http://www.microchip.com/packaging>

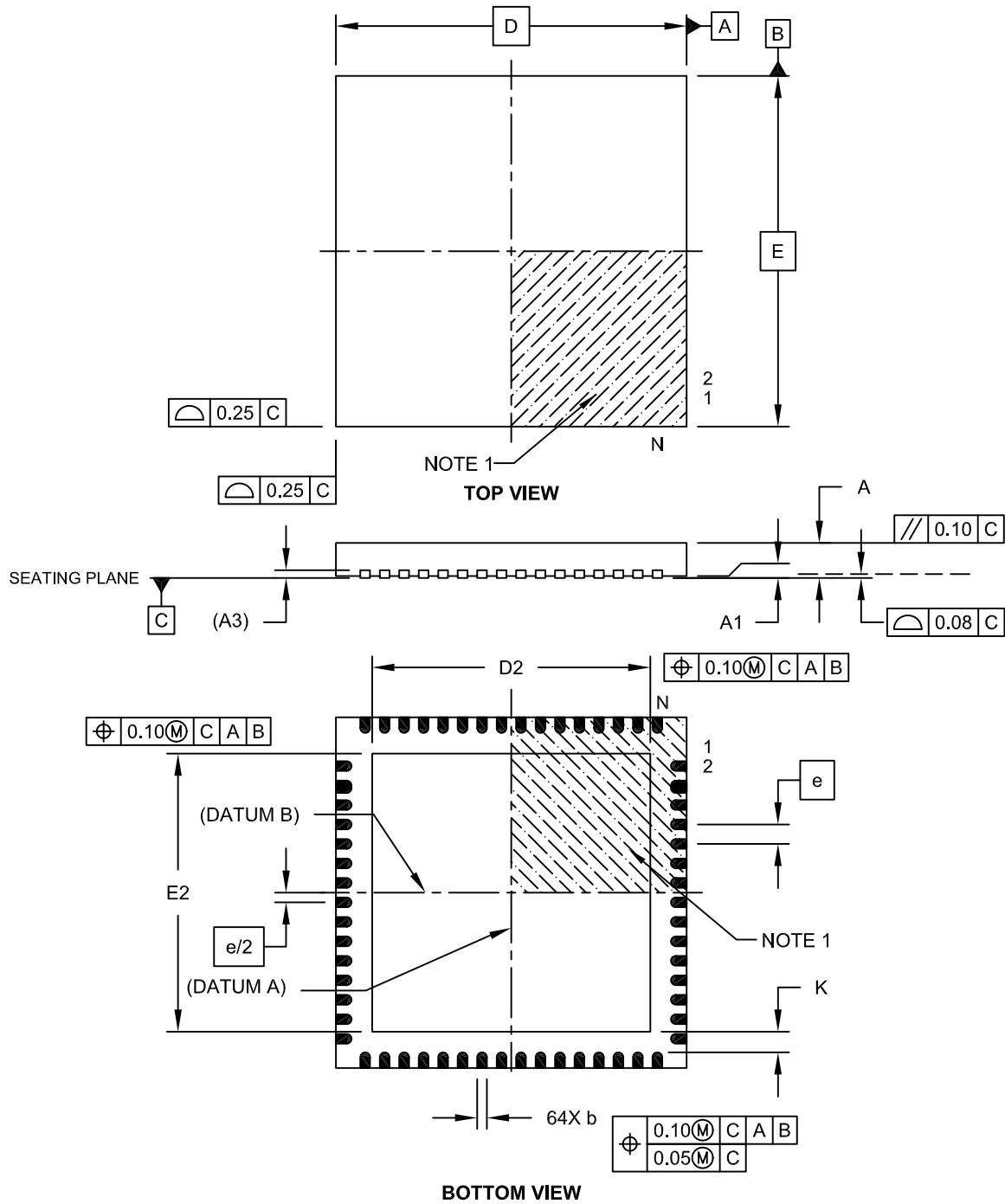

Microchip Technology Drawing C04-149B Sheet 1 of 2

PIC24FJ256DA210 FAMILY

[查询PIC24FJ256DA106供应商](#)

64-Lead Plastic Quad Flat, No Lead Package (MR) – 9x9x0.9 mm Body [QFN]

Note: For the most current package drawings, please see the Microchip Packaging Specification located at <http://www.microchip.com/packaging>

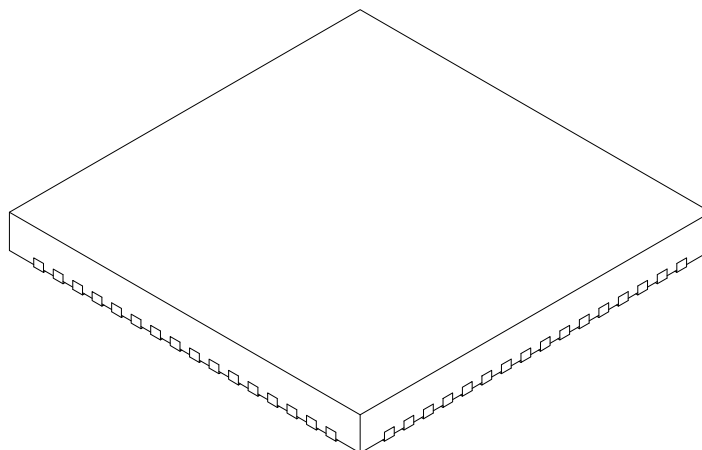

| Units | | MILLIMETERS | | |
|------------------------|----|-------------|------|------|
| | | MIN | NOM | MAX |
| Number of Pins | N | 64 | | |
| Pitch | e | 0.50 BSC | | |
| Overall Height | A | 0.80 | 0.90 | 1.00 |
| Standoff | A1 | 0.00 | 0.02 | 0.05 |
| Contact Thickness | A3 | 0.20 REF | | |
| Overall Width | E | 9.00 BSC | | |
| Exposed Pad Width | E2 | 7.05 | 7.15 | 7.50 |
| Overall Length | D | 9.00 BSC | | |
| Exposed Pad Length | D2 | 7.05 | 7.15 | 7.50 |
| Contact Width | b | 0.18 | 0.25 | 0.30 |
| Contact Length | L | 0.30 | 0.40 | 0.50 |
| Contact-to-Exposed Pad | K | 0.20 | - | - |

Notes:

1. Pin 1 visual index feature may vary, but must be located within the hatched area.
2. Package is saw singulated.
3. Dimensioning and tolerancing per ASME Y14.5M.

BSC: Basic Dimension. Theoretically exact value shown without tolerances.

REF: Reference Dimension, usually without tolerance, for information purposes only.

Microchip Technology Drawing C04-149B Sheet 2 of 2

PIC24FJ256DA210 FAMILY

[查询PIC24FJ256DA106供应商](#)

64-Lead Plastic Quad Flat, No Lead Package (MR) – 9x9x0.9 mm Body [QFN]
With 0.40 mm Contact Length

Note: For the most current package drawings, please see the Microchip Packaging Specification located at <http://www.microchip.com/packaging>

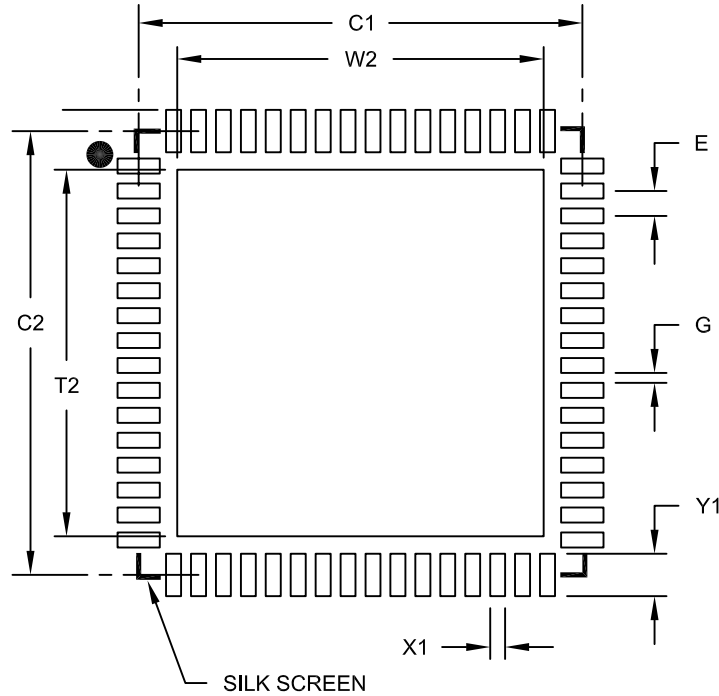

RECOMMENDED LAND PATTERN

| Dimension Limits | Units | MILLIMETERS | | |
|----------------------------|-------|-------------|------|------|
| | | MIN | NOM | MAX |
| Contact Pitch | E | 0.50 BSC | | |
| Optional Center Pad Width | W2 | | | 7.35 |
| Optional Center Pad Length | T2 | | | 7.35 |
| Contact Pad Spacing | C1 | | 8.90 | |
| Contact Pad Spacing | C2 | | 8.90 | |
| Contact Pad Width (X64) | X1 | | | 0.30 |
| Contact Pad Length (X64) | Y1 | | | 0.85 |
| Distance Between Pads | G | 0.20 | | |

Notes:

1. Dimensioning and tolerancing per ASME Y14.5M

BSC: Basic Dimension. Theoretically exact value shown without tolerances.

Microchip Technology Drawing No. C04-2149A

PIC24FJ256DA210 FAMILY

[查询PIC24FJ256DA106供应商](#)

100-Lead Plastic Thin Quad Flatpack (PT) – 12x12x1 mm Body, 2.00 mm [TQFP]

Note: For the most current package drawings, please see the Microchip Packaging Specification located at <http://www.microchip.com/packaging>

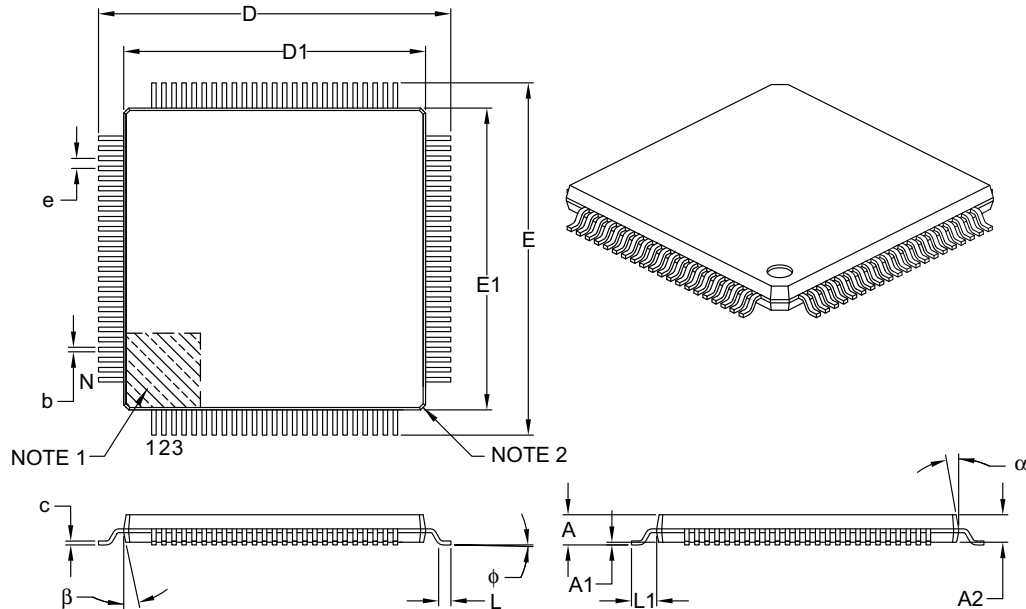

| Dimension Limits | Units | MILLIMETERS | | |
|--------------------------|-------|-------------|------|------|
| | | MIN | NOM | MAX |
| Number of Leads | N | 100 | | |
| Lead Pitch | e | 0.40 BSC | | |
| Overall Height | A | – | – | 1.20 |
| Molded Package Thickness | A2 | 0.95 | 1.00 | 1.05 |
| Standoff | A1 | 0.05 | – | 0.15 |
| Foot Length | L | 0.45 | 0.60 | 0.75 |
| Footprint | L1 | 1.00 REF | | |
| Foot Angle | φ | 0° | 3.5° | 7° |
| Overall Width | E | 14.00 BSC | | |
| Overall Length | D | 14.00 BSC | | |
| Molded Package Width | E1 | 12.00 BSC | | |
| Molded Package Length | D1 | 12.00 BSC | | |
| Lead Thickness | c | 0.09 | – | 0.20 |
| Lead Width | b | 0.13 | 0.18 | 0.23 |
| Mold Draft Angle Top | α | 11° | 12° | 13° |
| Mold Draft Angle Bottom | β | 11° | 12° | 13° |

Notes:

- Pin 1 visual index feature may vary, but must be located within the hatched area.
- Chamfers at corners are optional; size may vary.
- Dimensions D1 and E1 do not include mold flash or protrusions. Mold flash or protrusions shall not exceed 0.25 mm per side.
- Dimensioning and tolerancing per ASME Y14.5M.

BSC: Basic Dimension. Theoretically exact value shown without tolerances.

REF: Reference Dimension, usually without tolerance, for information purposes only.

Microchip Technology Drawing C04-100B

PIC24FJ256DA210 FAMILY

[查询PIC24FJ256DA106供应商](#)

100-Lead Plastic Thin Quad Flatpack (PT) – 12x12x1 mm Body, 2.00 mm [TQFP]

Note: For the most current package drawings, please see the Microchip Packaging Specification located at <http://www.microchip.com/packaging>

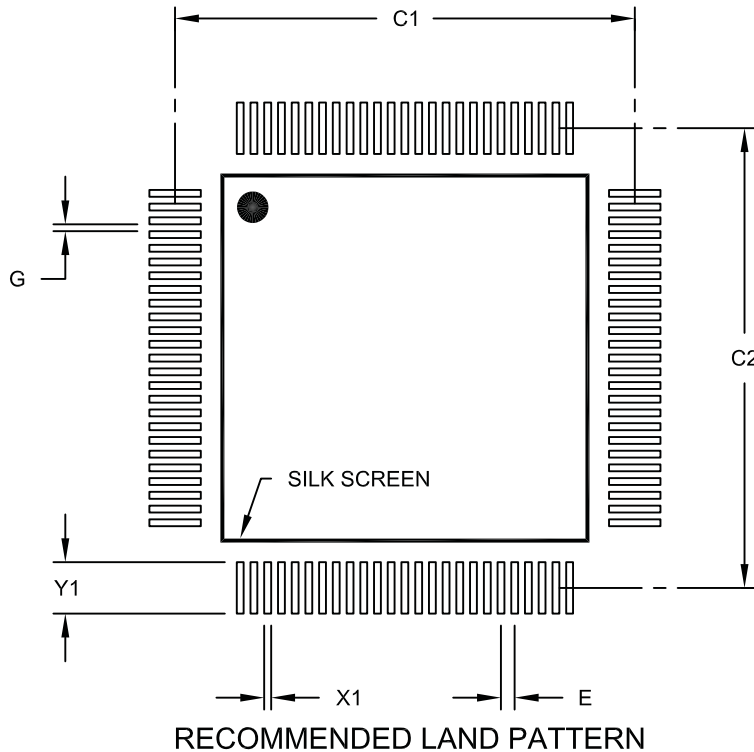

| Dimension Limits | Units | MILLIMETERS | | |
|---------------------------|-------|-------------|-------|------|
| | | MIN | NOM | MAX |
| Contact Pitch | E | 0.40 BSC | | |
| Contact Pad Spacing | C1 | | 13.40 | |
| Contact Pad Spacing | C2 | | 13.40 | |
| Contact Pad Width (X100) | X1 | | | 0.20 |
| Contact Pad Length (X100) | Y1 | | | 1.50 |
| Distance Between Pads | G | 0.20 | | |

Notes:

1. Dimensioning and tolerancing per ASME Y14.5M

BSC: Basic Dimension. Theoretically exact value shown without tolerances.

Microchip Technology Drawing No. C04-2100A

PIC24FJ256DA210 FAMILY

[查询PIC24FJ256DA106供应商](#)

121-Lead Plastic Thin Profile Ball Grid Array (BG) - 10x10x1.10 mm Body [XBGA]

Note: For the most current package drawings, please see the Microchip Packaging Specification located at <http://www.microchip.com/packaging>

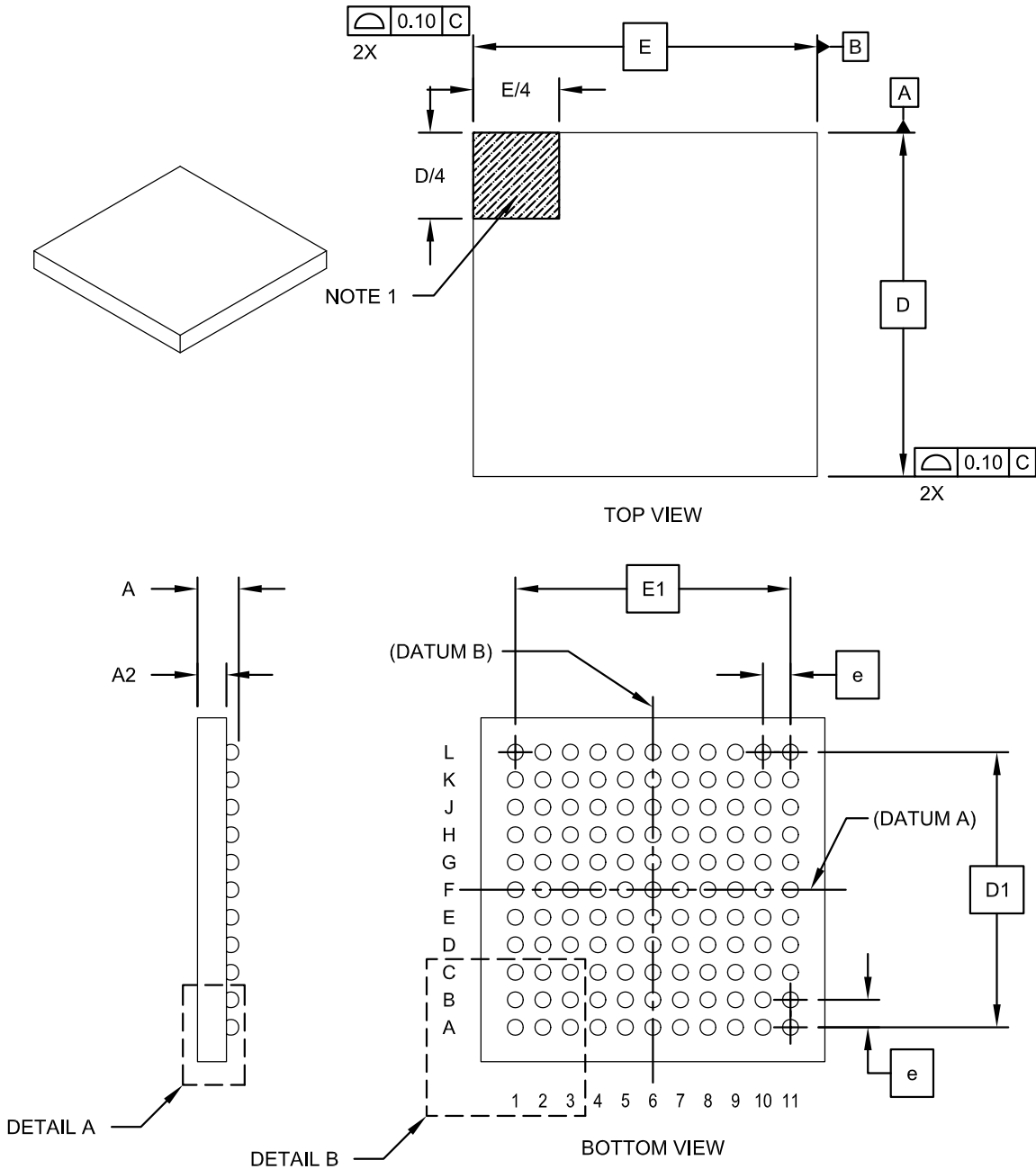

Microchip Technology Drawing C04-148A Sheet 1 of 2

PIC24FJ256DA210 FAMILY

[查询PIC24FJ256DA106供应商](#)

121-Lead Plastic Thin Profile Ball Grid Array (BG) - 10x10x1.10 mm Body [XBGA]

Note: For the most current package drawings, please see the Microchip Packaging Specification located at <http://www.microchip.com/packaging>

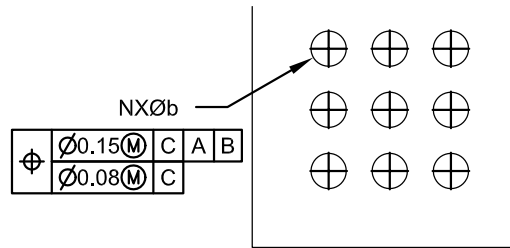
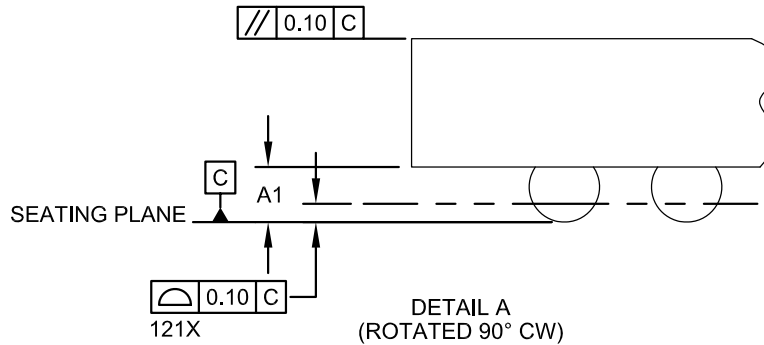

DETAIL B

| Dimension Limits | Units | MILLIMETERS | | |
|--------------------------|-------|-------------|------|------|
| | | MIN | NOM | MAX |
| Number of Contacts | N | 121 | | |
| Contact Pitch | e | 0.80 BSC | | |
| Overall Height | A | 1.00 | 1.10 | 1.20 |
| Standoff | A1 | 0.25 | 0.30 | 0.35 |
| Molded Package Thickness | A2 | 0.55 | 0.60 | 0.65 |
| Overall Width | E | 10.00 BSC | | |
| Array Width | E1 | 8.00 BSC | | |
| Overall Length | D | 10.00 BSC | | |
| Array Length | D1 | 8.00 BSC | | |
| Contact Diameter | b | 0.40 TYP | | |

Notes:

- Pin 1 visual index feature may vary, but must be located within the hatched area.
- Dimensioning and tolerancing per ASME Y14.5M.
BSC: Basic Dimension. Theoretically exact value shown without tolerances.
REF: Reference Dimension, usually without tolerance, for information purposes only.
- The outer rows and columns of balls are located with respect to datums A and B.

Microchip Technology Drawing C04-148 Rev A Sheet 2 of 2

PIC24FJ256DA210 FAMILY

[查询PIC24FJ256DA106供应商](#)

APPENDIX A: REVISION HISTORY

Revision A (February 2010)

Original data sheet for the PIC24FJ256DA210 family of devices.

Revision B (May 2010)

Minor changes throughout text and the values in **Section 30.0 “Electrical Characteristics”** were updated.

PIC24FJ256DA210 FAMILY

[查询PIC24FJ256DA106供应商](#)

NOTES:

PIC24FJ256DA210 FAMILY

[查询PIC24FJ256DA106供应商](#)

INDEX

A

| | |
|---|-----|
| A/D Conversion | |
| 10-Bit High-Speed A/D Converter | 325 |
| A/D Converter | 325 |
| Analog Input Model | 333 |
| Transfer Function | 333 |
| AC Characteristics | |
| ADC Conversion Timing | 385 |
| CLKO and I/O Timing | 383 |
| Internal RC Accuracy | 382 |
| Alternate Interrupt Vector Table (AIVT) | 93 |
| Alternative Master | |
| EPMP | 273 |
| Assembler | |
| MPASM Assembler | 360 |

B

| | |
|--|-----|
| Block Diagram | |
| CRC | 297 |
| Block Diagrams | |
| 10-Bit High-Speed A/D Converter | 326 |
| 16-Bit Asynchronous Timer3 and Timer5 | 193 |
| 16-Bit Synchronous Timer2 and Timer4 | 193 |
| 16-Bit Timer1 Module | 189 |
| 32-Bit Timer2/3 and Timer4/5 | 192 |
| 96 MHz PLL | 150 |
| Accessing Program Space Using Table Operations | 77 |
| Addressing for Table Registers | 81 |
| BDT Mapping for Endpoint Buffering Modes | 244 |
| CALL Stack Frame | 75 |
| Comparator Voltage Reference | 341 |
| CPU Programmer's Model | 41 |
| CRC Shift Engine Detail | 297 |
| CTMU Connections and Internal Configuration for Capacitance Measurement | 343 |
| CTMU Typical Connections and Internal Configuration for Pulse Delay Generation | 344 |
| CTMU Typical Connections and Internal Configuration for Time Measurement | 344 |
| Data Access From Program Space Address Generation | 76 |
| Graphics Module Overview | 305 |
| I ² C Module | 224 |
| Individual Comparator Configurations, CREF = 0 | 336 |
| Individual Comparator Configurations, CREF = 1 and CVREFP = 0 | 337 |
| Individual Comparator ConfigurationS, CREF = 1 and CVREFP = 1 | 337 |
| Input Capture | 197 |
| On-Chip Regulator Connections | 354 |
| Output Compare (16-Bit Mode) | 202 |
| Output Compare (Double-Buffered, 16-Bit PWM Mode) | 204 |
| PIC24FJ256DA210 Family (General) | 20 |
| PIC24F CPU Core | 40 |
| PSV Operation (Higher Word) | 79 |
| PSV Operation (Lower Word) | 79 |
| Reset System | 87 |
| RTCC | 285 |

| | |
|---|-----|
| Shared I/O Port Structure | 157 |
| SPI Master, Frame Master Connection | 220 |
| SPI Master, Frame Slave Connection | 220 |
| SPI Master/Slave Connection (Enhanced Buffer Modes) | 219 |
| SPI Master/Slave Connection (Standard Mode) | 219 |
| SPI Slave, Frame Master Connection | 220 |
| SPI Slave, Frame Slave Connection | 220 |
| SPIx Module (Enhanced Mode) | 213 |
| SPIx Module (Standard Mode) | 212 |
| System Clock | 141 |
| Triple Comparator Module | 335 |
| UART (Simplified) | 231 |
| USB OTG Device Mode Power Modes | 241 |
| USB OTG Interrupt Funnel | 248 |
| USB OTG Module | 240 |
| Watchdog Timer (WDT) | 356 |

C

| | |
|--|-----|
| C Compilers | |
| MPLAB C18 | 360 |
| Charge Time Measurement Unit (CTMU) | 343 |
| Key Features | 343 |
| Charge Time Measurement Unit. See CTMU. | |
| Code Examples | |
| Basic Sequence for Clock Switching in Assembly | 149 |
| Configuring UART1 I/O Input/Output Functions (PPS) | 168 |
| EDS Read From Program Memory in Assembly | 80 |
| EDS Read in Assembly | 72 |
| EDS Write in Assembly | 73 |
| Erasing a Program Memory Block (Assembly) | 84 |
| I/O Port Read/Write in 'C' | 163 |
| I/O Port Read/Write in Assembly | 163 |
| Initiating a Programming Sequence | 85 |
| PWRSAV Instruction Syntax | 155 |
| Setting the RTCWREN Bit | 286 |
| Single-Word Flash Programming | 86 |
| Single-Word Flash Programming ('C' Language) | 86 |
| Code Protection | 357 |
| Code Segment Protection | 357 |
| Configuration Options | 358 |
| Configuration Protection | 358 |
| Comparator Voltage Reference | 341 |
| Configuring | 341 |
| Configuration Bits | 347 |
| Core Features | 15 |
| CPU | |
| Arithmetic Logic Unit (ALU) | 43 |
| Control Registers | 42 |
| Core Registers | 40 |
| Programmer's Model | 39 |
| CRC | |
| 32-Bit Programmable Cyclic Redundancy Check | 297 |
| Polynomials | 298 |
| Setup Examples for 16 and 32-Bit Polynomials | 298 |
| User Interface | 298 |

PIC24FJ256DA210 FAMILY

[查询PIC24FJ256DA106供应商](#)

| | |
|--|-----|
| Measuring Capacitance | 343 |
| Measuring Time | 344 |
| Pulse Delay and Generation | 344 |
| Customer Change Notification Service | 405 |
| Customer Notification Service | 405 |
| Customer Support | 405 |

D

| | |
|-------------------------------------|-----|
| Data Memory | |
| Address Space | 47 |
| Memory Map | 48 |
| Near Data Space | 49 |
| SFR Space | 49 |
| Software Stack | 75 |
| Space Organization, Alignment | 49 |
| DC Characteristics | |
| I/O Pin Input Specifications | 377 |
| I/O Pin Output Specifications | 378 |
| Program Memory | 378 |
| Development Support | 359 |
| Device Features | |
| 100/121--Pin | 19 |
| 64-Pin | 18 |
| Doze Mode | 156 |

E

| | |
|---|-----|
| EDS | 273 |
| Electrical Characteristics | |
| A/D Specifications | 384 |
| Absolute Maximum Ratings | 371 |
| Capacitive Loading on Output Pin | 380 |
| External Clock Timing | 381 |
| Idle Current | 375 |
| Load Conditions and Requirements for Specifications | 379 |
| Operating Current | 374 |
| PLL Clock Timing Specifications | 381 |
| Power-Down Current | 376 |
| RC Oscillator Start-up Time | 382 |
| Reset and Brown-out Reset Requirements | 382 |
| Temperature and Voltage Specifications | 373 |
| Thermal Conditions | 372 |
| V/F Graph | 372 |
| Voltage Regulator Specifications | 379 |
| Enhanced Parallel Master Port. See EPMP | 273 |
| ENVREG Pin | 354 |
| EPMP | 273 |
| Alternative Master | 273 |
| Key Features | 273 |
| Master Port Pins | 274 |
| Equations | |
| 16-Bit, 32-Bit CRC Polynomials | 298 |
| A/D Conversion Clock Period | 332 |
| Baud Rate Reload Calculation | 225 |
| Calculating the PWM Period | 204 |
| Calculation for Maximum PWM Resolution | 205 |
| Estimating USB Transceiver Current Consumption | 243 |
| Relationship Between Device and SPI Clock Speed | 221 |
| RTCC Calibration | 294 |
| UART Baud Rate with BRGH = 0 | 232 |
| UART Baud Rate with BRGH = 1 | 232 |
| Errata | 14 |

F

| | |
|---------------------------------|---------|
| Flash Configuration Words | 46, 347 |
| Flash Program Memory | 81 |
| and Table Instructions | 81 |
| Enhanced ICSP Operation | 82 |
| JTAG Operation | 82 |
| Programming Algorithm | 84 |
| RTSP Operation | 82 |
| Single-Word Programming | 86 |

G

| | |
|--|-----|
| Graphics Controller (GFX) | 305 |
| Key Features | 305 |
| Graphics Controller Module (GFX) | 305 |
| Graphics Display Module | |
| Display Clock (GCLK) Source | 324 |
| Display Configuration | 324 |
| Memory Locations | 324 |
| Memory Requirements | 324 |
| Module Registers | 306 |
| Graphics Display Module (GFX) | 305 |

I

| | |
|---|-----|
| I/O Ports | |
| Analog Port Pins Configuration | 158 |
| Analog/Digital Function of an I/O Pin | 158 |
| Input Change Notification | 163 |
| Open-Drain Configuration | 158 |
| Parallel (PIO) | 157 |
| Peripheral Pin Select | 164 |
| Pull-ups and Pull-downs | 163 |
| Selectable Input Sources | 165 |

I²C

| | |
|---|-----|
| Clock Rates | 225 |
| Reserved Addresses | 225 |
| Setting Baud Rate as Bus Master | 225 |
| Slave Address Masking | 225 |
| Idle Mode | 156 |
| Input Capture | |
| 32-Bit Mode | 198 |
| Operations | 198 |
| Synchronous and Trigger Modes | 197 |
| Input Capture with Dedicated Timers | 197 |
| Input Voltage Levels for Port or Pin | |
| Tolerated Description Input | 158 |

Instruction Set

| | |
|--|----------|
| Overview | 365 |
| Summary | 363 |
| Instruction-Based Power-Saving Modes | 155, 156 |
| Interfacing Program and Data Spaces | 75 |
| Inter-Integrated Circuit. See I ² C. | 223 |
| Internet Address | 405 |
| Interrupt Vector Table (IVT) | 93 |
| Interrupts | |
| Control and Status Registers | 96 |
| Implemented Vectors | 95 |
| Reset Sequence | 93 |
| Setup and Service Procedures | 140 |
| Trap Vectors | 94 |
| Vector Table | 94 |

J

| | |
|----------------------|-----|
| JTAG Interface | 358 |
|----------------------|-----|

PIC24FJ256DA210 FAMILY

[查询PIC24FJ256DA106供应商](#)

| | |
|-------------------|-----|
| K | |
| Key Features..... | 347 |
| CTMU..... | 343 |
| EPMP..... | 273 |
| RTCC..... | 285 |

M

| | |
|--|-----|
| Memory Organization..... | 45 |
| Microchip Internet Web Site..... | 405 |
| MPLAB ASM30 Assembler, Linker, Librarian..... | 360 |
| MPLAB Integrated Development Environment Software..... | 359 |
| MPLAB PM3 Device Programmer..... | 362 |
| MPLAB REAL ICE In-Circuit Emulator System..... | 361 |
| MPLINK Object Linker/MPLIB Object Librarian..... | 360 |

N

| | |
|----------------------|----|
| Near Data Space..... | 49 |
|----------------------|----|

O

| | |
|---|-----|
| Oscillator Configuration | |
| 96 MHz PLL..... | 149 |
| Clock Selection..... | 142 |
| Clock Switching..... | 148 |
| Sequence..... | 148 |
| CPU Clocking Scheme..... | 142 |
| Display Clock Frequency Division..... | 152 |
| Initial Configuration on POR..... | 142 |
| USB Operations..... | 151 |
| Output Compare | |
| 32-Bit Mode..... | 201 |
| Synchronous and Trigger Modes..... | 201 |
| Output Compare with Dedicated Timers..... | 201 |

P

| | |
|--|-----|
| Packaging..... | 387 |
| Details..... | 388 |
| Marking..... | 387 |
| Peripheral Enable Bits..... | 156 |
| Peripheral Module Disable Bits..... | 156 |
| Peripheral Pin Select (PPS)..... | 164 |
| Available Peripherals and Pins..... | 164 |
| Configuration Control..... | 167 |
| Considerations for Use..... | 168 |
| Input Mapping..... | 164 |
| Mapping Exceptions..... | 167 |
| Output Mapping..... | 166 |
| Peripheral Priority..... | 164 |
| Registers..... | 169 |
| Pin Descriptions | |
| 100-Pin Devices..... | 8 |
| 121 (BGA)-Pin Devices..... | 11 |
| 64-Pin Devices..... | 6 |
| Pin Diagrams | |
| 100-Pin TQFP..... | 7 |
| 121-Pin BGA..... | 10 |
| 64-Pin TQFP/QFN..... | 5 |
| Pinout Descriptions..... | 21 |
| POR | |
| and On-Chip Voltage Regulator..... | 354 |
| Power-Saving | |
| Clock Frequency and Clock Switching..... | 155 |
| Features..... | 155 |
| Instruction-Based Modes..... | 155 |
| Power-up Requirements..... | 355 |
| Product Identification System..... | 407 |

| | |
|--|-----|
| Program Memory | |
| Access Using Table Instructions..... | 77 |
| Address Construction..... | 75 |
| Address Space..... | 45 |
| Flash Configuration Words..... | 46 |
| Memory Maps..... | 45 |
| Organization..... | 46 |
| Reading From Program Memory Using EDS..... | 78 |
| Pulse-Width Modulation (PWM) Mode..... | 203 |
| Pulse-Width Modulation. See PWM. | |
| PWM | |
| Duty Cycle and Period..... | 204 |

R

| | |
|--|-----|
| Reader Response..... | 406 |
| Reference Clock Output..... | 152 |
| Register Maps | |
| A/D Converter..... | 61 |
| ANCFG..... | 64 |
| ANSEL..... | 64 |
| Comparators..... | 66 |
| CPU Core..... | 50 |
| CRC..... | 66 |
| CTMU..... | 62 |
| Enhanced Parallel Master/Slave Port..... | 65 |
| Graphics..... | 69 |
| I ² C™..... | 56 |
| ICN..... | 51 |
| Input Capture..... | 54 |
| Interrupt Controller..... | 52 |
| NVM..... | 70 |
| Output Compare..... | 55 |
| Pad Configuration..... | 60 |
| Peripheral Pin Select..... | 67 |
| PMD..... | 70 |
| PORTA..... | 58 |
| PORTB..... | 58 |
| PORTC..... | 59 |
| PORTD..... | 59 |
| PORTE..... | 59 |
| PORTF..... | 60 |
| PORTG..... | 60 |
| RTCC..... | 65 |
| SPI..... | 58 |
| System..... | 70 |
| Timers..... | 53 |
| UART..... | 57 |
| USB OTG..... | 63 |

Registers

| | |
|---|-----|
| AD1CHS (A/D Input Select)..... | 330 |
| AD1CON1 (A/D Control 1)..... | 327 |
| AD1CON2 (A/D Control 2)..... | 328 |
| AD1CON3 (A/D Control 3)..... | 329 |
| AD1CSSH (A/D Input Scan Select, High)..... | 332 |
| AD1CSSL (A/D Input Scan Select, Low)..... | 331 |
| ALCFGRPT (Alarm Configuration)..... | 289 |
| ALMINSEC (Alarm Minutes and Seconds Value)..... | 293 |
| ALMTHDY (Alarm Month and Day Value)..... | 292 |
| ALWDHR (Alarm Weekday and Hours Value)..... | 293 |
| ANCFG (A/D Band Gap Reference Configuration)..... | 331 |
| ANSA (PORTA Analog Function Selection)..... | 159 |
| ANSB (PORTB Analog Function Selection)..... | 160 |
| ANSC (PORTC Analog Function Selection)..... | 160 |
| ANSD (PORTD Analog Function Selection)..... | 161 |
| ANSE (PORTE Analog Function Selection)..... | 161 |

PIC24FJ256DA210 FAMILY

[查询PIC24FJ256DA106供应商](#)

| | | | |
|--|--------|---|-----|
| ANSF (PORTF Analog Function Selection)..... | 162 | G1STAT (Graphics Control Status)..... | 310 |
| ANSG (PORTG Analog Function Selection)..... | 162 | G1VSYNC (Vertical Synchronization Control)..... | 318 |
| BDnSTAT Prototype (Buffer Descriptor n Status, CPU Mode)..... | 247 | G1W1ADRH (GPU Work Area 1 Start Address High)..... | 313 |
| BDnSTAT Prototype (Buffer Descriptor n Status, USB Mode)..... | 246 | G1W1ADRL (GPU Work Area 1 Start Address Low)..... | 313 |
| CLKDIV (Clock Divider)..... | 145 | G1W2ADRH (GPU Work Area 2 Start Address High)..... | 314 |
| CLKDIV2 (Clock Divider 2)..... | 147 | G1W2ADRL (GPU Work Area 2 Start Address Low)..... | 313 |
| CMSTAT (Comparator Status)..... | 339 | I2CxCON (I2Cx Control)..... | 226 |
| CMxCON (Comparator x Control)..... | 338 | I2CxMSK (I2Cx Slave Mode Address Mask)..... | 230 |
| CORCON (CPU Core Control)..... | 43, 98 | I2CxSTAT (I2Cx Status)..... | 228 |
| CRCCON1 (CRC Control 1)..... | 300 | ICxCON1 (Input Capture x Control 1)..... | 199 |
| CRCCON2 (CRC Control 2)..... | 301 | ICxCON2 (Input Capture x Control 2)..... | 200 |
| CRCDATH (CRC Data High)..... | 302 | IEC0 (Interrupt Enable Control 0)..... | 109 |
| CRCDATL (CRC Data Low)..... | 302 | IEC1 (Interrupt Enable Control 1)..... | 110 |
| CRCWDATH (CRC Shift High)..... | 303 | IEC2 (Interrupt Enable Control 2)..... | 112 |
| CRCWDATL (CRC Shift Low)..... | 303 | IEC3 (Interrupt Enable Control 3)..... | 113 |
| CRCXORH (CRC XOR High)..... | 302 | IEC4 (Interrupt Enable Control 4)..... | 114 |
| CRCXORL (CRC XOR Polynomial, Low Byte)..... | 301 | IEC5 (Interrupt Enable Control 5)..... | 115 |
| CTMUCON (CTMU Control)..... | 345 | IEC6 (Interrupt Enable Control 6)..... | 116 |
| CTMUICON (CTMU Current Control)..... | 346 | IFS0 (Interrupt Flag Status 0)..... | 101 |
| CVRCON (Comparator Voltage Reference Control)..... | 342 | IFS1 (Interrupt Flag Status 1)..... | 102 |
| CW1 (Flash Configuration Word 1)..... | 348 | IFS2 (Interrupt Flag Status 2)..... | 103 |
| CW2 (Flash Configuration Word 2)..... | 350 | IFS3 (Interrupt Flag Status 3)..... | 105 |
| CW3 (Flash Configuration Word 3)..... | 351 | IFS4 (Interrupt Flag Status 4)..... | 106 |
| CW4 (Flash Configuration Word 4)..... | 352 | IFS5 (Interrupt Flag Status 5)..... | 107 |
| DEVID (Device ID)..... | 353 | IFS6 (Interrupt Flag Status 6)..... | 108 |
| DEVREV (Device Revision)..... | 354 | INTCON1 (Interrupt Control 1)..... | 99 |
| G1ACTDA (Active Display Area)..... | 317 | INTCON2 (Interrupt Control 2)..... | 100 |
| G1CHRX (Character X-Coordinate Print Position)..... | 321 | INTTREG (Interrupt Controller Test)..... | 139 |
| G1CHRY (Character Y-Coordinate Print Position)..... | 322 | IPC0 (Interrupt Priority Control 0)..... | 117 |
| G1CLUT (Color Look-up Table Control)..... | 319 | IPC1 (Interrupt Priority Control 1)..... | 118 |
| G1CLUTRD (Color Look-up Table Memory Read Data)..... | 320 | IPC10 (Interrupt Priority Control 10)..... | 127 |
| G1CLUTWR (Color Look-up Table Memory Write Data)..... | 320 | IPC11 (Interrupt Priority Control 11)..... | 128 |
| G1CMDH (GPU Command High)..... | 306 | IPC12 (Interrupt Priority Control 12)..... | 129 |
| G1CMDL (GPU Command Low)..... | 306 | IPC13 (Interrupt Priority Control 13)..... | 130 |
| G1CON1 (Display Control 1)..... | 307 | IPC15 (Interrupt Priority Control 15)..... | 131 |
| G1CON2 (Display Control 2)..... | 308 | IPC16 (Interrupt Priority Control 16)..... | 132 |
| G1CON3 (Display Control 3)..... | 309 | IPC18 (Interrupt Priority Control 18)..... | 133 |
| G1DBEN (Data I/O Pad Enable)..... | 323 | IPC19 (Interrupt Priority Control 19)..... | 133 |
| G1DBLCON (Display Blanking Control)..... | 318 | IPC2 (Interrupt Priority Control 2)..... | 119 |
| G1DPADRH (Display Buffer Start Address High)..... | 315 | IPC20 (Interrupt Priority Control 20)..... | 134 |
| G1DPADRL (Display Buffer Start Address Low)..... | 315 | IPC21 (Interrupt Priority Control 21)..... | 135 |
| G1DPDPH (Display Buffer Height)..... | 316 | IPC22 (Interrupt Priority Control 22)..... | 136 |
| G1DPHT (Display Total Height)..... | 316 | IPC23 (Interrupt Priority Control 23)..... | 137 |
| G1DPW (Display Buffer Width)..... | 315 | IPC25 (Interrupt Priority Control 25)..... | 138 |
| G1DPWT (Display Total Width)..... | 316 | IPC3 (Interrupt Priority Control 3)..... | 120 |
| G1HSYNC (Horizontal Synchronization Control)..... | 317 | IPC4 (Interrupt Priority Control 4)..... | 121 |
| G1IE (GFX Interrupt Enable)..... | 311 | IPC5 (Interrupt Priority Control 5)..... | 122 |
| G1IPU (Inflate Processor Status)..... | 322 | IPC6 (Interrupt Priority Control 6)..... | 123 |
| G1IR (GFX Interrupt Status)..... | 312 | IPC7 (Interrupt Priority Control 7)..... | 124 |
| G1MRGN (Interrupt Advance)..... | 321 | IPC8 (Interrupt Priority Control 8)..... | 125 |
| G1PUH (GPU Work Area Height)..... | 314 | IPC9 (Interrupt Priority Control 9)..... | 126 |
| G1PUW (GPU Work Area Width)..... | 314 | IPCn (Interrupt Priority Control 0-23)..... | 137 |
| | | MINSEC (RTCC Minutes and Seconds Value)..... | 291 |
| | | MTHDY (RTCC Month and Day Value)..... | 290 |
| | | NVMCON (Flash Memory Control)..... | 83 |
| | | OCxCON1 (Output Compare x Control 1)..... | 206 |
| | | OCxCON2 (Output Compare x Control 2)..... | 208 |
| | | OSCCON (Oscillator Control)..... | 143 |

PIC24FJ256DA210 FAMILY

[查询PIC24FJ256DA106供应商](#)

| | | | |
|---|----------|--|-----|
| OSCTUN (FRC Oscillator Tune)..... | 146 | Revision History..... | 397 |
| PADCFG1 (Pad Configuration Control)..... | 283, 288 | RTCC | |
| PMCON1 (EPMP Control 1)..... | 275 | Alarm Configuration..... | 294 |
| PMCON2 (EPMP Control 2)..... | 276 | Calibration..... | 294 |
| PMCON3 (EPMP Control 3)..... | 277 | Key Features..... | 285 |
| PMCON4 (EPMP Control 4)..... | 278 | Register Mapping..... | 286 |
| PMCSxBS (Chip Select x Base Address)..... | 280 | S | |
| PMCSxCF (Chip Select x Configuration)..... | 279 | Selective Peripheral Power Control..... | 156 |
| PMCSxMD (Chip Select x Mode)..... | 281 | Serial Peripheral Interface (SPI)..... | 211 |
| PMSTAT (EPMP Status, Slave Mode)..... | 282 | Serial Peripheral Interface. See SPI. | |
| RCFGCAL (RTCC Calibration and Configuration).... | 287 | SFR Space..... | 49 |
| RCON (Reset Control)..... | 88 | Sleep Mode..... | 155 |
| REFOCON (Reference Oscillator Control)..... | 153 | Software Simulator (MPLAB SIM)..... | 361 |
| RPINRn (PPS Input)..... | 169–179 | Software Stack..... | 75 |
| RPORn (PPS Output)..... | 180–187 | Special Features..... | 16 |
| SPIxCON1 (SPIx Control 1)..... | 216 | SPI..... | 211 |
| SPIxCON2 (SPIx Control 2)..... | 218 | T | |
| SPIxSTAT (SPIx Status and Control)..... | 214 | Timer1..... | 189 |
| SR (ALU STATUS)..... | 42, 97 | Timer2/3 and Timer4/5..... | 191 |
| T1CON (Timer1 Control)..... | 190 | Timing Diagrams | |
| TxCON (Timer2 and Timer4 Control)..... | 194 | CLKO and I/O Timing..... | 383 |
| TyCON (Timer3 and Timer5 Control)..... | 195 | External Clock..... | 380 |
| U1ADDR (USB Address)..... | 261 | Triple Comparator..... | 335 |
| U1CNFG1 (USB Configuration 1)..... | 262 | Triple Comparator Module..... | 335 |
| U1CNFG2 (USB Configuration 2)..... | 263 | U | |
| U1CON (USB Control, Device Mode)..... | 259 | UART..... | 231 |
| U1CON (USB Control, Host Mode)..... | 260 | Baud Rate Generator (BRG)..... | 232 |
| U1EIE (USB Error Interrupt Enable)..... | 270 | IrDA Support..... | 233 |
| U1EIR (USB Error Interrupt Status)..... | 269 | Operation of \overline{UxCTS} and \overline{UxRTS} Pins..... | 233 |
| U1EPn (USB Endpoint n Control)..... | 271 | Receiving in 8-Bit or 9-Bit Data Mode..... | 233 |
| U1IE (USB Interrupt Enable)..... | 268 | Transmitting | |
| U1IR (USB Interrupt Status, Device Mode)..... | 266 | Break and Sync Sequence..... | 233 |
| U1IR (USB Interrupt Status, Host Mode)..... | 267 | in 8-Bit Data Mode..... | 233 |
| U1OTGCON (USB OTG Control)..... | 256 | Transmitting in 9-Bit Data Mode..... | 233 |
| U1OTGIE (USB OTG Interrupt Enable, Host Mode)..... | 265 | Universal Asynchronous Receiver Transmitter. See UART. | |
| U1OTGIR (USB OTG Interrupt Status, Host Mode)..... | 264 | Universal Serial Bus | |
| U1OTGSTAT (USB OTG Status)..... | 255 | Buffer Descriptors | |
| U1PWMCN USB (VBus PWM Generator Control)..... | 272 | Assignment in Different Buffering Modes..... | 245 |
| U1PWRC (USB Power Control)..... | 257 | Interrupts | |
| U1SOF (USB OTG Start-Of-Token Threshold, Host Mode)..... | 262 | and USB Transactions..... | 249 |
| U1STAT (USB Status)..... | 258 | Universal Serial Bus. See USB OTG. | |
| U1TOK (USB Token, Host Mode)..... | 261 | USB On-The-Go (OTG)..... | 16 |
| UxMODE (UARTx Mode)..... | 234 | USB OTG..... | 239 |
| UxSTA (UARTx Status and Control)..... | 236 | Buffer Descriptors and BDT..... | 244 |
| WKDYHR (RTCC Weekday and Hours Value)..... | 291 | Device Mode Operation..... | 249 |
| YEAR (RTCC Year Value)..... | 290 | DMA Interface..... | 245 |
| Resets | | Hardware | |
| BOR (Brown-out Reset)..... | 87 | Calculating | |
| Clock Source Selection..... | 90 | Transceiver Power Requirements..... | 243 |
| CM (Configuration Mismatch Reset)..... | 87 | Hardware Configuration..... | 241 |
| Delay Times..... | 91 | Device Mode..... | 241 |
| Device Times..... | 90 | External Interface..... | 243 |
| IOPUWR (Illegal Opcode Reset)..... | 87 | Host and OTG Modes..... | 242 |
| MCLR (Pin Reset)..... | 87 | VBus Voltage Generation..... | 243 |
| POR (Power-on Reset)..... | 87 | Host Mode Operation..... | 250 |
| RCON Flags Operation..... | 89 | Interrupts..... | 248 |
| SFR States..... | 90 | Operation..... | 252 |
| SWR (RESET Instruction)..... | 87 | Registers..... | 254 |
| TRAPR (Trap Conflict Reset)..... | 87 | VBus Voltage Generation..... | 243 |
| UWR (Uninitialized W Register Reset)..... | 87 | | |
| WDT (Watchdog Timer Reset)..... | 87 | | |

PIC24FJ256DA210 FAMILY

[查询PIC24FJ256DA106供应商](#)

V

| | |
|----------------------------------|-----|
| Voltage Regulator (On-Chip)..... | 354 |
| and BOR | 355 |
| Low Voltage Detection | 354 |
| Standby Mode | 355 |

W

| | |
|----------------------------|-----|
| Watchdog Timer (WDT)..... | 355 |
| Control Register..... | 356 |
| Windowed Operation | 356 |
| WWW Address | 405 |
| WWW, On-Line Support | 14 |

PIC24FJ256DA210 FAMILY

[查询PIC24FJ256DA106供应商](#)

THE MICROCHIP WEB SITE

Microchip provides online support via our WWW site at www.microchip.com. This web site is used as a means to make files and information easily available to customers. Accessible by using your favorite Internet browser, the web site contains the following information:

- **Product Support** – Data sheets and errata, application notes and sample programs, design resources, user's guides and hardware support documents, latest software releases and archived software
- **General Technical Support** – Frequently Asked Questions (FAQ), technical support requests, online discussion groups, Microchip consultant program member listing
- **Business of Microchip** – Product selector and ordering guides, latest Microchip press releases, listing of seminars and events, listings of Microchip sales offices, distributors and factory representatives

CUSTOMER CHANGE NOTIFICATION SERVICE

Microchip's customer notification service helps keep customers current on Microchip products. Subscribers will receive e-mail notification whenever there are changes, updates, revisions or errata related to a specified product family or development tool of interest.

To register, access the Microchip web site at www.microchip.com, click on Customer Change Notification and follow the registration instructions.

CUSTOMER SUPPORT

Users of Microchip products can receive assistance through several channels:

- Distributor or Representative
- Local Sales Office
- Field Application Engineer (FAE)
- Technical Support
- Development Systems Information Line

Customers should contact their distributor, representative or field application engineer (FAE) for support. Local sales offices are also available to help customers. A listing of sales offices and locations is included in the back of this document.

Technical support is available through the web site at: <http://support.microchip.com>

PIC24FJ256DA210 FAMILY

[查询PIC24FJ256DA106供应商](#)

READER RESPONSE

It is our intention to provide you with the best documentation possible to ensure successful use of your Microchip product. If you wish to provide your comments on organization, clarity, subject matter, and ways in which our documentation can better serve you, please FAX your comments to the Technical Publications Manager at (480) 792-4150.

Please list the following information, and use this outline to provide us with your comments about this document.

To: Technical Publications Manager
RE: Reader Response
Total Pages Sent _____

From: Name _____
Company _____
Address _____
City / State / ZIP / Country _____
Telephone: (_____) _____ - _____ FAX: (_____) _____ - _____

Application (optional):

Would you like a reply? ___Y ___N

Device: PIC24FJ256DA210 Family Literature Number: DS39969B

Questions:

1. What are the best features of this document?

2. How does this document meet your hardware and software development needs?

3. Do you find the organization of this document easy to follow? If not, why?

4. What additions to the document do you think would enhance the structure and subject?

5. What deletions from the document could be made without affecting the overall usefulness?

6. Is there any incorrect or misleading information (what and where)?

7. How would you improve this document?

PIC24FJ256DA210 FAMILY

[查询PIC24FJ256DA106供应商](#)

PRODUCT IDENTIFICATION SYSTEM

To order or obtain information, e.g., on pricing or delivery, refer to the factory or the listed sales office.

| | PIC | 24 | FJ | 256 | DA2 | 10 | T | - I / | PT | - XXX |
|---|-------|-------|-------|-------|-------|-------|-------|-------|-------|-------|
| Microchip Trademark | _____ | _____ | _____ | _____ | _____ | _____ | _____ | _____ | _____ | _____ |
| Architecture | _____ | _____ | _____ | _____ | _____ | _____ | _____ | _____ | _____ | _____ |
| Flash Memory Family | _____ | _____ | _____ | _____ | _____ | _____ | _____ | _____ | _____ | _____ |
| Program Memory Size (KB) | _____ | _____ | _____ | _____ | _____ | _____ | _____ | _____ | _____ | _____ |
| Product Group | _____ | _____ | _____ | _____ | _____ | _____ | _____ | _____ | _____ | _____ |
| Pin Count | _____ | _____ | _____ | _____ | _____ | _____ | _____ | _____ | _____ | _____ |
| Tape and Reel Flag (if applicable) | _____ | _____ | _____ | _____ | _____ | _____ | _____ | _____ | _____ | _____ |
| Temperature Range | _____ | _____ | _____ | _____ | _____ | _____ | _____ | _____ | _____ | _____ |
| Package | _____ | _____ | _____ | _____ | _____ | _____ | _____ | _____ | _____ | _____ |
| Pattern | _____ | _____ | _____ | _____ | _____ | _____ | _____ | _____ | _____ | _____ |

| | |
|---------------------|---|
| Architecture | 24 = 16-bit modified Harvard without DSP |
| Flash Memory Family | FJ = Flash program memory |
| Product Group | DA2 = General purpose microcontrollers with Graphics Controller and USB On-The-Go |
| Pin Count | 06 = 64-pin 10 = 100-pin (TQFP)/121-pin (BGA) |
| Temperature Range | I = -40°C to +85°C (Industrial) |
| Package | PT = 100-lead (12x12x1 mm) TQFP (Thin Quad Flatpack) PT = 64-lead, TQFP (Thin Quad Flatpack) MR = 64-lead (9x9x0.9 mm) QFN (Quad Flatpack, No Lead) BG = 121-pin BGA package |
| Pattern | Three-digit QTP, SQTP, Code or Special Requirements (blank otherwise) ES = Engineering Sample |

Examples:

- PIC24FJ128DA206-I/PT:
PIC24F device with Graphics Controller and USB On-The-Go, 128-KB program memory, 96-KB data memory, 64-pin, Industrial temp., TQFP package.
- PIC24FJ256DA110-I/PT:
PIC24F device with Graphics Controller and USB On-The-Go, 256-KB program memory, 24-KB data memory, 100-pin, Industrial temp., TQFP package.
- PIC24FJ256DA210-I/BG:
PIC24F device with Graphics Controller and USB On-The-Go, 256-KB program memory, 96-KB data memory, 121-pin, Industrial temp., BGA package.



WORLDWIDE SALES AND SERVICE

AMERICAS

Corporate Office
2355 West Chandler Blvd.
Chandler, AZ 85224-6199
Tel: 480-792-7200
Fax: 480-792-7277
Technical Support:
<http://support.microchip.com>
Web Address:
www.microchip.com

Atlanta
Duluth, GA
Tel: 678-957-9614
Fax: 678-957-1455

Boston
Westborough, MA
Tel: 774-760-0087
Fax: 774-760-0088

Chicago
Itasca, IL
Tel: 630-285-0071
Fax: 630-285-0075

Cleveland
Independence, OH
Tel: 216-447-0464
Fax: 216-447-0643

Dallas
Addison, TX
Tel: 972-818-7423
Fax: 972-818-2924

Detroit
Farmington Hills, MI
Tel: 248-538-2250
Fax: 248-538-2260

Kokomo
Kokomo, IN
Tel: 765-864-8360
Fax: 765-864-8387

Los Angeles
Mission Viejo, CA
Tel: 949-462-9523
Fax: 949-462-9608

Santa Clara
Santa Clara, CA
Tel: 408-961-6444
Fax: 408-961-6445

Toronto
Mississauga, Ontario,
Canada
Tel: 905-673-0699
Fax: 905-673-6509

ASIA/PACIFIC

Asia Pacific Office
Suites 3707-14, 37th Floor
Tower 6, The Gateway
Harbour City, Kowloon
Hong Kong
Tel: 852-2401-1200
Fax: 852-2401-3431

Australia - Sydney
Tel: 61-2-9868-6733
Fax: 61-2-9868-6755

China - Beijing
Tel: 86-10-8528-2100
Fax: 86-10-8528-2104

China - Chengdu
Tel: 86-28-8665-5511
Fax: 86-28-8665-7889

China - Chongqing
Tel: 86-23-8980-9588
Fax: 86-23-8980-9500

China - Hong Kong SAR
Tel: 852-2401-1200
Fax: 852-2401-3431

China - Nanjing
Tel: 86-25-8473-2460
Fax: 86-25-8473-2470

China - Qingdao
Tel: 86-532-8502-7355
Fax: 86-532-8502-7205

China - Shanghai
Tel: 86-21-5407-5533
Fax: 86-21-5407-5066

China - Shenyang
Tel: 86-24-2334-2829
Fax: 86-24-2334-2393

China - Shenzhen
Tel: 86-755-8203-2660
Fax: 86-755-8203-1760

China - Wuhan
Tel: 86-27-5980-5300
Fax: 86-27-5980-5118

China - Xian
Tel: 86-29-8833-7252
Fax: 86-29-8833-7256

China - Xiamen
Tel: 86-592-2388138
Fax: 86-592-2388130

China - Zhuhai
Tel: 86-756-3210040
Fax: 86-756-3210049

ASIA/PACIFIC

India - Bangalore
Tel: 91-80-3090-4444
Fax: 91-80-3090-4123

India - New Delhi
Tel: 91-11-4160-8631
Fax: 91-11-4160-8632

India - Pune
Tel: 91-20-2566-1512
Fax: 91-20-2566-1513

Japan - Yokohama
Tel: 81-45-471-6166
Fax: 81-45-471-6122

Korea - Daegu
Tel: 82-53-744-4301
Fax: 82-53-744-4302

Korea - Seoul
Tel: 82-2-554-7200
Fax: 82-2-558-5932 or
82-2-558-5934

Malaysia - Kuala Lumpur
Tel: 60-3-6201-9857
Fax: 60-3-6201-9859

Malaysia - Penang
Tel: 60-4-227-8870
Fax: 60-4-227-4068

Philippines - Manila
Tel: 63-2-634-9065
Fax: 63-2-634-9069

Singapore
Tel: 65-6334-8870
Fax: 65-6334-8850

Taiwan - Hsin Chu
Tel: 886-3-6578-300
Fax: 886-3-6578-370

Taiwan - Kaohsiung
Tel: 886-7-536-4818
Fax: 886-7-536-4803

Taiwan - Taipei
Tel: 886-2-2500-6610
Fax: 886-2-2508-0102

Thailand - Bangkok
Tel: 66-2-694-1351
Fax: 66-2-694-1350

EUROPE

Austria - Wels
Tel: 43-7242-2244-39
Fax: 43-7242-2244-393

Denmark - Copenhagen
Tel: 45-4450-2828
Fax: 45-4485-2829

France - Paris
Tel: 33-1-69-53-63-20
Fax: 33-1-69-30-90-79

Germany - Munich
Tel: 49-89-627-144-0
Fax: 49-89-627-144-44

Italy - Milan
Tel: 39-0331-742611
Fax: 39-0331-466781

Netherlands - Drunen
Tel: 31-416-690399
Fax: 31-416-690340

Spain - Madrid
Tel: 34-91-708-08-90
Fax: 34-91-708-08-91

UK - Wokingham
Tel: 44-118-921-5869
Fax: 44-118-921-5820