

BATTERY PROTECTION IC FOR 1-CELL PACK

www.sii-ic.com

© Seiko Instruments Inc., 2009-2010

Rev.2.0_00

The S-8211E Series has the high-accuracy voltage detection circuit and the delay circuit.

This IC is suitable for monitoring overcharge and overdischarge of 1-cell lithium ion / lithium polymer secondary battery pack.

■ Features

- | | | |
|---|--|--|
| (1) High-accuracy voltage detection circuit | | |
| • Overcharge detection voltage | 3.6 V to 4.4 V (5 mV step) | Accuracy ± 25 mV (+25°C)
Accuracy ± 30 mV (-5°C to +55°C) |
| • Overcharge release voltage | 3.5 V to 4.4 V ^{*1} | Accuracy ± 50 mV |
| • Overdischarge detection voltage | 2.0 V to 3.0 V (10 mV step) | Accuracy ± 50 mV |
| • Overdischarge release voltage | 2.0 V to 3.4 V ^{*2} | Accuracy ± 100 mV |
| (2) Detection delay times are generated by an internal circuit
(external capacitors are unnecessary) | | Accuracy $\pm 20\%$ |
| (3) Wide operating temperature range | -40°C to +85°C | |
| (4) Low current consumption | | |
| • Operation mode | 3.0 μ A typ., 5.5 μ A max. (+25°C) | |
| • Overdischarge mode | 2.0 μ A typ., 3.5 μ A max. (+25°C) | |
| (5) Lead-free, Sn 100%, halogen-free ^{*3} | | |

*1. Overcharge release voltage = Overcharge detection voltage – Overcharge hysteresis voltage
(Overcharge hysteresis voltage can be selected as 0 V or from a range of 0.1 V to 0.4 V in 50 mV step.)

*2. Overdischarge release voltage = Overdischarge detection voltage + Overdischarge hysteresis voltage
(Overdischarge hysteresis voltage can be selected as 0 V or from a range of 0.1 V to 0.7 V in 100 mV step.)

*3. Refer to “**Product Name Structure**” for details.

■ Applications

- Lithium-ion rechargeable battery packs
- Lithium-polymer rechargeable battery packs

■ Packages

- SOT-23-5
- SNT-6A

■ Block Diagram

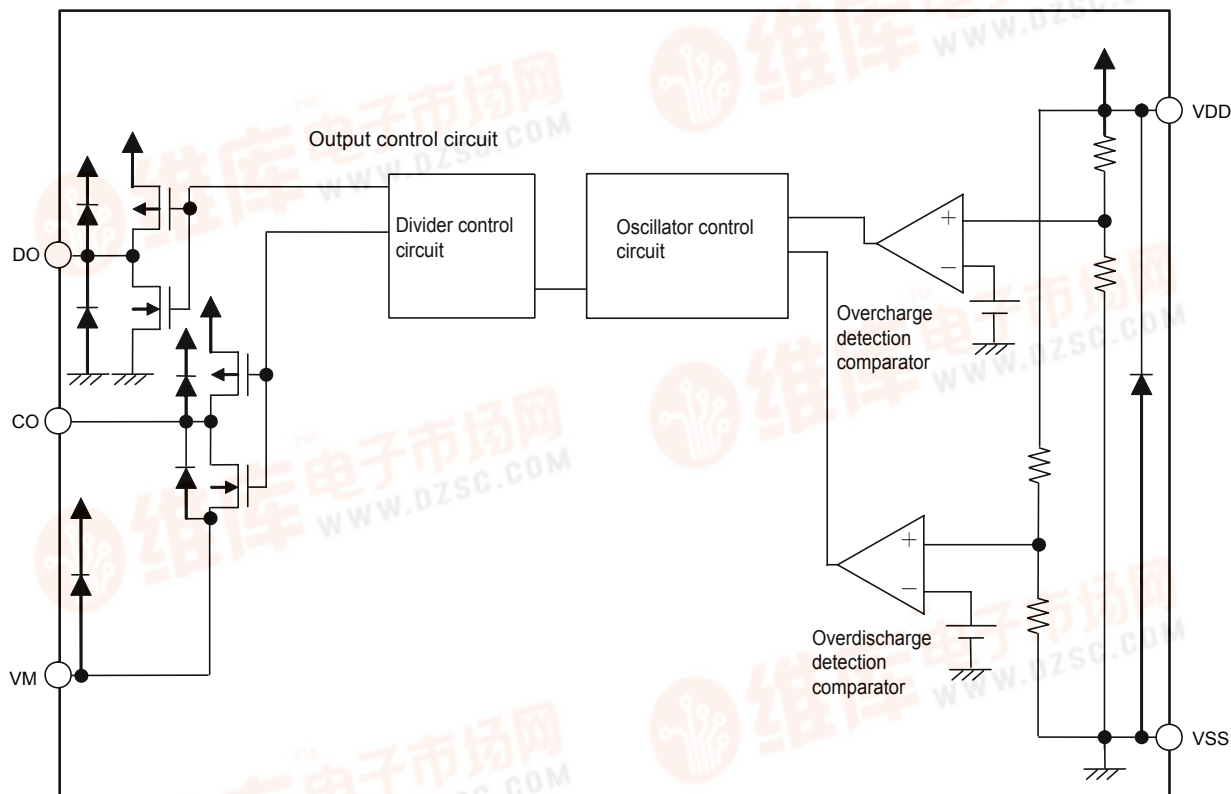

Remark All diodes shown in figure are parasitic diodes.

Figure 1



■ Product Name Structure

1. Product Name

(1) SOT-23-5

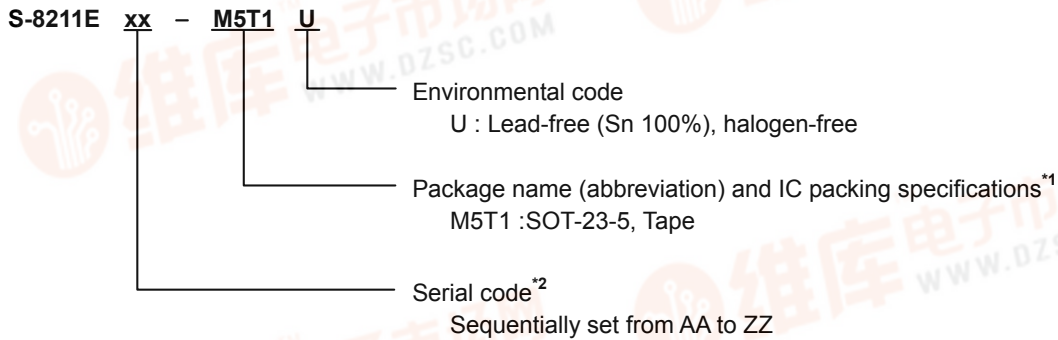

*1. Refer to the tape specifications.

*2. Refer to the "3. Product Name List".

(2) SNT-6A

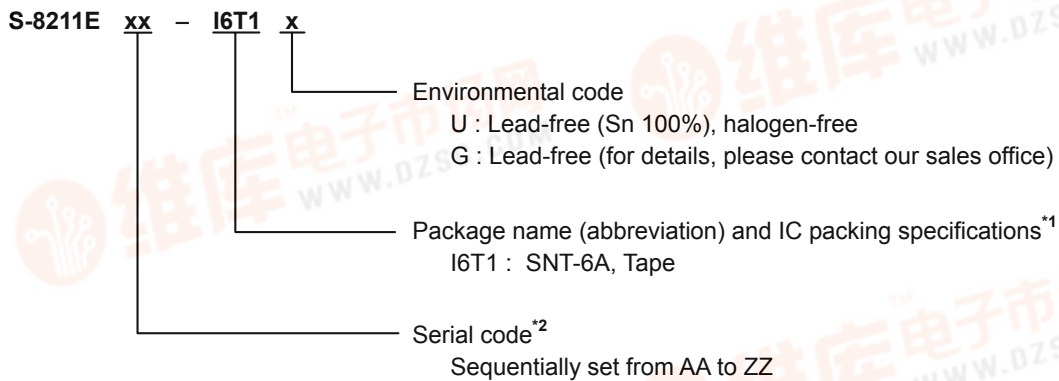

*1. Refer to the tape specifications.

*2. Refer to the "3. Product Name List".

2. Package

Package Name	Drawing Code			
	Package	Tape	Reel	Land
SOT-23-5	MP005-A-P-SD	MP005-A-C-SD	MP005-A-R-SD	-
SNT-6A	PG006-A-P-SD	PG006-A-C-SD	PG006-A-R-SD	PG006-A-L-SD

3. Product Name List

(1) SOT-23-5

Table 1

Product Name / Item	Overcharge Detection Voltage [V _{CU}]	Overcharge Release Voltage [V _{CL}]	Over-discharge Detection Voltage [V _{DL}]	Over-discharge Release Voltage [V _{DU}]	Delay Time Combination*1
S-8211EAC-M5T1U	3.600 V	3.600 V	2.00 V	2.00 V	(1)

*1. Refer to the Table 3 about the details of the delay time combinations (1).

- Remark 1.** Please contact our sales office for the products with detection voltage value other than those specified above.
2. Please select products of environmental code = U for Sn 100%, halogen-free products.

(2) SNT-6A

Table 2

Product Name / Item	Overcharge Detection Voltage [V _{CU}]	Overcharge Release Voltage [V _{CL}]	Over-discharge Detection Voltage [V _{DL}]	Over-discharge Release Voltage [V _{DU}]	Delay Time Combination*1
S-8211EAA-I6T1x	4.220 V	4.220 V	2.00 V	2.00 V	(2)
S-8211EAB-I6T1x	4.270 V	4.270 V	2.00 V	2.00 V	(2)
S-8211EAD-I6T1x	4.220 V	4.220 V	2.50 V	2.50 V	(2)
S-8211EAE-I6T1x	4.220 V	4.220 V	2.30 V	2.30 V	(2)

*1. Refer to the Table 3 about the details of the delay time combinations (2).

- Remark 1.** Please contact our sales office for the products with detection voltage value other than those specified above.
2. x: G or U
3. Please select products of environmental code = U for Sn 100%, halogen-free products.

Table 3

Delay Time Combination	Overcharge Detection Delay Time [t _{CU}]	Overdischarge Detection Delay Time [t _{DL}]
(1)	1.2 s	150 ms
(2)	573 ms	300 ms

Remark The delay times can be changed within the range listed Table 4. For details, please contact our sales office.

Table 4

Delay Time	Symbol	Selection Range			Remark
Overcharge detection delay time	t _{CU}	143 ms	573 ms	1.2 s	Select a value from the left.
Overdischarge detection delay time	t _{DL}	38 ms	150 ms	300 ms	Select a value from the left.

Remark The value surrounded by bold lines is the delay time of the standard products.



■ Pin Configurations

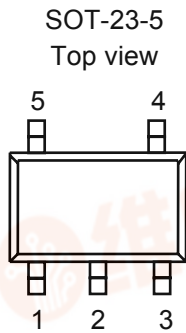

Figure 2

Table 5

Pin No.	Symbol	Description
1	VM	Negative power supply for CO pin
2	VDD	Connection for positive power supply input
3	VSS	Connection for negative power supply input
4	DO	Connection for overdischarge detection output (CMOS output)
5	CO	Connection for overcharge detection output (CMOS output)

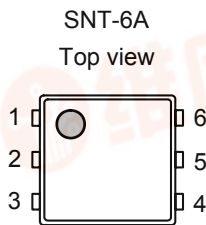

Figure 3

Table 6

Pin No.	Symbol	Description
1	NC*1	No connection
2	CO	Connection for overcharge detection output (CMOS output)
3	DO	Connection for overdischarge detection output (CMOS output)
4	VSS	Connection for negative power supply input
5	VDD	Connection for positive power supply input
6	VM	Negative power supply for CO pin

*1. The NC pin is electrically open.
The NC pin can be connected to VDD or VSS.

■ Absolute Maximum Ratings

Table 7

(Ta = 25°C unless otherwise specified)

Item	Symbol	Applied pin	Absolute Maximum Ratings	Unit
Input voltage between VDD pin and VSS pin	V _{DS}	VDD	V _{SS} - 0.3 to V _{SS} + 12	V
VM pin input voltage	V _{VM}	VM	V _{DD} - 28 to V _{DD} + 0.3	V
DO pin output voltage	V _{DO}	DO	V _{SS} - 0.3 to V _{DD} + 0.3	V
CO pin output voltage	V _{CO}	CO	V _{VM} - 0.3 to V _{DD} + 0.3	V
Power dissipation	SOT-23-5	P _D	600 ^{*1}	mW
	SNT-6A		400 ^{*1}	mW
Operating ambient temperature	T _{opr}	-	- 40 to + 85	°C
Storage temperature	T _{stg}	-	- 55 to + 125	°C

*1. When mounted on board
[Mounted board]

- (1) Board size: 114.3 mm × 76.2 mm × t1.6 mm
- (2) Board name: JEDEC STANDARD51-7

Caution The absolute maximum ratings are rated values exceeding which the product could suffer physical damage. These values must therefore not be exceeded under any conditions.

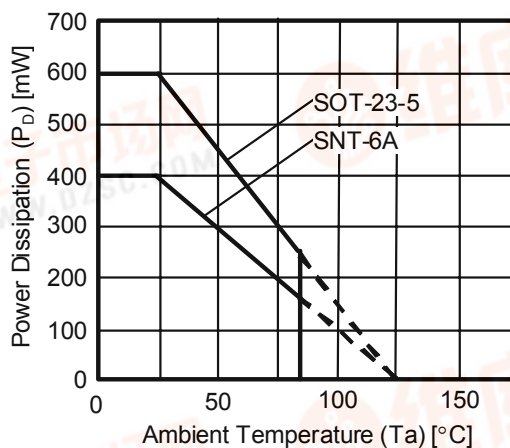

Figure 4 Power Dissipation of Package (When Mounted on Board)



■ Electrical Characteristics

1. Except Detection Delay Time (25°C)

Table 8

(Ta = 25°C unless otherwise specified)

Item	Symbol	Condition	Min.	Typ.	Max.	Unit	Test Condition	Test Circuit	
DETECTION VOLTAGE									
Overcharge detection voltage	V _{CU}	3.60 V to 4.40 V, Adjustable	V _{CU} -0.025	V _{CU}	V _{CU} +0.025	V	1	1	
		3.60 V to 4.40 V, Adjustable, Ta = -5°C to +55°C*1	V _{CU} -0.03	V _{CU}	V _{CU} +0.03	V	1	1	
Overcharge release voltage	V _{CL}	3.50 V to 4.40 V, Adjustable	V _{CL} ≠ V _{CU}	V _{CL} -0.05	V _{CL}	V _{CL} +0.05	V	1	1
			V _{CL} = V _{CU}	V _{CL} -0.05	V _{CL}	V _{CL} +0.025	V	1	1
Overdischarge detection voltage	V _{DL}	2.00 V to 3.00 V, Adjustable	V _{DL} -0.05	V _{DL}	V _{DL} +0.05	V	2	2	
Overdischarge release voltage	V _{DU}	2.00 V to 3.40 V, Adjustable	V _{DU} ≠ V _{DL}	V _{DU} -0.10	V _{DU}	V _{DU} +0.10	V	2	2
			V _{DU} = V _{DL}	V _{DU} -0.05	V _{DU}	V _{DU} +0.05	V	2	2
INPUT VOLTAGE									
Operating voltage between VDD pin and VSS pin	V _{DSOP1}	—	1.5	—	8	V	—	—	
INPUT CURRENT									
Current consumption during operation	I _{OPE}	V _{DD} = 3.5 V, V _{VM} = 0 V	1.0	3.0	5.5	μA	3	2	
Current consumption during overdischarge	I _{OPEd}	V _{DD} = 1.5 V, V _{VM} = 0 V	0.3	2.0	3.5	μA	3	2	
OUTPUT RESISTANCE									
CO pin resistance "H"	R _{COH}	V _{CO} = 3.0 V, V _{DD} = 3.5 V, V _{VM} = 0 V	2.5	5	10	kΩ	4	3	
CO pin resistance "L"	R _{COL}	V _{CO} = 0.5 V, V _{DD} = 4.5 V, V _{VM} = 0 V	2.5	5	10	kΩ	4	3	
DO pin resistance "H"	R _{DOH}	V _{DO} = 3.0 V, V _{DD} = 3.5 V, V _{VM} = 0 V	2.5	5	10	kΩ	5	3	
DO pin resistance "L"	R _{DOL}	V _{DO} = 0.5 V, V _{DD} = 1.8 V, V _{VM} = 0 V	2.5	5	10	kΩ	5	3	

*1. Since products are not screened at high and low temperature, the specification for this temperature range is guaranteed by design, not tested in production.

2. Except Detection Delay Time (−40°C to +85°C *1)

Table 9

(Ta = −40°C to +85°C *1 unless otherwise specified)

Item	Symbol	Condition	Min.	Typ.	Max.	Unit	Test Condition	Test Circuit
DETECTION VOLTAGE								
Overcharge detection voltage	V _{CU}	3.60 V to 4.40 V, Adjustable	V _{CU} − 0.060	V _{CU}	V _{CU} + 0.040	V	1	1
Overcharge release voltage	V _{CL}	3.50 V to 4.40 V, Adjustable	V _{CL} ≠ V _{CU}	V _{CL} − 0.08	V _{CL} + 0.065	V	1	1
			V _{CL} = V _{CU}	V _{CL} − 0.08	V _{CL} + 0.04	V	1	1
Overdischarge detection voltage	V _{DL}	2.00 V to 3.00 V, Adjustable	V _{DL} − 0.11	V _{DL}	V _{DL} + 0.13	V	2	2
Overdischarge release voltage	V _{DU}	2.00 V to 3.40 V, Adjustable	V _{DU} ≠ V _{DL}	V _{DU} − 0.15	V _{DU} + 0.19	V	2	2
			V _{DU} = V _{DL}	V _{DU} − 0.11	V _{DU} + 0.13	V	2	2
INPUT VOLTAGE								
Operating voltage between VDD pin and VSS pin	V _{DSOP1}	—	1.5	—	8	V	—	—
INPUT CURRENT								
Current consumption during operation	I _{OPE}	V _{DD} = 3.5 V, V _{VM} = 0 V	0.7	3.0	6.0	μA	3	2
Current consumption during overdischarge	I _{OPED}	V _{DD} = 1.5 V, V _{VM} = 0 V	0.2	2.0	3.8	μA	3	2
OUTPUT RESISTANCE								
CO pin resistance "H"	R _{COH}	V _{CO} = 3.0 V, V _{DD} = 3.5 V, V _{VM} = 0 V	1.2	5	15	kΩ	4	3
CO pin resistance "L"	R _{COL}	V _{CO} = 0.5 V, V _{DD} = 4.5 V, V _{VM} = 0 V	1.2	5	15	kΩ	4	3
DO pin resistance "H"	R _{DOH}	V _{DO} = 3.0 V, V _{DD} = 3.5 V, V _{VM} = 0 V	1.2	5	15	kΩ	5	3
DO pin resistance "L"	R _{DOL}	V _{DO} = 0.5 V, V _{DD} = 1.8 V, V _{VM} = 0 V	1.2	5	15	kΩ	5	3

*1. Since products are not screened at high and low temperature, the specification for this temperature range is guaranteed by design, not tested in production.



3. Detection Delay Time

(1) S-8211EAC

Table 10

Item	Symbol	Condition	Min.	Typ.	Max.	Unit	Test Condition	Test Circuit
DELAY TIME (Ta = 25°C)								
Overcharge detection delay time	t _{CU}	–	0.96	1.2	1.4	s	6	4
Overdischarge detection delay time	t _{DL}	–	120	150	180	ms	6	4
DELAY TIME (Ta = –40°C to +85°C) *1								
Overcharge detection delay time	t _{CU}	–	0.7	1.2	2.0	s	6	4
Overdischarge detection delay time	t _{DL}	–	83	150	255	ms	6	4

*1. Since products are not screened at high and low temperature, the specification for this temperature range is guaranteed by design, not tested in production.

(2) S-8211EAA, S-8211EAB, S-8211EAD, S-8211EAE

Table 11

Item	Symbol	Condition	Min.	Typ.	Max.	Unit	Test Condition	Test Circuit
DELAY TIME (Ta = 25°C)								
Overcharge detection delay time	t _{CU}	–	458	573	687	ms	6	4
Overdischarge detection delay time	t _{DL}	–	240	300	360	ms	6	4
DELAY TIME (Ta = –40°C to +85°C) *1								
Overcharge detection delay time	t _{CU}	–	334	573	955	ms	6	4
Overdischarge detection delay time	t _{DL}	–	166	300	510	ms	6	4

*1. Since products are not screened at high and low temperature, the specification for this temperature range is guaranteed by design, not tested in production.

■ Test Circuits

Caution Unless otherwise specified, the output voltage levels “H” and “L” at CO pin (V_{CO}) and DO pin (V_{DO}) are judged by the threshold voltage (1.0 V) of the N-channel FET. Judge the CO pin level with respect to V_{VM} and the DO pin level with respect to V_{SS} .

(1) Overcharge Detection Voltage, Overcharge Release Voltage (Test Condition 1, Test Circuit 1)

Overcharge detection voltage (V_{CU}) is defined as the voltage between the VDD pin and VSS pin at which V_{CO} goes from “H” to “L” when the voltage V_1 is gradually increased from the starting condition of $V_1 = 3.5$ V. Overcharge release voltage (V_{CL}) is defined as the voltage between the VDD pin and VSS pin at which V_{CO} goes from “L” to “H” when the voltage V_1 is then gradually decreased. Overcharge hysteresis voltage (V_{HC}) is defined as the difference between overcharge detection voltage (V_{CU}) and overcharge release voltage (V_{CL}).

(2) Overdischarge Detection Voltage, Overdischarge Release Voltage (Test Condition 2, Test Circuit 2)

Overdischarge detection voltage (V_{DL}) is defined as the voltage between the VDD pin and VSS pin at which V_{DO} goes from “H” to “L” when the voltage V_1 is gradually decreased from the starting condition of $V_1 = 3.5$ V, $V_2 = 0$ V. Overdischarge release voltage (V_{DU}) is defined as the voltage between the VDD pin and VSS pin at which V_{DO} goes from “L” to “H” when the voltage V_1 is then gradually increased. Overdischarge hysteresis voltage (V_{HD}) is defined as the difference between overdischarge release voltage (V_{DU}) and overdischarge detection voltage (V_{DL}).

(3) Operating Current Consumption (Test Condition 3, Test Circuit 2)

The operating current consumption (I_{OPE}) is the current that flows through the VDD pin (I_{DD}) under the set conditions of $V_1 = 3.5$ V and $V_2 = 0$ V (normal status).

(4) Overdischarge Current Consumption (Test Condition 3, Test Circuit 2)

The overdischarge current consumption (I_{OPED}) is the current that flows through the VDD pin (I_{DD}) under the set conditions of $V_1 = 1.5$ V, $V_2 = 0$ V (overdischarge status).

(5) CO Pin Resistance “H” (Test Condition 4, Test Circuit 3)

The CO pin resistance “H” (R_{COH}) is the resistance at the CO pin under the set conditions of $V_1 = 3.5$ V, $V_2 = 0$ V, $V_3 = 3.0$ V.

(6) CO Pin Resistance “L” (Test Condition 4, Test Circuit 3)

The CO pin resistance “L” (R_{COL}) is the resistance at the CO pin under the set conditions of $V_1 = 4.5$ V, $V_2 = 0$ V, $V_3 = 0.5$ V.

(7) DO Pin Resistance “H” (Test Condition 5, Test Circuit 3)

The DO pin H resistance (R_{DOH}) is the resistance at the DO pin under the set conditions of $V_1 = 3.5$ V, $V_2 = 0$ V, $V_4 = 3.0$ V.

(8) DO Pin Resistance “L” (Test Condition 5, Test Circuit 3)

The DO pin L resistance (R_{DOL}) is the resistance at the DO pin under the set conditions of $V_1 = 1.8$ V, $V_2 = 0$ V, $V_4 = 0.5$ V.



(9) Overcharge Detection Delay Time
(Test Condition 6, Test Circuit 4)

The overcharge detection delay time (t_{CU}) is the time needed for V_{CO} to change from "H" to "L" just after the voltage V_1 momentarily increases (within 10 μ s) from overcharge detection voltage (V_{CU}) -0.2 V to overcharge detection voltage (V_{CU}) +0.2 V under the set conditions of $V_2 = 0$ V.

(10) Overdischarge Detection Delay Time
(Test Condition 6, Test Circuit 4)

The overdischarge detection delay time (t_{DL}) is the time needed for V_{DO} to change from "H" to "L" just after the voltage V_1 momentarily decreases (within 10 μ s) from overdischarge detection voltage (V_{DL}) +0.2 V to overdischarge detection voltage (V_{DL}) -0.2 V under the set condition of $V_2 = 0$ V.

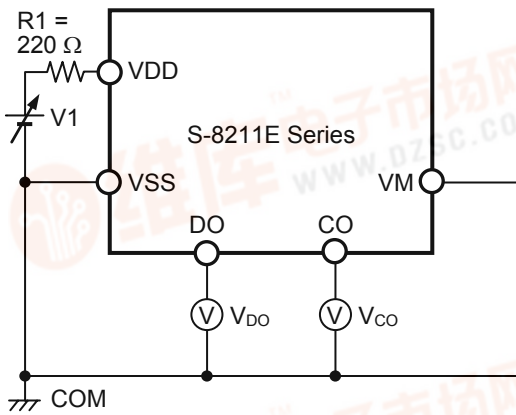

Figure 5 Test Circuit 1

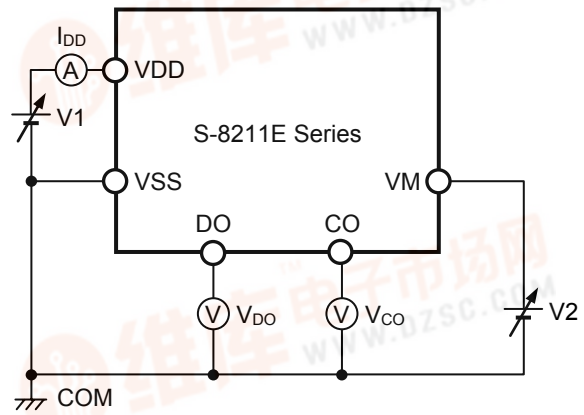

Figure 6 Test Circuit 2

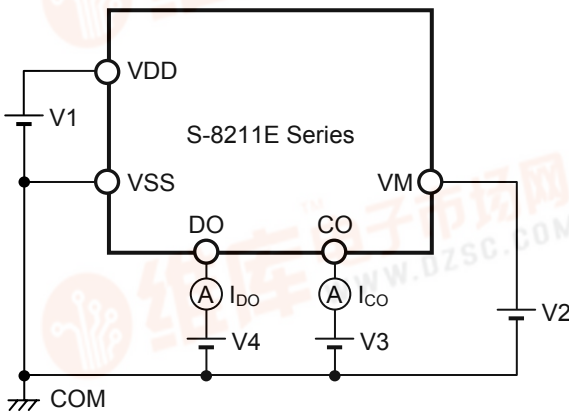

Figure 7 Test Circuit 3

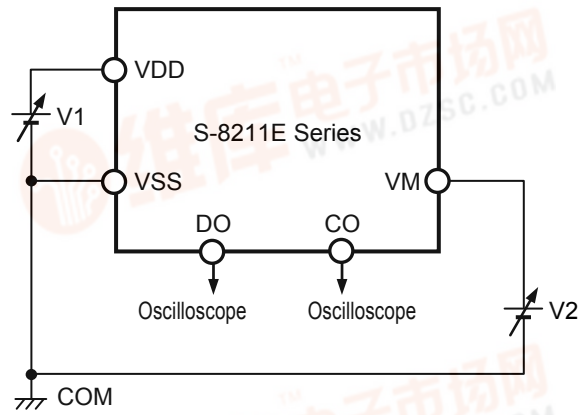

Figure 8 Test Circuit 4

■ Operation

Remark Refer to the “■ Battery Protection IC Connection Example”.

1. Normal Status

This IC monitors the voltage of the battery connected between the VDD and VSS pins. The CO and DO pins output the V_{DD} potential when the battery voltage is overdischarge detection voltage (V_{DL}) or more and overcharge detection voltage (V_{CU}) or less. This is the normal status.

2. Overcharge Status

When the battery voltage in the normal status exceeds the overcharge detection voltage (V_{CU}) during charge, and this status is held for the overcharge detection delay time (t_{CU}) or more, the CO pin outputs the V_M potential. This is the overcharge status.

This overcharge status is released when the battery voltage decreases to the overcharge release voltage (V_{CL}) or less.

3. Overdischarge Status

When the battery voltage in the normal status decreases than the overcharge detection voltage (V_{DL}) during discharge, and this status is held for the overdischarge detection delay time (t_{DL}) or more, the DO pin outputs the V_{SS} potential. This is the overdischarge status.

This overdischarge status is released when the battery voltage increases to the overdischarge release voltage (V_{DU}) or more.

4. Delay Circuit

The detection delay times are determined by dividing a clock of approximately 3.5 kHz by the counter.



■ Timing Chart

(1) Overcharge Detection, Overdischarge Detection

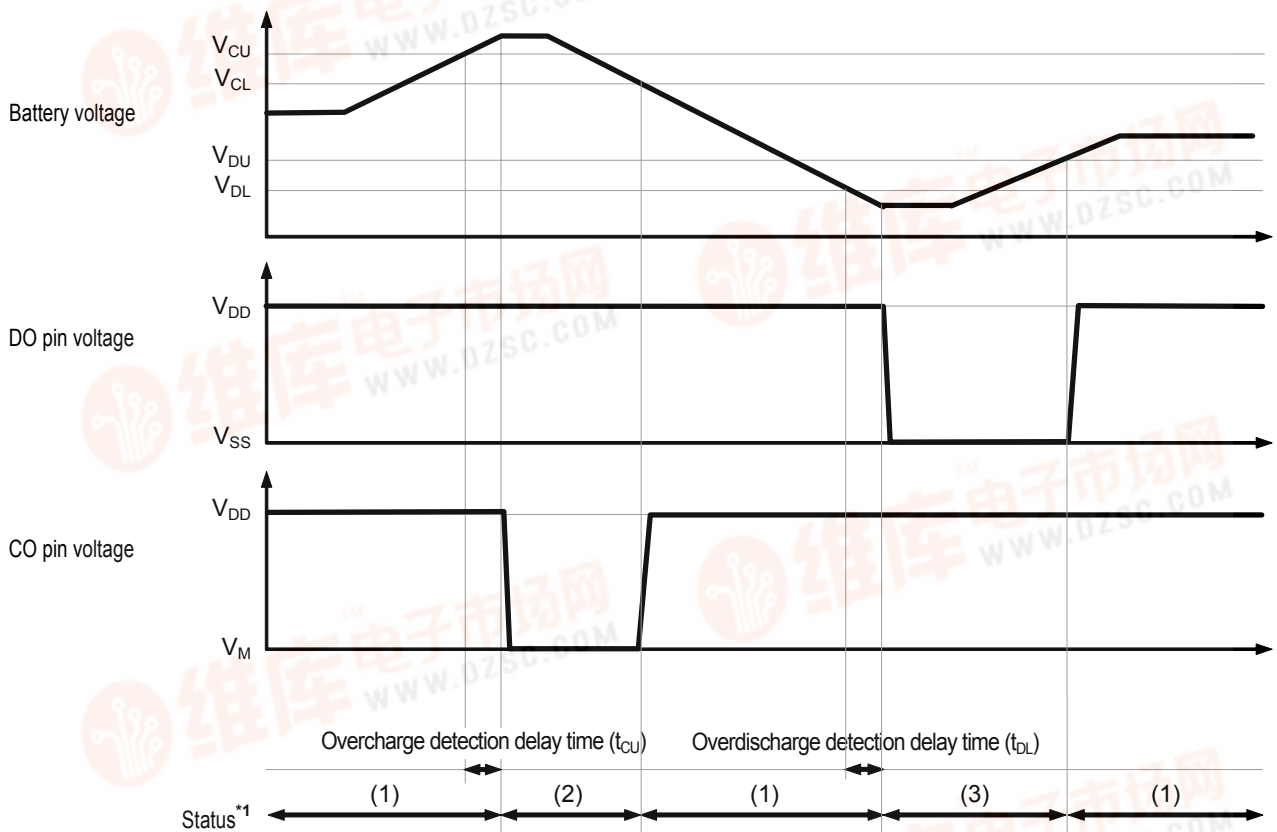

- *1. (1) : Normal status
- (2) : Overcharge status
- (3) : Overdischarge status

Figure 9

■ Battery Protection IC Connection Example

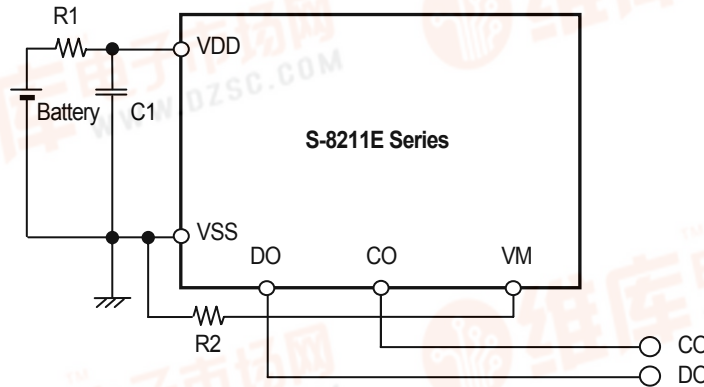

Figure 10

Table 13 Constants for External Components

Symbol	Part	Purpose	Typ.	Min.	Max.	Remark
R1	Resistor	ESD protection, For power fluctuation	220 Ω	100 Ω	330 Ω	Resistance should be as small as possible to avoid lowering the overcharge detection accuracy due to current consumption. ^{*1}
C1	Capacitor	For power fluctuation	0.1 μF	0.022 μF	1.0 μF	Connect a capacitor of 0.022 μF or higher between VDD pin and VSS pin. ^{*2}
R2 ^{*3}	Resistor	ESD protection	1 kΩ	300 Ω	4 kΩ	-

*1. Insert a resistor of 100 Ω or higher as R1 for ESD protection.

*2. If a capacitor of less than 0.022 μF is connected to C1, DO pin may oscillate. Be sure to connect a capacitor of 0.022 μF or higher to C1.

*3. Be sure to using R2, connect the VM pin with the VSS pin.

Caution 1. The above constants may be changed without notice.

2. It has not been confirmed whether the operation is normal or not in circuits other than the above example of connection. In addition, the example of connection shown above and the constant do not guarantee proper operation. Perform thorough evaluation using the actual application to set the constant.

■ Application Circuit Examples

1. Protection circuits series multi-cells

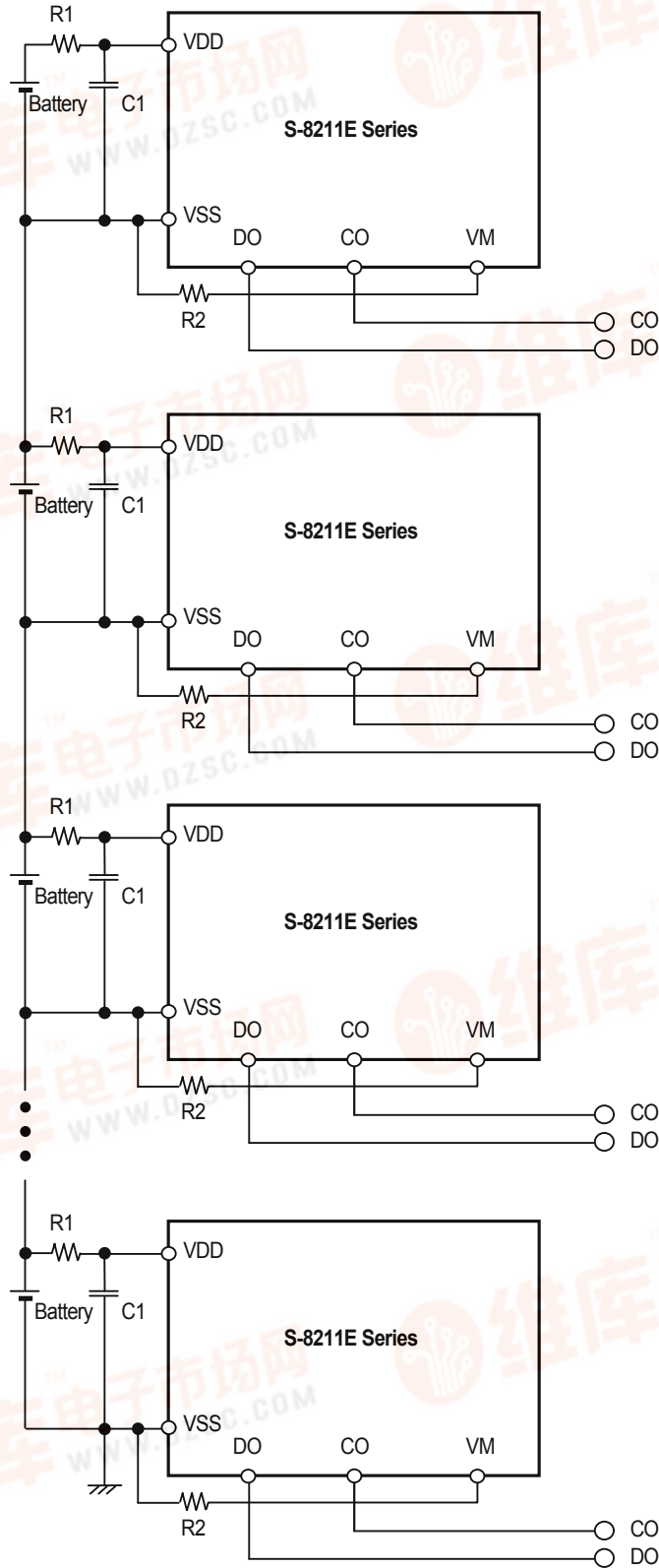

Figure 11

2. Charge cell-balance detection circuit

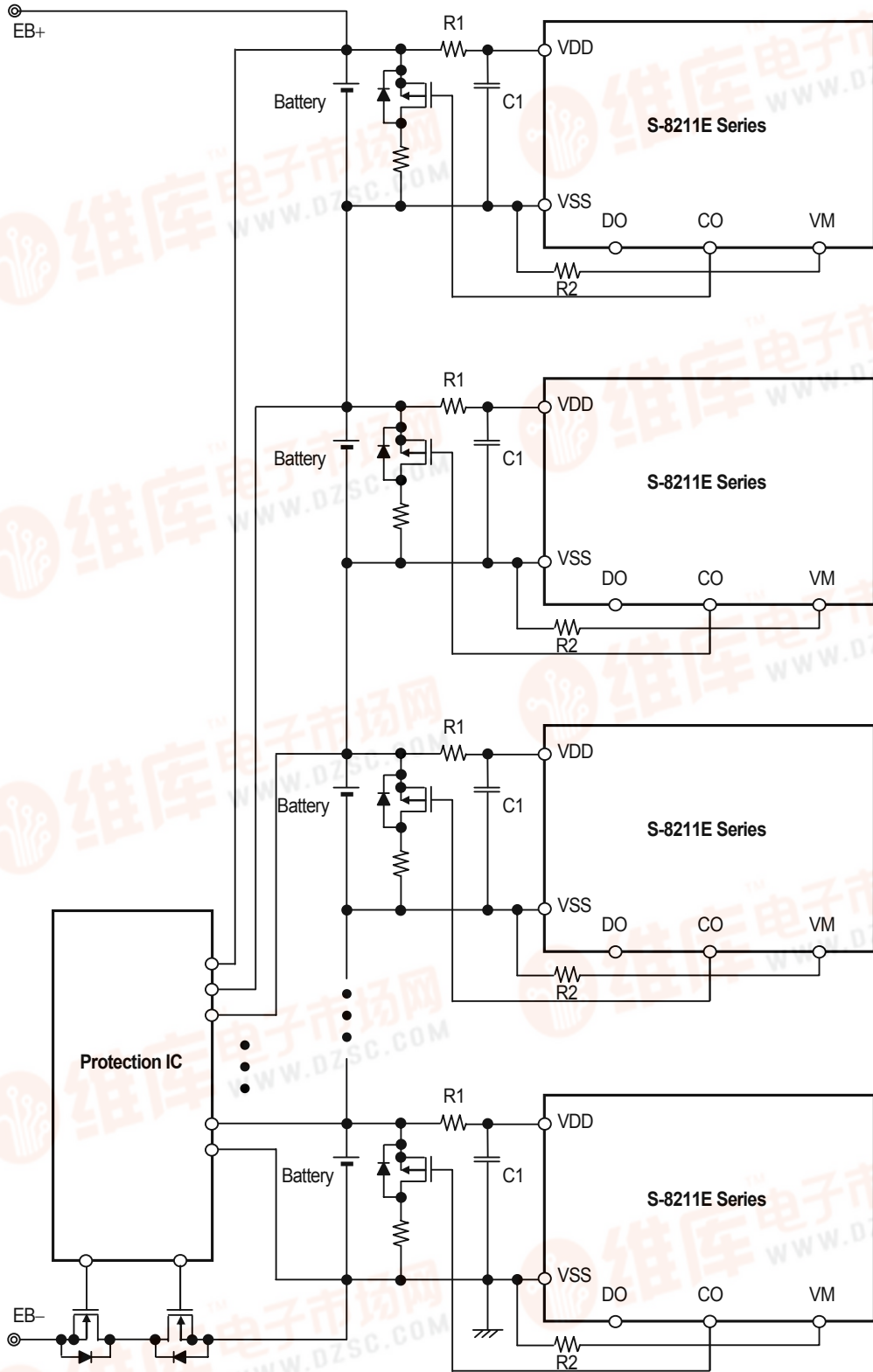

Figure 12



■ Precautions

- The application conditions for the input voltage, output voltage, and load current should not exceed the package power dissipation.
- Be sure to using R2, connect the VM pin with the VSS pin.
- Do not apply an electrostatic discharge to this IC that exceeds the performance ratings of the built-in electrostatic protection circuit.
- SII claims no responsibility for any and all disputes arising out of or in connection with any infringement by products including this IC of patents owned by a third party.

■ Characteristics (Typical Data)

1. Current Consumption

(1) I_{OPE} vs. T_a

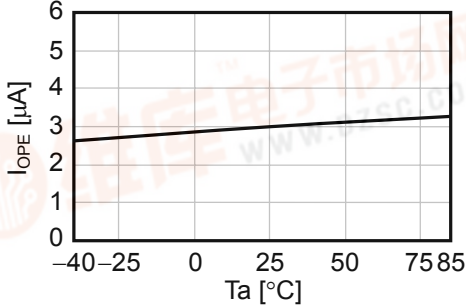

(2) I_{OPED} vs. T_a

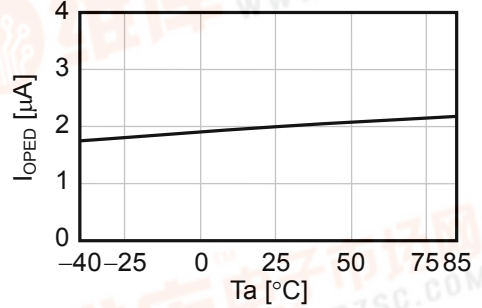

(3) I_{OPE} vs. V_{DD}

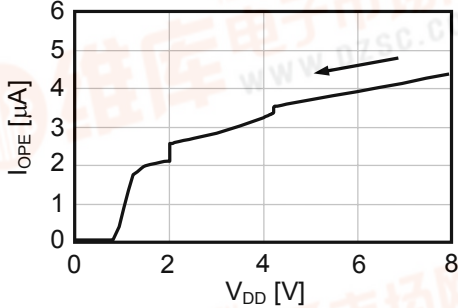

2. Overcharge Detection / Release Voltage, Overdischarge Detection / Release Voltage, Overcurrent Detection Voltage, and Delay Time

(1) V_{CU} vs. T_a

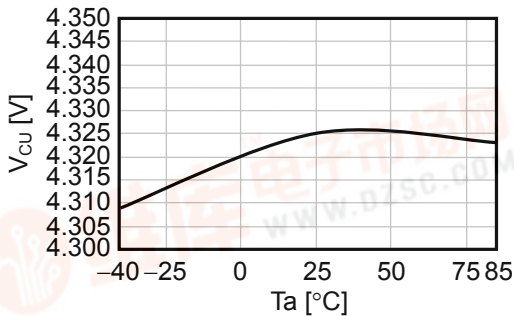

(2) V_{CL} vs. T_a

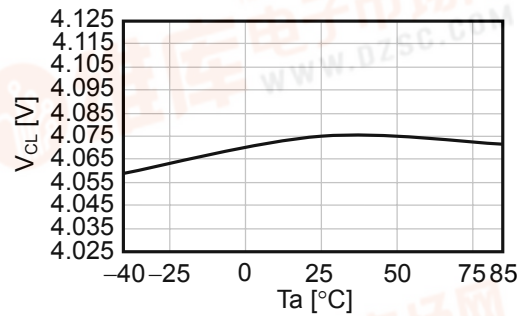

(3) V_{DU} vs. T_a

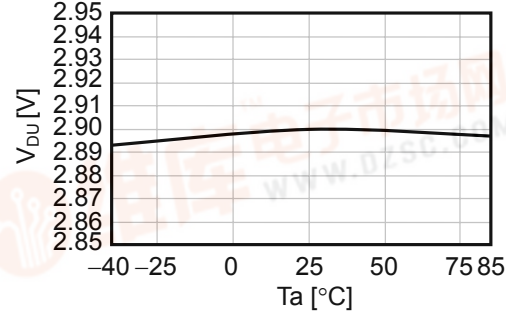

(4) V_{DL} vs. T_a

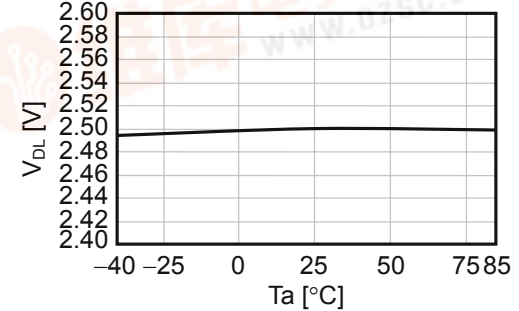

(5) t_{CU} vs. T_a

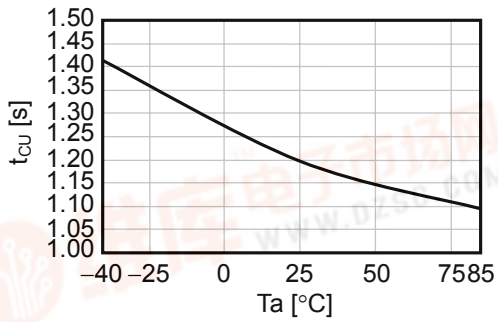

(6) t_{DL} vs. T_a

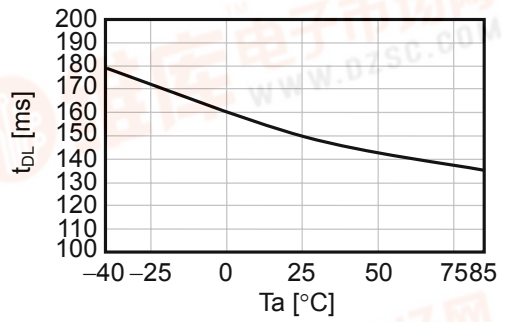

3. CO pin / DO pin

(1) I_{COH} vs. V_{CO}

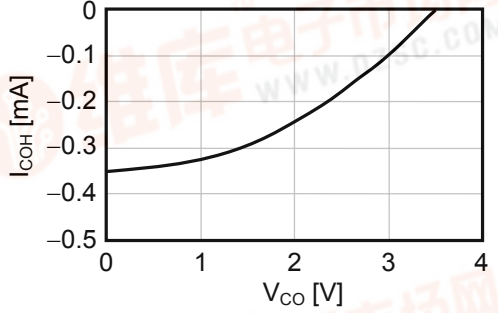

(2) I_{COL} vs. V_{CO}

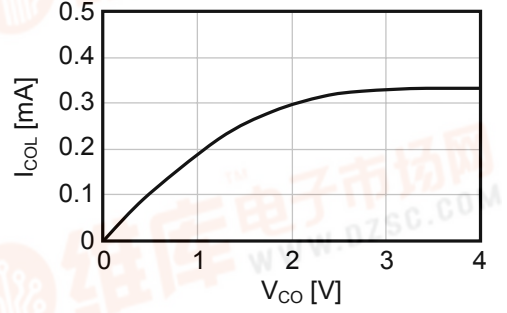

(3) I_{DOH} vs. V_{DO}

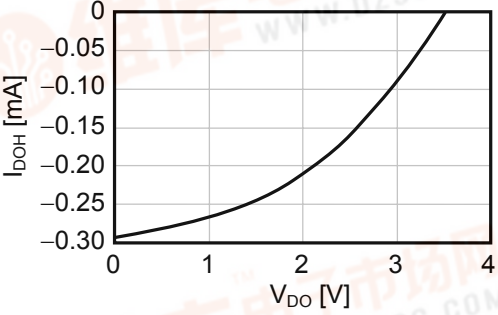

(4) I_{DOL} vs. V_{DO}

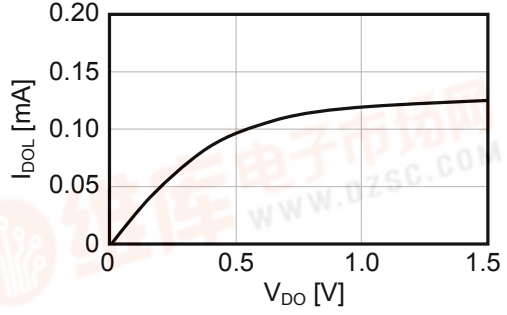

■ Marking Specifications

(1) SOT-23-5

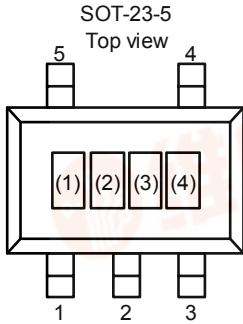

(1) to (3): Product Code (refer to **Product Name vs. Product Code**)
 (4) : Lot number

Product Name vs. Product Code

Product Name	Product Code		
	(1)	(2)	(3)
S-8211EAC-M5T1U	R	3	C

- Remark 1.** Please contact our sales office for the products other than those specified above.
2. Please select products of environmental code = U for Sn 100%, halogen-free products.

(2) SNT-6A

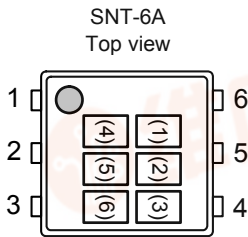

(1) to (3): Product Code (refer to **Product Name vs. Product Code**)
 (4) to (6): Lot number

Product Name vs. Product Code

Product Name	Product Code		
	(1)	(2)	(3)
S-8211EAA-I6T1x	R	3	A
S-8211EAB-I6T1x	R	3	B
S-8211EAD-I6T1x	R	3	D
S-8211EAE-I6T1x	R	3	E

- Remark 1.** Please contact our sales office for the products other than those specified above.
2. x: G or U
3. Please select products of environmental code = U for Sn 100%, halogen-free products.

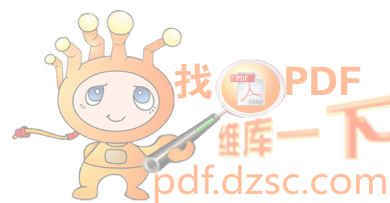

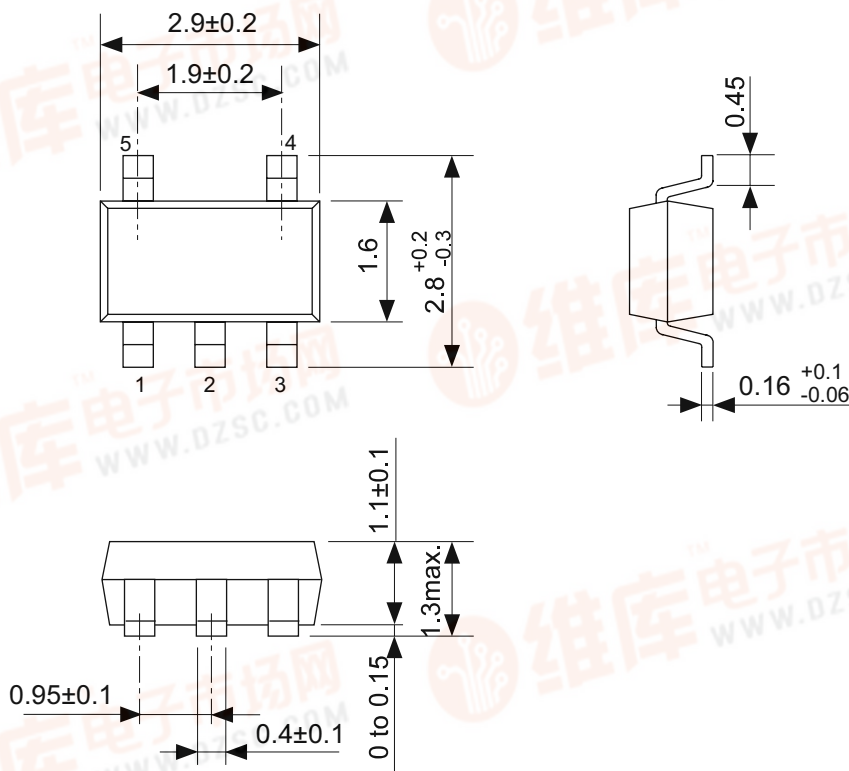

No. MP005-A-P-SD-1.2

TITLE	SOT235-A-PKG Dimensions
No.	MP005-A-P-SD-1.2
SCALE	
UNIT	mm
Seiko Instruments Inc.	

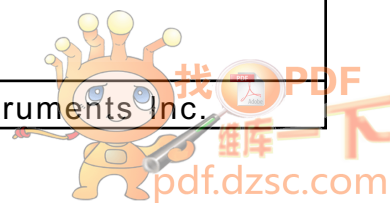

查询S-8211E供应商

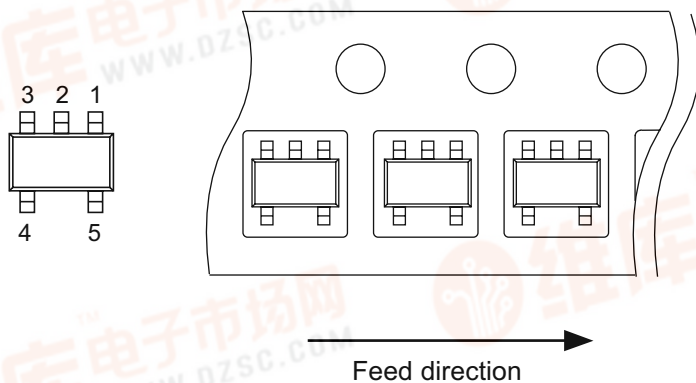
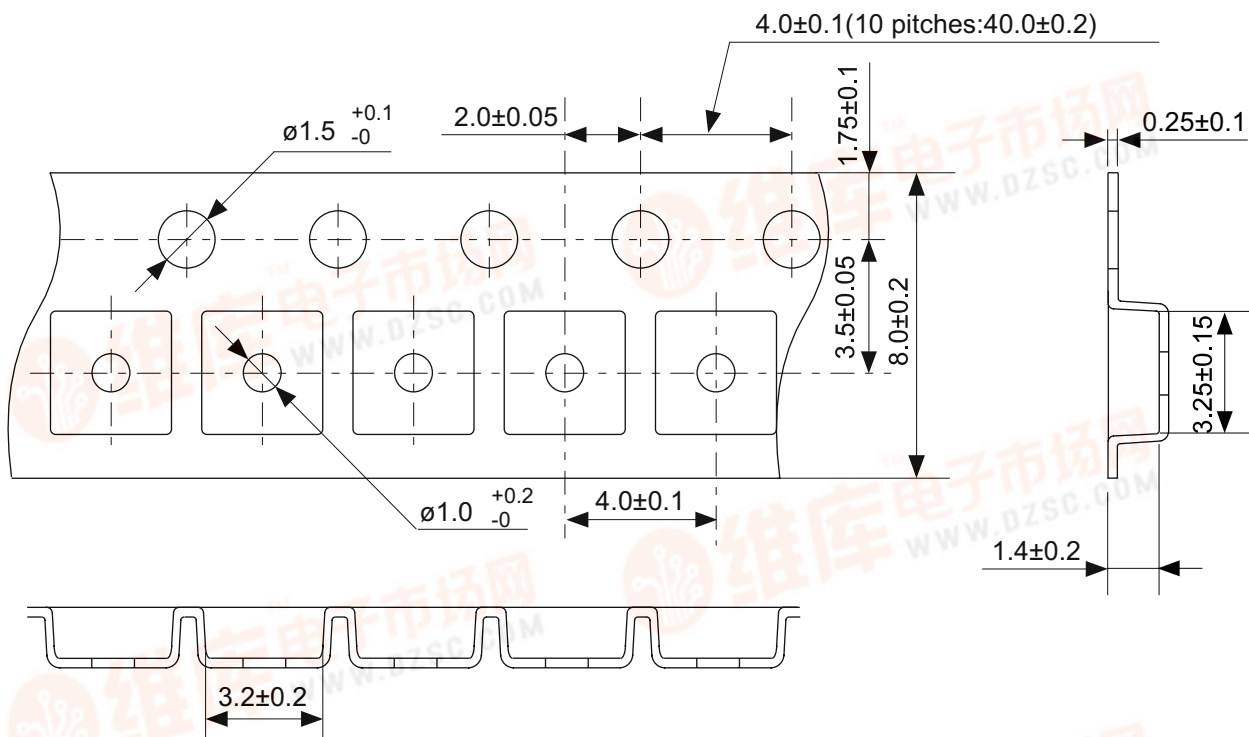

No. MP005-A-C-SD-2.1

TITLE	SOT235-A-Carrier Tape
No.	MP005-A-C-SD-2.1
SCALE	
UNIT	mm
Seiko Instruments Inc.	

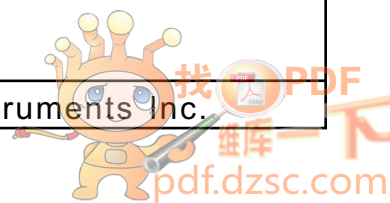

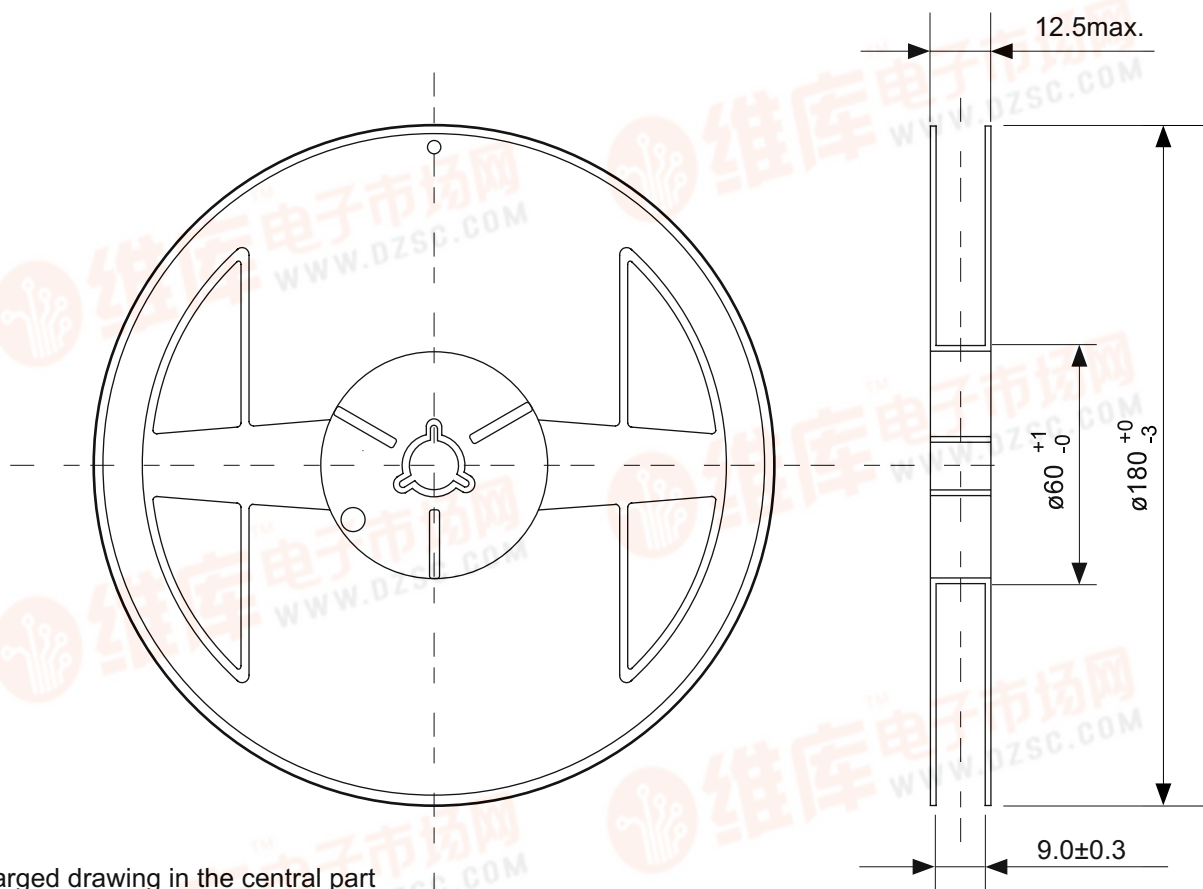

Enlarged drawing in the central part

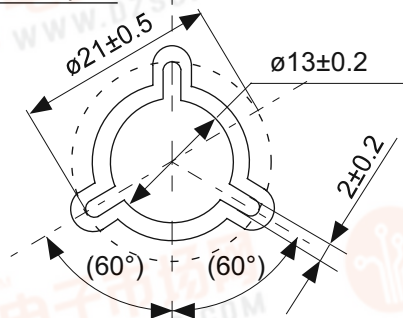

No. MP005-A-R-SD-1.1

TITLE	SOT235-A-Reel		
No.	MP005-A-R-SD-1.1		
SCALE		QTY.	3,000
UNIT	mm		

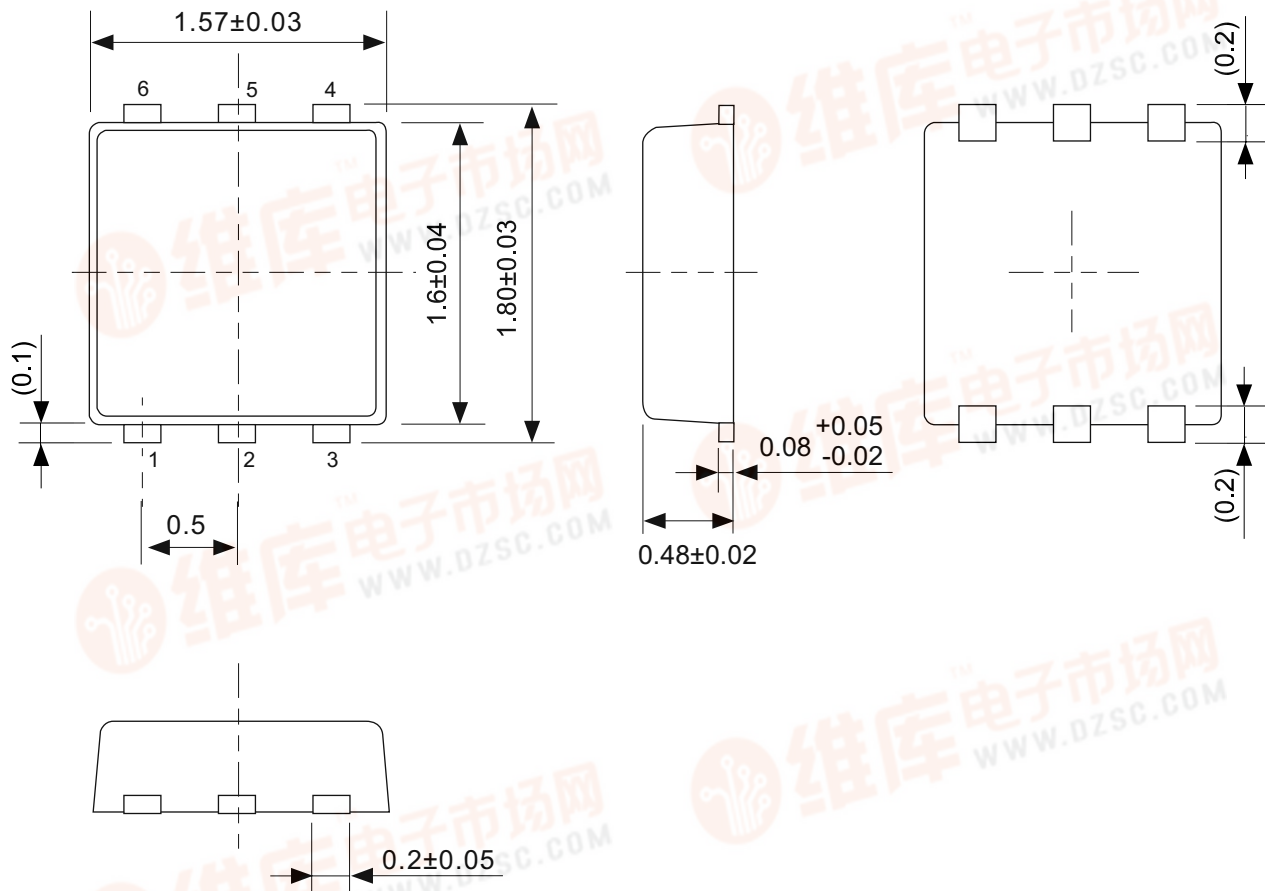

No. PG006-A-P-SD-2.0

TITLE	SNT-6A-A-PKG Dimensions
No.	PG006-A-P-SD-2.0
SCALE	
UNIT	mm
Seiko Instruments Inc.	



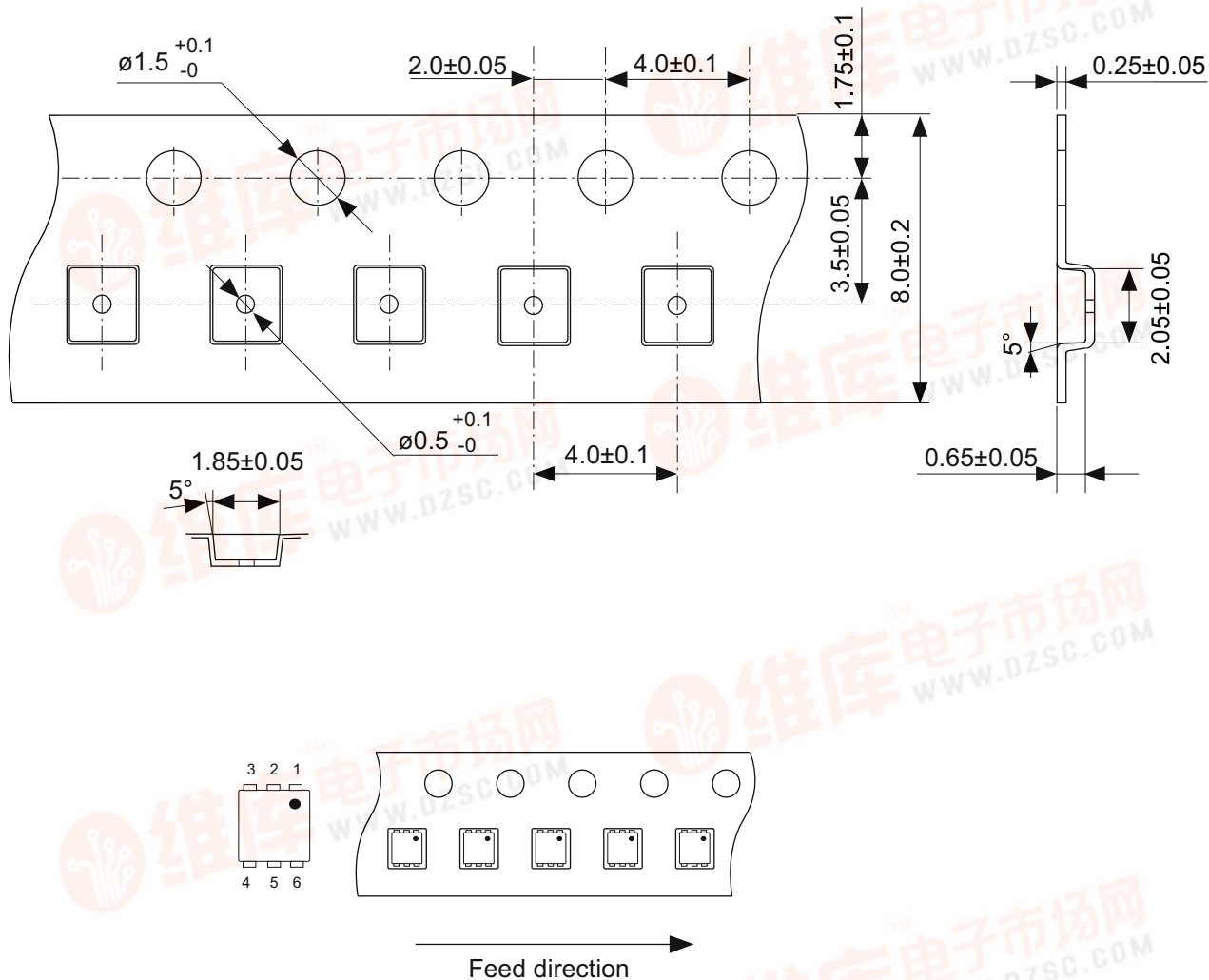

No. PG006-A-C-SD-1.0

TITLE	SNT-6A-A-Carrier Tape
No.	PG006-A-C-SD-1.0
SCALE	
UNIT	mm
Seiko Instruments Inc.	

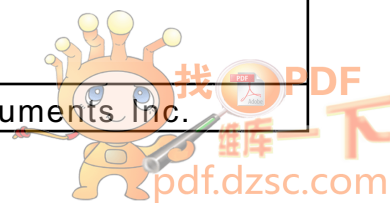

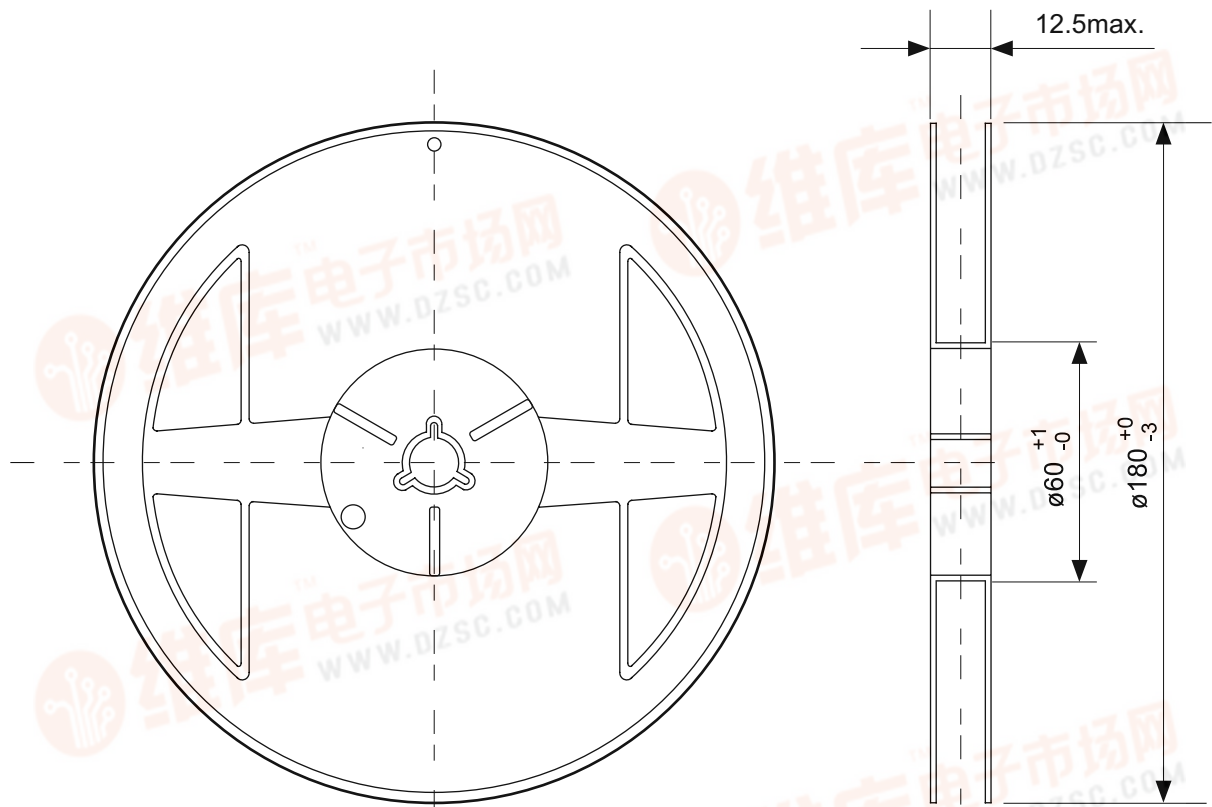

Enlarged drawing in the central part

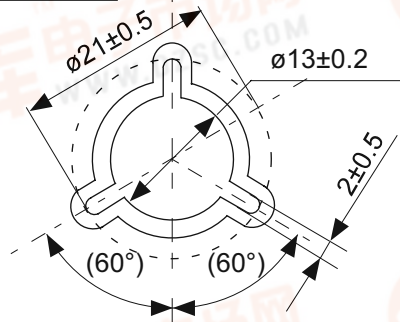

No. PG006-A-R-SD-1.0

TITLE	SNT-6A-A-Reel		
No.	PG006-A-R-SD-1.0		
SCALE		QTY.	5,000
UNIT	mm		
Seiko Instruments Inc.			

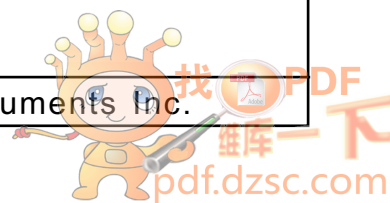

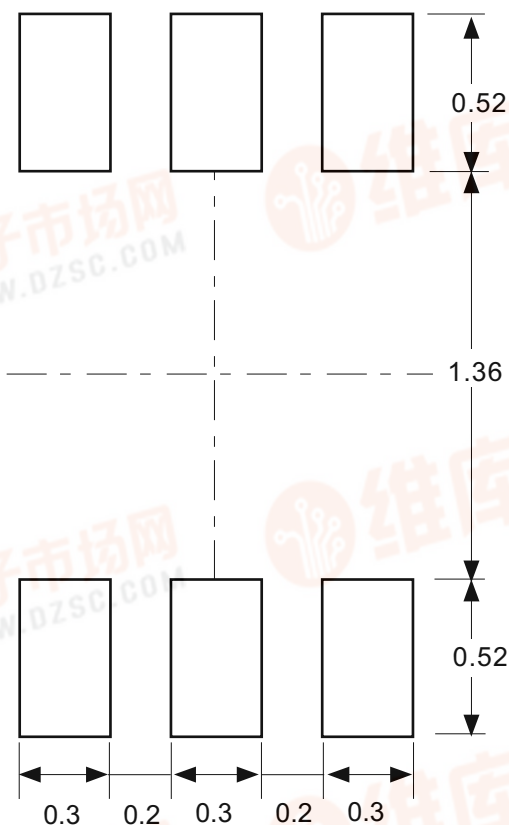

Caution Making the wire pattern under the package is possible. However, note that the package may be upraised due to the thickness made by the silk screen printing and of a solder resist on the pattern because this package does not have the standoff.

注意 パッケージ下への配線パターン形成は可能ですが、本パッケージはスタンドオフが無いので、パターン上のレジスト厚み、シルク印刷の厚みによってパッケージが持ち上がる場合がありますのでご配慮ください。

No. PG006-A-L-SD-3.0

TITLE	SNT-6A-A-Land Recommendation
No.	PG006-A-L-SD-3.0
SCALE	
UNIT	mm
Seiko Instruments, Inc.	

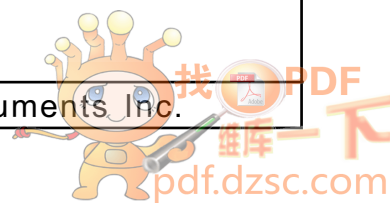



Seiko Instruments Inc.
www.sii-ic.com

- The information described herein is subject to change without notice.
- Seiko Instruments Inc. is not responsible for any problems caused by circuits or diagrams described herein whose related industrial properties, patents, or other rights belong to third parties. The application circuit examples explain typical applications of the products, and do not guarantee the success of any specific mass-production design.
- When the products described herein are regulated products subject to the Wassenaar Arrangement or other agreements, they may not be exported without authorization from the appropriate governmental authority.
- Use of the information described herein for other purposes and/or reproduction or copying without the express permission of Seiko Instruments Inc. is strictly prohibited.
- The products described herein cannot be used as part of any device or equipment affecting the human body, such as exercise equipment, medical equipment, security systems, gas equipment, or any apparatus installed in airplanes and other vehicles, without prior written permission of Seiko Instruments Inc.
- Although Seiko Instruments Inc. exerts the greatest possible effort to ensure high quality and reliability, the failure or malfunction of semiconductor products may occur. The user of these products should therefore give thorough consideration to safety design, including redundancy, fire-prevention measures, and malfunction prevention, to prevent any accidents, fires, or community damage that may ensue.

