

150mA Small Dual LDO Regulator with ON/OFF Switch

■ GENERAL DESCRIPTION

The XC6420 series is a small dual CMOS LDO regulator with 2-channel 150mA outputs. The series features high speed, high accuracy, high ripple rejection and low dropout voltage. The series is capable of high density board installation by the small package of two low on-resistance regulators. Each output voltage is internally set in a range from 1.2V to 3.6V in increments of 0.05V with $\pm 2\%$ accuracy.

The EN function controls the two regulators on/off independently. In the stand-by mode, the electric charge at the output capacitor C_L is discharged via the internal switch and as a result the VOUT pin quickly returns to the VSS level.

The series is also compatible with low ESR ceramic capacitors. The high level of output stability is maintained even during frequent load fluctuations, due to the excellent transient response performance. The two regulators are completely isolated so that a cross talk during load fluctuations is minimized.

APPLICATIONS

- Mobile phones
- Portable game consoles
- Portable multimedia player
- Digital still cameras, Camcorders

■ FEATURES

| | |
|-----------------------------|-----------------------------------------------------------|
| Maximum Output Current | : 150mA |
| Operating Voltage Range | : 1.6V~5.5V |
| Output Voltage | : 1.2V~3.6V ($\pm 2\%$) 0.05V increments |
| Dropout Voltage | : 190mV @ $I_{OUT}=150mA$ ($V_{OUT}=3.3V$) |
| Low Power Consumption | : 55 μA / ch (TYP.) |
| Stand-by Current | : 0.1 μA |
| Ripple Rejection | : 75dB@1kHz |
| EN Function | : Active High |
| | C_L High Speed Auto Discharge |
| Protection Circuit | : Current Limit 250mA (TYP.) Short Circuit 50mA (TYP.) |
| Output Capacitor | : 1.0 μF Ceramic Capacitor |
| Operating Temperature Range | : $-40^{\circ}C \sim +85^{\circ}C$ |
| Packages | : USPN-6 (1.3 x 1.3 x h0.4mm) SOT-26 |
| Environmentally Friendly | : EU RoHS Compliant, Pb Free |

TYPICAL APPLICATION CIRCUITS

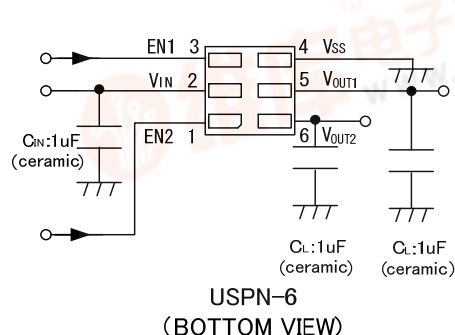
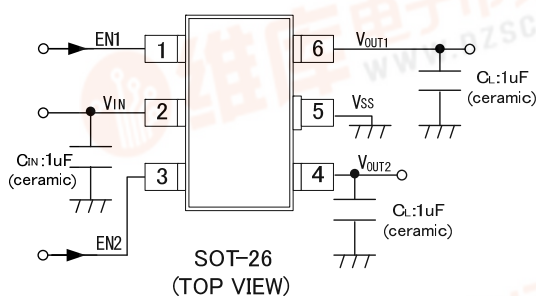

TYPICAL PERFORMANCE CHARACTERISTICS

Ripple Rejection

XC6420 ($V_{OUT}=1.8V$)
 $V_{IN}=3.0V+0.5V_{r-RMS}$, $T_a=25^{\circ}C$
 $C_{IN}=0.1 \mu F$ (ceramic), $C_L=1.0 \mu F$ (ceramic)

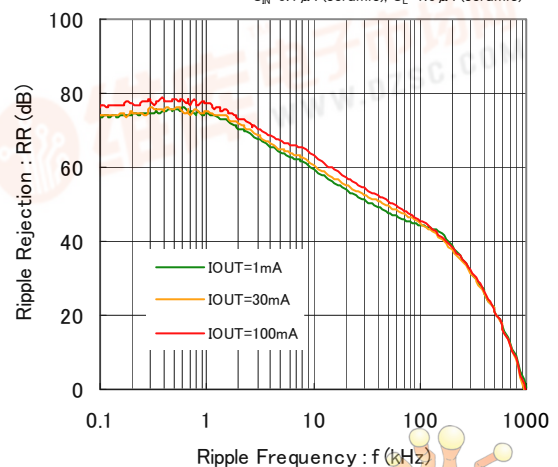

XC6420 Series

[查询XC6420供应商](#)

PIN CONFIGURATION

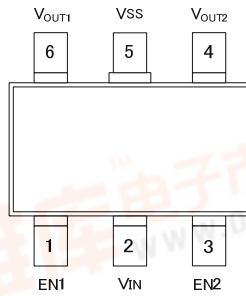

SOT-26
(TOP VIEW)

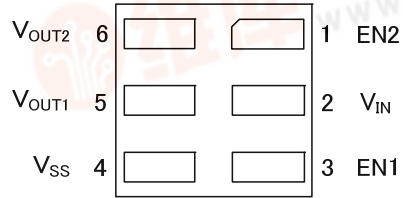

USPN-6
(BOTTOM VIEW)

PIN ASSIGNMENT

| PIN NUMBER | | PIN NAME | FUNCTIONS |
|------------|--------|------------|------------------|
| SOT-26 | USPN-6 | | |
| 1 | 3 | EN1 | ON/OFF Control 1 |
| 2 | 2 | V_{IN} | Power Input |
| 3 | 1 | EN2 | ON/OFF Control 2 |
| 4 | 6 | V_{OUT2} | Output 2 |
| 5 | 4 | V_{SS} | Ground |
| 6 | 5 | V_{OUT1} | Output 1 |

[查询XC6420供应商](#)

PRODUCT CLASSIFICATION

Ordering Information

XC6420①②③④⑤⑥-⑦^(*)

| DESIGNATOR | ITEM | SYMBOL | DESCRIPTION |
|---------------------|-----------------------|--------|---------------------------------------------------------------------------------------------------------------------------------------------------------|
| ① | Basic Function | A | EN1: Active High, EN2: Active High V _{OUT1} : with C _L Auto Discharge, V _{OUT2} : with C _L Auto Discharge |
| ② | Enable Pin | B | EN1: With Pull-down, With EN2: Pull-down |
| ③④ | Output Voltage | 01 ~ | See the chart below |
| ⑤⑥-⑦ ^(*) | Packages (Order Unit) | 7R-G | USPN-6 (5,000/Reel) |
| | | MR-G | SOT-26 (3,000/Reel) |

^(*) The "-G" suffix indicates that the products are Halogen and Antimony free as well as being fully RoHS compliant.

DESIGNATOR

| | V _{OUT1} (V) | V _{OUT2} (V) |
|----|-----------------------|-----------------------|
| 01 | 1.20 | 1.20 |
| 02 | 1.20 | 1.50 |
| 03 | 1.20 | 2.50 |
| 04 | 1.20 | 2.85 |
| 05 | 1.20 | 3.00 |
| 06 | 1.20 | 3.30 |
| 07 | 1.50 | 1.50 |
| 08 | 1.50 | 1.80 |
| 09 | 1.50 | 2.50 |
| 10 | 1.50 | 2.85 |
| 11 | 1.50 | 3.00 |
| 12 | 1.50 | 3.30 |
| 13 | 1.80 | 1.80 |
| 14 | 1.80 | 2.50 |
| 15 | 2.85 | 2.85 |
| 16 | 1.80 | 2.85 |
| 17 | 1.80 | 3.00 |
| 18 | 3.00 | 1.80 |
| 19 | 1.80 | 3.30 |
| 20 | 2.50 | 2.50 |
| 21 | 2.50 | 2.80 |
| 22 | 2.50 | 2.85 |
| 23 | 3.30 | 1.50 |
| 24 | 2.50 | 3.00 |
| 25 | 2.50 | 3.30 |

| | V _{OUT1} (V) | V _{OUT2} (V) |
|----|-----------------------|-----------------------|
| 26 | 2.85 | 3.00 |
| 27 | 2.85 | 3.30 |
| 28 | 3.00 | 3.00 |
| 29 | 1.20 | 1.80 |
| 30 | 1.30 | 2.80 |
| 31 | 1.50 | 2.80 |
| 32 | 1.80 | 2.80 |
| 33 | 2.80 | 2.80 |
| 34 | 2.80 | 3.00 |
| 35 | 2.80 | 3.30 |
| 36 | 1.20 | 3.60 |
| 37 | 3.60 | 1.20 |
| 38 | 1.20 | 2.80 |
| 39 | 3.30 | 2.00 |
| 40 | 3.00 | 3.30 |
| 41 | 3.30 | 3.30 |
| 42 | 1.30 | 1.50 |
| 43 | 2.60 | 2.80 |
| 44 | 3.10 | 3.30 |
| 45 | 1.50 | 2.60 |
| 46 | 2.60 | 3.30 |
| | | |
| | | |
| | | |

*For other output voltage combinations, please contact your local Torex sales office or representative.

BLOCK DIAGRAMS

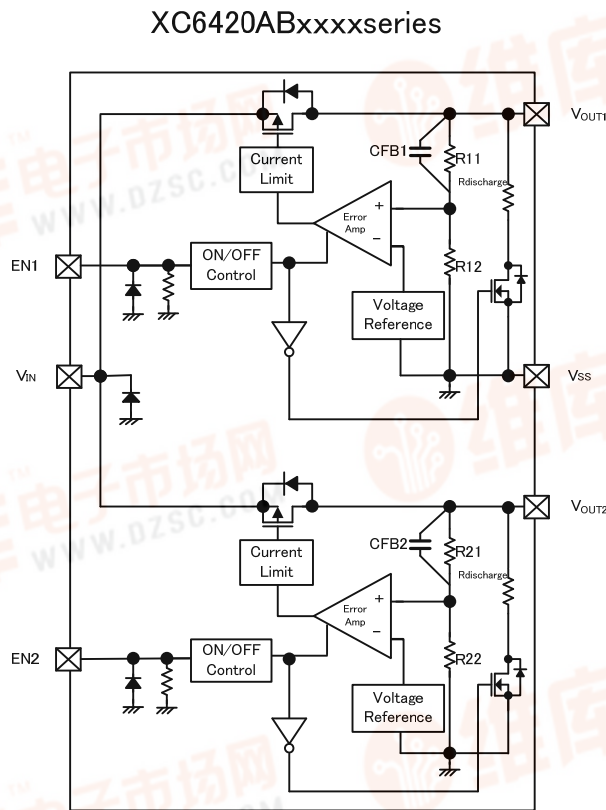

* Diodes inside the circuits are ESD protection diodes and parasitic diodes.

ABSOLUTE MAXIMUM RATINGS

| PARAMETER | | SYMBOL | RATINGS | UNITS |
|------------------------------------|--------|-----------------------|-----------------------------------|-------|
| Input Voltage | | V_{IN} | $V_{SS}-0.3 \sim +7.0$ | V |
| Output Current | | $I_{OUT1}+I_{OUT2}$ | 600 ^(*) | mA |
| Output Voltage 1 / Output Voltage2 | | V_{OUT1} / V_{OUT2} | $V_{SS}-0.3 \sim V_{IN}+0.3$ | V |
| EN1/EN2 Input Voltage | | V_{EN1} / V_{EN2} | $V_{SS}-0.3 \sim +7.0$ | V |
| Power Dissipation | SOT-26 | Pd | 250 | mW |
| | | | 600 (PCB mounted) ^(**) | |
| | USPN-6 | | 100 | |
| | | | 600 (PCB mounted) ^(**) | |
| Operating Temperature Range | | T _{opr} | -40~+85 | °C |
| Storage Temperature Range | | T _{stg} | -55~+125 | °C |

^(*) Please use within the range of $P_d > \{ (V_{IN}-V_{OUT1}) \times I_{OUT1} + (V_{IN}-V_{OUT2}) \times I_{OUT2} \}$

^(**) This is a reference data taken by using the test board. Please refer to 21~22 for detail information of test condition.

[查询XC6420供应商](#)

ELECTRICAL CHARACTERISTICS

●XC6420 series

Regulator 1, Regulator 2 ^(*8)

Ta=25°C

| PARAMETER | SYMBOL | CONDITIONS | MIN. | TYP. | MAX. | UNITS | CIRCUITS |
|--------------------------------------------------------|-------------------------------------------------------------|-------------------------------------------------------------------------------------------------------------------------------------------------------------------------------------------------------------------------------------------------------------------------------------|--------------------------------------------|-------------------------------------|--------------------------------------------|----------|----------|
| Output Voltage | V _{OUT(E)} ^(*2) | V _{EN} = V _{IN} , I _{OUT} = 10mA | V _{OUT(T)} × 0.98 ^(*3) | V _{OUT(T)} ^(*4) | V _{OUT(T)} × 1.02 ^(*3) | V | ① |
| Maximum Output Current | I _{OUTMAX} | V _{EN} = V _{IN} | 150 | - | - | mA | ① |
| Load Regulation | ΔV _{OUT} | V _{EN} = V _{IN} 0.1mA ≤ I _{OUT} ≤ 150mA | - | 25 | 45 | mV | ① |
| Dropout Voltage ^(*5) | V _{dif} | I _{OUT} = 150mA, V _{EN} = V _{IN} | See "OUTPUT VOLTAGE CHART" | | | mV | ① |
| Supply Current | I _{DD} | V _{EN} = V _{IN} I _{OUT} = 0mA | - | 55 | 105 | μA | ② |
| Stand-by Current | I _{STB} | V _{EN} = V _{SS} | - | 0.01 | 0.1 | μA | ② |
| Line Regulation | ΔV _{OUT} / (ΔV _{IN} · V _{OUT}) | 2.5V ≤ V _{IN} ≤ 5.0V (V _{OUT(T)} ≤ 2.0V) V _{EN} = V _{IN} , I _{OUT} = 30mA V _{OUT(T)} + 0.5V ≤ V _{IN} ≤ 5.5V (V _{OUT(T)} ≥ 2.05V) V _{EN} = V _{IN} , I _{OUT} = 30mA | - | 0.02 | 0.1 | %/V | ① |
| Input Voltage | V _{IN} | - | 1.6 | - | 5.5 | V | ① |
| Output Voltage Temperature Characteristics (R&D Value) | ΔV _{OUT} / (ΔT _{opr} · V _{OUT}) | V _{EN} = V _{IN} , I _{OUT} = 10mA -40°C ≤ Ta ≤ 85°C | - | ±100 | - | ppm / °C | ① |
| Ripple Rejection Rate | PSRR | V _{EN} = V _{IN} V _{IN} {V _{OUT(T)} +1.0}+0.5Vp-pAC I _{OUT} = 30mA, f=1kHz | - | 75 | - | dB | ③ |
| Limit Current | I _{LIM} | V _{EN} = V _{IN} | 150 | 250 | - | mA | ① |
| Short Current | I _{SHORT} | V _{EN} = V _{IN} V _{OUT} = V _{SS} | - | 50 | - | mA | ① |
| EN"H"Level Voltage | V _{ENH} | - | 1.0 | - | 5.5 | V | ① |
| EN"L"Level Voltage | V _{ENL} | - | - | - | 0.3 | V | ① |
| EN"H"Level Current | I _{ENH} | V _{EN} = V _{IN} = 5.5V | 2.5 | 6.0 | 9.1 | μA | ① |
| EN"L"Level Current | I _{ENL} | V _{EN} = V _{SS} | -0.1 | - | 0.1 | μA | ① |
| CL Discharge Resistor | R _{DCHG} | V _{IN} = 5.5V, V _{EN} = V _{SS} V _{OUT} = 2.0V | - | 300 | - | Ω | ① |

NOTE:

(*1) Unless otherwise stated, V_{IN} = V_{OUT(T)} + 1.0V.

(*2) V_{OUT(E)} = Effective output voltage (see the voltage chart)

(ie. The output voltage when "V_{OUT(T)}+1.0V" is provided at the V_{IN} pin while maintaining a certain I_{OUT} value.

(*3) Characteristics of the actual V_{OUT(E)} by setting output voltage is shown in the voltage chart.

(*4) V_{OUT(T)}: Nominal output voltage

(*5) V_{dif} = {V_{IN} ^(*7) - V_{OUT1} ^(*6)}

(*6) V_{OUT1}: A voltage equal to 98% of the output voltage whenever an amply stabilized I_{OUT}{V_{OUT(T)}+1.0V} is input.

(*7) V_{IN1}: The input voltage when V_{OUT1} appears as input voltage is gradually decreased.

(*8) Each channel is measured when the other channel is turned off (V_{EN} = V_{SS}).

OUTPUT VOLTAGE CHART

| NOMINAL OUTPUT VOLTAGE (V) | OUTPUT VOLTAGE (V) | | DROPOUT VOLTAGE (mV) | |
|-------------------------------------|--------------------------|-------|----------------------------|------|
| | $V_{OUT(E)}$ | | V_{dif} | |
| | MIN. | MAX. | TYP. | MAX. |
| $V_{OUT(T)}$ | | | | |
| 1.200 | 1.176 | 1.224 | 560 | 710 |
| 1.250 | 1.225 | 1.275 | | |
| 1.300 | 1.274 | 1.326 | 530 | 600 |
| 1.350 | 1.323 | 1.377 | | |
| 1.400 | 1.372 | 1.428 | 460 | 520 |
| 1.450 | 1.421 | 1.479 | | |
| 1.500 | 1.470 | 1.530 | | |
| 1.550 | 1.519 | 1.581 | | |
| 1.600 | 1.568 | 1.632 | 380 | 470 |
| 1.650 | 1.617 | 1.683 | | |
| 1.700 | 1.666 | 1.734 | | |
| 1.750 | 1.715 | 1.785 | | |
| 1.800 | 1.764 | 1.836 | 300 | 450 |
| 1.850 | 1.813 | 1.887 | | |
| 1.900 | 1.862 | 1.938 | | |
| 1.950 | 1.911 | 1.989 | | |
| 2.000 | 1.960 | 2.040 | 280 | 390 |
| 2.050 | 2.009 | 2.091 | | |
| 2.100 | 2.058 | 2.142 | | |
| 2.150 | 2.107 | 2.193 | | |
| 2.200 | 2.156 | 2.244 | | |
| 2.250 | 2.205 | 2.295 | | |
| 2.300 | 2.254 | 2.346 | | |
| 2.350 | 2.303 | 2.397 | | |
| 2.400 | 2.352 | 2.448 | | |

| NOMINAL OUTPUT VOLTAGE (V) | OUTPUT VOLTAGE (V) | | DROPOUT VOLTAGE (mV) | |
|-------------------------------------|--------------------------|-------|----------------------------|------|
| | $V_{OUT(E)}$ | | V_{dif} | |
| | MIN. | MAX. | TYP. | MAX. |
| $V_{OUT(T)}$ | | | | |
| 2.450 | 2.401 | 2.499 | 280 | 390 |
| 2.500 | 2.450 | 2.550 | 200 | 340 |
| 2.550 | 2.499 | 2.601 | | |
| 2.600 | 2.548 | 2.652 | | |
| 2.650 | 2.597 | 2.703 | | |
| 2.700 | 2.646 | 2.754 | | |
| 2.750 | 2.695 | 2.805 | | |
| 2.800 | 2.744 | 2.856 | | |
| 2.850 | 2.793 | 2.907 | | |
| 2.900 | 2.842 | 2.958 | | |
| 2.950 | 2.891 | 3.009 | | |
| 3.000 | 2.940 | 3.060 | 190 | 270 |
| 3.050 | 2.989 | 3.111 | | |
| 3.100 | 3.038 | 3.162 | | |
| 3.150 | 3.087 | 3.213 | | |
| 3.200 | 3.136 | 3.264 | | |
| 3.250 | 3.185 | 3.315 | | |
| 3.300 | 3.234 | 3.366 | | |
| 3.350 | 3.283 | 3.417 | | |
| 3.400 | 3.332 | 3.468 | | |
| 3.450 | 3.381 | 3.519 | | |
| 3.500 | 3.430 | 3.570 | | |
| 3.550 | 3.479 | 3.621 | | |
| 3.600 | 3.528 | 3.672 | | |

[查询XC6420供应商](#)

OPERATIONAL EXPLANATION

The voltage divided by resistors Rx1 & Rx2 is compared with the internal reference voltage by the error amplifier. The P-channel MOSFET connected to the VOUT pin is then driven by the subsequent output signal. The output voltage at the VOUT pin is controlled & stabilized by a system of negative feedback. The current limit circuit and short protect circuit operate in relation to the level of output current. Further, the IC's internal circuitry can be shutdown via the EN pin's signal.

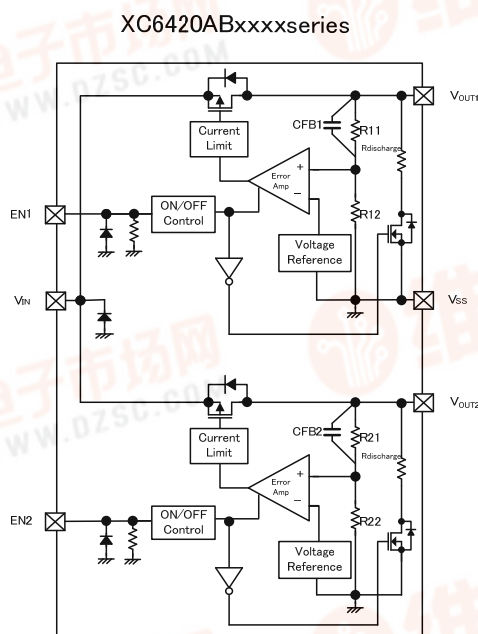

<Low ESR Capacitor>

The XC6420 needs an output capacitor (C_L) for phase compensation. In order to ensure the effectiveness of the phase compensation, we suggest that an output capacitor (C_L) is connected as close as possible to the output pin (VOUT) and the VSS pin. Please use an output capacitor with a capacitance value of at least $1.0 \mu\text{F}$. Also, please place $1.0 \mu\text{F}$ input capacitor C_L between VIN and VSS pins for stabilizing input supply voltage.

<Current Limiter, Short-Circuit Protection>

The XC6420 includes a combination of a fixed current limiter circuit & a foldback circuit, which aid the operations of the current limiter and circuit protection. When the load current reaches the current limit level, the fixed current limiter circuit operates and output voltage drops. As a result of this drop in output voltage, the foldback circuit operates, output voltage drops further and output current decreases. When the output pin is shorted, a current of about 50mA flows.

<EN Pin>

The IC's internal circuitry can be shutdown via the signal from the EN pin with the XC6420 series. In shutdown mode, the series enables the electric charge at the output capacitor C_L to be discharged via the internal switch between VOUT pin and VSS pin, and as a result the VOUT pin quickly returns to the V_{SS} level.

The EN pin is internally pulled down by a resistor. Please note that input current through a pull-down resistor exists.

< C_L Auto-Discharge Function>

XC6420 series can quickly discharge the electric charge at the output capacitor (C_L), when a low signal to the EN pin, which enables a whole IC circuit put into OFF state, is inputted via the N-channel transistor located between the VOUT pin and the VSS pin (cf. BLOCK DIAGRAM). The C_L discharge resistance is set to 300Ω when V_{IN} is 5.5V (TYP.) and V_{OUT} is 2.0V (TYP.). Moreover, discharge time of the output capacitor (C_L) is set by the C_L auto-discharge resistance and the output capacitor (C_L). By setting time constant of a C_L auto-discharge resistance value [R_{DCHG}] and an output capacitor value (C_L) as $t = C \times R$, the output voltage after discharge via the N channel transistor is calculated by the following formulas.

$$V = V_{OUT(E)} \times e^{-t/R} , \text{ or } t = R \ln (V_{OUT(E)} / V)$$

V : Output voltage after discharge, $V_{OUT(E)}$: Output voltage, t : Discharge time,

R : C_L auto-discharge resistance R_{DCHG} × Output capacitor (C_L) value C

NOTES ON USE

1. For temporary, transitional voltage drop or voltage rising phenomenon, the IC is liable to malfunction should the ratings be exceeded.
2. Torex places an importance on improving our products and its reliability. However, by any possibility, we would request user fail-safe design and post-aging treatment on system or equipment.
3. Where wiring impedance is high, operations may become unstable due to the noise and/or phase lag depending on output current. Please strengthen V_{IN} and V_{SS} wiring in particular.
4. Please wire the input capacitor (C_{IN}) and the output capacitor (C_L) as short and close to the IC as possible.

[查询XC6420供应商](#)

TEST CIRCUITS

Circuit

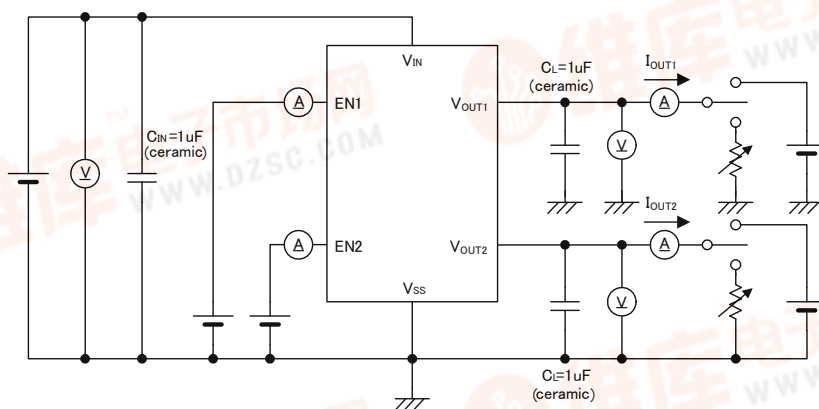

Circuit

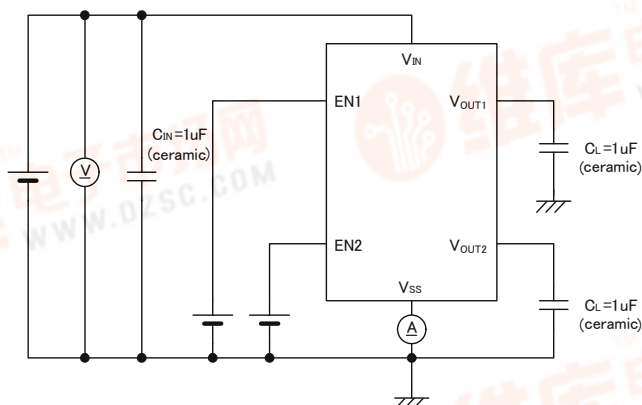

Circuit

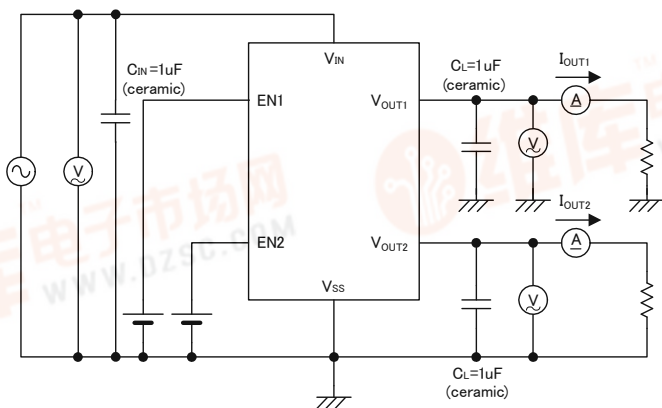

XC6420 Series

查询XC6420供应商

TYPICAL PERFORMANCE CHARACTERISTICS

* EN Voltage condition: Unless otherwise stated, $V_{EN}=V_{IN}$.

(1) Output Voltage vs. Output Current

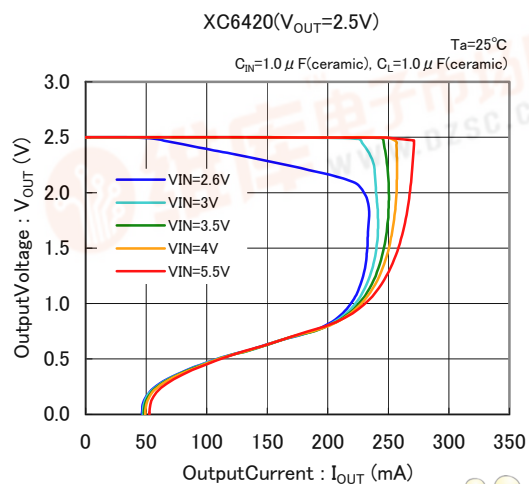
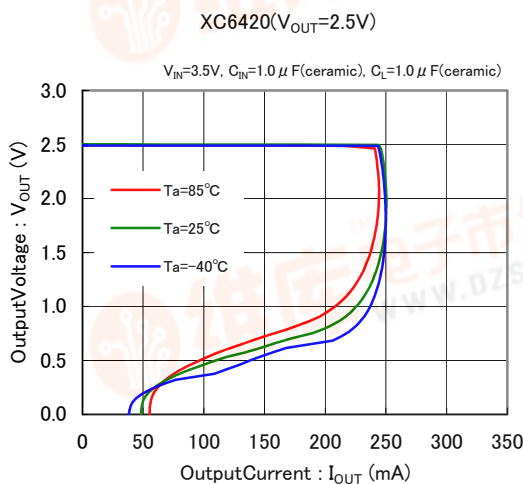
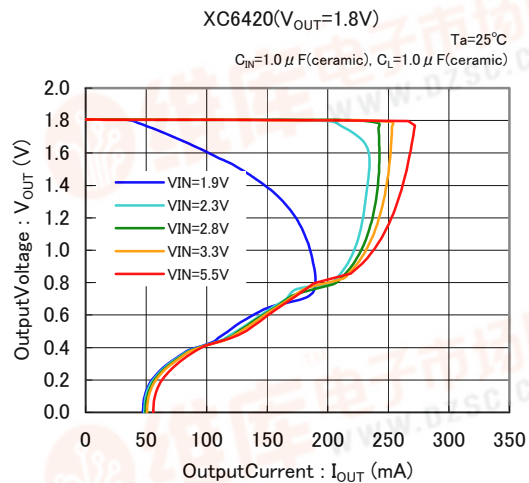
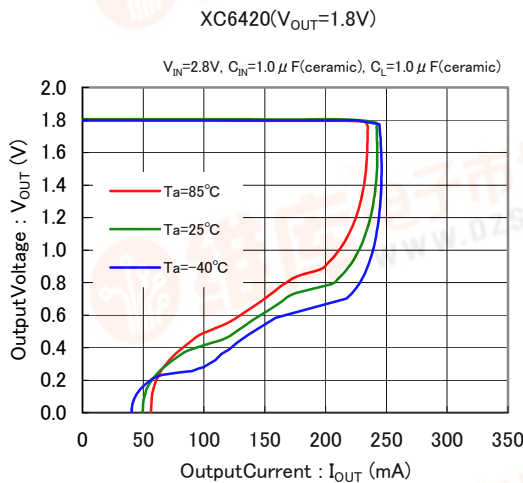
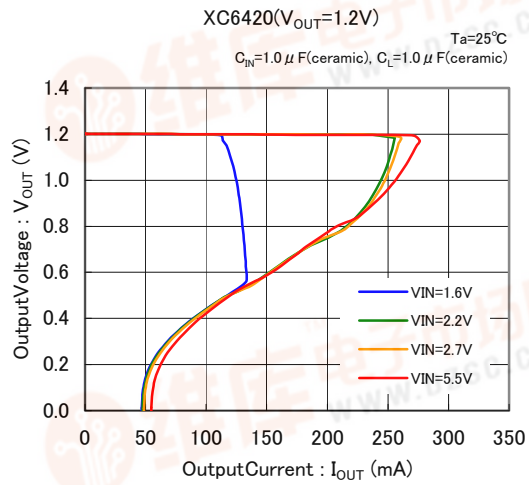
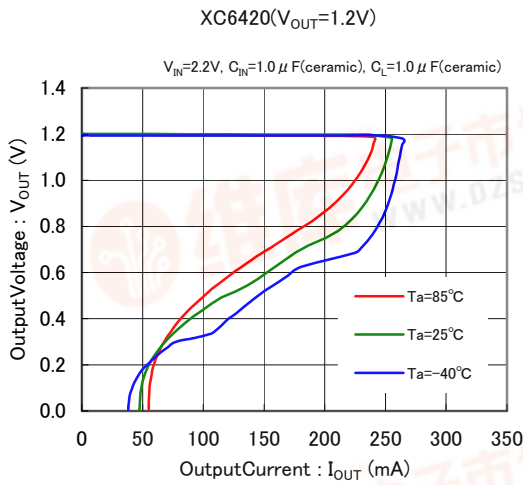

[查询XC6420供应商](#)

TYPICAL PERFORMANCE CHARACTERISTICS (Continued)

(1) Output Voltage vs. Output Current

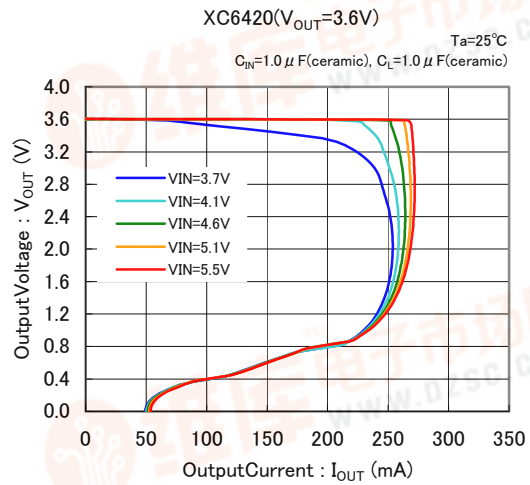
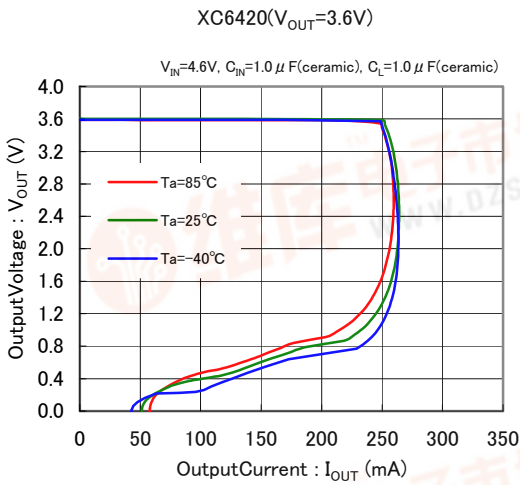

(2) Output Voltage vs. Input Voltage

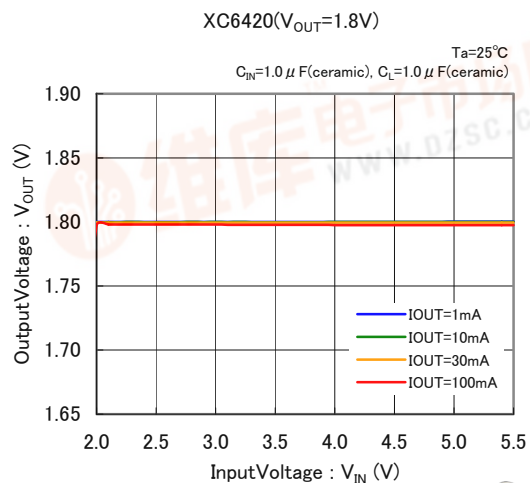
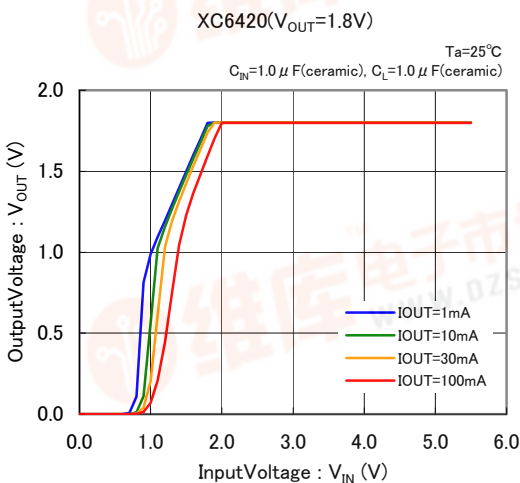
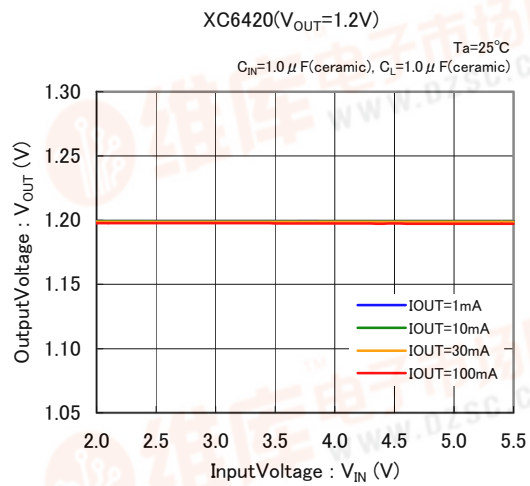
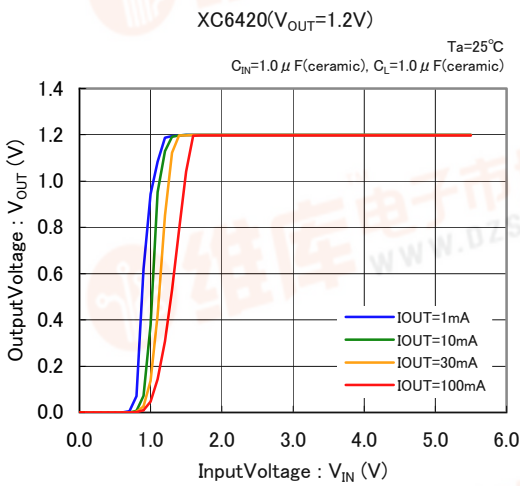

XC6420 Series

查询XC6420供应商

TYPICAL PERFORMANCE CHARACTERISTICS (Continued)

(2) Output Voltage vs. Input Voltage

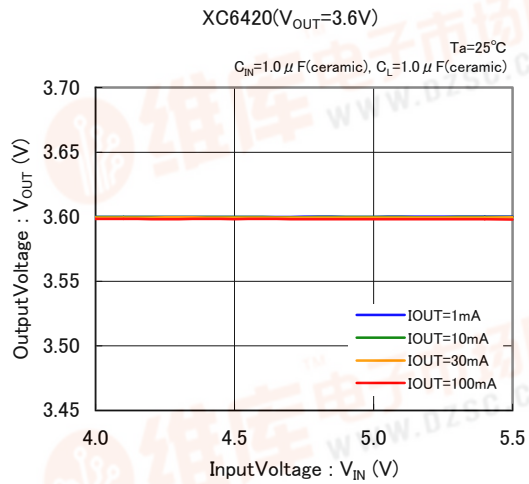
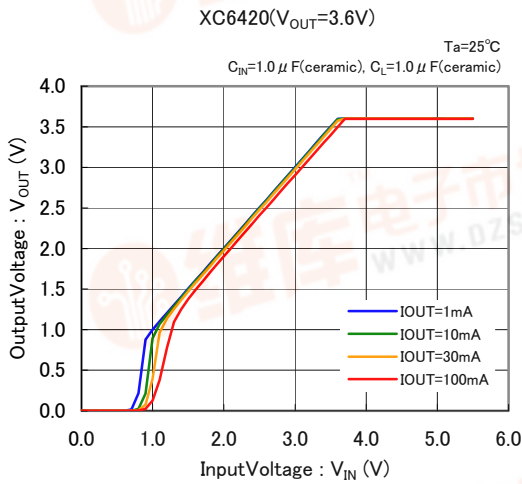
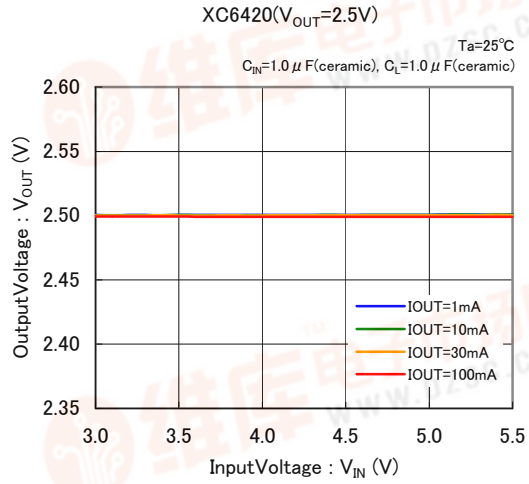
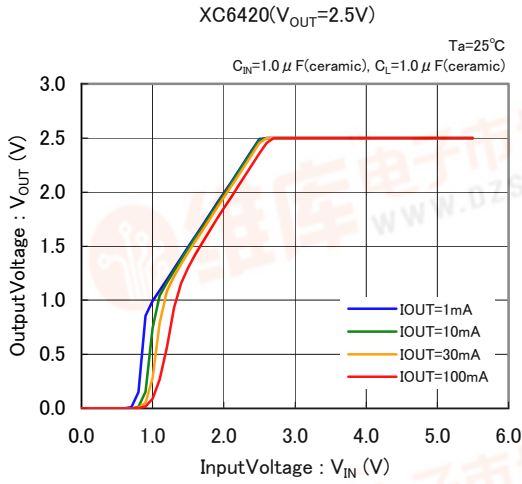

(3) Dropout Voltage vs. Output Current

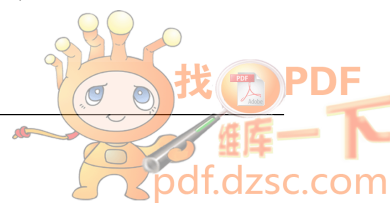
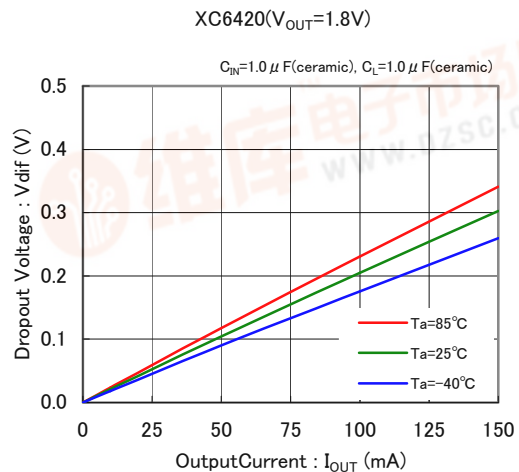
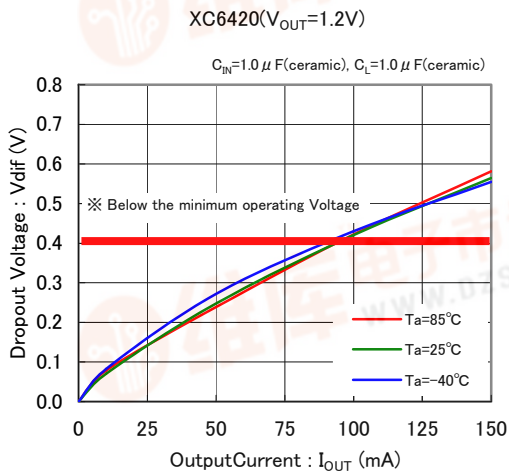

[查询XC6420供应商](#)

TYPICAL PERFORMANCE CHARACTERISTICS (Continued)

(3) Dropout Voltage vs. Output Current

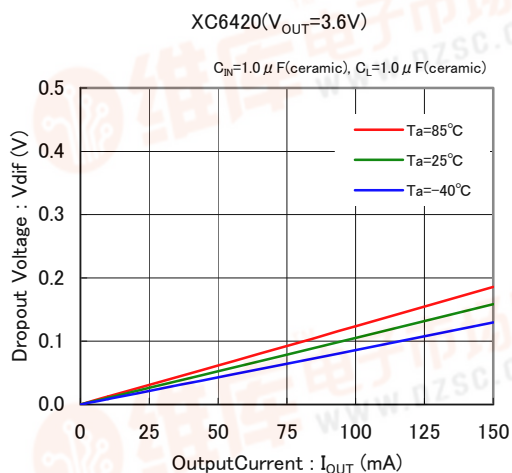
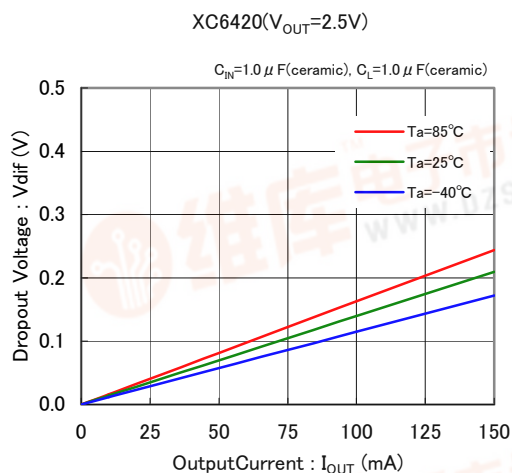

(4) Supply Current vs. Input Voltage

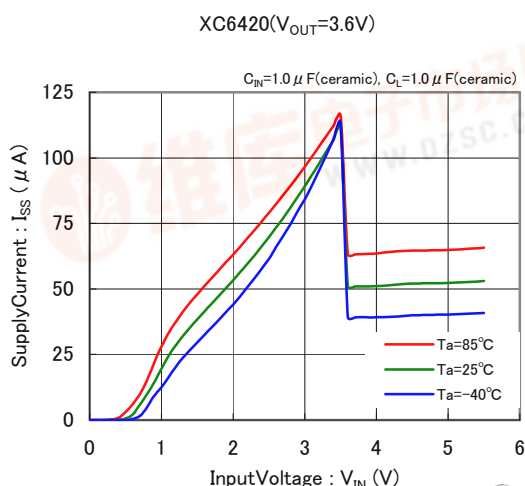
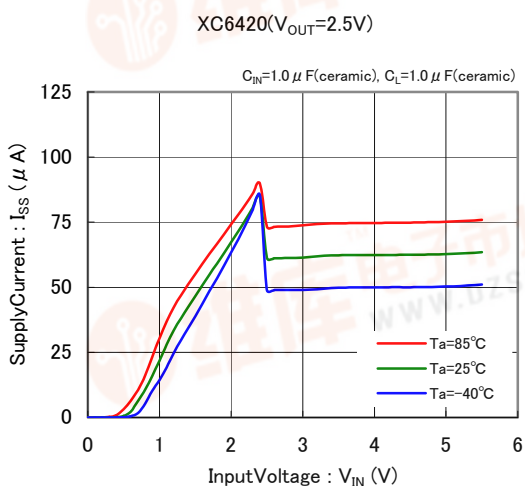
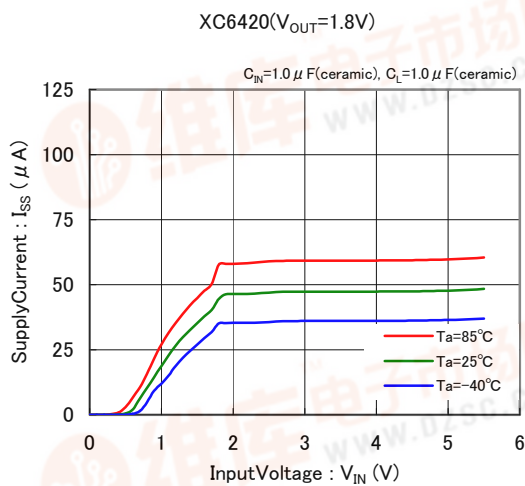
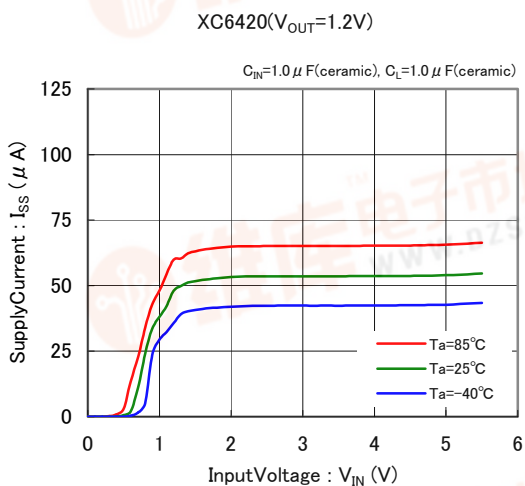

TYPICAL PERFORMANCE CHARACTERISTICS (Continued)

(5) Output Voltage vs. Ambient Temperature

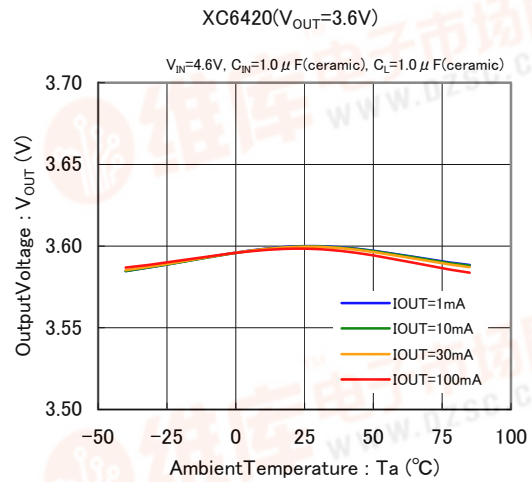
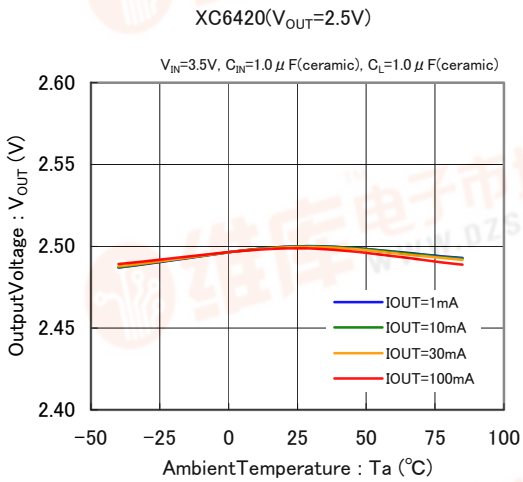
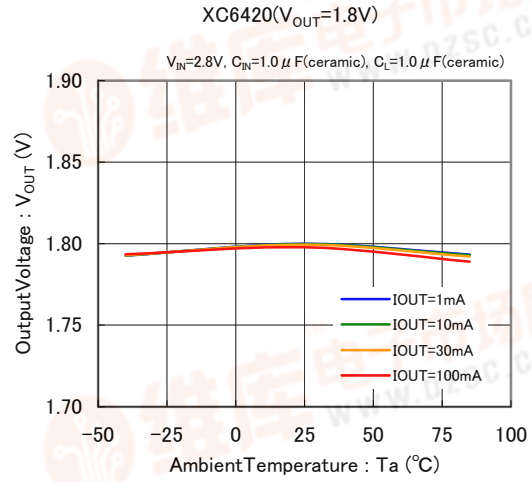
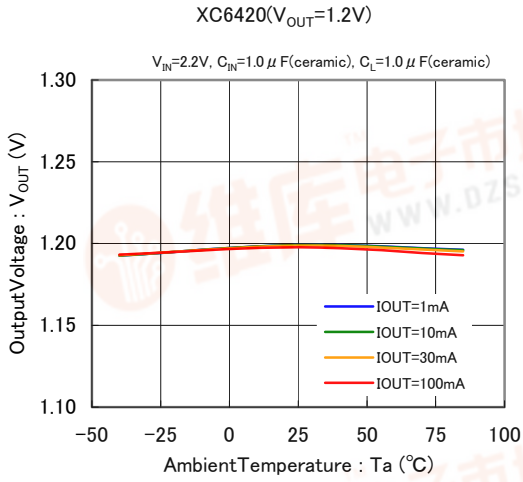

(6) Supply Current vs. Ambient Temperature

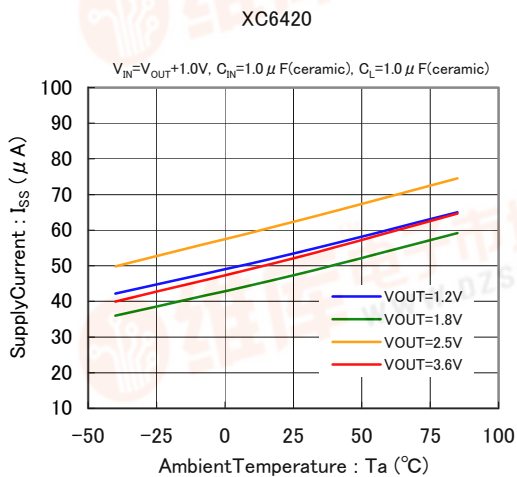

(7) EN Threshold Voltage vs. Ambient Temperature

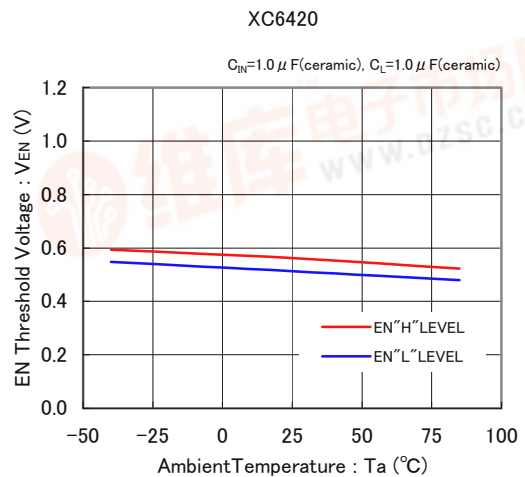

[查询XC6420供应商](#)

TYPICAL PERFORMANCE CHARACTERISTICS (Continued)

(8) Rising Response Time

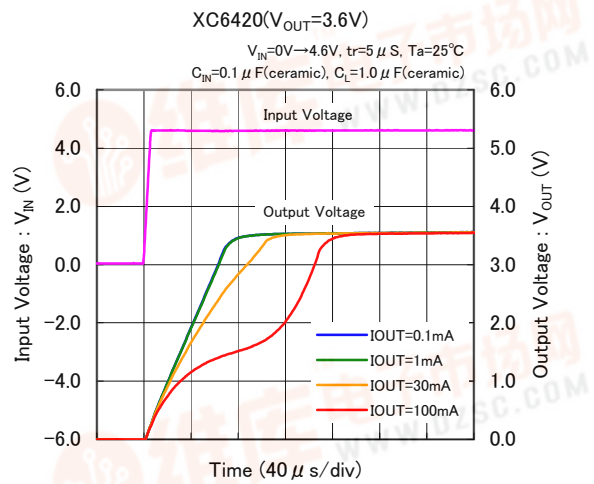
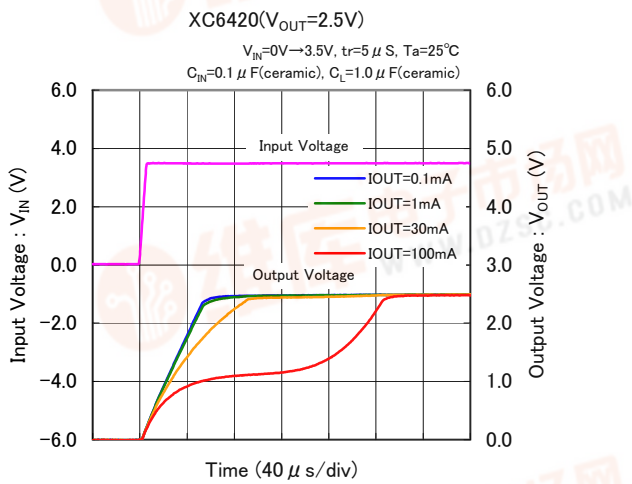
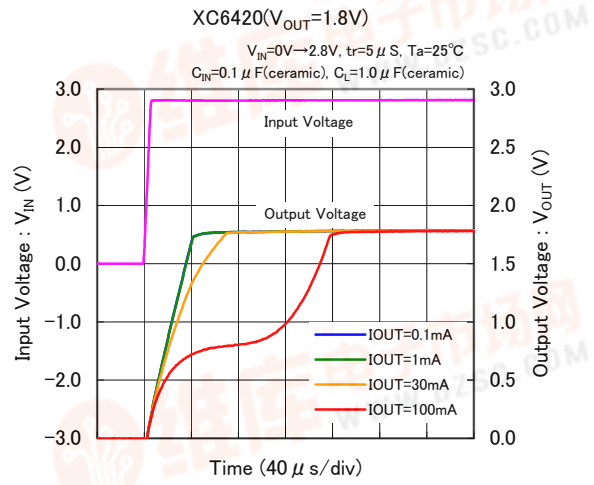
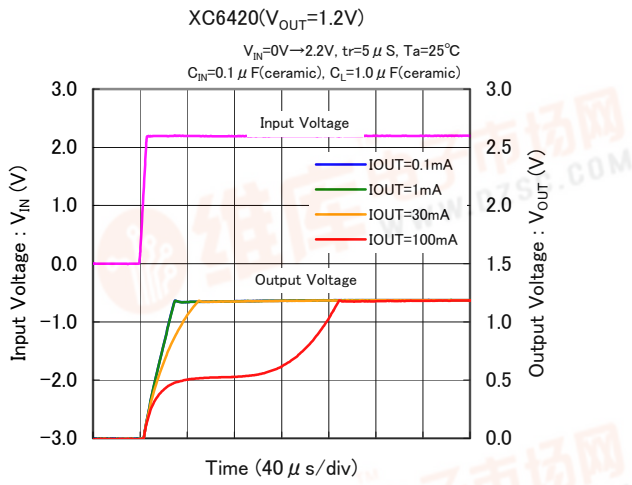

(9) Input Transient Response

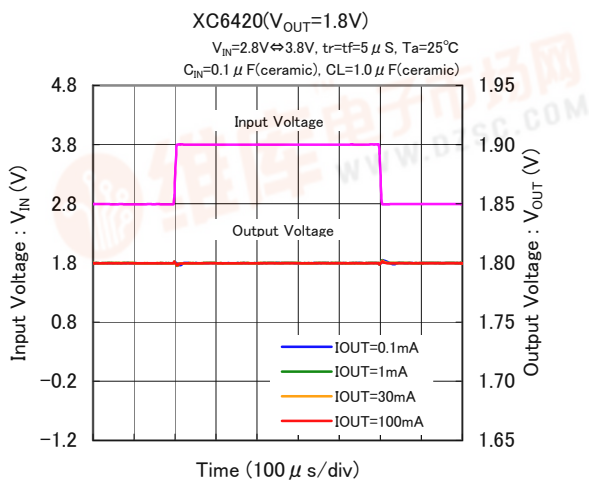
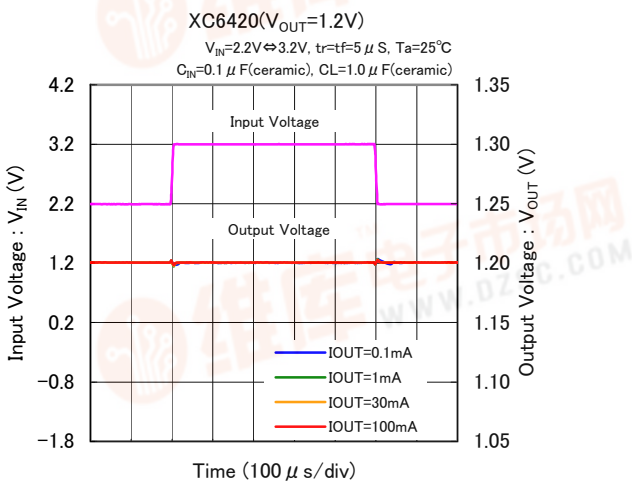

TYPICAL PERFORMANCE CHARACTERISTICS (Continued)

(9) Input Transient Response

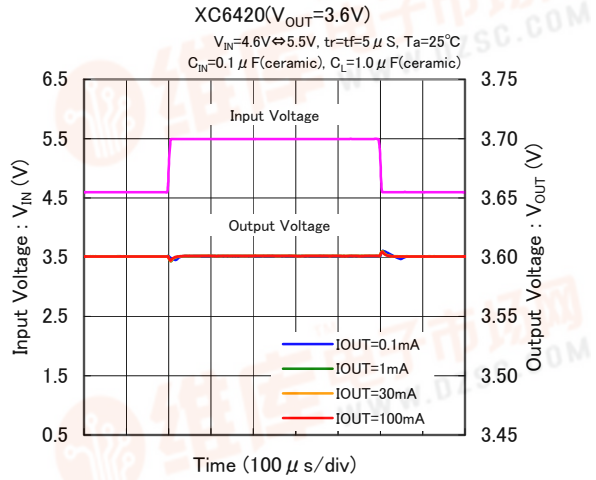
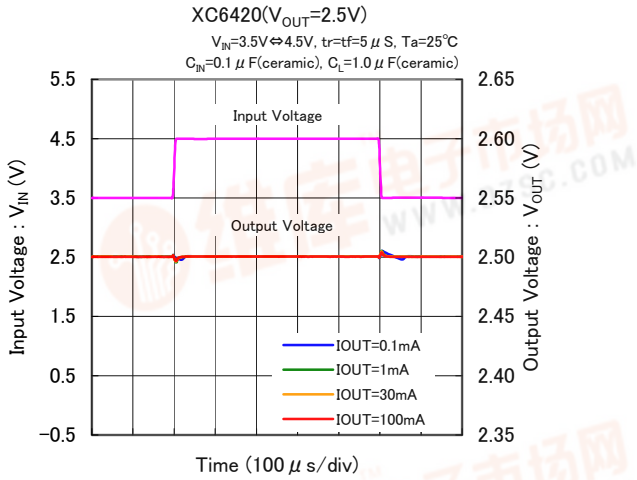

(10) Load Transient Response

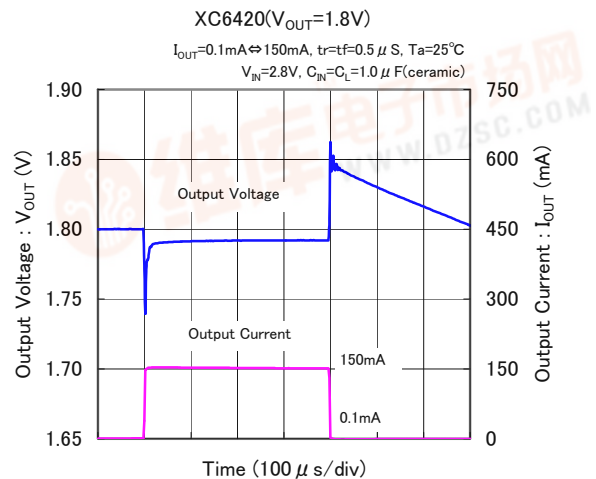
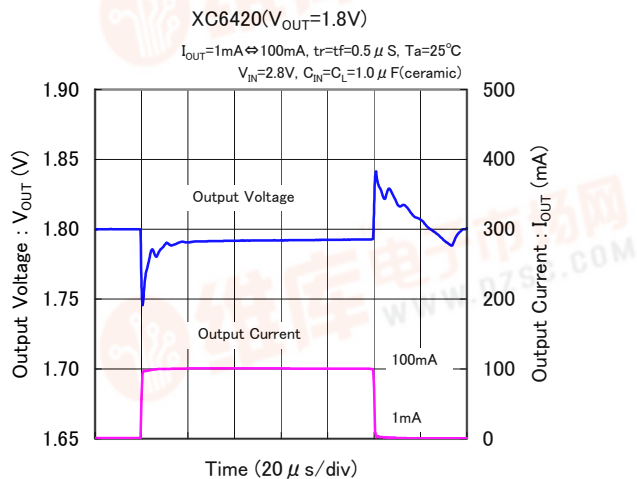
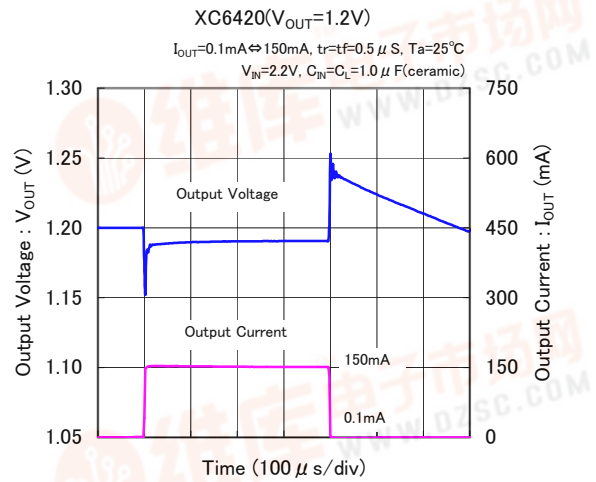
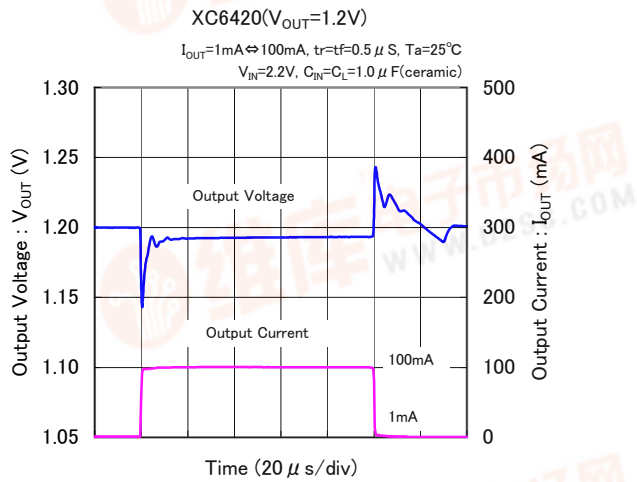

[查询XC6420供应商](#)

TYPICAL PERFORMANCE CHARACTERISTICS (Continued)

(10) Load Transient Response

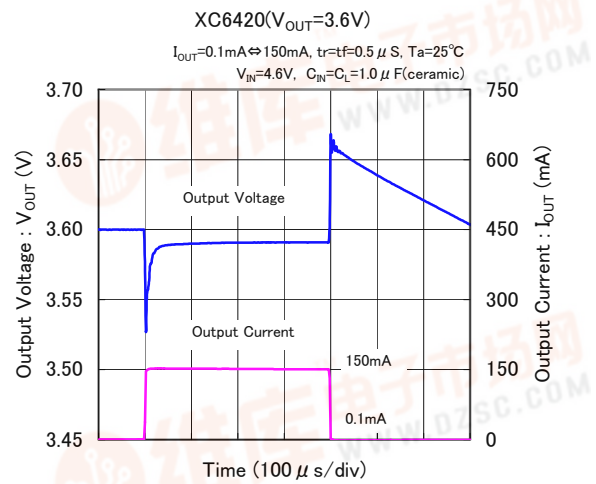
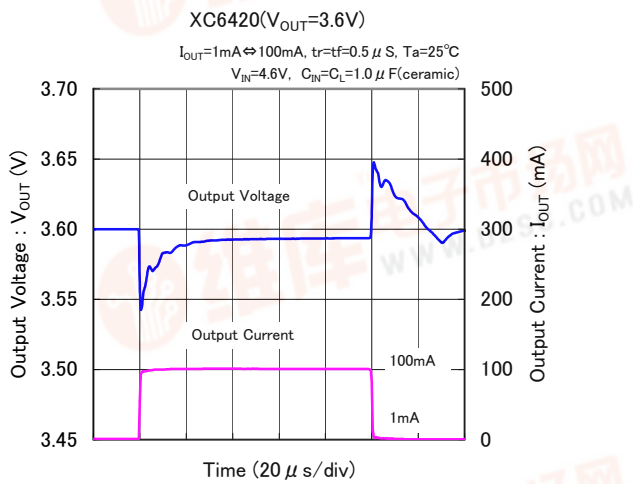
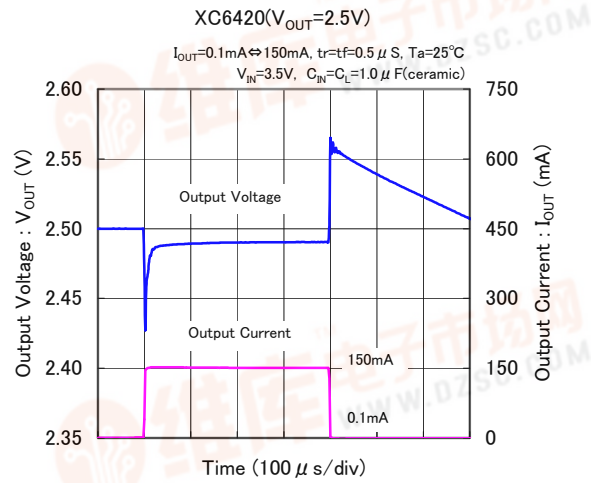
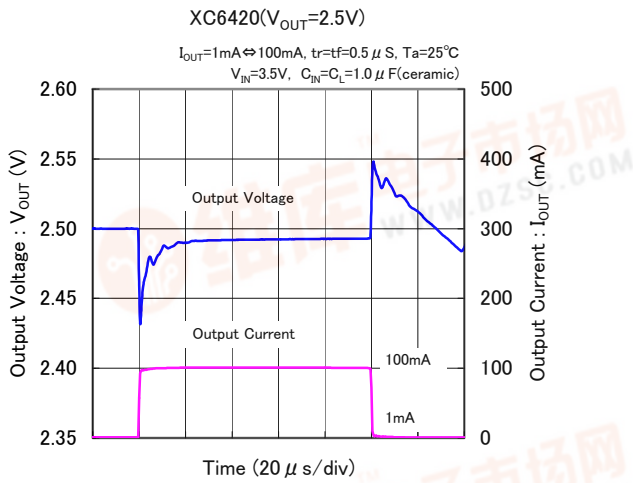

(11) EN Rising Respose Time

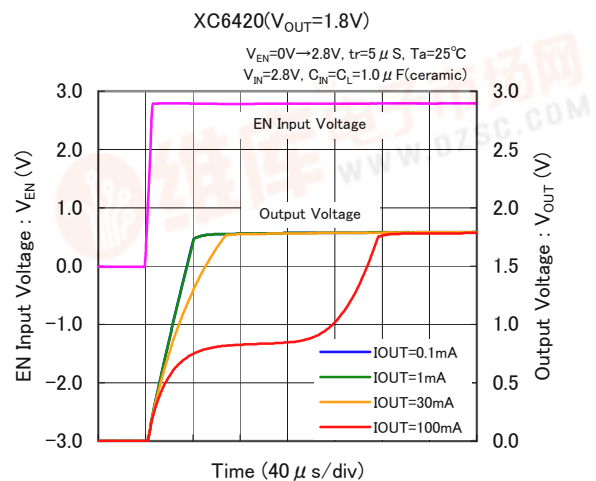
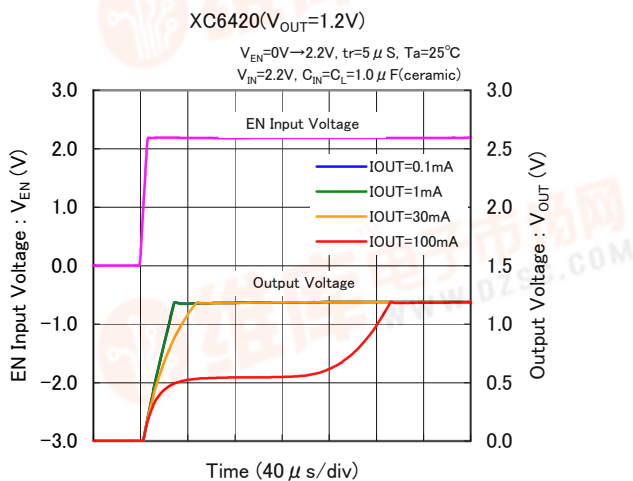

TYPICAL PERFORMANCE CHARACTERISTICS (Continued)

(11) EN Rising Respose Time

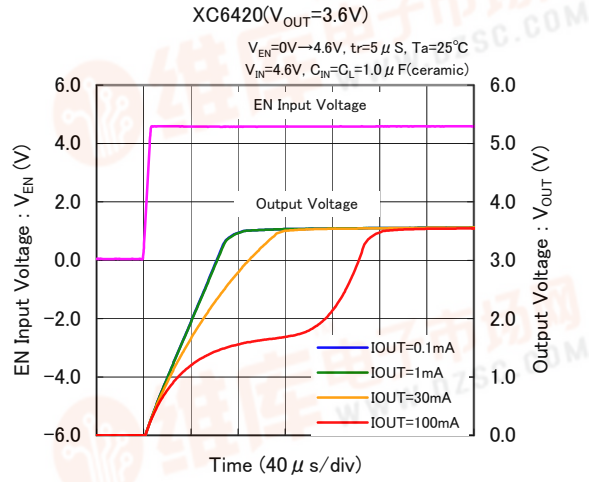
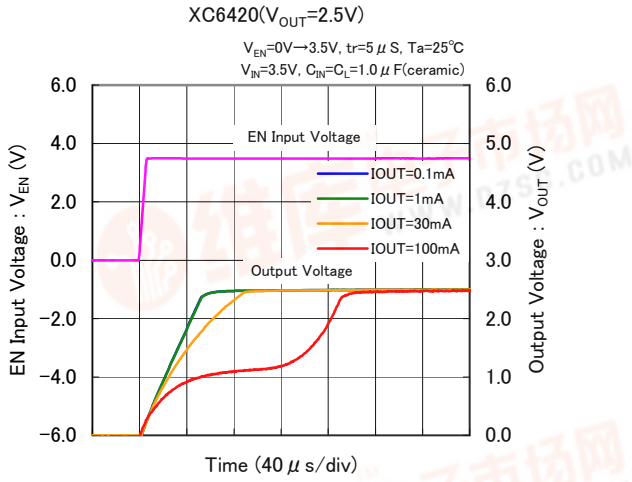

(12) Ripple Rejection

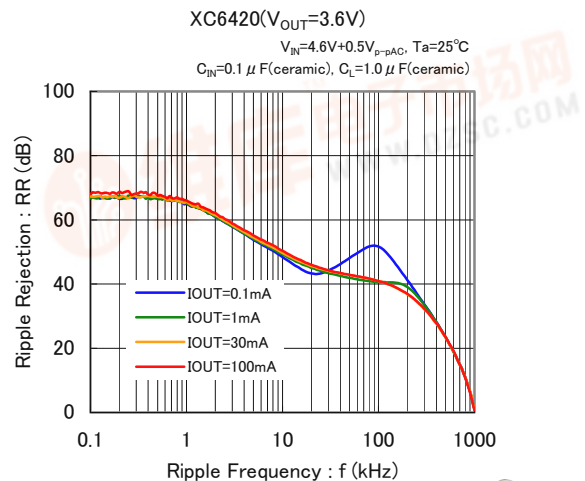
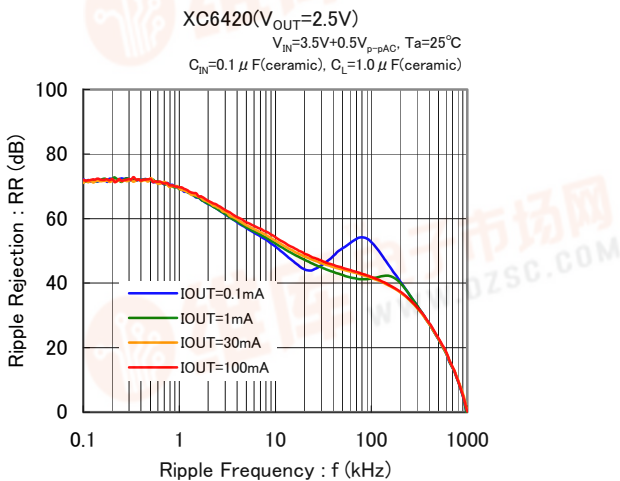
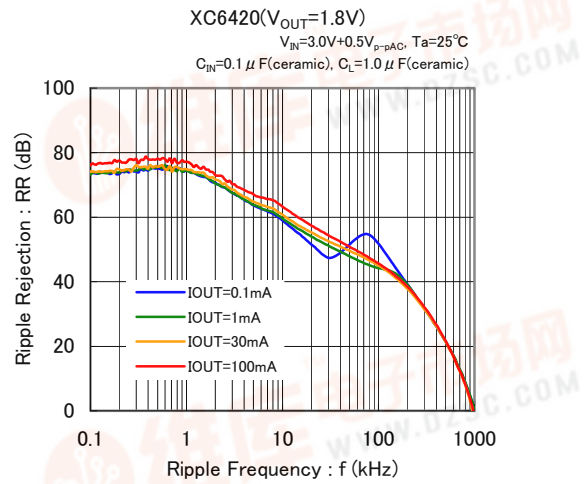
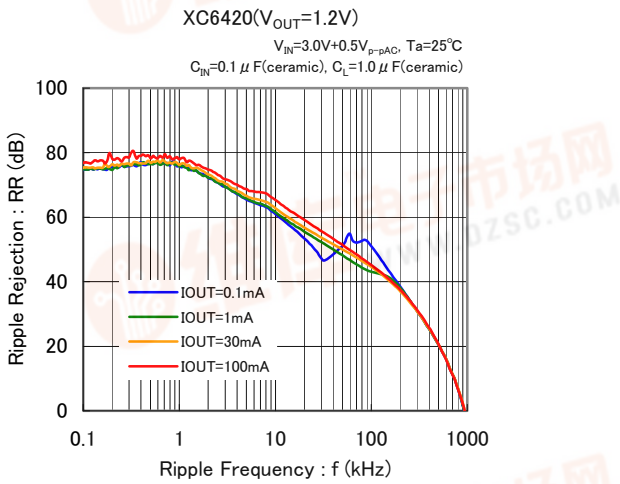

[查询XC6420供应商](#)

TYPICAL PERFORMANCE CHARACTERISTICS (Continued)

(13) Cross Talk

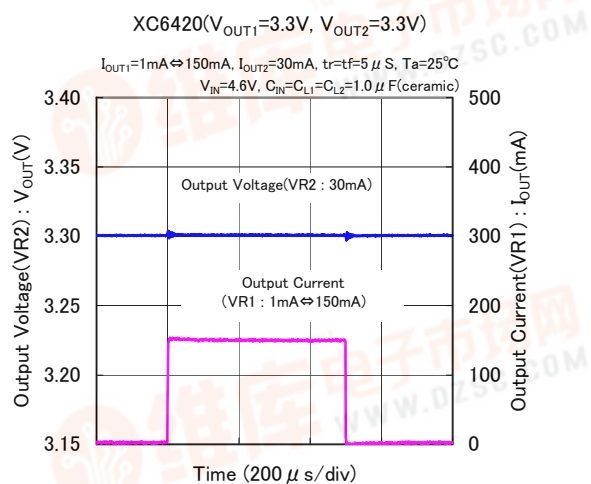
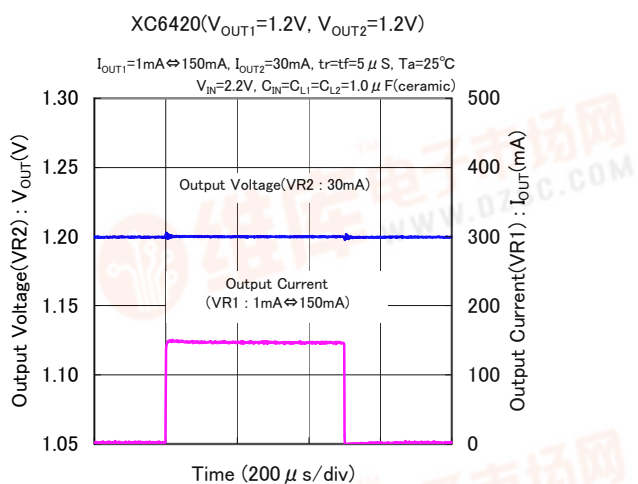

XC6420 Series

[查询XC6420供应商](#)

PACKAGING INFORMATION

SOT-26

(unit : mm)

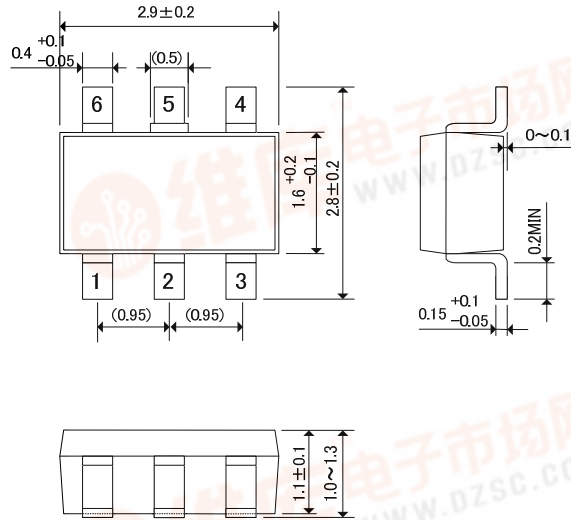

USPN-6

(unit : mm)

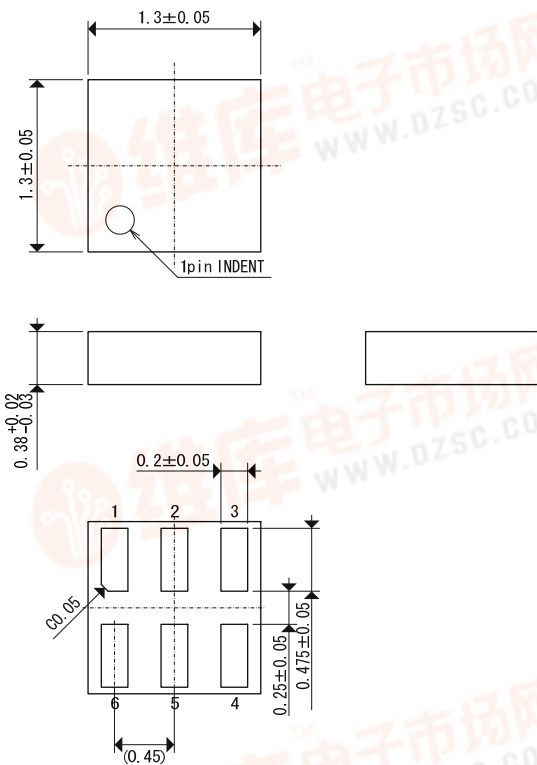

USPN-6 Reference Pattern Layout

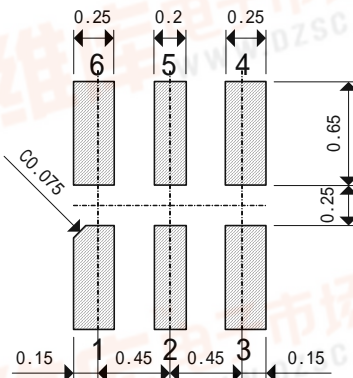

USPN-6 Reference Metal Mask Design

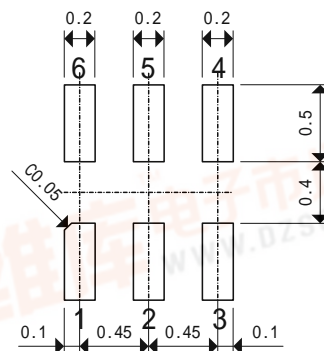

[查询XC6420供应商](#)

PACKAGING INFORMATION (Continued)

SOT-26 Power Dissipation

Power dissipation data for the SOT-26 is shown in this page.
The value of power dissipation varies with the mount board conditions.
Please use this data as one of reference data taken in the described condition.

1. Measurement Condition (Reference data)

- Condition: Mount on a board
- Ambient: Natural convection
- Soldering: Lead (Pb) free
- Board: Dimensions 40 x 40 mm (1600 mm² in one side)
Copper (Cu) traces occupy 50% of the board area
In top and back faces
Package heat-sink is tied to the copper traces
- Material: Glass Epoxy (FR-4)
- Thickness: 1.6 mm
- Through-hole: 4 x 0.8 Diameter

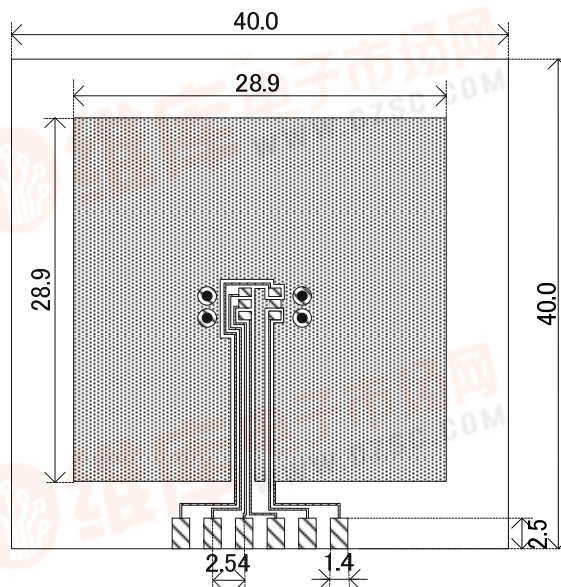

Evaluation Board (Unit: mm)

2. Power Dissipation vs. Ambient Temperature

Board Mount ($T_j \text{ max} = 125$)

| Ambient Temperature (°C) | Power Dissipation Pd (mW) | Thermal Resistance (°C/W) |
|--------------------------|---------------------------|---------------------------|
| 25 | 600 | 166.67 |
| 85 | 240 | |

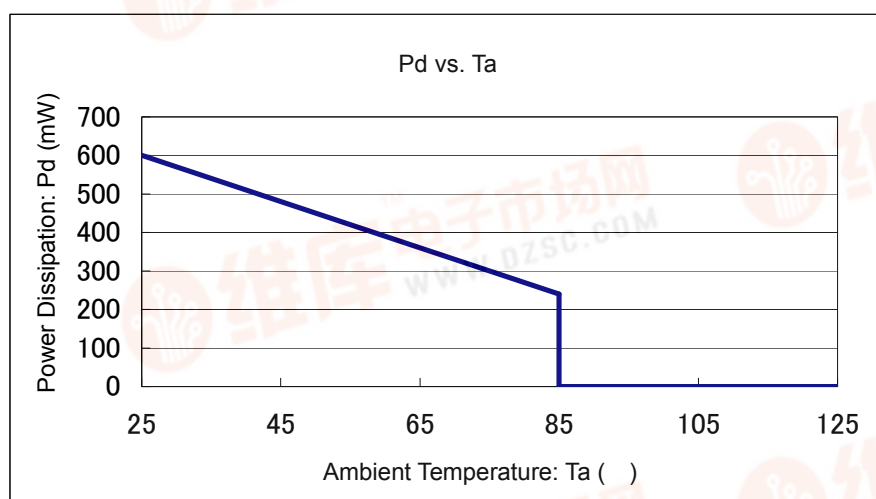

PACKAGING INFORMATION (Continued)

USPN-6 Power Dissipation

Power dissipation data for the USPN-6 is shown in this page.

The value of power dissipation varies with the mount board conditions.

Please use this data as one of reference data taken in the described condition.

1. Measurement Condition (Reference data)

- Condition: Mount on a board
- Ambient: Natural convection
- Soldering: Lead (Pb) free
- Board: 40 x 40 mm (1600 mm²)
4 Copper Layers
Each layer is connected to the package heat-sink and terminal pin No.1.
Each layer has approximately 800mm² copper area.
- Material: Glass Epoxy (FR-4)
- Thickness: 1.6 mm
- Through-hole: 4 x 0.8 Diameter

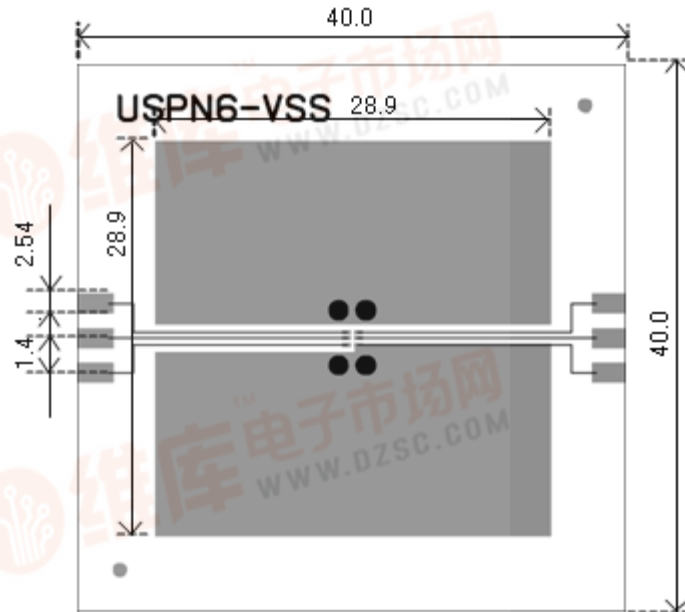

Evaluation Board (Unit: mm)

2. Power Dissipation vs. Ambient Temperature

Board Mount ($T_j \text{ max} = 125$)

| Ambient Temperature (°C) | Power Dissipation Pd (mW) | Thermal Resistance (°C/W) |
|--------------------------|---------------------------|---------------------------|
| 25 | 600 | 166.67 |
| 85 | 240 | |

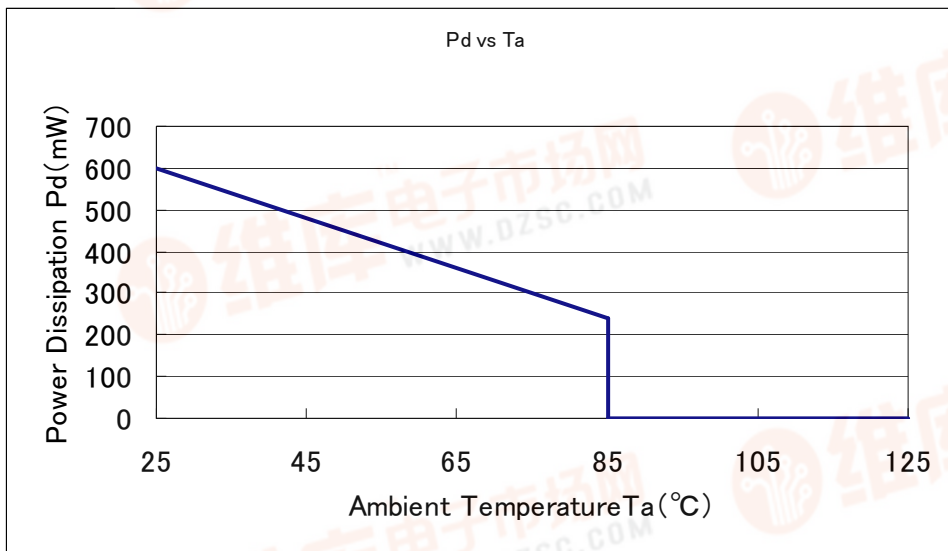

[查询XC6420供应商](#)

MARKING RULE

SOT-26

represents product series

| MARK | PRODUCT SERIES |
|------|----------------|
| 2 | XC6420*****-G |

represents output voltage
ex.)

| MARK | | PRODUCT SERIES |
|------|---|----------------|
| ② | ③ | |
| 0 | 1 | XC6420**01**-G |

④⑤ represents production lot number.
01 to 09, 0A to 0Z, 11 to 9Z, A1 to A9, AA to Z9, ZA to ZZ in order.
(G, I, J, O, Q, W excepted)
*No character inversion used.

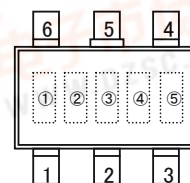

SOT-26
(TOP VIEW)

USPN-6

represents internal sequential number

③④ represents production lot number.
01 to 09, 0A to 0Z, 11 to 9Z, A1 to A9, AA to Z9, ZA to ZZ in order.
(G, I, J, O, Q, W excepted)
*No character inversion used.

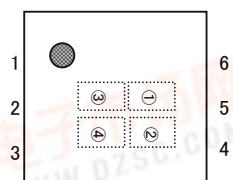

USPN-6
(TOP VIEW)

1. The products and product specifications contained herein are subject to change without notice to improve performance characteristics. Consult us, or our representatives before use, to confirm that the information in this datasheet is up to date.
2. We assume no responsibility for any infringement of patents, patent rights, or other rights arising from the use of any information and circuitry in this datasheet.
3. Please ensure suitable shipping controls (including fail-safe designs and aging protection) are in force for equipment employing products listed in this datasheet.
4. The products in this datasheet are not developed, designed, or approved for use with such equipment whose failure or malfunction can be reasonably expected to directly endanger the life of, or cause significant injury to, the user.
(e.g. Atomic energy; aerospace; transport; combustion and associated safety equipment thereof.)
5. Please use the products listed in this datasheet within the specified ranges.
Should you wish to use the products under conditions exceeding the specifications, please consult us or our representatives.
6. We assume no responsibility for damage or loss due to abnormal use.
7. All rights reserved. No part of this datasheet may be copied or reproduced without the prior permission of TOREX SEMICONDUCTOR LTD.

TOREX SEMICONDUCTOR LTD.