

Full Color PLCC6 LED

[查询"OVSTRGBBCR8"供应商](#)

OVSTRGBBCR8

- Full-color red/green/blue
- PLCC package with 6 pins
- Wide viewing angle
- High performance
- Tuneable color mix

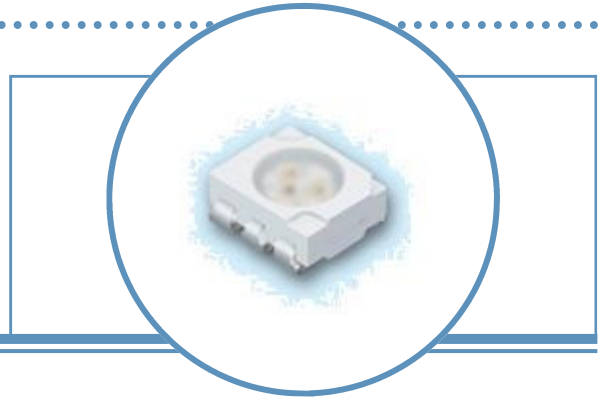

The **OVSTRGBBCR8** package design provides wide viewing angle, low power consumption, and high luminous intensity. Color on demand is made possible by isolated chip circuits, allowing each LED to be driven individually or in tuneable color combinations.

Applications

- Amusement equipment
- Information boards
- Automotive interior lighting
- Portable appliances
- Indoor and outdoor displays
- Backlighting
- Camera flash
- RGB full-color displays

Part Number	Chip				Lens Color
	Type	Material	Emitted Color	Intensity Typ. mcd	
OVSTRGBBCR8	R	AlInGaP	Red	1000	Water Clear
	G	InGaN	Green	900	
	B	InGaN	Blue	280	

RECOMMENDED PWB PATTERN FOR SOLDERING

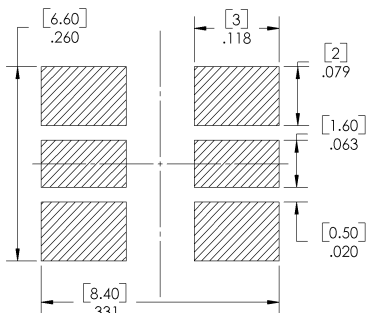

PIN CONNECTIONS

GREEN 1 —▶— 4 GREEN

RED 2 —▶— 5 RED

BLUE 3 —▶— 6 BLUE

1,2,3 ANODE 4,5,6 CATHODE

DIMENSIONS ARE IN INCHES AND [MILLIMETERS].

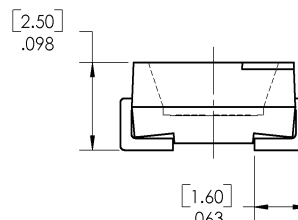
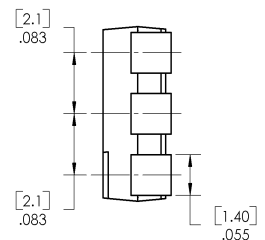
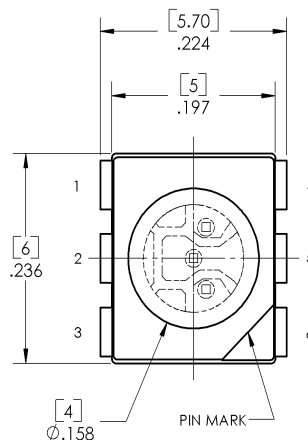

DO NOT LOOK DIRECTLY AT LED WITH UNSHIELDED EYES OR DAMAGE TO RETINA MAY OCCUR.

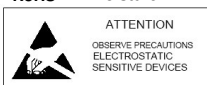

OPTEK reserves the right to make changes at any time in order to improve design and to supply the best product possible.

Full Color PLCC6 LED

OPSTRGBBCR8 供应商



Absolute Maximum Ratings

T_A = 25° C unless otherwise noted

PARAMETER	RATING			UNIT
	R	G	B	
Storage Temperature	-40 ~ +100			°C
Operating Temperature	-40 ~ +100			°C
Reverse Voltage	5			V
Continuous Forward Current ¹	80	80	80	mA
Peak Forward Current (10% Duty Cycle, PW ≤ 100 μsec)	200	100	100	mA
Power Dissipation	260	410	410	mW
Junction Temperature	110	110	110	°C
Junction/ambient (1 chip on ²)	250	210	210	°C/W
Junction/ambient (3 chips on ²)	500	300	300	°C/W
Junction/solder point (1 chip on)	150	130	130	°C/W
Junction/solder point (3 chips on)	150	160	160	°C/W

Notes:

1. Single color light
2. Rth test condition: Mounted on PC Board FR 4 (pad size ≥ 40mm²)

Electrical Characteristics

T_A = 25° C unless otherwise noted

SYMBOL	PARAMETER	VALUES			UNIT	CONDITIONS	
			R	G			B
I _V	Luminous Intensity	Min	710	710	180	mcd	I _F = 50 mA
		Avg	1000	900	280		
V _F	Forward Voltage	Avg	2.5	4.5	4.5	V	I _F = 50 mA
		Max	3.2	5.1	5.1		
I _R	Reverse Current (max)		10	10	10	μA	V _R = 5 V
λ _D	Dominant Wavelength		624	525	470	nm	I _F = 50 mA
λ _P	Wavelength at Peak Emission		620	521	468	nm	I _F = 50 mA
2 Θ _{1/2}	50% Power Angle		120	120	120	deg	I _F = 50 mA
Δλ	Spectrum Radiation Bandwidth		24	38	28	nm	I _F = 50 mA

OPTEK reserves the right to make changes at any time in order to improve design and to supply the best product possible.

Full Color PLCC6 LED

OVSTRGBBCR8
[查询"OVSTRGBBCR8"供应商](#)

Standard Bins ($I_F = 50 \text{ mA}$)

Lamps are sorted to luminous intensity (I_V) and dominant wavelength (λ_D) bins shown. Orders for OVSTRGBBCR8 may be filled with any or all bins contained as below.

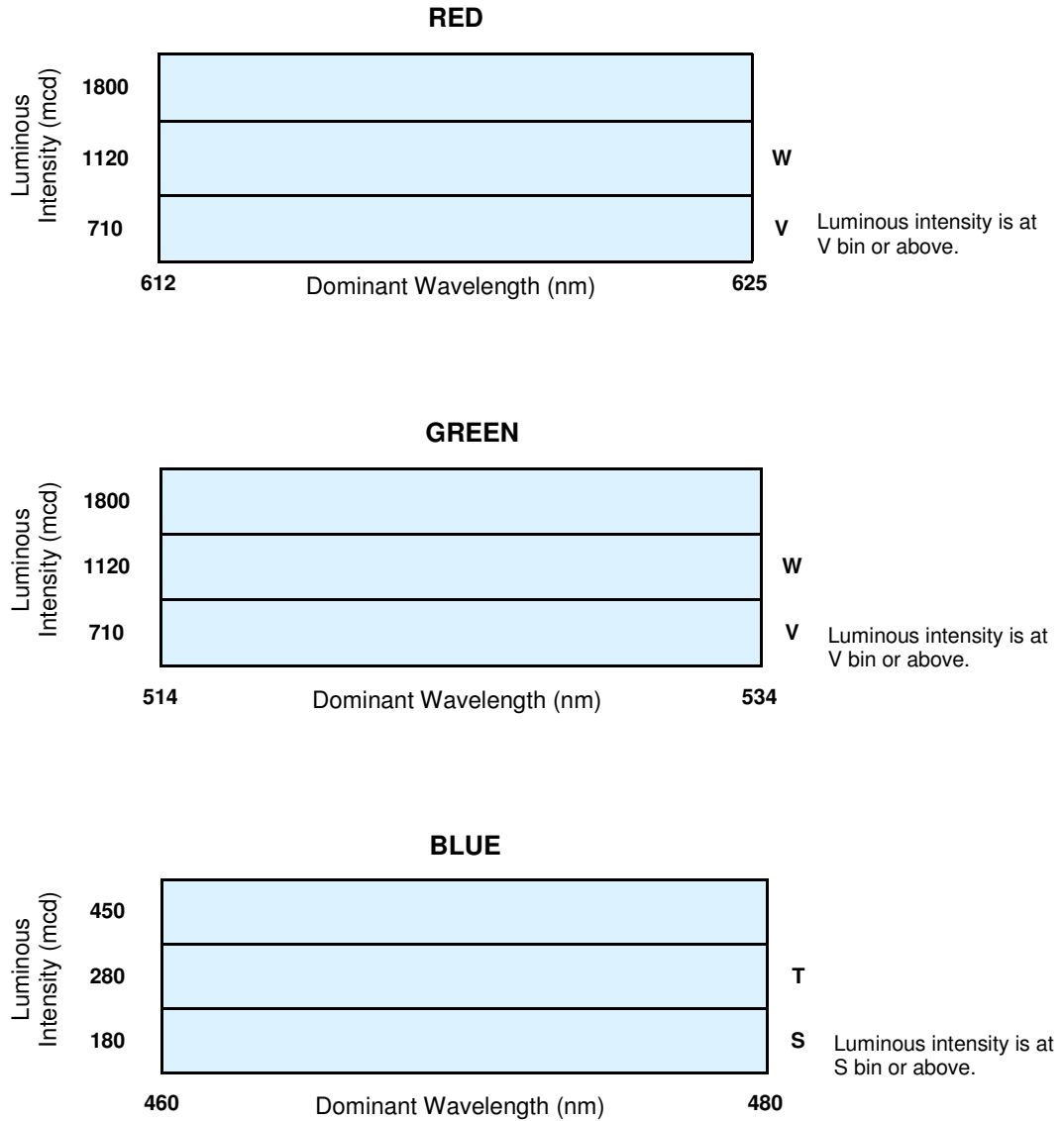

Notes:

1. All ranks will be included per delivery, rank ratio will be based on the chip distribution.
2. Tolerance of measurement of luminous intensity is $\pm 10\%$.
3. Tolerance of measurement of dominant wavelength is $\pm 1 \text{ nm}$.
4. Tolerance of measurement of V_F is $\pm 0.05 \text{ V}$.

OPTEK reserves the right to make changes at any time in order to improve design and to supply the best product possible.

Typical Electro-Optical Characteristics Curves

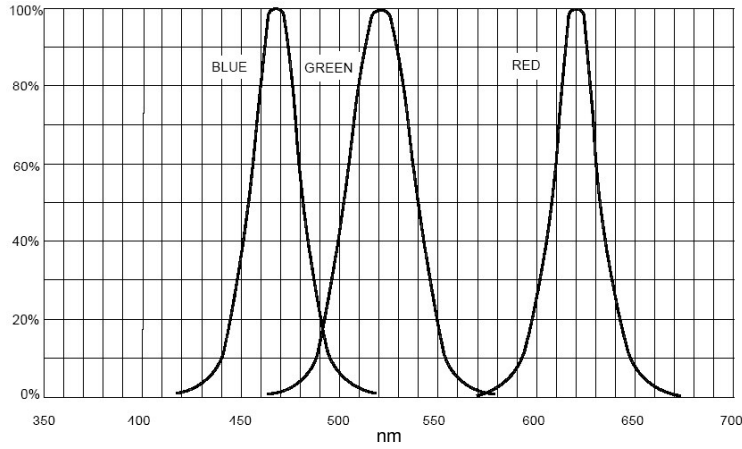

Relative Intensity vs Dominant Wavelength

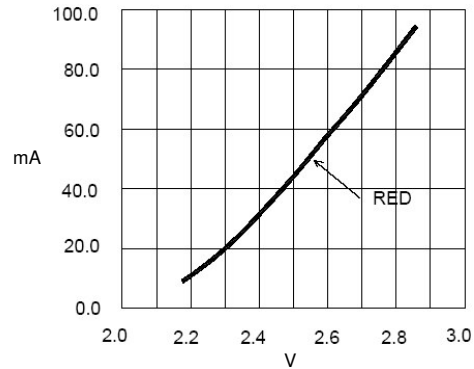
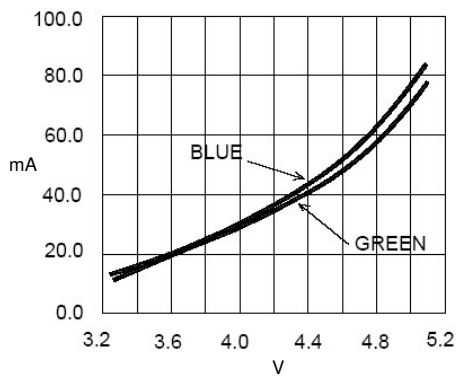

Forward Current vs Forward Voltage

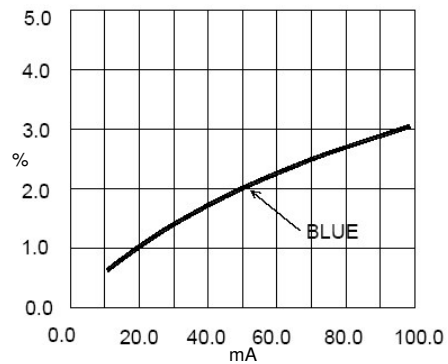
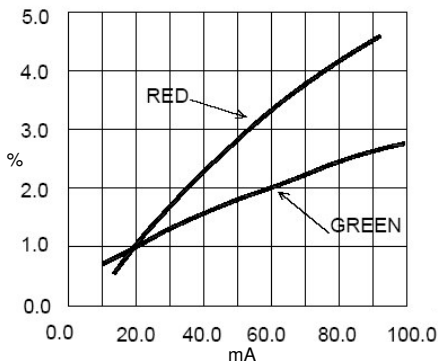

Relative Luminous Intensity vs Forward Current

OPTEK reserves the right to make changes at any time in order to improve design and to supply the best product possible.

Typical Electro-Optical Characteristics Curves

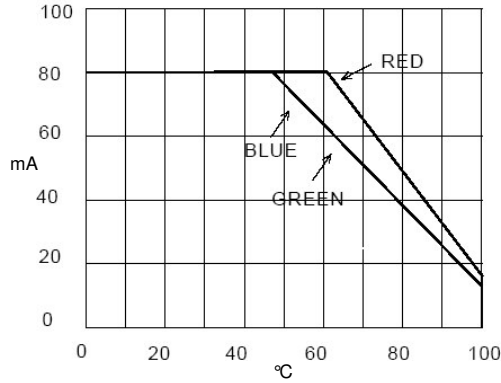

Maximum Forward DC Current vs Solder Point Temperature

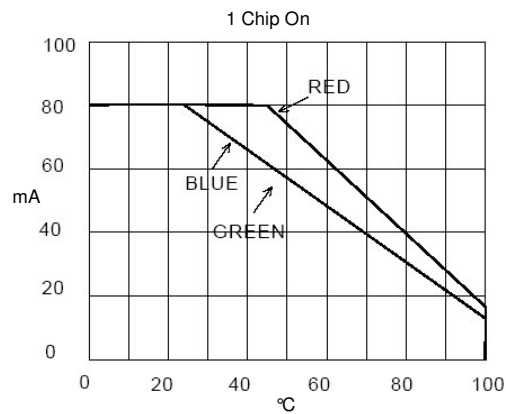
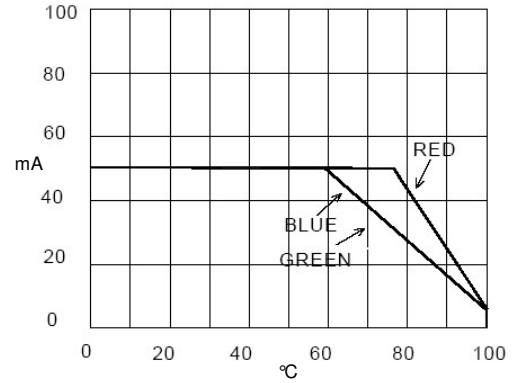

Maximum Forward DC Current vs Ambient Temperature

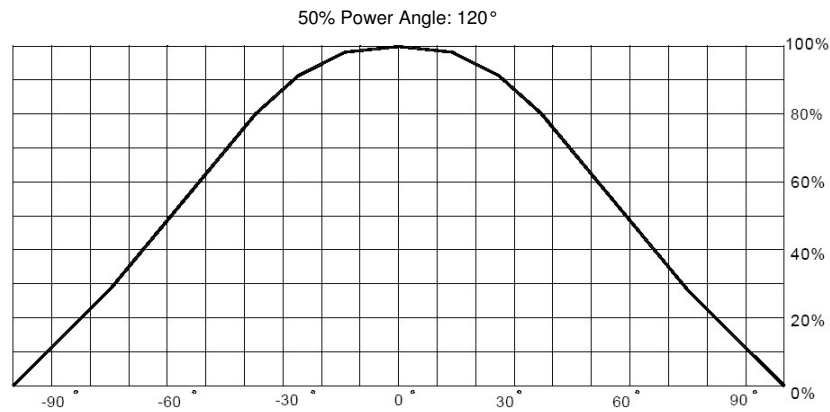
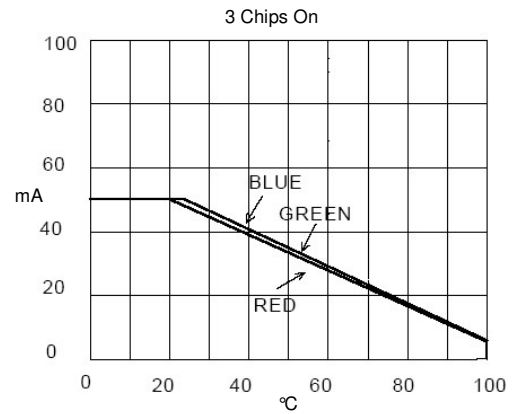

Far Field Pattern

OPTEK reserves the right to make changes at any time in order to improve design and to supply the best product possible.

CIE Chromaticity Diagram

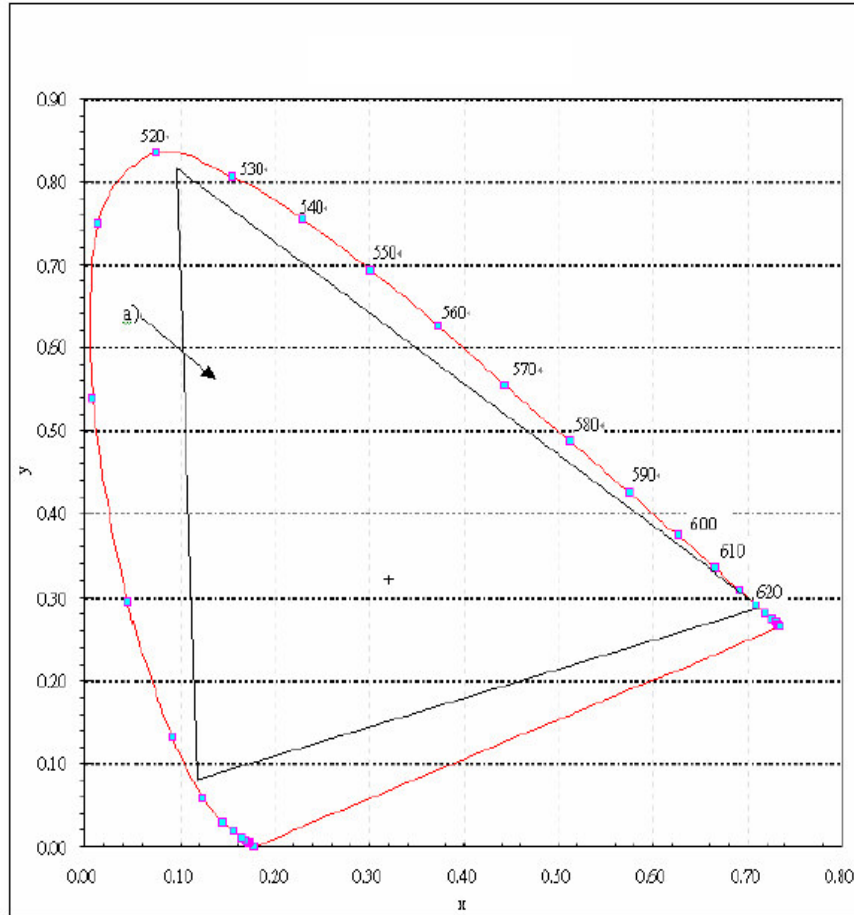

Note:

1. The color coordinates of the mixed light can be expected within the area of the color triangle marked a). The achromatic point ($x=0.33$, $y=0.33$) is marked "+".

OPTEK reserves the right to make changes at any time in order to improve design and to supply the best product possible.

Full Color PLCC6 LED

查询“OVSTRGBB6CR8”供应商

Reel Dimensions: 13-inch reel

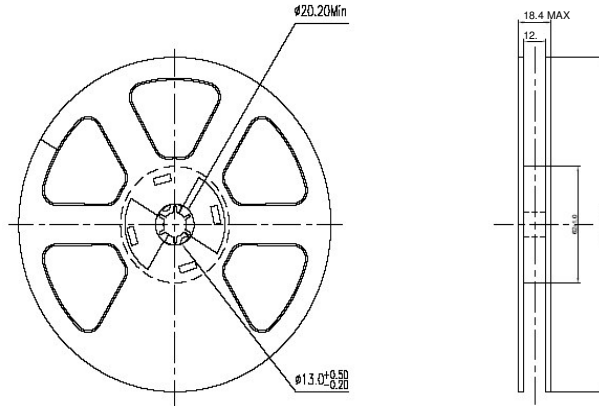

Carrier Tape Dimensions: Loaded quantity 2000 pieces per reel

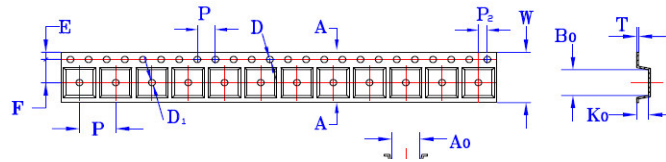

ITEM	W	A ₀	B ₀	K ₀	T	P	F	E	D	D ₁	P ₀	P ₂
DIM	12.0 ^{+0.30} _{-0.10}	6.12 ^{+0.10} _{-0.10}	6.12 ^{+0.10} _{-0.10}	2.64 ^{+0.10} _{-0.10}	0.305 ^{+0.02} _{-0.02}	8.00 ^{+0.10} _{-0.10}	5.50 ^{+0.10} _{-0.10}	1.75 ^{+0.10} _{-0.10}	φ1.50 ^{+0.10} _{-0.00}	φ1.50MIN	4.00 ^{+0.10} _{-0.10}	2.00 ^{+0.05} _{-0.05}

Notes:

1. 10 sprocket hole pitch cumulative tolerance ± 0.20 mm.
2. Carrier camber not to exceed 1mm in 100 mm.
3. A₀ and B₀ measured on a plane 0.3 mm above the bottom of the pocket.
4. K₀ measured from a p lane on the inside bottom of the pocket to the top surface of the carrier.
5. All dimensions meet EIA-481-2A requirements.
6. Material: Black Anti-static Polystyrene.
7. Thickness: 0.305 \pm 0.02 mm.

Moisture Resistant Packaging

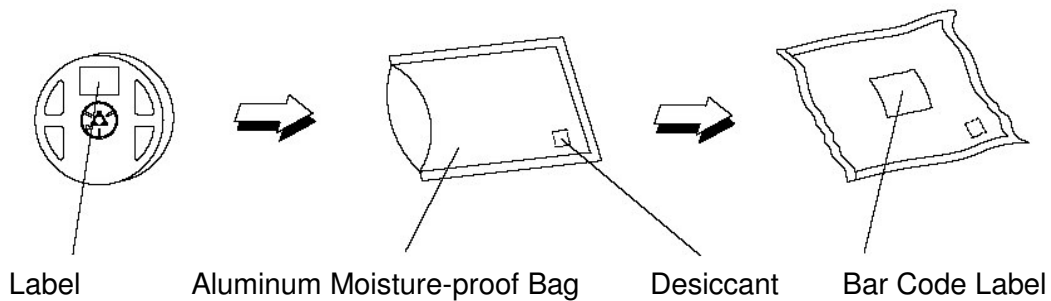

OPTEK reserves the right to make changes at any time in order to improve design and to supply the best product possible.