



December 1996

LM2408 Monolithic Triple 4.5 ns CRT Driver

General Description

The LM2408 is an integrated high voltage CRT driver circuit designed for use in color monitor applications. The IC contains three high input impedance, wide band amplifiers which directly drive the RGB cathodes of a CRT. The gain of each channel is internally set at -15 and can drive CRT capacitive loads as well as resistive loads presented by other applications, limited only by the package's power dissipation.

The IC is packaged in an industry standard 11-Lead TO-220 molded plastic power package. See thermal considerations on page 5.

Features

- Rise/fall times typically 4.5 ns with 8 pF load
- Output swing capability: 50 V_{PP} for V_{CC} = 80
40 V_{PP} for V_{CC} = 70
30 V_{PP} for V_{CC} = 60
- Pinout designed for easy PCB layout
- 1V to 7V input range
- Stable with 0 pF–20 pF capacitive loads
- Convenient TO-220 staggered lead package style

Applications

- CRT driver for 1280 × 1024 (Non-interfaced) and XGA display resolution color monitors
- Pixel clock frequency up to 160 MHz

Schematic and Connection Diagrams

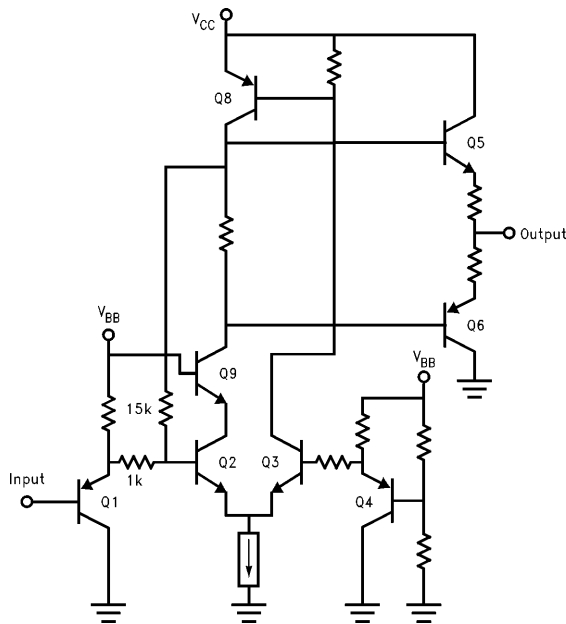
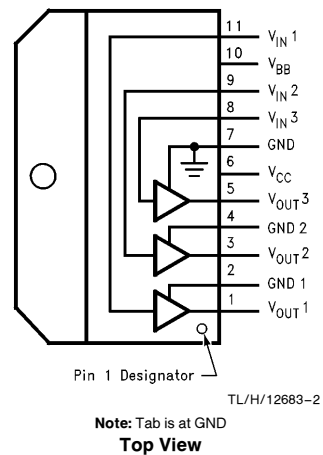

FIGURE 1. Simplified Schematic Diagram (One Channel)



LM2408 Monolithic Triple 4.5 ns CRT Driver

Absolute Maximum Ratings

(Notes 1 and 3)

Supply Voltage (V_{CC})	+95V
Bias Voltage (V_{BB})	+16V
Input Voltage (V_{IN})	-0.5V to $V_{BIAS} + 0.5V$
Storage Temperature Range (T_{STG})	-65°C to +150°C
Lead Temperature (Soldering, <10 sec.)	300°C
ESD Tolerance	2 kV

Operating Ranges (Note 2)

V_{CC}	+60V to +85V
V_{BB}	+8V to +15V
V_{IN}	+1V to +7V
Case Temperature (T_{CASE})	-20°C to +100°C

Do not operate the part without a heat sink.

Electrical Characteristics

Unless otherwise noted: $V_{CC} = +80V$, $V_{BB} = +12V$, $V_{IN} = +3.2V$ (at LM2408 input pins), $C_L = 8\text{ pF}$, Output = 40 V_{PP} at 1 MHz, $T_A = 25^\circ\text{C}$.

Symbol	Parameter	Conditions	LM2408			Units
			Min	Typical	Max	
I_{CC}	Supply Current	Per Channel, No Output Load		22	30	mA
I_{BB}	Bias Current			21		mA
V_{OUT}	DC Output Voltage	No Input Signal	47	50	53	V_{DC}
A_V	DC Voltage Gain	No Input Signal	-13	-15	-17	
ΔA_V	Gain Matching	(Note 4)		1.0		dB
LE	Linearity Error	(Notes 4, 5)		8		%
t_R	Rise Time	10% to 90%, $f = 1\text{ MHz}$		4.5		ns
t_F	Fall Time	90% to 10%, $f = 1\text{ MHz}$		4.5		ns

Note 1: Absolute Maximum Ratings indicate limits beyond which damage to the device may occur.

Note 2: Operating ratings indicate conditions for which the device is functional, but do not guarantee specific performance limits. For guaranteed specifications and test conditions, see the Electrical Characteristics. The guaranteed specifications apply only for the test conditions listed. Some performance characteristics may change when the device is not operated under the listed test conditions.

Note 3: All voltages are measured with respect to GND, unless otherwise specified.

Note 4: Calculated value from Voltage Gain test on each channel.

Note 5: Linearity Error is defined as the variation in DC gain from $V_{IN} = +1.90V$ to $V_{IN} = +4.50V$.

Note 6: Input from signal generator: $t_R, t_F < 1\text{ ns}$.

AC Test Circuit

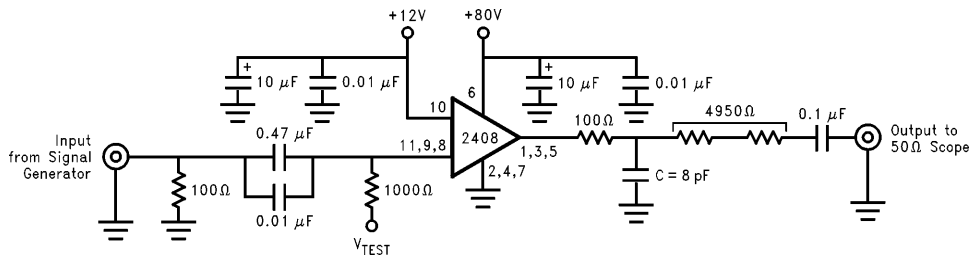

TL/H/12683-3

Note: 8 pF is total load plus parasitic capacitance.

Note: Adjust V_{test} for +3.2V DC at LM2408 input pins.

FIGURE 2. Test Circuit (One Channel)

Figure 2 shows a typical test circuit for evaluation of the LM2408. This circuit is designed to allow testing of the LM2408 in a 50Ω environment, such as a pulse generator,

oscilloscope or network analyzer. The 4950Ω resistor at the output forms a 100:1 voltage divider when connected to a 50Ω load.

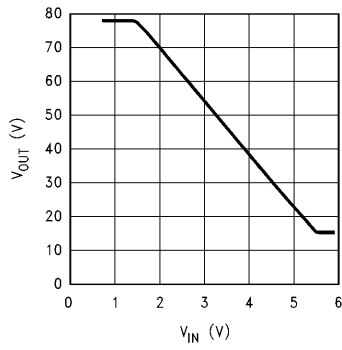

FIGURE 3. V_{OUT} vs V_{IN}

TL/H/12683-4

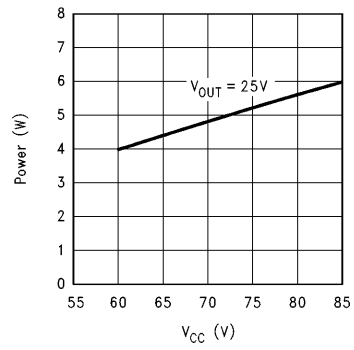

FIGURE 4. Power Dissipation vs V_{CC}

TL/H/12683-5

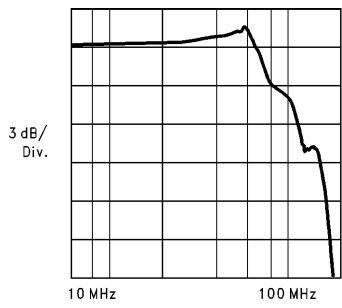

FIGURE 5. Large Signal Frequency Response

TL/H/12683-6

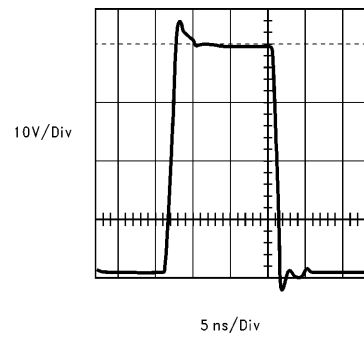

FIGURE 6. Pulse Response

TL/H/12683-7

Theory of Operation

The LM2408 is a high voltage monolithic triple CRT driver suitable for SVGA and XGA display applications. The LM2408 features +80V operation and low power dissipation. The part is housed in the industry standard 11-Lead TO-220 molded plastic power package.

The simplified circuit diagram of the LM2408 is shown in *Figure 1*. A PNP emitter follower, Q1, provides input buffering. Q2 and Q3 form a high gain amplifier. Feedback around this amplifier through the 15 k Ω resistor, working with the 1 k Ω input resistor, sets the gain to -15. Emitter followers Q5 and Q6 isolate the high output impedance of the amplifier from the capacitance of the CRT cathode, and make the circuit relative insensitive to load capacitance.

Figure 2 shows a typical test circuit for evaluation of the LM2408. This circuit is designed to allow testing of the LM2408 in a 50 Ω environment, such as a pulse generator and a scope, or a network analyzer. In this test circuit, two low inductance resistors in series totaling 4.95 k Ω form a 100:1 wideband low capacitance probe when connected to a 50 Ω cable and load. The input signal from the generator is AC coupled to the base of Q1.

Application Hints

INTRODUCTION

National Semiconductor is committed to providing application information that assists our customers in obtaining the best performance possible from our products. The following information is provided in order to support this commitment. The reader should be aware that the optimization of performance was done using specific printed circuit boards designed at National. Variations in performance can be realized due to physical changes in the printed circuit board and the application. Therefore, the designer should be aware that component value and board layout changes may be required to optimize performance in a given application. The values shown in this document can be used as a starting point for testing and evaluation purposes. When working with high bandwidth circuits, good layout practices are also critical to achieving maximum performance.

POWER SUPPLY BYPASS

Since the LM2408 is a wide bandwidth amplifier, proper power supply bypassing is critical for optimum performance. Improper power supply bypassing can result in large overshoot, ringing and oscillation. A 0.01 μ F capacitor should be connected from the supply pin, V_{CC} , to ground, as close to the supply pin as is practical (preferably less than 1/4" from the supply pin). Additionally, a 10 μ F to 100 μ F electrolytic capacitor should be connected from the supply pin to ground. The electrolytic capacitor should also be placed reasonably close to the LM2408's supply pin. A 0.1 μ F capacitor should be connected from the bias pin, V_{BB} , to ground, as close as is practical to the part.

ARC PROTECTION

During normal CRT operation, internal arcing may occasionally occur. Spark gaps of 200V to 300V at the cathodes will limit the maximum voltage, but to a value that is much high-

er than allowable on the LM2408. This fast, high voltage, high energy pulse can damage the LM2408 output stage. The addition of clamp diodes D1 and D2 (as shown in *Figure 7*) will help clamp the voltage at the output of the LM2408 to a safe level. The clamp diodes should have a fast transient response, high peak current rating, low series impedance and low shunt capacitance. FDH400 or equivalent diodes are recommended. Resistor R2 in *Figure 7* limits the arcover current while R1 limits the current into the LM2408 and reduces the power dissipation of the output transistors when the output is stressed beyond the supply voltage. Peaking inductor L_p also helps protect the LM2408 from CRT arcover, and is part of the arc protection circuit. Having large value resistors for R1 and R2 would be desirable, but this has the effect of increasing rise and fall times. For proper arc protection, it is important to not omit any of the arc protection components shown in *Figure 7*.

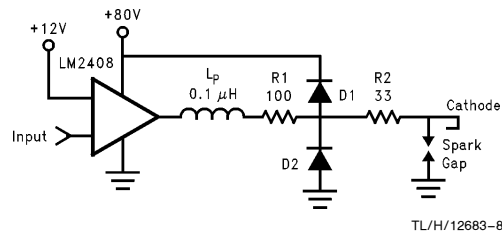

FIGURE 7. One Section of the LM2408 with Arc Protection and Peaking Inductor L_p

There are also ESD protection diodes built into the part. To avoid damaging these diodes, do not apply an input voltage from a low impedance source when the V_{BB} and V_{CC} pins are held at ground potential.

IMPROVING RISE AND FALL TIMES

Because of an emitter follower output stage, the rise and fall times of the LM2408 are relatively insensitive to capacitive loading. However, the series resistors R1 and R2 (see *Figure 7*) will increase the rise and fall times when driving the CRT's cathode which appears as a capacitive load. The capacitance at the cathode typically ranges from 8 pF to 12 pF.

To improve the rise and fall times at the cathode, a small inductor is often used in series with the output of the amplifier. The inductor L_p in *Figure 7* peaks the amplifier's frequency response at the cathode, thus improving rise and fall times. It also acts with the output load capacitance to form a low pass filter, which reduces the amplitudes of high frequency harmonics of the video signal, to lower radiated electromagnetic interference. The inductor value is empirically determined and is dependent on the load. An inductor value of 0.1 μ H is a good starting value. Note that excessive peaking of the amplifier's frequency response will increase the overshoot. Choosing the correct values for R1, R2 and L_p will provide arc protection and the fastest rise and fall times without excessive peaking.

EFFECT OF LOAD CAPACITANCE

The output rise and fall times will be slower than specified if the load capacitance at the output is more than 8 pF, as shown in *Figure 8*.

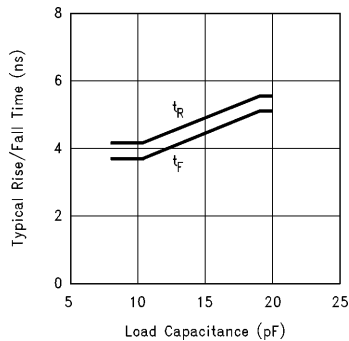

TL/H/12683-9

FIGURE 8. Effect of Load Capacitance on Rise/Fall Time

The monitor designer should ensure that stray capacitance applied to the LM2408 is as low as possible.

THERMAL CONSIDERATIONS

Power supply current increases as the input signal increases and consequently power dissipation also increases.

The LM2408 cannot be used without heat sinking. Typical "average" power dissipation with the device output voltage at one half the supply voltage is 1.9W per channel for a total dissipation of 5.7W package dissipation. The power dissipation does not vary much as output voltage varies. The LM2408 case temperature must be maintained below 100°C. If the maximum expected ambient temperature is 50°C, then a maximum heat sink thermal resistance can be calculated:

$$R_{th} = \frac{100^{\circ}\text{C} - 50^{\circ}\text{C}}{5.7\text{W}} = 8.8^{\circ}\text{C}/\text{W}.$$

This example assumes a typical CRT capacitive load and is without a resistive load. Note that this thermal resistance must be achieved when the heat sink is operating in the monitor.

PC BOARD LAYOUT CONSIDERATIONS

For optimum performance, an adequate ground plane, isolation between channels, good supply bypassing and minimizing unwanted feedback are necessary. Also, the length of the signal traces from the preamplifier to the LM2408 and from the LM2408 to the CRT cathode should be as short as possible. The following references are recommended:

Ott, Henry W., "Noise Reduction Techniques in Electronic Systems", John Wiley and Sons, New York, 1976.

"Guide to CRT Video Design", National Semiconductor Application Note 861.

"Video Amplifier Design for Computer Monitors", National Semiconductor Application Note 1013.

Because of its high small signal bandwidth, the part may oscillate when it is used in a typical application with a preamp in a monitor, if feedback occurs around the video amplifier through the chassis wiring. To prevent this, leads to the input circuit should be shielded, and input circuit wiring should be spaced as far as possible from output circuit wiring. Power should be removed as quickly as possible from an amplifier that is oscillating, since power dissipation in the part is very high in this mode and the part may be damaged if oscillations continue and the power supply can supply more than 250 mA.

Capacitive loading on the output will cause some overshoot and peaking. This can be controlled by placing a resistor in series with the output of the part. Because of differences in stray capacitance in different pc board layouts, the best value of resistance to use must be determined separately for each application. Typical values between 50Ω and 200Ω provide good performance, with the larger values resulting in less peaking and slower rise and fall times.

Driving the output voltage of the part outside of its linear range will cause distorted signal waveforms and recovery times that are very much longer than the specified rise and fall times. When the amplifier output voltage is being driven from positive saturation into the linear range, an overshoot of several volts for up to 50 ns may occur. In a typical monitor design, this may occur if blanking pulses are applied to the video signal. The output voltage range should be limited so this does not happen, and will be approximately no lower than 25V and no higher than $V_{CC} - 5V$.

TYPICAL APPLICATION

A typical application of the LM2408 is shown in *Figure 9*. Used in conjunction with an LM1205, a complete video channel from monitor input to CRT cathode can be achieved. Performance is satisfactory for all applications up to 1280 × 1024 non-interlaced, and pixel clock frequencies up to 160 MHz.

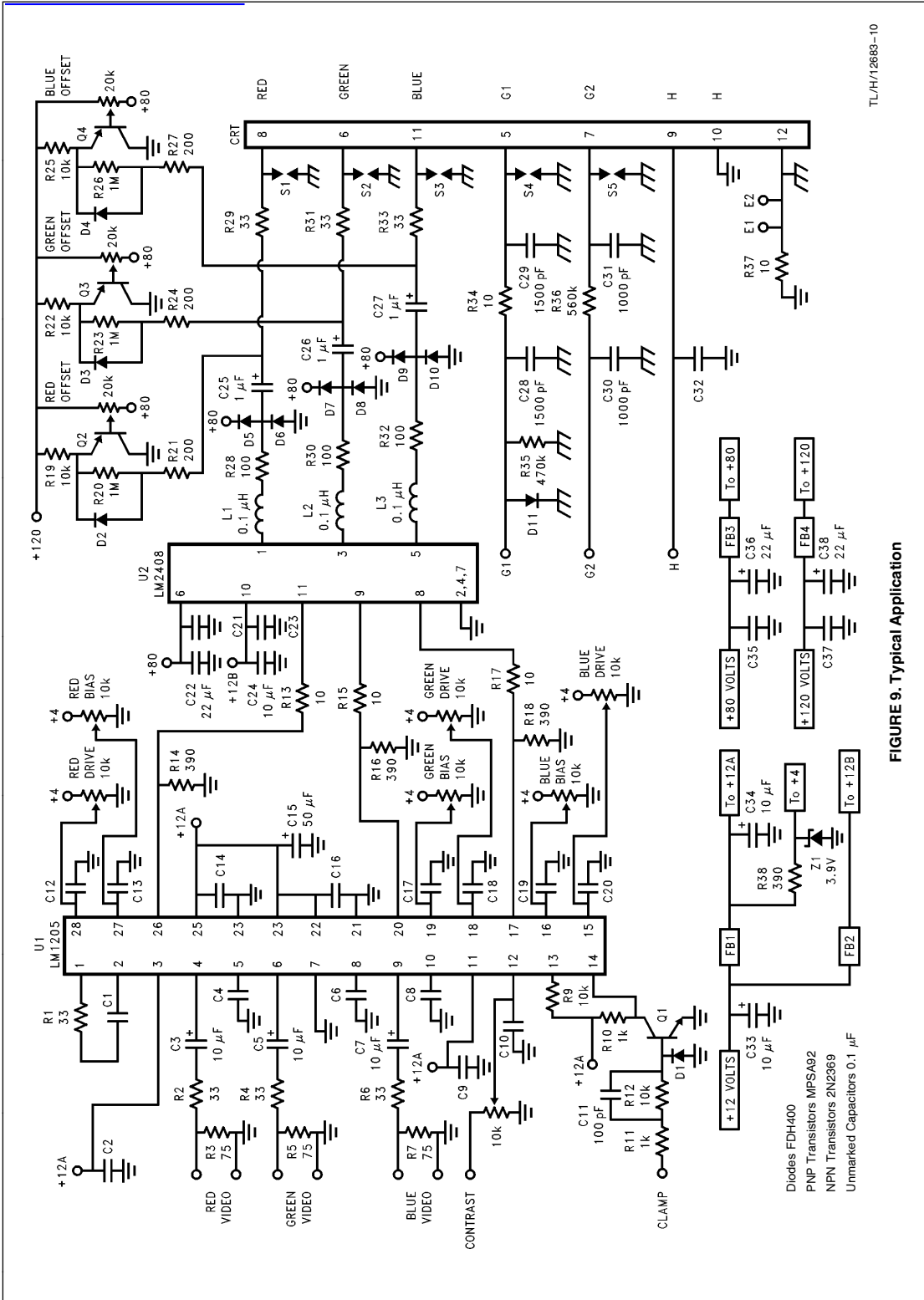

TL/H/12683-10

FIGURE 9. Typical Application

[查询"LM2408"供应商](#)

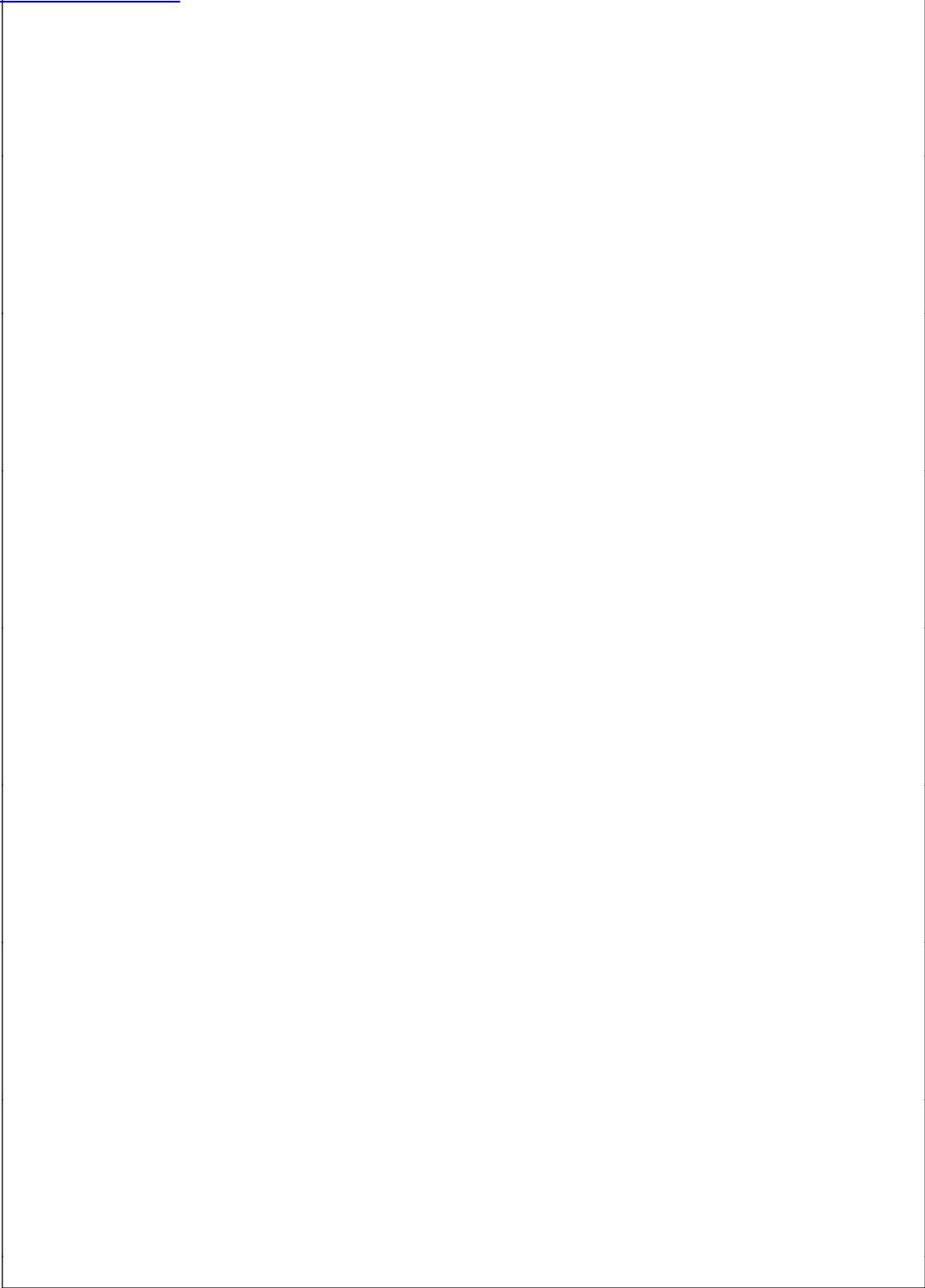

Physical Dimensions inches (millimeters) unless otherwise noted

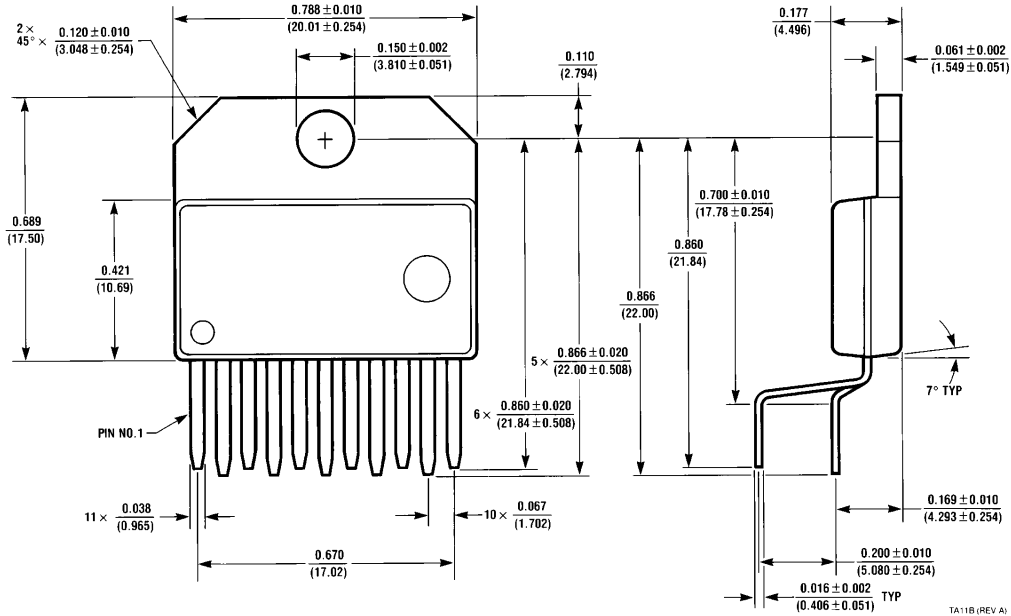

LM2408
11-Lead Molded TO-220
NS Package Number TA11B

LIFE SUPPORT POLICY

NATIONAL'S PRODUCTS ARE NOT AUTHORIZED FOR USE AS CRITICAL COMPONENTS IN LIFE SUPPORT DEVICES OR SYSTEMS WITHOUT THE EXPRESS WRITTEN APPROVAL OF THE PRESIDENT OF NATIONAL SEMICONDUCTOR CORPORATION. As used herein:

1. Life support devices or systems are devices or systems which, (a) are intended for surgical implant into the body, or (b) support or sustain life, and whose failure to perform, when properly used in accordance with instructions for use provided in the labeling, can be reasonably expected to result in a significant injury to the user.
2. A critical component is any component of a life support device or system whose failure to perform can be reasonably expected to cause the failure of the life support device or system, or to affect its safety or effectiveness.



National Semiconductor Corporation
Americas
 Tel: 1(800) 272-9959
 Fax: 1(800) 737-7018
 Email: support@nsc.com

National Semiconductor Europe
 Fax: +49 (0) 180-530 85 86
 Email: europe.support@nsc.com
 Deutsch Tel: +49 (0) 180-530 85 85
 English Tel: +49 (0) 180-532 78 32
 Français Tel: +49 (0) 180-532 93 58
 Italiano Tel: +49 (0) 180-534 16 80

National Semiconductor Southeast Asia
 Fax: (852) 2376 3901
 Email: sea.support@nsc.com

National Semiconductor Japan Ltd.
 Tel: 81-3-5620-7561
 Fax: 81-3-5620-6179

<http://www.national.com>