

DRAWING MADE IN THIRD ANGLE PROJECTION

THIS DRAWING IS UNPUBLISHED. RELEASED FOR PUBLICATION
 BY AMP INCORPORATED. ALL INTERNATIONAL RIGHTS RESERVED.

REVOLUTION		ZONE		LTR		DESCRIPTION	DATE	APPD
23	BD	35		B		REDRAWN	4/2/91	-
				C		REV PER ECN B06815	10/16/92	KB

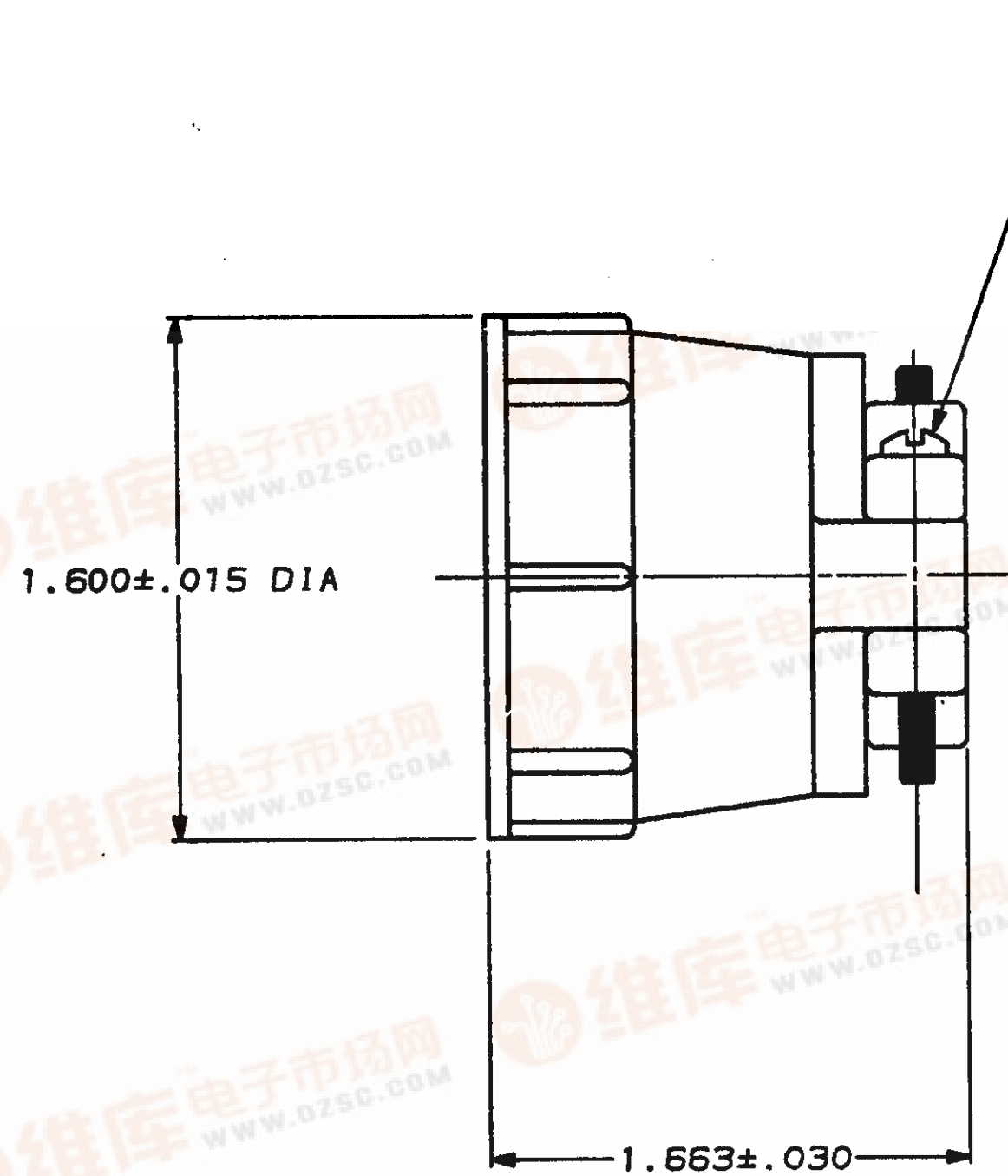

(2) #5-20 SELF-TAPPING SCREWS,
 SOLID OR SLOTTED SHANK.
 MATERIAL: ZINC PLATED STEEL
 LENGTH: 1.000

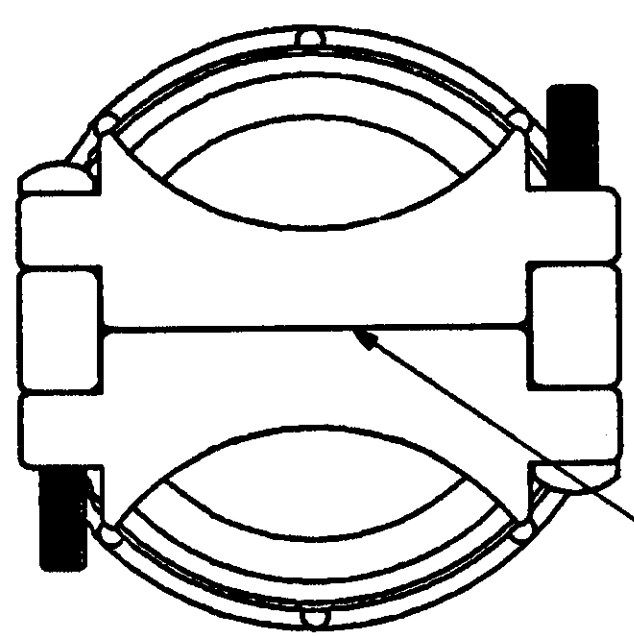

MINIMUM

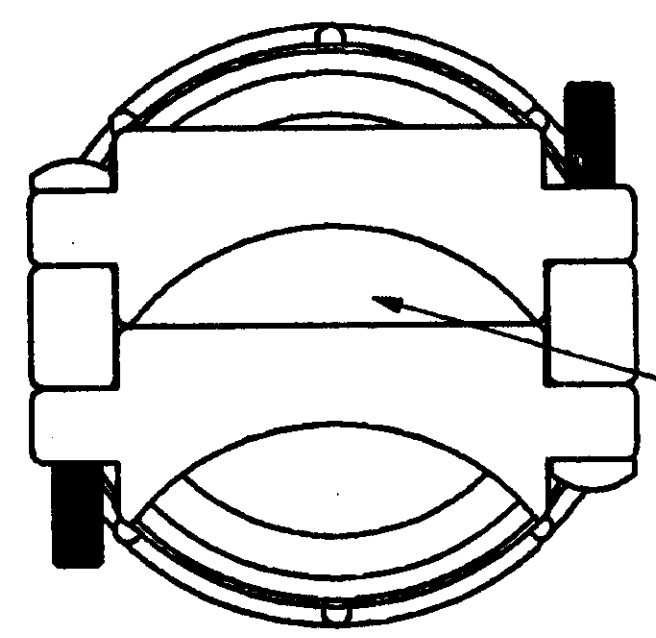

INTERMEDIATE

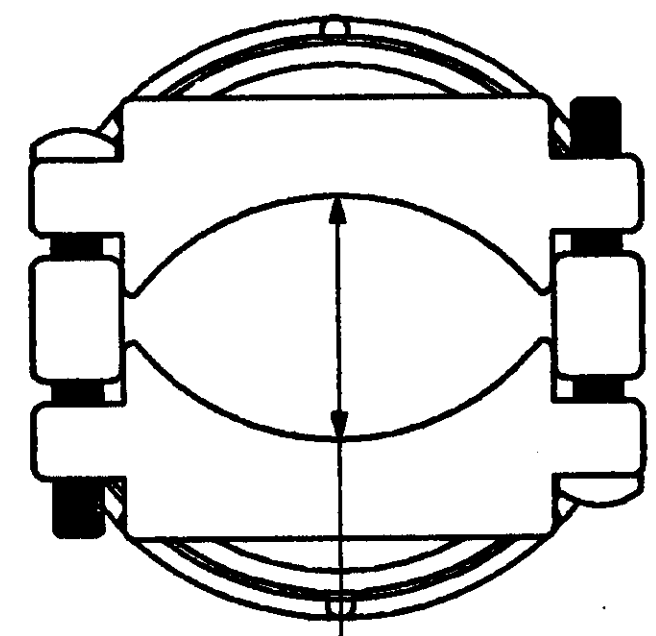

MAXIMUM

△ BULK	207774-2
INDIVIDUAL	207774-1
PACKAGING	PART NUMBER

- 1. PARTS PACKAGED UNASSEMBLED.
- △ 2 CABLE CLAMPING AREA ADJUSTABLE FROM .000 TO .652 SQ IN, MAX CABLE DIA = 1.125 INCHES. TWO CLAMPING INSERTS SUPPLIED WITH ASSEMBLY, CLAMPING SREA DETERMINED BY POSITION OF INSERTS AS SHOWN AT RIGHT.
- △ 3 BULK PACKAGED KITS TO BE ORDERED IN MULTIPLES OF 250 ONLY.

DO NOT SCALE PRINT. UNLESS SPECIFIED DIMENSIONS IN INCHES TOLERANCES ON: 2 PLC DEC ± - 3 PLC DEC ± - ANGLES ± -	DR 4-3-91 I. STAUB BG	AMP Incorporated Harrisburg, PA 17105-3608
	CHK 7-23-92 W.G. LENKER	
MATERIAL THERMOPLASTIC, BLACK	APPD 7-23-92 K. BEAVER	NAME CABLE CLAMP KIT, SELF CENTERING, SHELL SIZE 23, CPC
FINISH	APPD 7-23-92 C. RÖHDE	SIZE C 00779
WEIGHT	PRODUCT SPEC 108-10024	SCALE 2:1
	APPLICATION SPEC	DRAWING NO. 207774
		SHEET 1 OF 1

CUSTOMER DRAWING