

SPECIFICATION

DEVICE NAME : Power MOSFET

TYPE NAME : 2SK2827-01

SPEC. NO. :

Fuji Electric Co.,Ltd.

This Specification is subject to change without notice.

	DATE	NAME	APPROVED	Fuji Electric Co.,Ltd.	
DRAWN				DWG. NO.	1/12
CHECKED					

- 1.Scope This specifies Fuji Power MOSFET 2SK2827-01
- 2.Construction N-Channel enhancement mode power MOSFET
- 3.Applications for Switching
- 4.Outview TO-220 Outview See to 5/12 page

5.Absolute Maximum Ratings at Tc=25°C (unless otherwise specified)

Description	Symbol	Characteristics	Unit	Remarks
Drain-Source Voltage	V_{DS}	600	V	
Continuous Drain Current	I_D	± 9	A	
Pulsed Drain Current	I_{DP}	± 32	A	
Gate-Source Voltage	V_{GS}	± 35	V	
Repetitive or non-repetitive	I_{AV}	9	A	$T_{ch} \leq 150^\circ C$
Maximum Avalanche Energy	E_{AV}	144.4	mJ	*1
Maximum Power Dissipation	P_D	60	W	
Operating and Storage	T_{ch}	150	°C	
Temperature range	T_{stg}	-55 to +150	°C	

*1 L=3.27mH, Vcc=60V

6.Electrical Characteristics at Tc=25°C (unless otherwise specified)

Static Ratings

Description	Symbol	Conditions	min.	typ.	max.	Unit
Drain-Source Breakdown Voltage	BV_{DSS}	$I_D=1mA$ $V_{GS}=0V$	600			V
Gate Threshold Voltage	$V_{GS(th)}$	$I_D=1mA$ $V_{DS}=V_{GS}$	3.5	4.0	4.5	V
Zero Gate Voltage Drain Current	I_{DSS}	$V_{DS}=600V$ $V_{GS}=0V$ $T_{ch}=25^\circ C$		10	500	μA
		$T_{ch}=125^\circ C$		0.2	1.0	mA
Gate-Source Leakage Current	I_{GSS}	$V_{GS}=\pm 35V$ $V_{DS}=0V$		10	100	nA
Drain-Source On-State Resistance	$R_{DS(on)}$	$I_D=4.5A$ $V_{GS}=10V$		1.0	1.2	Ω

Dynamic Ratings

Description	Symbol	Conditions	min.	typ.	max.	Unit
Forward Transconductance	g_{fs}	$I_b=4.5A$ $V_{DS}=25V$	2.5	5.0		S
Input Capacitance	C_{iss}	$V_{DS}=25V$		900	1400	pF
Output Capacitance	C_{oss}	$V_{GS}=0V$		150	230	
Reverse Transfer Capacitance	C_{rss}	$f=1MHz$		70	110	
Turn-On Time	$t_d(on)$	$V_{cc}=300V$		25	40	ns
	t_r	$V_{GS}=10V$		70	110	
Turn-Off Time	$t_d(off)$	$I_b=9A$		60	90	
	t_f	$R_{GS}=10\Omega$		35	60	

Reverse Diode

Description	Symbol	Conditions	min.	typ.	max.	Unit
Avalanche Capability	I_{AV}	$L=3.27mH$ $T_{ch}=25^\circ C$ See Fig.1 and Fig.2	9			A
Diode Forward On-Voltage	V_{SD}	$I_F=2 \times I_{DR}$ $V_{GS}=0V$ $T_{ch}=25^\circ C$		1.0	1.5	V
Reverse Recovery Time	t_{rr}	$I_F=2 \times I_{DR}$		550		ns
Reverse Recovery Charge	Q_{rr}	$-di/dt=100A/\mu s$ $T_{ch}=25^\circ C$		7		μc

7. Thermal Resistance

Description	Symbol	min.	typ.	max.	Unit
Channel to Case	$R_{th}(ch-c)$			2.08	$^\circ C/W$
Channel to Ambient	$R_{th}(ch-a)$			75.0	$^\circ C/W$

Fig.1 Test Circuit

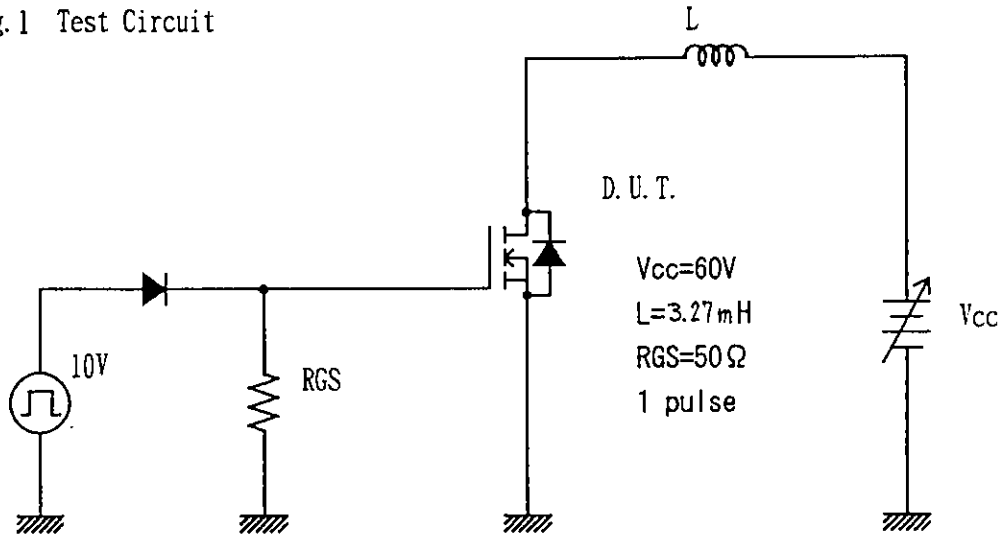
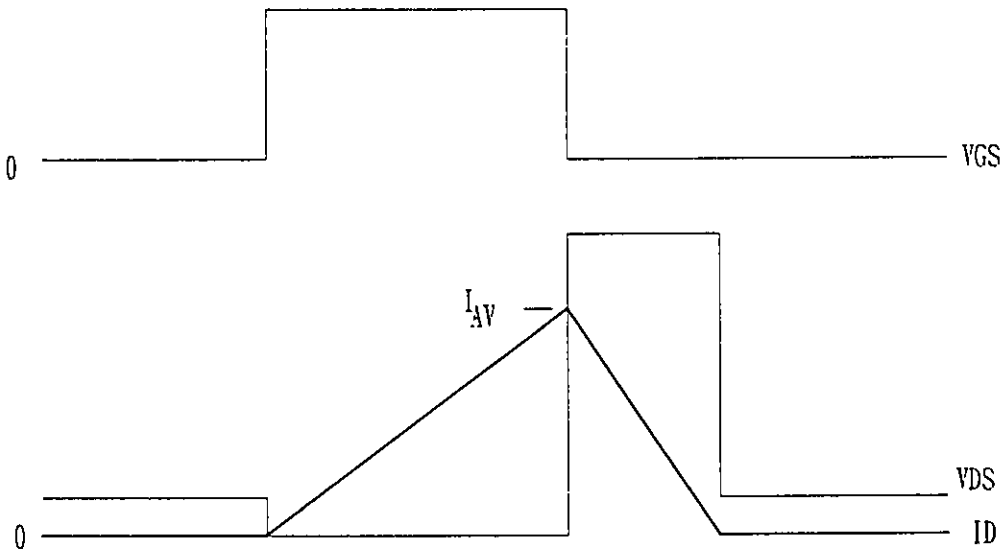
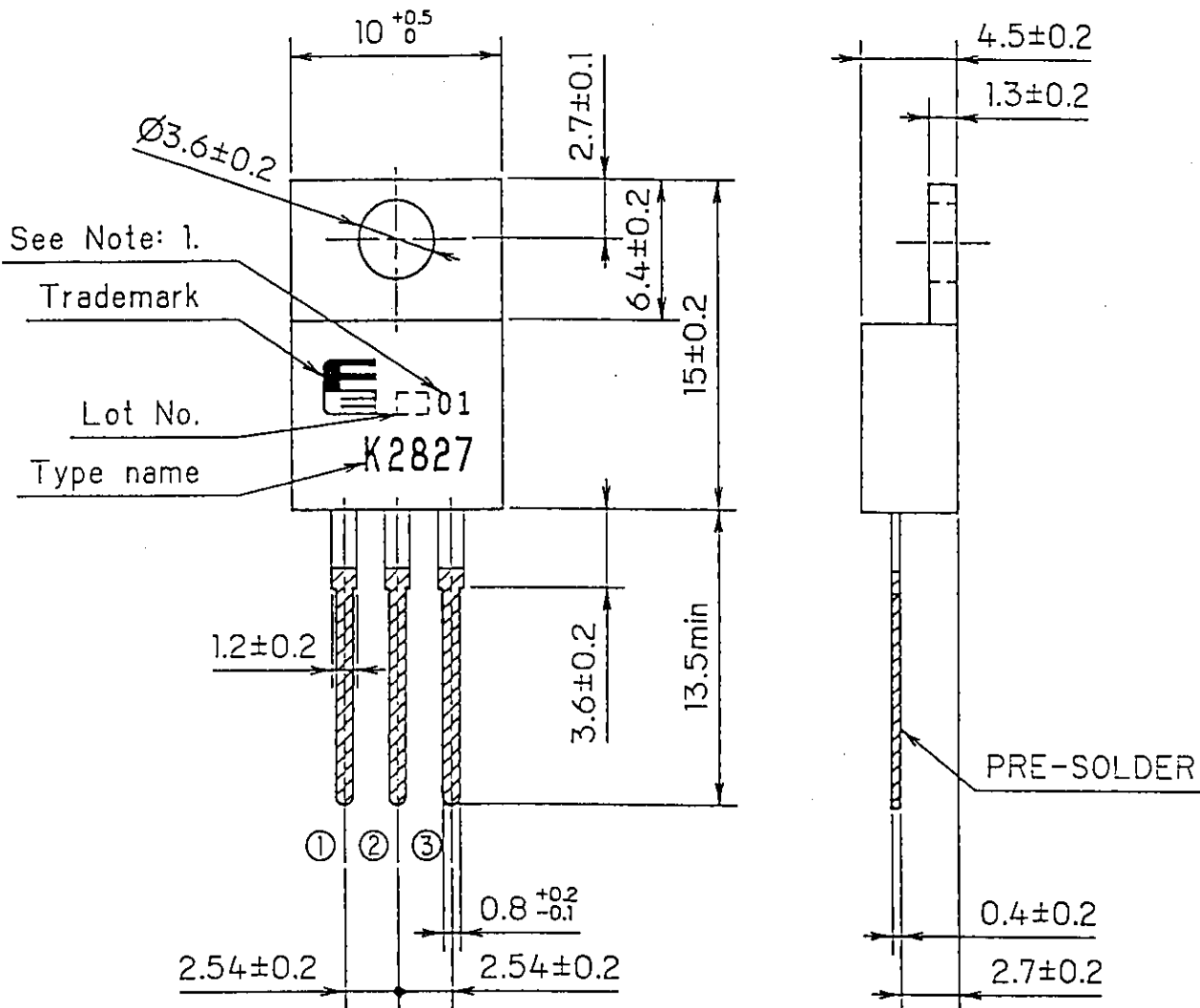

Fig.2 Operating waveforms



FUJI POWER MOS FET

TYPE : 2SK2827-01



CONNECTION

- ① GATE
- ② DRAIN
- ③ SOURCE

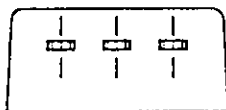

① ② ③

JEDEC : TO-220AB

Note: 1. Guaranteed mark of avalanche ruggedness.

DIMENSIONS ARE IN MILLIMETERS.

Power Dissipation
 $PD=f(T_c)$

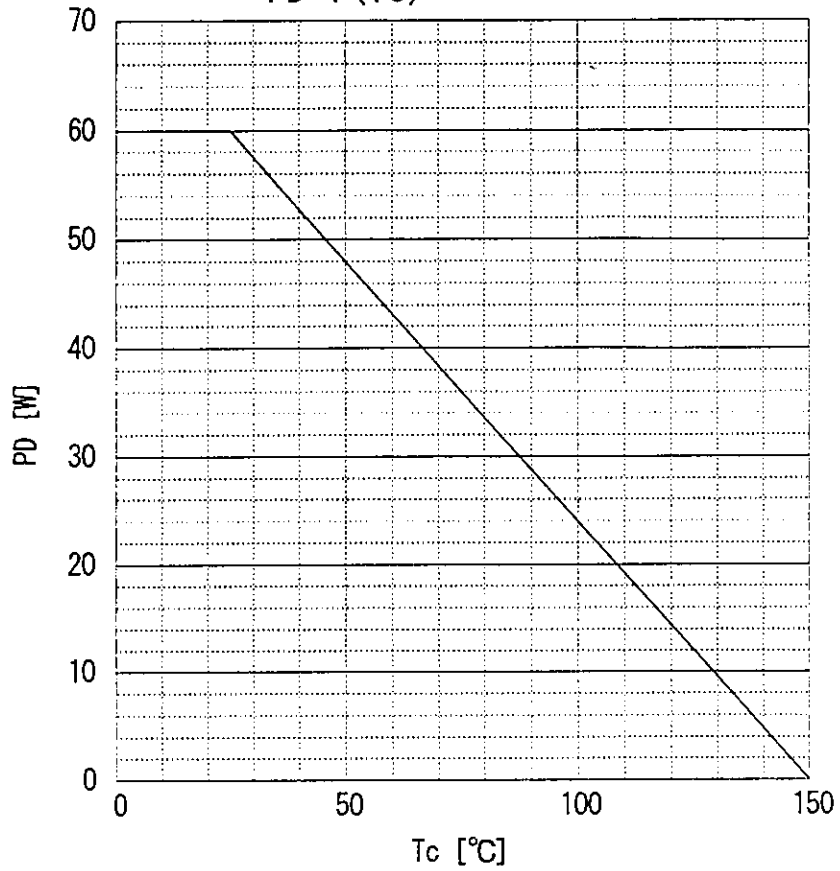

Safe operating area
 $ID=f(V_{DS}) : D=0.01, T_c=25^\circ C$

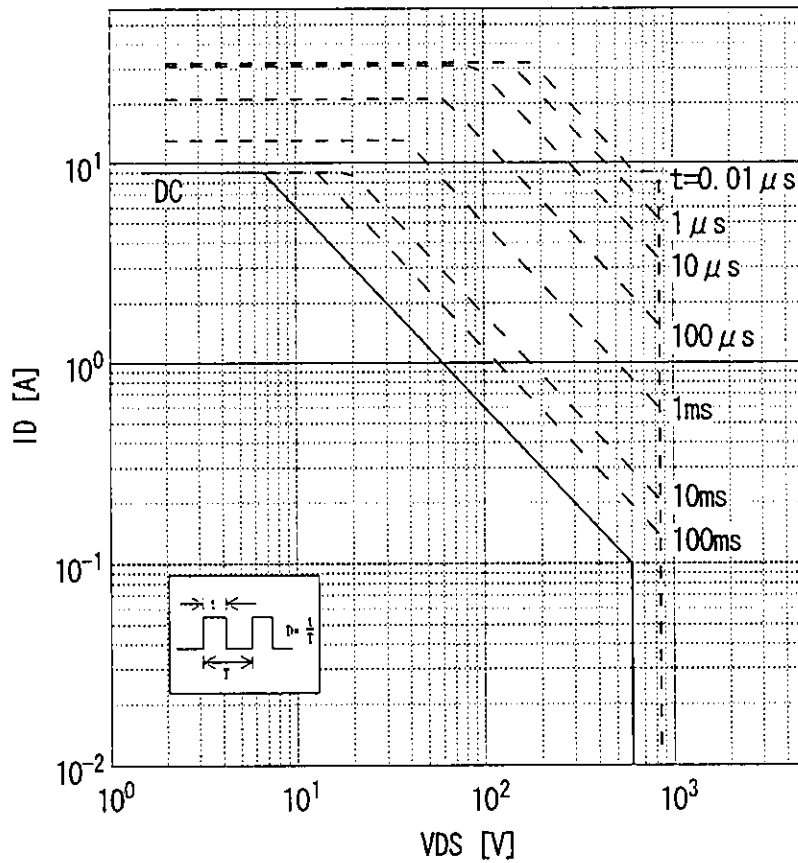

Typical output characteristics $I_D=f(V_{DS}) : 80\mu s$ pulse test, $T_c=25^\circ C$

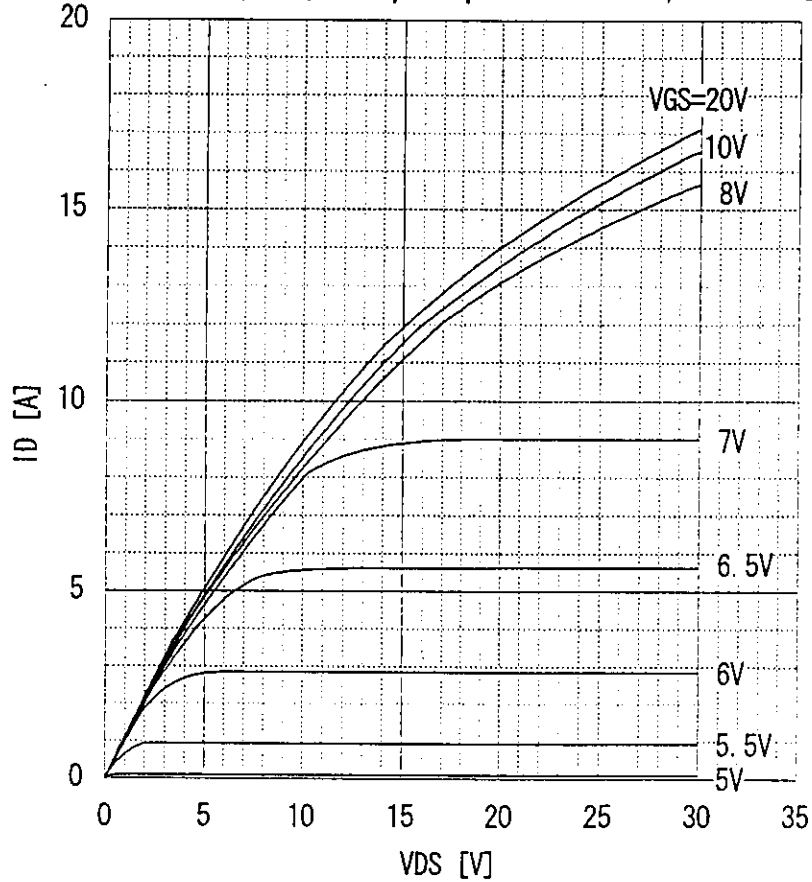

Typical transfer characteristic $I_D=f(V_{GS}) : 80\mu s$ pulse test, $V_{DS}=25V$, $T_{ch}=25^\circ C$

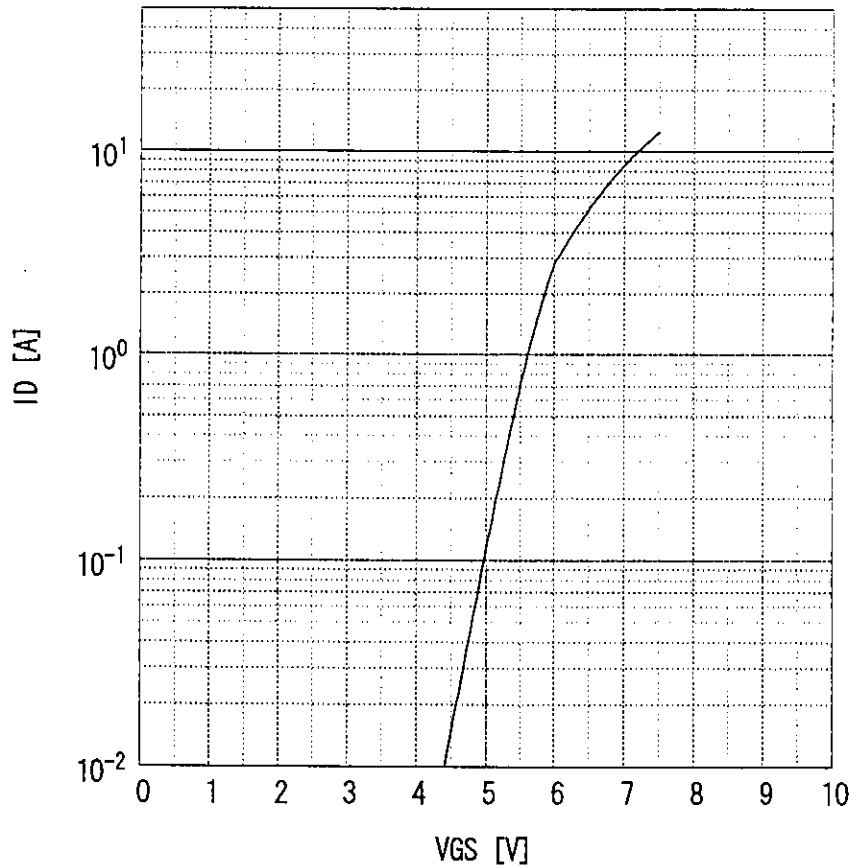

Typical forward transconductance
 $g_{fs}=f(I_D)$: 80 μ s pulse test, $V_{DS}=25V$, $T_{ch}=25^\circ C$

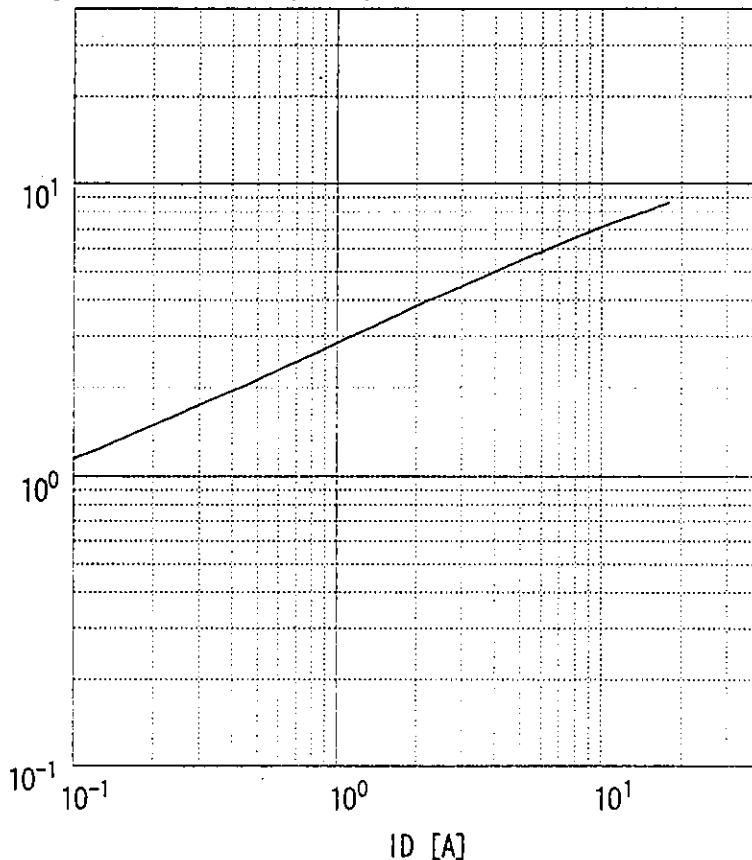

Typical drain-source on-state resistance
 $R_{DS(on)}=f(I_D)$: 80 μ s pulse test, $T_c=25^\circ C$

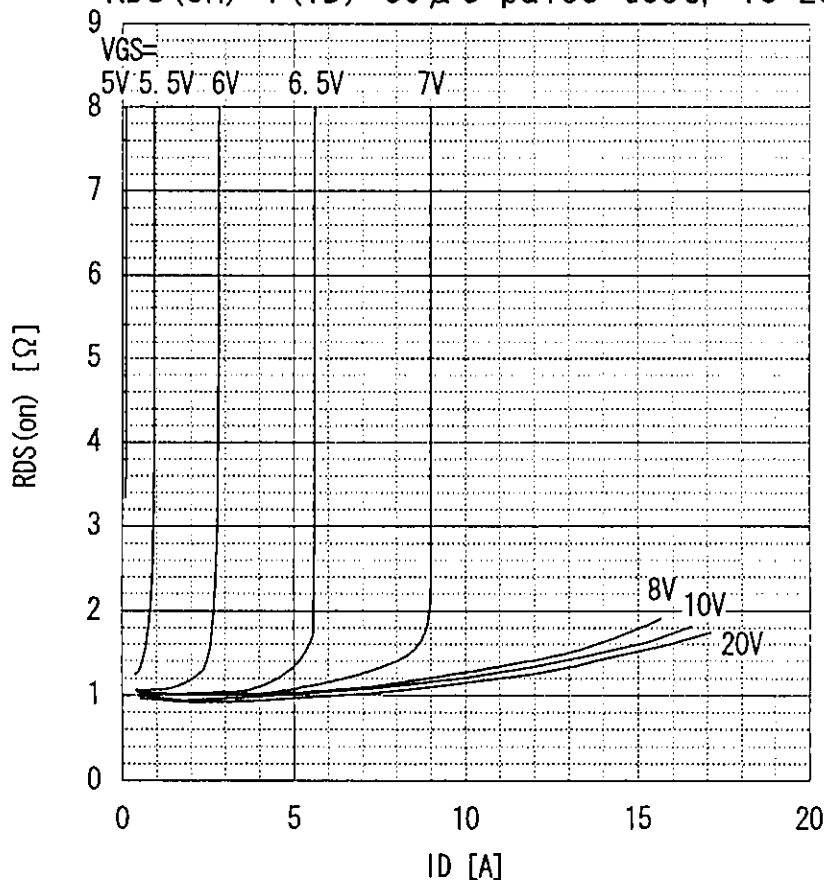

Drain-source on-state resistance
 $R_{DS(on)} = f(T_{ch}) : I_D = 4.5A, V_{GS} = 10V$

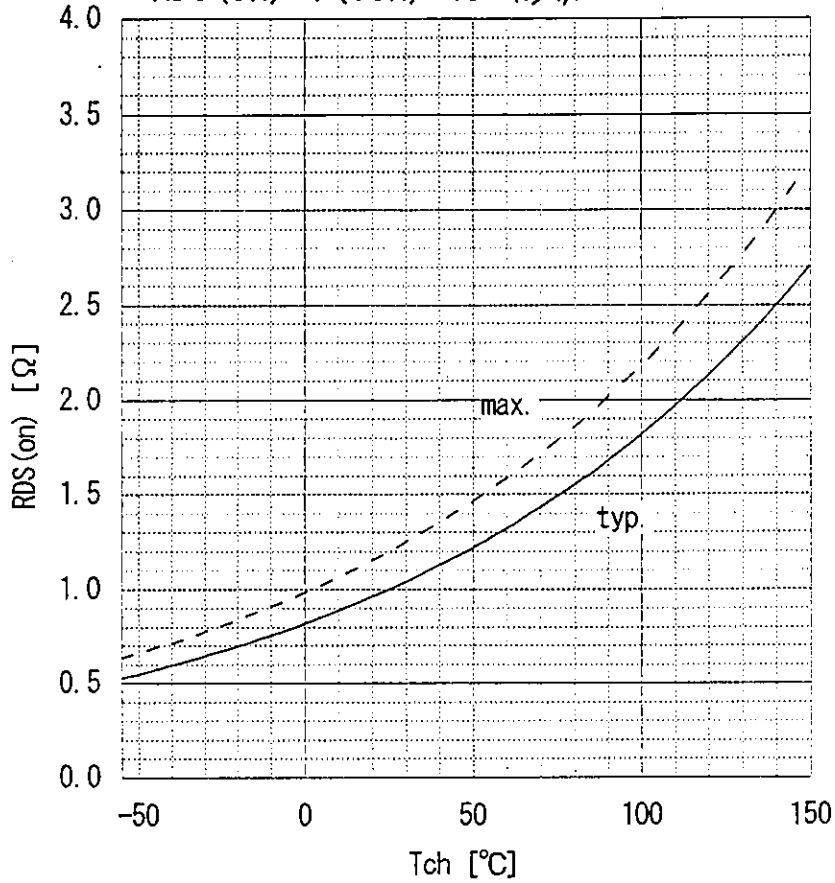

Gate threshold voltage
 $V_{GS(th)} = f(T_{ch}) : I_D = 1mA, V_{DS} = V_{GS}$

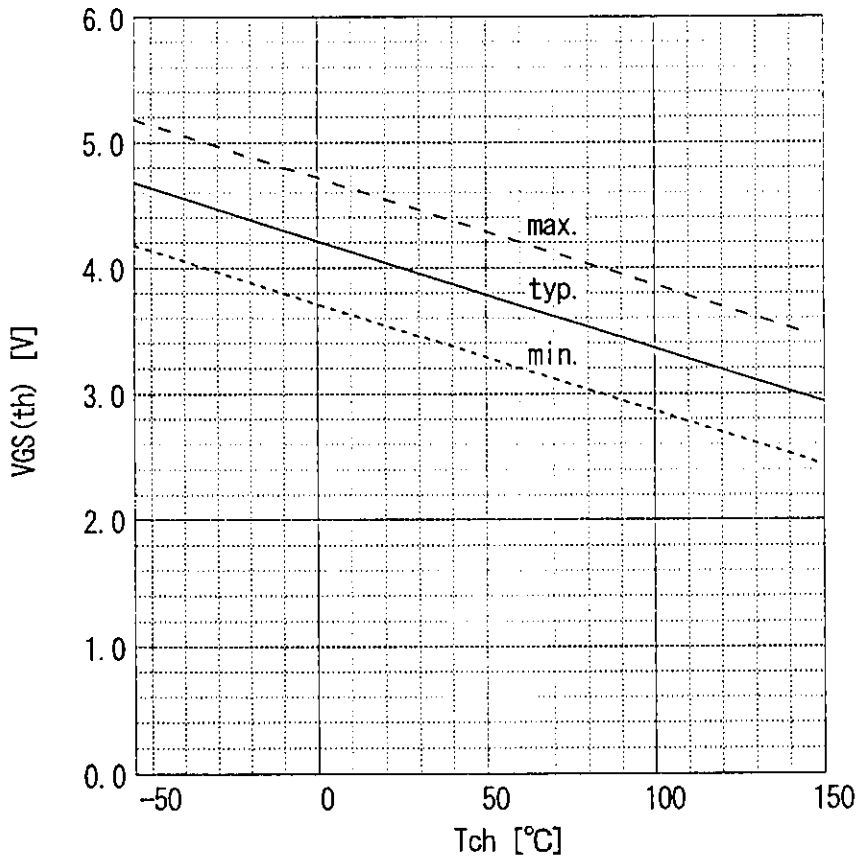

Typical gate charge characteristic $V_{GS} = f(Q_g) : I_D = 9A, T_c = 25^\circ C$

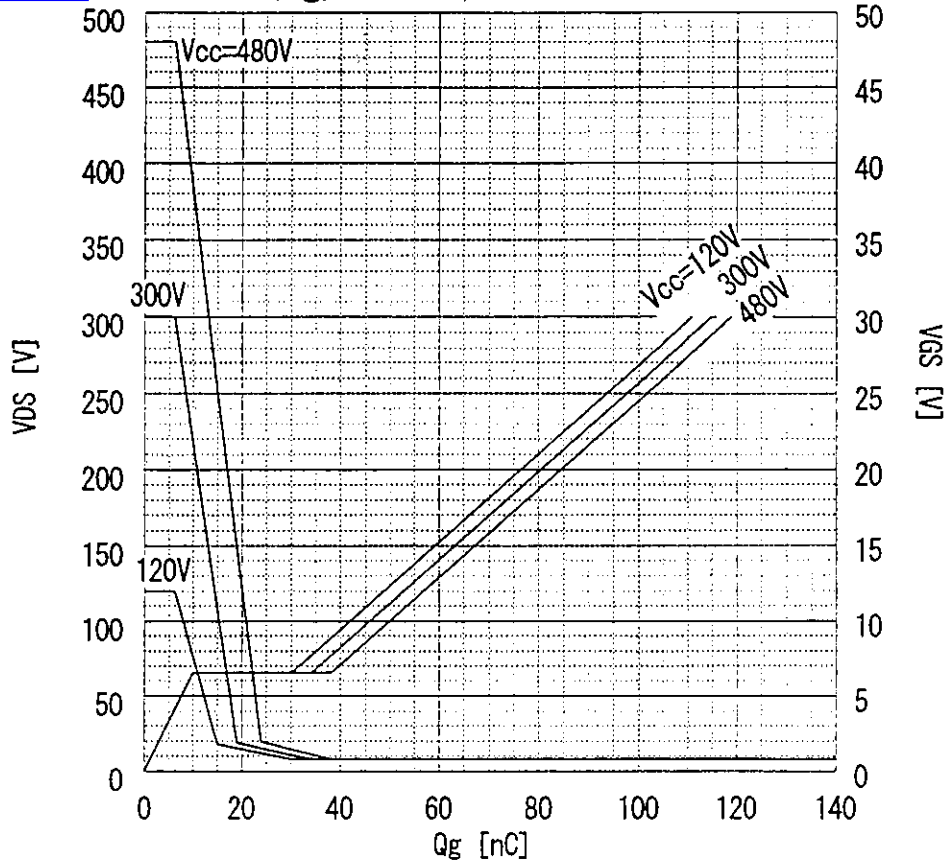

Typical capacitances $C = f(V_{DS}) : V_{GS} = 0V, f = 1MHz$

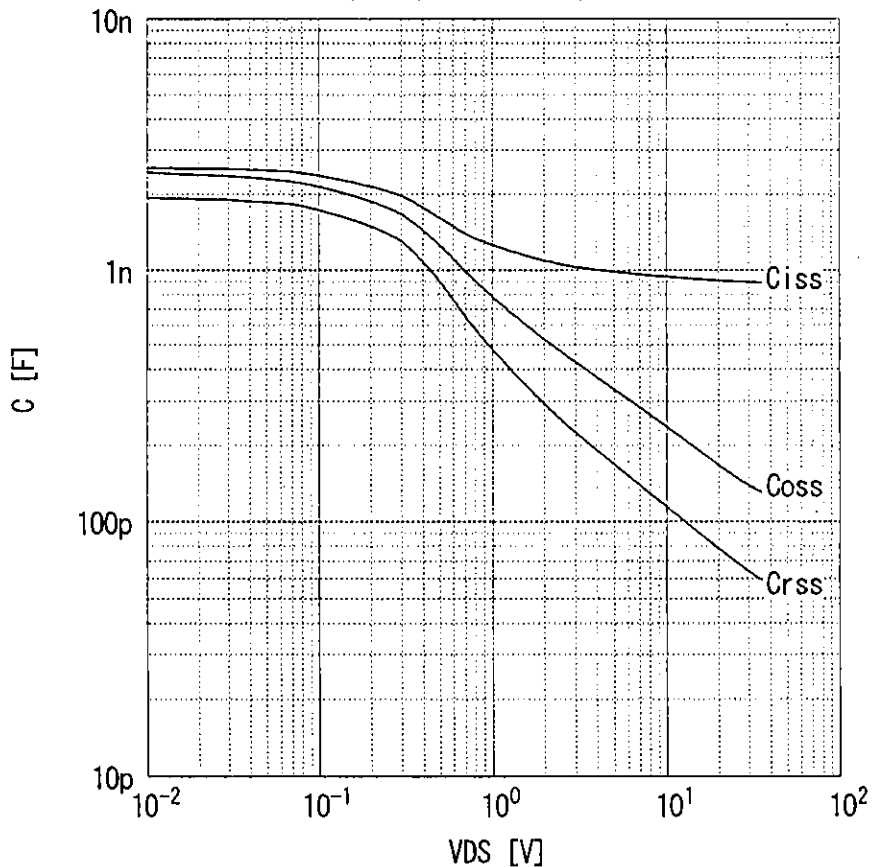

Forward characteristic of reverse of diode $I_F=f(V_{SD}) : 80 \mu s$ pulses test, $V_{GS}=0V$

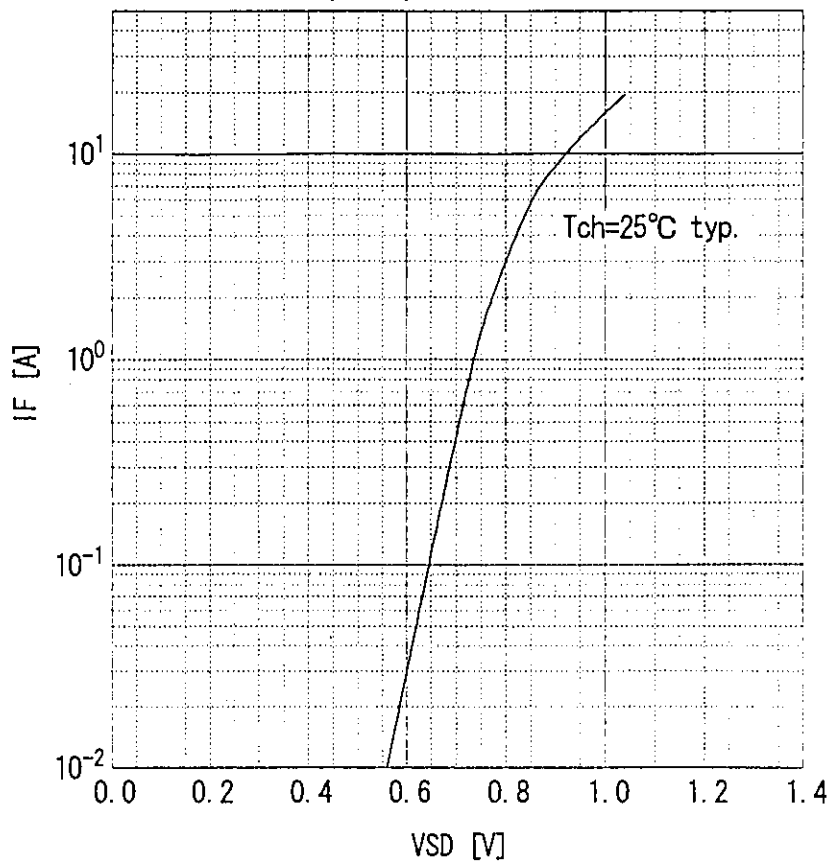

Transient thermal impedance $Z_{thch}=f(t)$ parameter: $D=t/T$

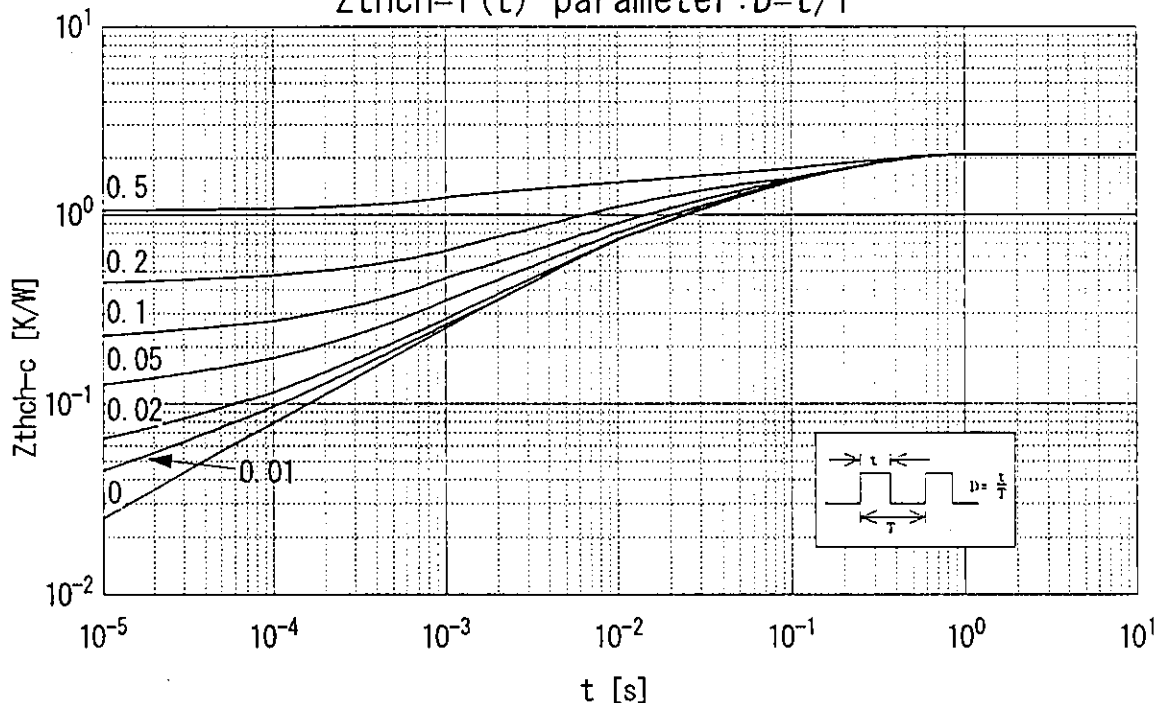

Avalanche energy derating

$E_{as}=f(\text{starting } T_{ch}) : V_{CC}=60V, I_{AV}=9A$

