

AME8831

■ General Description

The AME8831 family of positive, linear regulators feature low quiescent current (17 μ A typ.) with low dropout voltage, making them ideal for battery applications. The space-saving SOT-25 package is attractive for "Pocket" and "Hand Held" applications.

These rugged devices have both Thermal Shutdown, and Current limitation to prevent device failure under the "Worst" of operating conditions. In applications requires a low noise regulated supply. The AME8831 family uses the SR pin to program the output voltage's slew rate to control the in-rush current. This is specifically used in the USB application where large load capacitance is present at start-up.

The AME8831 also features a logic-enabled sleep mode to shutdown the regulator, reducing quiescent current to 1 μ A typical at $T_A = 25^\circ\text{C}$.

The AME8831 is stable with an output capacitance of 4.7 μ F or larger.

■ Features

- Guaranteed 150mA Output
- Dropout Voltage Typically 150 mV at 150 mA
- 17 μ A Quiescent Current
- Over-Temperature Shutdown
- Over-Current Limitation
- Noise Reduction Bypass Capacitor
- Power-Saving Shutdown Mode
- Space-Saving SOT-25 Package
- Factory Pre-set Output Voltages
- Enable pin option
 - $\overline{\text{EN}}$ active low enable
 - EN active high enable
- All AME's Lead Free Products Meet RoHS Standards

■ Applications

- Instrumentation
- Portable Electronics
- Wireless Devices
- Cordless Phones
- PC Peripherals
- Battery Powered Widgets
- Electronic Scales

■ Function Block Diagram

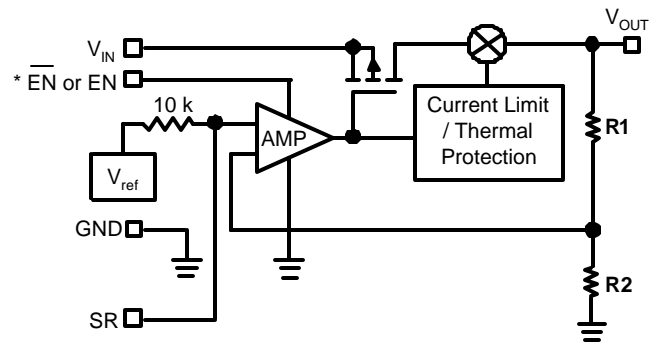

* AME8831A: $\overline{\text{EN}}$, AME8831B: EN

■ Typical Application

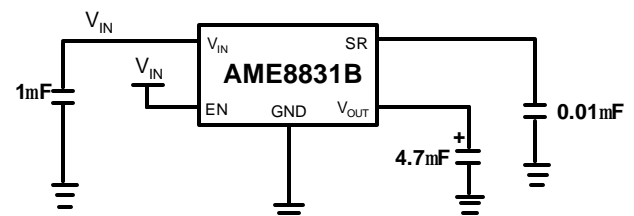
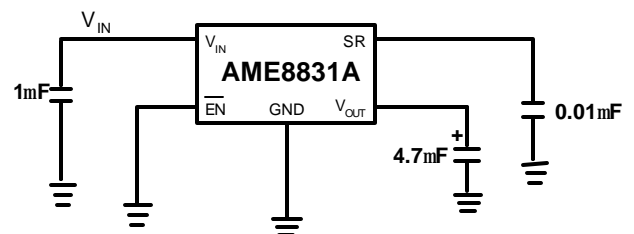

AME8831

■ **Pin Configuration**

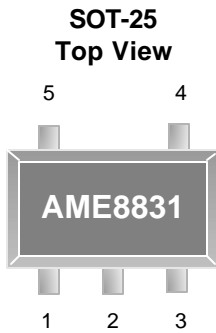

AME8831A

1. V_{IN}
2. GND
3. \overline{EN}
4. SR
5. V_{OUT}

* **Die Attach:**
Conductive Epoxy

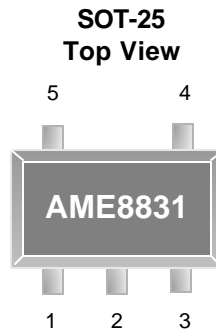

AME8831B

1. V_{IN}
2. GND
3. EN
4. SR
5. V_{OUT}

* **Die Attach:**
Conductive Epoxy

■ **Pin Description**

Pin Number	Pin Name	Pin Description
1	V_{IN}	The V_{IN} terminal is the input to the device.
2	GND	Regulator ground.
3	\overline{EN} , EN	\overline{EN} active low enable, EN active high enable.
4	SR	The SR terminal is used to control the in-rush current.
5	V_{OUT}	The V_{OUT} terminal is the regulated output of the device.

AME8831

Ordering Information

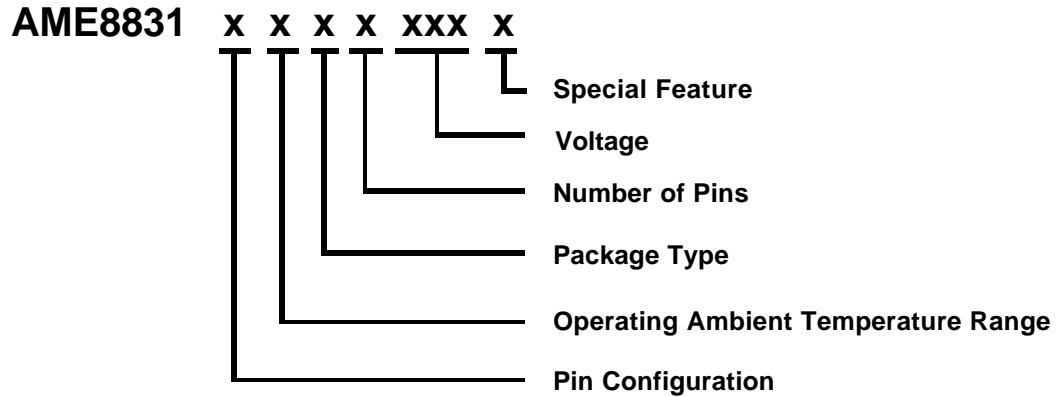

Pin Configuration	Operating Ambient Temperature Range	Package Type	Number of Pins	Voltage	Special Feature
A: 1. V _{IN} 2. GND 3. EN 4. SR 5. V _{OUT} B: 1. V _{IN} 2. GND 3. EN 4. SR 5. V _{OUT}	E: -40°C to +85°C	E: SOT-2X	V: 5	330: V=3.3V	Y: Lead free & Low profile Z: Lead free

Ordering Information

Part Number	Marking*	Output Voltage	Package	Operating Ambient Temperature Range
AME8831AEEV330Z	BDVww	3.3V	SOT-25	- 40°C to + 85°C
AME8831AEEV330Y	BDVww	3.3V	TSOT-25	- 40°C to + 85°C

Note: ww represents the date code and pls refer to the Date Code Rule before Package Dimension.

* A line on top of the first character represents lead free plating such as BDVww.

Please consult AME sales office or authorized Rep./Distributor for output voltage and package type availability.

AME8831

■ Absolute Maximum Ratings

Parameter	Maximum	Unit
Input Voltage	6	V
Output Current	$P_D / (V_{IN} - V_{OUT})$	mA
Output Voltage	GND-0.3 to $V_{IN}+0.3$	V
ESD Classification	C*	

Caution: Stress above the listed absolute maximum rating may cause permanent damage to the device
HBM C: 4000V+

■ Recommended Operating Conditions

Parameter	Symbol	Rating	Unit
Ambient Temperature Range	T_A	- 40 to +85	°C
Junction Temperature Range	T_J	- 40 to +125	
Storage Temperature Range	T_{STG}	-65 to +150	

■ Thermal Information

Parameter	Package	Die Attach	Symbol	Maximum	Unit
Thermal Resistance* (Junction to Case)	SOT-25	Conductive Epoxy	θ_{JC}	81	°C / W
Thermal Resistance (Junction to Ambient)			θ_{JA}	260	
Internal Power Dissipation			P_D	400	mW
Maximum Junction Temperature				150	°C
Solder Iron (10 Sec)**				350	°C

* Measure θ_{JC} on center of molding compound if IC has no tab.

** MIL-STD-202G 210F

AME8831

■ Electrical Specifications (contd.)

$\overline{EN}=0$, $T_J = -40$ to $+125^\circ\text{C}$, $V_{IN} = V_{OUT}(\text{typ}) + 1\text{V}$, $I_{OUT} = 1\text{mA}$, $C_{OUT} = 4.7\mu\text{F}$, $C_{(SR)} = 0.01\mu\text{F}$ (unless otherwise noted)

Parameter	Symbol	Test Condition	Min	Typ	Max	Units
Input Voltage	V_{IN}	(See Note1)	3.5		5.5	V
Output Voltage	V_{OUT}	$T_J = 25^\circ\text{C}$		3.3		V
		$10\mu\text{A} < I_{OUT} < 150\text{mA}$ $3.8\text{V} < V_{IN} < 5.5\text{V}$ $T_J = -40^\circ\text{C}$ to $+125^\circ\text{C}$	3.201		3.399	
Output Current	I_{OUT}	(See Note2)	0		150	mA
Output Current Limit	I_{LIM}	$V_{OUT} = 0\text{V}$	200	350	750	mA
Quiescent Current	I_Q	$10\mu\text{A} < I_{OUT} < 150\text{mA}$ $T_J = 25^\circ\text{C}$		17		μA
		$10\mu\text{A} < I_{OUT} < 150\text{mA}$ $T_J = -40^\circ\text{C}$ to $+125^\circ\text{C}$			30	
Line Regulation (See Note 3)	REG_{LINE}	$4.3\text{V} < V_{IN} < 5.5\text{V}$ $T_J = 25^\circ\text{C}$	-0.2	0.1	0.2	%V
		$4.3\text{V} < V_{IN} < 5.5\text{V}$ $T_J = -40^\circ\text{C}$ to $+125^\circ\text{C}$	-0.3		0.3	
Load Regulation (See Note 4)	REG_{LOAD}	$1\text{mA} \leq I_{OUT} \leq 150\text{mA}$ $T_J = 25^\circ\text{C}$	-0.02	0.0025	0.02	%/mA
Dropout Voltage	V_{DO}	$V_{OUT} = V_{OUT}(\text{NOM}) - 2.0\%$ $T_J = 25^\circ\text{C}$		150		mV
		$T_J = -40^\circ\text{C}$ to $+125^\circ\text{C}$			300	
Over Temperature Shutdown	OTS			150		$^\circ\text{C}$
Over Temperature Hysteresis	OTH			20		
V_{OUT} Temperature Coefficient	TC			30		ppm
Power Supply Ripple Rejection	PSRR	$f = 1\text{kHz}$, $I_{OUT} = 150\text{mA}$ $C_{OUT} = 10\mu\text{F}$, $C_{(SR)} = 0.01\mu\text{F}$ $T_J = 25^\circ\text{C}$		65		dB

Note1 : $V_{IN(\text{min})} = V_{OUT(\text{min})} + V_{DO(\text{maxload})}$

Note2 : Continuous output current and operating junction temperature are limited by internal protection circuitry, but it is not recommended that the device operate under conditions beyond those specified in this table for extended periods of time.

Note3: Line Reg:
$$\frac{\Delta V_{out}}{\Delta V_{in}} \times 100\%$$

Note4: Load Reg:
$$\frac{\Delta V_{out}}{V_{out}} \times 100\%$$

ΔI

**150mA Hi-PSRR, Low-Quiescent LDO
with In-Rush Current Control
For USB Application**

AME8831

■ Electrical Specifications

Parameter	Symbol	Test Condition		Min	Typ	Max	Units
Output Voltage Noise	e_N	BW=200Hz to 100kHz $I_{OUT} = 150mA$ $C_{OUT} = 10\mu F$ $C_{(SR)} = 0.47\mu F$	$T_J = 25^\circ C$		100		$\mu VRMS$
EN, \overline{EN} Input Threshold	V_{EH}	$V_{IN} = 3.5V$ to $5.5V$		2.0		V_{IN}	V
	V_{EL}			0		0.4	
EN, \overline{EN} Input Bias Current	$I_{EN}, I_{\overline{EN}}$	$EN = V_{IN}, \overline{EN} = 0, V_{IN} = 3.5V$ to $5.5V$				1	μA
Shutdown Current	I_{SD}	$EN = 0, \overline{EN} = V_{IN}$			1	2	μA
Turn_on Time	t_{ON}	$R_{LOAD} = 22\Omega$ $C_{OUT} = 10\mu F$	$C_{(SR)} = 0.01\mu F$	$T_J = 25^\circ C$		20	ms
			$C_{(SR)} = 0.1\mu F$			200	
			$C_{(SR)} = 0.22\mu F$			450	

AME8831

■ Detail Description

The AME8831 family of CMOS regulators contain a PMOS pass transistor, voltage reference, error amplifier, over-current protection, and thermal shutdown function.

The P-channel pass transistor receives data from the error amplifier, over-current limit, and thermal protection circuits. During normal operation, the error amplifier compares the output voltage to a precision reference. Over-current and Thermal shutdown circuits become active when the junction temperature exceeds 150°C, or the current exceeds about 350mA. During thermal shutdown, the output voltage remains low. Normal operation is restored when the junction temperature drops below 120°C.

The AME8831 switches from voltage mode to current mode when the load exceeds the rated output current. This prevents over-stress.

■ External Capacitors

The AME8831 is stable with an output capacitor to ground of 2.2 μ F or greater. Ceramic capacitors have the lowest ESR, and will offer the best AC performance. Conversely, Aluminum Electrolytic capacitors exhibit the highest ESR, resulting in the poorest AC response. Unfortunately, large value ceramic capacitors are comparatively expensive. One option is to parallel a 0.1 μ F ceramic capacitor with a 10 μ F Aluminum Electrolytic. The benefit is low ESR, high capacitance, and low overall cost.

A second capacitor is recommended between the input and ground to stabilize V_{IN} . The input capacitor should be at least 0.1 μ F to have a beneficial effect. All capacitors should be placed in close proximity to the pins. A "Quiet" ground termination is desirable. This can be achieved with a "Star" connection

■ Enable

The Enable pin is optional. EN for active high enable, \overline{EN} for active low enable. When disable the Enable Pin $EN=0$, $\overline{EN}=V_{IN}$, the PMOS pass transistor shuts off, and all internal circuits are powered down. In this state, the standby current is less than 1 μ A.

150mA Hi-PSRR, Low-Quiescent LDO with In-Rush Current Control For USB Application

AME8831

Output Voltage vs Load Current

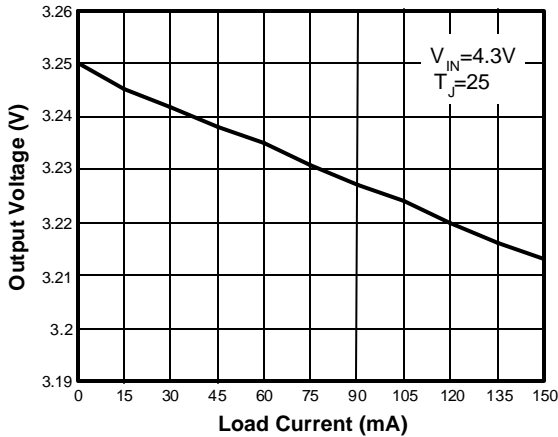

Output Noise Spectral Density

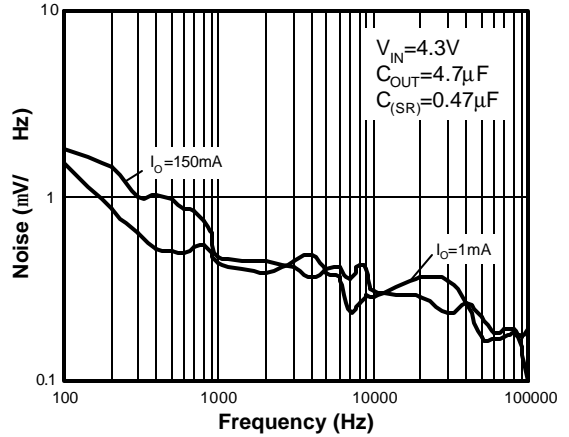

Quiescent Current vs Free Air Temp.

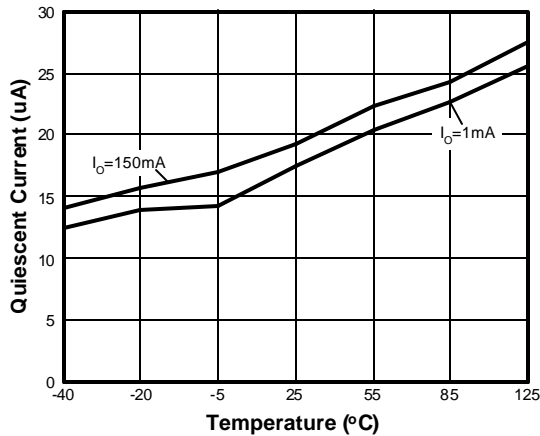

Output Impedance vs Frequency

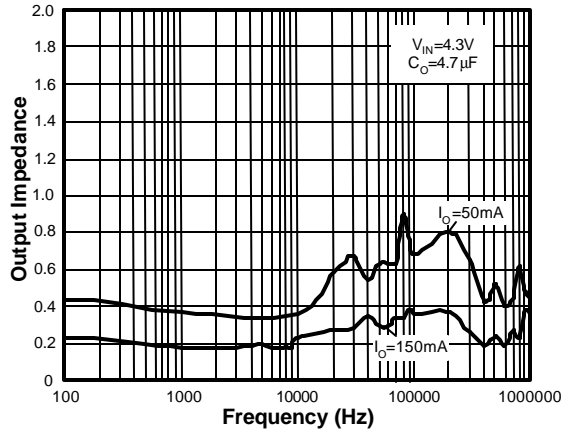

Dropout Voltage vs. Temperature

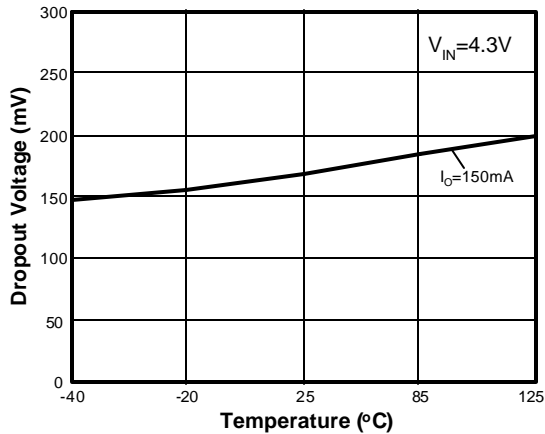

Ripple Rejection vs Frequency

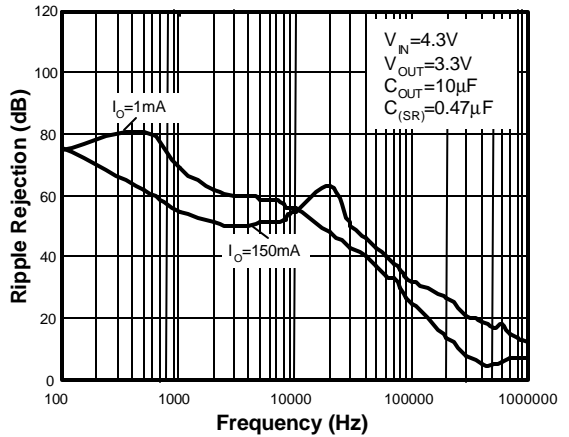

AME8831

Line Transient Response

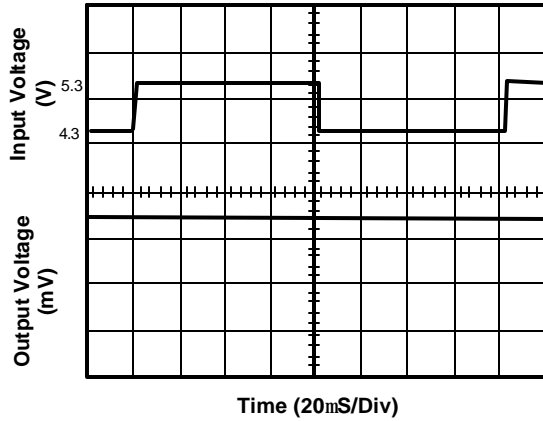

V_{OUT} vs Temperature

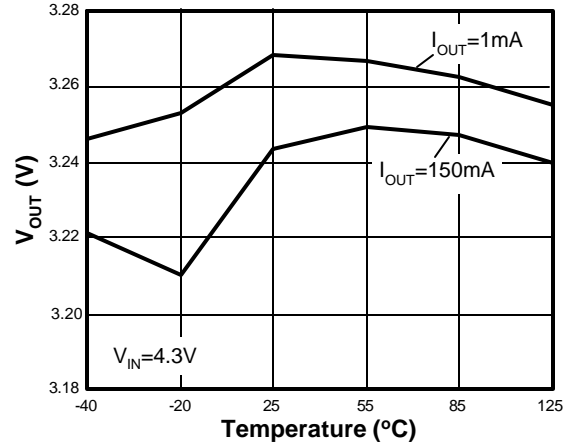

Output Voltage, Enable Voltage vs Time
(Start-Up)

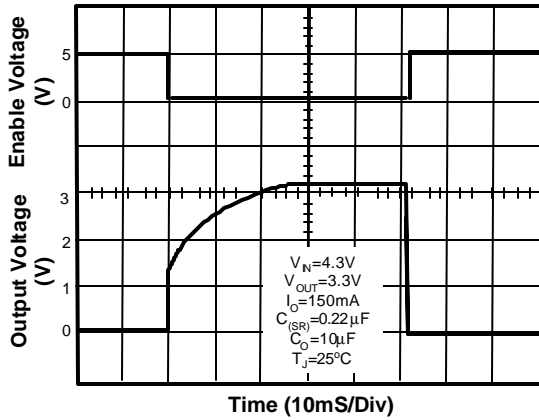

Output Voltage, Enable Voltage vs Time
(Start-Up)

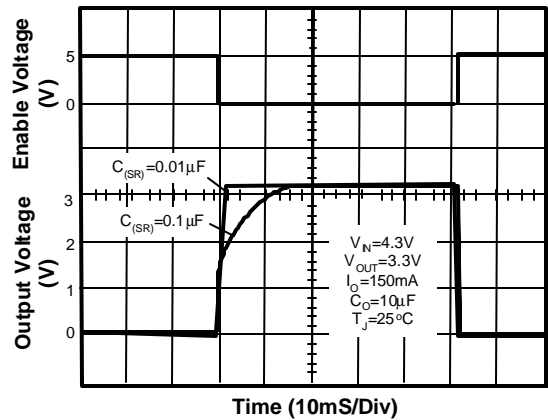

Load Transient Response

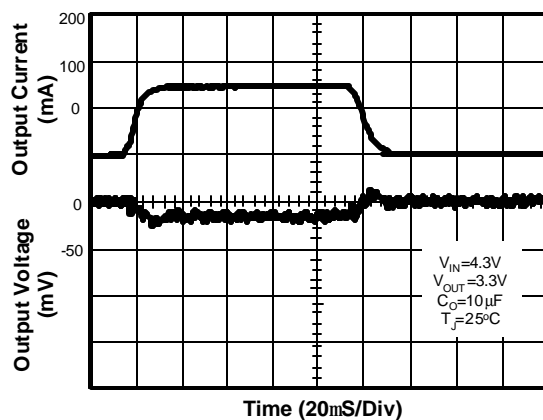

AME8831

■ **Date Code Rule**

Marking			Date Code		Year
A	A	A	W	W	xxx0
A	A	A	W	<u>W</u>	xxx1
A	A	A	<u>W</u>	W	xxx2
A	A	A	<u>W</u>	<u>W</u>	xxx3
A	A	<u>A</u>	W	W	xxx4
A	A	<u>A</u>	W	<u>W</u>	xxx5
A	A	<u>A</u>	<u>W</u>	W	xxx6
A	A	<u>A</u>	<u>W</u>	<u>W</u>	xxx7
A	<u>A</u>	A	W	W	xxx8
A	<u>A</u>	A	W	<u>W</u>	xxx9

■ **Tape and Reel Dimension**

SOT-25

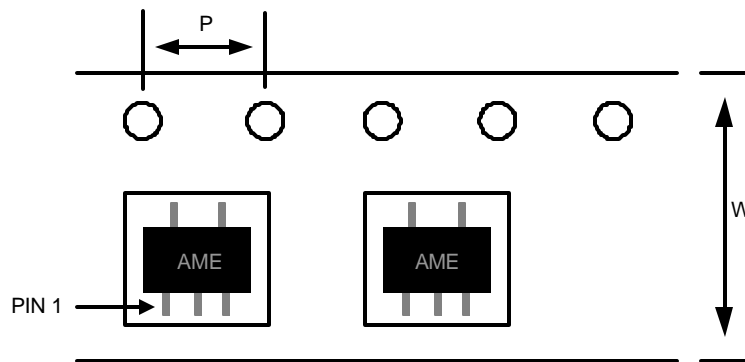

Carrier Tape, Number of Components Per Reel and Reel Size

Package	Carrier Width (W)	Pitch (P)	Part Per Full Reel	Reel Size
SOT-25	8.0±0.1 mm	4.0±0.1 mm	3000pcs	180±1 mm

AME8831

■ **Tape and Reel Dimension**

TSOT-25

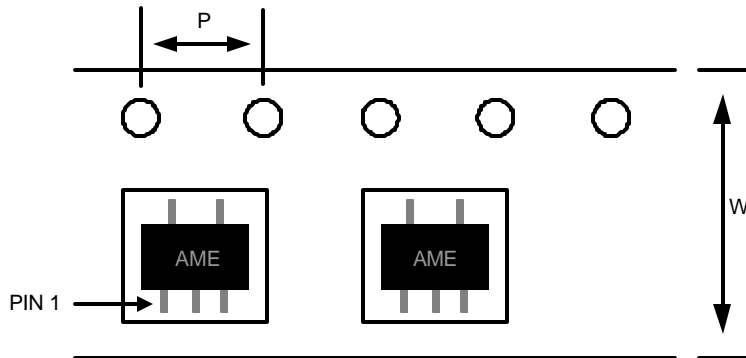

Carrier Tape, Number of Components Per Reel and Reel Size

Package	Carrier Width (W)	Pitch (P)	Part Per Full Reel	Reel Size
TSOT-25	8.0±0.1 mm	4.0±0.1 mm	3000pcs	180±1 mm

AME8831

■ Package Dimension

SOT-25

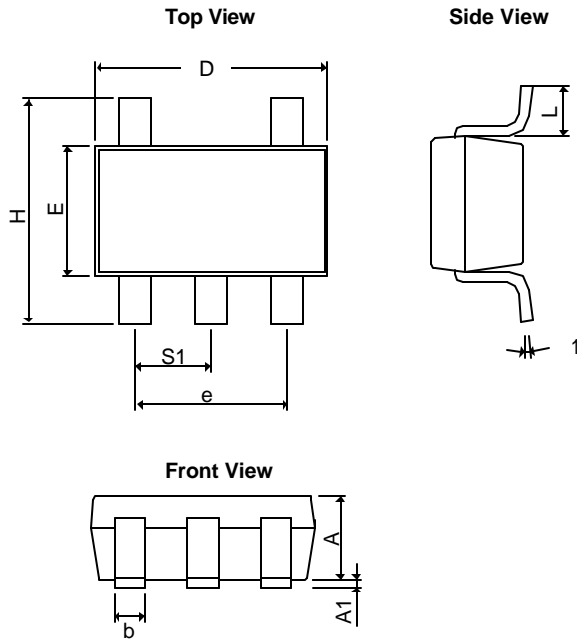

SYMBOLS	MILLIMETERS		INCHES	
	MIN	MAX	MIN	MAX
A	1.20REF		0.0472REF	
A ₁	0.00	0.15	0.0000	0.0059
b	0.30	0.55	0.0118	0.0217
D	2.70	3.10	0.1063	0.1220
E	1.40	1.80	0.0551	0.0709
e	1.90 BSC		0.07480 BSC	
H	2.60	3.00	0.10236	0.11811
L	0.37BSC		0.0146BSC	
q1	0°	10°	0°	10°
S ₁	0.95BSC		0.0374BSC	

TSOT-25

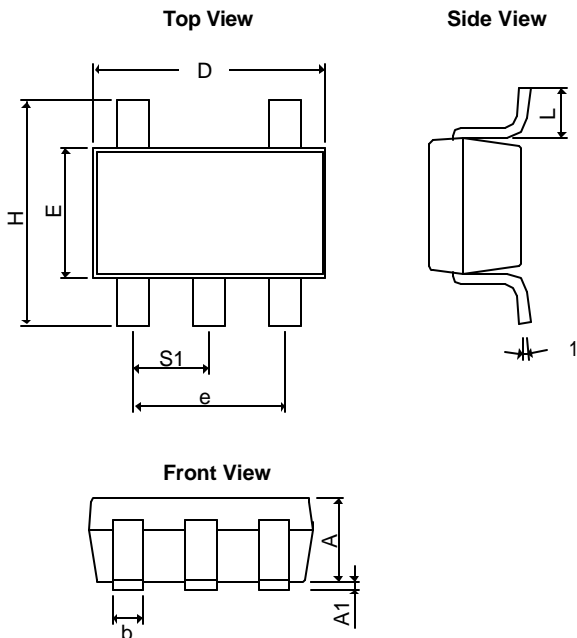

SYMBOLS	MILLIMETERS		INCHES	
	MIN	MAX	MIN	MAX
A+A ₁	0.90	1.25	0.0354	0.0492
b	0.30	0.50	0.0118	0.0197
c	0.09	0.25	0.0035	0.0098
D	2.70	3.10	0.1063	0.1220
E	1.40	1.80	0.0551	0.0709
e	1.90 BSC		0.07480 BSC	
H	2.40	3.00	0.09449	0.11811
L	0.35BSC		0.0138BSC	
q1	0°	10°	0°	10°
S ₁	0.95BSC		0.0374BSC	

[查询"AME8831"供应商](#)



www.ame.com.tw
E-Mail: sales@ame.com.tw

Life Support Policy:

These products of AME, Inc. are not authorized for use as critical components in life-support devices or systems, without the express written approval of the president of AME, Inc.

AME, Inc. reserves the right to make changes in the circuitry and specifications of its devices and advises its customers to obtain the latest version of relevant information.

© AME, Inc. , April 2006

Document: 1009-DS8831-A.01

Corporate Headquarter
AME, Inc.

2F, 302 Rui-Guang Road, Nei-Hu District
Taipei 114, Taiwan.
Tel: 886 2 2627-8687
Fax: 886 2 2659-2989

U.S.A.(Subsidiary)
Analog Microelectronics, Inc.

3100 De La Cruz Blvd., Suite 201
Santa Clara, CA. 95054-2046
Tel : (408) 988-2388
Fax: (408) 988-2489