

# LM2734Z

## Thin SOT23 1A Load Step-Down DC-DC Regulator

### General Description

The LM2734Z regulator is a monolithic, high frequency, PWM step-down DC/DC converter assembled in a 6-pin Thin SOT23 and LLP non pull back package. It provides all the active functions to provide local DC/DC conversion with fast transient response and accurate regulation in the smallest possible PCB area.

With a minimum of external components and online design support through WEBENCH<sup>®</sup>, the LM2734Z is easy to use. The ability to drive 1A loads with an internal 300mΩ NMOS switch using state-of-the-art 0.5μm BiCMOS technology results in the best power density available. The world class control circuitry allows for on-times as low as 13ns, thus supporting exceptionally high frequency conversion over the entire 3V to 20V input operating range down to the minimum output voltage of 0.8V. Switching frequency is internally set to 3MHz, allowing the use of extremely small surface mount inductors and chip capacitors. Even though the operating frequency is very high, efficiencies up to 85% are easy to achieve. External shutdown is included, featuring an ultra-low stand-by current of 30nA. The LM2734Z utilizes current-mode control and internal compensation to provide high-performance regulation over a wide range of operating conditions. Additional features include internal soft-start circuitry to reduce inrush current, pulse-by-pulse current limit, thermal shutdown, and output over-voltage protection.

### Features

- Thin SOT23-6 package, or 6 lead LLP package
- 3.0V to 20V input voltage range
- 0.8V to 18V output voltage range
- 1A output current
- 3MHz switching frequency
- 300mΩ NMOS switch
- 30nA shutdown current
- 0.8V, 2% internal voltage reference
- Internal soft-start
- Current-Mode, PWM operation
- Thermal shutdown

### Applications

- DSL Modems
- Local Point of Load Regulation
- Battery Powered Devices
- USB Powered Devices

### Typical Application Circuit

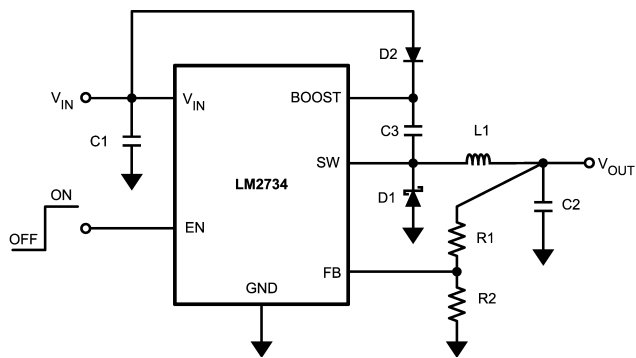

20130301

Efficiency vs Load Current  
 $V_{IN} = 5V, V_{OUT} = 3.3V$

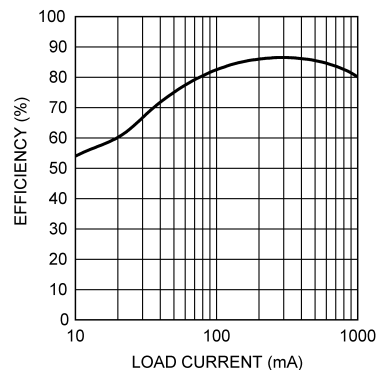

20130345

WEBENCH<sup>™</sup> is a trademark of Transim.

## Connection Diagrams

请向"LM2734ZMK"供应商

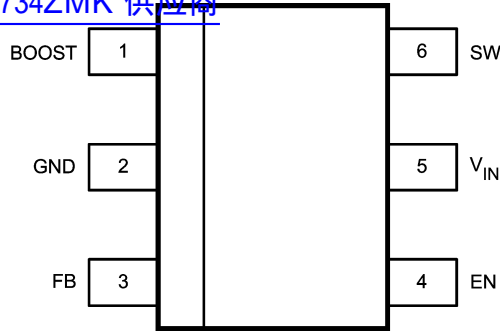

6-Lead TSOT  
NS Package Number MK06A

20130305

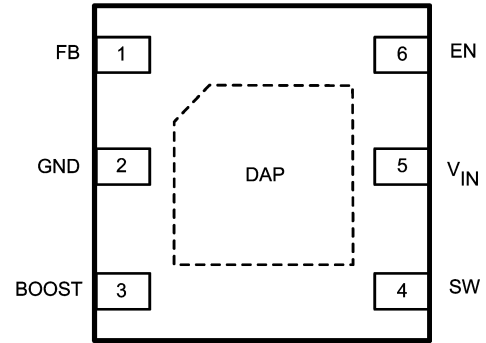

6-Lead LLP (3mm x 3mm)  
NS Package Number SDE06A

20130360

## Ordering Information

Order Number	Package Type	NSC Package Drawing	Package Marking	Supplied As
LM2734ZMK	TSOT-6	MK06A	SFTB	1000 Units on Tape and Reel
LM2734ZMKX	TSOT-6	MK06A	SFTB	3000 Units on Tape and Reel
LM2734ZSD	6-Lead LLP	SDE06A	L163B	1000 Units on Tape and Reel
LM2734ZSDX	6-Lead LLP	SDE06A	L163B	4500 Units on Tape and Reel

\* Contact the local sales office for the lead-free package.

## Pin Description

Pin	Name	Function
1	BOOST	Boost voltage that drives the internal NMOS control switch. A bootstrap capacitor is connected between the BOOST and SW pins.
2	GND	Signal and Power ground pin. Place the bottom resistor of the feedback network as close as possible to this pin for accurate regulation.
3	FB	Feedback pin. Connect FB to the external resistor divider to set output voltage.
4	EN	Enable control input. Logic high enables operation. Do not allow this pin to float or be greater than $V_{IN} + 0.3V$ .
5	$V_{IN}$	Input supply voltage. Connect a bypass capacitor to this pin.
6	SW	Output switch. Connects to the inductor, catch diode, and bootstrap capacitor.
DAP	GND	The Die Attach Pad is internally connected to GND

**Absolute Maximum Ratings** (Note 1)

If **ilitary/Aerospace specified devices are required, please contact the National Semiconductor Sales Office/Distributors for availability and specifications.**

$V_{IN}$	-0.5V to 24V
SW Voltage	-0.5V to 24V
Boost Voltage	-0.5V to 30V
Boost to SW Voltage	-0.5V to 6.0V
FB Voltage	-0.5V to 3.0V
EN Voltage	-0.5V to ( $V_{IN} + 0.3V$ )
Junction Temperature	150°C
ESD Susceptibility (Note 2)	2kV
Storage Temp. Range	-65°C to 150°C

## Soldering Information

Infrared/Convection Reflow (15sec)	220°C
Wave Soldering Lead Temp. (10sec)	260°C

**Operating Ratings** (Note 1)

$V_{IN}$	3V to 20V
SW Voltage	-0.5V to 20V
Boost Voltage	-0.5V to 25V
Boost to SW Voltage	1.6V to 5.5V
Junction Temperature Range	-40°C to +125°C
Thermal Resistance $\theta_{JA}$ (Note 3)	TSOT23-6 118°C/W

**Electrical Characteristics**

Specifications with standard typeface are for  $T_J = 25^\circ\text{C}$ , and those in **boldface type** apply over the full **Operating Temperature Range** ( $T_J = -40^\circ\text{C}$  to  $125^\circ\text{C}$ ).  $V_{IN} = 5V$ ,  $V_{BOOST} - V_{SW} = 5V$  unless otherwise specified. Datasheet min/max specification limits are guaranteed by design, test, or statistical analysis.

Symbol	Parameter	Conditions	Min (Note 4)	Typ (Note 5)	Max (Note 4)	Units
$V_{FB}$	Feedback Voltage		<b>0.784</b>	0.800	<b>0.816</b>	V
$\Delta V_{FB}/\Delta V_{IN}$	Feedback Voltage Line Regulation	$V_{IN} = 3V$ to $20V$		0.01		% / V
$I_{FB}$	Feedback Input Bias Current	Sink/Source		10	<b>250</b>	nA
UVLO	Undervoltage Lockout	$V_{IN}$ Rising		2.74	<b>2.90</b>	V
	Undervoltage Lockout	$V_{IN}$ Falling	<b>2.0</b>	2.3		
	UVLO Hysteresis		<b>0.30</b>	0.44	<b>0.62</b>	
$F_{SW}$	Switching Frequency		<b>2.2</b>	3.0	<b>3.6</b>	MHz
$D_{MAX}$	Maximum Duty Cycle		<b>78</b>	85		%
$D_{MIN}$	Minimum Duty Cycle			8		%
$R_{DS(ON)}$	Switch ON Resistance	$V_{BOOST} - V_{SW} = 3V$ (TSOT Package)		300	<b>600</b>	m $\Omega$
		$V_{BOOST} - V_{SW} = 3V$ (LLP Package)		340	<b>650</b>	m $\Omega$
$I_{CL}$	Switch Current Limit	$V_{BOOST} - V_{SW} = 3V$	<b>1.2</b>	1.7	<b>2.5</b>	A
$I_Q$	Quiescent Current	Switching		1.5	<b>2.5</b>	mA
	Quiescent Current (shutdown)	$V_{EN} = 0V$		30		nA
$I_{BOOST}$	Boost Pin Current	(Switching)		4.25	<b>6</b>	mA
$V_{EN\_TH}$	Shutdown Threshold Voltage	$V_{EN}$ Falling			<b>0.4</b>	V
	Enable Threshold Voltage	$V_{EN}$ Rising	<b>1.8</b>			
$I_{EN}$	Enable Pin Current	Sink/Source		10		nA
$I_{SW}$	Switch Leakage			40		nA

**Note 1:** Absolute Maximum Ratings indicate limits beyond which damage to the device may occur. Operating Ratings indicate conditions for which the device is intended to be functional, but specific performance is not guaranteed. For guaranteed specifications and the test conditions, see Electrical Characteristics.

**Note 2:** Human body model, 1.5k $\Omega$  in series with 100pF.

**Note 3:** Thermal shutdown will occur if the junction temperature exceeds 165°C. The maximum power dissipation is a function of  $T_{J(MAX)}$ ,  $\theta_{JA}$  and  $T_A$ . The maximum allowable power dissipation at any ambient temperature is  $P_D = (T_{J(MAX)} - T_A)/\theta_{JA}$ . All numbers apply for packages soldered directly onto a 3" x 3" PC board with 2oz. copper on 4 layers in still air. For a 2 layer board using 1 oz. copper in still air,  $\theta_{JA} = 204^\circ\text{C/W}$ .

**Note 4:** Guaranteed to National's Average Outgoing Quality Level (AOQL).

**Note 5:** Typicals represent the most likely parametric norm.

# Typical Performance Characteristics

All curves taken at  $V_{IN} = 5V$ ,  $V_{BOOST} - V_{SW} = 5V$ ,  $L1 = 2.2 \mu H$   
 代理商: LM2734Z (LW) 供应商: LM2734Z (LW) 代理商: LM2734Z (LW) 供应商: LM2734Z (LW)

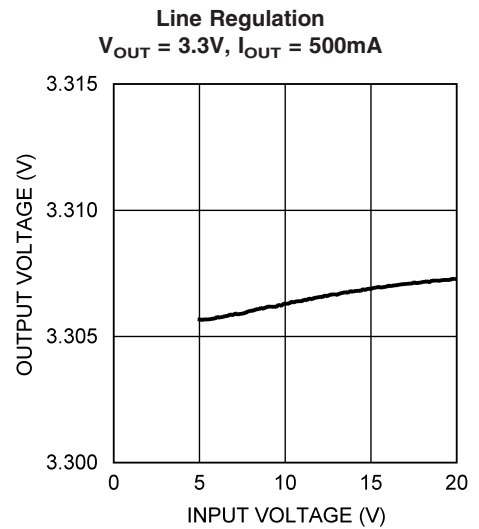
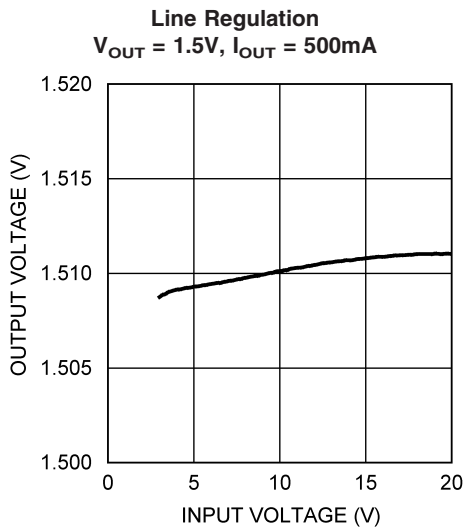
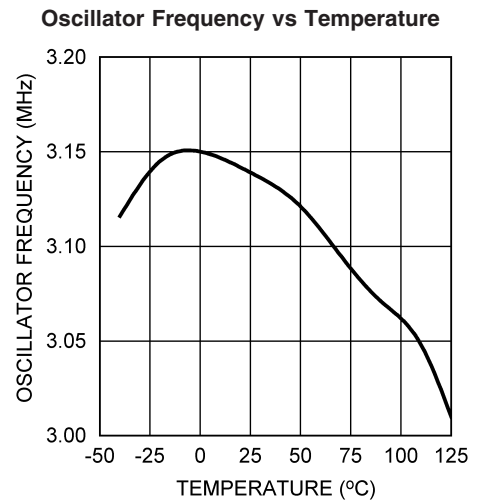
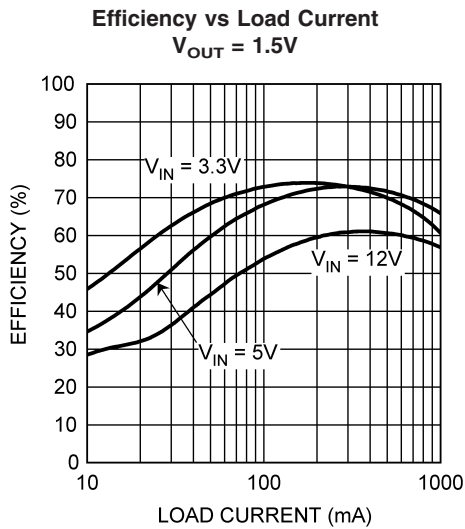
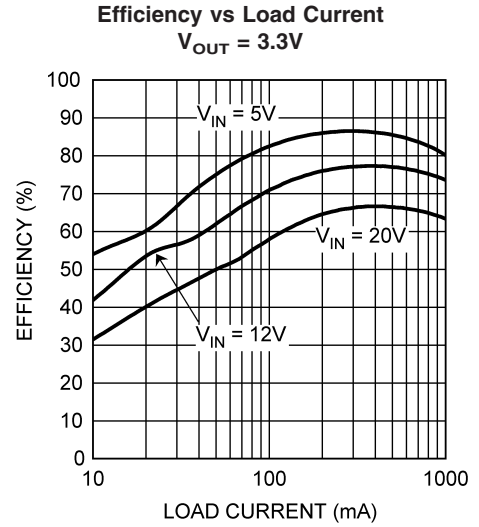
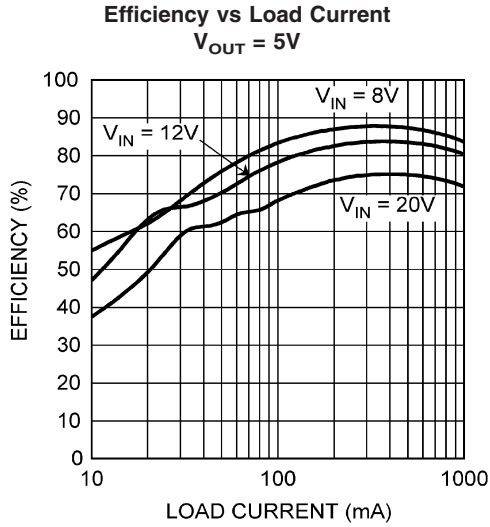

## Block Diagram

查询"LM2734ZMK"供应商

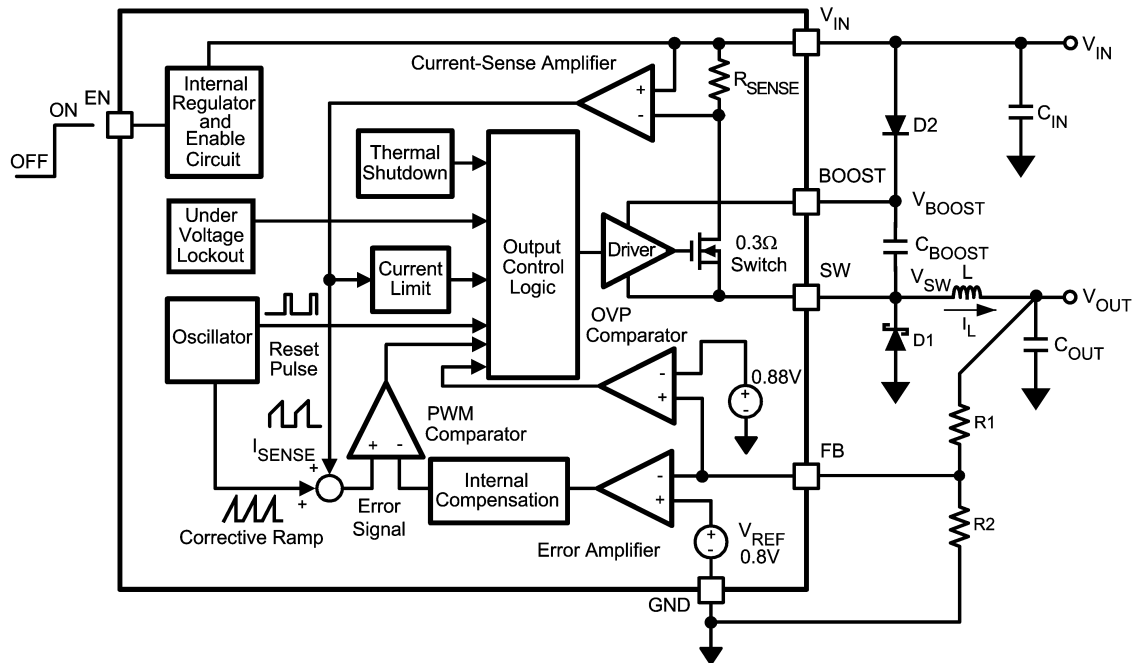

20130306

FIGURE 1.

## Application Information

## THEORY OF OPERATION

The LM2734Z is a constant frequency PWM buck regulator IC that delivers a 1A load current. The regulator has a preset switching frequency of 3MHz. This high frequency allows the LM2734Z to operate with small surface mount capacitors and inductors, resulting in a DC/DC converter that requires a minimum amount of board space. The LM2734Z is internally compensated, so it is simple to use, and requires few external components. The LM2734Z uses current-mode control to regulate the output voltage.

The following operating description of the LM2734Z will refer to the Simplified Block Diagram (Figure 1) and to the waveforms in Figure 2. The LM2734Z supplies a regulated output voltage by switching the internal NMOS control switch at constant frequency and variable duty cycle. A switching cycle begins at the falling edge of the reset pulse generated by the internal oscillator. When this pulse goes low, the output control logic turns on the internal NMOS control switch. During this on-time, the SW pin voltage ( $V_{SW}$ ) swings up to approximately  $V_{IN}$ , and the inductor current ( $I_L$ ) increases with a linear slope.  $I_L$  is measured by the current-sense amplifier, which generates an output proportional to the switch current. The sense signal is summed with the regulator's corrective ramp and compared to the error amplifier's output, which is proportional to the difference between the feedback voltage and  $V_{REF}$ . When the PWM comparator output goes high, the output switch turns off until the next switching cycle begins. During the switch off-time, inductor current discharges through Schottky diode D1, which forces the SW pin to swing below ground by the

forward voltage ( $V_D$ ) of the catch diode. The regulator loop adjusts the duty cycle ( $D$ ) to maintain a constant output voltage.

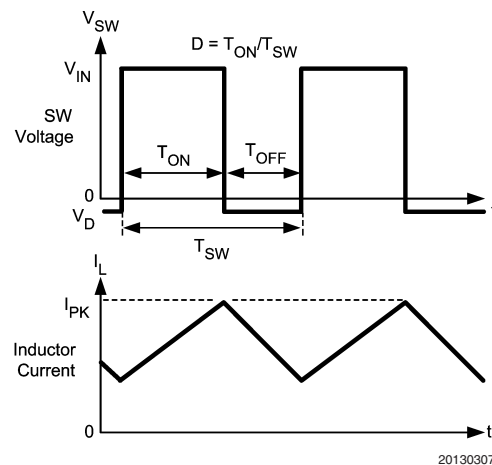

20130307

FIGURE 2. LM2734Z Waveforms of SW Pin Voltage and Inductor Current

## BOOST FUNCTION

Capacitor  $C_{BOOST}$  and diode D2 in Figure 3 are used to generate a voltage  $V_{BOOST}$ .  $V_{BOOST} - V_{SW}$  is the gate drive voltage to the internal NMOS control switch. To properly drive the internal NMOS switch during its on-time,  $V_{BOOST}$  needs to be at least 1.6V greater than  $V_{SW}$ . Although the LM2734Z will operate with this minimum voltage, it may not have sufficient gate drive to supply large values of output

## Application Information (Continued)

current. Therefore, it is recommended that  $V_{\text{BOOST}}$  be greater than 2.5V above  $V_{\text{SW}}$  for best efficiency.  $V_{\text{BOOST}} - V_{\text{SW}}$  should not exceed the maximum operating limit of 5.5V.  $5.5\text{V} > V_{\text{BOOST}} - V_{\text{SW}} > 2.5\text{V}$  for best performance.

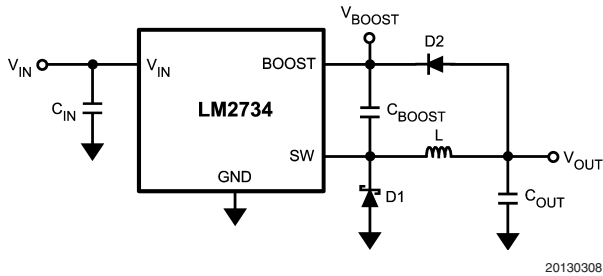

FIGURE 3.  $V_{\text{OUT}}$  Charges  $C_{\text{BOOST}}$

When the LM2734Z starts up, internal circuitry from the BOOST pin supplies a maximum of 20mA to  $C_{\text{BOOST}}$ . This current charges  $C_{\text{BOOST}}$  to a voltage sufficient to turn the switch on. The BOOST pin will continue to source current to  $C_{\text{BOOST}}$  until the voltage at the feedback pin is greater than 0.76V.

There are various methods to derive  $V_{\text{BOOST}}$ :

1. From the input voltage ( $V_{\text{IN}}$ )
2. From the output voltage ( $V_{\text{OUT}}$ )
3. From an external distributed voltage rail ( $V_{\text{EXT}}$ )
4. From a shunt or series zener diode

In the Simplified Block Diagram of *Figure 1*, capacitor  $C_{\text{BOOST}}$  and diode D2 supply the gate-drive current for the NMOS switch. Capacitor  $C_{\text{BOOST}}$  is charged via diode D2 by  $V_{\text{IN}}$ . During a normal switching cycle, when the internal NMOS control switch is off ( $T_{\text{OFF}}$ ) (refer to *Figure 2*),  $V_{\text{BOOST}}$  equals  $V_{\text{IN}}$  minus the forward voltage of D2 ( $V_{\text{FD2}}$ ), during which the current in the inductor (L) forward biases the Schottky diode D1 ( $V_{\text{FD1}}$ ). Therefore the voltage stored across  $C_{\text{BOOST}}$  is

$$V_{\text{BOOST}} - V_{\text{SW}} = V_{\text{IN}} - V_{\text{FD2}} + V_{\text{FD1}}$$

When the NMOS switch turns on ( $T_{\text{ON}}$ ), the switch pin rises to

$$V_{\text{SW}} = V_{\text{IN}} - (R_{\text{DSON}} \times I_{\text{L}}),$$

forcing  $V_{\text{BOOST}}$  to rise thus reverse biasing D2. The voltage at  $V_{\text{BOOST}}$  is then

$$V_{\text{BOOST}} = 2V_{\text{IN}} - (R_{\text{DSON}} \times I_{\text{L}}) - V_{\text{FD2}} + V_{\text{FD1}}$$

which is approximately

$$2V_{\text{IN}} - 0.4\text{V}$$

for many applications. Thus the gate-drive voltage of the NMOS switch is approximately

$$V_{\text{IN}} - 0.2\text{V}$$

An alternate method for charging  $C_{\text{BOOST}}$  is to connect D2 to the output as shown in *Figure 3*. The output voltage should be between 2.5V and 5.5V, so that proper gate voltage will be applied to the internal switch. In this circuit,  $C_{\text{BOOST}}$  provides a gate drive voltage that is slightly less than  $V_{\text{OUT}}$ . In applications where both  $V_{\text{IN}}$  and  $V_{\text{OUT}}$  are greater than 5.5V, or less than 3V,  $C_{\text{BOOST}}$  cannot be charged directly from these voltages. If  $V_{\text{IN}}$  and  $V_{\text{OUT}}$  are greater than 5.5V,  $C_{\text{BOOST}}$  can be charged from  $V_{\text{IN}}$  or  $V_{\text{OUT}}$  minus a zener voltage by placing a zener diode D3 in series with D2, as

shown in *Figure 4*. When using a series zener diode from the input, ensure that the regulation of the input supply doesn't create a voltage that falls outside the recommended  $V_{\text{BOOST}}$  voltage.

$$(V_{\text{INMAX}} - V_{\text{D3}}) < 5.5\text{V}$$

$$(V_{\text{INMIN}} - V_{\text{D3}}) > 1.6\text{V}$$

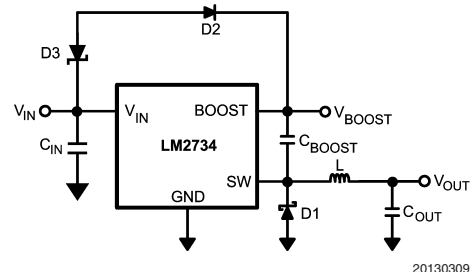

FIGURE 4. Zener Reduces Boost Voltage from  $V_{\text{IN}}$

An alternative method is to place the zener diode D3 in a shunt configuration as shown in *Figure 5*. A small 350mW to 500mW 5.1V zener in a SOT-23 or SOD package can be used for this purpose. A small ceramic capacitor such as a 6.3V, 0.1 $\mu\text{F}$  capacitor ( $C_4$ ) should be placed in parallel with the zener diode. When the internal NMOS switch turns on, a pulse of current is drawn to charge the internal NMOS gate capacitance. The 0.1  $\mu\text{F}$  parallel shunt capacitor ensures that the  $V_{\text{BOOST}}$  voltage is maintained during this time.

Resistor R3 should be chosen to provide enough RMS current to the zener diode (D3) and to the BOOST pin. A recommended choice for the zener current ( $I_{\text{ZENER}}$ ) is 1 mA. The current  $I_{\text{BOOST}}$  into the BOOST pin supplies the gate current of the NMOS control switch and varies typically according to the following formula:

$$I_{\text{BOOST}} = (D + 0.5) \times (V_{\text{ZENER}} - V_{\text{D2}}) \text{ mA}$$

where D is the duty cycle,  $V_{\text{ZENER}}$  and  $V_{\text{D2}}$  are in volts, and  $I_{\text{BOOST}}$  is in milliamps.  $V_{\text{ZENER}}$  is the voltage applied to the anode of the boost diode (D2), and  $V_{\text{D2}}$  is the average forward voltage across D2. Note that this formula for  $I_{\text{BOOST}}$  gives typical current. For the worst case  $I_{\text{BOOST}}$ , increase the current by 25%. In that case, the worst case boost current will be

$$I_{\text{BOOST-MAX}} = 1.25 \times I_{\text{BOOST}}$$

R3 will then be given by

$$R3 = (V_{\text{IN}} - V_{\text{ZENER}}) / (1.25 \times I_{\text{BOOST}} + I_{\text{ZENER}})$$

For example, let  $V_{\text{IN}} = 10\text{V}$ ,  $V_{\text{ZENER}} = 5\text{V}$ ,  $V_{\text{D2}} = 0.7\text{V}$ ,  $I_{\text{ZENER}} = 1\text{mA}$ , and duty cycle D = 50%. Then

$$I_{\text{BOOST}} = (0.5 + 0.5) \times (5 - 0.7) \text{ mA} = 4.3\text{mA}$$

$$R3 = (10\text{V} - 5\text{V}) / (1.25 \times 4.3\text{mA} + 1\text{mA}) = 787\Omega$$

## Application Information (Continued)

[查询"LM2734ZMK"供应商](#)

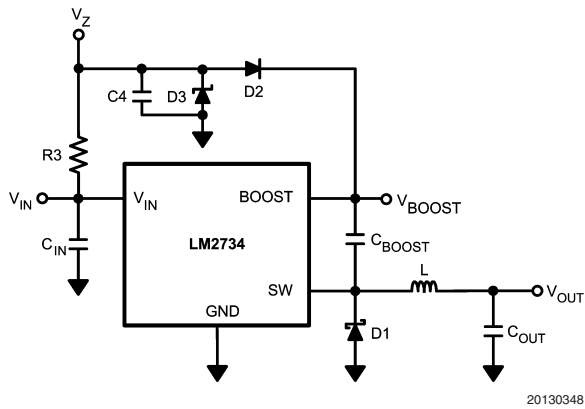

FIGURE 5. Boost Voltage Supplied from the Shunt Zener on  $V_{IN}$

### ENABLE PIN / SHUTDOWN MODE

The LM2734Z has a shutdown mode that is controlled by the enable pin (EN). When a logic low voltage is applied to EN, the part is in shutdown mode and its quiescent current drops to typically 30nA. Switch leakage adds another 40nA from the input supply. The voltage at this pin should never exceed  $V_{IN} + 0.3V$ .

### SOFT-START

This function forces  $V_{OUT}$  to increase at a controlled rate during start up. During soft-start, the error amplifier's reference voltage ramps from 0V to its nominal value of 0.8V in approximately 200 $\mu$ s. This forces the regulator output to ramp up in a more linear and controlled fashion, which helps reduce inrush current.

### OUTPUT OVERVOLTAGE PROTECTION

The overvoltage comparator compares the FB pin voltage to a voltage that is 10% higher than the internal reference  $V_{ref}$ . Once the FB pin voltage goes 10% above the internal reference, the internal NMOS control switch is turned off, which allows the output voltage to decrease toward regulation.

### UNDERVOLTAGE LOCKOUT

Undervoltage lockout (UVLO) prevents the LM2734Z from operating until the input voltage exceeds 2.74V(typ).

The UVLO threshold has approximately 440mV of hysteresis, so the part will operate until  $V_{IN}$  drops below 2.3V(typ). Hysteresis prevents the part from turning off during power up if  $V_{IN}$  is non-monotonic.

### CURRENT LIMIT

The LM2734Z uses cycle-by-cycle current limiting to protect the output switch. During each switching cycle, a current limit comparator detects if the output switch current exceeds 1.7A (typ), and turns off the switch until the next switching cycle begins.

### THERMAL SHUTDOWN

Thermal shutdown limits total power dissipation by turning off the output switch when the IC junction temperature exceeds 165°C. After thermal shutdown occurs, the output switch doesn't turn on until the junction temperature drops to approximately 150°C.

## Design Guide

### INDUCTOR SELECTION

The Duty Cycle (D) can be approximated quickly using the ratio of output voltage ( $V_O$ ) to input voltage ( $V_{IN}$ ):

$$D = \frac{V_O}{V_{IN}}$$

The catch diode (D1) forward voltage drop and the voltage drop across the internal NMOS must be included to calculate a more accurate duty cycle. Calculate D by using the following formula:

$$D = \frac{V_O + V_D}{V_{IN} + V_D - V_{SW}}$$

$V_{SW}$  can be approximated by:

$$V_{SW} = I_O \times R_{DS(ON)}$$

The diode forward drop ( $V_D$ ) can range from 0.3V to 0.7V depending on the quality of the diode. The lower  $V_D$  is, the higher the operating efficiency of the converter.

The inductor value determines the output ripple current. Lower inductor values decrease the size of the inductor, but increase the output ripple current. An increase in the inductor value will decrease the output ripple current. The ratio of ripple current ( $\Delta I_L$ ) to output current ( $I_O$ ) is optimized when it is set between 0.3 and 0.4 at 1A. The ratio  $r$  is defined as:

$$r = \frac{\Delta I_L}{I_O}$$

One must also ensure that the minimum current limit (1.2A) is not exceeded, so the peak current in the inductor must be calculated. The peak current ( $I_{LPK}$ ) in the inductor is calculated by:

$$I_{LPK} = I_O + \Delta I_L/2$$

If  $r = 0.5$  at an output of 1A, the peak current in the inductor will be 1.25A. The minimum guaranteed current limit over all operating conditions is 1.2A. One can either reduce  $r$  to 0.4 resulting in a 1.2A peak current, or make the engineering judgement that 50mA over will be safe enough with a 1.7A typical current limit and 6 sigma limits. When the designed maximum output current is reduced, the ratio  $r$  can be increased. At a current of 0.1A,  $r$  can be made as high as 0.9. The ripple ratio can be increased at lighter loads because the net ripple is actually quite low, and if  $r$  remains constant the inductor value can be made quite large. An equation empirically developed for the maximum ripple ratio at any current below 2A is:

$$r = 0.387 \times I_{OUT}^{-0.3667}$$

Note that this is just a guideline.

## Design Guide (Continued)

LM2734ZMK"供应商

The LM2734Z operates at frequencies allowing the use of ceramic output capacitors without compromising transient response. Ceramic capacitors allow higher inductor ripple without significantly increasing output ripple. See the output capacitor section for more details on calculating output voltage ripple.

Now that the ripple current or ripple ratio is determined, the inductance is calculated by:

$$L = \frac{V_O + V_D}{I_O \times r \times f_s} \times (1-D)$$

where  $f_s$  is the switching frequency and  $I_O$  is the output current. When selecting an inductor, make sure that it is capable of supporting the peak output current without saturating. Inductor saturation will result in a sudden reduction in inductance and prevent the regulator from operating correctly. Because of the speed of the internal current limit, the peak current of the inductor need only be specified for the required maximum output current. For example, if the designed maximum output current is 0.5A and the peak current is 0.7A, then the inductor should be specified with a saturation current limit of >0.7A. There is no need to specify the saturation or peak current of the inductor at the 1.7A typical switch current limit. The difference in inductor size is a factor of 5. Because of the operating frequency of the LM2734Z, ferrite based inductors are preferred to minimize core losses. This presents little restriction since the variety of ferrite based inductors is huge. Lastly, inductors with lower series resistance (DCR) will provide better operating efficiency. For recommended inductors see Example Circuits.

### INPUT CAPACITOR

An input capacitor is necessary to ensure that  $V_{IN}$  does not drop excessively during switching transients. The primary specifications of the input capacitor are capacitance, voltage, RMS current rating, and ESL (Equivalent Series Inductance). The recommended input capacitance is 10 $\mu$ F, although 4.7 $\mu$ F works well for input voltages below 6V. The input voltage rating is specifically stated by the capacitor manufacturer. Make sure to check any recommended deratings and also verify if there is any significant change in capacitance at the operating input voltage and the operating temperature. The input capacitor maximum RMS input current rating ( $I_{RMS-IN}$ ) must be greater than:

$$I_{RMS-IN} = I_O \times \sqrt{D \times \left(1-D + \frac{r^2}{12}\right)}$$

It can be shown from the above equation that maximum RMS capacitor current occurs when  $D = 0.5$ . Always calculate the RMS at the point where the duty cycle,  $D$ , is closest to 0.5. The ESL of an input capacitor is usually determined by the effective cross sectional area of the current path. A large leaded capacitor will have high ESL and a 0805 ceramic chip capacitor will have very low ESL. At the operating frequencies of the LM2734Z, certain capacitors may have an ESL so large that the resulting impedance ( $2\pi fL$ ) will be higher than that required to provide stable operation. As a result, surface mount capacitors are strongly recommended. Sanyo POSCAP, Tantalum or Niobium, Panasonic SP or Cornell Dubilier ESR, and multilayer ceramic capacitors (MLCC) are all good choices for both input and output ca-

pacitors and have very low ESL. For MLCCs it is recommended to use X7R or X5R dielectrics. Consult capacitor manufacturer datasheet to see how rated capacitance varies over operating conditions.

### OUTPUT CAPACITOR

The output capacitor is selected based upon the desired output ripple and transient response. The initial current of a load transient is provided mainly by the output capacitor. The output ripple of the converter is:

$$\Delta V_O = \Delta i_L \times \left( R_{ESR} + \frac{1}{8 \times f_s \times C_O} \right)$$

When using MLCCs, the ESR is typically so low that the capacitive ripple may dominate. When this occurs, the output ripple will be approximately sinusoidal and 90° phase shifted from the switching action. Given the availability and quality of MLCCs and the expected output voltage of designs using the LM2734Z, there is really no need to review any other capacitor technologies. Another benefit of ceramic capacitors is their ability to bypass high frequency noise. A certain amount of switching edge noise will couple through parasitic capacitances in the inductor to the output. A ceramic capacitor will bypass this noise while a tantalum will not. Since the output capacitor is one of the two external components that control the stability of the regulator control loop, most applications will require a minimum at 10  $\mu$ F of output capacitance. Capacitance can be increased significantly with little detriment to the regulator stability. Like the input capacitor, recommended multilayer ceramic capacitors are X7R or X5R. Again, verify actual capacitance at the desired operating voltage and temperature.

Check the RMS current rating of the capacitor. The RMS current rating of the capacitor chosen must also meet the following condition:

$$I_{RMS-OUT} = I_O \times \frac{r}{\sqrt{12}}$$

### CATCH DIODE

The catch diode (D1) conducts during the switch off-time. A Schottky diode is recommended for its fast switching times and low forward voltage drop. The catch diode should be chosen so that its current rating is greater than:

$$I_{D1} = I_O \times (1-D)$$

The reverse breakdown rating of the diode must be at least the maximum input voltage plus appropriate margin. To improve efficiency choose a Schottky diode with a low forward voltage drop.

### BOOST DIODE

A standard diode such as the 1N4148 type is recommended. For  $V_{BOOST}$  circuits derived from voltages less than 3.3V, a small-signal Schottky diode is recommended for greater efficiency. A good choice is the BAT54 small signal diode.

### BOOST CAPACITOR

A ceramic 0.01 $\mu$ F capacitor with a voltage rating of at least 6.3V is sufficient. The X7R and X5R MLCCs provide the best performance.



## Design Guide (Continued)

### OUTPUT VOLTAGE

The output voltage is set using the following equation where R2 is connected between the FB pin and GND, and R1 is connected between V<sub>O</sub> and the FB pin. A good value for R2 is 10kΩ.

$$R1 = \left( \frac{V_O}{V_{REF}} - 1 \right) \times R2$$

## PCB Layout Considerations

When planning layout there are a few things to consider when trying to achieve a clean, regulated output. The most important consideration when completing the layout is the close coupling of the GND connections of the C<sub>IN</sub> capacitor and the catch diode D1. These ground ends should be close to one another and be connected to the GND plane with at least two through-holes. Place these components as close to the IC as possible. Next in importance is the location of the GND connection of the C<sub>OUT</sub> capacitor, which should be near the GND connections of C<sub>IN</sub> and D1.

There should be a continuous ground plane on the bottom layer of a two-layer board except under the switching node island.

The FB pin is a high impedance node and care should be taken to make the FB trace short to avoid noise pickup and inaccurate regulation. The feedback resistors should be placed as close as possible to the IC, with the GND of R2 placed as close as possible to the GND of the IC. The V<sub>OUT</sub> trace to R1 should be routed away from the inductor and any other traces that are switching.

High AC currents flow through the V<sub>IN</sub>, SW and V<sub>OUT</sub> traces, so they should be as short and wide as possible. However, making the traces wide increases radiated noise, so the designer must make this trade-off. Radiated noise can be decreased by choosing a shielded inductor.

The remaining components should also be placed as close as possible to the IC. Please see Application Note AN-1229 for further considerations and the LM2734Z demo board as an example of a four-layer layout.

## Calculating Efficiency, and Junction Temperature:

The complete LM2734Z DC/DC converter efficiency can be calculated in the following manner.

$$\eta = \frac{P_{OUT}}{P_{IN}}$$

Or

$$\eta = \frac{P_{OUT}}{P_{OUT} + P_{LOSS}}$$

Calculations for determining the most significant power losses are shown below. Other losses totaling less than 2% are not discussed.

Power loss (P<sub>LOSS</sub>) is the sum of two basic types of losses in the converter, switching and conduction. Conduction losses usually dominate at higher output loads, where as switching losses remain relatively fixed and dominate at lower output loads. The first step in determining the losses is to calculate the duty cycle (D).

$$D = \frac{V_{OUT} + V_D}{V_{IN} + V_D - V_{SW}}$$

V<sub>SW</sub> is the voltage drop across the internal NFET when it is on, and is equal to:

$$V_{SW} = I_{OUT} \times R_{DS(on)}$$

V<sub>D</sub> is the forward voltage drop across the Schottky diode. It can be obtained from the Electrical Characteristics section. If the voltage drop across the inductor (V<sub>DCR</sub>) is accounted for, the equation becomes:

$$D = \frac{V_O + V_D + V_{DCR}}{V_{IN} + V_D - V_{SW}}$$

This usually gives only a minor duty cycle change, and has been omitted in the examples for simplicity.

The conduction losses in the free-wheeling Schottky diode are calculated as follows:

$$P_{DIODE} = V_D \times I_{OUT}(1-D)$$

Often this is the single most significant power loss in the circuit. Care should be taken to choose a Schottky diode that has a low forward voltage drop.

Another significant external power loss is the conduction loss in the output inductor. The equation can be simplified to:

$$P_{IND} = I_{OUT}^2 \times R_{DCR}$$

The LM2734Z conduction loss is mainly associated with the internal NFET:

$$P_{COND} = I_{OUT}^2 \times R_{DS(on)} \times D$$

Switching losses are also associated with the internal NFET. They occur during the switch on and off transition periods, where voltages and currents overlap resulting in power loss. The simplest means to determine this loss is to empirically measure the rise and fall times (10% to 90%) of the switch at the switch node:

$$P_{SWF} = 1/2(V_{IN} \times I_{OUT} \times \text{freq} \times T_{FALL})$$

$$P_{SWR} = 1/2(V_{IN} \times I_{OUT} \times \text{freq} \times T_{RISE})$$

$$P_{SW} = P_{SWF} + P_{SWR}$$

### Typical Rise and Fall Times vs Input Voltage

V <sub>IN</sub>	T <sub>RISE</sub>	T <sub>FALL</sub>
5V	8ns	4ns
10V	9ns	6ns
15V	10ns	7ns

Another loss is the power required for operation of the internal circuitry:

$$P_Q = I_Q \times V_{IN}$$

I<sub>Q</sub> is the quiescent operating current, and is typically around 1.5mA. The other operating power that needs to be calculated is that required to drive the internal NFET:

$$P_{BOOST} = I_{BOOST} \times V_{BOOST}$$

## Calculating Efficiency, and

### Junction Temperature: (Continued)

$V_{\text{BOOST}}$  is normally between 3VDC and 5VDC. The  $I_{\text{BOOST}}$  rms current is approximately 4.25mA. Total power losses are:

$$\Sigma P_{\text{COND}} + P_{\text{SW}} + P_{\text{DIODE}} + P_{\text{IND}} + P_{\text{Q}} + P_{\text{BOOST}} = P_{\text{LOSS}}$$

#### Design Example 1:

Operating Conditions			
$V_{\text{IN}}$	5.0V	$P_{\text{OUT}}$	2.5W
$V_{\text{OUT}}$	2.5V	$P_{\text{DIODE}}$	151mW
$I_{\text{OUT}}$	1.0A	$P_{\text{IND}}$	75mW
$V_{\text{D}}$	0.35V	$P_{\text{SWF}}$	53mW
Freq	3MHz	$P_{\text{SWR}}$	53mW
$I_{\text{Q}}$	1.5mA	$P_{\text{COND}}$	187mW
$T_{\text{RISE}}$	8ns	$P_{\text{Q}}$	7.5mW
$T_{\text{FALL}}$	8ns	$P_{\text{BOOST}}$	21mW
$R_{\text{DS(ON)}}$	330m $\Omega$	$P_{\text{LOSS}}$	<b>548mW</b>
$\text{IND}_{\text{DCR}}$	75m $\Omega$		
D	<b>0.568</b>		

$$\eta = 82\%$$

## Calculating the LM2734Z Junction Temperature

Thermal Definitions:

$T_{\text{J}}$  = Chip junction temperature

$T_{\text{A}}$  = Ambient temperature

$R_{\theta\text{JC}}$  = Thermal resistance from chip junction to device case

$R_{\theta\text{JA}}$  = Thermal resistance from chip junction to ambient air

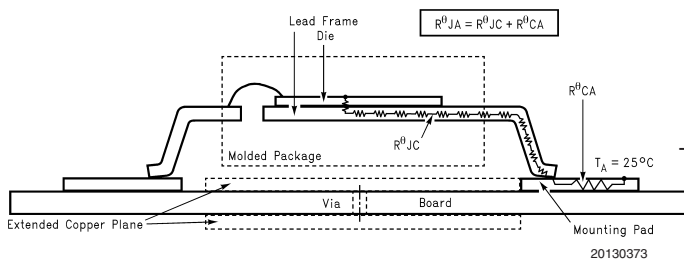

**FIGURE 6. Cross-Sectional View of Integrated Circuit Mounted on a Printed Circuit Board.**

Heat in the LM2734Z due to internal power dissipation is removed through conduction and/or convection.

**Conduction:** Heat transfer occurs through cross sectional areas of material. Depending on the material, the transfer of heat can be considered to have poor to good thermal conductivity properties (insulator vs conductor).

Heat Transfer goes as:

silicon → package → lead frame → PCB.

**Convection:** Heat transfer is by means of airflow. This could be from a fan or natural convection. Natural convection occurs when air currents rise from the hot device to cooler air.

Thermal impedance is defined as:

$$R_{\theta} = \frac{\Delta T}{\text{Power}}$$

Thermal impedance from the silicon junction to the ambient air is defined as:

$$R_{\theta\text{JA}} = \frac{T_{\text{J}} - T_{\text{A}}}{\text{Power}}$$

This impedance can vary depending on the thermal properties of the PCB. This includes PCB size, weight of copper used to route traces and ground plane, and number of layers within the PCB. The type and number of thermal vias can also make a large difference in the thermal impedance. Thermal vias are necessary in most applications. They conduct heat from the surface of the PCB to the ground plane. Four to six thermal vias should be placed under the exposed pad to the ground plane if the LLP package is used. If the Thin SOT23-6 package is used, place two to four thermal vias close to the ground pin of the device.

The datasheet specifies two different  $R_{\theta\text{JA}}$  numbers for the Thin SOT23-6 package. The two numbers show the difference in thermal impedance for a four-layer board with 2oz. copper traces, vs. a four-layer board with 1oz. copper.  $R_{\theta\text{JA}}$  equals 120°C/W for 2oz. copper traces and GND plane, and 235°C/W for 1oz. copper traces and GND plane.

Method 1:

To accurately measure the silicon temperature for a given application, two methods can be used. The first method requires the user to know the thermal impedance of the silicon junction to case. ( $R_{\theta\text{JC}}$ ) is approximately 80°C/W for the Thin SOT23-6 package. Knowing the internal dissipation from the efficiency calculation given previously, and the case temperature, which can be empirically measured on the bench we have:

$$R_{\theta\text{JA}} = \frac{T_{\text{J}} - T_{\text{C}}}{\text{Power}}$$

Therefore:

$$T_{\text{J}} = (R_{\theta\text{JC}} \times P_{\text{LOSS}}) + T_{\text{C}}$$

#### Design Example 2:

Operating Conditions			
$V_{\text{IN}}$	5.0V	$P_{\text{OUT}}$	2.5W
$V_{\text{OUT}}$	2.5V	$P_{\text{DIODE}}$	151mW
$I_{\text{OUT}}$	1.0A	$P_{\text{IND}}$	75mW
$V_{\text{D}}$	0.35V	$P_{\text{SWF}}$	53mW
Freq	3MHz	$P_{\text{SWR}}$	53mW
$I_{\text{Q}}$	1.5mA	$P_{\text{COND}}$	187mW
$T_{\text{RISE}}$	8ns	$P_{\text{Q}}$	7.5mW
$T_{\text{FALL}}$	8ns	$P_{\text{BOOST}}$	21mW
$R_{\text{DS(ON)}}$	330m $\Omega$	$P_{\text{LOSS}}$	<b>548mW</b>
$\text{IND}_{\text{DCR}}$	75m $\Omega$		
D	<b>0.568</b>		

## Calculating the LM2734Z Junction Temperature

李明"LM2734Z"供应商 (Continued)

$$\Sigma P_{\text{COND}} + P_{\text{SWF}} + P_{\text{SWR}} + P_{\text{Q}} + P_{\text{BOOST}} = P_{\text{INTERNAL}}$$

$$P_{\text{INTERNAL}} = 322 \text{ mW}$$

$$T_{\text{J}} = (R_{\theta\text{JC}} \times \text{Power}) + T_{\text{C}} = 80^{\circ}\text{C/W} \times 322 \text{ mW} + T_{\text{C}}$$

The second method can give a very accurate silicon junction temperature. The first step is to determine  $R_{\theta\text{JA}}$  of the application. The LM2734Z has over-temperature protection circuitry. When the silicon temperature reaches  $165^{\circ}\text{C}$ , the device stops switching. The protection circuitry has a hysteresis of  $15^{\circ}\text{C}$ . Once the silicon temperature has decreased to approximately  $150^{\circ}\text{C}$ , the device will start to switch again. Knowing this, the  $R_{\theta\text{JA}}$  for any PCB can be characterized during the early stages of the design by raising the ambient temperature in the given application until the circuit enters thermal shutdown. If the SW-pin is monitored, it will be obvious when the internal NFET stops switching indicating a junction temperature of  $165^{\circ}\text{C}$ . Knowing the internal power dissipation from the above methods, the junction temperature and the ambient temperature,  $R_{\theta\text{JA}}$  can be determined.

$$R_{\theta\text{JA}} = \frac{165^{\circ}\text{C} - T_{\text{A}}}{P_{\text{INTERNAL}}}$$

Once this is determined, the maximum ambient temperature allowed for a desired junction temperature can be found.

### Design Example 3:

#### Operating Conditions

Package	SOT23-6	
$V_{\text{IN}}$	12.0V	$P_{\text{OUT}}$ 2.475W
$V_{\text{OUT}}$	3.30V	$P_{\text{DIODE}}$ 523mW
$I_{\text{OUT}}$	750mA	$P_{\text{IND}}$ 56.25mW
$V_{\text{D}}$	0.35V	$P_{\text{SWF}}$ 108mW
Freq	3MHz	$P_{\text{SWR}}$ 108mW
$I_{\text{Q}}$	1.5mA	$P_{\text{COND}}$ 68.2mW
$I_{\text{BOOST}}$	4mA	$P_{\text{Q}}$ 18mW
$V_{\text{BOOST}}$	5V	$P_{\text{BOOST}}$ 20mW
$T_{\text{RISE}}$	8ns	$P_{\text{LOSS}}$ <b>902mW</b>
$T_{\text{FALL}}$	8ns	
$R_{\text{DSON}}$	400m $\Omega$	
$\text{IND}_{\text{DCR}}$	75m $\Omega$	
D	<b>30.3%</b>	

$$\Sigma P_{\text{COND}} + P_{\text{SWF}} + P_{\text{SWR}} + P_{\text{Q}} + P_{\text{BOOST}} = P_{\text{INTERNAL}}$$

$$P_{\text{INTERNAL}} = 322 \text{ mW}$$

Using a standard National Semiconductor Thin SOT23-6 demonstration board to determine the  $R_{\theta\text{JA}}$  of the board. The four layer PCB is constructed using FR4 with 1/2oz copper traces. The copper ground plane is on the bottom layer. The

ground plane is accessed by two vias. The board measures 2.5cm x 3cm. It was placed in an oven with no forced airflow. The ambient temperature was raised to  $94^{\circ}\text{C}$ , and at that temperature, the device went into thermal shutdown.

$$R_{\theta\text{JA}} = \frac{165^{\circ}\text{C} - 94^{\circ}\text{C}}{322 \text{ mW}} = 220^{\circ}\text{C/W}$$

If the junction temperature was to be kept below  $125^{\circ}\text{C}$ , then the ambient temperature cannot go above  $54.2^{\circ}\text{C}$ .

$$T_{\text{J}} - (R_{\theta\text{JA}} \times P_{\text{LOSS}}) = T_{\text{A}}$$

The method described above to find the junction temperature in the Thin SOT23-6 package can also be used to calculate the junction temperature in the LLP package. The 6 pin LLP package has a  $R_{\theta\text{JC}} = 20^{\circ}\text{C/W}$ , and  $R_{\theta\text{JA}}$  can vary depending on the application.  $R_{\theta\text{JA}}$  can be calculated in the same manner as described in method #2 (see example 3).

## LLP Package

The LM2734Z is packaged in a Thin SOT23-6 package and the 6-pin LLP. The LLP package has the same footprint as the Thin SOT23-6, but is thermally superior due to the exposed ground paddle on the bottom of the package.

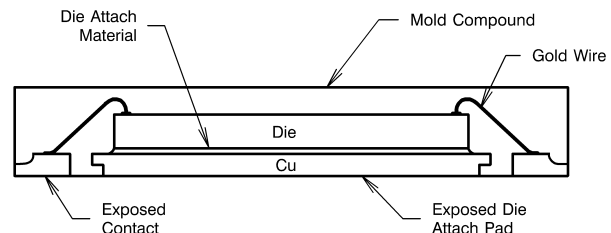

20130374

### No Pullback LLP Configuration

$R_{\theta\text{JA}}$  of the LLP package is normally two to three times better than that of the Thin SOT23-6 package for a similar PCB configuration (area, copper weight, thermal vias).

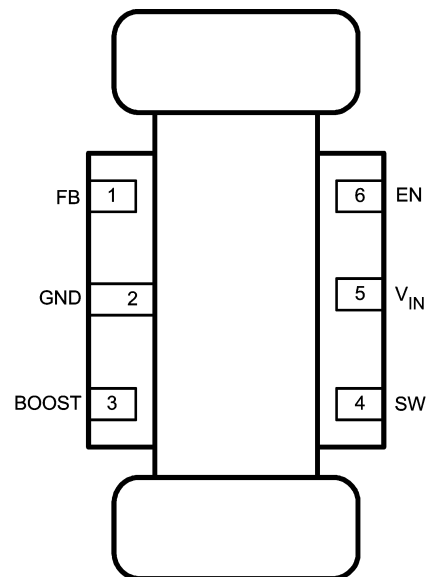

20130370

FIGURE 7. Dog Bone

## LLP Package (Continued)

For certain high power applications, the PCB land may be modified to a "dog bone" shape (see *Figure 7*). By increasing the size of ground plane, and adding thermal vias, the  $R_{\theta JA}$  for the application can be reduced.

### Design Example 4:

#### Operating Conditions

Package	LLP-6		
$V_{IN}$	12.0V	$P_{OUT}$	2.475W
$V_{OUT}$	3.3V	$P_{DIODE}$	523mW
$I_{OUT}$	750mA	$P_{IND}$	56.25mW
$V_D$	0.35V	$P_{SWF}$	108mW
Freq	3MHz	$P_{SWR}$	108mW
$I_Q$	1.5mA	$P_{COND}$	68.2mW
$I_{BOOST}$	4mA	$P_Q$	18mW
$V_{BOOST}$	5V	$P_{BOOST}$	20mW
$T_{RISE}$	8ns	$P_{LOSS}$	<b>902mW</b>
$T_{FALL}$	8ns		
$R_{DSON}$	400m $\Omega$		
$IND_{DCR}$	75m $\Omega$		
D	<b>30.3%</b>		

$$\Sigma P_{COND} + P_{SWF} + P_{SWR} + P_Q + P_{BOOST} = P_{INTERNAL}$$

$$P_{INTERNAL} = \mathbf{322\ mW}$$

This example follows example 2, but uses the LLP package. Using a standard National Semiconductor LLP-6 demonstration board, use Method 2 to determine  $R_{\theta JA}$  of the board. The four layer PCB is constructed using FR4 with 1/2oz copper traces. The copper ground plane is on the bottom layer. The ground plane is accessed by four vias. The board measures 2.5cm x 3cm. It was placed in an oven with no forced airflow.

The ambient temperature was raised to 113°C, and at that temperature, the device went into thermal shutdown.

$$R_{\theta JA} = \frac{165^\circ\text{C} - 113^\circ\text{C}}{322\ \text{mW}} = 161^\circ\text{C/W}$$

If the junction temperature is to be kept below 125°C, then the ambient temperature cannot go above 73.2°C.

$$T_J - (R_{\theta JA} \times P_{LOSS}) = T_A$$

## Package Selection

To determine which package you should use for your specific application, variables need to be known before you can determine the appropriate package to use.

1. Maximum ambient system temperature
2. Internal LM2734Z power losses
3. Maximum junction temperature desired
4.  $R_{\theta JA}$  of the specific application, or  $R_{\theta JC}$  (LLP or Thin SOT23-6)

The junction temperature must be less than 125°C for the worst-case scenario.

## LM2734Z Design Examples

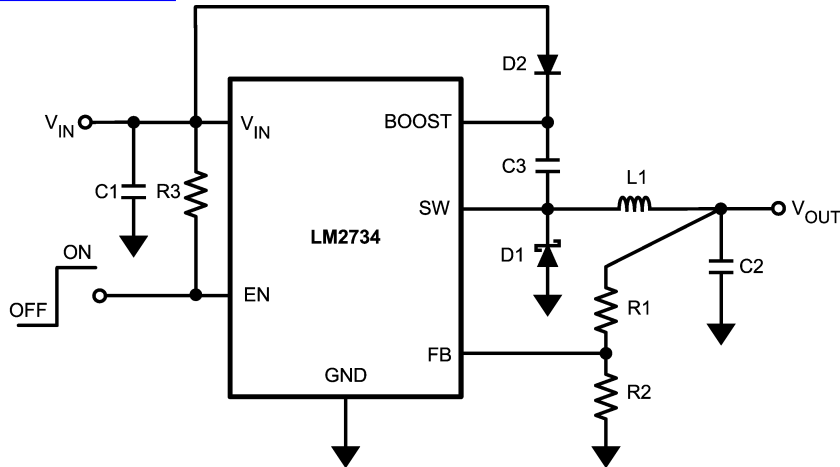
[查询"LM2734ZMK"供应商](#)

20130342

**FIGURE 8.  $V_{BOOST}$  Derived from  $V_{IN}$**   
**Operating Conditions: 5V to 1.5V/1A**

## Bill of Materials for Figure 8

Part ID	Part Value	Part Number	Manufacturer
U1	1A Buck Regulator	LM2734ZX	National Semiconductor
C1, Input Cap	10 $\mu$ F, 6.3V, X5R	C3216X5ROJ106M	TDK
C2, Output Cap	10 $\mu$ F, 6.3V, X5R	C3216X5ROJ106M	TDK
C3, Boost Cap	0.01 $\mu$ F, 16V, X7R	C1005X7R1C103K	TDK
D1, Catch Diode	0.3V <sub>F</sub> Schottky 1A, 10VR	MBRM110L	ON Semi
D2, Boost Diode	1V <sub>F</sub> @ 50mA Diode	1N4148W	Diodes, Inc.
L1	2.2 $\mu$ H, 1.8A	ME3220-222MX	Coilcraft
R1	8.87k $\Omega$ , 1%	CRCW06038871F	Vishay
R2	10.2k $\Omega$ , 1%	CRCW06031022F	Vishay
R3	100k $\Omega$ , 1%	CRCW06031003F	Vishay

## LM2734Z Design Examples (Continued)

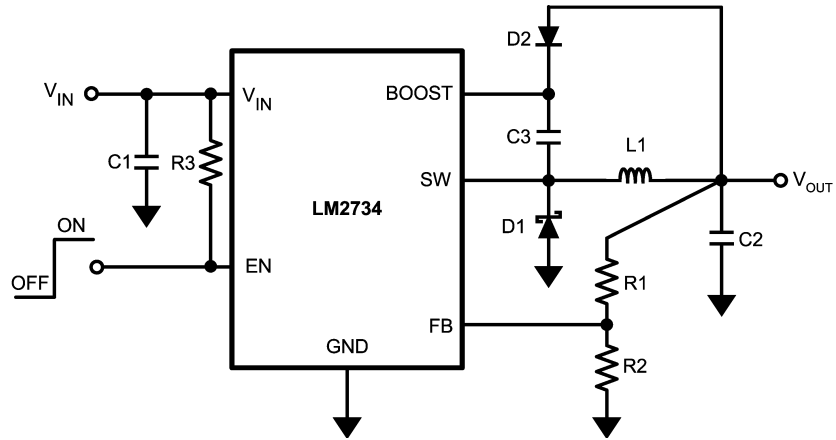
[查询"LM2734ZMK"供应商](#)

20130343

FIGURE 9.  $V_{BOOST}$  Derived from  $V_{OUT}$   
12V to 3.3V/1A

## Bill of Materials for Figure 9

Part ID	Part Value	Part Number	Manufacturer
U1	1A Buck Regulator	LM2734ZX	National Semiconductor
C1, Input Cap	10µF, 25V, X7R	C3225X7R1E106M	TDK
C2, Output Cap	22µF, 6.3V, X5R	C3216X5ROJ226M	TDK
C3, Boost Cap	0.01µF, 16V, X7R	C1005X7R1C103K	TDK
D1, Catch Diode	0.34V <sub>F</sub> Schottky 1A, 30VR	SS1P3L	Vishay
D2, Boost Diode	0.6V <sub>F</sub> @ 30mA Diode	BAT17	Vishay
L1	3.3µH, 1.3A	ME3220-332MX	Coilcraft
R1	31.6kΩ, 1%	CRCW06033162F	Vishay
R2	10.0 kΩ, 1%	CRCW06031002F	Vishay
R3	100kΩ, 1%	CRCW06031003F	Vishay

## LM2734Z Design Examples (Continued)

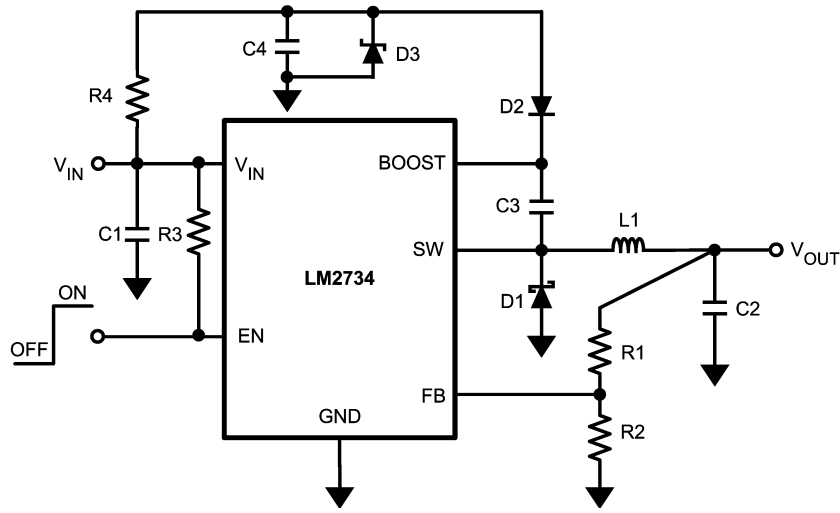
[查询"LM2734ZMK"供应商](#)

20130344

FIGURE 10.  $V_{BOOST}$  Derived from  $V_{SHUNT}$   
18V to 1.5V/1A

## Bill of Materials for Figure 10

Part ID	Part Value	Part Number	Manufacturer
U1	1A Buck Regulator	LM2734ZX	National Semiconductor
C1, Input Cap	10 $\mu$ F, 25V, X7R	C3225X7R1E106M	TDK
C2, Output Cap	22 $\mu$ F, 6.3V, X5R	C3216X5ROJ226M	TDK
C3, Boost Cap	0.01 $\mu$ F, 16V, X7R	C1005X7R1C103K	TDK
C4, Shunt Cap	0.1 $\mu$ F, 6.3V, X5R	C1005X5R0J104K	TDK
D1, Catch Diode	0.4V <sub>F</sub> Schottky 1A, 30V <sub>R</sub>	SS1P3L	Vishay
D2, Boost Diode	1V <sub>F</sub> @ 50mA Diode	1N4148W	Diodes, Inc.
D3, Zener Diode	5.1V 250Mw SOT-23	BZX84C5V1	Vishay
L1	3.3 $\mu$ H, 1.3A	ME3220-332MX	Coilcraft
R1	8.87k $\Omega$ , 1%	CRCW06038871F	Vishay
R2	10.2k $\Omega$ , 1%	CRCW06031022F	Vishay
R3	100k $\Omega$ , 1%	CRCW06031003F	Vishay
R4	4.12k $\Omega$ , 1%	CRCW06034121F	Vishay

## LM2734Z Design Examples (Continued)

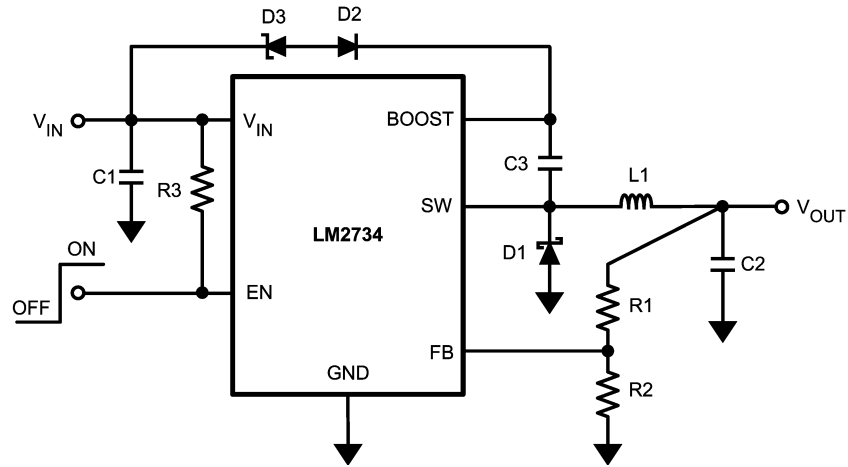
[查询"LM2734ZMK"供应商](#)

20130349

FIGURE 11.  $V_{BOOST}$  Derived from Series Zener Diode ( $V_{IN}$ )  
15V to 1.5V/1A

## Bill of Materials for Figure 11

Part ID	Part Value	Part Number	Manufacturer
U1	1A Buck Regulator	LM2734ZX	National Semiconductor
C1, Input Cap	10 $\mu$ F, 25V, X7R	C3225X7R1E106M	TDK
C2, Output Cap	22 $\mu$ F, 6.3V, X5R	C3216X5ROJ226M	TDK
C3, Boost Cap	0.01 $\mu$ F, 16V, X7R	C1005X7R1C103K	TDK
D1, Catch Diode	0.4V <sub>F</sub> Schottky 1A, 30VR	SS1P3L	Vishay
D2, Boost Diode	1V <sub>F</sub> @ 50mA Diode	1N4148W	Diodes, Inc.
D3, Zener Diode	11V 350Mw SOT-23	BZX84C11T	Diodes, Inc.
L1	3.3 $\mu$ H, 1.3A	ME3220-332MX	Coilcraft
R1	8.87k $\Omega$ , 1%	CRCW06038871F	Vishay
R2	10.2k $\Omega$ , 1%	CRCW06031022F	Vishay
R3	100k $\Omega$ , 1%	CRCW06031003F	Vishay

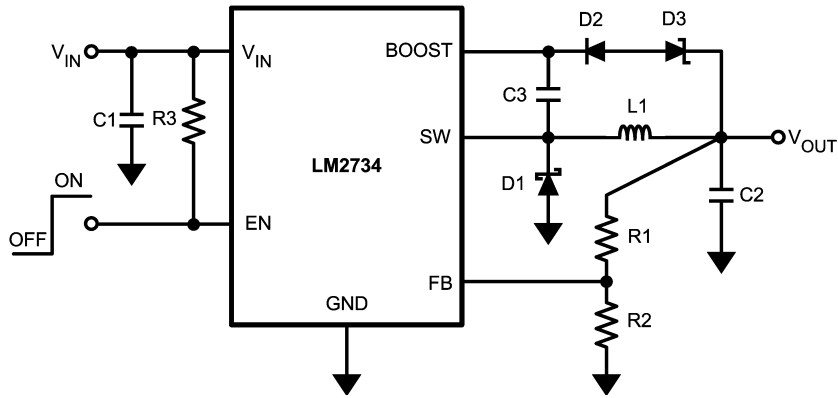

## LM2734Z Design Examples (Continued)

[查询"LM2734ZMK"供应商](#)

20130350

FIGURE 12.  $V_{BOOST}$  Derived from Series Zener Diode ( $V_{OUT}$ )  
15V to 9V/1A

## Bill of Materials for Figure 12

Part ID	Part Value	Part Number	Manufacturer
U1	1A Buck Regulator	LM2734ZX	National Semiconductor
C1, Input Cap	10µF, 25V, X7R	C3225X7R1E106M	TDK
C2, Output Cap	22µF, 16V, X5R	C3216X5R1C226M	TDK
C3, Boost Cap	0.01µF, 16V, X7R	C1005X7R1C103K	TDK
D1, Catch Diode	0.4V <sub>F</sub> Schottky 1A, 30VR	SS1P3L	Vishay
D2, Boost Diode	1V <sub>F</sub> @ 50mA Diode	1N4148W	Diodes, Inc.
D3, Zener Diode	4.3V 350mw SOT-23	BZX84C4V3	Diodes, Inc.
L1	2.2µH, 1.8A	ME3220-222MX	Coilcraft
R1	102kΩ, 1%	CRCW06031023F	Vishay
R2	10.2kΩ, 1%	CRCW06031022F	Vishay
R3	100kΩ, 1%	CRCW06031003F	Vishay

**Physical Dimensions** inches (millimeters) unless otherwise noted

请向"LM2734ZMK"供应商

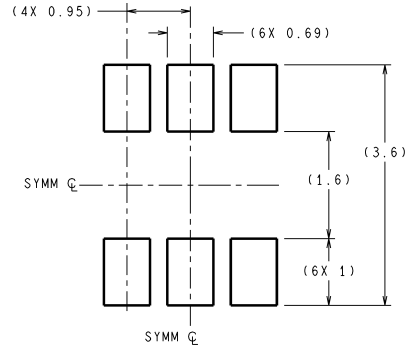
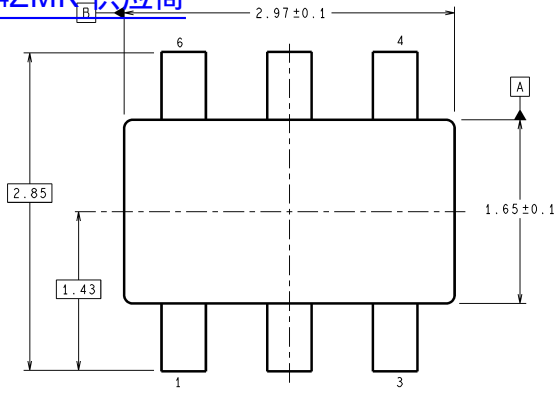

RECOMMENDED LAND PATTERN

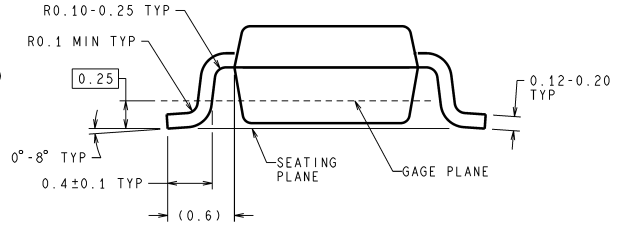
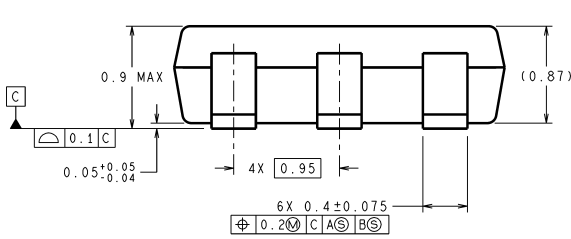

DIMENSIONS ARE IN MILLIMETERS

MK06A (Rev C)

**6-Lead SOT23 Package**  
**NS Package Number MK06A**

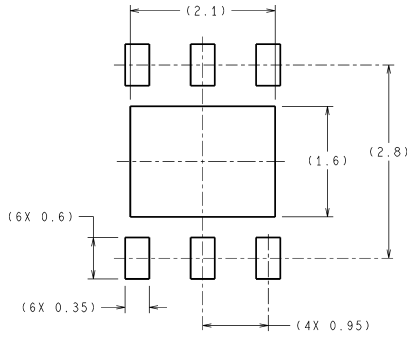

RECOMMENDED LAND PATTERN

DIMENSIONS ARE IN MILLIMETERS  
DIMENSION IN ( ) FOR REFERENCE ONLY

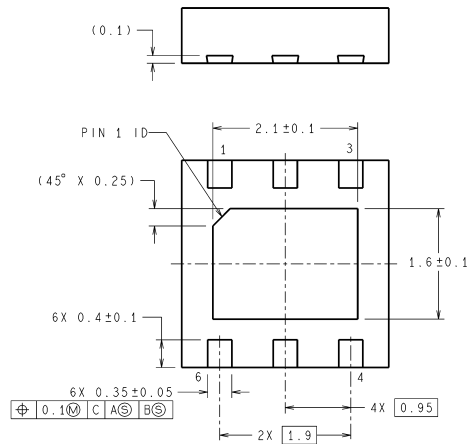
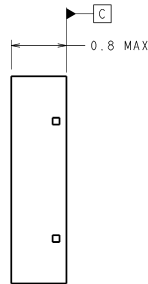
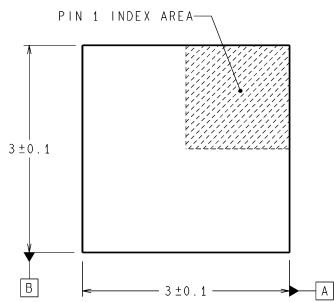

SDE06A (Rev A)

**6-Lead LLP Package**  
**NS Package Number SDE06A**

## Notes

[查询"LM2734ZMK"供应商](#)

National does not assume any responsibility for use of any circuitry described, no circuit patent licenses are implied and National reserves the right at any time without notice to change said circuitry and specifications.

For the most current product information visit us at [www.national.com](http://www.national.com).

### LIFE SUPPORT POLICY

NATIONAL'S PRODUCTS ARE NOT AUTHORIZED FOR USE AS CRITICAL COMPONENTS IN LIFE SUPPORT DEVICES OR SYSTEMS WITHOUT THE EXPRESS WRITTEN APPROVAL OF THE PRESIDENT AND GENERAL COUNSEL OF NATIONAL SEMICONDUCTOR CORPORATION. As used herein:

- |  |   |
|--|---|
| <p>1. Life support devices or systems are devices or systems which, (a) are intended for surgical implant into the body, or (b) support or sustain life, and whose failure to perform when properly used in accordance with instructions for use provided in the labeling, can be reasonably expected to result in a significant injury to the user.</p> | <p>2. A critical component is any component of a life support device or system whose failure to perform can be reasonably expected to cause the failure of the life support device or system, or to affect its safety or effectiveness.</p> |
|--|---|

### BANNED SUBSTANCE COMPLIANCE

National Semiconductor manufactures products and uses packing materials that meet the provisions of the Customer Products Stewardship Specification (CSP-9-111C2) and the Banned Substances and Materials of Interest Specification (CSP-9-111S2) and contain no "Banned Substances" as defined in CSP-9-111S2.



**National Semiconductor**  
**Americas Customer**  
**Support Center**  
 Email: [new.feedback@nsc.com](mailto:new.feedback@nsc.com)  
 Tel: 1-800-272-9959

**National Semiconductor**  
**Europe Customer Support Center**  
 Fax: +49 (0) 180-530 85 86  
 Email: [europa.support@nsc.com](mailto:europa.support@nsc.com)  
 Deutsch Tel: +49 (0) 69 9508 6208  
 English Tel: +44 (0) 870 24 0 2171  
 Français Tel: +33 (0) 1 41 91 8790

**National Semiconductor**  
**Asia Pacific Customer**  
**Support Center**  
 Email: [ap.support@nsc.com](mailto:ap.support@nsc.com)

**National Semiconductor**  
**Japan Customer Support Center**  
 Fax: 81-3-5639-7507  
 Email: [jpn.feedback@nsc.com](mailto:jpn.feedback@nsc.com)  
 Tel: 81-3-5639-7560