

16-Bit 250-kSPS Sampling CMOS ANALOG-TO-DIGITAL CONVERTER

Check for Samples: [ADS8515](#)

FEATURES

- Standard $\pm 10\text{-V}$ Input Range
- 90-dB Min SNR with 20-kHz Input
- ± 2.0 LSB Max INL
- ± 1 LSB Max DNL, 16 Bits, No Missing Code
- 5-V Analog Supply, Flexible I/O Supply Voltage at 1.65 V to 5.25 V
- Pin-Compatible with ADS7805/10 (Low Speed), and 12-Bit ADS7804/8504
- Uses Internal or External Reference
- Full Parallel Data Output
- 100-mW Typ Power Dissipation at 250 kSPS
- 28-Pin SSOP Package

APPLICATIONS

- Industrial Process Control
- Data Acquisition Systems
- Digital Signal Processing
- Medical Equipment
- Instrumentation

DESCRIPTION

The ADS8515 is a complete 16-bit sampling analog-to-digital (A/D) converter using state-of-the-art CMOS structures. It contains a complete 16-bit, capacitor-based, SAR A/D converter with sample and hold (S/H), reference, clock, interface for microprocessor use, and 3-state output drivers.

The ADS8515 is specified at a 250-kHz sampling rate over the full temperature range. Precision resistors provide an industry standard $\pm 10\text{-V}$ input range, while the innovative design allows operation from a single $+5\text{-V}$ supply, with power dissipation under 100 mW.

The ADS8515 is available in a 28-pin SSOP package and is fully specified for operation over the industrial -40°C to 85°C temperature range.

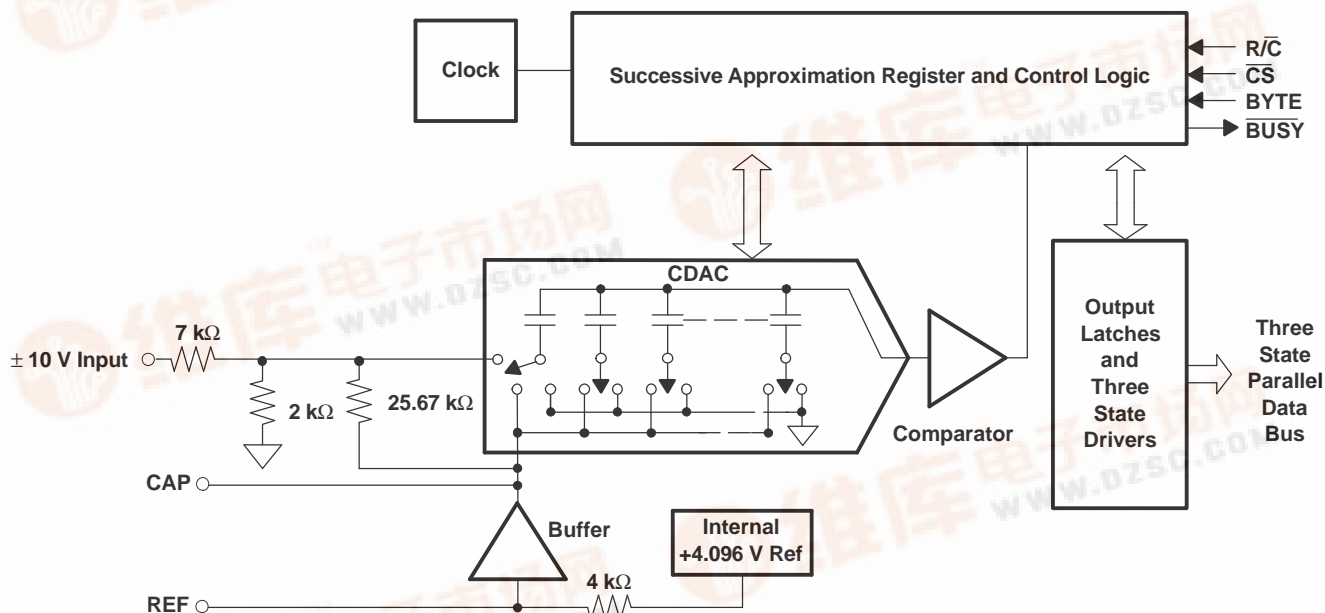

Please be aware that an important notice concerning availability, standard warranty, and use in critical applications of Texas Instruments semiconductor products and disclaimers thereto appears at the end of this data sheet.

All trademarks are the property of their respective owners.

PRODUCTION DATA information is current as of publication date. Products conform to specifications per the terms of the Texas Instruments standard warranty. Production processing does not necessarily include testing of all parameters.

Copyright © 2007–2010, Texas Instruments Incorporated



[查询ADS8515 供应商](#)



This integrated circuit can be damaged by ESD. Texas Instruments recommends that all integrated circuits be handled with appropriate precautions. Failure to observe proper handling and installation procedures can cause damage.

ESD damage can range from subtle performance degradation to complete device failure. Precision integrated circuits may be more susceptible to damage because very small parametric changes could cause the device not to meet its published specifications.

PACKAGE/ORDERING INFORMATION⁽¹⁾

PRODUCT	MINIMUM INL (LSB)	NO MISSING CODE	MINIMUM SINAD (dB)	SPECIFIED TEMPERATURE RANGE	PACKAGE-LEAD	PACKAGE DESIGNATOR	ORDERING NUMBER	TRANSPORT MEDIA, QTY
ADS8515B	±2	16 Bits	89	−40°C to 85°C	SSOP-28	DB	ADS8515IBDB	Tube, 50
							ADS8515IBDBR	Tape and Reel, 2000
ADS8515I	±3	16 Bits	87	−40°C to 85°C	SSOP-28	DB	ADS8515IDB	Tube, 50
							ADS8515IDBR	Tape and Reel, 2000

(1) For the most current package and ordering information, see the Package Option Addendum at the end of this document, or see the [ADS8515 product folder](#) at www.ti.com.

ABSOLUTE MAXIMUM RATINGS⁽¹⁾⁽²⁾

Over operating free-air temperature range (unless otherwise noted)

		ADS8515
Analog inputs	V _{IN}	±25V
	CAP	+V _{ANA} + 0.3 V to AGND2 − 0.3 V
	REF	Indefinite short to AGND2, momentary short to V _{ANA}
Ground voltage differences	DGND, AGND1, AGND2	±0.3 V
	V _{ANA}	6 V
	V _{DIG}	6 V
Digital inputs		−0.3 V to +V _{DIG} + 0.3 V
Maximum junction temperature		165°C
Internal power dissipation		825 mW

(1) Stresses beyond those listed under *Absolute Maximum Ratings* may cause permanent damage to the device. These are stress ratings only, and functional operation of the device at these or any other conditions beyond those indicated under *Recommended Operating Conditions* is not implied. Exposure to absolute-maximum-rated conditions for extended periods may affect device reliability.

(2) All voltage values are with respect to network ground terminal.

ELECTRICAL CHARACTERISTICS

At $T_A = -40^\circ\text{C}$ to 85°C , $f_s = 250\text{ kHz}$, $V_{\text{DIG}} = V_{\text{ANA}} = 5\text{ V}$, and using internal reference (unless otherwise noted).

PARAMETER	TEST CONDITIONS	ADS8515I			ADS8515IB			UNIT	
		MIN	TYP	MAX	MIN	TYP	MAX		
Resolution				16			16	Bits	
ANALOG INPUT									
Voltage range			± 10		± 10			V	
Impedance			8.885		8.885			k Ω	
Capacitance			75		75			pF	
THROUGHPUT SPEED									
Conversion cycle time	Acquire and convert			4			4	μs	
Throughput rate		250			250			kHz	
DC ACCURACY									
INL	Integral linearity error		-3	3	-2		2	LSB ⁽¹⁾	
DNL	Differential linearity error		-1	2	-1		1	LSB ⁽¹⁾	
	No missing codes		16		16			Bits	
	Transition noise ⁽²⁾		0.67		0.67			LSB	
	Full-scale error ^{(3) (4)}	Int. Ref.	-0.5	0.5	-0.25		0.25	%FSR	
	Full-scale error drift	Int. Ref.		± 7			± 7	ppm/ $^\circ\text{C}$	
	Full-scale error ^{(3) (4)}	Ext. 4.096-V Ref.	-0.25	0.25	-0.1		0.1	%FSR	
	Full-scale error drift	Ext. 4.096-V Ref.		± 2			± 2	ppm/ $^\circ\text{C}$	
	Bipolar zero error ⁽³⁾		-4	4	-2		2	mV	
	Bipolar zero error drift			± 2			± 2	ppm/ $^\circ\text{C}$	
	Power supply sensitivity ($V_{\text{DIG}} = V_{\text{ANA}} = V_{\text{D}}$)	+4.75 V < V_{D} < +5.25 V	-8	8	-8		8	LSB	
AC ACCURACY									
SFDR	Spurious-free dynamic range	$f_i = 20\text{ kHz}$	95	102	97	102		dB ⁽⁵⁾	
THD	Total harmonic distortion	$f_i = 20\text{ kHz}$		-100	-94		-100	dB	
SINAD	Signal-to-(noise+distortion)	$f_i = 20\text{ kHz}$	87	91	89	91		dB	
		-60-dB Input		30		32		dB	
SNR	Signal-to-noise ratio	$f_i = 20\text{ kHz}$	88	92	90	92		dB	
	Full-power bandwidth ⁽⁶⁾			500		500		kHz	
SAMPLING DYNAMICS									
	Aperture delay			5		5		ns	
	Transient response	FS Step		2		2		μs	
	Overvoltage recovery ⁽⁷⁾			150		150		ns	
REFERENCE									
	Internal reference voltage		4.076	4.096	4.116	4.076	4.096	4.116	V
	Internal reference source current (must use external buffer)			1		1		μA	
	Internal reference drift			8		8		ppm/ $^\circ\text{C}$	
	External reference voltage range for specified linearity		3.9	4.096	4.2	3.9	4.096	4.2	V
	External reference current drain	Ext. 4.096-V Ref.			100			100	μA
DIGITAL INPUTS									
	Logic levels								
V_{IL}	Low-level input voltage	$V_{\text{DIG}} = 1.65\text{ V} - 5.25\text{ V}$	-0.3		0.8	-0.3		$0.35 \cdot V_{\text{DIG}}$	V
V_{IH}	High-level input voltage	$V_{\text{DIG}} = 1.65\text{ V} - 5.25\text{ V}$	$0.65 \cdot V_{\text{DIG}}$		$V_{\text{DIG}} + 0.3\text{ V}$	$0.65 \cdot V_{\text{DIG}}$		$V_{\text{DIG}} + 0.3\text{ V}$	V
I_{IL}	Low-level input current	$V_{\text{IL}} = 0\text{ V}$			± 10			± 10	μA
I_{IH}	High-level input current	$V_{\text{IH}} = 5\text{ V}$			± 10			± 10	μA
DIGITAL OUTPUTS									

- (1) LSB means least significant bit. For the 16-bit, $\pm 10\text{-V}$ input ADS8515, one LSB is 305 μV .
- (2) Typical rms noise at worst case transitions and temperatures.
- (3) As measured with fixed resistors shown in Figure 22. Adjustable to zero with external potentiometer.
- (4) Full-scale error is the worst case of -full-scale or +full-scale deviation from ideal first and last code transitions, divided by the transition voltage (not divided by the full-scale range) and includes the effect of offset error.
- (5) All specifications in dB are referred to a full-scale $\pm 10\text{-V}$ input.
- (6) Full-power bandwidth is defined as the full-scale input frequency at which signal-to-(noise + distortion) degrades to 60 dB, or 10 bits of accuracy.
- (7) Recovers to specified performance after 2 x FS input overvoltage.

ELECTRICAL CHARACTERISTICS (continued)

At $T_A = -40^\circ\text{C}$ to 85°C , $f_s = 250\text{ kHz}$, $V_{\text{DIG}} = V_{\text{ANA}} = 5\text{ V}$, and using internal reference (unless otherwise noted).

PARAMETER	TEST CONDITIONS	ADS8515I			ADS8515IB			UNIT
		MIN	TYP	MAX	MIN	TYP	MAX	
Data format (parallel 16 bits)								
Data coding (binary twos complement)								
V_{OL}	Low-level output voltage $I_{\text{SINK}} = 1.6\text{ mA}$			0.4			0.4	V
V_{OH}	High-level output voltage $I_{\text{SOURCE}} = 500\ \mu\text{A}$	$0.8 \times V_{\text{DIG}}$			$0.8 \times V_{\text{DIG}}$			V
Leakage current	Hi-Z state, $V_{\text{OUT}} = 0\text{ V}$ to V_{DIG}			± 5			± 5	μA
Output capacitance	Hi-Z state			15			15	pF
DIGITAL TIMING								
Bus access timing				83			83	ns
Bus relinquish timing				83			83	ns
POWER SUPPLIES								
V_{DIG}	Digital input voltage	1.65		5.25	1.65		5.25	V
V_{ANA}	Analog input voltage	4.75	5	5.25	4.75	5	5.25	V
I_{DIG}	Digital input current		0.1	1		0.1	1	mA
I_{ANA}	Analog input current		20	25		20	25	mA
Power dissipation	$f_s = 250\text{ kHz}$		100	125		100	125	mW
TEMPERATURE RANGE								
Specified performance		-40		+85	-40		+85	$^\circ\text{C}$
Derated performance ⁽⁸⁾		-55		+125	-55		+125	$^\circ\text{C}$
Storage		-65		+150	-65		+150	$^\circ\text{C}$
THERMAL RESISTANCE (θ_{JA})								
SSOP			67			67		$^\circ\text{C/W}$

(8) The internal reference may not be started correctly beyond the industrial temperature range (-40°C to $+85^\circ\text{C}$); therefore, use of an external reference is recommended.

PIN CONFIGURATION

**DB PACKAGE
SSOP-28
(TOP VIEW)**

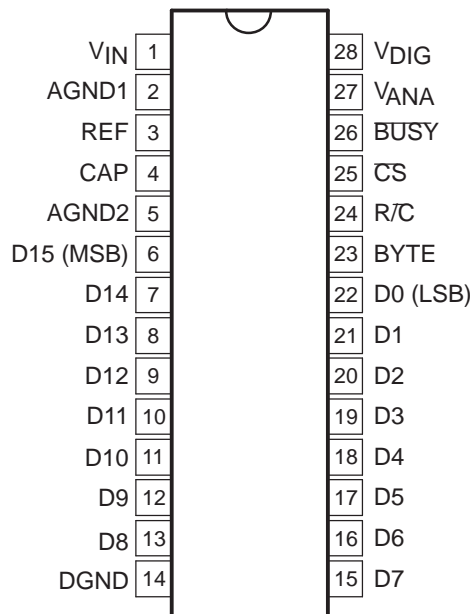

PIN DESCRIPTIONS

PIN		DIGITAL I/O	DESCRIPTION
NAME	NO.		
AGND1	2		Analog ground. Used internally as ground reference point.
AGND2	5		Analog ground.
$\overline{\text{BUSY}}$	26	O	At the start of a conversion, $\overline{\text{BUSY}}$ goes low and stays low until the conversion is completed and the digital outputs have been updated.
BYTE	23	I	Selects 8 most significant bits (low) or 8 least significant bits (high).
CAP	4		Reference buffer capacitor. 2.2- μF tantalum capacitor to ground.
$\overline{\text{CS}}$	25	I	Internally ORed with $\text{R}/\overline{\text{C}}$. If $\text{R}/\overline{\text{C}}$ low, a falling edge on $\overline{\text{CS}}$ initiates a new conversion.
DGND	14		Digital ground.
D15 (MSB)	6	O	Data bit 15. Most significant bit (MSB) of conversion results. Hi-Z state when $\overline{\text{CS}}$ is high, or when $\text{R}/\overline{\text{C}}$ is low.
D14	7	O	Data bit 14. Hi-Z state when $\overline{\text{CS}}$ is high, or when $\text{R}/\overline{\text{C}}$ is low.
D13	8	O	Data bit 13. Hi-Z state when $\overline{\text{CS}}$ is high, or when $\text{R}/\overline{\text{C}}$ is low.
D12	9	O	Data bit 12. Hi-Z state when $\overline{\text{CS}}$ is high, or when $\text{R}/\overline{\text{C}}$ is low.
D11	10	O	Data bit 11. Hi-Z state when $\overline{\text{CS}}$ is high, or when $\text{R}/\overline{\text{C}}$ is low.
D10	11	O	Data bit 10. Hi-Z state when $\overline{\text{CS}}$ is high, or when $\text{R}/\overline{\text{C}}$ is low.
D9	12	O	Data bit 9. Hi-Z state when $\overline{\text{CS}}$ is high, or when $\text{R}/\overline{\text{C}}$ is low.
D8	13	O	Data bit 8. Hi-Z state when $\overline{\text{CS}}$ is high, or when $\text{R}/\overline{\text{C}}$ is low.
D7	15	O	Data bit 7. Hi-Z state when $\overline{\text{CS}}$ is high, or when $\text{R}/\overline{\text{C}}$ is low.
D6	16	O	Data bit 6. Hi-Z state when $\overline{\text{CS}}$ is high, or when $\text{R}/\overline{\text{C}}$ is low.
D5	17	O	Data bit 5. Hi-Z state when $\overline{\text{CS}}$ is high, or when $\text{R}/\overline{\text{C}}$ is low.
D4	18	O	Data bit 4. Hi-Z state when $\overline{\text{CS}}$ is high, or when $\text{R}/\overline{\text{C}}$ is low.
D3	19	O	Data bit 3. Hi-Z state when $\overline{\text{CS}}$ is high, or when $\text{R}/\overline{\text{C}}$ is low.
D2	20	O	Data bit 2. Hi-Z state when $\overline{\text{CS}}$ is high, or when $\text{R}/\overline{\text{C}}$ is low.
D1	21	O	Data bit 1. Hi-Z state when $\overline{\text{CS}}$ is high, or when $\text{R}/\overline{\text{C}}$ is low.
D0 (LSB)	22	O	Data bit 0. Least significant bit (LSB) of conversion results. Hi-Z state when $\overline{\text{CS}}$ is high, or when $\text{R}/\overline{\text{C}}$ is low.
$\text{R}/\overline{\text{C}}$	24	I	With $\overline{\text{CS}}$ low and $\overline{\text{BUSY}}$ high, a falling edge on $\text{R}/\overline{\text{C}}$ initiates a new conversion. With $\overline{\text{CS}}$ low, a rising edge on $\text{R}/\overline{\text{C}}$ enables the parallel output.
REF	3		Reference input/output. 2.2- μF tantalum capacitor to ground.
V_{ANA}	27		Analog supply input. Nominally +5 V. Decouple to ground with 0.1- μF ceramic and 10- μF tantalum capacitors.
V_{DIG}	28		Digital supply input. Can be connected directly to pin 27.
V_{IN}	1		Analog input. See Figure 24 .

TYPICAL CHARACTERISTICS

TOTAL HARMONIC DISTORTION
VS
INPUT FREQUENCY

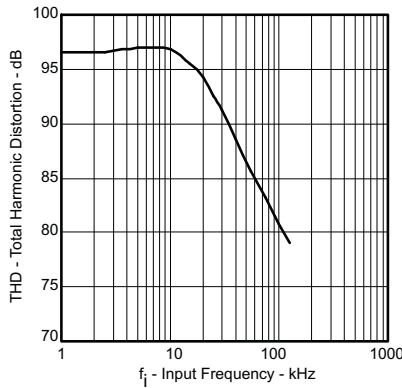

Figure 1.

SIGNAL-TO-NOISE RATIO
VS
INPUT FREQUENCY

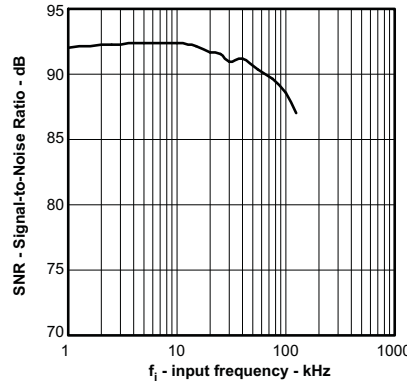

Figure 2.

SIGNAL-TO-NOISE AND
DISTORTION
VS
INPUT FREQUENCY

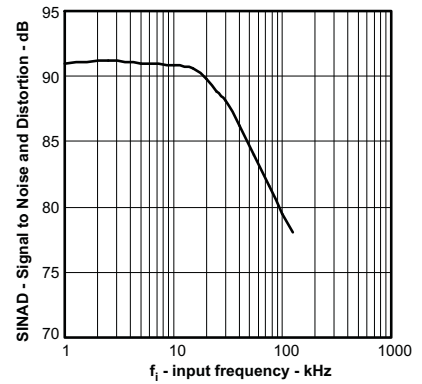

Figure 3.

SPURIOUS FREE DYNAMIC RANGE
VS
INPUT FREQUENCY

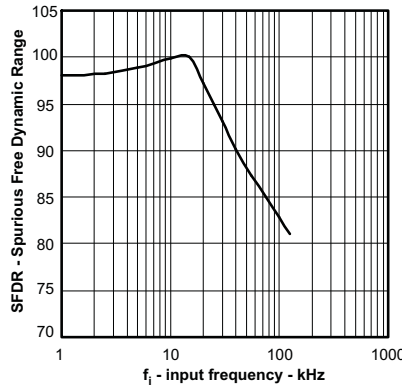

Figure 4.

SIGNAL-TO-NOISE RATIO
VS
FREE-AIR TEMPERATURE

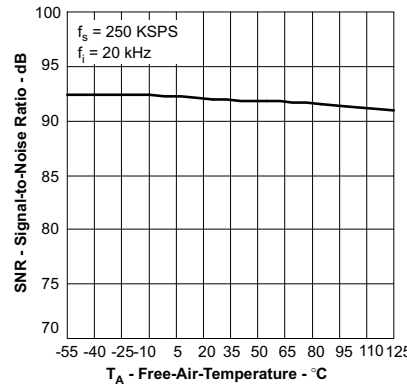

Figure 5.

SIGNAL-TO-NOISE AND
DISTORTION
VS
FREE-AIR TEMPERATURE

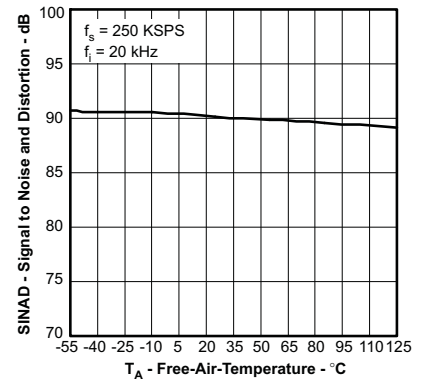

Figure 6.

SPURIOUS FREE DYNAMIC RANGE
VS
FREE-AIR TEMPERATURE

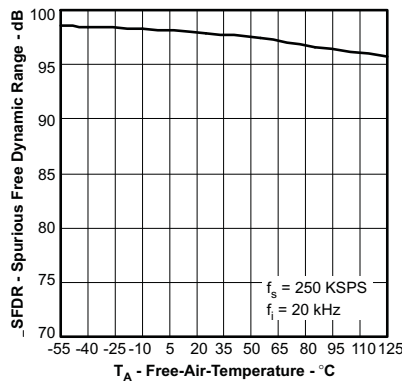

Figure 7.

TOTAL HARMONIC DISTORTION
VS
FREE-AIR TEMPERATURE

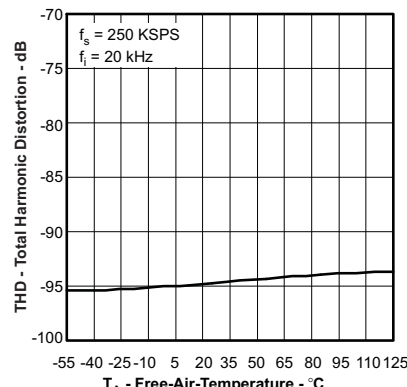

Figure 8.

INTERNAL REFERENCE VOLTAGE
VS
FREE-AIR TEMPERATURE

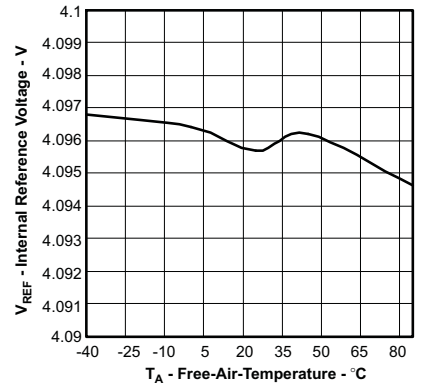

Figure 9.

TYPICAL CHARACTERISTICS (continued)

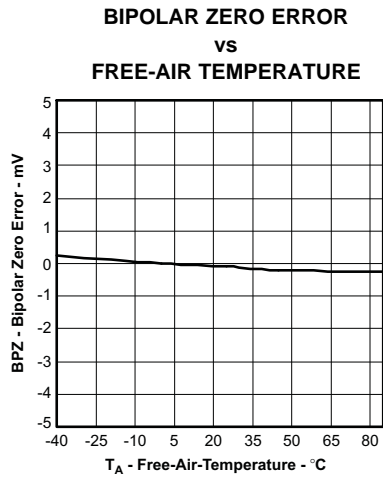

Figure 10.

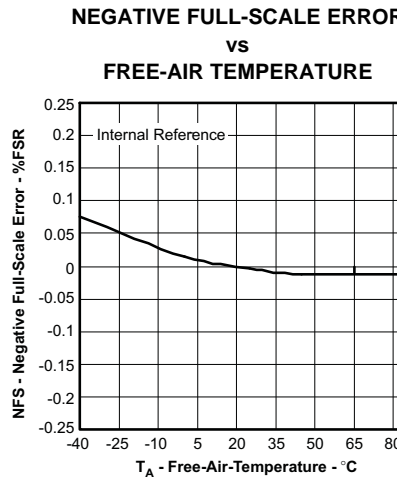

Figure 11.

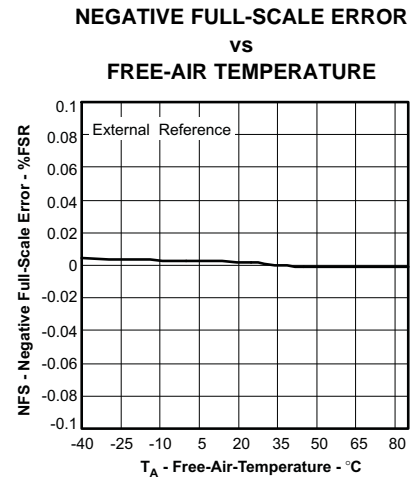

Figure 12.

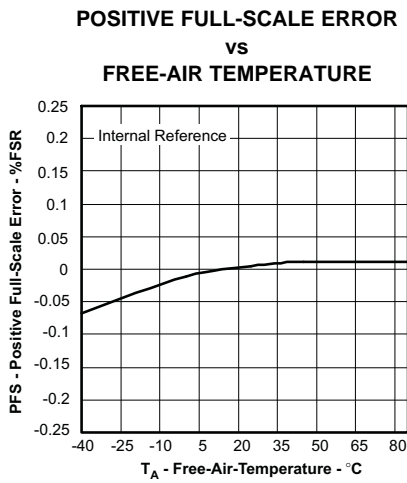

Figure 13.

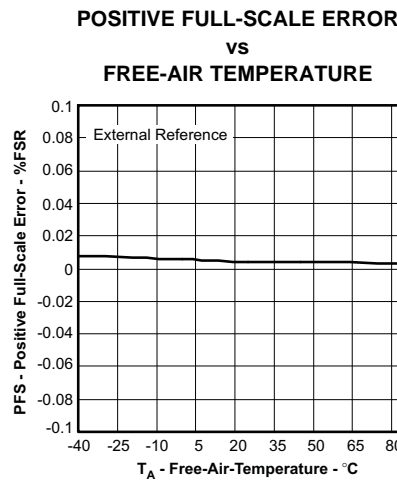

Figure 14.

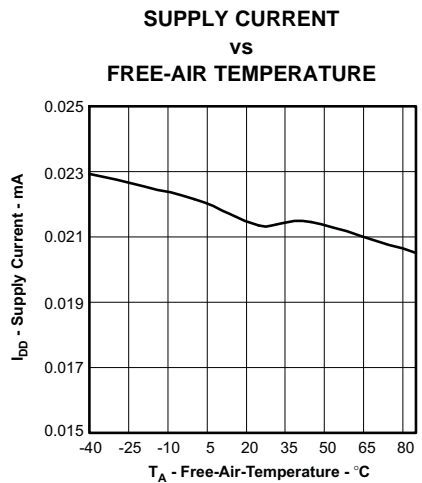

Figure 15.

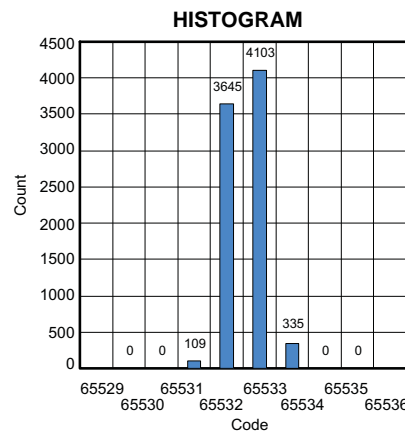

Figure 16.

[查询ADS8515 供应商](#)

TYPICAL CHARACTERISTICS (continued)

INL

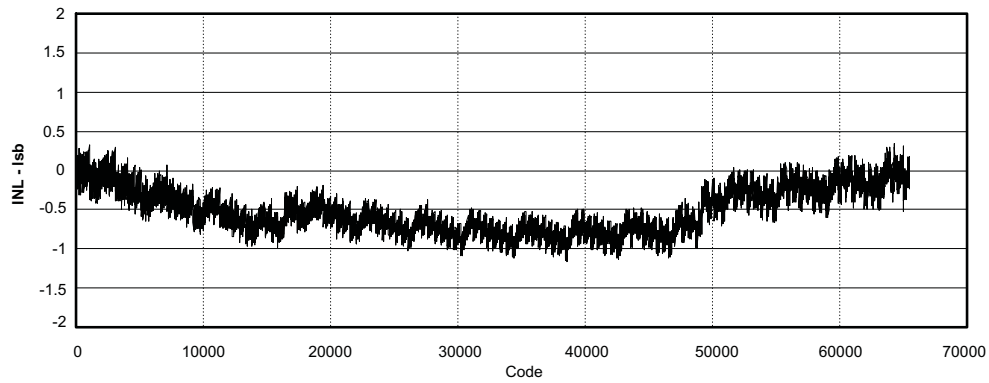

Figure 17.

DNL

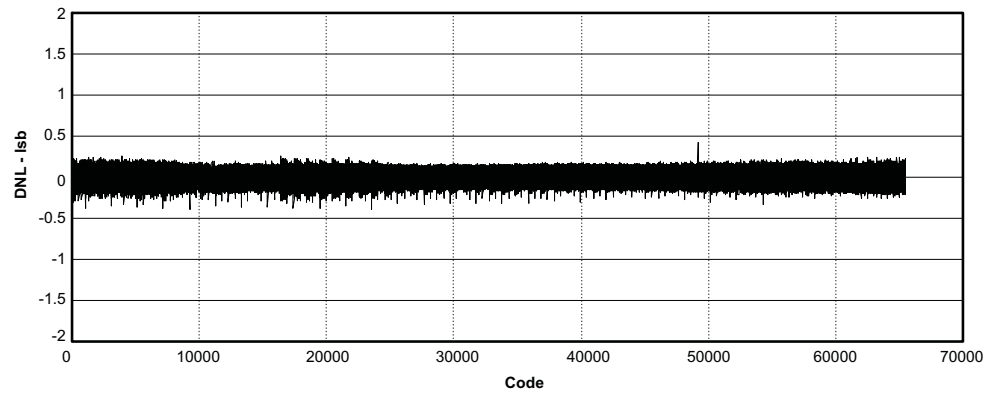

Figure 18.

BASIC OPERATION

Figure 19 shows a basic circuit to operate the ADS8515 with a full parallel data output. Taking R/\overline{C} (pin 24) low for a minimum of 40 ns initiates a conversion. $BUSY$ (pin 26) goes low and stays low until the conversion is completed and the output registers are updated. Data are output in binary two's complement with the MSB on pin 6. $BUSY$ going high can be used to latch the data.

The ADS8515 begins tracking the input signal at the end of the conversion. Allowing 4 μ s between convert commands assures accurate acquisition of a new signal.

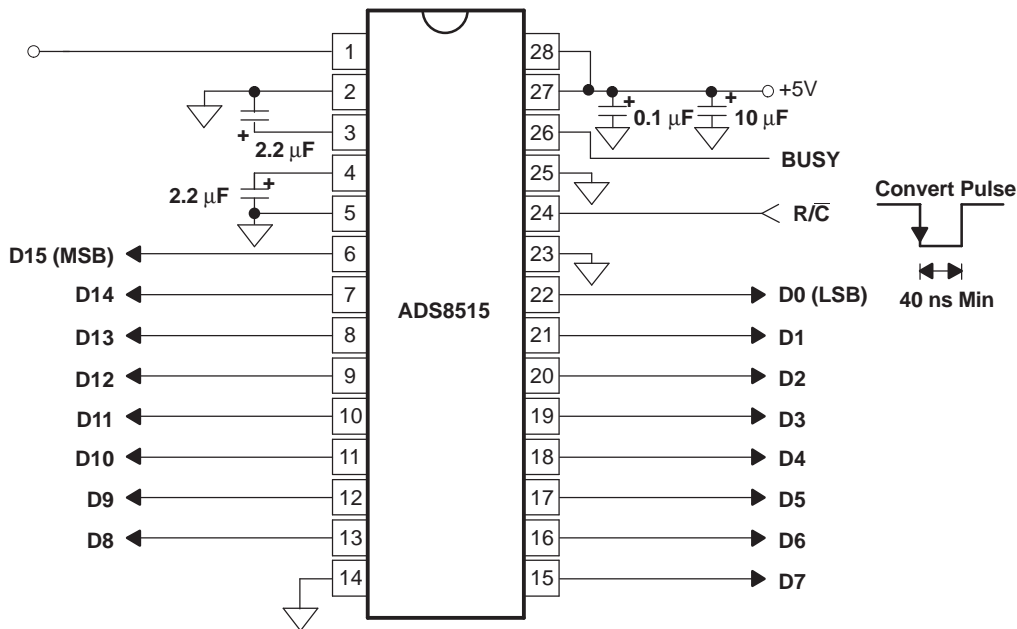

Figure 19. Basic Operation

STARTING A CONVERSION

The combination of \overline{CS} (pin 25) and R/\overline{C} (pin 24) held low for a minimum of 40 ns immediately puts the sample/hold of the ADS8515 in the hold state and starts conversion n . $BUSY$ (pin 26) goes low and stays low until conversion n is completed and the internal output register has been updated.

The ADS8515 begins tracking the input signal at the end of the conversion. Allowing 4 μ s between convert commands assures accurate acquisition of a new signal. Refer to [Table 1](#) for a summary of \overline{CS} , R/\overline{C} , and $BUSY$ states and [Figure 21](#), [Figure 22](#), and [Figure 23](#) for the timing diagrams.

\overline{CS} and R/\overline{C} are internally ORed and level triggered. There is no requirement regarding which input goes low first when initiating a conversion. If, however, it is critical that \overline{CS} or R/\overline{C} initiates conversion n , be sure the less critical input is low at least 10 ns prior to the initiating input.

To reduce the number of control pins, \overline{CS} can be tied low using R/\overline{C} to control the read and convert modes. The parallel output becomes active whenever R/\overline{C} goes high. Refer to the Reading Data section.

Table 1. Control Line Functions for Read and Convert

\overline{CS}	R/\overline{C}	$BUSY$	OPERATION
1	X	X	None. Databus is in Hi-Z state.
↓	0	1	Initiates conversion n . Databus remains in Hi-Z state.
0	↓	1	Initiates conversion n . Databus enters Hi-Z state.
0	1	↑	Conversion n completed. Valid data from conversion n on the databus.
↓	1	1	Enables databus with valid data from conversion n .
↓	1	0	Enables databus with valid data from conversion -1 ⁽¹⁾ . Conversion n in progress.
0	↑	0	Enables databus with valid data from conversion -1 ⁽¹⁾ . Conversion n in progress.
0	0	↑	New conversion initiated without acquisition of a new signal. Data is invalid. \overline{CS} and/or R/\overline{C} must be high when $BUSY$ goes high.
X	X	0	Conversion n in progress.

(1) See [Figure 21](#) and [Figure 22](#) for constraints on data valid from conversion $n - 1$.

READING DATA

The ADS8515 outputs full or byte-reading parallel data in binary twos complement data output format. The parallel output is active when R/\overline{C} (pin 24) is high and \overline{CS} (pin 25) is low. Any other combination of \overline{CS} and R/\overline{C} 3-states the parallel output. Valid conversion data can be read in a full parallel, 16-bit word or two 8-bit bytes on pins 6 to 13 and pins 15 to 22. BYTE (pin 23) can be toggled to read both bytes within one conversion cycle. Refer to [Table 2](#) for ideal output codes and [Figure 20](#) for bit locations relative to the state of BYTE.

Table 2. Ideal Input Voltages and Output Codes

DESCRIPTION	ANALOG INPUT	DIGITAL OUTPUT BINARY TWOS COMPLEMENT	
		BINARY CODE	HEX CODE
Full-scale range	± 10 V		
Least significant bit (LSB)	305 μ V		
Full scale (10 V – 1 LSB)	9.999695 V	0111 1111 1111 1111	7FFF
Midscale	0 V	0000 0000 0000 0000	0000
One LSB below midscale	-305 μ V	1111 1111 1111 1111	FFFF
-Full scale	-10 V	1000 0000 0000 0000	8000

PARALLEL OUTPUT (After a Conversion)

After conversion n is completed and the output registers have been updated, $\overline{\text{BUSY}}$ (pin 26) goes high. Valid data from conversion n are available on D15 to D0 (pins 6 to 13 and 15 to 22). $\overline{\text{BUSY}}$ going high can be used to latch the data. Refer to Table 3 and Figure 21, Figure 22, and Figure 23 for timing specifications.

PARALLEL OUTPUT (During a Conversion)

After conversion n has been initiated, valid data from conversion -1 can be read and are valid up to t_2 after the start of conversion n . Do not attempt to read data from t_2 after the start of conversion n until $\overline{\text{BUSY}}$ (pin 26) goes high; this may result in reading invalid data. Refer to Table 3 and Figure 21, Figure 22, and Figure 23 for timing specifications.

Note: For the best possible performance, data should not be read during a conversion. The switching noise of the asynchronous data transfer can cause digital feedthrough degrading the converter performance.

The number of control lines can be reduced by tying $\overline{\text{CS}}$ low while using the falling edge of $\overline{\text{R}/\overline{\text{C}}}$ to initiate conversions and the rising edge of $\overline{\text{R}/\overline{\text{C}}}$ to activate the output mode of the converter. See Figure 21.

Table 3. Conversion Timing

SYMBOL	DESCRIPTION	MIN	TYP	MAX	UNITS
t_{w1}	Pulse duration, convert	40			ns
t_a	Access time, data valid after $\overline{\text{R}/\overline{\text{C}}}$ low		0.8	1.2	μs
t_{pd}	Propagation delay time, $\overline{\text{BUSY}}$ from $\overline{\text{R}/\overline{\text{C}}}$ low		6	20	ns
t_{w2}	Pulse duration, $\overline{\text{BUSY}}$ low			2	μs
t_{d1}	Delay time, $\overline{\text{BUSY}}$ after end of conversion		5		ns
t_{d2}	Delay time, aperture		5		ns
t_{conv}	Conversion time			2	μs
t_{acq}	Acquisition time	2			μs
t_{dis}	Disable time, bus	10	15	83	ns
t_{d3}	Delay time, $\overline{\text{BUSY}}$ after data valid	35	50		ns
t_v	Valid time, previous data remains valid after $\overline{\text{R}/\overline{\text{C}}}$ low	1.5	2		μs
$t_{conv} + t_{acq}$	Throughput time			4	μs
t_{su}	Setup time, $\overline{\text{R}/\overline{\text{C}}}$ to $\overline{\text{CS}}$	10			ns
t_c	Cycle time between conversions	4			μs
t_{en}	Enable time, bus	10	15	30	ns
t_{d4}	Delay time, BYTE	10	15	30	ns

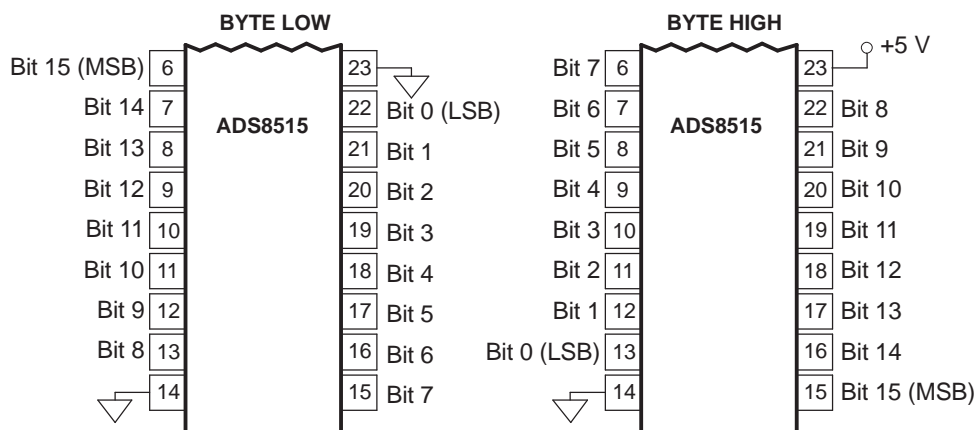

Figure 20. Bit Locations Relative to State of BYTE (Pin 23)

[查询ADS8515 快应用商](#)

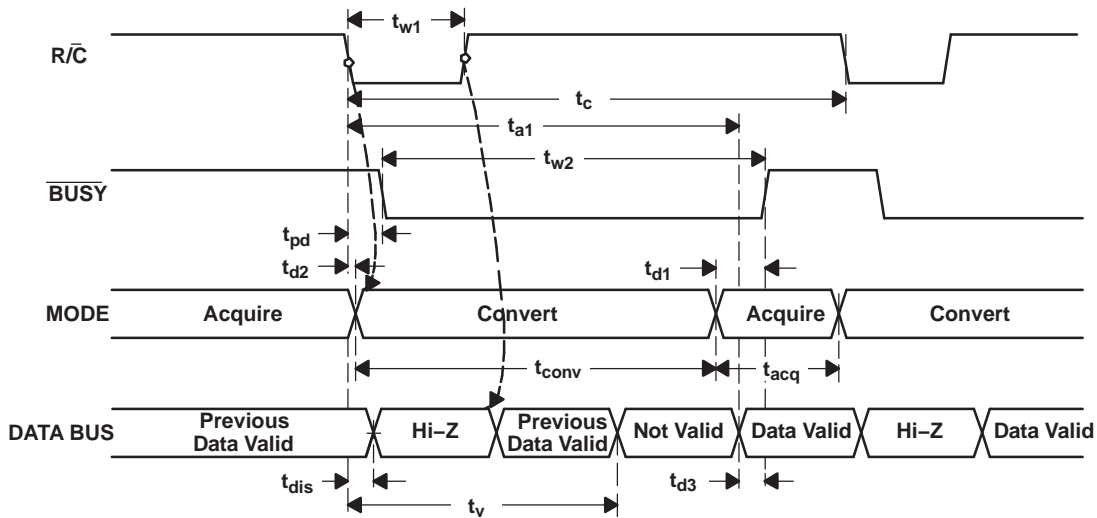

Figure 21. Conversion Timing with Outputs Enabled after Conversion (\overline{CS} Tied Low)

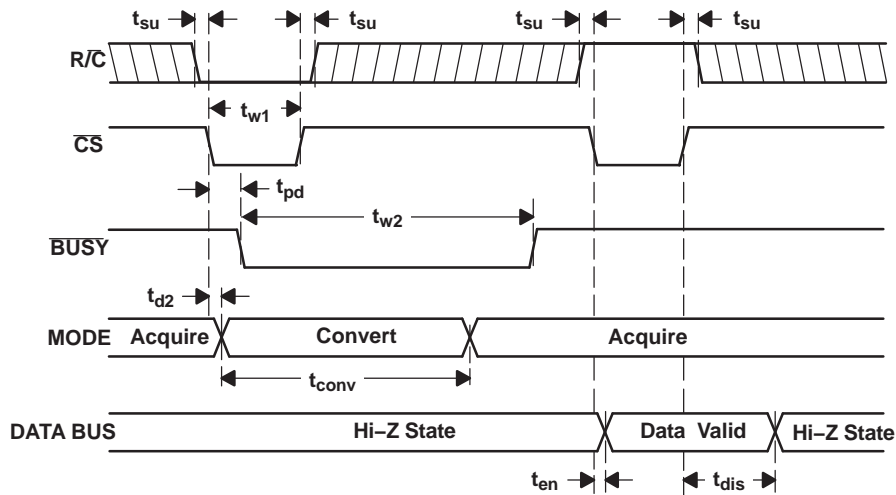

Figure 22. Using \overline{CS} to Control Conversion and Read Timing

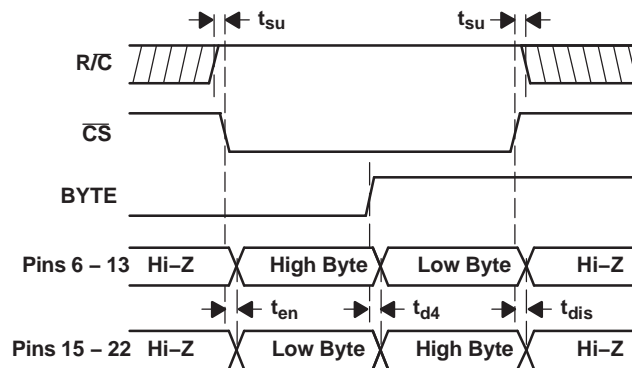

Figure 23. Using \overline{CS} and **BYTE** to Control Data Bus

ADC RESET

The ADC reset function of the ADS8515 can be used to terminate the current conversion cycle. Bringing $\overline{R/C}$ low for at least 40 ns while BUSY is low will initiate the ADC reset. To initiate a new conversion, $\overline{R/C}$ must return to the high state and remain high long enough to acquire a new sample (see Table 3, t_c) before going low to initiate the next conversion sequence. In applications that do not monitor the BUSY signal, it is recommended that the ADC reset function be implemented as part of a system initialization sequence.

INPUT RANGES

The ADS8515 offers a standard ± 10 -V input range. Figure 24 shows the necessary circuit connections for the ADS8515 with and without hardware trim. Offset and full-scale error specifications are tested and specified with the fixed resistors shown in Figure 25(b). Full-scale error includes offset and gain errors measured at both +FS and –FS. Adjustments for offset and gain are described in the Calibration section of this data sheet.

The offset and gain are adjusted internally to allow external trimming with a single supply. The external resistors compensate for this adjustment and can be left out if the offset and gain are corrected in software (refer to the Calibration section).

The nominal input impedance of 6.35 k Ω results from the combination of the internal resistor network shown on the front page of the product data sheet. The input resistor divider network provides inherent overvoltage protection assured to at least ± 25 V. The 1% resistors used for the external circuitry do not compromise the accuracy or drift of the converter. They have little influence relative to the internal resistors, and tighter tolerances are not required.

The input signal must be referenced to AGND1. This minimizes the ground loop problem typical to analog designs. The analog signal should be driven by a low impedance source. A typical driving circuit using an OPA627 or OPA132 is shown in Figure 24.

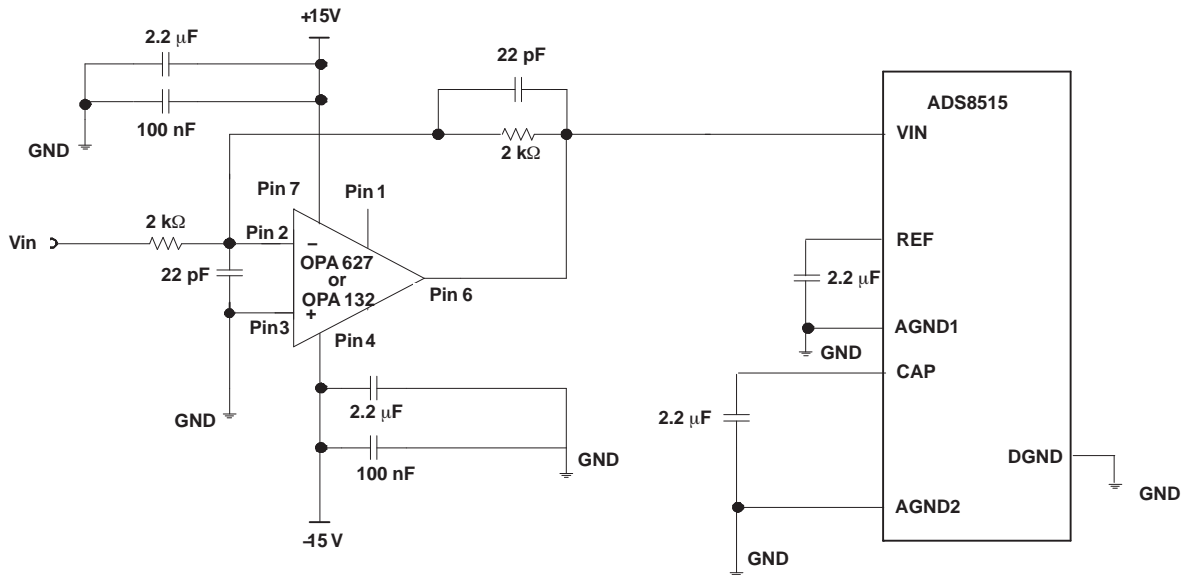

Figure 24. Typical Driving Circuit (± 10 V, No Trim)

APPLICATION INFORMATION

CALIBRATION

The gain of the ADS8515 can be trimmed in software. To achieve optimum performance, several iterations may be required.

Hardware Calibration

To calibrate the gain of the ADS8515, install the resistors and potentiometer as shown in Figure 25(a). The calibration range is approximately ± 100 mV.

Software Calibration

The offset and gain of the ADS8515 is calibrated with software. See Figure 25(b) for the circuit connections.

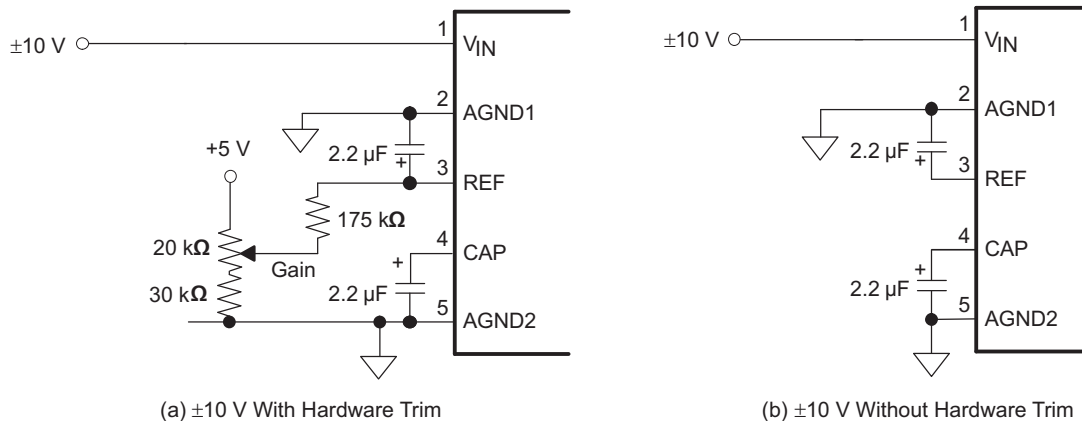

Note: Use 1% metal film resistors.

Figure 25. Circuit Diagram For Software Trim

REFERENCE

The ADS8515 can operate with its internal 4.096-V reference or an external reference. By applying an external reference to pin 5, the internal reference can be bypassed. The reference voltage at REF is buffered internally with the output on CAP (pin 4).

The internal reference has an 8 ppm/°C drift (typical) and accounts for approximately 20% of the full-scale error (FSE = $\pm 0.5\%$ for low grade, $\pm 0.25\%$ for high grade).

REF

REF (pin 3) is an input for an external reference or the output for the internal 4.096-V reference. A 2.2- μ F capacitor should be connected as close to the REF pin as possible. The capacitor and the output resistance of REF create a low-pass filter to bandlimit noise on the reference. Using a smaller value capacitor introduces more noise to the reference degrading the SNR and SINAD. The REF pin should not be used to drive external ac or dc loads.

The range for the external reference is 3.9 V to 4.2 V and determines the actual LSB size. Increasing the reference voltage increases the full-scale range and the LSB size of the converter which can improve the SNR.

CAP

CAP (pin 4) is the output of the internal reference buffer. A 2.2- μ F capacitor should be placed as close to the CAP pin as possible to provide optimum switching currents for the CDAC throughout the conversion cycle and compensation for the output of the internal buffer. Using a capacitor any smaller than 1 μ F can cause the output buffer to oscillate and may not have sufficient charge for the CDAC. Capacitor values larger than 2.2 μ F have little effect on improving performance. The ESR (equivalent series resistance) of these compensation capacitors is also critical. Keep the total ESR under 3 Ω . See the [Typical Characteristics](#) section for how the worst case INL is affected by ESR.

The output of the buffer is capable of driving up to 2 mA of current to a dc load, but any external load from the CAP pin may degrade the linearity of the ADS8515. Using an external buffer allows the internal reference to be used for larger dc loads and ac loads. Do not attempt to directly drive an ac load with the output voltage on CAP. This causes performance degradation of the converter. The ESR (equivalent series resistance) of these compensation capacitors is also critical. Keep the total ESR under 3 Ω . See the [Typical Characteristics](#) section concerning how ESR affects performance.

LAYOUT

POWER

The analog power pin (V_{ANA}) and digital power pin (V_{DIG}) can be tied together from the same +5V power supply, or from two different power-supply sources. The ADS8515 uses 90% of its power from the analog circuitry, and therefore should be considered as an analog component. Care must be taken to ensure that both the analog and digital power supplies power on before any voltage is applied to the analog input pin. Failure to do so may create a latch-up condition. There is no power sequencing requirement between V_{ANA} and V_{DIG} .

GROUNDING

Three ground pins are present on the ADS8515. DGND is the digital supply ground. AGND2 is the analog supply ground. AGND1 is the ground which all analog signals internal to the A/D converter are referenced. AGND1 is more susceptible to current induced voltage drops and must have the path of least resistance back to the power supply.

All the ground pins of the A/D converter should be tied to the analog ground plane, separated from the system digital logic ground, to achieve optimum performance. Both analog and digital ground planes should be tied to the *system* ground as near to the power supplies as possible. This helps to prevent dynamic digital ground currents from modulating the analog ground through a common impedance to power ground.

SIGNAL CONDITIONING

The FET switches used for the sample hold on many CMOS A/D converters release a significant amount of charge injection which can cause the driving op amp to oscillate. The FET switch on the ADS8515, compared to the FET switches on other CMOS A/D converters, releases 5% to 10% of the charge. There is also a resistive front end which attenuates any charge which is released. The end result is a minimal requirement for the antialias filter on the front end. Any op amp sufficient for the signal in an application is sufficient to drive the ADS8515.

The resistive front end of the ADS8515 also provides an assured ± 25 -V overvoltage protection. In most cases, this eliminates the need for external input protection circuitry.

INTERMEDIATE LATCHES

The ADS8515 does have 3-state outputs for the parallel port, but intermediate latches should be used if the bus is to be active during conversions. If the bus is not active during conversion, the 3-state outputs can be used to isolate the A/D converter from other peripherals on the same bus. The 3-state outputs can also be used when the A/D converter is the only peripheral on the data bus.

Intermediate latches are beneficial on any monolithic A/D converter. The ADS8515 has an internal LSB size of 38 μ V. Transients from fast switching signals on the parallel port, even when the A/D converter is 3-stated, can be coupled through the substrate to the analog circuitry causing degradation of converter performance.

[查询ADS8515 快应用](#)

REVISION HISTORY

NOTE: Page numbers for previous revisions may differ from page numbers in the current version.

Changes from Revision C (August 2010) to Revision D	Page
• Deleted row from <i>Absolute Maximum Ratings</i> regarding V_{DIG} to V_{ANA}	2
• Deleted text regarding V_{ANA} from the pin 28 description in the <i>Pin Description</i> table	5
• Changed text in first and second sentences of the <i>Power</i> section	15

Changes from Revision B (June 2010) to Revision C	Page
• Updated document format to current standards	1
• Added text to end of <i>Power</i> section	15



www.ti.com

PACKAG

PACKAGING INFORMATION

Orderable Device	Status ⁽¹⁾	Package Type	Package Drawing	Pins	Package Qty	Eco Plan ⁽²⁾	Lead/Ball Finish	MSL Peak Temp
ADS8515IBDBR	ACTIVE	SSOP	DB	28	2000	Green (RoHS & no Sb/Br)	CU NIPDAU	Level-2-2600
ADS8515IBDBG4	ACTIVE	SSOP	DB	28	2000	Green (RoHS & no Sb/Br)	CU NIPDAU	Level-2-2600
ADS8515IDB	ACTIVE	SSOP	DB	28	50	Green (RoHS & no Sb/Br)	CU NIPDAU	Level-2-2600
ADS8515IDBG4	ACTIVE	SSOP	DB	28	50	Green (RoHS & no Sb/Br)	CU NIPDAU	Level-2-2600
ADS8515IDBR	ACTIVE	SSOP	DB	28	2000	Green (RoHS & no Sb/Br)	CU NIPDAU	Level-2-2600
ADS8515IDBRG4	ACTIVE	SSOP	DB	28	2000	Green (RoHS & no Sb/Br)	CU NIPDAU	Level-2-2600

⁽¹⁾ The marketing status values are defined as follows:

ACTIVE: Product device recommended for new designs.

LIFEBUY: TI has announced that the device will be discontinued, and a lifetime-buy period is in effect.

NRND: Not recommended for new designs. Device is in production to support existing customers, but TI does not recommend using this part in a new design.

PREVIEW: Device has been announced but is not in production. Samples may or may not be available.

OBsolete: TI has discontinued the production of the device.

⁽²⁾ Eco Plan - The planned eco-friendly classification: Pb-Free (RoHS), Pb-Free (RoHS Exempt), or Green (RoHS & no Sb/Br) - please check <http://www.ti.com> for more information and additional product content details.

TBD: The Pb-Free/Green conversion plan has not been defined.

Pb-Free (RoHS): TI's terms "Lead-Free" or "Pb-Free" mean semiconductor products that are compatible with the current RoHS requirements for all lead not exceed 0.1% by weight in homogeneous materials. Where designed to be soldered at high temperatures, TI Pb-Free products are suitable for high temperature soldering processes.

Pb-Free (RoHS Exempt): This component has a RoHS exemption for either 1) lead-based flip-chip solder bumps used between the die and package, or 2) lead-based die attach between the die and leadframe. The component is otherwise considered Pb-Free (RoHS compatible) as defined above.

Green (RoHS & no Sb/Br): TI defines "Green" to mean Pb-Free (RoHS compatible), and free of Bromine (Br) and Antimony (Sb) based flame retardants (unless otherwise designated in homogeneous material).

⁽³⁾ MSL, Peak Temp. -- The Moisture Sensitivity Level rating according to the JEDEC industry standard classifications, and peak solder temperature.

Important Information and Disclaimer: The information provided on this page represents TI's knowledge and belief as of the date that it is provided. TI does not warrant, represent, or guarantee the accuracy, reliability, or completeness of the information provided by third parties, and makes no representation or warranty as to the accuracy of such information. Efforts are underway to better integrate information from third parties. TI continues to take reasonable steps to provide representative and accurate information but may not have conducted destructive testing or chemical analysis on all TI and TI suppliers consider certain information to be proprietary, and thus CAS numbers and other limited information may not be available for release.

[查询"ADS8515"供应商](#)



PACKAG

In no event shall TI's liability arising out of such information exceed the total purchase price of the TI part(s) at issue in this document sold by TI to Cu

TAPE AND REEL INFORMATION

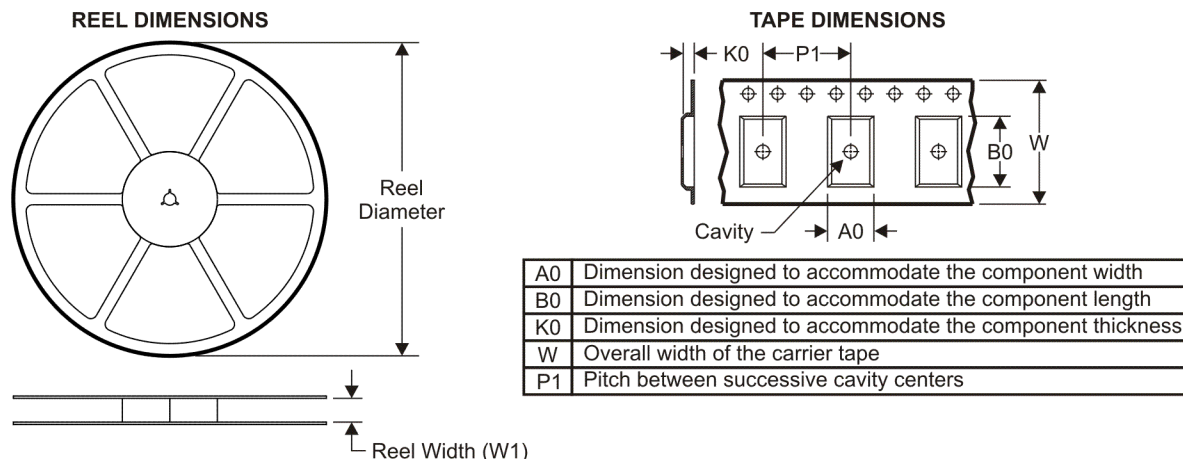

QUADRANT ASSIGNMENTS FOR PIN 1 ORIENTATION IN TAPE

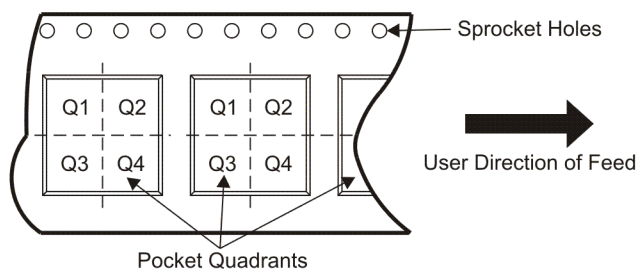

*All dimensions are nominal

Device	Package Type	Package Drawing	Pins	SPQ	Reel Diameter (mm)	Reel Width W1 (mm)	A0 (mm)	B0 (mm)	K0 (mm)	P1 (mm)	W (mm)	Pin1 Quadrant
ADS8515IBDBR	SSOP	DB	28	2000	330.0	16.4	8.1	10.4	2.5	12.0	16.0	Q1
ADS8515IDBR	SSOP	DB	28	2000	330.0	16.4	8.2	10.5	2.5	12.0	16.0	Q1

TAPE AND REEL BOX DIMENSIONS



*All dimensions are nominal

Device	Package Type	Package Drawing	Pins	SPQ	Length (mm)	Width (mm)	Height (mm)
ADS8515IBDBR	SSOP	DB	28	2000	346.0	346.0	33.0
ADS8515IDBR	SSOP	DB	28	2000	346.0	346.0	33.0

DB (R-PDSO-G**)

PLASTIC SMALL-OUTLINE

28 PINS SHOWN

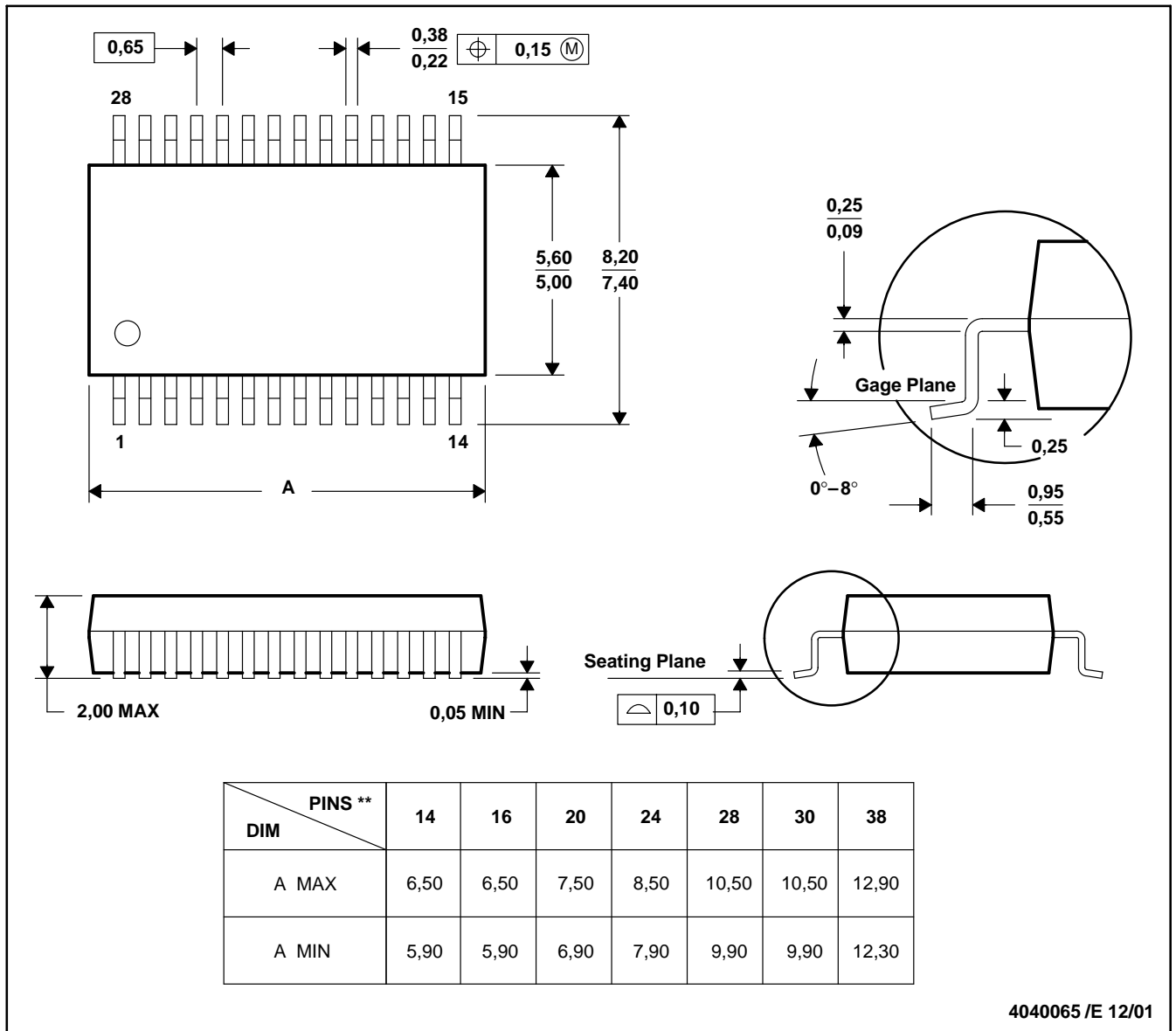

- NOTES: A. All linear dimensions are in millimeters.
 B. This drawing is subject to change without notice.
 C. Body dimensions do not include mold flash or protrusion not to exceed 0,15.
 D. Falls within JEDEC MO-150

IMPORTANT NOTICE

Texas Instruments Incorporated and its subsidiaries (TI) reserve the right to make corrections, modifications, enhancements, improvements, and other changes to its products and services at any time and to discontinue any product or service without notice. Customers should obtain the latest relevant information before placing orders and should verify that such information is current and complete. All products are sold subject to TI's terms and conditions of sale supplied at the time of order acknowledgment.

TI warrants performance of its hardware products to the specifications applicable at the time of sale in accordance with TI's standard warranty. Testing and other quality control techniques are used to the extent TI deems necessary to support this warranty. Except where mandated by government requirements, testing of all parameters of each product is not necessarily performed.

TI assumes no liability for applications assistance or customer product design. Customers are responsible for their products and applications using TI components. To minimize the risks associated with customer products and applications, customers should provide adequate design and operating safeguards.

TI does not warrant or represent that any license, either express or implied, is granted under any TI patent right, copyright, mask work right, or other TI intellectual property right relating to any combination, machine, or process in which TI products or services are used. Information published by TI regarding third-party products or services does not constitute a license from TI to use such products or services or a warranty or endorsement thereof. Use of such information may require a license from a third party under the patents or other intellectual property of the third party, or a license from TI under the patents or other intellectual property of TI.

Reproduction of TI information in TI data books or data sheets is permissible only if reproduction is without alteration and is accompanied by all associated warranties, conditions, limitations, and notices. Reproduction of this information with alteration is an unfair and deceptive business practice. TI is not responsible or liable for such altered documentation. Information of third parties may be subject to additional restrictions.

Resale of TI products or services with statements different from or beyond the parameters stated by TI for that product or service voids all express and any implied warranties for the associated TI product or service and is an unfair and deceptive business practice. TI is not responsible or liable for any such statements.

TI products are not authorized for use in safety-critical applications (such as life support) where a failure of the TI product would reasonably be expected to cause severe personal injury or death, unless officers of the parties have executed an agreement specifically governing such use. Buyers represent that they have all necessary expertise in the safety and regulatory ramifications of their applications, and acknowledge and agree that they are solely responsible for all legal, regulatory and safety-related requirements concerning their products and any use of TI products in such safety-critical applications, notwithstanding any applications-related information or support that may be provided by TI. Further, Buyers must fully indemnify TI and its representatives against any damages arising out of the use of TI products in such safety-critical applications.

TI products are neither designed nor intended for use in military/aerospace applications or environments unless the TI products are specifically designated by TI as military-grade or "enhanced plastic." Only products designated by TI as military-grade meet military specifications. Buyers acknowledge and agree that any such use of TI products which TI has not designated as military-grade is solely at the Buyer's risk, and that they are solely responsible for compliance with all legal and regulatory requirements in connection with such use.

TI products are neither designed nor intended for use in automotive applications or environments unless the specific TI products are designated by TI as compliant with ISO/TS 16949 requirements. Buyers acknowledge and agree that, if they use any non-designated products in automotive applications, TI will not be responsible for any failure to meet such requirements.

Following are URLs where you can obtain information on other Texas Instruments products and application solutions:

Products		Applications	
Amplifiers	amplifier.ti.com	Audio	www.ti.com/audio
Data Converters	dataconverter.ti.com	Automotive	www.ti.com/automotive
DLP® Products	www.dlp.com	Communications and Telecom	www.ti.com/communications
DSP	dsp.ti.com	Computers and Peripherals	www.ti.com/computers
Clocks and Timers	www.ti.com/clocks	Consumer Electronics	www.ti.com/consumer-apps
Interface	interface.ti.com	Energy	www.ti.com/energy
Logic	logic.ti.com	Industrial	www.ti.com/industrial
Power Mgmt	power.ti.com	Medical	www.ti.com/medical
Microcontrollers	microcontroller.ti.com	Security	www.ti.com/security
RFID	www.ti-rfid.com	Space, Avionics & Defense	www.ti.com/space-avionics-defense
RF/IF and ZigBee® Solutions	www.ti.com/lprf	Video and Imaging	www.ti.com/video
		Wireless	www.ti.com/wireless-apps