

REVISIONS

| LTR | DESCRIPTION | DATE (YR-MO-DA) | APPROVED |
|--|-------------|-----------------|----------|
| 查询"5962-9686101Q2A"供应商 | | | |

| | | | | | | | | | | | | | | | | | | |
|----------------------|-------|----|----|----|---|---|---|---|---|---|---|----|----|----|----|----|--|--|
| REV | | | | | | | | | | | | | | | | | | |
| SHEET | | | | | | | | | | | | | | | | | | |
| REV | | | | | | | | | | | | | | | | | | |
| SHEET | 15 | 16 | 17 | 18 | | | | | | | | | | | | | | |
| REV STATUS OF SHEETS | REV | | | | | | | | | | | | | | | | | |
| | SHEET | | 1 | 2 | 3 | 4 | 5 | 6 | 7 | 8 | 9 | 10 | 11 | 12 | 13 | 14 | | |

| | | | | |
|---|---|--|---------------------------|-------------------|
| <p>PMIC N/A</p> <p>STANDARD MICROCIRCUIT DRAWING</p> <p>THIS DRAWING IS AVAILABLE FOR USE BY ALL DEPARTMENTS AND AGENCIES OF THE DEPARTMENT OF DEFENSE</p> <p>AMSC N/A</p> | <p>PREPARED BY Joseph A. Kerby</p> | <p>DEFENSE SUPPLY CENTER COLUMBUS COLUMBUS, OHIO 43216</p> <p>MICROCIRCUIT, DIGITAL, ADVANCED HIGH SPEED CMOS, DUAL POSITIVE-EDGE-TRIGGERED D-TYPE FLIP-FLOP WITH CLEAR AND PRESET, TTL COMPATIBLE INPUTS, MONOLITHIC SILICON</p> | | |
| | <p>CHECKED BY Thanh V. Nguyen</p> | | | |
| | <p>APPROVED BY Monica L. Poelking</p> | | | |
| | <p>DRAWING APPROVAL DATE 96-08-30</p> | | | |
| | <p>REVISION LEVEL</p> | | | |
| <table border="1"> <tr> <td>SIZE A</td> <td>CAGE CODE 67268</td> <td>5962-96861</td> </tr> </table> | | SIZE A | CAGE CODE 67268 | 5962-96861 |
| SIZE A | CAGE CODE 67268 | 5962-96861 | | |
| <p>SHEET 1 OF 18</p> | | | | |

DESC FORM 193
JUL 94

5962-E536-96

DISTRIBUTION STATEMENT A. Approved for public release; distribution is unlimited.

9004708 0024734 726

1. SCOPE

1.1 Scope. This drawing documents two product assurance class levels consisting of high reliability (device classes Q and M) and space application (device class V). A choice of case outlines and lead finishes are available and are reflected in the Part or Identifying Number (PIN). When available, a choice of Radiation Hardness Assurance (RHA) levels are reflected in the PIN.

1.2 PIN. The PIN is as shown in the following example:

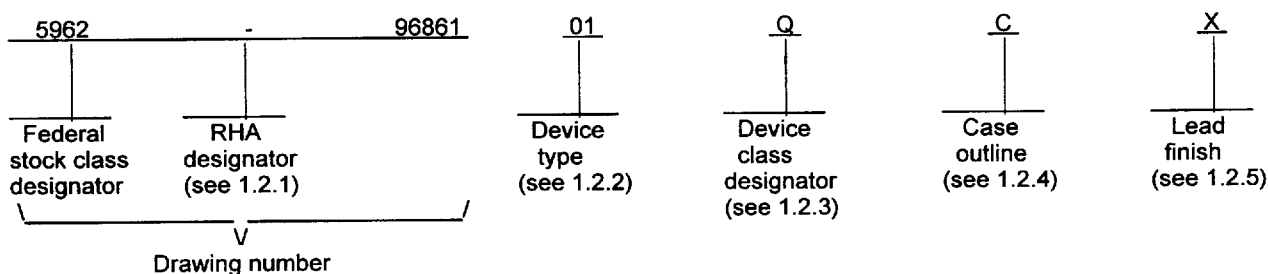

1.2.1 RHA designator. Device classes Q and V RHA marked devices meet the MIL-PRF-38535 specified RHA levels and are marked with the appropriate RHA designator. Device class M RHA marked devices meet the MIL-PRF-38535, appendix A specified RHA levels and are marked with the appropriate RHA designator. A dash (-) indicates a non-RHA device.

1.2.2 Device type(s). The device type(s) identify the circuit function as follows:

| <u>Device type</u> | <u>Generic number</u> | <u>Circuit function</u> |
|--------------------|-----------------------|--|
| 01 | 54AHCT74 | Dual positive-edge-triggered D-type flip-flop with clear and preset, TTL compatible inputs |

1.2.3 Device class designator. The device class designator is a single letter identifying the product assurance level as follows:

| <u>Device class</u> | <u>Device requirements documentation</u> |
|---------------------|---|
| M | Vendor self-certification to the requirements for MIL-STD-883 compliant, non-JAN class level B microcircuits in accordance with MIL-PRF-38535, appendix A |
| Q or V | Certification and qualification to MIL-PRF-38535 |

1.2.4 Case outline(s). The case outline(s) are as designated in MIL-STD-1835 and as follows:

| <u>Outline letter</u> | <u>Descriptive designator</u> | <u>Terminals</u> | <u>Package style</u> |
|-----------------------|-------------------------------|------------------|------------------------------|
| C | GDIP1-T14 or CDIP2-T14 | 14 | Dual-in-line |
| D | GDFP1-F14 or CDFP2-F14 | 14 | Flat pack |
| 2 | CQCC1-N20 | 20 | Square leadless chip carrier |

1.2.5 Lead finish. The lead finish is as specified in MIL-PRF-38535 for device classes Q and V or MIL-PRF-38535, appendix A for device class M.

| | | | |
|---|------------------|----------------|-------------------|
| STANDARD MICROCIRCUIT DRAWING DEFENSE SUPPLY CENTER COLUMBUS COLUMBUS, OHIO 43216-5000 | SIZE A | | 5962-96861 |
| | | REVISION LEVEL | SHEET 2 |

1.3 Absolute maximum ratings. 1/ 2/ 3/

| | |
|---|---------------------------|
| Supply voltage range (V_{CC}) | -0.5 V dc to +7.0 V dc |
| DC input voltage range (V_{IN}) | -0.5 V dc to +7.0 V dc 4/ |
| DC output voltage range (V_{OUT}) | -0.5 V dc to +7.0 V dc 4/ |
| DC input clamp current (I_{IK}) ($V_{IN} < 0.0$ or $V_{IN} > V_{CC}$) | -20 mA |
| DC output clamp current (I_{OK}) ($V_{OUT} < 0.0$ or $V_{OUT} > V_{CC}$) | -20 mA |
| Continuous output current (I_O) ($V_O = 0$ to V_{CC}) | ± 25 mA |
| Continuous current through V_{CC} or GND | ± 50 mA |
| Storage temperature range (T_{STG}) | -65°C to +150°C |
| Lead temperature (soldering, 10 seconds) | +300°C |
| Thermal resistance, junction-to-case (Θ_{JC}) | See MIL-STD-1835 |
| Junction temperature (T_J) | +175°C |
| Maximum power dissipation at $T_A = +55^\circ\text{C}$ (in still air) (P_D) | 500 mW |

1.4 Recommended operating conditions. 2/ 3/ 5/

| | |
|---|------------------------|
| Supply voltage range (V_{CC}) | +4.5 V dc to +5.5 V dc |
| Minimum high level input voltage (V_{IH}) | +2.0 V |
| Maximum low level input voltage (V_{IL}) | +0.8 V |
| Input voltage range (V_{IN}) | +0.0 V dc to V_{CC} |
| Output voltage range (V_{OUT}) | +0.0 V dc to V_{CC} |
| Maximum high level output current (I_{OH}) | -8 mA |
| Maximum low level output current (I_{OL}) | +8 mA |
| Maximum input rise or fall rate ($\Delta t/\Delta V$) | +20 ns/V |
| Case operating temperature range (T_C) | -55°C to +125°C |

1.5 Digital logic testing for device classes Q and V.

Fault coverage measurement of manufacturing logic tests (MIL-STD-883, test method 5012) XX percent 6/

2. APPLICABLE DOCUMENTS

2.1 Government specification, standards, and handbooks. The following specification, standards, and handbooks form a part of this drawing to the extent specified herein. Unless otherwise specified, the issues of these documents are those listed in the issue of the Department of Defense Index of Specifications and Standards (DoDISS) and supplement thereto, cited in the solicitation.

SPECIFICATION

MILITARY

MIL-PRF-38535 - Integrated Circuits, Manufacturing, General Specification for.

- 1/ Stresses above the absolute maximum rating may cause permanent damage to the device. Extended operation at the maximum levels may degrade performance and affect reliability.
- 2/ Unless otherwise noted, all voltages are referenced to GND.
- 3/ The limits for the parameters specified herein shall apply over the full specified V_{CC} range and case temperature range of -55°C to +125°C.
- 4/ The input and output voltage ratings may be exceeded provided that the input and output current ratings are observed.
- 5/ Unused inputs must be held high or low to prevent them from floating.
- 6/ Values will be added when they become available.

| | | | |
|---|------------------|----------------|-------------------|
| STANDARD MICROCIRCUIT DRAWING DEFENSE SUPPLY CENTER COLUMBUS COLUMBUS, OHIO 43216-5000 | SIZE A | | 5962-96861 |
| | | REVISION LEVEL | SHEET 3 |

DESC FORM 193A
JUL 94

9004708 0024736 5T9

STANDARDS

MILITARY
查询 5962-9686101Q2A"供应商

- MIL-STD-883 - Test Methods and Procedures for Microelectronics.
- MIL-STD-973 - Configuration Management.
- MIL-STD-1835 - Microcircuit Case Outlines.

HANDBOOKS

MILITARY

- MIL-HDBK-103 - List of Standard Microcircuit Drawings (SMD's).
- MIL-HDBK-780 - Standard Microcircuit Drawings.

(Unless otherwise indicated, copies of the specification, standards, and handbooks are available from the Standardization Document Order Desk, 700 Robbins Avenue, Building 4D, Philadelphia, PA 19111-5094.)

2.2 Non-Government publications. The following document(s) form a part of this document to the extent specified herein. Unless otherwise specified, the issues of the documents which are DOD adopted are those listed in the issue of the DODISS cited in the solicitation. Unless otherwise specified, the issues of documents not listed in the DODISS are the issues of the documents cited in the solicitation.

ELECTRONIC INDUSTRIES ASSOCIATION (EIA)

- JEDEC Standard No. 20 - Standardized for Description of 54/74ACXXXX and 54/74ACTXXXX Advanced High-Speed CMOS Devices.

(Applications for copies should be addressed to the Electronics Industries Association, 2001 Eye Street, NW, Washington, DC 20006.)

(Non-Government standards and other publications are normally available from the organizations that prepare or distribute the documents. These documents may also be available in or through libraries or other informational services.)

2.3 Order of precedence. In the event of a conflict between the text of this drawing and the references cited herein, the text of this drawing takes precedence. Nothing in this document, however, supersedes applicable laws and regulations unless a specific exemption has been obtained.

3. REQUIREMENTS

3.1 Item requirements. The individual item requirements for device classes Q and V shall be in accordance with MIL-PRF-38535 and as specified herein or as modified in the device manufacturer's Quality Management (QM) plan. The modification in the QM plan shall not affect the form, fit, or function as described herein. The individual item requirements for device class M shall be in accordance with MIL-PRF-38535, appendix A for non-JAN class level B devices and as specified herein.

3.2 Design, construction, and physical dimensions. The design, construction, and physical dimensions shall be as specified in MIL-PRF-38535 and herein for device classes Q and V or MIL-PRF-38535, appendix A and herein for device class M.

3.2.1 Case outlines. The case outlines shall be in accordance with 1.2.4 herein.

3.2.2 Terminal connections. The terminal connections shall be as specified on figure 1.

3.2.3 Truth table. The truth table shall be as specified on figure 2.

3.2.4 Logic diagram. The logic diagram shall be as specified on figure 3.

3.2.5 Ground bounce load circuit and waveforms. The ground bounce load circuit and waveforms shall be as specified on figure 4.

3.2.6 Switching waveforms and test circuit. The switching waveforms and test circuit shall be as specified on figure 5.

3.2.7 Radiation exposure circuit. The radiation exposure circuit shall be as specified when available.

| | | | |
|---|------------------|----------------|-------------------|
| STANDARD MICROCIRCUIT DRAWING DEFENSE SUPPLY CENTER COLUMBUS COLUMBUS, OHIO 43216-5000 | SIZE A | | 5962-96861 |
| | | REVISION LEVEL | SHEET 4 |

3.3 Electrical performance characteristics and postirradiation parameter limits. Unless otherwise specified herein, the electrical performance characteristics and postirradiation parameter limits are as specified in table I and shall apply over the full case operating temperature range.

[查询"5962-9686101Q2A"供应商](#)

3.4 Electrical test requirements. The electrical test requirements shall be the subgroups specified in table II. The electrical tests for each subgroup are defined in table I.

3.5 Marking. The part shall be marked with the PIN listed in 1.2 herein. In addition, the manufacturer's PIN may also be marked as listed in MIL-HDBK-103. For packages where marking of the entire SMD PIN number is not feasible due to space limitations, the manufacturer has the option of not marking the "5962-" on the device. For RHA product using this option, the RHA designator shall still be marked. Marking for device classes Q and V shall be in accordance with MIL-PRF-38535. Marking for device class M shall be in accordance with MIL-PRF-38535, appendix A.

3.5.1 Certification/compliance mark. The certification mark for device classes Q and V shall be a "QML" or "Q" as required in MIL-PRF-38535. The compliance mark for device class M shall be a "C" as required in MIL-PRF-38535, appendix A.

3.6 Certificate of compliance. For device classes Q and V, a certificate of compliance shall be required from a QML-38535 listed manufacturer in order to supply to the requirements of this drawing (see 6.6.1 herein). For device class M, a certificate of compliance shall be required from a manufacturer in order to be listed as an approved source of supply in MIL-HDBK-103 (see 6.6.2 herein). The certificate of compliance submitted to DSCC-VA prior to listing as an approved source of supply for this drawing shall affirm that the manufacturer's product meets, for device classes Q and V, the requirements of MIL-PRF-38535 and herein or for device class M, the requirements of MIL-PRF-38535, appendix A and herein.

3.7 Certificate of conformance. A certificate of conformance as required for device classes Q and V in MIL-PRF-38535 or for device class M in MIL-PRF-38535, appendix A shall be provided with each lot of microcircuits delivered to this drawing.

3.8 Notification of change for device class M. For device class M, notification to DSCC-VA of change of product (see 6.2 herein) involving devices acquired to this drawing is required for any change as defined in MIL-STD-973.

3.9 Verification and review for device class M. For device class M, DSCC, DSCC's agent, and the acquiring activity retain the option to review the manufacturer's facility and applicable required documentation. Offshore documentation shall be made available onshore at the option of the reviewer.

3.10 Microcircuit group assignment for device class M. Device class M devices covered by this drawing shall be in microcircuit group number 38 (see MIL-PRF-38535, appendix A).

| | | | |
|---|-------------------|-----------------------|--------------------|
| STANDARD MICROCIRCUIT DRAWING DEFENSE SUPPLY CENTER COLUMBUS COLUMBUS, OHIO 43216-5000 | SIZE A | | 5962-96861 |
| | | REVISION LEVEL | SHEET 5 |

DESC FORM 193A
JUL 94

■ 9004708 0024738 371 ■

TABLE I. Electrical performance characteristics.

| Test and MIL-STD-883 test method 1/ | Symbol | Test conditions 2/ -55°C ≤ T _C ≤ +125°C +4.5 V ≤ V _{CC} ≤ +5.5 V unless otherwise specified | V _{CC} | Group A subgroups | Limits 3/ | | Unit |
|--|------------------------|---|-----------------|----------------------|-----------|------|------|
| | | | | | Min | Max | |
| High level output voltage 3006 | V _{OH} | For all inputs affecting output under test V _{IN} = 2.0 V or 0.8 V For all other inputs V _{IN} = V _{CC} or GND | 4.5 V | 1, 2, 3 | 3.15 | | V |
| | | | | 1 | 2.5 | | |
| | | | | 2, 3 | 2.4 | | |
| Low level output voltage 3007 | V _{OL} | | 4.5 V | 1, 2, 3 | | 0.1 | V |
| | | | | 1 | | 0.36 | |
| | | | | 2, 3 | | 0.5 | |
| Input current high 3010 | I _{IH} | For input under test, V _{IN} = V _{CC} For all other inputs, V _{IN} = V _{CC} or GND | 5.5 V | 1 | | +0.1 | μA |
| | | | | 2, 3 | | +1.0 | |
| Input current low 3009 | I _{IL} | For input under test, V _{IN} = GND For all other inputs, V _{IN} = V _{CC} or GND | 5.5 V | 1 | | -0.1 | μA |
| | | | | 2, 3 | | -1.0 | |
| Quiescent supply current 3005 | I _{CC} | For all inputs, V _{IN} = V _{CC} or GND I _{OUT} = 0.0 A | 5.5 V | 1 | | 2.0 | μA |
| | | | | 2, 3 | | 20.0 | |
| Quiescent supply current delta, TTL input levels | ΔI _{CC} 4/ | One input at 3.4 V Other inputs at V _{CC} or GND | 5.5 V | 1 | | 1.35 | mA |
| | | | | 2, 3 | | 1.5 | |
| Input capacitance 3012 | C _{IN} | T _C = +25°C, V _{IN} = V _{CC} or GND See 4.4.1c | 5.0 V | 4 | | 10.0 | pF |
| Power dissipation capacitance | C _{PD} 5/ | C _L = 50 pF minimum f = 1 MHz See 4.4.1c | 5.0 V | 4 | | 35.0 | pF |
| Low level ground bounce noise | V _{OLP} 6/ | V _{IH} = 3.0 V, V _{IL} = 0.0 V T _A = +25°C See 4.4.1d See figure 4 | 5.0 V | 4 | | 750 | mV |
| Low level ground bounce noise | V _{OLV} 6/ | | 5.0 V | 4 | | -750 | |
| High level V _{CC} bounce noise | V _{OHP} 6/ | | 5.0 V | 4 | | 250 | |
| High level V _{CC} bounce noise | V _{OHV} 6/ | | 5.0 V | 4 | | -250 | |
| Functional test 3014 | 7/ | V _{IH} = 2.0 V, V _{IL} = 0.8 V Verify output V _O See 4.4.1b | 4.5 V | 7, 8 | L | H | |
| | | | 5.5 V | | | | |

See footnotes at end of table.

| | | | |
|---|-------------------|----------------|-------------------|
| STANDARD MICROCIRCUIT DRAWING DEFENSE SUPPLY CENTER COLUMBUS COLUMBUS, OHIO 43216-5000 | SIZE A | | 5962-96861 |
| | | REVISION LEVEL | SHEET 6 |

TABLE I. Electrical performance characteristics - Continued.

| Test and test method ^{1/} | Symbol | Test conditions ^{2/} -55°C ≤ T _C ≤ +125°C +4.5 V ≤ V _{CC} ≤ +5.5 V unless otherwise specified | V _{CC} | Group A subgroups | Limits ^{3/} | | Unit |
|---|------------------------------------|---|-----------------|-------------------|----------------------|------|------|
| | | | | | Min | Max | |
| Pulse duration | t _w | C _L = 50 pF minimum See figure 5 | 4.5 V and 5.5 V | 9, 10,11 | 5.0 | | ns |
| | | mPRE or mCLR low mCLK high or low | | | | | |
| Setup time, data high or low before mCLK† | t _{s1} | C _L = 50 pF minimum See figure 5 | 4.5 V and 5.5 V | 9, 10,11 | 5.0 | | ns |
| Setup time, PRE or CLR inactive before mCLK† | t _{s2} | C _L = 50 pF minimum See figure 5 | 4.5 V and 5.5 V | 9, 10,11 | 3.5 | | ns |
| Hold time, data high or low after mCLK† | t _h | C _L = 50 pF minimum See figure 5 | 4.5 V and 5.5 V | 9,10,11 | 0 | | ns |
| Maximum operating frequency | f _{MAX} | C _L = 15 pF minimum See figure 5 ^{9/} | 4.5 V and 5.5 V | 9 | 100 | | MHz |
| | | | | 10,11 | 80 | | |
| | | C _L = 50 pF minimum See figure 5 | 4.5 V and 5.5 V | 9 | 80 | | |
| | | | | 10,11 | 65 | | |
| Propagation delay time, mPRE or mCLR to mQ or mQ 3003 | t _{PLH1} ^{8/} | C _L = 15 pF minimum See figure 5 ^{9/} | 4.5 V and 5.5 V | 9 | | 10.4 | ns |
| | | | | 10, 11 | 1.0 | 12.0 | |
| | | C _L = 50 pF minimum See figure 5 | 4.5 V and 5.5 V | 9 | | 11.4 | |
| | | | | 10, 11 | 1.0 | 13.0 | |
| | t _{PHL1} ^{8/} | C _L = 15 pF minimum See figure 5 ^{9/} | 4.5 V and 5.5 V | 9 | | 10.4 | ns |
| | | | | 10, 11 | 1.0 | 12.0 | |
| | | C _L = 50 pF minimum See figure 5 | 4.5 V and 5.5 V | 9 | | 11.4 | |
| | | | | 10, 11 | 1.0 | 13.0 | |
| Propagation delay time, mCLK to mQ or mQ 3003 | t _{PLH2} ^{8/} | C _L = 15 pF minimum See figure 5 ^{9/} | 4.5 V and 5.5 V | 9 | | 7.8 | ns |
| | | | | 10, 11 | 1.0 | 9.0 | |
| | | C _L = 50 pF minimum See figure 5 | 4.5 V and 5.5 V | 9 | | 8.8 | |
| | | | | 10, 11 | 1.0 | 10.0 | |
| | t _{PHL2} ^{8/} | C _L = 15 pF minimum See figure 5 ^{9/} | 4.5 V and 5.5 V | 9 | | 7.8 | ns |
| | | | | 10, 11 | 1.0 | 9.0 | |
| C _L = 50 pF minimum See figure 5 | 4.5 V and 5.5 V | 9 | | 8.8 | | | |
| | | 10, 11 | 1.0 | 10.0 | | | |

See footnotes on next sheet.

| | | | |
|---|------------------|----------------|-------------------|
| STANDARD MICROCIRCUIT DRAWING DEFENSE SUPPLY CENTER COLUMBUS COLUMBUS, OHIO 43216-5000 | SIZE A | | 5962-96861 |
| | | REVISION LEVEL | SHEET 7 |

DESC FORM 193A
JUL 94

9004708 0024740 T2T

TABLE I. Electrical performance characteristics - Continued.

- 1/ For tests not listed in the referenced MIL-STD-883 (e.g. ΔI_{CC}), utilize the general test procedure of 883 under the conditions of 883 for the 2A "供应商" <http://www.icm.com>
- 2/ Each input/output, as applicable, shall be tested at the specified temperature, for the specified limits, to the tests in table I herein. Output terminals not designated shall be high level logic, low level logic, or open, except for all I_{CC} and ΔI_{CC} tests, where the output terminals shall be open. When performing these tests, the current meter shall be placed in the circuit such that all current flows through the meter.
- 3/ For negative and positive voltage and current values, the sign designates the potential difference in reference to GND and the direction of current flow, respectively; and the absolute value of the magnitude, not the sign, is relative to the minimum and maximum limits, as applicable, listed herein.
- 4/ This is the increase in supply current for each input that is at one of the specified TTL voltage levels rather than 0 V or V_{CC} . This test may be performed either one input at a time (preferred method) or with all input pins simultaneously at $V_{IN} = V_{CC} - 2.1$ V (alternate method). Classes Q and V shall use the preferred method. When the test is performed using the alternate test method, the maximum limit is equal to the number of inputs at a high TTL input level times ΔI_{CC} maximum; and the preferred method and limits are guaranteed.
- 5/ Power dissipation capacitance (C_{PD}) determines both the power consumption (P_D) and current consumption (I_S). Where

$$P_D = (C_{PD} + C_L) (V_{CC} \times V_{CC}) f + (I_{CC} \times V_{CC}) + (n \times d \times \Delta I_{CC} \times V_{CC})$$

$$I_S = (C_{PD} + C_L) V_{CC} f + I_{CC} + (n \times d \times \Delta I_{CC})$$
 f is the frequency of the input signal; n is the number of device inputs at TTL levels; d is the duty cycle of the input signal; and C_L is the output load capacitance.
- 6/ This test is for qualification only. Ground and V_{CC} bounce tests are performed on a non-switching (quiescent) output and are used to measure the magnitude of induced noise caused by other simultaneously switching outputs. The test is performed on a low noise bench test fixture. For the device under test, all outputs shall be loaded with a minimum of 50 pF of load capacitance (see figure 4). Only chip capacitors shall be used. The output load components shall be located as close as possible to the device outputs. It is suggested, that whenever possible, this distance be kept to less than 0.25 inches. Decoupling capacitors shall be placed in parallel from V_{CC} to ground. The values of these decoupling capacitors shall be determined by the device manufacturer. The low and high level ground and V_{CC} bounce noise is measured at the quiet output using a 1 GHz minimum bandwidth oscilloscope with a 50 Ω input impedance.
- The device inputs shall be conditioned such that all outputs are at a high nominal V_{OH} level. The device inputs shall then be conditioned such that they switch simultaneously and the output under test remains at V_{OH} as all other outputs possible are switched from V_{OH} to V_{OL} . V_{OHV} and V_{OHP} are then measured from the nominal V_{OH} level to the largest negative and positive peaks, respectively (see figure 4). This is then repeated with the same outputs not under test switching from V_{OL} to V_{OH} .
- The device inputs shall be conditioned such that all outputs are at a low nominal V_{OL} level. The device inputs shall then be conditioned such that they switch simultaneously and the output under test remains at V_{OL} as all other outputs possible are switched from V_{OL} to V_{OH} . V_{OLP} and V_{OLV} are then measured from the nominal V_{OL} level to the largest positive and negative peaks, respectively (see figure 4). This is then repeated with the same outputs not under test switching from V_{OH} to V_{OL} .
- 7/ Tests shall be performed in sequence, attributes data only. Functional tests shall include the truth table and other logic patterns used for fault detection. The test vectors used to verify the truth table shall, at a minimum, test all functions of each input and output. All possible input to output logic patterns per function shall be guaranteed, if not tested, to the truth table in figure 2 herein. Functional tests shall be performed in sequence as approved by the qualifying activity on qualified devices. After incorporating allowable tolerances per MIL-STD-883, $V_{IL} = 0.4$ V and $V_{IH} = 2.4$ V. For outputs, $L \leq 0.8$ V, $H \geq 2.0$ V.
- 8/ For propagation delay tests, all paths must be tested.
- 9/ This parameter shall be guaranteed, if not tested, to the limits specified in table I, herein.

| | | | |
|---|-------------------|----------------|-------------------|
| STANDARD MICROCIRCUIT DRAWING DEFENSE SUPPLY CENTER COLUMBUS COLUMBUS, OHIO 43216-5000 | SIZE A | | 5962-96861 |
| | | REVISION LEVEL | SHEET 8 |

[查询"5962-9686101Q2A"供应商](#)

| Device type | 01 | |
|-----------------|-------------------|-------------------|
| Case outlines | C and D | 2 |
| Terminal number | Terminal symbol | |
| 1 | $\overline{1CLR}$ | NC |
| 2 | 1D | $\overline{1CLR}$ |
| 3 | 1CLK | 1D |
| 4 | $\overline{1PRE}$ | 1CLK |
| 5 | 1Q | NC |
| 6 | $\overline{1Q}$ | $\overline{1PRE}$ |
| 7 | GND | NC |
| 8 | $\overline{2Q}$ | 1Q |
| 9 | 2Q | $\overline{1Q}$ |
| 10 | $\overline{2PRE}$ | GND |
| 11 | 2CLK | NC |
| 12 | 2D | $\overline{2Q}$ |
| 13 | $\overline{2CLR}$ | 2Q |
| 14 | V _{CC} | $\overline{2PRE}$ |
| 15 | --- | NC |
| 16 | --- | 2CLK |
| 17 | --- | NC |
| 18 | --- | 2D |
| 19 | --- | $\overline{2CLR}$ |
| 20 | --- | V _{CC} |

NC = No connection

FIGURE 1. Terminal connections.

| | | | |
|---|-------------------|-----------------------|--------------------|
| STANDARD MICROCIRCUIT DRAWING DEFENSE SUPPLY CENTER COLUMBUS COLUMBUS, OHIO 43216-5000 | SIZE A | | 5962-96861 |
| | | REVISION LEVEL | SHEET 9 |

DESC FORM 193A
JUL 94

■ 9004708 0024742 8T2 ■

| Pin description | |
|--------------------------------|-----------------------|
| Terminal symbol | Description |
| mD (m = 1 to 2) | Data inputs |
| mQ (m = 1 to 2) | Non-inverting outputs |
| \overline{mQ} (m = 1 to 2) | Inverting outputs |
| \overline{mPRE} (m = 1 to 2) | Preset inputs |
| \overline{mCLR} (m = 1 to 2) | Clear inputs |
| mCLK (m = 1 to 2) | Clock inputs |

FIGURE 1. Terminal connections - Continued.

| Inputs | | | | Outputs | |
|-------------------|-------------------|------|----|-----------------|------------------|
| \overline{mPRE} | \overline{mCLR} | mCLK | mD | mQ | \overline{mQ} |
| L | H | X | X | H | L |
| H | L | X | X | L | H |
| L | L | X | X | H ^{1/} | H ^{1/} |
| H | H | ↑ | H | H | L |
| H | H | ↑ | L | L | H |
| H | H | L | X | Q ₀ | $\overline{Q_0}$ |

H = High voltage level

L = Low voltage level

X = Irrelevant

↑ = Low-to-high clock transition

Q₀ = The level of Q before the indicated steady-state input conditions were established

$\overline{Q_0}$ = The level of \overline{Q} before the indicated steady-state input conditions were established

^{1/} This configuration is nonstable; that is, it does not persist when \overline{mPRE} or \overline{mCLR} returns to its inactive (high) state.

FIGURE 2. Truth table.

| | | | |
|---|------------------|----------------|-------------|
| STANDARD MICROCIRCUIT DRAWING DEFENSE SUPPLY CENTER COLUMBUS COLUMBUS, OHIO 43216-5000 | SIZE A | | 5962-96861 |
| | | REVISION LEVEL | SHEET 10 |

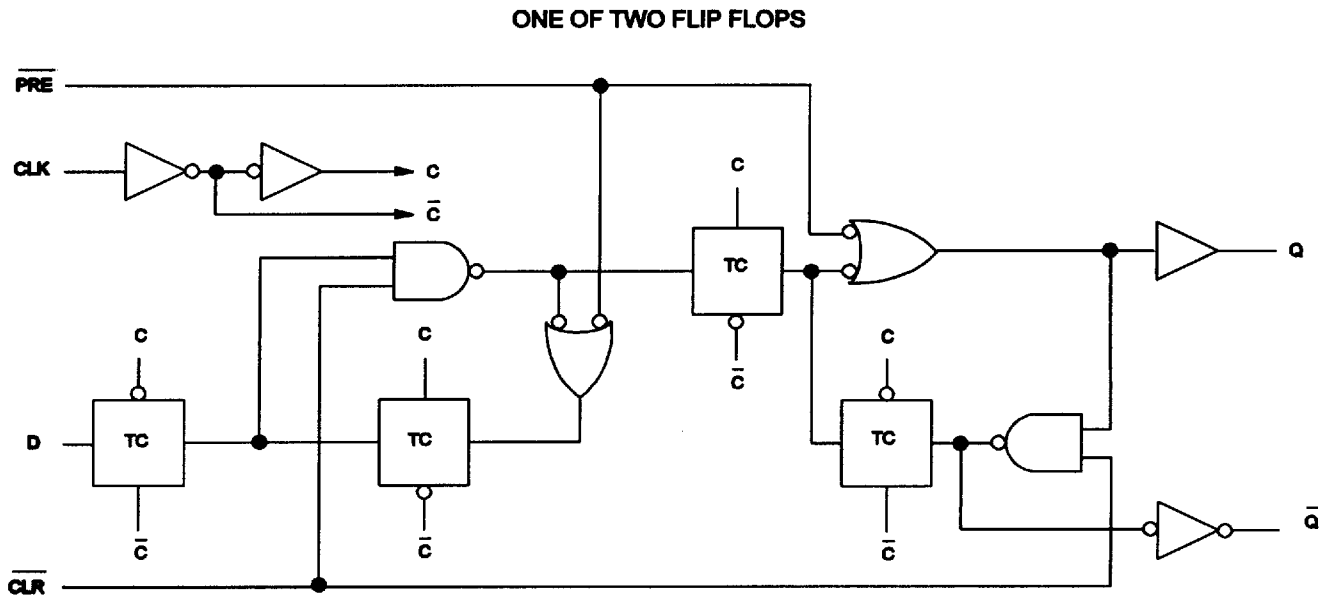
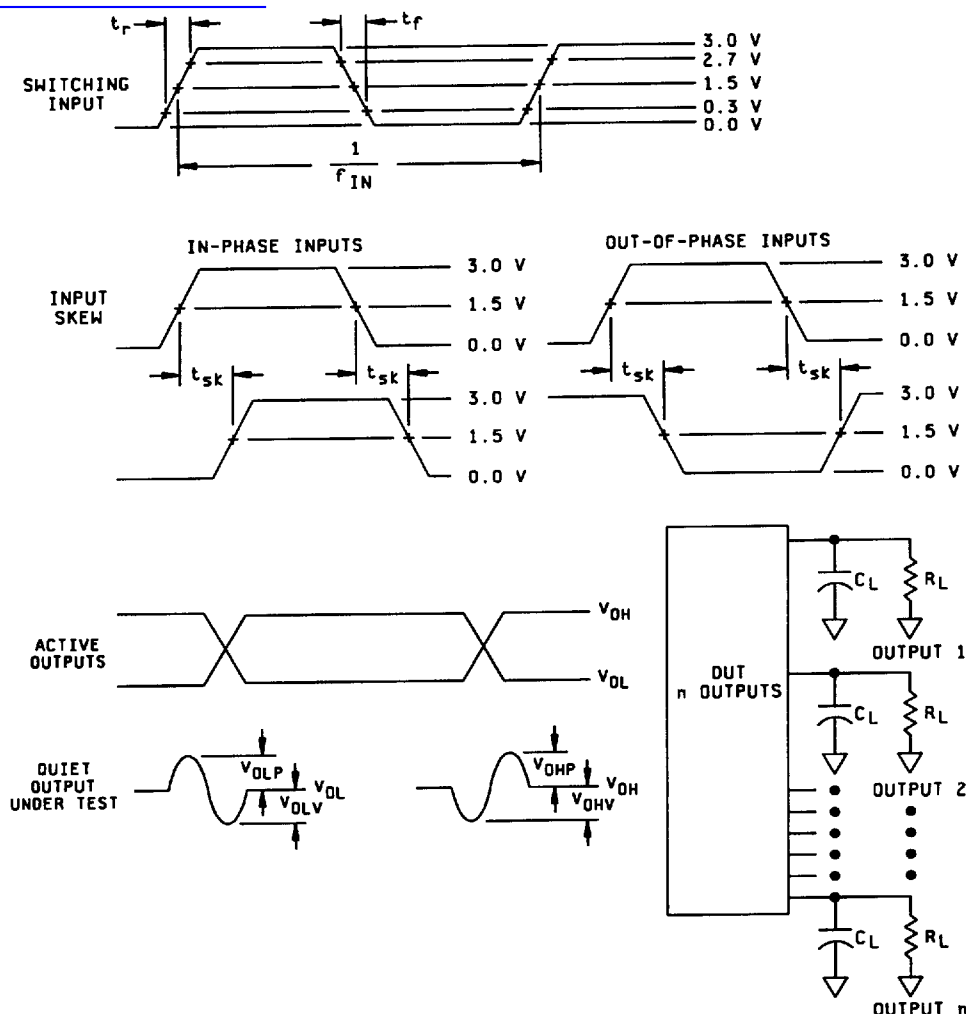

FIGURE 3. Logic diagram.

| | | | |
|---|------------------|----------------|-------------|
| STANDARD MICROCIRCUIT DRAWING DEFENSE SUPPLY CENTER COLUMBUS COLUMBUS, OHIO 43216-5000 | SIZE A | | 5962-96861 |
| | | REVISION LEVEL | SHEET 11 |

DESC FORM 193A
JUL 94

■ 9004708 0024744 675 ■



NOTES:

1. C_L includes a 47 pF chip capacitor (-0 percent, +20 percent) and at least 3 pF of equivalent capacitance from the test jig and probe.
2. $R_L = 5\text{ K}\Omega \pm 1\text{ percent}$, chip resistor in series with a 50 Ω termination. For monitored outputs, the 50 Ω termination shall be the 50 Ω characteristic impedance of the coaxial connector to the oscilloscope.
3. Input signal to the device under test:
 - a. $V_{IN} = 0.0\text{ V to } 3.0\text{ V}$; duty cycle = 50 percent; $f_{IN} \geq 1\text{ MHz}$.
 - b. $t_r, t_f = 3\text{ ns} \pm 1.0\text{ ns}$. For input signal generators incapable of maintaining these values of t_r and t_f , the 3.0 ns limit may be increased up to 10 ns, as needed, maintaining the $\pm 1.0\text{ ns}$ tolerance and guaranteeing the results at 3.0 ns $\pm 1.0\text{ ns}$; skew between any two switching inputs signals (t_{sk}): $\leq 250\text{ ps}$.

FIGURE 4. Ground bounce test circuit and waveforms.

| | | | |
|---|------------------|----------------|--------------------|
| STANDARD MICROCIRCUIT DRAWING DEFENSE SUPPLY CENTER COLUMBUS COLUMBUS, OHIO 43216-5000 | SIZE A | | 5962-96861 |
| | | REVISION LEVEL | SHEET 12 |

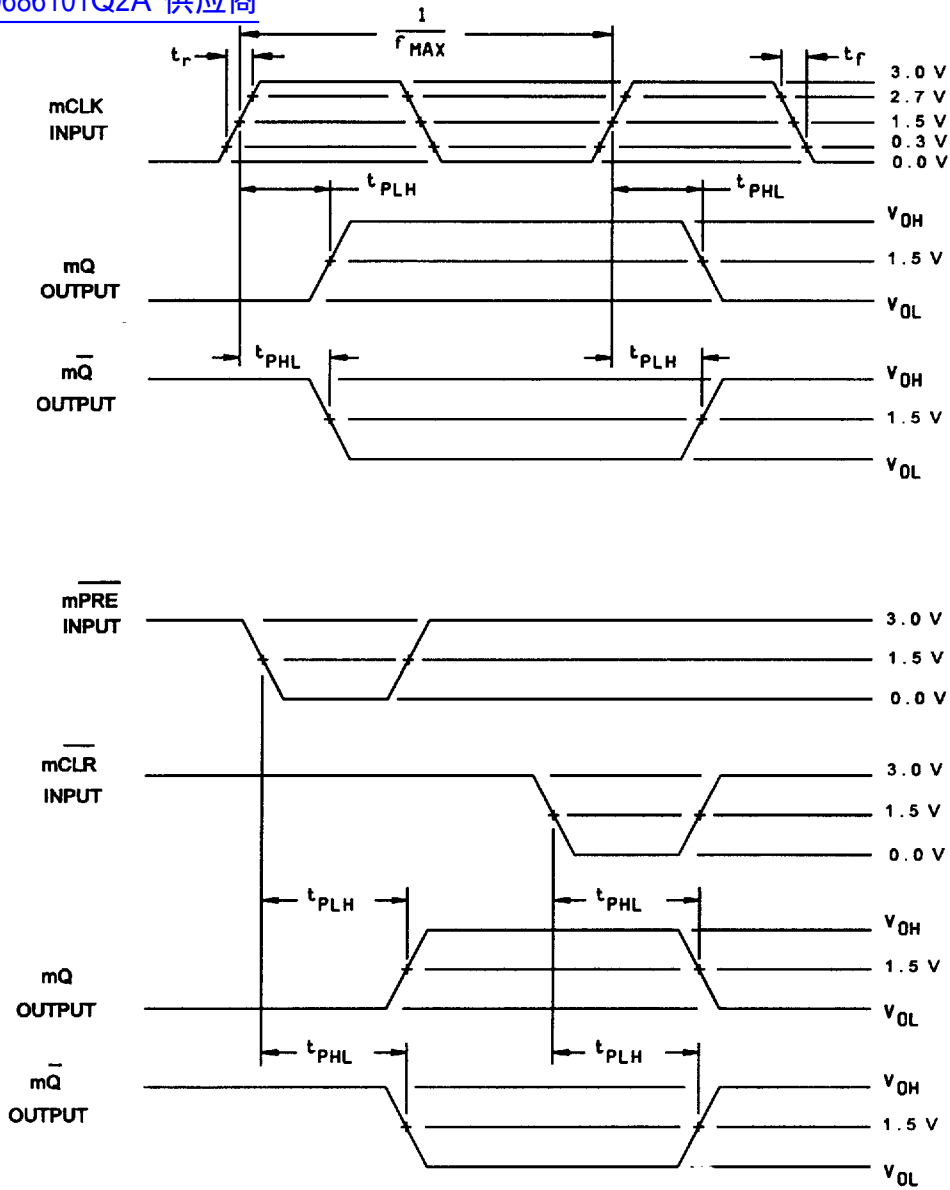
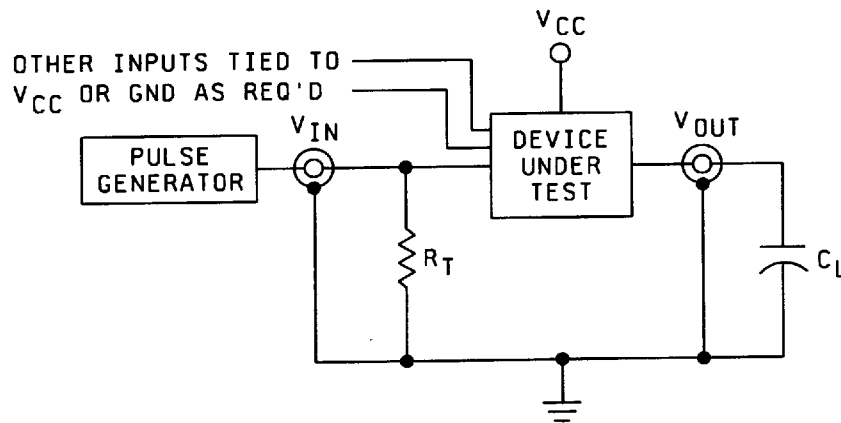
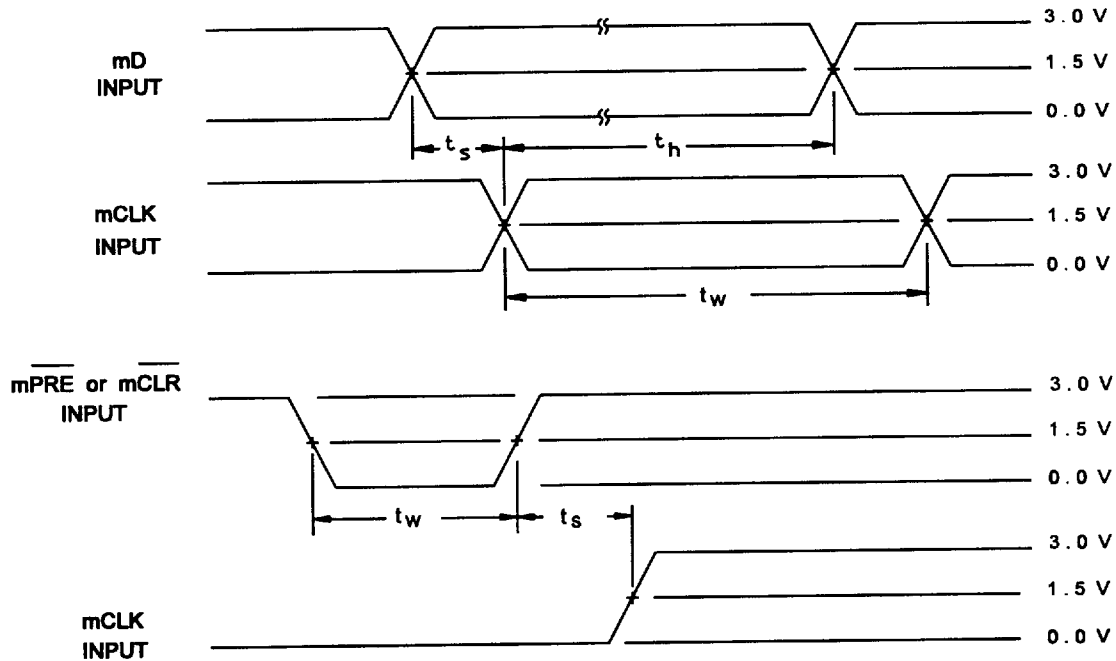

FIGURE 5. Switching waveforms and test circuit.

| | | | |
|---|------------------|----------------|--------------------|
| STANDARD MICROCIRCUIT DRAWING DEFENSE SUPPLY CENTER COLUMBUS COLUMBUS, OHIO 43216-5000 | SIZE A | | 5962-96861 |
| | | REVISION LEVEL | SHEET 13 |



NOTES:

1. C_L is per table I (includes test jig and probe capacitance).
2. $R_T = 50\Omega$ or equivalent.
3. Input signal from pulse generator: $V_{IN} = 0.0\text{ V to } 3.0\text{ V}$; $PRR \leq 1\text{ MHz}$; $t_r = 3.0\text{ ns}$; $t_f = 3.0\text{ ns}$; t_r and t_f shall be measured from 2.7 V to 0.3 V and from 0.3 V to 2.7 V, respectively; duty cycle = 50 percent.
4. Timing parameters shall be tested at a minimum input frequency of 1 MHz.
5. The outputs are measured one at a time with one transition per measurement.

FIGURE 5. Switching waveforms and test circuit - Continued.

| | | | |
|---|------------------|----------------|-------------|
| STANDARD MICROCIRCUIT DRAWING DEFENSE SUPPLY CENTER COLUMBUS COLUMBUS, OHIO 43216-5000 | SIZE A | | 5962-96861 |
| | | REVISION LEVEL | SHEET 14 |

4. QUALITY ASSURANCE PROVISIONS

4.1 Sampling and inspection. For device classes Q and V, sampling and inspection procedures shall be in accordance with MIL-PRF-38535 or as modified in the device manufacturer's Quality Management (QM) plan. The modification in the QM plan shall not affect the form, fit, or function as described herein. For device class M, sampling and inspection procedures shall be in accordance with MIL-PRF-38535, appendix A.

4.2 Screening. For device classes Q and V, screening shall be in accordance with MIL-PRF-38535, and shall be conducted on all devices prior to qualification and technology conformance inspection. For device class M, screening shall be in accordance with method 5004 of MIL-STD-883, and shall be conducted on all devices prior to quality conformance inspection.

4.2.1 Additional criteria for device class M.

- a. Burn-in test, method 1015 of MIL-STD-883.
 - (1) Test condition A, B, C, or D. The test circuit shall be maintained by the manufacturer under document revision level control and shall be made available to the preparing or acquiring activity upon request. The test circuit shall specify the inputs, outputs, biases, and power dissipation, as applicable, in accordance with the intent specified in test method 1015.
 - (2) $T_A = +125^\circ\text{C}$, minimum.
- b. Interim and final electrical test parameters shall be as specified in table II herein.

4.2.2 Additional criteria for device classes Q and V.

- a. The burn-in test duration, test condition and test temperature, or approved alternatives shall be as specified in the device manufacturer's QM plan in accordance with MIL-PRF-38535. The burn-in test circuit shall be maintained under document revision level control of the device manufacturer's Technology Review Board (TRB) in accordance with MIL-PRF-38535 and shall be made available to the acquiring or preparing activity upon request. The test circuit shall specify the inputs, outputs, biases, and power dissipation, as applicable, in accordance with the intent specified in test method 1015 of MIL-STD-883.
- b. Interim and final electrical test parameters shall be as specified in table II herein.
- c. Additional screening for device class V beyond the requirements of device class Q shall be as specified in MIL-PRF-38535, appendix B.

4.3 Qualification inspection for device classes Q and V. Qualification inspection for device classes Q and V shall be in accordance with MIL-PRF-38535. Inspections to be performed shall be those specified in MIL-PRF-38535 and herein for groups A, B, C, D, and E inspections (see 4.4.1 through 4.4.4).

4.3.1 Electrostatic discharge sensitivity qualification inspection. Electrostatic discharge sensitivity (ESDS) testing shall be performed in accordance with MIL-STD-883, method 3015. ESDS testing shall be measured only for initial qualification and after process or design changes which may affect ESDS classification.

4.4 Conformance inspection. Technology conformance inspection for classes Q and V shall be in accordance with MIL-PRF-38535 including groups A, B, C, D, and E inspections and as specified herein except where option 2 of MIL-PRF-38535 permits alternate in-line control testing. Quality conformance inspection for device class M shall be in accordance with MIL-PRF-38535, appendix A and as specified herein. Inspections to be performed for device class M shall be those specified in method 5005 of MIL-STD-883 and herein for groups A, B, C, D, and E inspections (see 4.4.1 through 4.4.4).

| | | | |
|---|------------------|----------------|--------------------|
| STANDARD MICROCIRCUIT DRAWING DEFENSE SUPPLY CENTER COLUMBUS COLUMBUS, OHIO 43216-5000 | SIZE A | | 5962-96861 |
| | | REVISION LEVEL | SHEET 15 |

TABLE II. Electrical test requirements.

查询"5962-968610Q2A"供应商

| Test requirements | Subgroups (in accordance with MIL-STD-883, method 5005, table I) | Subgroups (in accordance with MIL-PRF-38535, table III) | |
|--|---|---|--------------------------------|
| | Device class M | Device class Q | Device class V |
| Interim electrical parameters (see 4.2) | --- | --- | 1 |
| Final electrical parameters (see 4.2) | 1/ 1, 2, 3, 7, 8, 9, 10, 11 | 1/ 1, 2, 3, 7, 8, 9, 10, 11 | 2/ 1, 2, 3, 7, 8, 9, 10, 11 |
| Group A test requirements (see 4.4) | 1, 2, 3, 4, 7, 8, 9, 10, 11 | 1, 2, 3, 4, 7, 8, 9, 10, 11 | 1, 2, 3, 4, 7, 8, 9, 10, 11 |
| Group C end-point electrical parameters (see 4.4) | 1, 2, 3 | 1, 2, 3 | 1, 2, 3, 7, 8, 9, 10, 11 |
| Group D end-point electrical parameters (see 4.4) | 1, 2, 3 | 1, 2, 3 | 1, 2, 3 |
| Group E end-point electrical parameters (see 4.4) | 1, 7, 9 | 1, 7, 9 | 1, 7, 9 |

- 1/ PDA applies to subgroup 1.
2/ PDA applies to subgroups 1 and 7.

4.4.1 Group A inspection.

- a. Tests shall be as specified in table II herein.
- b. For device class M, subgroups 7 and 8 tests shall be sufficient to verify the truth table in figure 2 herein. The test vectors used to verify the truth table shall, at a minimum, test all functions of each input and output. All possible input to output logic patterns per function shall be guaranteed, if not tested, to the truth table in figure 2, herein. For device classes Q and V, subgroups 7 and 8 shall include verifying the functionality of the device; these tests shall have been fault graded in accordance with MIL-STD-883, test method 5012 (see 1.5 herein).
- c. C_{IN} and C_{PD} shall be measured only for initial qualification and after process or design changes which may affect capacitance. C_{IN} shall be measured between the designated terminal and GND at a frequency of 1 MHz. This test may be performed at 10 MHz and guaranteed, if not tested, at 1 MHz. C_{PD} shall be tested in accordance with the latest revision of JEDEC Standard No. 20 and table I herein. The DC bias for the pin under test (V_{BIAS}) = 2.5 V or 3.0 V. For C_{IN} and C_{PD} , test all applicable pins on five devices with zero failures.

For C_{IN} , a device manufacturer may qualify devices by functional groups. A specific functional group shall be composed of function types, that by design, will yield the same capacitance values when tested in accordance with table I, herein. The device manufacturer shall set a function group limit for the C_{IN} tests. The device manufacturer may then test one device functional group, to the limits and conditions specified herein. All other device functions in that particular functional group shall be guaranteed, if not tested, to the limits and test conditions specified in table I, herein. The device manufacturers shall submit to DSCC-VA the device functions listed in each functional group and the test results for each device tested.

| | | | |
|---|------------------|----------------|--------------------|
| STANDARD MICROCIRCUIT DRAWING DEFENSE SUPPLY CENTER COLUMBUS COLUMBUS, OHIO 43216-5000 | SIZE A | | 5962-96861 |
| | | REVISION LEVEL | SHEET 16 |

查询"5962-96861 024750"供应商

- d. Ground and V_{CC} bounce tests are required for all device classes. These tests shall be performed only for initial qualification, after process or design changes which may affect the performance of the device, and any changes to the test fixture. V_{OLP} , V_{OLV} , V_{OHP} , and V_{OHV} shall be measured for the worst case outputs of the device. All other outputs shall be guaranteed, if not tested, to the limits established for the worst case outputs. The worst case outputs tested are to be determined by the manufacturer. Test 5 devices assembled in the worst case package type supplied to this document. All other package types shall be guaranteed, if not tested, to the limits established for the worst case package. The 5 devices to be tested shall be the worst case device type supplied to this drawing. All other device types shall be guaranteed, if not tested, to the limits established for the worst case device type. The package type and device type to be tested shall be determined by the manufacturer. The device manufacturer will submit to DSCC-VA data that shall include all measured peak values for each device tested and detailed oscilloscope plots for each V_{OLP} , V_{OLV} , V_{OHP} , and V_{OHV} from one sample part per function. The plot shall contain the waveforms of both a switching output and the output under test.

Each device manufacturer shall test product on the fixtures they currently use. When a new fixture is used, the device manufacturer shall inform DSCC-VA of this change and test the 5 devices on both the new and old test fixtures. The device manufacturer shall then submit to DSCC-VA data from testing on both fixtures, that shall include all measured peak values for each device tested and detailed oscilloscope plots for each V_{OLP} , V_{OLV} , V_{OHP} , and V_{OHV} from one sample part per function. The plot shall contain the waveforms of both a switching output and the output under test.

For V_{OHP} , V_{OHV} , V_{OLP} , and V_{OLV} , a device manufacturer may qualify devices by functional groups. A specific functional group shall be composed of function types, that by design, will yield the same test values when tested in accordance with table I, herein. The device manufacturer shall set a functional group limit for the V_{OHP} , V_{OHV} , V_{OLP} , and V_{OLV} tests. The device manufacturer may then test one device function from a functional group, to the limits and conditions specified herein. All other device functions in that particular functional group shall be guaranteed, if not tested, to the limits and conditions specified in table I, herein. The device manufacturers shall submit to DSCC-VA the device functions listed in each functional group and test results, along with the oscilloscope plots, for each device tested.

4.4.2 Group C inspection. The group C inspection end-point electrical parameters shall be as specified in table II herein.

4.4.2.1 Additional criteria for device class M. Steady-state life test conditions, method 1005 of MIL-STD-883:

- a. Test condition A, B, C, or D. The test circuit shall be maintained by the manufacturer under document revision level control and shall be made available to the preparing or acquiring activity upon request. The test circuit shall specify the inputs, outputs, biases, and power dissipation, as applicable, in accordance with the intent specified in test method 1005 of MIL-STD-883.
- b. $T_A = +125^\circ\text{C}$, minimum.
- c. Test duration: 1,000 hours, except as permitted by method 1005 of MIL-STD-883.

4.4.2.2 Additional criteria for device classes Q and V. The steady-state life test duration, test condition and test temperature, or approved alternatives shall be as specified in the device manufacturer's QM plan in accordance with MIL-PRF-38535. The test circuit shall be maintained under document revision level control by the device manufacturer's TRB in accordance with MIL-PRF-38535 and shall be made available to the acquiring or preparing activity upon request. The test circuit shall specify the inputs, outputs, biases, and power dissipation, as applicable, in accordance with the intent specified in test method 1005 of MIL-STD-883.

4.4.3 Group D inspection. The group D inspection end-point electrical parameters shall be as specified in table II herein.

4.4.4 Group E inspection. Group E inspection is required only for parts intended to be marked as radiation hardness assured (see 3.5 herein).

- a. End-point electrical parameters shall be as specified in table II herein.
- b. For device classes Q and V, the devices or test vehicle shall be subjected to radiation hardness assured tests as specified in MIL-PRF-38535 for the RHA level being tested. For device class M, the devices shall be subjected to radiation hardness assured tests as specified in MIL-PRF-38535, appendix A for the RHA level being tested. All device classes must meet the postirradiation end-point electrical parameter limits as defined in table I at $T_A = +25^\circ\text{C} \pm 5^\circ\text{C}$, after exposure, to the subgroups specified in table II herein.

| | | | |
|---|-------------------|-----------------------|---------------------|
| STANDARD MICROCIRCUIT DRAWING DEFENSE SUPPLY CENTER COLUMBUS COLUMBUS, OHIO 43216-5000 | SIZE A | | 5962-96861 |
| | | REVISION LEVEL | SHEET 17 |

DESC FORM 193A
JUL 94

9004708 0024750 979

c. When specified in the purchase order or contract, a copy of the RHA delta limits shall be supplied.

4.5 Methods of inspection Methods of inspection shall be specified as follows:

4.5.1 Voltage and current. Unless otherwise specified, all voltages given are referenced to the microcircuit GND terminal. Currents given are conventional current and positive when flowing into the referenced terminal.

5. PACKAGING

5.1 Packaging requirements. The requirements for packaging shall be in accordance with MIL-PRF-38535 for device classes Q and V or MIL-PRF-38535, appendix A for device class M.

6. NOTES

6.1 Intended use. Microcircuits conforming to this drawing are intended for use for Government microcircuit applications (original equipment), design applications, and logistics purposes.

6.1.1 Replaceability. Microcircuits covered by this drawing will replace the same generic device covered by a contractor-prepared specification or drawing.

6.1.2 Substitutability. Device class Q devices will replace device class M devices.

6.2 Configuration control of SMD's. All proposed changes to existing SMD's will be coordinated with the users of record for the individual documents. This coordination will be accomplished in accordance with MIL-STD-973 using DD Form 1692, Engineering Change Proposal.

6.3 Record of users. Military and industrial users should inform Defense Supply Center, Columbus when a system application requires configuration control and which SMD's are applicable to that system. DSCC will maintain a record of users and this list will be used for coordination and distribution of changes to the drawings. Users of drawings covering microelectronic devices (FSC 5962) should contact DSCC-VA, telephone (614) 692-0674.

6.4 Comments. Comments on this drawing should be directed to DSCC-VA, Columbus, Ohio 43216-5000, or telephone (614) 692-0674.

6.5 Abbreviations, symbols, and definitions. The abbreviations, symbols, and definitions used herein are defined in MIL-PRF-38535 and MIL-HDBK-1331.

6.6 Sources of supply.

6.6.1 Sources of supply for device classes Q and V. Sources of supply for device classes Q and V are listed in QML-38535. The vendors listed in QML-38535 have submitted a certificate of compliance (see 3.6 herein) to DSCC-VA and have agreed to this drawing.

6.6.2 Approved sources of supply for device class M. Approved sources of supply for class M are listed in MIL-HDBK-103. The vendors listed in MIL-HDBK-103 have agreed to this drawing and a certificate of compliance (see 3.6 herein) has been submitted to and accepted by DSCC-VA.

| | | | |
|---|------------------|----------------|--------------------|
| STANDARD MICROCIRCUIT DRAWING DEFENSE SUPPLY CENTER COLUMBUS COLUMBUS, OHIO 43216-5000 | SIZE A | | 5962-96861 |
| | | REVISION LEVEL | SHEET 18 |

DESC FORM 193A
JUL 94

■ 9004708 0024751 805 ■

STANDARD MICROCIRCUIT DRAWING BULLETIN

DATE: 96-08-30

Approved sources of supply for SMD 5962-96861 are listed below for immediate acquisition information only and shall be added to MIL-HDBK-103 during the next revision. MIL-HDBK-103 will be revised to include the addition or deletion of sources. The vendors listed below have agreed to this drawing and a certificate of compliance has been submitted to and accepted by DSCC-VA. This bulletin is superseded by the next dated revision of MIL-HDBK-103.

| Standard microcircuit drawing PIN <u>1/</u> | Vendor CAGE number | Vendor similar PIN <u>2/</u> |
|---|--------------------|------------------------------|
| 5962-9686101QCA | 01295 | SNJ54AHCT74J |
| 5962-9686101QDA | 01295 | SNJ54AHCT74W |
| 5962-9686101Q2A | 01295 | SNJ54AHCT74FK |

- 1/ The lead finish shown for each PIN representing a hermetic package is the most readily available from the manufacturer listed for that part. The device manufacturers listed herein are authorized to supply alternate lead finishes "A", "B", or "C" at their discretion. Contact the listed approved source of supply for further information.
- 2/ **Caution.** Do not use this number for item acquisition. Items acquired to this number may not satisfy the performance requirements of this drawing.

Vendor CAGE number

01295

Vendor name and address

Texas Instruments Incorporated
13500 N. Central Expressway
P.O. Box 655303
Dallas, TX 75265
Point of contact: I-20 at FM 1788
Midland, TX 79711-0448

The information contained herein is disseminated for convenience only and the Government assumes no liability whatsoever for any inaccuracies in the information bulletin.