



T-51-10-90 LC²MOS
Complete 14-Bit, Sampling ADCs

AD7871/AD7872

FEATURES

- Complete Monolithic 14-Bit ADC
- 2s Complement Coding
- Parallel, Byte and Serial Digital Interface
- 80 dB SNR at 10 kHz Input Frequency
- 57 ns Data Access Time
- Low Power—50 mW typ
- 83 kSPS Throughput Rate
- 16-Lead SOIC (AD7872)

APPLICATIONS

- Digital Signal Processing
- High Speed Modems
- Speech Recognition and Synthesis
- Spectrum Analysis
- DSP Servo Control

GENERAL DESCRIPTION

The AD7871 and AD7872 are fast, complete, 14-bit analog-to-digital converters. They consist of a track/hold amplifier, successive-approximation ADC, 3 V buried Zener reference and versatile interface logic. The ADC features a self-contained, laser trimmed internal clock, so no external clock timing components are required. The on-chip clock may be overridden to synchronize ADC operation to the digital system for minimum noise.

The AD7871 offers a choice of three data output formats: a single, parallel, 14-bit word; two 8-bit bytes or a 14-bit serial data stream. The AD7872 is a serial output device only. The two parts are capable of interfacing to all modern microprocessors and digital signal processors.

The AD7871 and AD7872 operate from ±5 V power supplies, accept bipolar input signals of ±3 V and can convert full power signals up to 41.5 kHz.

In addition to the traditional dc accuracy specifications, the AD7871 and AD7872 are also fully specified for dynamic performance parameters including distortion and signal-to-noise ratio.

Both devices are fabricated in Analog Devices' LC²MOS mixed technology process. The AD7871 is available in 28-pin plastic DIP, hermetic DIP and PLCC packages. The AD7872 is available in 16-pin plastic and hermetic DIP packages or 16-lead SOIC.

FUNCTIONAL BLOCK DIAGRAMS

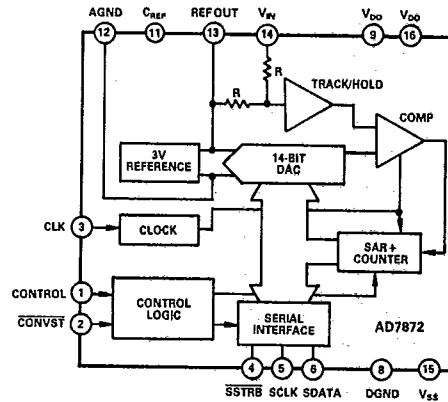
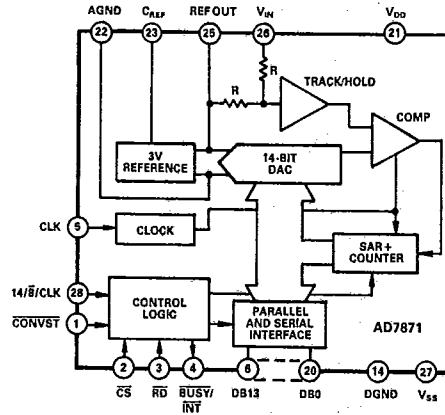

2

PRODUCT HIGHLIGHTS

1. Complete 14-Bit ADC on a Chip.
2. Dynamic Specifications for DSP Users.
3. Low Power.

($V_{DD} = +5\text{ V} \pm 5\%$, $V_{SS} = -5\text{ V} \pm 5\%$, $AGND = DGND = 0\text{ V}$, $f_{CLK} = 2\text{ MHz}$ external, $f_{SAMPLE} = 83\text{ kHz}$ unless otherwise stated.) All Specifications T_{min} to T_{max} unless otherwise noted.

AD7871/AD7872—SPECIFICATIONS

查询"AD7871AQ"供应商

Parameter	J, A Versions ¹	K, B Versions ¹	T Version ¹	Units	Test Conditions/Comments
T-51-10-90					
DYNAMIC PERFORMANCE²					
Signal to Noise Ratio ³ (SNR) @ +25°C	80	80	79	dB min	$V_{IN} = 10\text{ kHz}$ Sine Wave
T_{min} to T_{max}	80	80	79	dB min	SNR is Typically 82 dB for $<V_{IN} < 41.5\text{ kHz}$;
Total Harmonic Distortion (THD)	-86	-90		dB max	$V_{IN} = 10\text{ kHz}$ Sine Wave
Peak Harmonic or Spurious Noise	-86	-90	-85	dB typ	
			-85	dB max	$V_{IN} = 10\text{ kHz}$.
			-85	dB typ	
Intermodulation Distortion (IMD)				dB max	$f_a = 9\text{ kHz}$, $f_b = 9.5\text{ kHz}$, $f_{SAMPLE} = 50\text{ kHz}$
Second Order Terms	-86	-90	-85	dB typ	
Third Order Terms	-86	-90	-85	dB max	$f_a = 9\text{ kHz}$, $f_b = 9.5\text{ kHz}$, $f_{SAMPLE} = 50\text{ kHz}$
			-85	dB typ	
Track/Hold Acquisition Time	2	2	2	μs max	
DC ACCURACY					
Resolution	14	14	14	Bits	
Minimum Resolution for Which No Missing Codes Are Guaranteed	14	14	14	Bits	
Integral Nonlinearity @ +25°C		$\pm 1/2$	$\pm 1/2$	LSB typ	
Integral Nonlinearity		± 1	± 1	LSB max	
Bipolar Zero Error	± 12	± 12	± 12	LSB max	
Positive Gain Error ⁴	± 12	± 12	± 12	LSB max	
Negative Gain Error ⁴	± 12	± 12	± 12	LSB max	
ANALOG INPUT					
Input Voltage Range	± 3	± 3	± 3	Volts	
Input Current	± 500	± 500	± 500	μA max	
REFERENCE OUTPUT					
REF OUT @ +25°C	2.99/3.01	2.99/3.01	2.99/3.01	V min/V max	
T_{min} to T_{max}	2.98/3.02	2.98/3.02	2.98/3.02	V min/V max	
REF OUT Tempco		± 40	± 40	ppm/°C max	Typically 35 ppm
Reference Load Sensitivity ($\Delta\text{REF OUT}/\Delta I$)	± 1	± 1	± 1	mV max	Reference Load Current Change (0–500 μA); Reference Load Should Not Be Changed During Conversion
LOGIC INPUTS					
Input High Voltage, V_{INH}	2.4	2.4	2.4	V min	$V_{DD} = 5\text{ V} \pm 5\%$
Input Low Voltage, V_{INL}	0.8	0.8	0.8	V max	$V_{DD} = 5\text{ V} \pm 5\%$
Input Current, I_{IN}	± 10	± 10	± 10	μA max	$V_{IN} = 0\text{ V}$ to V_{DD}
Input Current (14/8/CLK Input Only)	± 10	± 10	± 10	μA max	$V_{IN} = V_{SS}$ to V_{DD}
Input Capacitance, C_{IN} ⁵	10	10	10	pF max	
LOGIC OUTPUTS					
Output High Voltage, V_{OH}	4.0	4.0	4.0	V min	$I_{SOURCE} = 40\text{ }\mu\text{A}$
Output Low Voltage, V_{OL}	0.4	0.4	0.4	V max	$I_{SINK} = 1.6\text{ mA}$
DB13 – DB0					
Floating-State Leakage Current	10	10	10	μA max	
Floating-State Output Capacitance ⁵	15	15	15	pF max	
CONVERSION TIME					
External Clock	10	10	10	μs max	
Internal Clock	10.5	10.5	10.5	μs max	The Internal Clock Has a Nominal Value of 2 MHz
POWER REQUIREMENTS					
V_{DD}	+5	+5	+5	V nom	$\pm 5\%$ for Specified Performance
V_{SS}	-5	-5	-5	V nom	$\pm 5\%$ for Specified Performance
I_{DD}	13	13	13	mA max	Typically 6 mA
I_{SS}	6	6	6	mA max	Typically 4 mA
Power Dissipation	95	95	95	mW max	Typically 50 mW

NOTES

¹Temperature ranges are as follows: J, K versions, 0°C to +70°C; A, B versions, -40°C to +85°C; T version; -55°C to +125°C.

² $V_{IN} = \pm 3\text{ V}$.

³SNR calculation includes distortion and noise components.

⁴Measured with respect to internal reference.

⁵Sample tested @ +25°C to ensure compliance.

Specifications subject to change without notice.

AD7871/AD7872

查询"AD7871AQ"供应商

TIMING CHARACTERISTICS^{1,2} ($V_{DD} = +5V \pm 5\%$, $V_{SS} = -5V \pm 5\%$, $AGND = DGND = 0V$. See Figures 9, 10, 11 and 12.)

Parameter	Limit at T_{min} , T_{max} (J, K, A, B Versions)	Limit at T_{min} , T_{max} (T Version)	Units	Conditions/Comments
t_1	50	50	ns min	CONVST Pulse Width
t_2	0	0	ns min	\overline{CS} to \overline{RD} Setup Time (Mode 1)
t_3	60	75	ns min	\overline{RD} Pulse Width
t_4	0	0	ns min	\overline{CS} to \overline{RD} Hold Time (Mode 1)
t_5	70	70	ns min	\overline{RD} to INT Delay
t_6^3	57	70	ns max	Data Access Time after \overline{RD}
t_7^4	5	5	ns min	Bus Relinquish Time after \overline{RD}
	50	50	ns max	
t_8	0	0	ns min	HBEN to \overline{RD} Setup Time
t_9	0	0	ns min	HBEN to \overline{RD} Hold Time
t_{10}^3	100	100	ns min	\overline{SSTRB} to SCLK Falling Edge Setup Time
t_{11}^6	440	440	ns min	SCLK Cycle Time
t_{12}^6	155	155	ns max	SCLK to Valid Data Delay, $C_L = 35\text{ pF}$
t_{13}	140	150	ns max	SCLK Rising Edge to \overline{SSTRB}
	20	20	ns min	
t_{14}	4	4	ns min	Bus Relinquish Time after SCLK
	100	100	ns max	
t_{15}	60	60	ns min	\overline{CS} to \overline{RD} Setup Time (Mode 2)
t_{16}^3	120	120	ns max	\overline{CS} to \overline{BUSY} Propagation Delay
t_{17}^3	200	200	ns min	Data Setup Time Prior to \overline{BUSY}
t_{18}	0	0	ns min	\overline{CS} to \overline{RD} Hold Time (Mode 2)
t_{19}	0	0	ns min	HBEN to \overline{CS} Setup Time
t_{20}	0	0	ns min	HBEN to \overline{CS} Hold Time

T-51-10-90

2

NOTES

- ¹Timing Specifications in bold print are 100% production tested. All other times are sample tested at +25°C to ensure compliance. All input signals are specified with $t_r = t_f = 5\text{ ns}$ (10% to 90% of 5 V) and timed from a voltage level of 1.6 V.
- ²Serial timing is measured with a 4.7 k Ω pull-up resistor on SDATA and \overline{SSTRB} and a 2 k Ω pull-up resistor on SCLK. The capacitance on all three outputs is 35 pF.
- ³ t_6 and t_{17} are measured with the load circuits of Figure 1 and defined as the time required for an output to cross 0.8 V or 2.4 V.
- ⁴ t_7 is derived from the measured time taken by the data outputs to change 0.5 V when loaded with the circuit of Figure 2. The measured number is then extrapolated back to remove the effects of charging or discharging the 50 pF capacitor. This means that the time, t_7 , quoted in the Timing Characteristics is the true bus relinquish time of the part and is independent of bus loading.
- ⁵SCLK mark/space ratio (measured from a voltage level of 1.6 V) is 40/60 to 60/40.
- ⁶SDATA will drive higher capacitive loads, but this will add to t_{12} since it increases the external RC time constant (4.7 k Ω /C_L) and hence the time to reach 2.4 V. Specifications subject to change without notice.

ABSOLUTE MAXIMUM RATINGS*

- V_{DD} to AGND -0.3 V to +7 V
- V_{SS} to AGND +0.3 V to -7 V
- AGND to DGND -0.3 V to $V_{DD} + 0.3\text{ V}$
- V_{IN} to AGND $V_{SS} - 0.3\text{ V}$ to $V_{DD} + 0.3\text{ V}$
- REF OUT, C_{REF} to AGND 0 V to V_{DD}
- Digital Inputs to DGND -0.3 V to $V_{DD} + 0.3\text{ V}$
- Digital Outputs to DGND -0.3 V to $V_{DD} + 0.3\text{ V}$
- Operating Temperature Range
 - Commercial (J, K Versions) 0°C to +70°C
 - Industrial (A, B Versions) -40°C to +85°C
 - Extended (T Version) -55°C to +125°C
- Storage Temperature Range -65°C to +150°C
- Lead Temperature (Soldering, 10 secs) +300°C
- Power Dissipation (Any Package) to +75°C 450 mW
- Derates above +75°C by 6 mW/°C

*Stresses above those listed under "Absolute Maximum Ratings" may cause permanent damage to the device. This is a stress rating only and functional operation of the device at these or any other conditions above those listed in the operational sections of this specification is not implied. Exposure to absolute maximum rating conditions for extended periods may affect device reliability.

CAUTION

ESD (electrostatic discharge) sensitive device. The digital control inputs are diode protected; however, permanent damage may occur on unconnected devices subject to high energy electrostatic fields. Unused devices must be stored in conductive foam or shunts. The protective foam should be discharged to the destination socket before devices are inserted.

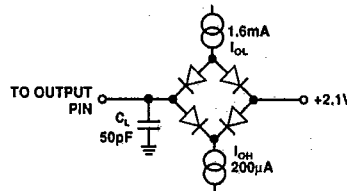

Figure 1. Load Circuit for Access Time

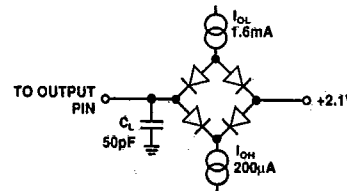

Figure 2. Load Circuit for Output Float Delay

AD7871/AD7872

查询"AD7871AQ"供应商

AD7871 PIN FUNCTION DESCRIPTION

DIP

No.	Mnemonic	Function
1	$\overline{\text{CONVST}}$	Convert Start. A low to high transition on this input puts the track/hold into the hold mode. This input is asynchronous to the CLK. $\overline{\text{CS}}$ and $\overline{\text{RD}}$ must be held high for the duration of this pulse.
2	$\overline{\text{CS}}$	Chip Select. Active low logic input. The device is selected when this input is active. With $\overline{\text{CONVST}}$ tied low, a new conversion is initiated when $\overline{\text{CS}}$ goes low.
3	$\overline{\text{RD}}$	Read. Active low logic input. This input is used in conjunction with $\overline{\text{CS}}$ low to enable the data outputs.
4	BUSY/INT	Busy/Interrupt. Logic low output indicating converter status. See timing diagrams.
5	CLK	Clock Input. An external TTL-compatible clock may be applied to this input. Alternatively, tying this pin to V_{SS} enables the internal laser-trimmed oscillator.
6	DB13/HBEN	Data Bit 13 (MSB)/High Byte Enable. The function of this pin is dependent on the state of the $14/\overline{8}/\text{CLK}$ input (see Pin 28). When 14-bit data is selected, this pin provides the DB13 output. When either byte or serial data is selected, this pin becomes the HBEN logic input. HBEN is used for 8-bit bus interfacing. When HBEN is low, DB7 to DB0 is the lower byte of data. With HBEN high, DB7 to DB0 is the upper byte of data (see Table I).

HBEN	DB7	DB6	DB5	DB4	DB3	DB2	DB1	DB0
HIGH	LOW	LOW	DB13	DB12	DB11	DB10	DB9	DB8
LOW	DB7	DB6	DB5	DB4	DB3	DB2	DB1	DB0

Table I. Byte Output Format

7	DB12/ $\overline{\text{SSTRB}}$	Data Bit 12/Serial Strobe. When 14-bit data is selected, this pin provides the DB12 data output. Otherwise it is an active low three-state output which provides a framing pulse for serial data.
8	DB11/SCLK	Data Bit 11/Serial Clock. When 14-bit data is selected, this pin provides the DB11 data output. Otherwise SCLK is the gated serial clock output which is derived from the internal or external ADC clock. If the $14/\overline{8}/\text{CLK}$ input is held at -5 V , then the SCLK runs continuously. With $14/\overline{8}/\text{CLK}$ at 0V , it is gated off (three-state) after serial transmission is complete.
9	DB10/SDATA	Data Bit 10/Serial Data. When 14-bit parallel data is selected, this pin provides the DB10 data output. Otherwise it is the three-state serial data output used in conjunction with SCLK and $\overline{\text{SSTRB}}$ in serial data transmission. Serial data is valid on the falling edge of SCLK, when $\overline{\text{SSTRB}}$ is low.
10-13	DB9-DB6	Three-State Data Outputs which are controlled by $\overline{\text{CS}}$ and $\overline{\text{RD}}$. Their function depends on the state of the $14/\overline{8}/\text{CLK}$ and the HBEN inputs. With $14/\overline{8}/\text{CLK}$ high, they are always DB9-DB6. With $14/\overline{8}/\text{CLK}$ low, their function depends on HBEN (see Table I).
14	DGND	Digital Ground. Ground return for digital circuitry.
15-20	DB5/DB13-DB0/DB8	Three-State Data Outputs which are controlled by $\overline{\text{CS}}$ and $\overline{\text{RD}}$. Their function depends on the $14/\overline{8}/\text{CLK}$ and HBEN inputs. With $14/\overline{8}/\text{CLK}$ high, they are always DB5-DB0. With $14/\overline{8}/\text{CLK}$ low or -5 V , their function is controlled by HBEN (see Table I).
21	V_{DD}	Positive Supply, $+5\text{ V} \pm 5\%$.
22	AGND	Analog Ground. Ground reference for analog circuitry.
23	C_{REF}	Decoupling point for on-chip reference. Connect 10 nF between this pin and AGND.
24	NC	No Connect.
25	REF OUT	Voltage Reference Output. The internal 3 V reference is provided at this pin. The external load capability is $500\text{ }\mu\text{A}$.
26	V_{IN}	Analog Input. The input range is $\pm 3\text{ V}$.
27	V_{SS}	Negative Supply, $-5\text{ V} \pm 5\%$.
28	$14/\overline{8}/\text{CLK}$	Three-Function Input. Defines both the parallel and serial data formats. With this pin at $+5\text{ V}$, the output data is 14-bit parallel only. With this pin at 0 V , both byte and serial data are available, and the SCLK is noncontinuous. With this pin at -5 V , both byte and serial data are available and the SCLK is continuous.

[查询"AD7871AQ"供应商](#)

AD7871/AD7872

AD7872 PIN FUNCTION DESCRIPTION

T-51-10-90

DIP No.	Mnemonic	Function
1	CONTROL	Control Input. With this pin at 0 V, the SCLK is noncontinuous. With this pin at -5 V, the SCLK is continuous.
2	CONVST	Convert Start. A low to high transition on this input puts the track/hold into the hold mode. This input is asynchronous to the CLK.
3	CLK	Clock Input. An external TTL-compatible clock may be applied to this input. Alternatively, tying this pin to V _{SS} , enables the internal laser-trimmed oscillator.
4	SSTRB	This is an active low three-state output which provides a framing pulse for serial data. An external 4.7 kΩ pull-up resistor is required on SSTRB.
5	SCLK	Serial Clock. SCLK is the gated serial clock output which is derived from the internal or external ADC clock. If the 14/8/CLK input is at -5 V, then the SCLK runs continuously. With CONTROL at 0 V, it is gated off (three-state) after serial transmission is complete. SCLK is an open-drain output and requires an external 2 kΩ pull-up resistor.
6	SDATA	Serial Data. This is the three-state serial data output used in conjunction with SCLK and SSTRB in serial data transmission. Serial data is valid on the falling edge of SCLK, when SSTRB is low. An external 4.7 kΩ pull-up resistor is required on SDATA.
7	NC	No Connect.
8	DGND	Digital Ground. Ground return for digital circuitry.
9	V _{DD}	Positive Supply for analog circuitry, +5 V ± 5%.
10	NC	No Connect.
11	C _{REF}	Decoupling point for on-chip reference. Connect 10 nF capacitor between this pin and AGND.
12	AGND	Analog Ground. Ground reference for analog circuitry.
13	REF OUT	Voltage Reference Output. The internal 3 V reference is provided at this pin. The external load capability is 500 μA.
14	V _{IN}	Analog Input. The input range is ±3 V.
15	V _{SS}	Negative Supply, -5 V ± 5%.
16	V _{DD}	Positive Supply for analog circuitry, +5 V ± 5%. Pin 16 and Pin 9 should be connected together.

2

PIN CONFIGURATIONS

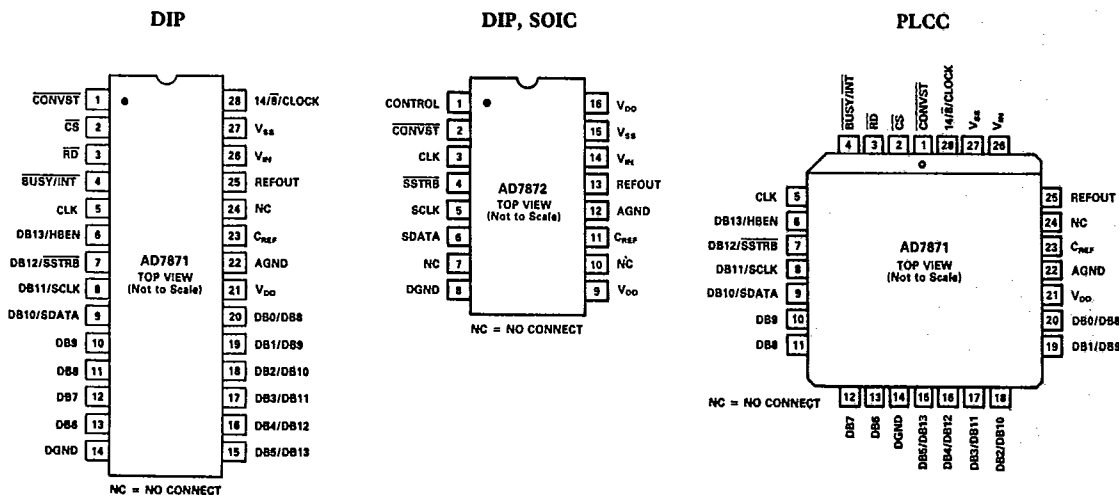

T-51-10-90

AD7871/AD7872

查询"AD7871AQ"供应商

CONVERTER DETAILS

The AD7871/AD7872 is a complete 14-bit A/D converter, requiring no external components apart from power supply decoupling capacitors. It is comprised of a 14-bit successive approximation ADC based on a fast settling voltage-output DAC, a high speed comparator and CMOS SAR, a track/hold amplifier, a 3 V buried Zener reference, a clock oscillator and control logic.

INTERNAL REFERENCE

The AD7871/AD7872 has an on-chip temperature compensated buried Zener reference which is factory trimmed to 3 V \pm 10 mV. Internally it provides both the DAC reference and the dc bias required for bipolar operation. Reference noise is minimized by connecting a capacitor between C_{REF} and AGND. For specified operation this capacitor should be 10 nF. The reference output is available (REF OUT) and is capable of providing up to 500 μ A to an external load.

The maximum recommended capacitance on REF OUT for normal operation is 50 pF. If the reference is required for use external to the AD7871/AD7872, it should be decoupled with a 200 Ω resistor in series with a parallel combination of a 10 μ F tantalum capacitor and a 0.1 μ F ceramic capacitor. These decoupling components are required to remove voltage spikes caused by the AD7871/AD7872's internal operation.

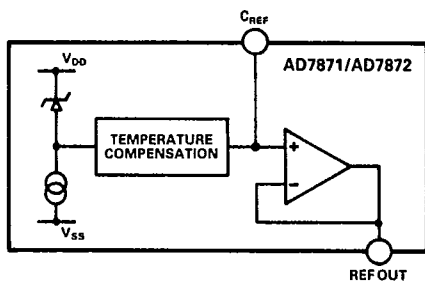

Figure 3. AD7871/AD7872 Reference Circuit

TRACK-AND-HOLD AMPLIFIER

The track-and-hold amplifier on the analog input of the AD7871/AD7872 allows the ADC to accurately convert an input sine wave of 6 V peak-peak amplitude to 14-bit accuracy. The input bandwidth of the track/hold amplifier is much greater than the Nyquist rate of the ADC even when the ADC is operated at its maximum throughput rate. The 0.1 dB cutoff frequency occurs typically at 500 kHz. The track/hold amplifier acquires an input signal to 14-bit accuracy in less than 2 μ s. The overall throughput rate is determined by the conversion time plus the track/hold amplifier acquisition time. For a 2 MHz input clock the throughput time is 12 μ s maximum.

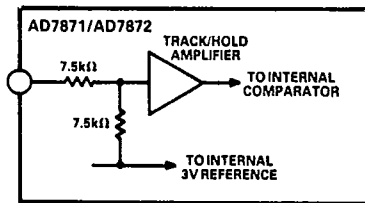

Figure 4. AD7871/AD7872 Analog Input

The operation of the track/hold amplifier is essentially transparent to the user. The track/hold amplifier goes from its tracking mode to its hold mode at the start of conversion. If the CONVST input is used to start conversion, then the track to hold transition occurs on the rising edge of CONVST. If \overline{CS} on the AD7871 starts conversion, this transition occurs on the falling edge of \overline{CS} .

ANALOG INPUT

Figure 4 shows the AD7871/AD7872 analog input. The analog input range is \pm 3 V into an input resistance of typically 15 k Ω . The designed code transitions occur midway between successive integer LSB values (i.e., 1/2 LSB, 3/2 LSBs, 5/2 LSBs . . . FS - 3/2 LSBs). The output code is 2s complement binary with 1 LSB = $FS/16384 = 6\text{ V}/16384 = 366\ \mu\text{V}$. The ideal input/output transfer function is shown in Figure 5.

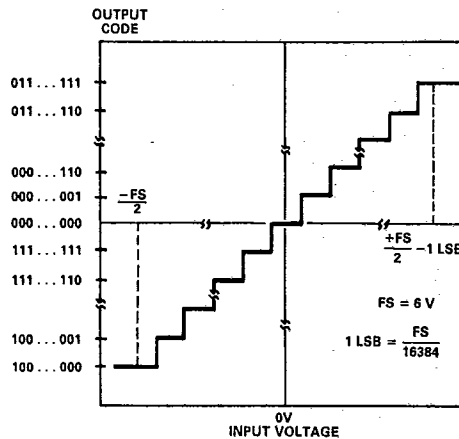
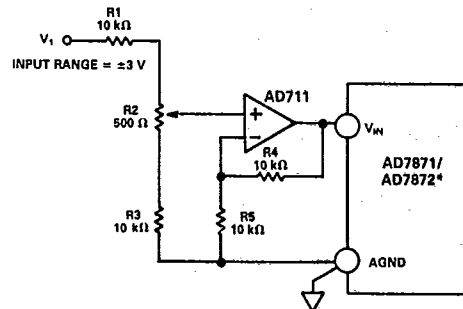

Figure 5. Bipolar Input/Output Transfer Function

BIPOLAR OFFSET AND FULL-SCALE ADJUSTMENT

When the AD7871/AD7872's offset and full-scale errors need to be adjusted, offset error must be adjusted first. This is achieved by trimming the offset of the op amp driving the analog input of the AD7871/AD7872 while the input voltage is 1/2 LSB below AGND. The trim procedure is as follows: apply a voltage of -0.183 mV (-1/2 LSB) at V_1 in Figure 6 and adjust the op-amp offset voltage until the ADC output code flickers between 11 1111 1111 1111 and 00 0000 0000 0000.



*ADDITIONAL PINS OMITTED FOR CLARITY

Figure 6. Bipolar Adjust Circuit

[查询"AD7871AQ"供应商](#)

AD7871/AD7872

Gain error can be adjusted at either the first code transition (ADC negative full scale) or the last code transition (ADC positive full scale). The trim procedures for both cases are as follows (see Figure 6).

Positive Full-Scale Adjust

Apply a voltage of 2.9995 V (FS/2 - 3/2 LSBs) at V_1 and adjust R2 until the ADC output code flickers between 01 1111 1111 1110 and 01 1111 1111 1111.

Negative Full-Scale Adjust

Apply a voltage of -2.9998 V (-FS/2 + 1/2 LSB) at V_1 and adjust R2 until the ADC output code flickers between 10 0000 0000 0000 and 10 0000 0000 0001.

UNIPOLAR OPERATION

A typical unipolar circuit is shown in Figure 7. The AD7871/AD7872 REF OUT is used to offset the analog input by 3 V. The analog input range is determined by the ratio of R3 to R4. The minimum range with which the circuit will work is 0 to +3 V. The resistor values are given in Figure 7 for input ranges of 0 to +5 V and 0 to +10 V. R5 and R6 are included for offset and full scale adjust only and should be omitted if adjustment is not required.

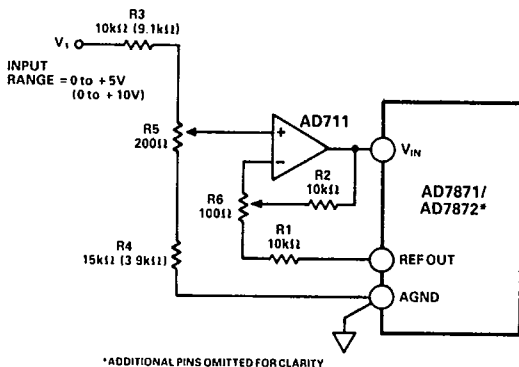

Figure 7. AD7871/AD7872 Unipolar Circuit

The ideal input/output transfer function is shown in Figure 8. The output can be converted to straight binary by inverting the MSB.

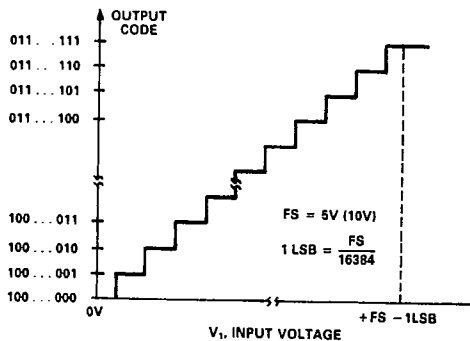

Figure 8. Unipolar Transfer Function

UNIPOLAR OFFSET AND FULL-SCALE ADJUSTMENT

When absolute accuracy is required, offset and full-scale error can be adjusted to zero. Offset must be adjusted before full-scale. This is achieved by applying an input voltage of (1/2 LSB) to V_1 and adjust R6 until the ADC output code flickers between 10 0000 0000 0000 and 10 0000 0000 0001. For full-scale adjustment apply an input voltage of (FS - 3/2 LSBs) to V_1 and adjust R5 until the output code flickers between 01 1111 1111 1110 and 01 1111 1111 1111.

T-51-10-90

2

TIMING AND CONTROL

The conversion time for both external and internal clock can vary from 19 to 20 rising clock edges depending on the conversion start to ADC clock synchronization. If a conversion is initiated within 30 ns prior to a rising edge of the ADC clock, the conversion time will consist of 20 rising clock edges.

There are two basic operating modes for the AD7871. In the first mode (Mode 1) the CONVST line is used to start conversion and drive the track/hold into its hold mode. At the end of conversion, the track/hold returns to its tracking mode. It is intended principally for digital signal processing and other applications where precise sampling in time is required. In these applications, it is important that the signal sampling occurs at exactly equal intervals to minimize errors due to sampling uncertainty or jitter. For these cases, the CONVST line is driven by a timer or some precise clock source.

The second mode is achieved by hard-wiring the CONVST line low. This mode (Mode 2) is intended for use in systems where the microprocessor has total control of the ADC, both initiating the conversion and reading the data. CS and RD start conversion, and the microprocessor will normally be driven into a WAIT state for the duration of conversion by BUSY/INT.

The AD7872 has one operating mode only. This is Mode 1, described above, which uses CONVST to start conversion.

DATA OUTPUT FORMATS

The AD7871 offers a choice of three data output formats, one serial and two parallel. The parallel data formats include a single 14-bit parallel word for 16-bit data buses and a two-byte format for 8-bit data buses. The data format is controlled by the 14/8/CLK input. A logic high on this pin selects the 14-bit parallel output format only. A logic low or -5 V applied to this pin allows the user access to either serial or byte formatted data. Three of the pins previously assigned to the four MSBs in parallel form are now used for serial communications while the fourth pin becomes a control input for the byte-formatted data. The three possible data output formats can be selected in either of the modes of operation.

The AD7872 is a serial output device only. The serial data format is exactly the same as the AD7871.

Parallel Output Format

The two parallel formats available on the AD7871 are a 14-bit wide data word and a two-byte data word. In the first, all 14 bits of data are available at the same time on DB13 (MSB) through DB0 (LSB). In the second, two reads are required to access the data. When this data format is selected, the DB13/HBEN pin assumes the HBEN function. HBEN selects which byte of data is to be read from the AD7871. When HBEN is low, the lower 8 bits of data are placed on the data bus during a read operation; with HBEN high, the upper 6 bits

AD7871/AD7872

[查询 AD7871AQ"供应商"](#)

T-51-10-90

of the 14-bit word are placed on the data bus. These 6 bits are right justified and thereby occupy the lower six bits of the byte while the upper two bits are zeros.

Serial Output Format

Serial data is available on the AD7871 when the $14/\overline{\text{CLK}}$ input is at 0 V or -5 V and in this case the DB12/ $\overline{\text{SSTRB}}$, DB11/ $\overline{\text{SCLK}}$ and DB10/ $\overline{\text{SDATA}}$ pins assume their serial functions. The AD7872 is a serial output device only. The serial function on both devices is identical. Serial data is available during conversion with a word length of 16 bits; 2 leading zeros, followed by the 14-bit conversion result starting with the MSB. The data is synchronized to the serial clock output (SCLK) and is framed by the serial strobe ($\overline{\text{SSTRB}}$). Data is clocked out on a low to high transition of the serial clock and is valid on the falling edge of this clock while the $\overline{\text{SSTRB}}$ output is low. $\overline{\text{SSTRB}}$ goes low at the start of conversion and the first serial data bit (which is the first leading zero) is valid on the first falling edge of SCLK. All the serial lines are open-drain outputs and require external pull-up resistors.

The serial clock out is derived from the ADC master clock source which may be internal or external. Normally, SCLK is required during the serial transmission only. In these cases it can be shut down (i.e., placed into three-state) at the end of conversion to allow multiple ADCs to share a common serial bus. However, some serial systems (e.g., TMS32020) require a serial clock which runs continuously. Both options are available on the AD7871 and AD7872. With the $14/\overline{\text{CLK}}$ input on the AD7871 at -5 V, the serial clock (SCLK) runs continuously; when $14/\overline{\text{CLK}}$ is at 0 V, SCLK goes into three-state at the end of transmission. The CONTROL pin on the AD7872 performs the same function. When this is at 0 V, SCLK is noncontinuous and when it is at -5 V, SCLK is continuous.

The SCLK, $\overline{\text{SDATA}}$ and $\overline{\text{SSTRB}}$ lines are open-drain outputs. If these are required to drive capacitive loads in excess of 35 pF, buffering is recommended.

MODE 1 INTERFACE

Conversion is initiated by a low going pulse on the $\overline{\text{CONVST}}$ input. The rising edge of this $\overline{\text{CONVST}}$ pulse starts conversion and drives the track/hold amplifier into its hold mode. The $\overline{\text{BUSY}}/\overline{\text{INT}}$ status output assumes its $\overline{\text{INT}}$ function in this mode. $\overline{\text{INT}}$ is normally high and goes low at the end of conversion. This $\overline{\text{INT}}$ line can be used to interrupt the microprocessor. A read operation to the AD7871 accesses the data and the $\overline{\text{INT}}$ line is reset high on the falling edge of $\overline{\text{CS}}$ and $\overline{\text{RD}}$. The $\overline{\text{CONVST}}$ input must be high when $\overline{\text{CS}}$ and $\overline{\text{RD}}$ are brought low for the AD7871 to operate correctly in this mode. It is important, especially in systems where the conversion start ($\overline{\text{CONVST}}$) pulse is asynchronous to the microprocessor, to ensure that a parallel or byte data read is not attempted during a conversion. Trying to read data during a conversion can cause errors to the conversion in progress. Avoid pulsing the $\overline{\text{CONVST}}$ line a second time before conversion end since it can cause errors in the conversion result. In applications where precise sampling is not critical, the $\overline{\text{CONVST}}$ pulse can be generated from microprocessor $\overline{\text{WR}}$ line OR-gated with the AD7871 $\overline{\text{CS}}$ input. In some applications, depending on power supply turn-on time, the AD7871/AD7872 may perform a conversion on power-up. In this case, the $\overline{\text{INT}}$ line on the AD7871 will power up low, and a dummy read to the device will be required to reset the $\overline{\text{INT}}$ line before starting conversion.

Figure 9 shows the Mode 1 timing diagram for a 14-bit parallel data output format ($14/\overline{\text{CLK}} = +5 \text{ V}$). A read to the AD7871 at the end of conversion accesses all 14 bits of data at the same time. Serial data is not available for this data output format.

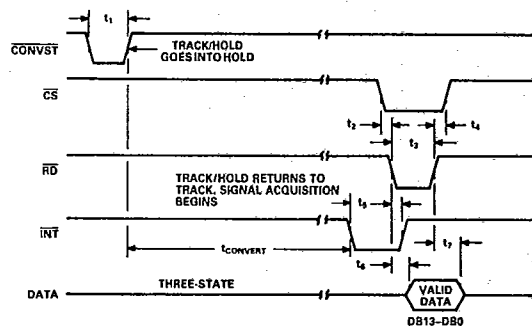

Figure 9. Mode 1 Timing Diagram, 14-Bit Parallel Read

The Mode 1 function timing diagram for byte and serial data is shown in Figure 10. $\overline{\text{INT}}$ goes low at the end of conversion and is reset high by the first falling edge of $\overline{\text{CS}}$ and $\overline{\text{RD}}$. This first read at the end of conversion can either access the low-byte or high byte of data depending on the status of HBEN (Figure 10 shows low byte for example only). The diagram shows both the SCLK output going into three-state at the end of transmission and a continuously running clock (dashed line).

MODE 2 INTERFACE

The second interface mode is achieved by hard-wiring $\overline{\text{CONVST}}$ low and conversion is initiated by taking $\overline{\text{CS}}$ low while HBEN is low. The track/hold amplifier goes into the hold mode on the falling edge of $\overline{\text{CS}}$. In this mode the $\overline{\text{BUSY}}/\overline{\text{INT}}$ pin assumes its $\overline{\text{BUSY}}$ function. $\overline{\text{BUSY}}$ goes low at the start of conversion, stays low during the conversion and returns high when the conversion is complete. It is normally used in parallel interfaces to drive the microprocessor into a WAIT state for the duration of conversion.

Figure 11 shows the Mode 2 timing diagram for the 14-bit parallel data output format ($14/\overline{\text{CLK}} = +5 \text{ V}$). In this case the ADC behaves like slow memory. The major advantage of this interface is that it allows the microprocessor to start conversion, WAIT and then read data with a single READ instruction. The user does not have to worry about servicing interrupts or ensuring that software delays are long enough to avoid the reading during conversion.

The Mode 2 timing diagram for byte and serial data is shown in Figure 12. For two-byte data read, the lower byte (DB0-DB7) has to be accessed first since HBEN must be low to start conversion. The ADC behaves like slow memory for this first read, but the second read to access the upper byte of data is a normal read. Operation to the serial functions is identical between Mode 1 and Mode 2. Once again, the timing diagram of Figure 12 shows SCLK going into three-state or running continuously (dashed line).

[查询"AD7871AQ"供应商](#)

AD7871/AD7872

T-51-10-90

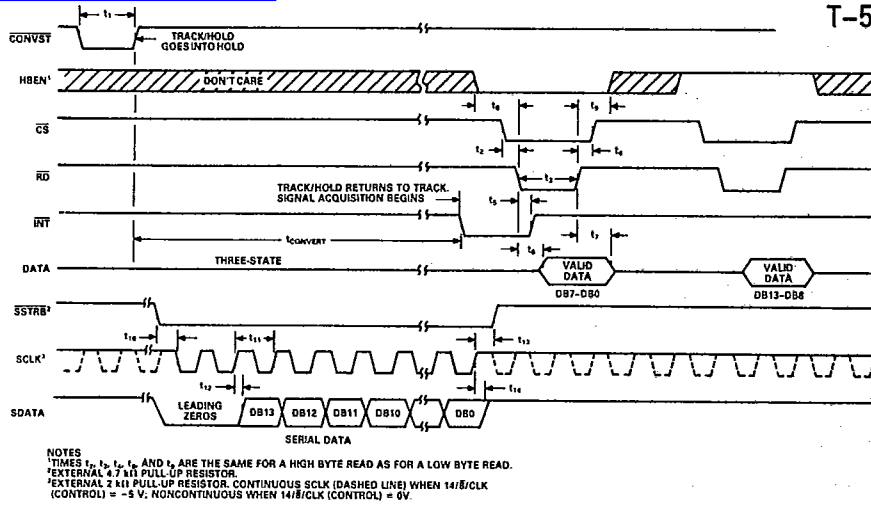

2

Figure 10. Mode 1 Timing Diagram, Byte or Serial Read

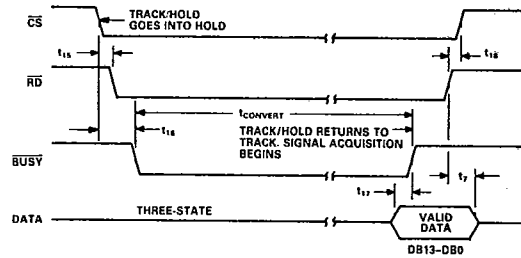

Figure 11. Mode 2 Timing Diagram, 14-Bit Parallel Read

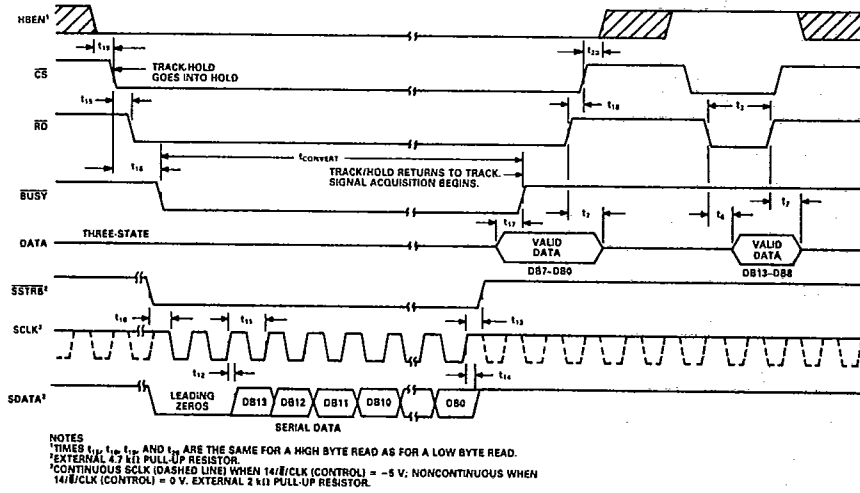

Figure 12. Mode 2 Timing Diagram, Byte or Serial Read

AD7871/AD7872

[查询 AD7871AQ"供应商"](#)

T-51-10-90

DYNAMIC SPECIFICATIONS

The AD7871/AD7872 is specified and tested for dynamic performance specifications as well as traditional dc specifications such as Integral and Differential Nonlinearity. These ac specifications are required for the signal processing applications such as Speech Recognition, Spectrum Analysis, and High Speed Modems. These applications require information on the effects on the spectral content of the input signal. Hence, the parameters for which the AD7871/AD7872 is specified include SNR, Harmonic Distortion, Intermodulation Distortion and Peak Harmonics. These terms are discussed in more detail in the following sections.

Signal-to-Noise Ratio (SNR)

SNR is the measured signal to noise ratio at the output of the ADC. The signal is the rms magnitude of the fundamental. Noise is the rms sum of all the nonfundamental signals up to half the sampling frequency ($f_s/2$) excluding dc. SNR is dependent upon the number of quantization levels used in the digitization process; the more levels, the smaller the quantization noise. The theoretical signal to noise ratio for a sine wave input is given by:

$$SNR(dB) = 16.02N + 1.76 \tag{1}$$

where N is the number of bits in the ADC. Thus for an ideal 14-bit converter, SNR = 86 dB.

The output spectrum from the ADC is evaluated by applying a sine wave signal of very low distortion to the V_{IN} input which is sampled at an 83 kHz sampling rate. A Fast Fourier Transform (FFT) plot is generated from which the SNR data can be obtained. Figure 13 shows a typical 2048 point FFT plot of the AD7871/AD7872 with an input signal of 10 kHz and a sampling frequency of 83 kHz. The SNR obtained from this graph is 80 dB. It should be noted that the harmonics are included when calculating the SNR.

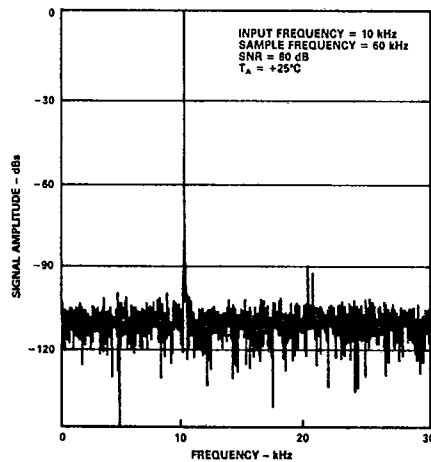

Figure 13. AD7871/AD7872 FFT Plot

Effective Number of Bits

The formula given in Equation 1 relates the SNR to the number of bits. Rewriting the formula, as in Equation 2, it is possible to get a measure of performance expressed in effective number of bits (N).

$$N = \frac{SNR - 1.76}{6.02} \tag{2}$$

The effective number of bits for a device can be calculated directly from its measured SNR. Figure 14 shows a typical plot of effective number of bits versus frequency for the AD7871/AD7872 with a sampling frequency of 60 kHz.

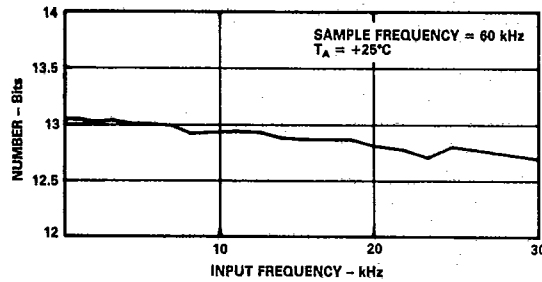

Figure 14. Effective Number of Bits vs. Frequency

Harmonic Distortion

Harmonic Distortion is the ratio of the rms sum of harmonics to the fundamental. For the AD7871/AD7872, Total Harmonic Distortion (THD) is defined as

$$THD(dB) = 20 \log \frac{\sqrt{V_2^2 + V_3^2 + V_4^2 + V_5^2 + V_6^2}}{V_1}$$

where V_1 is the rms amplitude of the fundamental and V_2, V_3, V_4, V_5 and V_6 are the rms amplitudes of the second through the sixth harmonic. The THD is also derived from the FFT plot of the ADC output spectrum. Figure 15 shows how the THD varies with input frequency.

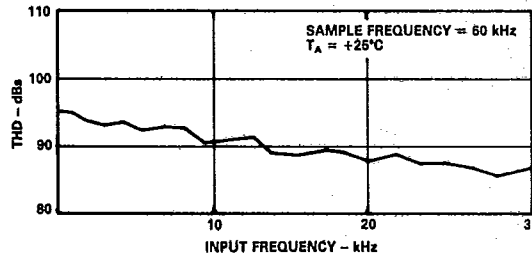

Figure 15. Total Harmonic Distortion vs. Frequency

Intermodulation Distortion

With inputs consisting of sine waves at two frequencies, f_a and f_b , any active device with nonlinearities will create distortion products at sum and difference frequencies of $m f_a \pm n f_b$ where $m, n = 0, 1, 2, 3$, etc. Intermodulation terms are those for which neither m or n are equal to zero. For example, the second order terms include $(f_a + f_b)$ and $(f_a - f_b)$, while the third order terms include $(2f_a + f_b)$, $(2f_a - f_b)$, $(f_a + 2f_b)$ and $(f_a - 2f_b)$.

[查询"AD7871AQ"供应商](#)

AD7871/AD7872

Using the CCIF standard where two input frequencies near the top end of the input bandwidth are used, the second and third order terms are of different significance. The second order terms are usually distanced in frequency from the original sine waves while the third order terms are usually at a frequency close to the input frequencies. As a result, the second and third order terms are specified separately. The calculation of the intermodulation distortion is as per the THD specification where it is the ratio of the rms sum of the individual distortion products to the rms amplitude of the fundamental expressed in dBs. In this case, the input consists of two, equal amplitude, low distortion sine waves. Figure 16 shows a typical IMD plot for the AD7871/AD7872.

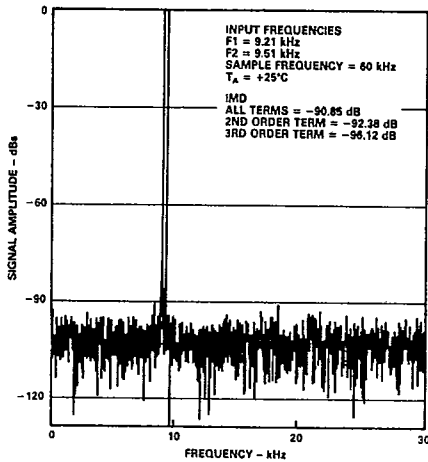

Figure 16. AD7871/AD7872 IMD Plot

Peak Harmonic or Spurious Noise

Peak Harmonic or Spurious Noise is defined as the ratio of the rms value of the next largest component in the ADC output spectrum (up to $f_s/2$ and excluding dc) to the rms value of the fundamental. Normally, the value of this specification will be determined by the largest harmonic in the spectrum, but for parts where the harmonics are buried in the noise floor peak will be a noise peak.

MICROPROCESSOR INTERFACE

The AD7871 and AD7872 have a wide variety of interfacing options. The AD7871 offers two operating modes and three data-output formats, while the AD7872 is a dedicated serial output device. The fast data access times on the parallel modes of the AD7871 allow interfacing to the very fast DSPs. The serial mode on both the AD7871 and AD7872 is compatible with the serial port structures on all the popular DSPs.

Parallel Read Interfacing

Figures 17 and 18 show interfaces to the ADSP-2100 and the TMS32020/C25 DSP processors. The AD7871 is operating in Mode 1, parallel read for both interfaces. An external timer controls conversion start asynchronously to the microprocessor. At

the end of each conversion the ADC $\overline{BUSY}/\overline{INT}$ interrupts the microprocessor and the conversion result is read from the ADC with the following instruction:

ADSP-2100 MR0 = DM(ADC)

T-51-10-90

TMS32020/C25: IN D,ADC

MR0 = ADSP-2100 MR0 Register

D = Data Memory Address

ADC = AD7871 Address

2

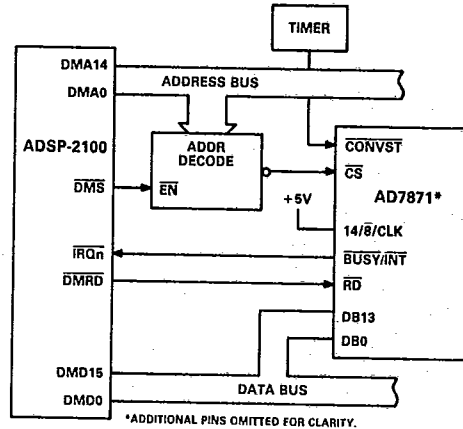

Figure 17. AD7871 to ADSP-2100 Parallel Interface

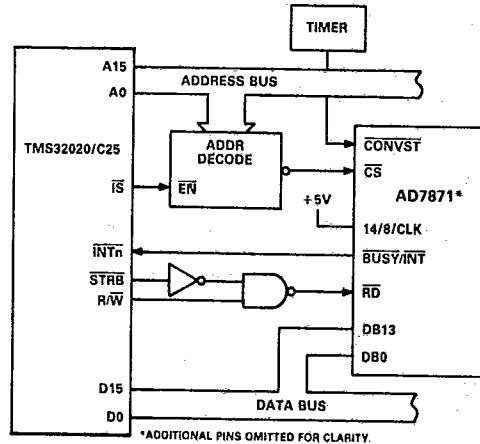

Figure 18. AD7871 to TMS32020/C25 Interface

Some applications may require that conversions be initiated by the microprocessor rather than an external timer. One option is to decode the AD7871 \overline{CONVST} from the address bus so that a write operation to the ADC starts a conversion. Data is read at the end of conversion as described earlier. Note, a read operation must not be attempted during conversion.

AD7871/AD7872

查询"AD7871AQ"供应商

Serial Interfacing

Both the AD7871 and the AD7872 have an identical serial interface. The diagrams that follow show the AD7872 interfaces only but the AD7871 could just as easily be used in these circuits. Figures 19, 20 and 21 show the AD7872 connected to three popular DSPs. In all three interfaces, CONVST is used to start conversion since this does not activate the parallel bus. Thus, the microprocessor can continue to use its parallel bus regardless of the state of the AD7872. The interfaces show a timer driving the CONVST input but this could be generated from a decoded address if required.

AD7872 - DSP56000 Serial Interface

Figure 19 shows a serial interface between the AD7872 and the DSP56000. The interface arrangement is two-wire with the AD7872 configured for noncontinuous clock operation (CONTROL = 0 V). The DSP56000 is configured for Normal Mode Asynchronous Operation with Gated Clock. It is set up for a 16-bit word with SCK as an input and the FSL control bit set to a 0. In this configuration, the DSP56000 assumes valid data on the first falling edge of SCK. Since the AD7872 provides valid data on this first edge, there is no need for a strobe or framing pulse for the data. SCLK and SDATA are three-stated when the AD7872 is not performing a conversion. During conversion data is valid on the SDATA output of the AD7872 and is clocked into the Receive Data Shift Register of the DSP56000. When this register has received 16 bits of data, it generates an internal interrupt on the DSP56000 to read the data from the register.

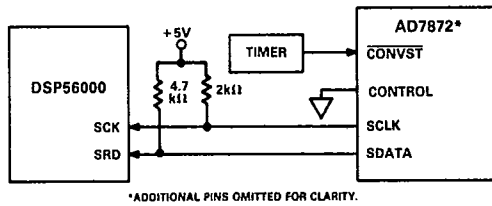

Figure 19. AD7872 to DSP56000 Interface

The DSP56000 and AD7872 can also be configured for continuous clock operation. In this case a strobe pulse is required by the DSP56000 to indicate when data is valid. The SSTRB output of the AD7872 is inverted and applied to the SC1 input of the DSP56000 to provide this strobe pulse. All other conditions and connections are the same as for the gated clock operation.

AD7872 - TMS32020/C25 Serial Interface

Figure 20 shows a serial interface between the AD7872 and the TMS32020/C25. The AD7872 is configured for continuous clock operation. Note, the ADC will not interface correctly to the TMS32020/C25 if it is configured for a noncontinuous clock. Data is clocked into the Data Receive Register (DRR) of the TMS32020/C25 during conversion. As with the previous interfaces, when a 16-bit word is received by the DSP it generates an internal interrupt to read the data from the DRR.

T-51-10-90

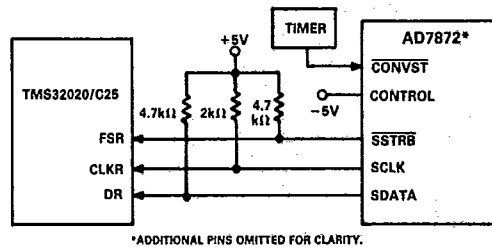

Figure 20. AD7872 to TMS32020/C25 Interface

AD7872 - ADSP-2101/ADSP-2102 Serial Interface

Figure 21 shows a serial interface between the AD7872 and the ADSP-2101/ADSP-2102 DSP Microcomputer. The AD7872 is configured for continuous clock operation. Data is clocked into the serial port register of the microcomputer during conversion. As with the previous interfaces, when a 16-bit data word is received by the ADSP-2101/ADSP-2102 an internal microprocessor interrupt is generated and the data is read from the serial port register.

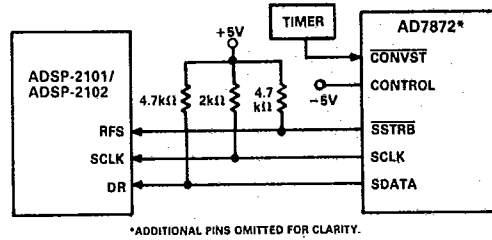

Figure 21. AD7872 to ADSP-2101/ADSP-2102 Serial Interface

STAND-ALONE OPERATION

The AD7871 can be used in its Mode 2, parallel mode for stand-alone operation. In this case, conversion is initiated with a pulse to the CS input. This pulse must be longer than the conversion time of the ADC. The BUSY output is used to drive the RD input. Data is latched from the AD7871 DB0-DB11 outputs to an external latch on the rising edge of BUSY.

APPLICATION HINTS

Good printed circuit board (PCB) layout is as important as the circuit design itself in achieving high speed A/D performance. The AD7871/AD7872 is required to make bit decisions on an LSB size of 366 μV. Thus, the designer has to be conscious of noise both in the ADC itself and in the preceding analog circuitry. Switching mode power supplies are not recommended as the switching spikes will feed through to the comparator causing noisy code transitions. Other causes of concern are ground loops and digital feedthrough from microprocessors. These are factors which influence any ADC, and a proper PCB layout which minimizes these effects is essential for best performance.

查询"AD7871AQ"供应商

T-51-10-90

AD7871/AD7872

LAYOUT HINTS

Ensure that the layout for the printed circuit board has the digital and analog signal lines separated as much as possible. Take care not to run a digital track alongside an analog signal track. Guard (screen) the analog input with AGND.

Establish a single point analog ground (star ground) separate from the logic system ground at the AD7871/AD7872 AGND pin or as close as possible to the AD7871/AD7872. Connect all other grounds and the AD7871/AD7872 DGND to this single analog ground point. Do not connect any other digital grounds to this analog ground point.

Low impedance analog and digital power supply common returns are essential to low noise operation of the ADC, so make the foil width for these tracks as wide as possible. The use of ground planes minimizes impedance paths and also guards the analog circuitry from digital noise. The circuit layout of Figures 26 and 27 have both analog and digital ground planes which are kept separated and only joined together at the AD7871/AD7872 AGND pin.

NOISE

Keep the input signal leads to V_{IN} and signal return leads from AGND as short as possible to minimize input noise coupling. In applications where this is not possible, use a shielded cable between the source and the ADC. Reduce the ground circuit impedance as much as possible since any potential difference in grounds between the signal source and the ADC appears as an error voltage in series with the input signal.

DATA ACQUISITION BOARD

Figure 24 shows the AD7871/AD7872 in a data acquisition circuit. The corresponding printed circuit board (PCB) layout has three interface ports: one serial and two parallel. Note that the AD7871/AD7872 serial lines are buffered by a 74HC244. This allows long lines with large capacitive loads to be driven. One of the parallel ports is directly compatible with the ADSP-2100 evaluation board expansion connector.

The only additional component required for a full data acquisition system is an anti-aliasing filter. There is a component grid provided near the analog input on the PCB which may be used for such a filter or any other input conditioning circuitry. To facilitate this option, there is a shorting plug (labelled LK1 on the PCB) on the analog input track. If this shorting plug is used, the analog input connects to the buffer amplifier driving the AD7871/AD7872; if this shorting plug is omitted, a wire link can be used to connect the analog input to the PCB component grid.

INTERFACE CONNECTIONS

There are two parallel connectors labeled SKT4 and SKT6 and one serial connector labeled SKT5. A shorting plug option (LK3 in Figure 24) configures the ADC for the appropriate interface.

SKT6 is a 96-contact (3-row) Eurocard connector which is directly compatible with the ADSP-2100 Evaluation Board Prototype Expansion Connector. The expansion connector on the ADSP-2100 has eight decoded chip enable outputs labeled ECE1 to ECE8. ECE6 is used to drive the AD7871 \overline{CS} input on the board. To avoid selecting the on-board RAM sockets at the same time, LK6 on the ADSP-2100 board must be removed. In addition, the ADSP-2100 expansion connector has four inter-

rupts labelled EIRQ0 to EIRQ3. The AD7871 $\overline{BUSY}/\overline{INT}$ output connects to EIRQ0. There is a single wait state generator connected to EDMACK to allow the AD7871 to interface to the faster versions of the ADSP-2100.

SKT4 is a 26-way (2-row) IDC connector. This contains the same signal contacts as SKT6 except for EDMACK which is connected to SKT6 only. It also contains decoded $\overline{R}/\overline{W}$ and \overline{STRB} inputs which are necessary for TMS32020 interfacing.

SKT5 is a 5-way D-type connector which is meant for serial interfacing only. An inverted DB11/SCLK output is also provided on this connector for systems which accept data on a rising clock edge.

SKT1, SKT2 and SKT3 are three BNC connectors which provide connections for the analog input, the CONVST input and an external clock.

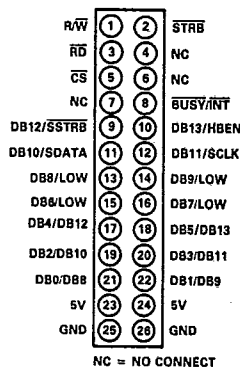

Figure 22. SKT4 Pinout

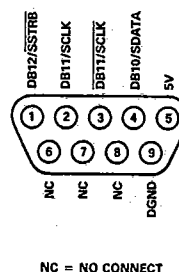

Figure 23. SKT5 Pinout

POWER SUPPLY CONNECTIONS

The PCB requires two analog power supplies and one 5 V logic supply. The analog supplies are labelled $V+$ and $V-$, and the range for both supplies is 12 V to 15 V. Connection to the 5 V digital supply is made through any of the connectors SKT4 to SKT6. The ± 5 V supply required by the AD7871 and AD7872 is generated from voltage regulators on the $V+$ and $V-$ power supplies input (IC6 and IC7 in Figure 24).

SHORTING PLUG OPTIONS

There are seven shorting plug options which must be set before using the board. These are outlined below:

- LK1 Connects the analog input to a buffer amplifier. The analog input may also be connected to a component grid for signal conditioning.
- LK2 Selects either the AD7871/AD7872 internal clock or an external clock source.
- LK3 Configures the AD7871 $14/\overline{8}/\overline{CLK}$ input for the appropriate serial or parallel interface.
- LK4 Connects the AD7871 \overline{RD} input directly to the two parallel connectors or to a decoded \overline{STRB} and $\overline{R}/\overline{W}$ input.
- LK5 Connects the pull-up resistor R3 to \overline{SSTRB} .
- LK6 Connects the pull-up resistor R4 to SCLK.
- LK7 Connects the pull-up resistor R5 to SDATA.

Note that LK5 to LK7 should be removed for parallel interfacing.

AD7871/AD7872

查询"AD7871AQ"供应商

T-51-10-90

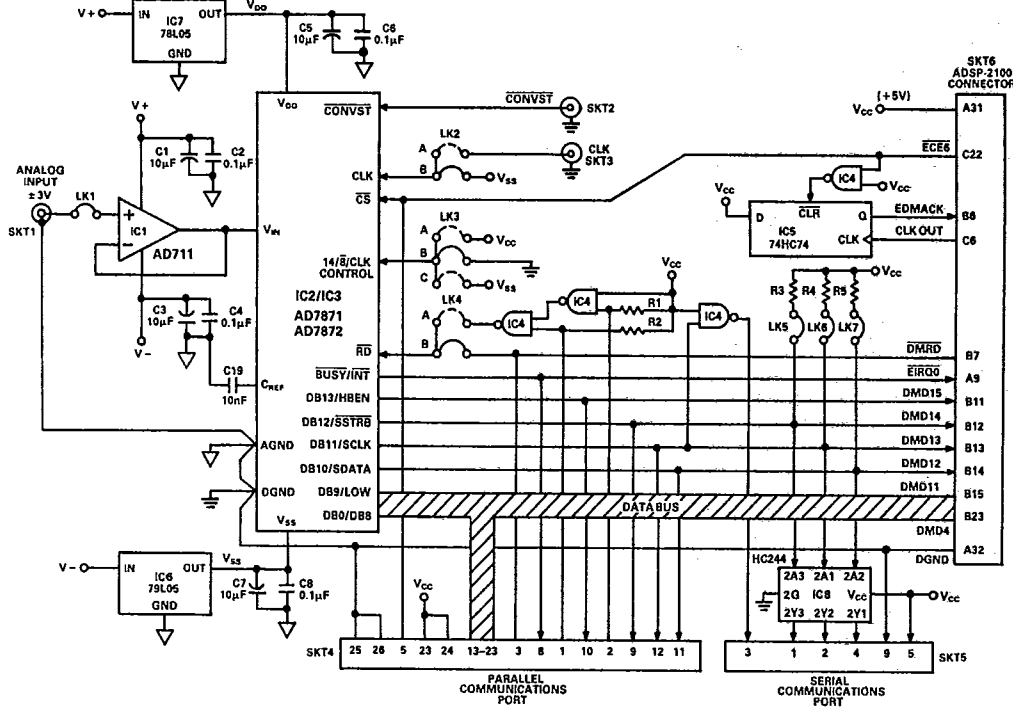

Figure 24. Data Acquisition Circuit Using the AD7871/AD7872

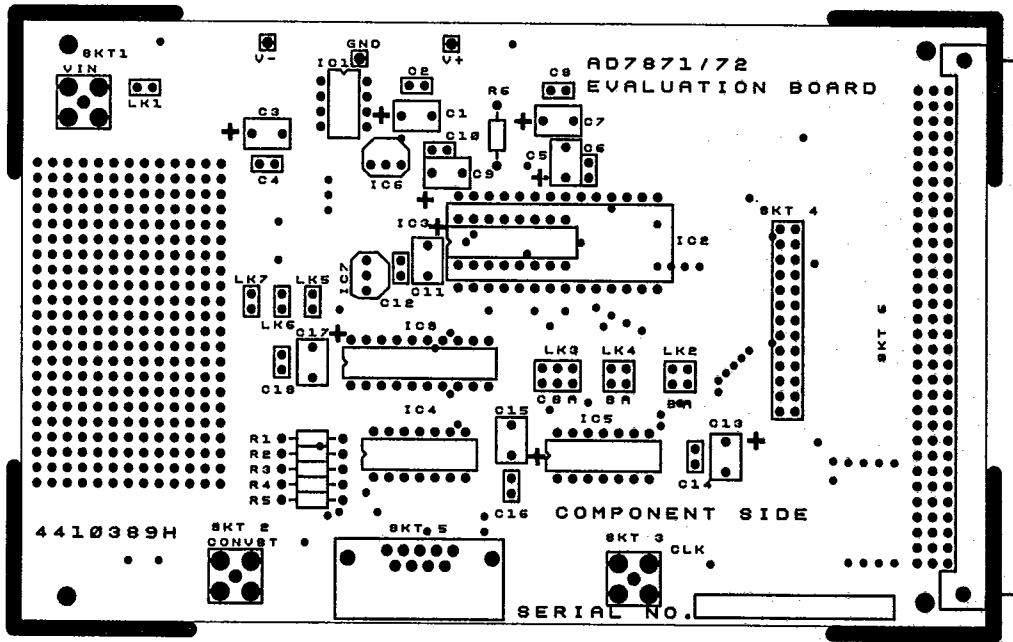

Figure 25. PCB Silkscreen for Figure 24

[查询"AD7871AQ"供应商](#)

AD7871/AD7872

T-51-10-90

2

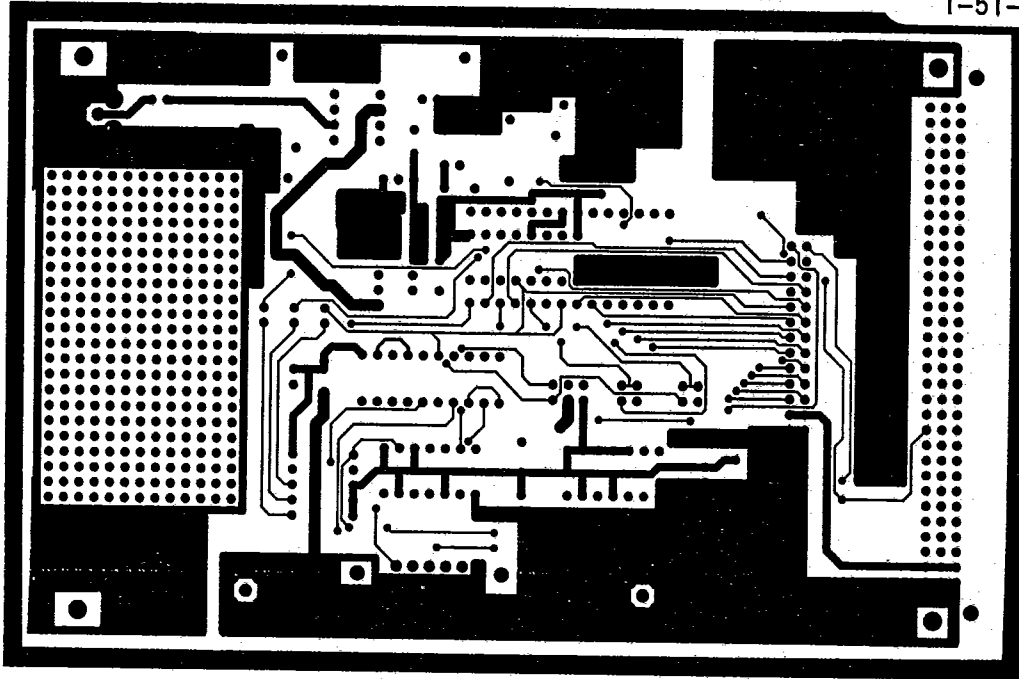

Figure 26. PCB Component Side Layout for Figure 24

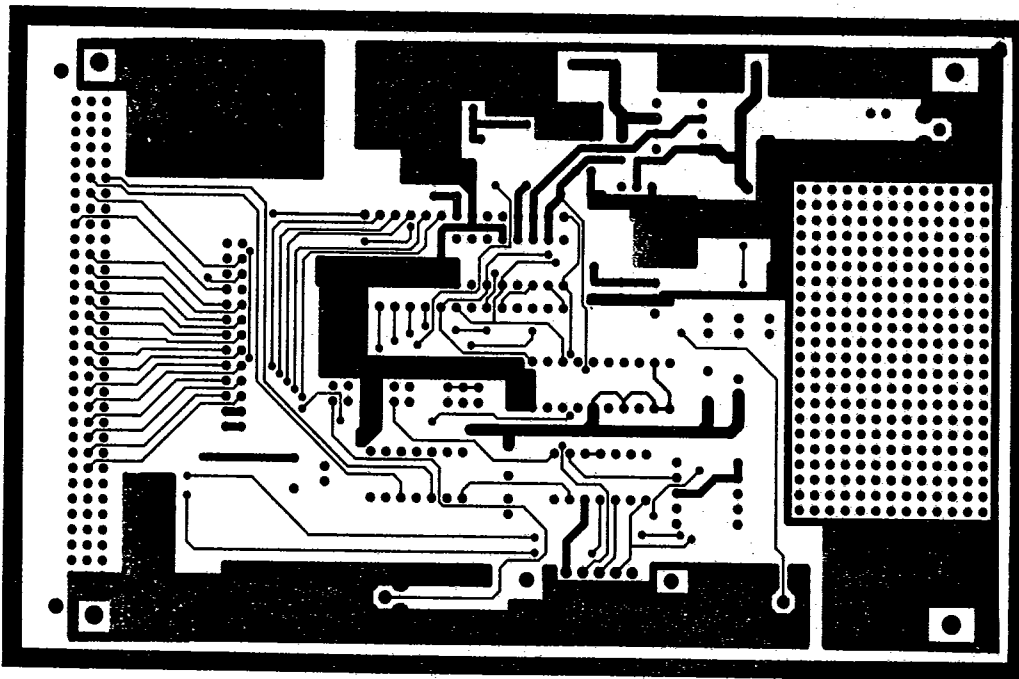

Figure 27. PCB Solder Side Layout for Figure 24

AD7871/AD7872
[查询 AD7871AQ"供应商"](#)

T-51-10-90

AD7871 ORDERING GUIDE

Model ^{1, 2}	Temperature Range	SNR	Relative Accuracy	Package Option ³
AD7871JN	0°C to +70°C	80 dBs min		N-28
AD7871KN	0°C to +70°C	80 dBs min	±1 max	N-28
AD7871JP	0°C to +70°C	80 dBs min		P-28A
AD7871KP	0°C to +70°C	80 dBs min	±1 max	P-28A
AD7871AQ	-40°C to +85°C	80 dBs min		Q-28
AD7871BQ	-40°C to +85°C	80 dBs min	±1 max	Q-28
AD7871TQ ⁴	-55°C to +125°C	79 dBs min	±1 max	Q-28

NOTES

¹To order MIL-STD-883, Class B, processed parts, add /883B to part number. Contact local sales office for military data sheet.

²Contact local sales office for LCCC availability.

³N = Plastic DIP; P = Plastic Leaded Chip Carrier (PLCC); Q = Cerdip.

For outline information see Package Information section.

⁴Available to /883B processing only.

AD7872 ORDERING GUIDE

Model ¹	Temperature Range	SNR	Relative Accuracy	Package Option ²
AD7872JN	0°C to +70°C	80 dBs min		N-16
AD7872KN	0°C to +70°C	80 dBs min	±1 max	N-16
AD7872JR	0°C to +70°C	80 dBs min		R-16
AD7872KR	0°C to +70°C	80 dBs min	±1 max	R-16
AD7872AQ	-40°C to +85°C	80 dBs min		Q-16
AD7872BQ	-40°C to +85°C	80 dBs min	±1 max	Q-16
AD7872TQ ³	-55°C to +125°C	79 dBs min	±1 max	Q-16

NOTES

¹To order MIL-STD-883, Class B, processed parts, add /883B to part number. Contact local sales office for military data sheet.

²N = Plastic DIP; Q = Cerdip; R = Small Outline IC (SOIC). For outline information see Package Information section.

³Available to /883B processing only.