

# 3.3V Parallel printer interface transceiver/buffer

# 74LVC1284

[查询"74LVC1284D"供应商](#)

## FEATURES

- Asynchronous operation
- 4-Bit transceivers
- 3 additional buffer/driver lines
- TTL compatible inputs
- ESD protection exceeds 1000V per MIL STD 883 Method 3015 and 200V per Machine Model
- Input Hysteresis
- Low Noise Operation
- Center Pin  $V_{CC}$  & GND
- IEEE 1284 Compliant Level 1 & 2
- Overvoltage Protection on B side

## DESCRIPTION

The 74LVC1284 parallel interface chip is designed to provide an asynchronous, 4-bit, bi-directional, parallel printer interface for personal computers. Three additional lines are included to provide handshaking signals between the host and the peripheral. The part is designed to match IEEE 1284 standard.

The 4 transceiver pins (A/B 1-4) allow data transmission from the A bus to the B bus, or from the B bus to the A bus, depending on the state of the direction pin DIR.

The B bus and the Y5-Y7 lines have totem pole or open drain style outputs depending on the state of the high drive enable pin HD. The A bus only has totem pole style outputs. All inputs are TTL compatible with at least 300mV of input hysteresis at  $V_{CC} = 3.3V$ .

## QUICK REFERENCE DATA

SYMBOL	PARAMETER	CONDITIONS $T_{amb} = 25^{\circ}C$ ; GND = 0V	TYPICAL	UNIT
$R_D$	B/Y Side output resistance	$V_{CC} = 3.3V$ ; $V_O = 1.65V \pm 0.2V$ (See Figure 2)	45	$\Omega$
SR	B/Y Side slew rate	$R_L = 62\Omega$ ; $C_L = 50pF$ (See Waveform 4)	0.2	V/ns
$I_{CC}$	Total static current	$V_I = V_{CC}/GND$ ; $I_O = 0$	5	$\mu A$
$V_{HYS}$	Input hysteresis	$V_{CC} = 3.3V$	0.4	V
$t_{PLH}/t_{PHL}$ A-B/Y	Propagation delay to the B/Y side outputs	$V_{CC} = 3.3V$	12.6/14.0	ns

## ORDERING INFORMATION

PACKAGES	TEMPERATURE RANGE	ORDER CODE	DRAWING NUMBER
20-pin plastic SO	0°C to +70°C	7LVC1284D	SOT163-1
20-pin plastic SSOP Type II	0°C to +70°C	74LVC1284DB	SOT339-1
20-pin plastic TSSOP Type I	0°C to +70°C	74LVC1284PW	SOT360-1

## PIN CONFIGURATION

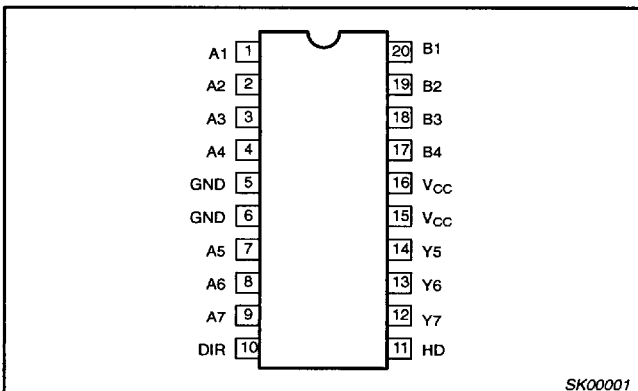

## LOGIC SYMBOL

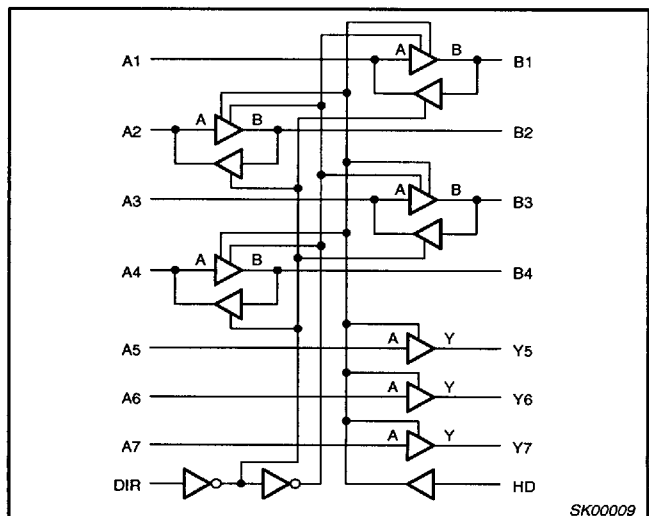

## 3.3V Parallel printer interface transceiver/buffer

74LVC1284

[查询"74LVC1284D"供应商](#)

## PIN DESCRIPTION

PIN NUMBER	SYMBOL	FUNCTION
1,2,3,4	A1 - A4	Data inputs/outputs
20,19,18,17	B1 - B4	IEEE 1284 Std. outputs/inputs
7,8,9	A5 - A7	Data inputs
14,13,12	Y5 - Y7	IEEE 1284 Std. outputs
10	DIR	Direction selection
11	HD	B/Y-side high drive enable/disable
5,6	GND	Ground (0V)
15,16	V <sub>CC</sub>	Positive supply voltage

## FUNCTION TABLE

INPUTS			OUTPUTS	INPUTS/OUTPUTS	
DIR	HD	A5-7	Y5-7	A1-4	B1-4
L	L	L	L	A = B	Inputs
L	L	H	Z	A = B	Inputs
L	H	L	L	A = B	Inputs
L	H	H	H	A = B	Inputs
H	L	L	L	Inputs Low	Outputs Low
H	L	H	Z	Inputs High	Outputs Z
H	H	L	L	Inputs	B = A
H	H	H	H	Inputs	B = A

H = High Voltage  
L = Low Voltage  
Z = High Impedance, Off-State

ABSOLUTE MAXIMUM RATINGS<sup>1, 2</sup>

SYMBOL	PARAMETER	CONDITIONS	RATING	UNIT
	ESD Immunity, per Mil Std 883C method 3015		±2	kV
V <sub>CC</sub>	DC supply voltage		-0.5 to +4.6	V
I <sub>IK</sub>	DC input diode current	V <sub>I</sub> < 0	±20	mA
I <sub>OK</sub>	DC output diode current	V <sub>O</sub> < 0	±50	mA
V <sub>IN</sub>	DC input voltage <sup>3</sup>		-0.5 to +5.5	V
V <sub>OUT B/YDC</sub>	DC output voltage on B/Y side <sup>3</sup>		-0.5 to +5.5	V
V <sub>OUT B/Y (tr)</sub>	Transient output voltage on B/Y side <sup>4</sup>	40ns transient	-2 to +7	V
V <sub>OUT A side</sub>	DC output voltage on A side		-0.5 to V <sub>CC</sub> +0.5	V
I <sub>O</sub>	DC output current	Outputs in High or Low state	±50	mA
T <sub>stg</sub>	Storage temperature range		-60 to +150	°C
I <sub>CC</sub> /I <sub>GND</sub>	Continuous current through V <sub>CC</sub> or GND		±200	mA

## NOTES:

- Stresses beyond those listed may cause permanent damage to the device. These are stress ratings only and functional operation of the device at these or any other conditions beyond those indicated under "recommended operating conditions" is not implied. Exposure to absolute-maximum-rated conditions for extended periods may affect device reliability.
- The performance capability of a high-performance integrated circuit in conjunction with its thermal environment can create junction temperatures which are detrimental to reliability. The maximum junction temperature of this integrated circuit should not exceed 150°C.
- The input and output voltage ratings may be exceeded if the input and output current ratings are observed.
- V<sub>OUT B/Y (tr)</sub> guarantees only that this part will not be damaged by reflections in application so long as the voltage levels remain in the specified range.

## RECOMMENDED OPERATING CONDITIONS

SYMBOL	PARAMETER	LIMITS		UNIT
		MIN	MAX	
V <sub>CC</sub>	DC supply voltage	3.0	3.6	V
V <sub>I</sub>	Input voltage	0	V <sub>CC</sub>	V
V <sub>OUT</sub>	B/Y output voltage	-0.5	5.5	V
V <sub>OUT</sub>	A side output voltage	0	V <sub>CC</sub>	V
I <sub>OH</sub>	B/Y side output current High		-14	mA
I <sub>OL</sub>	B/Y side output current Low		14	mA
T <sub>amb</sub>	Operating free-air temperature range	0	+70	°C

## 3.3V Parallel printer interface transceiver/buffer

74LVC1284

[查询"74LVC1284D"供应商](#)

## DC ELECTRICAL CHARACTERISTICS

SYMBOL	PARAMETER	TEST CONDITIONS	LIMITS					UNIT		
			T <sub>amb</sub> = 25°C			T <sub>amb</sub> = 0°C to +70°C				
			MIN	TYP	MAX	MIN	MAX			
V <sub>OH</sub>	High-level output voltage	An	V <sub>CC</sub> = Min to Max; I <sub>OH</sub> = -50μA		V <sub>CC</sub> -0.2	V <sub>CC</sub>		V <sub>CC</sub> -0.2	V	
			V <sub>CC</sub> = 3.0V; I <sub>OH</sub> = -4mA		2.4			2.4	V	
	Bn or Yn	V <sub>CC</sub> = 3.0V; I <sub>OH</sub> = 14mA		2.2	2.4		2.1	V		
V <sub>OL</sub>	Low-level output voltage	An	V <sub>CC</sub> = Min to Max; I <sub>OL</sub> = 50μA; V <sub>I</sub> = V <sub>IL</sub> or V <sub>IH</sub>				0.2		0.2	V
				V <sub>CC</sub> = 3.0V; I <sub>OL</sub> = 4mA; V <sub>I</sub> = V <sub>IL</sub> or V <sub>IH</sub>					0.4	0.4
		Bn or Yn	V <sub>CC</sub> = 3.0V; I <sub>OL</sub> = -14mA; V <sub>I</sub> = V <sub>IL</sub> or V <sub>IH</sub>					0.8	0.9	V
V <sub>IH</sub>	High-level input voltage	V <sub>CC</sub> = Min to Max				2.0		2.0		
V <sub>IL</sub>	Low-level input voltage	V <sub>CC</sub> = Min to Max		0.8			0.8			
V <sub>HYS</sub>	Input Hysteresis	V <sub>CC</sub> = 3.3V			0.4		0.3		V	
R <sub>D</sub>	B/Y side Output Impedance	See Figure 2		38	45	53	35	55	Ω	
I <sub>I</sub>	Input leakage current (A5-A7 DIR, HD)	V <sub>CC</sub> = 3.6V; V <sub>O</sub> = V <sub>CC</sub> or GND				±1.0		±5.0	μA	
I <sub>OFF</sub>	B/Y Side Power-off leakage current	V <sub>CC</sub> = 0.0V; V <sub>O</sub> = 0 to 5.5V				±10		±100	μA	
I <sub>OZH</sub>	3-State output High current Yn	V <sub>CC</sub> = 3.6V; V <sub>O</sub> = V <sub>CC</sub> ; V <sub>I</sub> = V <sub>IL</sub> or V <sub>IH</sub>				5		20	μA	
I <sub>OZL</sub>	3-State output Low current Yn	V <sub>CC</sub> = 3.6V; V <sub>O</sub> = GND; V <sub>I</sub> = V <sub>IL</sub> or V <sub>IH</sub>				-5		-20	μA	
I <sub>IH</sub> +I <sub>OZH</sub>	current (A1 - A4, Bn)	V <sub>CC</sub> = 3.6V; V <sub>I/O</sub> = V <sub>CC</sub>				5		25	μA	
I <sub>IL</sub> +I <sub>OZL</sub>	current (A1 - A4, Bn)	V <sub>CC</sub> = 3.6V; V <sub>I/O</sub> = GND				-5		-25	μA	
I <sub>CC</sub>	Quiescent Supply Current	V <sub>CC</sub> = 3.6V; I <sub>O</sub> = 0; V <sub>I</sub> = GND or V <sub>CC</sub>			5	10		50	μA	

## AC CHARACTERISTICS

GND = 0V, t<sub>R</sub> = t<sub>F</sub> = 3.0ns, C<sub>L</sub> = 50pF, R<sub>L</sub> = 500Ω

SYMBOL	PARAMETER	WAVEFORM	LIMITS					UNIT
			T <sub>amb</sub> = 25°C V <sub>CC</sub> = 3.3V			T <sub>amb</sub> = 0 to +70°C V <sub>CC</sub> = Min to Max		
			MIN	TYP	MAX	MIN	MAX	
SR	B-Side Slew Rate	4	0.05	0.2	0.35	0.05	0.4	V/ns
t <sub>PLH</sub> t <sub>PHL</sub>	Propagation delay A to Y or A to B	5	6.0 6.0	12.6 12.4	18.0 18.0	5.0 5.0	19.5 20.0	ns
t <sub>PLH</sub> t <sub>PHL</sub>	Propagation delay B to A	1	1.5 1.5	5.5 5.6	7.9 7.6	1.5 1.5	9.5 9.0	ns
t <sub>PZH</sub> t <sub>PHZ</sub>	Output enable/disable time to/from High level HD to Y or HD to B	2	4.0 2.0	12.0 6.5	16.0 9.1	4.0 2.0	20.0 11.0	ns
t <sub>PZL</sub> t <sub>PLZ</sub>	Output enable/disable time to/from Low level A to Y or A to B	2	5.0 1.5	12.7 5.0	16.3 7.1	5.0 1.5	20.0 9.0	ns
t <sub>PZH</sub> t <sub>PZL</sub>	Output enable time from DIR to B	2	8.0 8.0	12.3 12.7	18.0 18.0	4.0 4.0	20.0 20.0	ns
t <sub>PHZ</sub> t <sub>PLZ</sub>	Output disable time from DIR to B	2	5.0 6.0	8.9 9.1	12.5 12.0	2.0 2.0	14.5 14.0	ns
t <sub>PZH</sub> t <sub>PZL</sub>	Output enable time from DIR to A	2	3.5 4.0	6.9 8.6	13.0 14.0	3.0 3.0	14.5 16.0	ns
t <sub>PHZ</sub> t <sub>PLZ</sub>	Output disable from DIR to A	2	2.5 2.5	3.7 3.7	5.5 5.0	2.0 2.0	6.0 5.5	ns

# 3.3V Parallel printer interface transceiver/buffer

74LVC1284

[查询"74LVC1284D"供应商](#)

## AC WAVEFORMS

$V_M = 1.5V$

$V_X = V_{OL} \pm 0.3V$

$V_Y = V_{OH} - 0.3V$

$V_{OL}$  and  $V_{OH}$  are the typical output voltage drops that occur with the output load. ( $V_{CC}$  never goes below 3.0V).

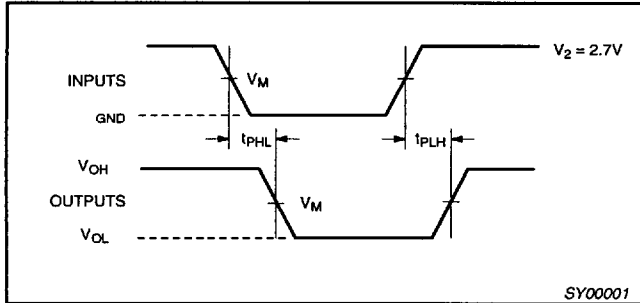

Waveform 1. Input Bn to output An propagation delays

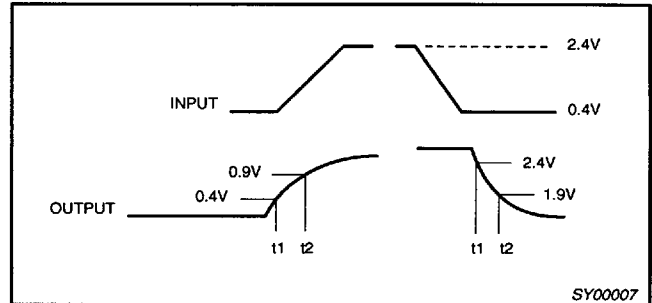

Waveform 4. Slew Rate Waveforms Voltage Waveforms (Input pulse rise and fall time are 3ns, 150ns < pulse width < 10 μs, for both a Low to High and a High to Low transition.) Slew Rate measured between 0.4V and 0.9V - rising. Slew Rate measured between 2.4V and 1.9V - falling. Slew Rate measured at TP1.

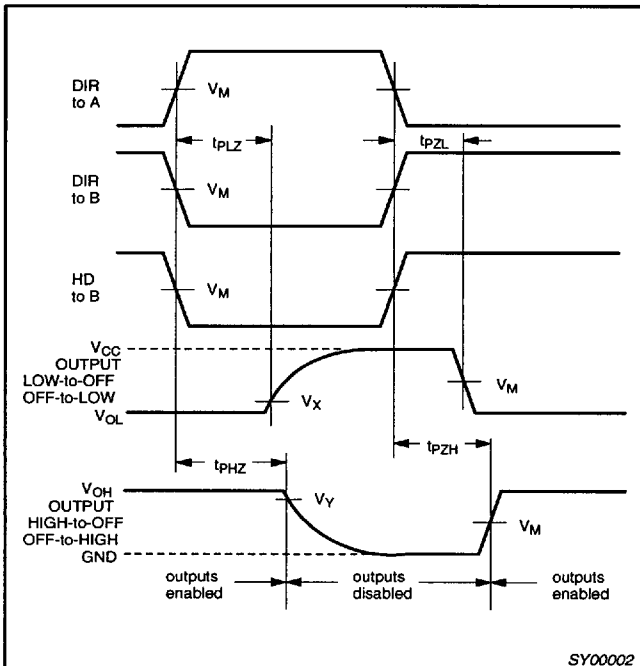

Waveform 2. 3-State enable and disable times

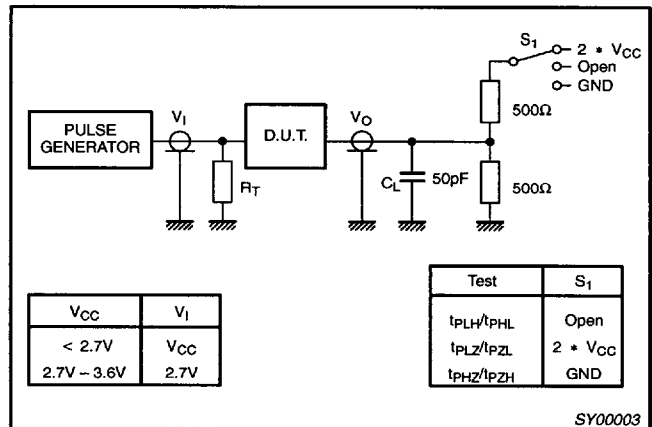
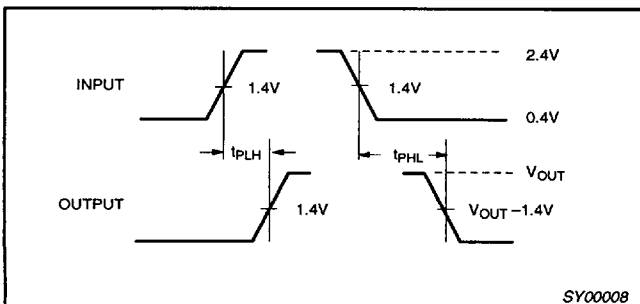

Figure 1. Load Circuitry for Bn to An Switching Times



Waveform 3. Voltage Waveforms Propagation Delay Times (A To B) Measured at Output Pin

## TEST CIRCUIT

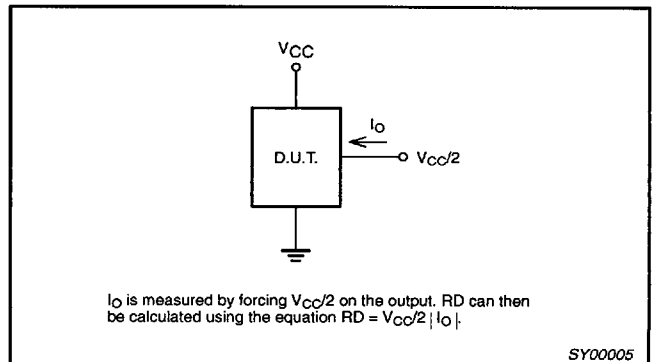
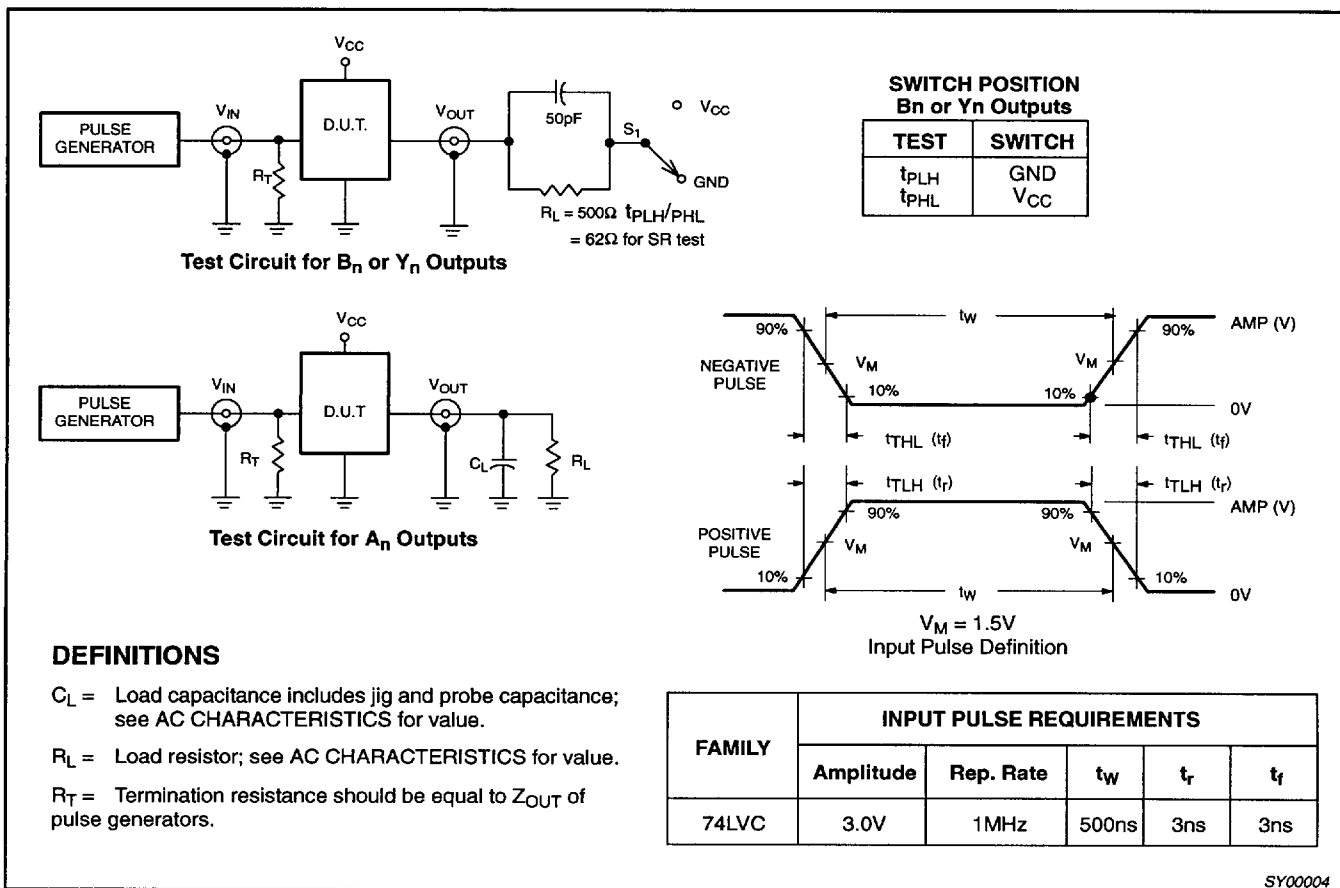

Figure 2. Output Impedance  $R_D$

3.3V Parallel printer interface transceiver/buffer

74LVC1284

查询"74LVC1284D"供应商



Waveform 5.

SY00004

3.3V Parallel printer interface transceiver/buffer

74LVC1284

[查询"74LVC1284D"供应商](#)

SO20: plastic small outline package; 20 leads; body width 7.5 mm

SOT163-1

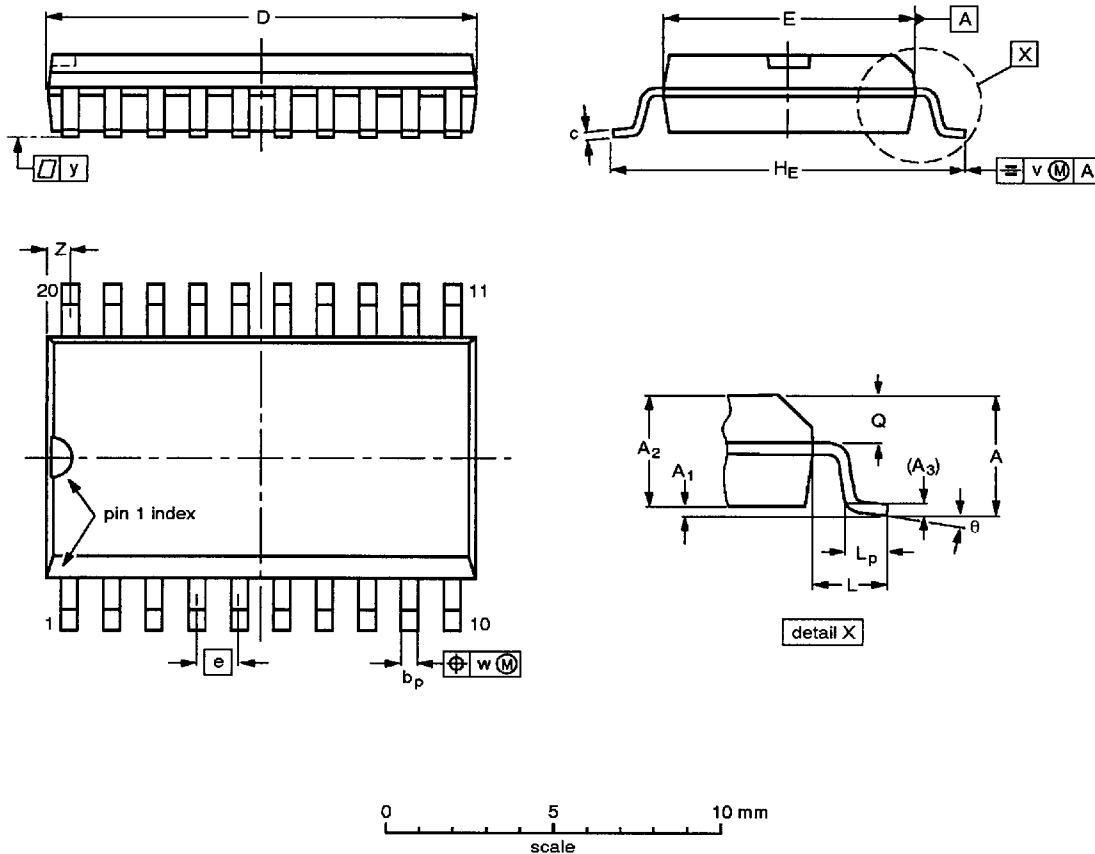

**DIMENSIONS (inch dimensions are derived from the original mm dimensions)**

UNIT	A max.	A <sub>1</sub>	A <sub>2</sub>	A <sub>3</sub>	b <sub>p</sub>	c	D <sup>(1)</sup>	E <sup>(1)</sup>	e	H <sub>E</sub>	L	L <sub>p</sub>	Q	v	w	y	Z <sup>(1)</sup>	θ
mm	2.65	0.30 0.10	2.45 2.25	0.25	0.49 0.36	0.32 0.23	13.0 12.6	7.6 7.4	1.27	10.65 10.00	1.4	1.1 0.4	1.1 1.0	0.25	0.25	0.1	0.9 0.4	8° 0°
inches	0.10	0.012 0.004	0.096 0.089	0.01	0.019 0.014	0.013 0.009	0.51 0.49	0.30 0.29	0.050	0.42 0.39	0.055	0.043 0.016	0.043 0.039	0.01	0.01	0.004	0.035 0.016	

**Note**

1. Plastic or metal protrusions of 0.15 mm maximum per side are not included.

OUTLINE VERSION	REFERENCES				EUROPEAN PROJECTION	ISSUE DATE
	IEC	JEDEC	EIAJ			
SOT163-1	075E04	MS-013AC				92-11-17 95-01-24

3.3V Parallel printer interface transceiver/buffer

74LVC1284

[查询"74LVC1284D"供应商](#)

SSOP20: plastic shrink small outline package; 20 leads; body width 5.3 mm

SOT339-1

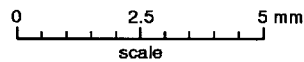
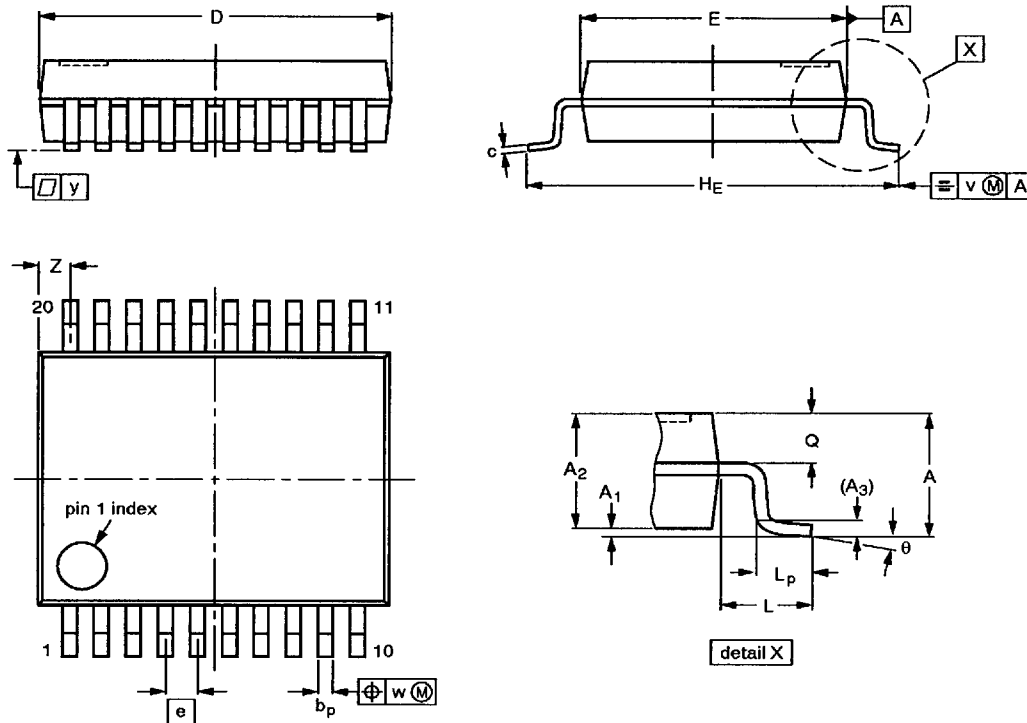

DIMENSIONS (mm are the original dimensions)

UNIT	A max.	A <sub>1</sub>	A <sub>2</sub>	A <sub>3</sub>	b <sub>p</sub>	c	D <sup>(1)</sup>	E <sup>(1)</sup>	e	H <sub>E</sub>	L	L <sub>p</sub>	Q	v	w	y	z <sup>(1)</sup>	θ
mm	2.0	0.21 0.05	1.80 1.65	0.25	0.38 0.25	0.20 0.09	7.4 7.0	5.4 5.2	0.65	7.9 7.6	1.25	1.03 0.63	0.9 0.7	0.2	0.13	0.1	0.9 0.5	8° 0°

Note

1. Plastic or metal protrusions of 0.20 mm maximum per side are not included.

OUTLINE VERSION	REFERENCES			EUROPEAN PROJECTION	ISSUE DATE
	IEC	JEDEC	EIAJ		
SOT339-1		MO-150AE			93-09-08 95-02-04

3.3V Parallel printer interface transceiver/buffer

74LVC1284

[查询"74LVC1284D"供应商](#)

TSSOP20: plastic thin shrink small outline package; 20 leads; body width 4.4 mm

SOT360-1

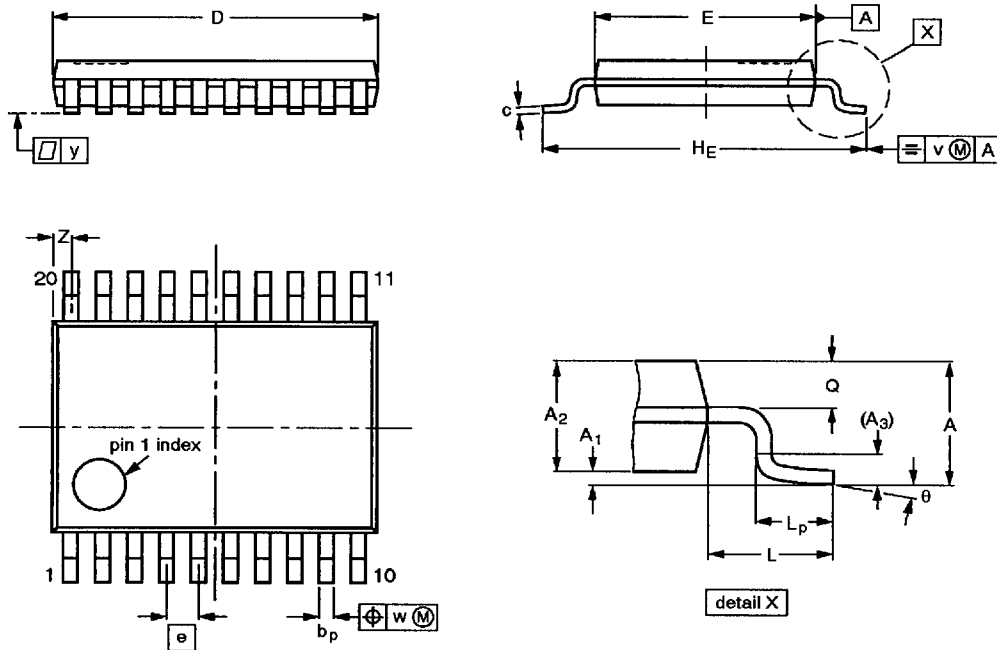

DIMENSIONS (mm are the original dimensions)

UNIT	A max.	A <sub>1</sub>	A <sub>2</sub>	A <sub>3</sub>	b <sub>p</sub>	c	D <sup>(1)</sup>	E <sup>(2)</sup>	e	H <sub>E</sub>	L	L <sub>p</sub>	Q	v	w	y	z <sup>(1)</sup>	$\theta$
mm	1.10	0.15 0.05	0.95 0.80	0.25	0.30 0.19	0.2 0.1	6.6 6.4	4.5 4.3	0.65	6.6 6.2	1.0	0.75 0.50	0.4 0.3	0.2	0.13	0.1	0.5 0.2	8° 0°

Notes

1. Plastic or metal protrusions of 0.15 mm maximum per side are not included.
2. Plastic interlead protrusions of 0.25 mm maximum per side are not included.

OUTLINE VERSION	REFERENCES				EUROPEAN PROJECTION	ISSUE DATE
	IEC	JEDEC	EIAJ			
SOT360-1		MO-153AC				-93-06-16 95-02-04