

BHL CONNECTOR



Disconnectable Crimp style connectors

查询"SM02B-BHLS-1-TB"供应商



Low profile connector with high withstanding voltage, designed for connecting liquid crystal display backlight lamps to their starters. The BHL connector is 2.8mm (.110") thick, so the mounting height is only 3mm (.118").

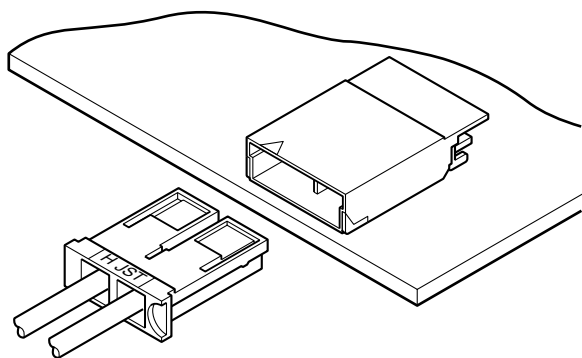

Features

• Contact lances

Contacts are secured in the housing by their spring action, thus fully shrouded. This helps improve the withstanding voltage.

• Anti-misinsertion housing

The housing has mis-insertion preventive guides on both sides. Housing locks prevent release of the housing that might result from vibration or shock.

Specifications

- Current rating: 1.0A AC, DC
- Voltage rating: 1,400V AC, DC
- Temperature range: -25°C to +85°C
(including temperature rise in applying electrical current)
- Contact resistance: Initial value/10m Ω max.
After environmental testing/20m Ω max.
- Insulation resistance: 1,000M Ω min.
- Withstanding voltage: 3,800V AC/minute
- Applicable wire: Conductor/AWG #28 to #24
Insulation O. D./0.9 to 1.7mm(.035" to .067")

* Contact JST for details.

BHL CONNECTOR

Contact

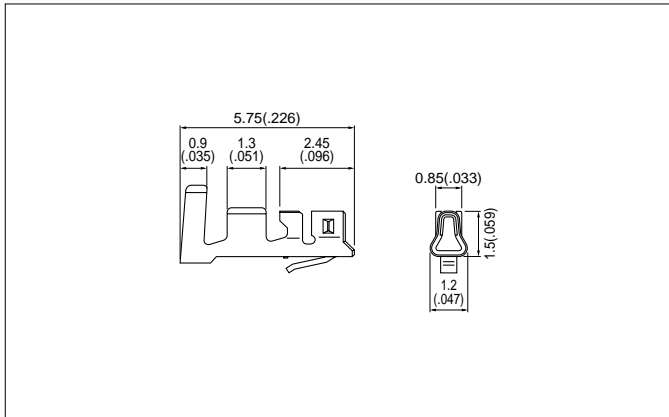

Model No.	Applicable wire			Q'ty / reel
	mm ²	AWG #	Insulation O.D. mm(in.)	
SBHL-002T-P0.5	0.08 to 0.22	28 to 24	0.9 to 1.7(.035 to .067)	10,000
Material and Finish				
Phosphor bronze, tin-plated				

Housing

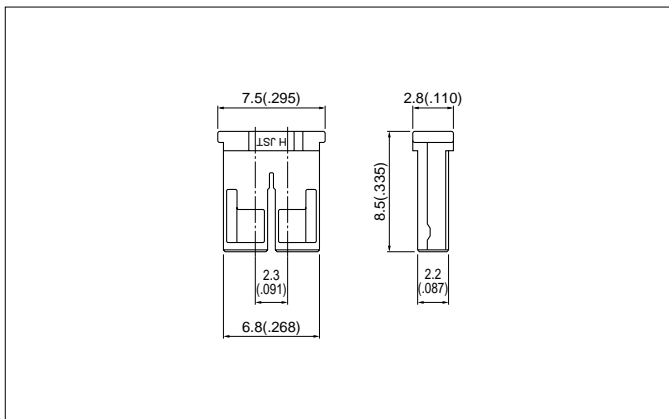

Circuits	Model No.	Q'ty / bag
2	BHLR-02VS	1,000
Material		
Thermosetting resin, UL94V-0, black		

Shrouded header

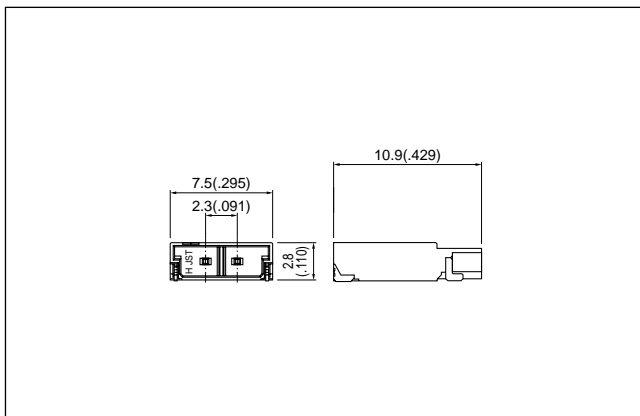

Circuits	Model No.	Q'ty / reel
2	SM02B-BHLS-1-TB	1,500
Material and Finish		
Post: Brass, copper-undercoated, tin/lead-plated		
Wafer: Heat resistant resin, UL94V-0, natural (ivory)		
Solder tab: Brass, copper-undercoated, tin/lead-plated		

Note: The products listed above are supplied on embossed-tape.

Taping specifications

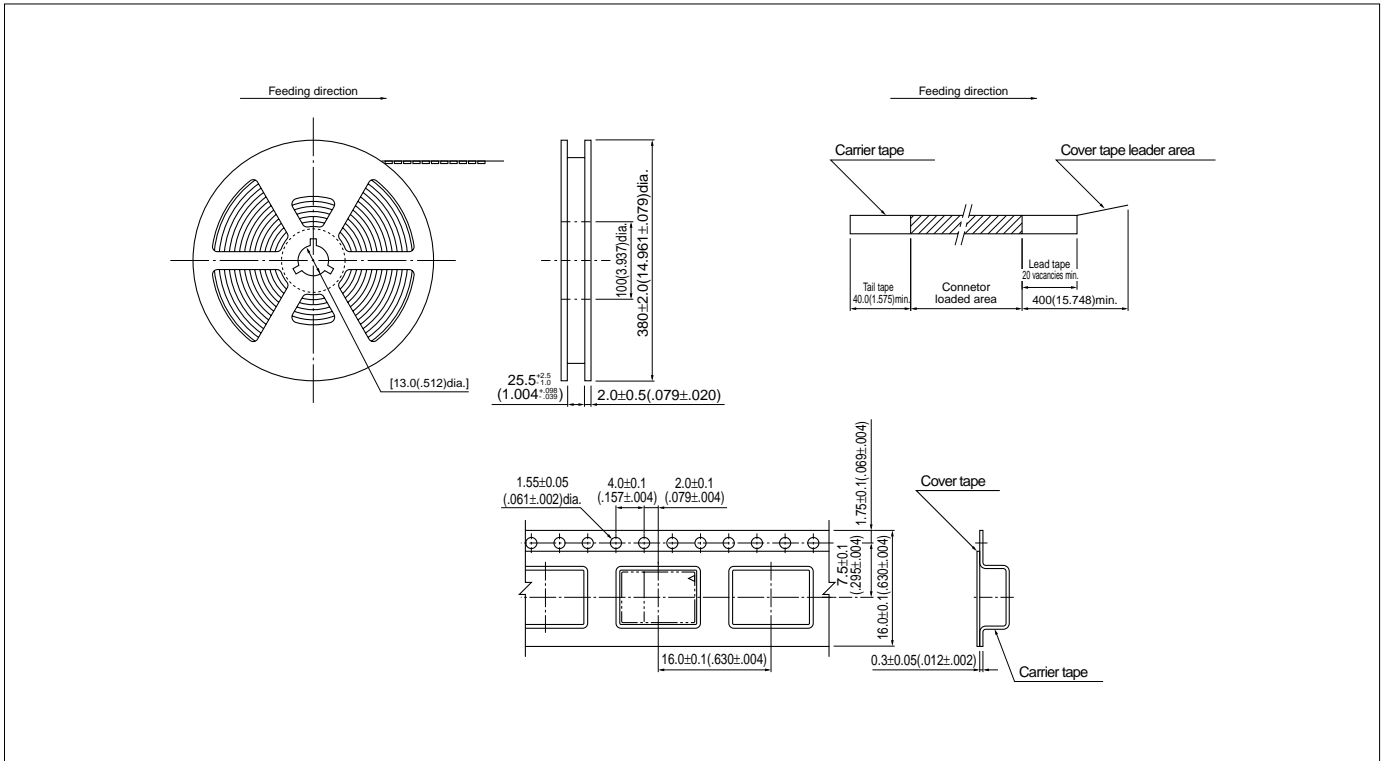

Note:

1. Specifications conform to JIS C 0806. The tape width, connector loading recess square hole dimensions, etc. are determined by the number of circuits and external shape of the connector to be loaded.
2. Specifications are subject to change without prior notice.

PC board layout (viewed from component side) and Assembly layout

