

REVISIONS			
LT	DESCRIPTION	DATE (YR-MO-DA)	APPROVED
A	Add case outlines 5, 6, 7 and 8. - tmh	00-06-08	Monica L. Poelking
B	Add device types 09 – 15. - tmh	00-07-26	Thomas M. Hess
C	Add die requirements and appendix A. – tmh	00-09-01	Monica L. Poelking
D	Change dimensions for case outline 8. Boileplate update. phn	01-08-14	Thomas M. Hess
E	Add device types 16 - 29. - phn	02-03-08	Thomas M. Hess

REV	E	E	E	E	E	E	E													
SHEET	95	96	97	98	99	100	101													
REV	E	E	E	E	E	E	E	E	E	E	E	E	E	E	E	E	E	E	E	E
SHEET	75	76	77	78	79	80	81	82	83	84	85	86	87	88	89	90	91	92	93	94
REV	E	E	E	E	E	E	E	E	E	E	E	E	E	E	E	E	E	E	E	E
SHEET	55	56	57	58	59	60	61	62	63	64	65	66	67	68	69	70	71	72	73	74
REV	E	E	E	E	E	E	E	E	E	E	E	E	E	E	E	E	E	E	E	E
SHEET	35	36	37	38	39	40	41	42	43	44	45	46	47	48	49	50	51	52	53	54
REV	A	A	A	A	A	A	D	D	D	D	E	E	E	E	E	E	E	E	E	E
SHEET	15	16	17	18	19	20	21	22	23	24	25	26	27	28	29	30	31	32	33	34

REV STATUS	REV	E	E	E	E	A	D	A	A	A	A	A	A	A	A	A	A	A	A	A
OF SHEETS	SHEET	1	2	3	4	5	6	7	8	9	10	11	12	13	14					

PMIC N/A	PREPARED BY Thomas M. Hess	<p align="center">DEFENSE SUPPLY CENTER COLUMBUS COLUMBUS, OHIO 43216 http://www.dscc.dla.mil</p> <p align="center">MICROCIRCUIT, DIGITAL, CMOS, MG2, GATE ARRAY, MONOLITHIC SILICON</p>																	
<p align="center">STANDARD MICROCIRCUIT DRAWING</p> <p align="center">THIS DRAWING IS AVAILABLE FOR USE BY ALL DEPARTMENTS AND AGENCIES OF THE DEPARTMENT OF DEFENSE</p> <p align="center">AMSC N/A</p>	CHECKED BY Thomas M. Hess																		
	APPROVED BY Monica L. Poelking																		
	DRAWING APPROVAL DATE 00-04-04																		
	REVISION LEVEL E	SIZE A	CAGE CODE 67268	5962-00B02															
		SHEET 1 OF 101																	

1. SCOPE

[查询"5962-00B02"供应商](#)

1.1 Scope - This drawing documents two product assurance class levels consisting of high reliability (device classes Q and M) and space application (device class V). A choice of case outlines and lead finishes are available and are reflected in the Part or Identifying Number (PIN). When available, a choice of Radiation Hardness Assurance (RHA) levels are reflected in the PIN.

1.2 PIN. The PIN is as shown in the following example:

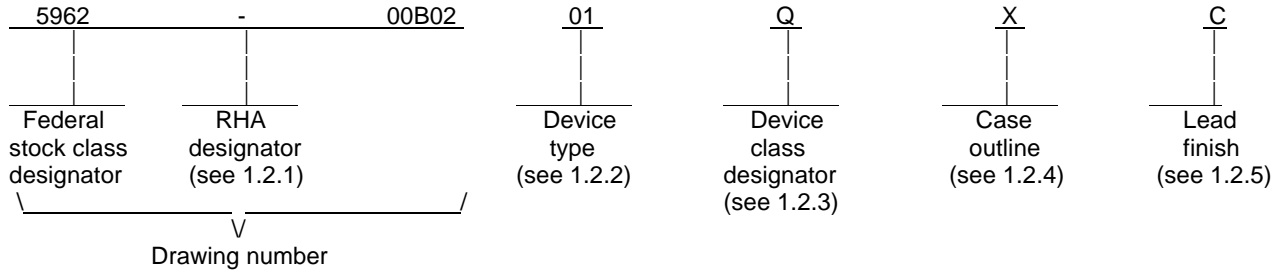

1.2.1 RHA designator. Device classes Q and V RHA marked devices meet the MIL-PRF-38535 specified RHA levels and are marked with the appropriate RHA designator. Device class M RHA marked devices meet the MIL-PRF-38535, appendix A specified RHA levels and are marked with the appropriate RHA designator. A dash (-) indicates a non-RHA device.

1.2.2 Device type(s). The device type(s) identify the circuit function as follows:

<u>Device type</u>	<u>Generic number</u>	<u>Circuit function</u>
01	MG2044E	44,000 MG2RT gates available
02	MG2091E	91,000 MG2RT gates available
03	MG2140E	140,000 MG2RT gates available
04	MG2194E	194,000 MG2RT gates available
05	MG2265E	265,000 MG2RT gates available
06	MG2360E	360,000 MG2RT gates available
07	MG2480E	480,000 MG2RT gates available
08	MG2700E	700,000 MG2RT gates available
09	MG2044	44,000 MG2 gates available
10	MG2091	91,000 MG2 gates available
11	MG2140	140,000 MG2 gates available
12	MG2194	194,000 MG2 gates available
13	MG2265	265,000 MG2 gates available
14	MG2360	360,000 MG2 gates available
15	MG2480	480,000 MG2 gates available
16	MG2M044E	composite 44,000 MG2RT gates available
17	MG2M091E	composite 91,000 MG2RT gates available
18	MG2M140E	composite 140,000 MG2RT gates available
19	MG2M194E	composite 194,000 MG2RT gates available
20	MG2M265E	composite 265,000 MG2RT gates available
21	MG2M360E	composite 360,000 MG2RT gates available
22	MG2M480E	composite 480,000 MG2RT gates available
23	MG2M044	composite 44,000 MG2 gates available
24	MG2M091	composite 91,000 MG2 gates available
25	MG2M140	composite 140,000 MG2 gates available
26	MG2M194	composite 194,000 MG2 gates available
27	MG2M265	composite 265,000 MG2 gates available
28	MG2M360	composite 360,000 MG2 gates available
29	MG2M480	composite 480,000 MG2 gates available

STANDARD MICROCIRCUIT DRAWING DEFENSE SUPPLY CENTER COLUMBUS COLUMBUS, OHIO 43216-5000	SIZE A		5962-00B02
		REVISION LEVEL E	SHEET 2

1.2.3 Device class designator. The device class designator is a single letter identifying the product assurance level as follows:

<u>Device class</u>	<u>Device requirements documentation</u>
M	Vendor self-certification to the requirements for MIL-STD-883 compliant, non-JAN class level B microcircuits in accordance with MIL-PRF-38535, appendix A
Q or V	Certification and qualification to MIL-PRF-38535

1.2.4 Case outline(s). The case outline(s) are as designated in MIL-STD-1835 and as follows:

<u>Outline letter</u>	<u>Descriptive designator</u>	<u>Terminals</u>	<u>Package style</u>
X	See Figure 1	132	Flatpack gull wing leads
Y	See Figure 1	160	Flatpack gull wing leads
Z	See Figure 1	196	Flatpack gull wing leads
U	See Figure 1	256	Flatpack unformed leads
T	See Figure 1	352	Quad flatpack with non-conductive tie bar
M	See Figure 1	84	Flatpack unformed leads
N	See Figure 1	100	Flatpack gull wing leads
4	CQCC2-F172	172	Flatpack unformed leads
5	See Figure 1	132	Flatpack unformed leads
6	See Figure 1	160	Flatpack unformed leads
7	See Figure 1	196	Flatpack unformed leads
8	See Figure 1	100	Flatpack unformed leads

1.2.5 Lead finish. The lead finish is as specified in MIL-PRF-38535 for device classes Q and V or MIL-PRF-38535, appendix A for device class M.

1.3 Absolute maximum ratings 1/ 2/

Supply voltage range (V_{DD}).....	-0.5 V to 7.0 V
Input voltage range (V_{IN}).....	-0.5 V to $V_{DD} + 0.5 V$ 3/
Input current (I_{IN})	
Signal pin	-10 mA to 10 mA
Power pin	-50 mA to 50 mA
Output short circuit current 4/	
$V_{OUT} = V_{DD}$	48 mA
$V_{OUT} = V_{SS}$	-36 mA
Lead temperature (soldering, 10 sec)	300°C 5/
Storage temperature.....	-65°C to 150°C
Maximum junction temperature (T_J)	175°C

1.4 Recommended operating conditions.

Supply voltage range.....	2.4 V to 5.5 V 6/
Ambient operating temperature (T_A)	-55°C to 125°C

- 1/ Stresses above the absolute maximum rating may cause permanent damage to the device. Extended operation at the maximum levels may degrade performance and affect reliability.
 2/ All voltages referenced to Ground unless otherwise specified.
 3/ $V_{DD} + 0.5 V$ shall not exceed 7.0 V.
 4/ The maximum output current of any single output in short condition for a maximum duration of 1 second.
 5/ Duration 10 s max at a distance not less than 1.6 mm.
 6/ This gate array device is capable of being configured with $V_{DD} = 3.3 V \pm 10\%$ or $V_{DD} = 5.0 V \pm 10\%$.

STANDARD MICROCIRCUIT DRAWING DEFENSE SUPPLY CENTER COLUMBUS COLUMBUS, OHIO 43216-5000	SIZE A		5962-00B02
		REVISION LEVEL E	SHEET 3

1.5. Digital logic testing for device classes Q and V.
Fault coverage measurement of manufacturing
 logic tests (MIL-STD-883, test method 5012) As specified in the AID

2. APPLICABLE DOCUMENTS

2.1 Government specification, standards, and handbooks. The following specification, standards, and handbooks form a part of this drawing to the extent specified herein. Unless otherwise specified, the issues of these documents are those listed in the issue of the Department of Defense Index of Specifications and Standards (DoDISS) and supplement thereto, cited in the solicitation.

SPECIFICATION

DEPARTMENT OF DEFENSE

MIL-PRF-38535 - Integrated Circuits, Manufacturing, General Specification for.

STANDARDS

DEPARTMENT OF DEFENSE

MIL-STD-883 - Test Method Standard Microcircuits.
 MIL-STD-1835 - Interface Standard Electronic Component Case Outlines.

HANDBOOKS

DEPARTMENT OF DEFENSE

MIL-HDBK-103 - List of Standard Microcircuit Drawings (SMD's).
 MIL-HDBK-780 - Standard Microcircuit Drawings.

(Unless otherwise indicated, copies of the specification, standards, and handbooks are available from the Standardization Document Order Desk, 700 Robbins Avenue, Building 4D, Philadelphia, PA 19111-5094.)

2.3 Order of precedence. In the event of a conflict between the text of this drawing and the references cited herein, the text of this drawing takes precedence. Nothing in this document, however, supersedes applicable laws and regulations unless a specific exemption has been obtained.

3. REQUIREMENTS

3.1 Item requirements. The individual item requirements for device classes Q and V shall be in accordance with MIL-PRF-38535 and as specified herein or as modified in the device manufacturer's Quality Management (QM) plan. The modification in the QM plan shall not affect the form, fit, or function as described herein. The individual item requirements for device class M shall be in accordance with MIL-PRF-38535, appendix A for non-JAN class level B devices and as specified herein.

3.1.1 Microcircuit die. For the requirements for microcircuit die, see appendix A to this document.

3.2 Design, construction, and physical dimensions. The design, construction, and physical dimensions shall be as specified in MIL-PRF-38535 and herein for device classes Q and V or MIL-PRF-38535, appendix A and herein for device class M.

STANDARD MICROCIRCUIT DRAWING DEFENSE SUPPLY CENTER COLUMBUS COLUMBUS, OHIO 43216-5000	SIZE A		5962-00B02
		REVISION LEVEL E	SHEET 4

3.3 AID requirements. All AIDs written against this SMD shall be sent to DSCC-VA. The following items shall be provided to the device manufacturer by the customer as part of an AID.

3.3.1 Terminal connections and pin assignments.

3.3.2 Package type (see 1.2.4).

3.3.3 Functional block diagram (or equivalent VHDL behavioral description).

3.3.4 Functional description terms and symbols.

3.3.5 Logic diagram (or equivalent structural VHDL description or mutually agreed to net list).

3.3.6 Pin function description.

3.3.7 Design tape # or Design document name (i.e., net list).

3.3.8 Design functional tape # or name.

3.3.9 Test functional tape # or name.

3.3.10 Timing diagram(s).

3.3.11 Fault coverage measurement of manufacturing logic tests.

3.3.12 Burn-in circuit.

3.3.13 ESD class and voltage.

3.3.14 Device electrical performance characteristics (additions to Table I). Device electrical performance characteristics shall include dc parametric, functional, ac parameters and any other data which would be considered required by a design engineer. All electrical performance characteristics apply over the full recommended ambient operating temperature range and specified test load conditions.

3.3.15 Maximum power dissipation. Maximum power dissipation shall be in accordance with the application specific design.

3.4 Electrical performance characteristics and postirradiation parameter limits. Unless otherwise specified herein, the electrical performance characteristics and postirradiation parameter limits are as specified in table I and shall apply over the full case operating temperature range.

3.5 Electrical test requirements. The electrical test requirements shall be the subgroups specified in table II. The electrical tests for each subgroup are defined in table I.

3.6 Marking. The part shall be marked with the PIN listed in 1.2 herein. In addition, the manufacturer's PIN may also be marked as listed in MIL-HDBK-103. For packages where marking of the entire SMD PIN number is not feasible due to space limitations, the manufacturer has the option of not marking the "5962-" on the device. For RHA product using this option, the RHA designator shall still be marked. Marking for device classes Q and V shall be in accordance with MIL-PRF-38535. Marking for device class M shall be in accordance with MIL-PRF-38535, appendix A. The AID number shall be added to the marking by the manufacturer.

3.6.1 Certification/compliance mark. The certification mark for device classes Q and V shall be a "QML" or "Q" as required in MIL-PRF-38535. The compliance mark for device class M shall be a "C" as required in MIL-PRF-38535, appendix A.

3.7 Certificate of compliance. For device classes Q and V, a certificate of compliance shall be required from a QML-38535 listed manufacturer in order to supply to the requirements of this drawing (see 6.6.1 herein). For device class M, a certificate of compliance shall be required from a manufacturer in order to be listed as an approved source of supply in MIL-HDBK-103 (see 6.6.2 herein). The certificate of compliance submitted to DSCC-VA prior to listing as an approved source of supply for this drawing shall affirm that the manufacturer's product meets, for device classes Q and V, the requirements of MIL-PRF-38535 and herein or for device class M, the requirements of MIL-PRF-38535, appendix A and herein.

STANDARD MICROCIRCUIT DRAWING DEFENSE SUPPLY CENTER COLUMBUS COLUMBUS, OHIO 43216-5000	SIZE A		5962-00B02
		REVISION LEVEL A	SHEET 5

3.8 Certificate of conformance. A certificate of conformance as required for device classes Q and V in MIL-PRF-38535 or for device class M in MIL-PRF-38535, appendix A shall be provided with each lot of microcircuits delivered to this drawing.

3.9 Notification of change for device class M. For device class M, notification to DSCC-VA of change of product (see 6.2 herein) involving devices acquired to this drawing is required for any change as defined in MIL-PRF-38535, appendix A.

3.10 Verification and review for device class M. For device class M, DSCC, DSCC's agent, and the acquiring activity retain the option to review the manufacturer's facility and applicable required documentation. Offshore documentation shall be made available onshore at the option of the reviewer.

3.11 Microcircuit group assignment for device class M. Device class M devices covered by this drawing shall be in microcircuit group number 123 (see MIL-PRF-38535, appendix A).

STANDARD MICROCIRCUIT DRAWING DEFENSE SUPPLY CENTER COLUMBUS COLUMBUS, OHIO 43216-5000	SIZE A		5962-00B02
		REVISION LEVEL D	SHEET 6

TABLE I. Electrical performance characteristics.

Test	Symbol	Conditions -55°C ≤ T _C ≤ +125°C V _{DD} = 5.0 V ± 10 % unless otherwise specified	Group A subgroups	Device type	Limits		Unit
					Min	Max	
Input Clamp Voltage to GND <u>1/</u>	V _{IC}	I _{OH} = -300 μA	1, 2, 3	All	-1.2	-0.2	V
Low Level Input Current <u>2/</u>	I _{IL}	V _{IN} = GND, V _{DD} = 5.5 V	1, 2, 3	All	-5	-	μA
Low Level Input Current, Pull-up <u>2/</u>	I _{ILPU}	V _{IN} = GND, V _{DD} = 5.5 V	1, 2, 3	All	-120	-	μA
Low Level Input Current, Pull-down <u>2/</u>	I _{LLPD}	V _{IN} = GND, V _{DD} = 5.5 V	1, 2, 3	All	-5	-	μA
High Level Input Current <u>2/</u>	I _{IH}	V _{IN} = V _{DD} = 5.5 V	1, 2, 3	All	-	5	μA
High Level Input Current, Pull-up <u>2/</u>	I _{IHPU}	V _{IN} = V _{DD} = 5.5 V	1, 2, 3	All	-	5	μA
High Level Input Current, Pull-down <u>2/</u>	I _{IHPD}	V _{IN} = V _{DD} = 5.5 V	1, 2, 3	All	-	330	μA
Output Leakage Low Current <u>2/</u>	I _{OZL}	Outputs disabled V _{OUT} = GND	1, 2, 3	All	-5		μA
Output Leakage High Current Pull-down Output <u>2/</u>	I _{OZHPD}	Outputs disabled V _{OUT} = V _{DD}	1, 2, 3	All	-	330	μA
Output Leakage Low Current Pull-up Output <u>2/</u>	I _{OZLPU}	Outputs disabled V _{OUT} = GND	1, 2, 3	All	-120	-	μA
Output Leakage High Current <u>2/</u>	I _{OZH}	Outputs disabled V _{OUT} = V _{DD}	1, 2, 3	All	-	5	μA
Low Level Input Voltage <u>1/</u>	V _{IL}	Functional verification	1, 2, 3	All	-	0.8	V
Low Level Output Voltage BUF <u>2/</u>	V _{OL1}	V _{DD} = 4.5 V I _{OL} = +3 mA	1, 2, 3	All	-	0.4	V
Low Level Output Voltage BUF <u>2/</u>	V _{OL2}	V _{DD} = 4.5 V I _{OL} = +6 mA	1, 2, 3	All	-	0.4	V
Low Level Output Voltage BUF <u>2/</u>	V _{OL3}	V _{DD} = 4.5 V I _{OL} = +12 mA	1, 2, 3	All	-	0.4	V
High Level Output Voltage BUF <u>2/</u>	V _{OH1}	V _{DD} = 4.5 V I _{OH} = -3 mA	1, 2, 3	All	3.9	-	V
High Level Output Voltage BUF <u>2/</u>	V _{OH2}	V _{DD} = 4.5 V I _{OH} = -6 mA	1, 2, 3	All	3.9	-	V

See notes at end of table.

STANDARD MICROCIRCUIT DRAWING DEFENSE SUPPLY CENTER COLUMBUS COLUMBUS, OHIO 43216-5000	SIZE A		5962-00B02
		REVISION LEVEL A	SHEET 7

TABLE I. Electrical performance characteristics.- Continued.

[查询"5962-00B02"供应商](#)

Test	Symbol	Conditions -55°C ≤ T _C ≤ +125°C V _{DD} = 5.0 V ± 10 % unless otherwise specified	Group A subgroups	Device type	Limits		Unit
					Min	Max	
High Level Output Voltage BUF <u>2/</u>	V _{OH3}	V _{DD} = 4.5 V I _{OH} = -12 mA	1, 2, 3	All	3.9	-	V
Schmitt trigger positive threshold CMOS input TTL input <u>3/</u>	V _{T+}		1, 2, 3		-	2.8 1.5	V
Schmitt trigger negative threshold CMOS input TTL input <u>3/</u>	V _{T-}		1, 2, 3		1.2 1.0	-	V
High Level Input Voltage <u>1/</u>	V _{IH}	Functional verification	1, 2, 3	All	2.2	-	V
Input Capacitance <u>3/</u>	C _I	V _{DD} = 0 V	4	All		15	pF
Output Capacitance <u>3/</u>	C _{IO}	V _{DD} = 0 V	4	All		15	pF

See notes at end of table.

STANDARD MICROCIRCUIT DRAWING DEFENSE SUPPLY CENTER COLUMBUS COLUMBUS, OHIO 43216-5000	SIZE A		5962-00B02
		REVISION LEVEL A	SHEET 8

TABLE I. Electrical performance characteristics.[查询"5962-00B02"供应商](#)

Test	Symbol	Conditions -55°C ≤ T _C ≤ +125°C V _{DD} = 3.3 V ± 10 % unless otherwise specified	Group A subgroups	Device type	Limits		Unit
					Min	Max	
Input Clamp Voltage to GND <u>1/</u>	V _{IC}	I _{OH} = -300 μA	1, 2, 3	All	-1.2	-0.2	V
Low Level Input Current <u>2/</u>	I _{IL}	V _{IN} = GND, V _{DD} = 3.3 V	1, 2, 3	All	-1	-	μA
Low Level Input Current, Pull-up <u>2/</u>	I _{ILPU}	V _{IN} = GND, V _{DD} = 3.3V	1, 2, 3	All	-60	-	μA
Low Level Input Current, Pull-down <u>2/</u>	I _{LLPD}	V _{IN} = GND, V _{DD} = 3.3 V	1, 2, 3	All	-1	-	μA
High Level Input Current <u>2/</u>	I _{IH}	V _{IN} = V _{DD} = 3.3 V	1, 2, 3	All	-	1	μA
High Level Input Current, Pull-up <u>2/</u>	I _{IHPU}	V _{IN} = V _{DD} = 3.3 V	1, 2, 3	All	-	1	μA
High Level Input Current, Pull-down <u>2/</u>	I _{IHPD}	V _{IN} = V _{DD} = 3.3 V	1, 2, 3	All	-	150	μA
Output Leakage Low Current <u>2/</u>	I _{OZL}	Outputs disabled V _{OUT} = GND	1, 2, 3	All	-1		μA
Output Leakage High Current Pull-down Output <u>2/</u>	I _{OZHPD}	Outputs disabled V _{OUT} = V _{DD}	1, 2, 3	All	-	150	μA
Output Leakage Low Current Pull-up Output <u>2/</u>	I _{OZLPU}	Outputs disabled V _{OUT} = GND	1, 2, 3	All	-60	-	μA
Output Leakage High Current <u>2/</u>	I _{OZH}	Outputs disabled V _{OUT} = V _{DD}	1, 2, 3	All	-	1	μA
Low Level Input Voltage <u>1/</u>	V _{IL}	Functional verification	1, 2, 3	All	-	0.8	V
Low Level Output Voltage BUF <u>2/</u>	V _{OL1}	V _{DD} = 3.3 V I _{OL} = +1.5 mA	1, 2, 3	All	-	0.4	V
Low Level Output Voltage BUF <u>2/</u>	V _{OL2}	V _{DD} = 3.3 V I _{OL} = +3 mA	1, 2, 3	All	-	0.4	V
Low Level Output Voltage BUF <u>2/</u>	V _{OL3}	V _{DD} = 3.3 V I _{OL} = +6 mA	1, 2, 3	All	-	0.4	V
High Level Output Voltage BUF <u>2/</u>	V _{OH1}	V _{DD} = 2.7 V I _{OH} = -1 mA	1, 2, 3	All	2.4	-	V
High Level Output Voltage BUF <u>2/</u>	V _{OH2}	V _{DD} = 2.7 V I _{OH} = -2 mA	1, 2, 3	All	2.4	-	V

See notes at end of table.

**STANDARD
MICROCIRCUIT DRAWING**
DEFENSE SUPPLY CENTER COLUMBUS
COLUMBUS, OHIO 43216-5000

SIZE
A

REVISION LEVEL
A

5962-00B02

SHEET

9

TABLE I. Electrical performance characteristics. - Continued.

[查询"5962-00B02"供应商](#)

Test	Symbol	Conditions -55°C ≤ T _C ≤ +125°C V _{DD} = 3.3 V ± 10 % unless otherwise specified	Group A subgroups	Device type	Limits		Unit
					Min	Max	
High Level Output Voltage BU2 <u>2/</u>	V _{OH3}	V _{DD} = 2.7 V I _{OH} = -4 mA	1, 2, 3	All	2.4	-	V
Schmitt trigger positive threshold CMOS input TTL input <u>3/</u>	V _{T+}		1, 2, 3		-	1.5 1.1	V
Schmitt trigger negative threshold CMOS input TTL input <u>3/</u>	V _{T-}		1, 2, 3		0.8 0.2	-	V
High Level Input Voltage <u>1/</u>	V _{IH}	Functional verification	1, 2, 3	All	2.2	-	V
Input Capacitance <u>3/</u>	C _I	V _{DD} = 0 V	4	All		15	pF
Output Capacitance <u>3/</u>	C _{IO}	V _{DD} = 0 V	4	All		15	pF

1/ Forcing conditions of the functional test, assure that these limits are met, but they will not be individually recorded.

2/ Read & Record measurements in accordance with MIL-PRF-38535.

3/ Tested at initial design and after major process changes, otherwise guaranteed.

STANDARD MICROCIRCUIT DRAWING DEFENSE SUPPLY CENTER COLUMBUS COLUMBUS, OHIO 43216-5000	SIZE A		5962-00B02
		REVISION LEVEL A	SHEET 10

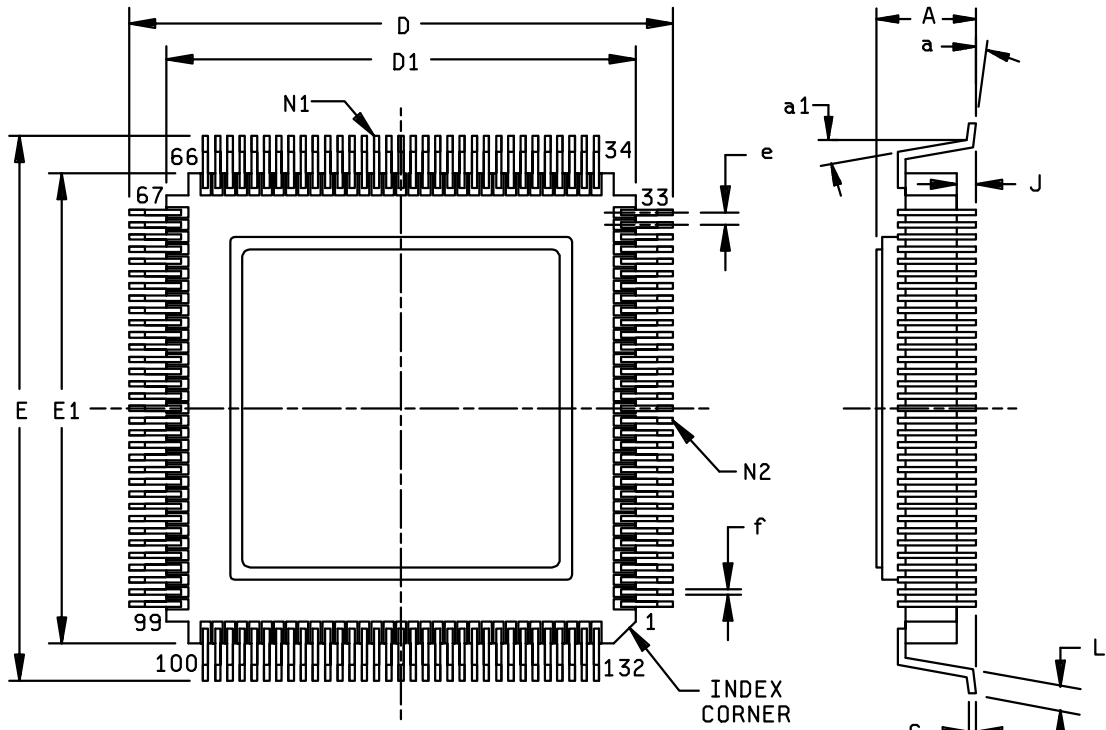

	MM		INCH	
	Min	Max	Min	Max
A	2.46	3.12	.097	.123
C	0.152 TYP		.006 TYP	
D	27.36	28.26	1.077	1.113
D1	24.00	24.38	.945	.960
E	27.36	28.26	1.077	1.113
E1	24.00	24.38	.945	.960
e	0.635 BSC		.025 BSC	
f	0.20 REF		.008 REF	
J	0.15	0.30	.006	.012
L	0.61	1.01	.024	.040
N1	33		33	
N2	33		33	
	a = 4° ± 4°		a1 = 5° ± 5°	

Figure 1. Case outlines - Continued

STANDARD MICROCIRCUIT DRAWING DEFENSE SUPPLY CENTER COLUMBUS COLUMBUS, OHIO 43216-5000	SIZE A		5962-00B02
		REVISION LEVEL A	SHEET 11

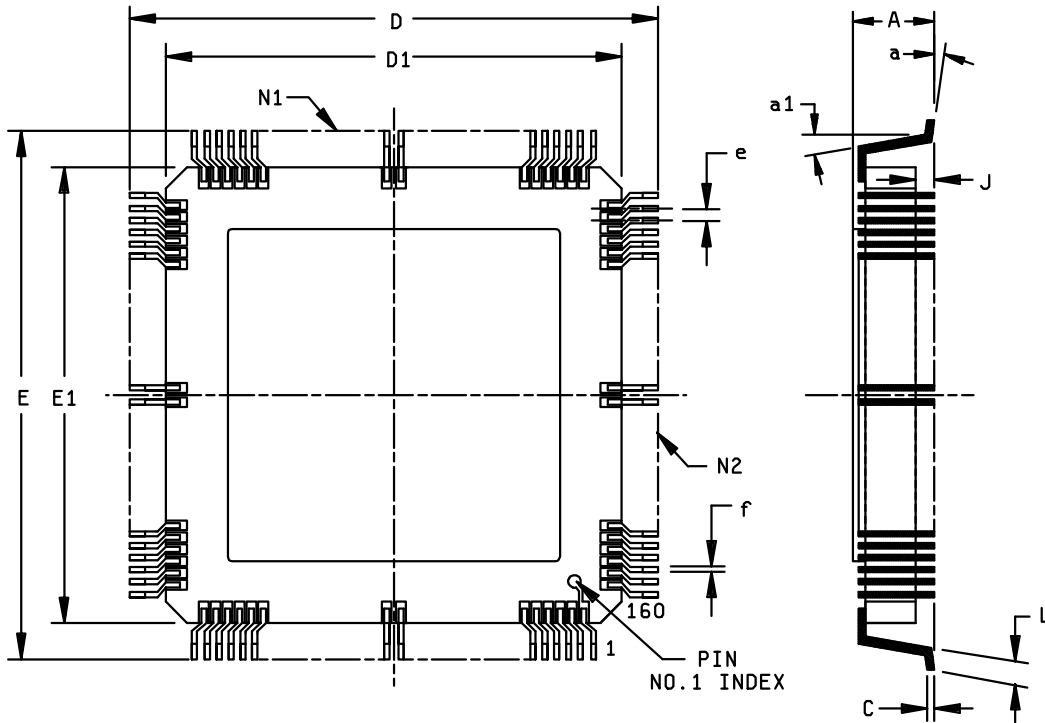

	MM		INCH	
	Min	Max	Min	Max
A	2.44	3.60	.096	.142
C	0.15	TYP	.006	TYP
D	31.93	32.67	1.257	1.286
D1	26.93	27.47	1.060	1.082
E	31.93	32.67	1.257	1.286
E1	26.93	27.47	1.060	1.082
e	0.65	BSC	.0256	BSC
f	0.30	REF	.012	REF
J	0.50	1.00	.020	.040
L	1.21	1.41	.047	.056
N1	40		40	
N2	40		40	
	a=2° ± 3°		a1=5° ± 3°	

Figure 1. Case outlines - Continued

STANDARD MICROCIRCUIT DRAWING DEFENSE SUPPLY CENTER COLUMBUS COLUMBUS, OHIO 43216-5000	SIZE A		5962-00B02
		REVISION LEVEL A	SHEET 12

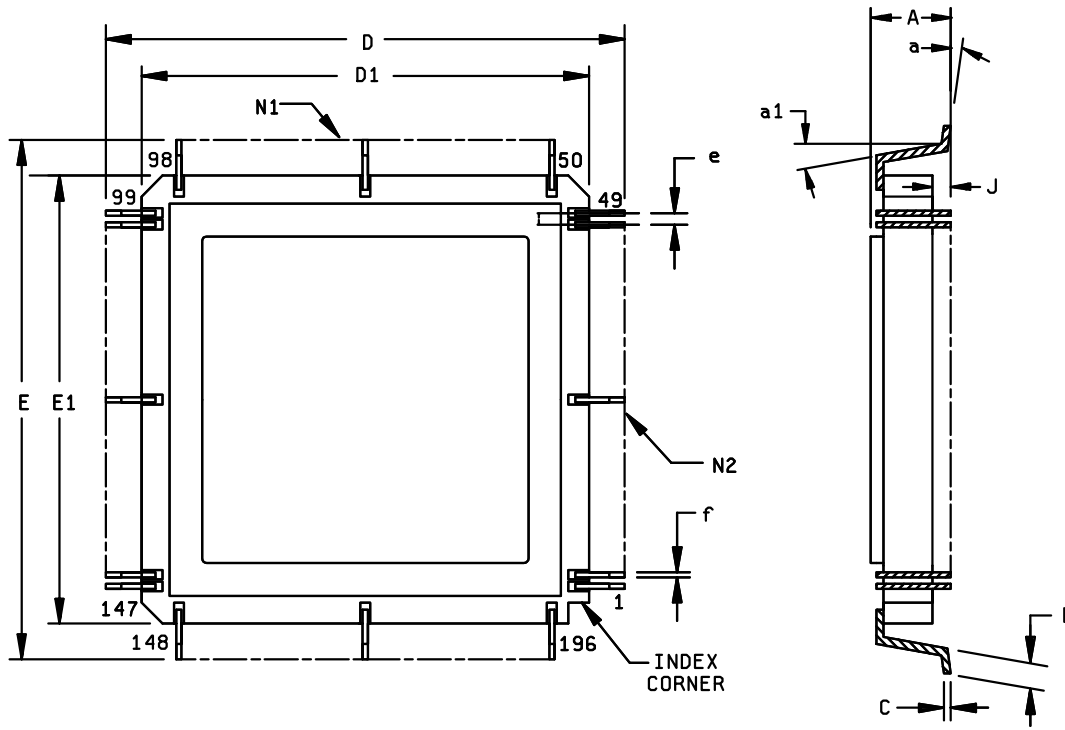

	MM		INCH	
	MIn	Max	MIn	Max
A	-	2.95	-	.116
C	0.20 TYP		.008 TYP	
D	-	39.75	-	1.565
D1	-	34.54	-	1.360
E	-	39.75	-	1.565
E1	-	34.54	-	1.360
e	0.635 BSC		.025 BSC	
f	0.28 REF		.011 REF	
J	0.15	0.30	.006	.012
L	0.61	1.01	.024	.040
N1	49		49	
N2	49		49	
	a=4°~ 4°		a1=5°~ 5°	

Figure 1. Case outlines - Continued

STANDARD MICROCIRCUIT DRAWING DEFENSE SUPPLY CENTER COLUMBUS COLUMBUS, OHIO 43216-5000	SIZE A		5962-00B02
		REVISION LEVEL A	SHEET 13

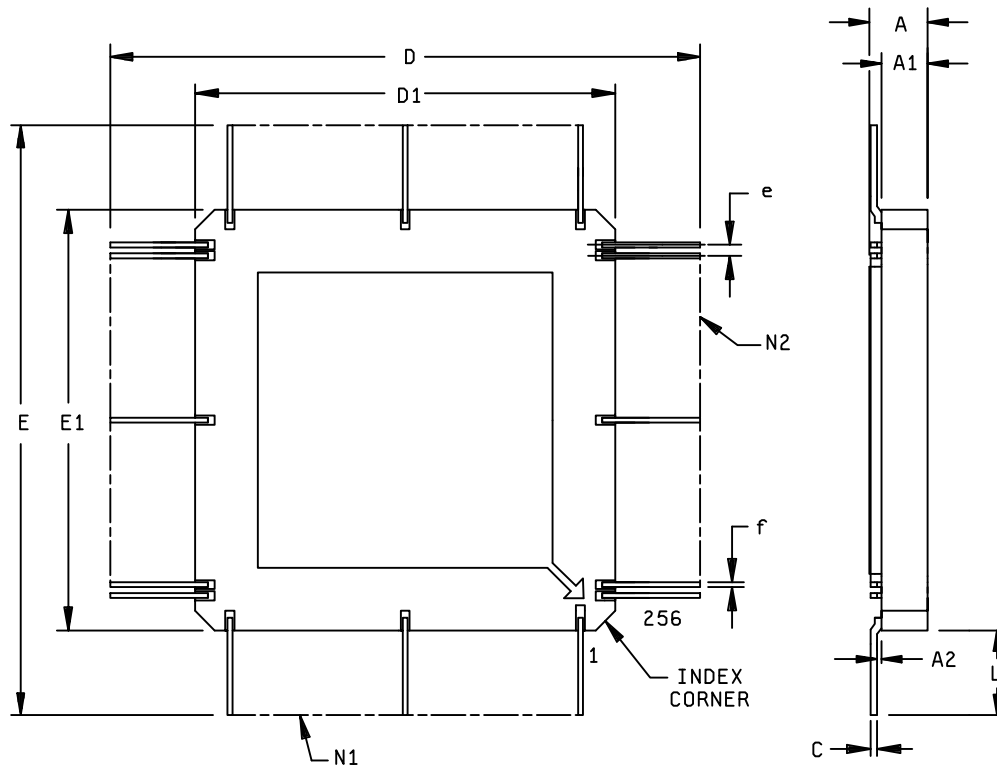

	MM		INCH	
	Min	Max	Min	Max
A	2.41	3.18	.095	.125
C	0.10	0.20	.004	.008
D	53.23	55.74	2.095	2.195
D1	36.83	37.34	1.450	1.470
E	53.23	55.74	2.095	2.195
E1	36.83	37.34	1.450	1.470
e	0.508 BSC		.020 BSC	
f	0.15	0.25	.006	.010
A1	2.06	2.56	.081	.101
A2	0.05	0.36	.002	.014
L	8.20	9.20	.323	.362
N1	64		64	
N2	64		64	

Figure 1. Case outlines - Continued

<p>STANDARD MICROCIRCUIT DRAWING DEFENSE SUPPLY CENTER COLUMBUS COLUMBUS, OHIO 43216-5000</p>	<p>SIZE A</p>		<p>5962-00B02</p>
		<p>REVISION LEVEL A</p>	<p>SHEET 14</p>

Case T

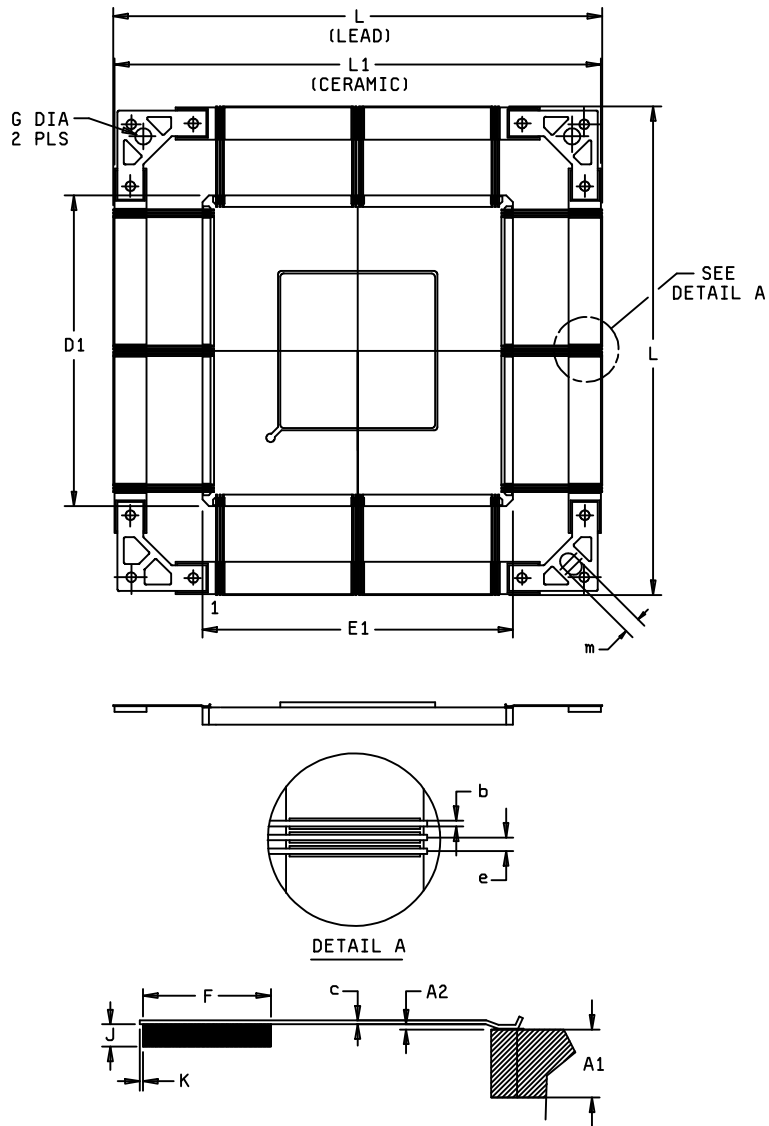

	mm		inch	
	min	max	min	max
m	2.50	2.65	0.098	0.104
L1	74.60	75.40	2.947	3.008
L	74.85	76.40	2.947	3.008
K	----	0.50	-----	0.020
J	0.75	1.05	0.029	0.041
G	2.50	2.60	0.098	0.104
F	4.50	5.50	0.177	0.217
e	0.50	BASIC	0.019685	BASIC
D1-E1	47.52	48.48	1.871	1.908
c	0.11	0.20	0.004	0.008
b1	0.18	0.22	0.007	0.009
b	0.19	0.25	0.007	0.010
A2	0.05	0.35	0.002	0.014
A1	2.35	3.15	0.092	0.124

Figure 1. Case outlines - Continued

<p>STANDARD MICROCIRCUIT DRAWING DEFENSE SUPPLY CENTER COLUMBUS COLUMBUS, OHIO 43216-5000</p>	<p>SIZE A</p>		<p>5962-00B02</p>
		<p>REVISION LEVEL A</p>	<p>SHEET 15</p>

[查询"5962-00B02"供应商](#)

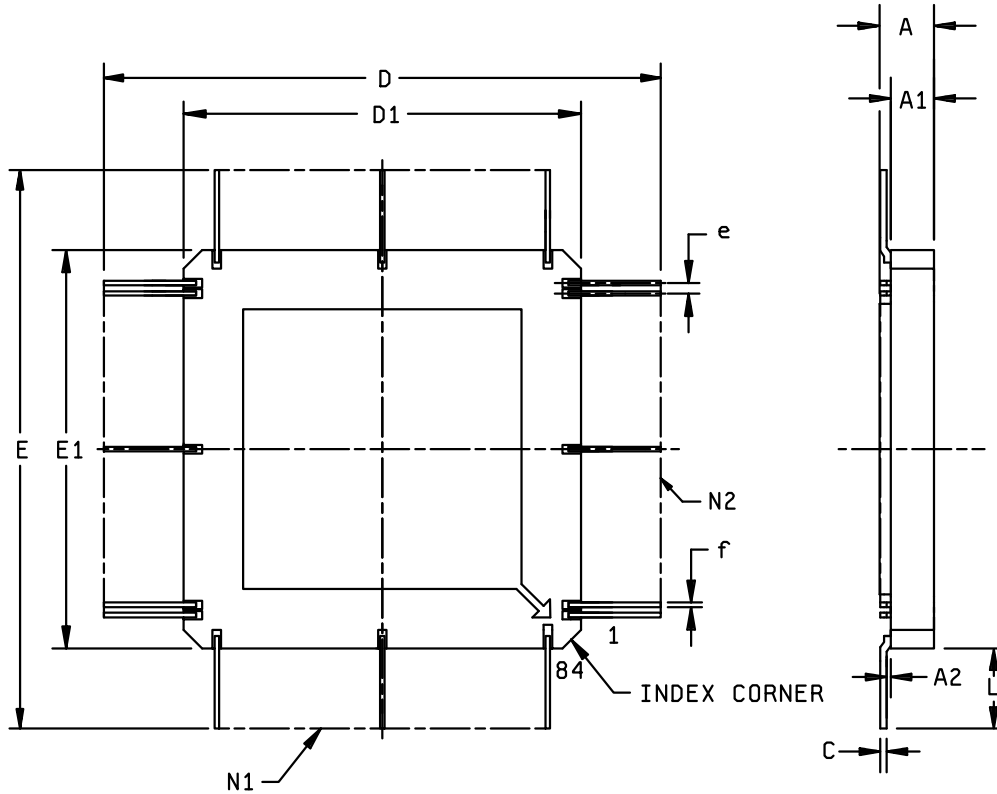

	MM		INCH	
	Min	Max	Min	Max
A	1.80	2.44	.071	.096
C	0.10	0.20	.004	.008
D	33.66	34.93	1.325	1.375
D1	16.38	16.64	0.645	0.655
E	33.65	34.93	1.325	1.375
E1	16.38	16.64	0.645	0.655
e	0.635 BSC		.025 BSC	
f	0.20	0.30	.008	.012
A1	1.17	1.80	.046	.071
A2	0.05	0.36	.002	.014
L	8.636	9.144	.340	.360
N1	21		21	
N2	21		21	

Figure 1. Case outlines - Continued

STANDARD MICROCIRCUIT DRAWING DEFENSE SUPPLY CENTER COLUMBUS COLUMBUS, OHIO 43216-5000	SIZE A		5962-00B02
		REVISION LEVEL A	SHEET 16

[查询"5962-00B02"供应商](#)

Case N

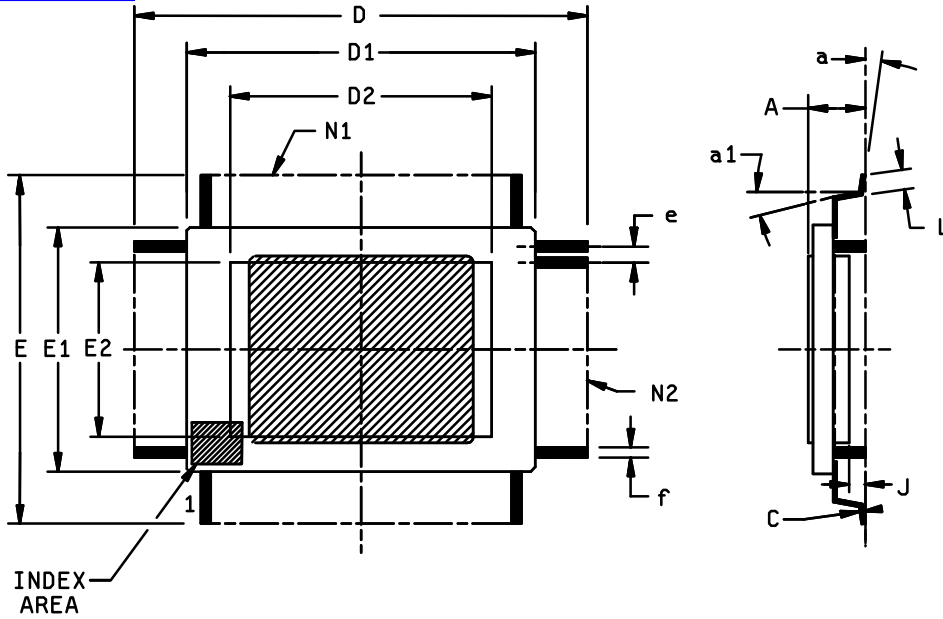

	MM		INCH	
	Min	Max	Min	Max
A	-	3.81	-	.150
C	0.15 TYP		.006 TYP	
D	23.76	24.48	.935	.964
D1	19.80	20.20	.780	.795
E	17.80	18.44	.701	.725
E1	13.85	14.15	.545	.557
e	0.65 BSC		.0256 BSC	
f	0.17	0.33	.0067	.013
J	0.10	0.36	.004	.014
L	0.61	1.01	.024	.040
D2	15.87	16.13	.624	.635
E2	9.87	10.13	.388	.399
	a = 4° ± 4°		a1 = 7° ± 7°	
	N1 = 30		N2 = 20	

Figure 1. Case outlines – Continued

STANDARD MICROCIRCUIT DRAWING DEFENSE SUPPLY CENTER COLUMBUS COLUMBUS, OHIO 43216-5000	SIZE A		5962-00B02
		REVISION LEVEL A	SHEET 17

查询"5962-00B02"供应商

Case 5

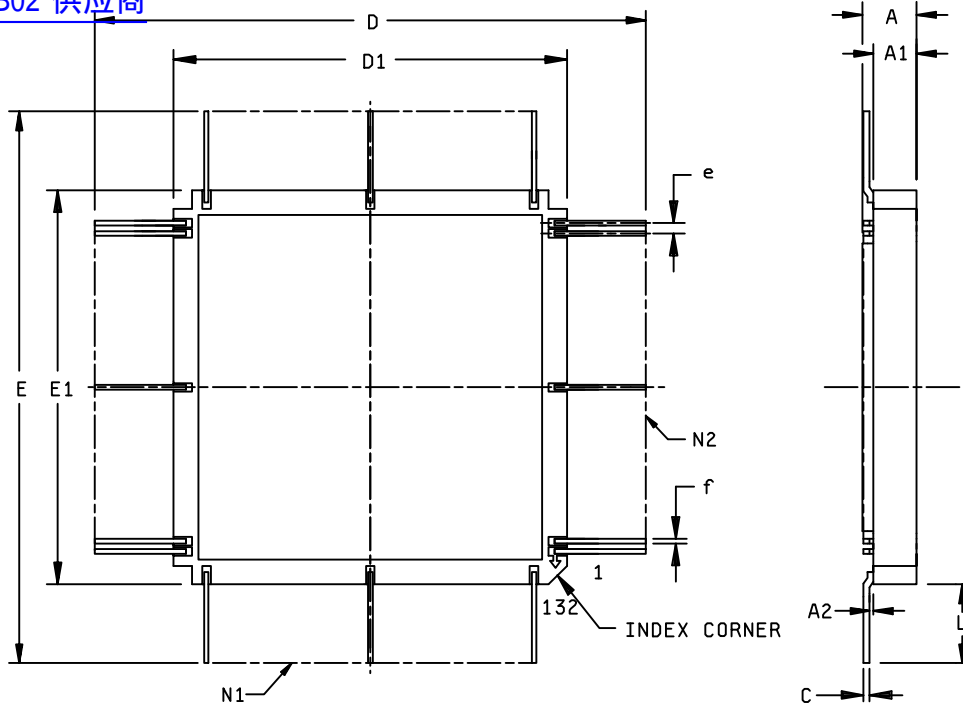

	Min	Max	Min	Max
A	2.36	2.82	.093	.111
C	0.152 TYP.		.006 TYP.	
D	37.00	39.38	1.457	1.550
D1	24.00	24.38	.945	.960
E	37.00	39.38	1.457	1.550
E1	24.00	24.38	.945	.960
e	0.635 BSC		.025 BSC	
f	0.200 REF		.008 REF	
A1	1.47	1.83	.058	.072
A2	0.203 REF		.008 REF	
L	6.50	7.50	.256	.295
N1	33		33	
N2	33		33	

Figure 1. Case outlines – Continued

STANDARD MICROCIRCUIT DRAWING DEFENSE SUPPLY CENTER COLUMBUS COLUMBUS, OHIO 43216-5000	SIZE A		5962-00B02
		REVISION LEVEL A	SHEET 18

查询"5962-00B02"供应商

Case 6

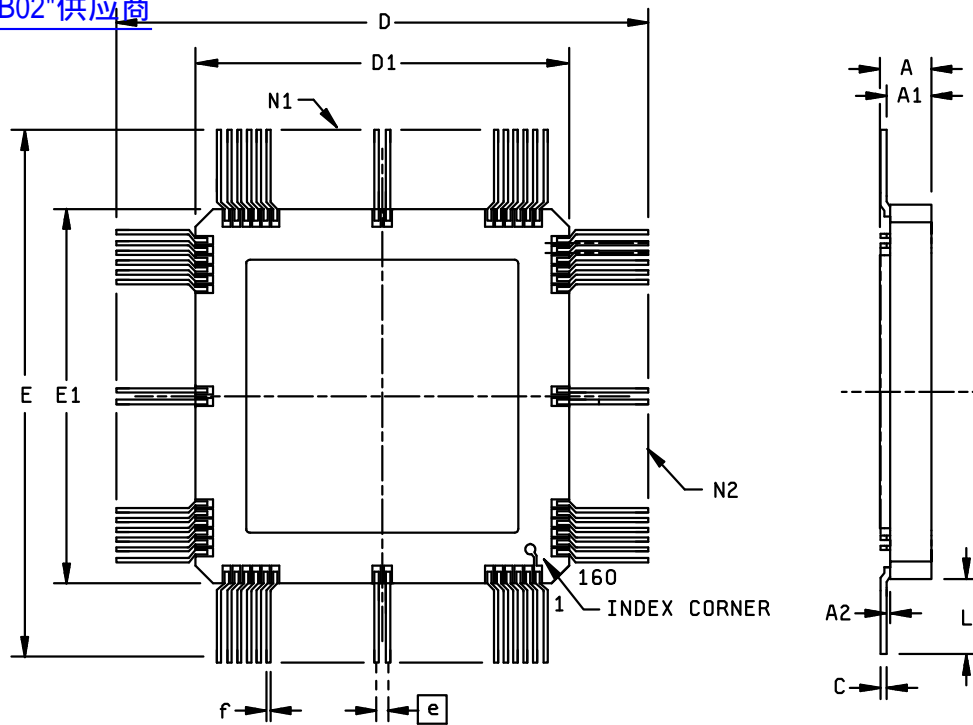

	mm		mils	
	Min	Max	Min	Max
A	1.96	2.66	.077	.105
C	0.10	0.20	.004	.008
D	37.90	39.30	1.492	1.548
D1	26.90	27.50	1.059	1.083
E	37.90	39.30	1.492	1.548
E1	26.90	27.50	1.059	1.083
e	0.650 BSC		.0256 BSC	
f	0.25	0.35	.010	.014
A1	1.70	2.10	.067	.083
A2	0.10	0.30	.004	.012
L	5.50	5.90	.216	.232
N1	40		40	
N2	40		40	

Figure 1. Case outlines – Continued

STANDARD MICROCIRCUIT DRAWING DEFENSE SUPPLY CENTER COLUMBUS COLUMBUS, OHIO 43216-5000	SIZE A		5962-00B02
		REVISION LEVEL A	SHEET 19

[查询"5962-00B02"供应商](#)

Case 7

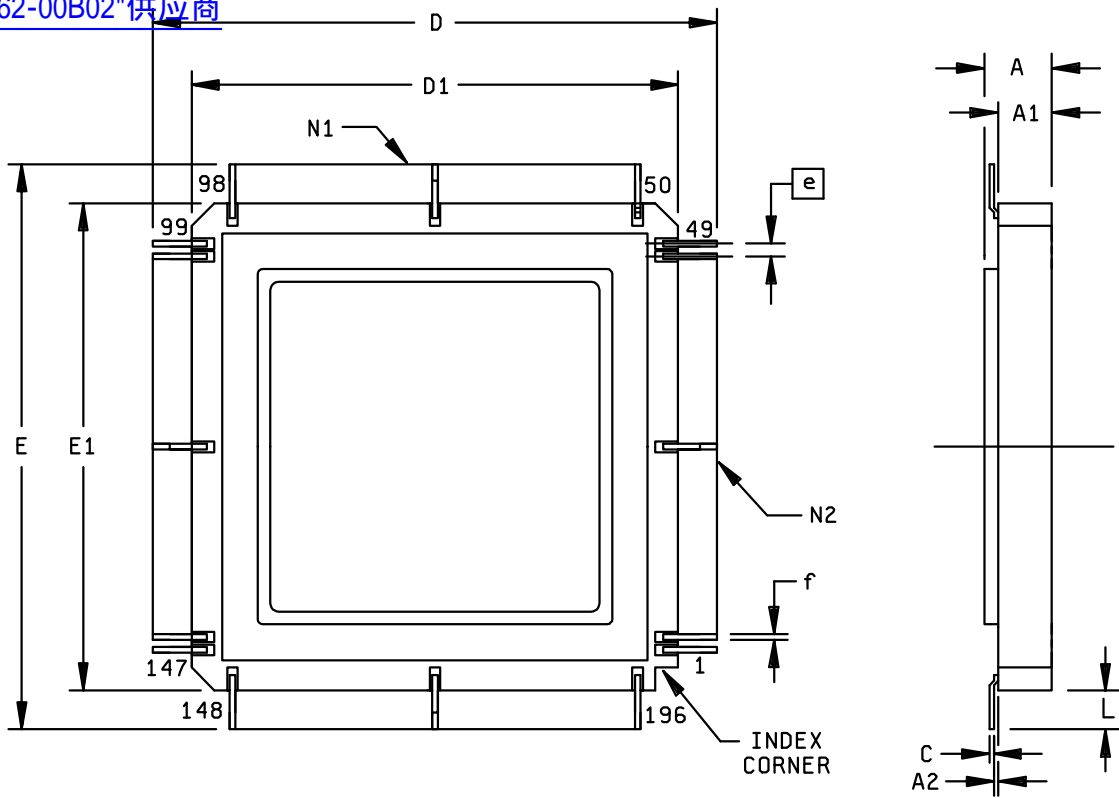

	Min	Max	Min	Max
A	2.13	2.65	.084	.104
A1	1.83	2.24	.072	.088
A2	0.203 REF		.008 REF	
C	0.102	0.203	.004	.008
D/E	46.73	47.94	1.840	1.887
D1/E1	34.03	34.54	1.340	1.360
e	0.635 BSC		.025 BSC	
f	0.20 REF		.008 REF	
L	6.35	6.70	.250	.264
N1	49		49	
N2	49		49	

Figure 1. Case outlines – Continued

STANDARD MICROCIRCUIT DRAWING DEFENSE SUPPLY CENTER COLUMBUS COLUMBUS, OHIO 43216-5000	SIZE A		5962-00B02
		REVISION LEVEL A	SHEET 20

查询"5962-00B02"供应商

Case 8

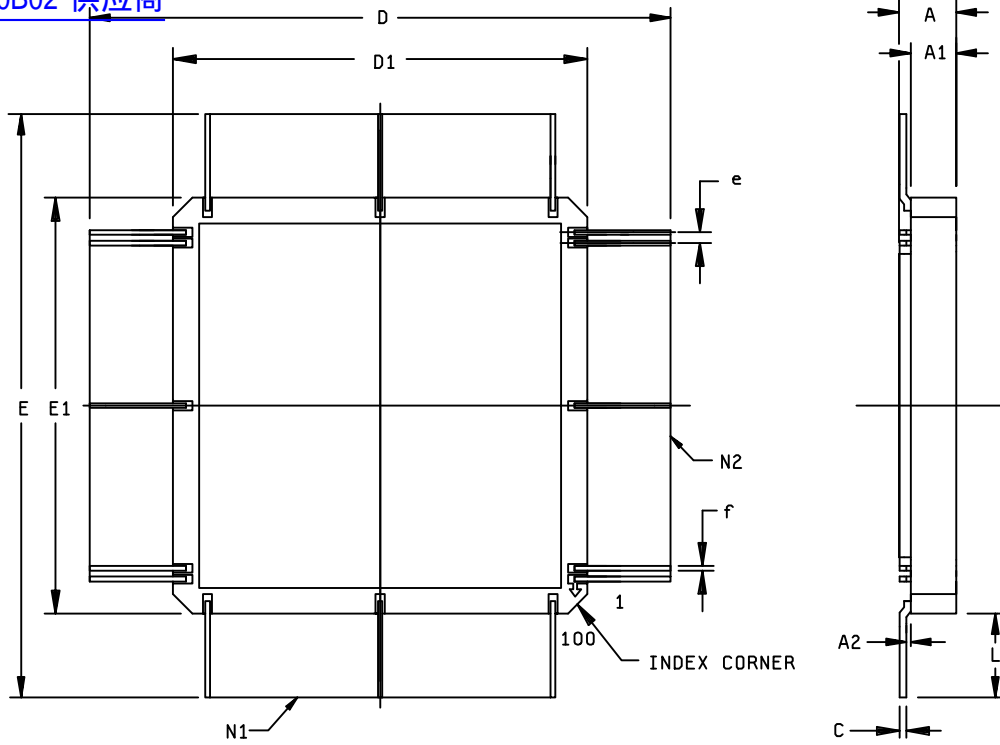

	Min	Max	Min	Max
A	2.21	2.67	.087	.105
C	0.15	0.20	.006	.008
D	33.80	35.30	1.331	1.390
D1	18.80	19.30	.740	.760
E	33.80	35.30	1.331	1.390
E1	18.80	19.30	.740	.760
e	0.635 BSC		.025 BSC	
f	0.254 REF		.010 REF	
A1	1.83	2.24	.072	.088
A2	0.203 REF		.008 REF	
L	7.50	8.00	.295	.315
N1	25		25	
N2	25		25	

Figure 1. Case outlines – Continued

STANDARD MICROCIRCUIT DRAWING DEFENSE SUPPLY CENTER COLUMBUS COLUMBUS, OHIO 43216-5000	SIZE A		5962-00B02
		REVISION LEVEL D	SHEET 21

4. QUALITY ASSURANCE PROVISIONS

[查询"5962-00B02"供应商](#)

4.1 Sampling and inspection For device classes Q and V, sampling and inspection procedures shall be in accordance with MIL-PRF-38535 or as modified in the device manufacturer's Quality Management (QM) plan. The modification in the QM plan shall not affect the form, fit, or function as described herein. For device class M, sampling and inspection procedures shall be in accordance with MIL-PRF-38535, appendix A.

4.2 Screening. For device classes Q and V, screening shall be in accordance with MIL-PRF-38535, and shall be conducted on all devices prior to qualification and technology conformance inspection. For device class M, screening shall be in accordance with method 5004 of MIL-STD-883, and shall be conducted on all devices prior to quality conformance inspection.

4.2.1 Additional criteria for device class M.

- a. Burn-in test, method 1015 of MIL-STD-883.
 - (1) Test condition is described in the AID. The test circuit shall be maintained by the manufacturer under document revision level control and shall be made available to the preparing or acquiring activity upon request. The test circuit shall specify the inputs, outputs, biases, and power dissipation, as applicable, in accordance with the intent specified in test method 1015.
 - (2) $T_A = +125^{\circ}\text{C}$, minimum.
- b. Interim and final electrical test parameters shall be as specified in table II herein.

4.2.2 Additional criteria for device classes Q and V.

- a. The burn-in test duration, test condition and test temperature, or approved alternatives shall be as specified in the device manufacturer's QM plan in accordance with MIL-PRF-38535. The burn-in test circuit shall be maintained under document revision level control of the device manufacturer's Technology Review Board (TRB) in accordance with MIL-PRF-38535 and shall be made available to the acquiring or preparing activity upon request. The test circuit shall specify the inputs, outputs, biases, and power dissipation, as applicable, in accordance with the intent specified in test method 1015 of MIL-STD-883.
- b. Interim and final electrical test parameters shall be as specified in table II herein.
- c. Additional screening for device class V beyond the requirements of device class Q shall be as specified in MIL-PRF-38535, appendix B.

4.3 Qualification inspection for device classes Q and V. Qualification inspection for device classes Q and V shall be in accordance with MIL-PRF-38535. Inspections to be performed shall be those specified in MIL-PRF-38535 and herein for groups A, B, C, D, and E inspections (see 4.4.1 through 4.4.4).

4.4 Conformance inspection. Technology conformance inspection for classes Q and V shall be in accordance with MIL-PRF-38535 including groups A, B, C, D, and E inspections and as specified herein. Quality conformance inspection for device class M shall be in accordance with MIL-PRF-38535, appendix A and as specified herein. Inspections to be performed for device class M shall be those specified in method 5005 of MIL-STD-883 and herein for groups A, B, C, D, and E inspections (see 4.4.1 through 4.4.4).

STANDARD MICROCIRCUIT DRAWING DEFENSE SUPPLY CENTER COLUMBUS COLUMBUS, OHIO 43216-5000	SIZE A		5962-00B02
		REVISION LEVEL D	SHEET 22

TABLE II. Electrical test requirements.

Test requirements	Subgroups (in accordance with MIL-STD-883, method 5005, table I)	Subgroups (in accordance with MIL-PRF-38535, table III)	
	Device class M	Device class Q	Device class V
Interim electrical parameters (see 4.2)	1, 7, 9	1, 7, 9	1, 7, 9
Final electrical parameters (see 4.2)	1, 2, 3, 7, 8, 9, 10, 11 <u>1/</u>	1, 2, 3, 7, 8, 9, 10, 11 <u>1/</u>	1, 2, 3, 7, 8, 9, 10, 11 <u>2/</u>
Group A test requirements (see 4.4)	1, 2, 3, 4, 7, 8, 9, 10, 11	1, 2, 3, 4, 7, 8, 9, 10, 11	1, 2, 3, 4, 7, 8, 9, 10, 11
Group C end-point electrical parameters (see 4.4)	1, 7, 9	1, 7, 9	1, 7, 9
Group D end-point electrical parameters (see 4.4)	1, 7, 9	1, 7, 9	1, 7, 9
Group E end-point electrical parameters (see 4.4)	1, 7, 9	1, 7, 9	1, 7, 9

1/ PDA applies to subgroup 1.
2/ PDA applies to subgroups 1 and 7.

4.4.1 Group A inspection.

- a. Tests shall be as specified in table II herein.
- b. For device class Q and V, subgroups 7 and 8 tests shall be sufficient to verify the functionality of the device as described in the AID.

4.4.2 Group C inspection. The group C inspection end-point electrical parameters shall be as specified in table II herein.

4.4.2.1 Additional criteria for device class M. Steady-state life test conditions, method 1005 of MIL-STD-883:

- a. Test condition as described in the AID. The test circuit shall be maintained by the manufacturer under document revision level control and shall be made available to the preparing or acquiring activity upon request. The test circuit shall specify the inputs, outputs, biases, and power dissipation, as applicable, in accordance with the intent specified in test method 1005 of MIL-STD-883.
- b. $T_A = +125^\circ\text{C}$, minimum.
- c. Test duration: 1,000 hours, except as permitted by method 1005 of MIL-STD-883.

4.4.2.2 Additional criteria for device classes Q and V. The steady-state life test duration, test condition and test temperature, or approved alternatives shall be as specified in the device manufacturer's QM plan in accordance with MIL-PRF-38535. The test circuit shall be maintained under document revision level control by the device manufacturer's TRB in accordance with MIL-PRF-38535 and shall be made available to the acquiring or preparing activity upon request. The test circuit shall specify the inputs, outputs, biases, and power dissipation, as applicable, in accordance with the intent specified in test method 1005 of MIL-STD-883.

STANDARD MICROCIRCUIT DRAWING DEFENSE SUPPLY CENTER COLUMBUS COLUMBUS, OHIO 43216-5000	SIZE A		5962-00B02
		REVISION LEVEL D	SHEET 23

4.4.3 Group D inspection. The group D inspection end-point electrical parameters shall be as specified in table II herein.

4.4.4 Group E inspection. Group E inspection is required only for parts intended to be marked as radiation hardness assured (see 3.5 herein).

- a. End-point electrical parameters shall be as specified in table II herein.
- b. For device classes Q and V, the devices or test vehicle shall be subjected to radiation hardness assured tests as specified in MIL-PRF-38535 for the RHA level being tested. For device class M, the devices shall be subjected to radiation hardness assured tests as specified in MIL-PRF-38535, appendix A for the RHA level being tested. All device classes must meet the postirradiation end-point electrical parameter limits as defined in table I at $T_A = +25^{\circ}\text{C} \pm 5^{\circ}\text{C}$, after exposure, to the subgroups specified in table II herein.
- c. When specified in the purchase order or contract, a copy of the RHA delta limits shall be supplied.

5. PACKAGING

5.1 Packaging requirements. The requirements for packaging shall be in accordance with MIL-PRF-38535 for device classes Q and V or MIL-PRF-38535, appendix A for device class M.

6. NOTES

6.1 Intended use. Microcircuits conforming to this drawing are intended for use for Government microcircuit applications (original equipment), design applications, and logistics purposes.

6.1.1 Replaceability. Microcircuits covered by this drawing will replace the same generic device covered by a contractor prepared specification or drawing.

6.1.2 Substitutability. Device class Q devices will replace device class M devices.

6.2 Configuration control of SMD's. All proposed changes to existing SMD's will be coordinated with the users of record for the individual documents. This coordination will be accomplished using DD Form 1692, Engineering Change Proposal.

6.3 Record of users. Military and industrial users should inform Defense Supply Center Columbus when a system application requires configuration control and which SMD's are applicable to that system. DSCC will maintain a record of users and this list will be used for coordination and distribution of changes to the drawings. Users of drawings covering microelectronic devices (FSC 5962) should contact DSCC-VA, telephone (614) 692-0544.

6.4 Comments. Comments on this drawing should be directed to DSCC-VA, Columbus, Ohio 43216-5000, or telephone (614) 692-0547.

6.5 Abbreviations, symbols, and definitions. The abbreviations, symbols, and definitions used herein are defined in MIL-PRF-38535 and MIL-HDBK-1331.

6.6 Sources of supply.

6.6.1 Sources of supply for device classes Q and V. Sources of supply for device classes Q and V are listed in QML-38535. The vendors listed in QML-38535 have submitted a certificate of compliance (see 3.6 herein) to DSCC-VA and have agreed to this drawing.

6.6.2 Approved sources of supply for device class M. Approved sources of supply for class M are listed in MIL-HDBK-103. The vendors listed in MIL-HDBK-103 have agreed to this drawing and a certificate of compliance (see 3.6 herein) has been submitted to and accepted by DSCC-VA.

STANDARD MICROCIRCUIT DRAWING DEFENSE SUPPLY CENTER COLUMBUS COLUMBUS, OHIO 43216-5000	SIZE A		5962-00B02
		REVISION LEVEL D	SHEET 24

10. SCOPE

10.1 Scope. This appendix establishes minimum requirements for microcircuit die to be supplied under the Qualified Manufacturers List (QML) Program. QML microcircuit die meeting the requirements of MIL-PRF-38535 and the manufacturers approved QML plan for use in monolithic microcircuits, multichip modules (MCMs), hybrids, electronic modules, or devices using chip and wire designs in accordance with MIL-PRF-38534 are specified herein. Two product assurance classes consisting of military high reliability (device class Q) and space application (device Class V) are reflected in the Part or Identification Number (PIN). When available a choice of Radiation Hardiness Assurance (RHA) levels are reflected in the PIN.

10.2 PIN. The PIN is as shown in the following example:

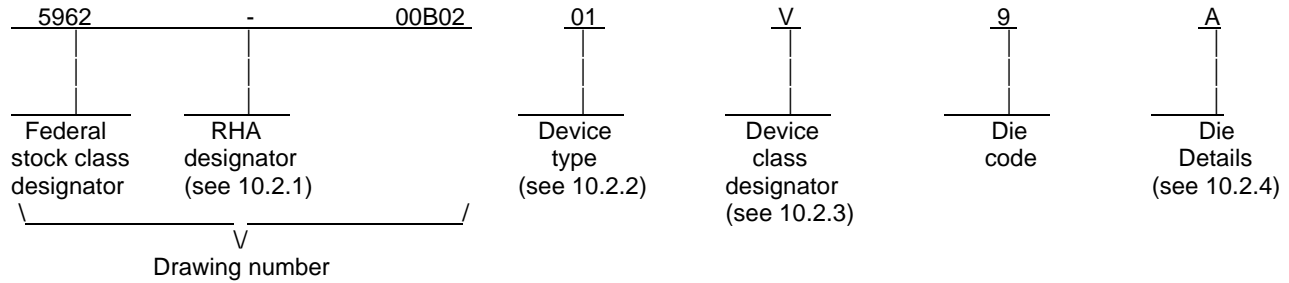

10.2.1 RHA designator. Device classes Q and V RHA identified die shall meet the MIL-PRF-38535 specified RHA levels. A dash (-) indicates a non-RHA die.

10.2.2 Device type(s). The device type(s) shall identify the circuit function as follows:

Device type	Generic number	Circuit function
01	MG2044E	44,000 MG2RT gates available
02	MG2091E	91,000 MG2RT gates available
03	MG2140E	140,000 MG2RT gates available
04	MG2194E	194,000 MG2RT gates available
05	MG2265E	265,000 MG2RT gates available
06	MG2360E	360,000 MG2RT gates available
07	MG2480E	480,000 MG2RT gates available
09	MG2044	44,000 MG2 gates available
10	MG2091	91,000 MG2 gates available
11	MG2140	140,000 MG2 gates available
12	MG2194	194,000 MG2 gates available
13	MG2265	265,000 MG2 gates available
14	MG2360	360,000 MG2 gates available
15	MG2480	480,000 MG2 gates available
16	MG2M044E	composite 44,000 MG2RT gates available
17	MG2M091E	composite 91,000 MG2RT gates available
18	MG2M140E	composite 140,000 MG2RT gates available
19	MG2M194E	composite 194,000 MG2RT gates available
20	MG2M265E	composite 265,000 MG2RT gates available
21	MG2M360E	composite 360,000 MG2RT gates available
22	MG2M480E	composite 480,000 MG2RT gates available
23	MG2M044	composite 44,000 MG2 gates available
24	MG2M091	composite 91,000 MG2 gates available
25	MG2M140	composite 140,000 MG2 gates available
26	MG2M194	composite 194,000 MG2 gates available
27	MG2M265	composite 265,000 MG2 gates available
28	MG2M360	composite 360,000 MG2 gates available
29	MG2M480	composite 480,000 MG2 gates available

STANDARD MICROCIRCUIT DRAWING DEFENSE SUPPLY CENTER COLUMBUS COLUMBUS, OHIO 43216-5000	SIZE A		5962-00B02
		REVISION LEVEL E	SHEET 25

10.2.3 Device class designator.

Device class	Device requirements documentation
Q or V	Certification and qualification to the die requirements of MIL-PRF-38535

10.2.4 Die Details. The die details designation shall be a unique letter which designates the die physical dimensions, bonding pad location(s) and related electrical function(s), interface materials, and other assembly related information, for each product and variant supplied to this appendix.

10.2.4.1 Die physical dimensions.

Die type	Figure number
01	A-1
02	A-2
03	A-3
04	A-4
05	A-5
06	A-6
07	A-7
08	REVERSED
09	A-1
10	A-2
11	A-3
12	A-4
13	A-5
14	A-6
15	A-7
16	A-1
17	A-2
18	A-3
19	A-4
20	A-5
21	A-6
22	A-7
23	A-1
24	A-2
25	A-3
26	A-4
27	A-5
28	A-6
29	A-7

STANDARD MICROCIRCUIT DRAWING DEFENSE SUPPLY CENTER COLUMBUS COLUMBUS, OHIO 43216-5000	SIZE A		5962-00B02
		REVISION LEVEL E	SHEET 26

10.2.4.2 Die bonding pad locations and electrical functions.

Die type	Figure number
01	A-1
02	A-2
03	A-3
04	A-4
05	A-5
06	A-6
07	A-7
08	RESERVED
09	A-1
10	A-2
11	A-3
12	A-4
13	A-5
14	A-6
15	A-7
16	A-1
17	A-2
18	A-3
19	A-4
20	A-5
21	A-6
22	A-7
23	A-1
24	A-2
25	A-3
26	A-4
27	A-5
28	A-6
29	A-7

STANDARD MICROCIRCUIT DRAWING DEFENSE SUPPLY CENTER COLUMBUS COLUMBUS, OHIO 43216-5000	SIZE A		5962-00B02
		REVISION LEVEL E	SHEET 27

10.2.4.3 Interface materials.

Die type	Figure number
01	A-1
02	A-2
03	A-3
04	A-4
05	A-5
06	A-6
07	A-7
08	RESERVED
09	A-1
10	A-2
11	A-3
12	A-4
13	A-5
14	A-6
15	A-7
16	A-1
17	A-2
18	A-3
19	A-4
20	A-5
21	A-6
22	A-7
23	A-1
24	A-2
25	A-3
26	A-4
27	A-5
28	A-6
29	A-7

STANDARD MICROCIRCUIT DRAWING DEFENSE SUPPLY CENTER COLUMBUS COLUMBUS, OHIO 43216-5000	SIZE A		5962-00B02
		REVISION LEVEL E	SHEET 28

10.2.4.4 Assembly related information.

Die type	Figure number
01	A-1
02	A-2
03	A-3
04	A-4
05	A-5
06	A-6
07	A-7
08	RESERVED
09	A-1
10	A-2
11	A-3
12	A-4
13	A-5
14	A-6
15	A-7
16	A-1
17	A-2
18	A-3
19	A-4
20	A-5
21	A-6
22	A-7
23	A-1
24	A-2
25	A-3
26	A-4
27	A-5
28	A-6
29	A-7

10.3 Absolute maximum ratings. See paragraph 1.3 within the body of this drawing for details.

10.4 Recommended operating conditions. See paragraph 1.4 within the body of this drawing for details.

STANDARD MICROCIRCUIT DRAWING DEFENSE SUPPLY CENTER COLUMBUS COLUMBUS, OHIO 43216-5000	SIZE A		5962-00B02
		REVISION LEVEL E	SHEET 29

20. APPLICABLE DOCUMENTS.

20.1 Government specifications, standards, and handbooks. Unless otherwise specified, the following specification, standard, and handbook of the issue listed in that issue of the Department of Defense Index of Specifications and Standards specified in the solicitation, form a part of this drawing to the extent specified herein.

SPECIFICATION

DEPARTMENT OF DEFENSE

MIL-PRF-38535 - Integrated Circuits, Manufacturing, General Specification for.

STANDARDS

DEPARTMENT OF DEFENSE

MIL-STD-883 - Test Method Standard Microcircuits.

HANDBOOK

DEPARTMENT OF DEFENSE

MIL-HDBK-103 - List of Standard Microcircuit Drawings (SMD's).

(Copies of the specification, standard, and handbook required by manufacturers in connection with specific acquisition functions should be obtained from the contracting activity or as directed by the contracting activity).

20.2. Order of precedence. In the event of a conflict between the text of this drawing and the references cited herein, the text of this drawing shall take precedence.

30. REQUIREMENTS

30.1 Item requirements. The individual item requirements for device classes Q and V shall be in accordance with MIL-PRF-38535 and as specified herein or as modified in the device manufacturer's Quality Management (QM) plan. The modification in the QM plan shall not effect the form, fit or function as described herein.

30.2 Design, construction and physical dimensions. The design, construction and physical dimensions shall be as specified in MIL-PRF-38535 and the manufacturer's QM plan, for device classes Q and V and herein.

30.2.1 Die physical dimensions. The die physical dimensions shall be as specified in 10.2.4.1 and on figures A-1 thru A-7.

30.2.2 Die bonding pad locations and electrical functions. The die bonding pad locations and electrical functions shall be as specified in 10.2.4.2 and on figures A-1 thru A-7.

30.2.3 Interface materials. The interface materials for the die shall be as specified in 10.2.4.3 and on figures A-1 thru A-7.

30.2.4 Assembly related information. The assembly related information shall be as specified in 10.2.4.4 and figures A-1 thru A-7.

30.2.5 Truth table(s). The truth table(s) shall be as defined within paragraph 3.2.3. of the body of this document.

30.3 Electrical performance characteristics and post-irradiation parameter limits. Unless otherwise specified herein, the electrical performance characteristics and post-irradiation parameter limits are as specified in table I of the body of this document.

30.4 Electrical test requirements. The wafer probe test requirements shall include functional and parametric testing sufficient to make the packaged die capable of meeting the electrical performance requirements in table I.

STANDARD MICROCIRCUIT DRAWING DEFENSE SUPPLY CENTER COLUMBUS COLUMBUS, OHIO 43216-5000	SIZE A		5962-00B02
		REVISION LEVEL E	SHEET 30

30.5 Marking. As a minimum, each unique lot of die, loaded in single or multiple stack of carriers, for shipment to a customer, shall be identified with the wafer lot number, the certification mark, the manufacturer's identification and the PIN listed in 10.2 herein. The certification mark shall be a "QML" or 'Q' as required by MIL-PRF-38535.

30.6 Certification of compliance. For device classes Q and V, a certificate of compliance shall be required from a QML-38535 listed manufacturer in order to supply to the requirements of this drawing (see 60.4 herein). The certificate of compliance submitted to DSCC-VA prior to listing as an approved source of supply for this appendix shall affirm that the manufacturer's product meets, for device classes Q and V, the requirements of MIL-PRF-38535 and the requirements herein.

30.7 Certificate of conformance. A certificate of conformance as required for device classes Q and V in MIL-PRF-38535 shall be provided with each lot of microcircuit die delivered to this drawing.

40. QUALITY ASSURANCE PROVISIONS

40.1 Sampling and inspection. For device classes Q and V, die sampling and inspection procedures shall be in accordance with MIL-PRF-38535 or as modified in the device manufacturer's Quality Management (QM) plan. The modifications in the QM plan shall not effect the form, fit or function as described herein.

40.2 Screening. For device classes Q and V, screening shall be in accordance with MIL-PRF-38535, and as defined in the manufacturer's QM plan. As a minimum it shall consist of:

- a) Wafer lot acceptance for Class V product using the criteria defined within MIL-STD-883 test method 5007.
- b) 100% wafer probe (see paragraph 30.4).

c) 100% internal visual inspection to the applicable class Q or V criteria defined within MIL-STD-883 test method 2010 or the alternate procedures allowed within MIL-STD-883 test method 5004.

40.3 Conformance inspection.

40.3.1 Group E inspection. Group E inspection is required only for parts intended to be identified as radiation assured (see 30.5 herein). RHA levels for device classes Q and V shall be as specified in MIL-PRF-38535. End point electrical testing of packaged die shall be as specified in table IIA herein. Group E tests and conditions are as specified within paragraphs 4.4.4.1, 4.4.4.1.1., 4.4.4.2, 4.4.4.3 and 4.4.4.4.

50. DIE CARRIER

50.1 Die carrier requirements. The requirements for the die carrier shall be accordance with the manufacturer's QM plan or as specified in the purchase order by the acquiring activity. The die carrier shall provide adequate physical, mechanical and electrostatic protection.

60 NOTES

60.1 Intended use. Microcircuit die conforming to this drawing are intended for use in microcircuits built in accordance with MIL-PRF-38535 or MIL-PRF-38534 for government microcircuit applications (original equipment), design applications and logistics purposes.

60.2 Comments. Comments on this appendix should be directed to DSCC-VA, Columbus, Ohio, 43216-5000 or telephone (614)-692-0547.

60.3 Abbreviations, symbols and definitions. The abbreviations, symbols, and definitions used herein are defined within MIL-PRF-38535 and MIL-STD-1331.

60.4 Sources of supply for device classes Q and V. Sources of supply for device classes Q and V are listed in QML-38535. The vendors listed within QML-38535 have submitted a certificate of compliance (see 30.6 herein) to DSCC-VA and have agreed to this drawing.

STANDARD MICROCIRCUIT DRAWING DEFENSE SUPPLY CENTER COLUMBUS COLUMBUS, OHIO 43216-5000	SIZE A		5962-00B02
		REVISION LEVEL E	SHEET 31

Due to the complexity of the device, a graphical representation of the pad locations is not available. This figure shall be maintained and available from the device manufacturer.

See subsequent pages for a table of pad locations.

Die bonding pad locations and electrical functions

Die physical dimensions.

Die size: 4940.04 x 4840.11 microns (with scribe line)

Die thickness: 475 microns

Interface materials.

Top metallization: Aluminium + Copper

Backside metallization: Bare Silicon

Glassivation.

Type: Oxinitride

Thickness: 10,000 Angstroms

Substrate: Single crystal silicon

Assembly related information.

Substrate potential: Not connected

Special assembly instructions: None

FIGURE A-1. Die bonding pad locations and electrical functions.

STANDARD MICROCIRCUIT DRAWING DEFENSE SUPPLY CENTER COLUMBUS COLUMBUS, OHIO 43216-5000	SIZE A		5962-00B02
		REVISION LEVEL E	SHEET 32

Pads Location

pad	X	Y	type
1	19.624	22.252	POWER
2	18.678	22.252	POWER
3	17.732	22.252	
4	16.786	22.252	
5	15.840	22.252	
6	14.894	22.252	
7	13.948	22.252	
8	13.002	22.252	
9	12.056	22.252	
10	11.110	22.252	
11	10.164	22.252	
12	9.218	22.252	
13	8.272	22.252	
14	7.326	22.252	
15	6.380	22.252	
16	5.434	22.252	
17	4.488	22.252	
18	3.542	22.252	
19	2.596	22.252	
20	1.650	22.252	
21	0.704	22.252	
22	-0.242	22.252	
23	-1.188	22.252	
24	-2.134	22.252	
25	-3.080	22.252	
26	-4.026	22.252	
27	-4.972	22.252	
28	-5.918	22.252	
29	-6.864	22.252	
30	-7.810	22.252	
31	-8.756	22.252	
32	-9.702	22.252	
33	-10.648	22.252	
34	-11.594	22.252	
35	-12.540	22.252	
36	-13.486	22.252	
37	-14.432	22.252	

FIGURE A-1. Die bonding pad locations and electrical functions. – Continued

STANDARD MICROCIRCUIT DRAWING DEFENSE SUPPLY CENTER COLUMBUS COLUMBUS, OHIO 43216-5000	SIZE A		5962-00B02
		REVISION LEVEL E	SHEET 33

Pads Location

pad	X	Y	type
38	-15.378	22.252	
39	-16.324	22.252	
40	-17.270	22.252	
41	-18.385	22.252	BLOCK
42	-19.331	22.252	BLOCK
43	-22.722	20.767	BLOCK_NOPO
44	-22.722	19.821	BLOCK
45	-22.722	18.875	BLOCK
46	-22.722	17.263	
47	-22.722	16.317	
48	-22.722	15.371	
49	-22.722	14.425	
50	-22.722	13.479	
51	-22.722	12.533	
52	-22.722	11.587	
53	-22.722	10.641	
54	-22.722	9.695	
55	-22.722	8.749	
56	-22.722	7.803	
57	-22.722	6.857	
58	-22.722	5.911	
59	-22.722	4.965	
60	-22.722	4.019	
61	-22.722	3.073	
62	-22.722	2.127	
63	-22.722	1.181	
64	-22.722	0.235	
65	-22.722	-0.711	
66	-22.722	-1.657	
67	-22.722	-2.603	
68	-22.722	-3.549	
69	-22.722	-4.495	
70	-22.722	-5.441	
71	-22.722	-6.387	
72	-22.722	-7.333	
73	-22.722	-8.279	
74	-22.722	-9.225	
75	-22.722	-10.171	
76	-22.722	-11.117	
77	-22.722	-12.063	

FIGURE A-1. Die bonding pad locations and electrical functions. – Continued

STANDARD MICROCIRCUIT DRAWING DEFENSE SUPPLY CENTER COLUMBUS COLUMBUS, OHIO 43216-5000	SIZE A		5962-00B02
		REVISION LEVEL E	SHEET 34

Pads Location

pad	X	Y	type
78	-22.722	-13.009	
79	-22.722	-13.955	
80	-22.722	-14.901	
81	-22.722	-15.847	
82	-22.722	-16.793	
83	-22.722	-17.739	POWER
84	-22.722	-18.685	POWER
85	-22.722	-19.631	POWER
86	-22.462	-22.252	POWER
87	-21.516	-22.252	POWER
88	-20.570	-22.252	POWER
89	-19.624	-22.252	POWER
90	-18.678	-22.252	POWER
91	-17.732	-22.252	
92	-16.786	-22.252	
93	-15.840	-22.252	
94	-14.894	-22.252	
95	-13.948	-22.252	
96	-13.002	-22.252	
97	-12.056	-22.252	
98	-11.110	-22.252	
99	-10.164	-22.252	
100	-9.218	-22.252	
101	-8.272	-22.252	
102	-7.326	-22.252	
103	-6.380	-22.252	
104	-5.434	-22.252	
105	-4.488	-22.252	
106	-3.542	-22.252	
107	-2.596	-22.252	
108	-1.650	-22.252	
109	-0.704	-22.252	
110	0.242	-22.252	
111	1.188	-22.252	
112	2.134	-22.252	
113	3.080	-22.252	
114	4.026	-22.252	
115	4.972	-22.252	
116	5.918	-22.252	
117	6.864	-22.252	

FIGURE A-1. Die bonding pad locations and electrical functions. - Continued

STANDARD MICROCIRCUIT DRAWING DEFENSE SUPPLY CENTER COLUMBUS COLUMBUS, OHIO 43216-5000	SIZE A		5962-00B02
		REVISION LEVEL E	SHEET 35

Pads Location

pad	X	Y	type
118	7.810	-22.252	
119	8.756	-22.252	
120	9.702	-22.252	
121	10.648	-22.252	
122	11.594	-22.252	
123	12.540	-22.252	
124	13.486	-22.252	
125	14.432	-22.252	
126	15.378	-22.252	
127	16.324	-22.252	
128	17.270	-22.252	
129	18.385	-22.252	BLOCK
130	19.331	-22.252	BLOCK
131	22.722	-20.767	BLOCK_NOPO
132	22.722	-19.821	BLOCK
133	22.722	-18.875	BLOCK
134	22.722	-17.263	
135	22.722	-16.317	
136	22.722	-15.371	
137	22.722	-14.425	
138	22.722	-13.479	
139	22.722	-12.533	
140	22.722	-11.587	
141	22.722	-10.641	
142	22.722	-9.695	
143	22.722	-8.749	
144	22.722	-7.803	
145	22.722	-6.857	
146	22.722	-5.911	
147	22.722	-4.965	
148	22.722	-4.019	
149	22.722	-3.073	
150	22.722	-2.127	
151	22.722	-1.181	
152	22.722	-0.235	
153	22.722	0.711	
154	22.722	1.657	
155	22.722	2.603	
156	22.722	3.549	
157	22.722	4.495	

FIGURE A-1. Die bonding pad locations and electrical functions. - Continued

STANDARD MICROCIRCUIT DRAWING DEFENSE SUPPLY CENTER COLUMBUS COLUMBUS, OHIO 43216-5000	SIZE A		5962-00B02
		REVISION LEVEL E	SHEET 36

Pads Location

pad	X	Y	type
158	22.722	5.441	
159	22.722	6.387	
160	22.722	7.333	
161	22.722	8.279	
162	22.722	9.225	
163	22.722	10.171	
164	22.722	11.117	
165	22.722	12.063	
166	22.722	13.009	
167	22.722	13.955	
168	22.722	14.901	
169	22.722	15.847	
170	22.722	16.793	
171	22.722	19.053	BLOCK
172	22.722	19.999	BLOCK
173	22.722	21.007	POWER

FIGURE A-1. Die bonding pad locations and electrical functions. - Continued

STANDARD MICROCIRCUIT DRAWING DEFENSE SUPPLY CENTER COLUMBUS COLUMBUS, OHIO 43216-5000	SIZE A		5962-00B02
		REVISION LEVEL E	SHEET 37

Due to the complexity of the device, a graphical representation of the pad locations is not available. This figure shall be maintained and available from the device manufacturer.

See subsequent pages for a table of pad locations.

Die bonding pad locations and electrical functions

Die physical dimensions.

Die size: 6600.05 x 6530.05 microns (with scribe line)

Die thickness: 475 microns

Interface materials.

Top metallization: Aluminium + Copper

Backside metallization: Bare Silicon

Glassivation.

Type: Oxinitride

Thickness: 10,000 Angstroms

Substrate: Single crystal silicon

Assembly related information.

Substrate potential: Not connected

Special assembly instructions: None

FIGURE A-2. Die bonding pad locations and electrical functions.

STANDARD MICROCIRCUIT DRAWING DEFENSE SUPPLY CENTER COLUMBUS COLUMBUS, OHIO 43216-5000	SIZE A		5962-00B02
		REVISION LEVEL E	SHEET 38

Pads Location

pad	X	Y	type
1	27.132	29.858	POWER
2	26.186	29.858	POWER
3	25.240	29.858	
4	24.294	29.858	
5	23.348	29.858	
6	22.402	29.858	
7	21.456	29.858	
8	20.510	29.858	
9	19.564	29.858	
10	18.618	29.858	
11	17.672	29.858	
12	16.726	29.858	
13	15.780	29.858	
14	14.834	29.858	
15	13.888	29.858	
16	12.942	29.858	
17	11.996	29.858	
18	11.050	29.858	
19	10.104	29.858	
20	9.158	29.858	
21	8.212	29.858	
22	7.266	29.858	
23	6.320	29.858	
24	5.374	29.858	
25	4.428	29.858	
26	3.482	29.858	
27	2.536	29.858	
28	1.590	29.858	
29	0.644	29.858	
30	-0.302	29.858	
31	-1.248	29.858	
32	-2.194	29.858	
33	-3.140	29.858	
34	-4.086	29.858	
35	-5.032	29.858	
36	-5.978	29.858	
37	-6.924	29.858	

FIGURE A-2. Die bonding pad locations and electrical functions. – Continued

STANDARD MICROCIRCUIT DRAWING DEFENSE SUPPLY CENTER COLUMBUS COLUMBUS, OHIO 43216-5000	SIZE A		5962-00B02
		REVISION LEVEL E	SHEET 39

Pads Location

pad	X	Y	type
38	-7.870	29.858	
39	-8.816	29.858	
40	-9.762	29.858	
41	-10.708	29.858	
42	-11.654	29.858	
43	-12.600	29.858	
44	-13.546	29.858	
45	-14.492	29.858	
46	-15.438	29.858	
47	-16.384	29.858	
48	-17.330	29.858	
49	-18.276	29.858	
50	-19.222	29.858	
51	-20.168	29.858	
52	-21.114	29.858	
53	-22.060	29.858	
54	-23.006	29.858	
55	-23.952	29.858	
56	-24.898	29.858	
57	-25.892	29.858	BLOCK
58	-26.838	29.858	BLOCK
59	-30.229	28.373	BLOCK_NOPO
60	-30.229	27.427	BLOCK
61	-30.229	26.481	BLOCK
62	-30.229	24.869	
63	-30.229	23.923	
64	-30.229	22.977	
65	-30.229	22.031	
66	-30.229	21.085	
67	-30.229	20.139	
68	-30.229	19.193	
69	-30.229	18.247	
70	-30.229	17.301	
71	-30.229	16.355	
72	-30.229	15.409	
73	-30.229	14.463	
74	-30.229	13.517	
75	-30.229	12.571	
76	-30.229	11.625	
77	-30.229	10.679	

FIGURE A-2. Die bonding pad locations and electrical functions. – Continued

STANDARD MICROCIRCUIT DRAWING DEFENSE SUPPLY CENTER COLUMBUS COLUMBUS, OHIO 43216-5000	SIZE A		5962-00B02
		REVISION LEVEL E	SHEET 40

Pads Location

pad	X	Y	type
78	-30.229	9.733	
79	-30.229	8.787	
80	-30.229	7.841	
81	-30.229	6.895	
82	-30.229	5.949	
83	-30.229	5.003	
84	-30.229	4.057	
85	-30.229	3.111	
86	-30.229	2.165	
87	-30.229	1.219	
88	-30.229	0.273	
89	-30.229	-0.673	
90	-30.229	-1.619	
91	-30.229	-2.565	
92	-30.229	-3.511	
93	-30.229	-4.457	
94	-30.229	-5.403	
95	-30.229	-6.349	
96	-30.229	-7.295	
97	-30.229	-8.241	
98	-30.229	-9.187	
99	-30.229	-10.133	
100	-30.229	-11.079	
101	-30.229	-12.025	
102	-30.229	-12.971	
103	-30.229	-13.917	
104	-30.229	-14.863	
105	-30.229	-15.809	
106	-30.229	-16.755	
107	-30.229	-17.701	
108	-30.229	-18.647	
109	-30.229	-19.593	
110	-30.229	-20.539	
111	-30.229	-21.485	
112	-30.229	-22.431	
113	-30.229	-23.377	
114	-30.229	-24.323	
115	-30.229	-25.269	POWER
116	-30.229	-26.215	POWER
117	-30.229	-27.161	POWER

FIGURE A-2. Die bonding pad locations and electrical functions. - Continued

STANDARD MICROCIRCUIT DRAWING DEFENSE SUPPLY CENTER COLUMBUS COLUMBUS, OHIO 43216-5000	SIZE A		5962-00B02
		REVISION LEVEL E	SHEET 41

Pads Location

pad	X	Y	type
118	-29.970	-29.858	POWER
119	-29.024	-29.858	POWER
120	-28.078	-29.858	POWER
121	-27.132	-29.858	POWER
122	-26.186	-29.858	POWER
123	-25.240	-29.858	
124	-24.294	-29.858	
125	-23.348	-29.858	
126	-22.402	-29.858	
127	-21.456	-29.858	
128	-20.510	-29.858	
129	-19.564	-29.858	
130	-18.618	-29.858	
131	-17.672	-29.858	
132	-16.726	-29.858	
133	-15.780	-29.858	
134	-14.834	-29.858	
135	-13.888	-29.858	
136	-12.942	-29.858	
137	-11.996	-29.858	
138	-11.050	-29.858	
139	-10.104	-29.858	
140	-9.158	-29.858	
141	-8.212	-29.858	
142	-7.266	-29.858	
143	-6.320	-29.858	
144	-5.374	-29.858	
145	-4.428	-29.858	
146	-3.482	-29.858	
147	-2.536	-29.858	
148	-1.590	-29.858	
149	-0.644	-29.858	
150	0.302	-29.858	
151	1.248	-29.858	
152	2.194	-29.858	
153	3.140	-29.858	
154	4.086	-29.858	
155	5.032	-29.858	
156	5.978	-29.858	
157	6.924	-29.858	

FIGURE A-2. Die bonding pad locations and electrical functions. - Continued

STANDARD MICROCIRCUIT DRAWING DEFENSE SUPPLY CENTER COLUMBUS COLUMBUS, OHIO 43216-5000	SIZE A		5962-00B02
		REVISION LEVEL E	SHEET 42

Pads Location

pad	X	Y	type
158	7.870	-29.858	
159	8.816	-29.858	
160	9.762	-29.858	
161	10.708	-29.858	
162	11.654	-29.858	
163	12.600	-29.858	
164	13.546	-29.858	
165	14.492	-29.858	
166	15.438	-29.858	
167	16.384	-29.858	
168	17.330	-29.858	
169	18.276	-29.858	
170	19.222	-29.858	
171	20.168	-29.858	
172	21.114	-29.858	
173	22.060	-29.858	
174	23.006	-29.858	
175	23.952	-29.858	
176	24.898	-29.858	
177	25.892	-29.858	BLOCK
178	26.838	-29.858	BLOCK
179	30.229	-28.373	BLOCK_NOPO
180	30.229	-27.427	BLOCK
181	30.229	-26.481	BLOCK
182	30.229	-24.869	
183	30.229	-23.923	
184	30.229	-22.977	
185	30.229	-22.031	
186	30.229	-21.085	
187	30.229	-20.139	
188	30.229	-19.193	
189	30.229	-18.247	
190	30.229	-17.301	
191	30.229	-16.355	
192	30.229	-15.409	
193	30.229	-14.463	
194	30.229	-13.517	
195	30.229	-12.571	
196	30.229	-11.625	
197	30.229	-10.679	

FIGURE A-2. Die bonding pad locations and electrical functions. - Continued

STANDARD MICROCIRCUIT DRAWING DEFENSE SUPPLY CENTER COLUMBUS COLUMBUS, OHIO 43216-5000	SIZE A		5962-00B02
		REVISION LEVEL E	SHEET 43

Pads Location

pad	X	Y	type
198	30.229	-9.733	
199	30.229	-8.787	
200	30.229	-7.841	
201	30.229	-6.895	
202	30.229	-5.949	
203	30.229	-5.003	
204	30.229	-4.057	
205	30.229	-3.111	
206	30.229	-2.165	
207	30.229	-1.219	
208	30.229	-0.273	
209	30.229	0.673	
210	30.229	1.619	
211	30.229	2.565	
212	30.229	3.511	
213	30.229	4.457	
214	30.229	5.403	
215	30.229	6.349	
216	30.229	7.295	
217	30.229	8.241	
218	30.229	9.187	
219	30.229	10.133	
220	30.229	11.079	
221	30.229	12.025	
222	30.229	12.971	
223	30.229	13.917	
224	30.229	14.863	
225	30.229	15.809	
226	30.229	16.755	
227	30.229	17.701	
228	30.229	18.647	
229	30.229	19.593	
230	30.229	20.539	
231	30.229	21.485	
232	30.229	22.431	
233	30.229	23.377	
234	30.229	24.323	
235	30.229	26.659	BLOCK
236	30.229	27.605	BLOCK
237	30.229	28.613	POWER

FIGURE A-2. Die bonding pad locations and electrical functions. - Continued

STANDARD MICROCIRCUIT DRAWING DEFENSE SUPPLY CENTER COLUMBUS COLUMBUS, OHIO 43216-5000	SIZE A		5962-00B02
		REVISION LEVEL E	SHEET 44

Due to the complexity of the device, a graphical representation of the pad locations is not available. This figure shall be maintained and available from the device manufacturer.

See subsequent pages for a table of pad locations.

Die bonding pad locations and electrical functions

Die physical dimensions.

Die size: 7600.11 x 7590.13 microns (with scribe line)

Die thickness: 475 microns

Interface materials.

Top metallization: Aluminium + Copper

Backside metallization: Bare Silicon

Glassivation.

Type: Oxinitride

Thickness: 10,000 Angstroms

Substrate: Single crystal silicon

Assembly related information.

Substrate potential: Not connected

Special assembly instructions: None

FIGURE A-3. Die bonding pad locations and electrical functions.

STANDARD MICROCIRCUIT DRAWING DEFENSE SUPPLY CENTER COLUMBUS COLUMBUS, OHIO 43216-5000	SIZE A		5962-00B02
		REVISION LEVEL E	SHEET 45

Pads Location

pad	X	Y	type
1	32.920	35.997	POWER
2	31.974	35.997	POWER
3	31.028	35.997	
4	30.082	35.997	
5	29.136	35.997	
6	28.190	35.997	
7	27.244	35.997	
8	26.298	35.997	
9	25.352	35.997	
10	24.406	35.997	
11	23.460	35.997	
12	22.514	35.997	
13	21.568	35.997	
14	20.622	35.997	
15	19.676	35.997	
16	18.730	35.997	
17	17.784	35.997	
18	16.838	35.997	
19	15.892	35.997	
20	14.946	35.997	
21	14.000	35.997	
22	13.054	35.997	
23	12.108	35.997	
24	11.162	35.997	
25	10.216	35.997	
26	9.270	35.997	
27	8.324	35.997	
28	7.378	35.997	
29	6.432	35.997	
30	5.486	35.997	
31	4.540	35.997	
32	3.594	35.997	
33	2.648	35.997	
34	1.702	35.997	
35	0.756	35.997	
36	-0.190	35.997	
37	-1.136	35.997	

FIGURE A-3. Die bonding pad locations and electrical functions. - Continued

STANDARD MICROCIRCUIT DRAWING DEFENSE SUPPLY CENTER COLUMBUS COLUMBUS, OHIO 43216-5000	SIZE A		5962-00B02
		REVISION LEVEL E	SHEET 46

Pads Location

pad	X	Y	type
38	-2.082	35.997	
39	-3.028	35.997	
40	-3.974	35.997	
41	-4.920	35.997	
42	-5.866	35.997	
43	-6.812	35.997	
44	-7.758	35.997	
45	-8.704	35.997	
46	-9.650	35.997	
47	-10.596	35.997	
48	-11.542	35.997	
49	-12.488	35.997	
50	-13.434	35.997	
51	-14.380	35.997	
52	-15.326	35.997	
53	-16.272	35.997	
54	-17.218	35.997	
55	-18.164	35.997	
56	-19.110	35.997	
57	-20.056	35.997	
58	-21.002	35.997	
59	-21.948	35.997	
60	-22.894	35.997	
61	-23.840	35.997	
62	-24.786	35.997	
63	-25.732	35.997	
64	-26.678	35.997	
65	-27.624	35.997	
66	-28.570	35.997	
67	-29.516	35.997	
68	-30.462	35.997	
69	-31.680	35.997	BLOCK
70	-32.626	35.997	BLOCK
71	-36.017	34.511	BLOCK_NOPO
72	-36.017	33.565	BLOCK
73	-36.017	32.619	BLOCK
74	-36.017	31.007	
75	-36.017	30.061	
76	-36.017	29.115	
77	-36.017	28.169	

FIGURE A-3. Die bonding pad locations and electrical functions. - Continued

STANDARD MICROCIRCUIT DRAWING DEFENSE SUPPLY CENTER COLUMBUS COLUMBUS, OHIO 43216-5000	SIZE A		5962-00B02
		REVISION LEVEL E	SHEET 47

Pads Location

pad	X	Y	type
78	-36.017	27.223	
79	-36.017	26.277	
80	-36.017	25.331	
81	-36.017	24.385	
82	-36.017	23.439	
83	-36.017	22.493	
84	-36.017	21.547	
85	-36.017	20.601	
86	-36.017	19.655	
87	-36.017	18.709	
88	-36.017	17.763	
89	-36.017	16.817	
90	-36.017	15.871	
91	-36.017	14.925	
92	-36.017	13.979	
93	-36.017	13.033	
94	-36.017	12.087	
95	-36.017	11.141	
96	-36.017	10.195	
97	-36.017	9.249	
98	-36.017	8.303	
99	-36.017	7.357	
100	-36.017	6.411	
101	-36.017	5.465	
102	-36.017	4.519	
103	-36.017	3.573	
104	-36.017	2.627	
105	-36.017	1.681	
106	-36.017	0.735	
107	-36.017	-0.211	
108	-36.017	-1.157	
109	-36.017	-2.103	
110	-36.017	-3.049	
111	-36.017	-3.995	
112	-36.017	-4.941	
113	-36.017	-5.887	
114	-36.017	-6.833	
115	-36.017	-7.779	
116	-36.017	-8.725	
117	-36.017	-9.671	

FIGURE A-3. Die bonding pad locations and electrical functions. - Continued

STANDARD MICROCIRCUIT DRAWING DEFENSE SUPPLY CENTER COLUMBUS COLUMBUS, OHIO 43216-5000	SIZE A		5962-00B02
		REVISION LEVEL E	SHEET 48

Pads Location

pad	X	Y	type
118	-36.017	-10.617	
119	-36.017	-11.563	
120	-36.017	-12.509	
121	-36.017	-13.455	
122	-36.017	-14.401	
123	-36.017	-15.347	
124	-36.017	-16.293	
125	-36.017	-17.239	
126	-36.017	-18.185	
127	-36.017	-19.131	
128	-36.017	-20.077	
129	-36.017	-21.023	
130	-36.017	-21.969	
131	-36.017	-22.915	
132	-36.017	-23.861	
133	-36.017	-24.807	
134	-36.017	-25.753	
135	-36.017	-26.699	
136	-36.017	-27.645	
137	-36.017	-28.591	
138	-36.017	-29.537	
139	-36.017	-30.483	
140	-36.017	-31.429	POWER
141	-36.017	-32.375	POWER
142	-36.017	-33.321	POWER
143	-35.758	-35.997	POWER
144	-34.812	-35.997	POWER
145	-33.866	-35.997	POWER
146	-32.920	-35.997	POWER
147	-31.974	-35.997	POWER
148	-31.028	-35.997	
149	-30.082	-35.997	
150	-29.136	-35.997	
151	-28.190	-35.997	
152	-27.244	-35.997	
153	-26.298	-35.997	
154	-25.352	-35.997	
155	-24.406	-35.997	
156	-23.460	-35.997	
157	-22.514	-35.997	

FIGURE A-3. Die bonding pad locations and electrical functions. - Continued

STANDARD MICROCIRCUIT DRAWING DEFENSE SUPPLY CENTER COLUMBUS COLUMBUS, OHIO 43216-5000	SIZE A		5962-00B02
		REVISION LEVEL E	SHEET 49

Pads Location

pad	X	Y	type
158	-21.568	-35.997	
159	-20.622	-35.997	
160	-19.676	-35.997	
161	-18.730	-35.997	
162	-17.784	-35.997	
163	-16.838	-35.997	
164	-15.892	-35.997	
165	-14.946	-35.997	
166	-14.000	-35.997	
167	-13.054	-35.997	
168	-12.108	-35.997	
169	-11.162	-35.997	
170	-10.216	-35.997	
171	-9.270	-35.997	
172	-8.324	-35.997	
173	-7.378	-35.997	
174	-6.432	-35.997	
175	-5.486	-35.997	
176	-4.540	-35.997	
177	-3.594	-35.997	
178	-2.648	-35.997	
179	-1.702	-35.997	
180	-0.756	-35.997	
181	0.190	-35.997	
182	1.136	-35.997	
183	2.082	-35.997	
184	3.028	-35.997	
185	3.974	-35.997	
186	4.920	-35.997	
187	5.866	-35.997	
188	6.812	-35.997	
189	7.758	-35.997	
190	8.704	-35.997	
191	9.650	-35.997	
192	10.596	-35.997	
193	11.542	-35.997	
194	12.488	-35.997	
195	13.434	-35.997	
196	14.380	-35.997	
197	15.326	-35.997	

FIGURE A-3. Die bonding pad locations and electrical functions. - Continued

STANDARD MICROCIRCUIT DRAWING DEFENSE SUPPLY CENTER COLUMBUS COLUMBUS, OHIO 43216-5000	SIZE A		5962-00B02
		REVISION LEVEL E	SHEET 50

Pads Location

pad	X	Y	type
198	16.272	-35.997	
199	17.218	-35.997	
200	18.164	-35.997	
201	19.110	-35.997	
202	20.056	-35.997	
203	21.002	-35.997	
204	21.948	-35.997	
205	22.894	-35.997	
206	23.840	-35.997	
207	24.786	-35.997	
208	25.732	-35.997	
209	26.678	-35.997	
210	27.624	-35.997	
211	28.570	-35.997	
212	29.516	-35.997	
213	30.462	-35.997	
214	31.680	-35.997	BLOCK
215	32.626	-35.997	BLOCK
216	36.017	-34.511	BLOCK_NOPO
217	36.017	-33.565	BLOCK
218	36.017	-32.619	BLOCK
219	36.017	-31.007	
220	36.017	-30.061	
221	36.017	-29.115	
222	36.017	-28.169	
223	36.017	-27.223	
224	36.017	-26.277	
225	36.017	-25.331	
226	36.017	-24.385	
227	36.017	-23.439	
228	36.017	-22.493	
229	36.017	-21.547	
230	36.017	-20.601	
231	36.017	-19.655	
232	36.017	-18.709	
233	36.017	-17.763	
234	36.017	-16.817	
235	36.017	-15.871	
236	36.017	-14.925	
237	36.017	-13.979	

FIGURE A-3. Die bonding pad locations and electrical functions. - Continued

STANDARD MICROCIRCUIT DRAWING DEFENSE SUPPLY CENTER COLUMBUS COLUMBUS, OHIO 43216-5000	SIZE A		5962-00B02
		REVISION LEVEL E	SHEET 51

Pads Location

pad	X	Y	type
238	36.017	-13.033	
239	36.017	-12.087	
240	36.017	-11.141	
241	36.017	-10.195	
242	36.017	-9.249	
243	36.017	-8.303	
244	36.017	-7.357	
245	36.017	-6.411	
246	36.017	-5.465	
247	36.017	-4.519	
248	36.017	-3.573	
249	36.017	-2.627	
250	36.017	-1.681	
251	36.017	-0.735	
252	36.017	0.211	
253	36.017	1.157	
254	36.017	2.103	
255	36.017	3.049	
256	36.017	3.995	
257	36.017	4.941	
258	36.017	5.887	
259	36.017	6.833	
260	36.017	7.779	
261	36.017	8.725	
262	36.017	9.671	
263	36.017	10.617	
264	36.017	11.563	
265	36.017	12.509	
266	36.017	13.455	
267	36.017	14.401	
268	36.017	15.347	
269	36.017	16.293	
270	36.017	17.239	
271	36.017	18.185	
272	36.017	19.131	
273	36.017	20.077	
274	36.017	21.023	
275	36.017	21.969	
276	36.017	22.915	
277	36.017	23.861	

FIGURE A-3. Die bonding pad locations and electrical functions. - Continued

STANDARD MICROCIRCUIT DRAWING DEFENSE SUPPLY CENTER COLUMBUS COLUMBUS, OHIO 43216-5000	SIZE A		5962-00B02
		REVISION LEVEL E	SHEET 52

Pads Location

pad	X	Y	type
278	36.017	24.807	
279	36.017	25.753	
280	36.017	26.699	
281	36.017	27.645	
282	36.017	28.591	
283	36.017	29.537	
284	36.017	30.483	
285	36.017	32.797	BLOCK
286	36.017	33.743	BLOCK
287	36.017	34.752	POWER

FIGURE A-3. Die bonding pad locations and electrical functions. - Continued

STANDARD MICROCIRCUIT DRAWING DEFENSE SUPPLY CENTER COLUMBUS COLUMBUS, OHIO 43216-5000	SIZE A		5962-00B02
		REVISION LEVEL E	SHEET 53

Due to the complexity of the device, a graphical representation of the pad locations is not available. This figure shall be maintained and available from the device manufacturer.

See subsequent pages for a table of pad locations.

Die bonding pad locations and electrical functions

Die physical dimensions.

Die size: 8730 x 8790 microns (with scribe line)

Die thickness: 475 microns

Interface materials.

Top metallization: Aluminium + Copper

Backside metallization: Bare Silicon

Glassivation.

Type: Oxinitride

Thickness: 10,000 Angstroms

Substrate: Single crystal silicon

Assembly related information.

Substrate potential: Not connected

Special assembly instructions: None

FIGURE A-4. Die bonding pad locations and electrical functions.

STANDARD MICROCIRCUIT DRAWING DEFENSE SUPPLY CENTER COLUMBUS COLUMBUS, OHIO 43216-5000	SIZE A		5962-00B02
		REVISION LEVEL E	SHEET 54

Pads Location

pad	X	Y	type
1	38.596	41.186	POWER
2	37.650	41.186	POWER
3	36.704	41.186	
4	35.758	41.186	
5	34.812	41.186	
6	33.866	41.186	
7	32.920	41.186	
8	31.974	41.186	
9	31.028	41.186	
10	30.082	41.186	
11	29.136	41.186	
12	28.190	41.186	
13	27.244	41.186	
14	26.298	41.186	
15	25.352	41.186	
16	24.406	41.186	
17	23.460	41.186	
18	22.514	41.186	
19	21.568	41.186	
20	20.622	41.186	
21	19.676	41.186	
22	18.730	41.186	
23	17.784	41.186	
24	16.838	41.186	
25	15.892	41.186	
26	14.946	41.186	
27	14.000	41.186	
28	13.054	41.186	
29	12.108	41.186	
30	11.162	41.186	
31	10.216	41.186	
32	9.270	41.186	
33	8.324	41.186	
34	7.378	41.186	
35	6.432	41.186	
36	5.486	41.186	
37	4.540	41.186	

FIGURE A-4. Die bonding pad locations and electrical functions. – Continued

STANDARD MICROCIRCUIT DRAWING DEFENSE SUPPLY CENTER COLUMBUS COLUMBUS, OHIO 43216-5000	SIZE A		5962-00B02
		REVISION LEVEL E	SHEET 55

Pads Location

pad	X	Y	type
38	3.594	41.186	
39	2.648	41.186	
40	1.702	41.186	
41	0.756	41.186	
42	-0.190	41.186	
43	-1.136	41.186	
44	-2.082	41.186	
45	-3.028	41.186	
46	-3.974	41.186	
47	-4.920	41.186	
48	-5.866	41.186	
49	-6.812	41.186	
50	-7.758	41.186	
51	-8.704	41.186	
52	-9.650	41.186	
53	-10.596	41.186	
54	-11.542	41.186	
55	-12.488	41.186	
56	-13.434	41.186	
57	-14.380	41.186	
58	-15.326	41.186	
59	-16.272	41.186	
60	-17.218	41.186	
61	-18.164	41.186	
62	-19.110	41.186	
63	-20.056	41.186	
64	-21.002	41.186	
65	-21.948	41.186	
66	-22.894	41.186	
67	-23.840	41.186	
68	-24.786	41.186	
69	-25.732	41.186	
70	-26.678	41.186	
71	-27.624	41.186	
72	-28.570	41.186	
73	-29.516	41.186	
74	-30.462	41.186	
75	-31.408	41.186	
76	-32.354	41.186	
77	-33.300	41.186	

FIGURE A-4. Die bonding pad locations and electrical functions. – Continued

STANDARD MICROCIRCUIT DRAWING DEFENSE SUPPLY CENTER COLUMBUS COLUMBUS, OHIO 43216-5000	SIZE A		5962-00B02
		REVISION LEVEL E	SHEET 56

Pads Location

pad	X	Y	type
78	-34.246	41.186	
79	-35.192	41.186	
80	-36.138	41.186	
81	-37.356	41.186	BLOCK
82	-38.302	41.186	BLOCK
83	-41.693	39.701	BLOCK_NOPO
84	-41.693	38.755	BLOCK
85	-41.693	37.809	BLOCK
86	-41.693	36.197	
87	-41.693	35.251	
88	-41.693	34.305	
89	-41.693	33.359	
90	-41.693	32.413	
91	-41.693	31.467	
92	-41.693	30.521	
93	-41.693	29.575	
94	-41.693	28.629	
95	-41.693	27.683	
96	-41.693	26.737	
97	-41.693	25.791	
98	-41.693	24.845	
99	-41.693	23.899	
100	-41.693	22.953	
101	-41.693	22.007	
102	-41.693	21.061	
103	-41.693	20.115	
104	-41.693	19.169	
105	-41.693	18.223	
106	-41.693	17.277	
107	-41.693	16.331	
108	-41.693	15.385	
109	-41.693	14.439	
110	-41.693	13.493	
111	-41.693	12.547	
112	-41.693	11.601	
113	-41.693	10.655	
114	-41.693	9.709	
115	-41.693	8.763	
116	-41.693	7.817	
117	-41.693	6.871	

FIGURE A-4. Die bonding pad locations and electrical functions. – Continued

STANDARD MICROCIRCUIT DRAWING DEFENSE SUPPLY CENTER COLUMBUS COLUMBUS, OHIO 43216-5000	SIZE A		5962-00B02
		REVISION LEVEL E	SHEET 57

Pads Location

pad	X	Y	type
118	-41.693	5.925	
119	-41.693	4.979	
120	-41.693	4.033	
121	-41.693	3.087	
122	-41.693	2.141	
123	-41.693	1.195	
124	-41.693	0.249	
125	-41.693	-0.697	
126	-41.693	-1.643	
127	-41.693	-2.589	
128	-41.693	-3.535	
129	-41.693	-4.481	
130	-41.693	-5.427	
131	-41.693	-6.373	
132	-41.693	-7.319	
133	-41.693	-8.265	
134	-41.693	-9.211	
135	-41.693	-10.157	
136	-41.693	-11.103	
137	-41.693	-12.049	
138	-41.693	-12.995	
139	-41.693	-13.941	
140	-41.693	-14.887	
141	-41.693	-15.833	
142	-41.693	-16.779	
143	-41.693	-17.725	
144	-41.693	-18.671	
145	-41.693	-19.617	
146	-41.693	-20.563	
147	-41.693	-21.509	
148	-41.693	-22.455	
149	-41.693	-23.401	
150	-41.693	-24.347	
151	-41.693	-25.293	
152	-41.693	-26.239	
153	-41.693	-27.185	
154	-41.693	-28.131	
155	-41.693	-29.077	
156	-41.693	-30.023	
157	-41.693	-30.969	

FIGURE A-4. Die bonding pad locations and electrical functions. – Continued

STANDARD MICROCIRCUIT DRAWING DEFENSE SUPPLY CENTER COLUMBUS COLUMBUS, OHIO 43216-5000	SIZE A		5962-00B02
		REVISION LEVEL E	SHEET 58

Pads Location

pad	X	Y	type
158	-41.693	-31.915	
159	-41.693	-32.861	
160	-41.693	-33.807	
161	-41.693	-34.753	
162	-41.693	-35.699	
163	-41.693	-36.645	POWER
164	-41.693	-37.591	POWER
165	-41.693	-38.537	POWER
166	-41.434	-41.186	POWER
167	-40.488	-41.186	POWER
168	-39.542	-41.186	POWER
169	-38.596	-41.186	POWER
170	-37.650	-41.186	POWER
171	-36.704	-41.186	
172	-35.758	-41.186	
173	-34.812	-41.186	
174	-33.866	-41.186	
175	-32.920	-41.186	
176	-31.974	-41.186	
177	-31.028	-41.186	
178	-30.082	-41.186	
179	-29.136	-41.186	
180	-28.190	-41.186	
181	-27.244	-41.186	
182	-26.298	-41.186	
183	-25.352	-41.186	
184	-24.406	-41.186	
185	-23.460	-41.186	
186	-22.514	-41.186	
187	-21.568	-41.186	
188	-20.622	-41.186	
189	-19.676	-41.186	
190	-18.730	-41.186	
191	-17.784	-41.186	
192	-16.838	-41.186	
193	-15.892	-41.186	
194	-14.946	-41.186	
195	-14.000	-41.186	
196	-13.054	-41.186	
197	-12.108	-41.186	

FIGURE A-4. Die bonding pad locations and electrical functions. – Continued

STANDARD MICROCIRCUIT DRAWING DEFENSE SUPPLY CENTER COLUMBUS COLUMBUS, OHIO 43216-5000	SIZE A		5962-00B02
		REVISION LEVEL E	SHEET 59

Pads Location

pad	X	Y	type
198	-11.162	-41.186	
199	-10.216	-41.186	
200	-9.270	-41.186	
201	-8.324	-41.186	
202	-7.378	-41.186	
203	-6.432	-41.186	
204	-5.486	-41.186	
205	-4.540	-41.186	
206	-3.594	-41.186	
207	-2.648	-41.186	
208	-1.702	-41.186	
209	-0.756	-41.186	
210	0.190	-41.186	
211	1.136	-41.186	
212	2.082	-41.186	
213	3.028	-41.186	
214	3.974	-41.186	
215	4.920	-41.186	
216	5.866	-41.186	
217	6.812	-41.186	
218	7.758	-41.186	
219	8.704	-41.186	
220	9.650	-41.186	
221	10.596	-41.186	
222	11.542	-41.186	
223	12.488	-41.186	
224	13.434	-41.186	
225	14.380	-41.186	
226	15.326	-41.186	
227	16.272	-41.186	
228	17.218	-41.186	
229	18.164	-41.186	
230	19.110	-41.186	
231	20.056	-41.186	
232	21.002	-41.186	
233	21.948	-41.186	
234	22.894	-41.186	
235	23.840	-41.186	
236	24.786	-41.186	
237	25.732	-41.186	

FIGURE A-4. Die bonding pad locations and electrical functions. – Continued

STANDARD MICROCIRCUIT DRAWING DEFENSE SUPPLY CENTER COLUMBUS COLUMBUS, OHIO 43216-5000	SIZE A		5962-00B02
		REVISION LEVEL E	SHEET 60

Pads Location

pad	X	Y	type
238	26.678	-41.186	
239	27.624	-41.186	
240	28.570	-41.186	
241	29.516	-41.186	
242	30.462	-41.186	
243	31.408	-41.186	
244	32.354	-41.186	
245	33.300	-41.186	
246	34.246	-41.186	
247	35.192	-41.186	
248	36.138	-41.186	
249	37.356	-41.186	BLOCK
250	38.302	-41.186	BLOCK
251	41.693	-39.701	BLOCK_NOPO
252	41.693	-38.755	BLOCK
253	41.693	-37.809	BLOCK
254	41.693	-36.197	
255	41.693	-35.251	
256	41.693	-34.305	
257	41.693	-33.359	
258	41.693	-32.413	
259	41.693	-31.467	
260	41.693	-30.521	
261	41.693	-29.575	
262	41.693	-28.629	
263	41.693	-27.683	
264	41.693	-26.737	
265	41.693	-25.791	
266	41.693	-24.845	
267	41.693	-23.899	
268	41.693	-22.953	
269	41.693	-22.007	
270	41.693	-21.061	
271	41.693	-20.115	
272	41.693	-19.169	
273	41.693	-18.223	
274	41.693	-17.277	
275	41.693	-16.331	
276	41.693	-15.385	
277	41.693	-14.439	

FIGURE A-4. Die bonding pad locations and electrical functions. – Continued

STANDARD MICROCIRCUIT DRAWING DEFENSE SUPPLY CENTER COLUMBUS COLUMBUS, OHIO 43216-5000	SIZE A		5962-00B02
		REVISION LEVEL E	SHEET 61

Pads Location

pad	X	Y	type
278	41.693	-13.493	
279	41.693	-12.547	
280	41.693	-11.601	
281	41.693	-10.655	
282	41.693	-9.709	
283	41.693	-8.763	
284	41.693	-7.817	
285	41.693	-6.871	
286	41.693	-5.925	
287	41.693	-4.979	
288	41.693	-4.033	
289	41.693	-3.087	
290	41.693	-2.141	
291	41.693	-1.195	
292	41.693	-0.249	
293	41.693	0.697	
294	41.693	1.643	
295	41.693	2.589	
296	41.693	3.535	
297	41.693	4.481	
298	41.693	5.427	
299	41.693	6.373	
300	41.693	7.319	
301	41.693	8.265	
302	41.693	9.211	
303	41.693	10.157	
304	41.693	11.103	
305	41.693	12.049	
306	41.693	12.995	
307	41.693	13.941	
308	41.693	14.887	
309	41.693	15.833	
310	41.693	16.779	
311	41.693	17.725	
312	41.693	18.671	
313	41.693	19.617	
314	41.693	20.563	
315	41.693	21.509	
316	41.693	22.455	
317	41.693	23.401	

FIGURE A-4. Die bonding pad locations and electrical functions. – Continued

STANDARD MICROCIRCUIT DRAWING DEFENSE SUPPLY CENTER COLUMBUS COLUMBUS, OHIO 43216-5000	SIZE A		5962-00B02
		REVISION LEVEL E	SHEET 62

Pads Location

pad	X	Y	type
318	41.693	24.347	
319	41.693	25.293	
320	41.693	26.239	
321	41.693	27.185	
322	41.693	28.131	
323	41.693	29.077	
324	41.693	30.023	
325	41.693	30.969	
326	41.693	31.915	
327	41.693	32.861	
328	41.693	33.807	
329	41.693	34.753	
330	41.693	35.699	
331	41.693	37.987	BLOCK
332	41.693	38.933	BLOCK
333	41.693	39.941	POWER

FIGURE A-4. Die bonding pad locations and electrical functions. - Continued

STANDARD MICROCIRCUIT DRAWING DEFENSE SUPPLY CENTER COLUMBUS COLUMBUS, OHIO 43216-5000	SIZE A		5962-00B02
		REVISION LEVEL E	SHEET 63

Due to the complexity of the device, a graphical representation of the pad locations is not available. This figure shall be maintained and available from the device manufacturer.

See subsequent pages for a table of pad locations.

Die bonding pad locations and electrical functions

Die physical dimensions.

Die size: 9910.15 x 9900.09 microns (with scribe line)

Die thickness: 475 microns

Interface materials.

Top metallization: Aluminium + Copper

Backside metallization: Bare Silicon

Glassivation.

Type: Oxinitride

Thickness: 10,000 Angstroms

Substrate: Single crystal silicon

Assembly related information.

Substrate potential: Not connected

Special assembly instructions: None

FIGURE A-5. Die bonding pad locations and electrical functions.

STANDARD MICROCIRCUIT DRAWING DEFENSE SUPPLY CENTER COLUMBUS COLUMBUS, OHIO 43216-5000	SIZE A		5962-00B02
		REVISION LEVEL E	SHEET 64

Pads Location

pad	X	Y	type
1	44.503	47.510	POWER
2	43.557	47.510	POWER
3	42.611	47.510	
4	41.665	47.510	
5	40.719	47.510	
6	39.773	47.510	
7	38.827	47.510	
8	37.881	47.510	
9	36.935	47.510	
10	35.989	47.510	
11	35.043	47.510	
12	34.097	47.510	
13	33.151	47.510	
14	32.205	47.510	
15	31.259	47.510	
16	30.313	47.510	
17	29.367	47.510	
18	28.421	47.510	
19	27.475	47.510	
20	26.529	47.510	
21	25.583	47.510	
22	24.637	47.510	
23	23.691	47.510	
24	22.745	47.510	
25	21.799	47.510	
26	20.853	47.510	
27	19.907	47.510	
28	18.961	47.510	
29	18.015	47.510	
30	17.069	47.510	
31	16.123	47.510	
32	15.177	47.510	
33	14.231	47.510	
34	13.285	47.510	
35	12.339	47.510	
36	11.393	47.510	
37	10.447	47.510	

FIGURE A-5. Die bonding pad locations and electrical functions. – Continued

STANDARD MICROCIRCUIT DRAWING DEFENSE SUPPLY CENTER COLUMBUS COLUMBUS, OHIO 43216-5000	SIZE A		5962-00B02
		REVISION LEVEL E	SHEET 65

Pads Location

pad	X	Y	type
38	9.501	47.510	
39	8.555	47.510	
40	7.609	47.510	
41	6.663	47.510	
42	5.717	47.510	
43	4.771	47.510	
44	3.825	47.510	
45	2.879	47.510	
46	1.933	47.510	
47	0.987	47.510	
48	0.041	47.510	
49	-0.905	47.510	
50	-1.851	47.510	
51	-2.797	47.510	
52	-3.743	47.510	
53	-4.689	47.510	
54	-5.635	47.510	
55	-6.581	47.510	
56	-7.527	47.510	
57	-8.473	47.510	
58	-9.419	47.510	
59	-10.365	47.510	
60	-11.311	47.510	
61	-12.257	47.510	
62	-13.203	47.510	
63	-14.149	47.510	
64	-15.095	47.510	
65	-16.041	47.510	
66	-16.987	47.510	
67	-17.933	47.510	
68	-18.879	47.510	
69	-19.825	47.510	
70	-20.771	47.510	
71	-21.717	47.510	
72	-22.663	47.510	
73	-23.609	47.510	
74	-24.555	47.510	
75	-25.501	47.510	
76	-26.447	47.510	
77	-27.393	47.510	

FIGURE A-5. Die bonding pad locations and electrical functions. - Continued

STANDARD MICROCIRCUIT DRAWING DEFENSE SUPPLY CENTER COLUMBUS COLUMBUS, OHIO 43216-5000	SIZE A		5962-00B02
		REVISION LEVEL E	SHEET 66

Pads Location

pad	X	Y	type
78	-28.339	47.510	
79	-29.285	47.510	
80	-30.231	47.510	
81	-31.177	47.510	
82	-32.123	47.510	
83	-33.069	47.510	
84	-34.015	47.510	
85	-34.961	47.510	
86	-35.907	47.510	
87	-36.853	47.510	
88	-37.799	47.510	
89	-38.745	47.510	
90	-39.691	47.510	
91	-40.637	47.510	
92	-41.583	47.510	
93	-43.264	47.510	BLOCK
94	-44.210	47.510	BLOCK
95	-47.601	46.025	BLOCK_NOPO
96	-47.601	45.079	BLOCK
97	-47.601	44.133	BLOCK
98	-47.601	42.521	
99	-47.601	41.575	
100	-47.601	40.629	
101	-47.601	39.683	
102	-47.601	38.737	
103	-47.601	37.791	
104	-47.601	36.845	
105	-47.601	35.899	
106	-47.601	34.953	
107	-47.601	34.007	
108	-47.601	33.061	
109	-47.601	32.115	
110	-47.601	31.169	
111	-47.601	30.223	
112	-47.601	29.277	
113	-47.601	28.331	
114	-47.601	27.385	
115	-47.601	26.439	
116	-47.601	25.493	
117	-47.601	24.547	

FIGURE A-5. Die bonding pad locations and electrical functions. - Continued

STANDARD MICROCIRCUIT DRAWING DEFENSE SUPPLY CENTER COLUMBUS COLUMBUS, OHIO 43216-5000	SIZE A		5962-00B02
		REVISION LEVEL E	SHEET 67

Pads Location

pad	X	Y	type
118	-47.601	23.601	
119	-47.601	22.655	
120	-47.601	21.709	
121	-47.601	20.763	
122	-47.601	19.817	
123	-47.601	18.871	
124	-47.601	17.925	
125	-47.601	16.979	
126	-47.601	16.033	
127	-47.601	15.087	
128	-47.601	14.141	
129	-47.601	13.195	
130	-47.601	12.249	
131	-47.601	11.303	
132	-47.601	10.357	
133	-47.601	9.411	
134	-47.601	8.465	
135	-47.601	7.519	
136	-47.601	6.573	
137	-47.601	5.627	
138	-47.601	4.681	
139	-47.601	3.735	
140	-47.601	2.789	
141	-47.601	1.843	
142	-47.601	0.897	
143	-47.601	-0.049	
144	-47.601	-0.995	
145	-47.601	-1.941	
146	-47.601	-2.887	
147	-47.601	-3.833	
148	-47.601	-4.779	
149	-47.601	-5.725	
150	-47.601	-6.671	
151	-47.601	-7.617	
152	-47.601	-8.563	
153	-47.601	-9.509	
154	-47.601	-10.455	
155	-47.601	-11.401	
156	-47.601	-12.347	
157	-47.601	-13.293	

FIGURE A-5. Die bonding pad locations and electrical functions. – Continued

STANDARD MICROCIRCUIT DRAWING DEFENSE SUPPLY CENTER COLUMBUS COLUMBUS, OHIO 43216-5000	SIZE A		5962-00B02
		REVISION LEVEL E	SHEET 68

Pads Location

pad	X	Y	type
158	-47.601	-14.239	
159	-47.601	-15.185	
160	-47.601	-16.131	
161	-47.601	-17.077	
162	-47.601	-18.023	
163	-47.601	-18.969	
164	-47.601	-19.915	
165	-47.601	-20.861	
166	-47.601	-21.807	
167	-47.601	-22.753	
168	-47.601	-23.699	
169	-47.601	-24.645	
170	-47.601	-25.591	
171	-47.601	-26.537	
172	-47.601	-27.483	
173	-47.601	-28.429	
174	-47.601	-29.375	
175	-47.601	-30.321	
176	-47.601	-31.267	
177	-47.601	-32.213	
178	-47.601	-33.159	
179	-47.601	-34.105	
180	-47.601	-35.051	
181	-47.601	-35.997	
182	-47.601	-36.943	
183	-47.601	-37.889	
184	-47.601	-38.835	
185	-47.601	-39.781	
186	-47.601	-40.727	
187	-47.601	-41.673	
188	-47.601	-42.619	
189	-47.601	-43.565	POWER
190	-47.601	-44.511	POWER
191	-47.601	-45.457	POWER
192	-47.341	-47.510	POWER
193	-46.395	-47.510	POWER
194	-45.449	-47.510	POWER
195	-44.503	-47.510	POWER
196	-43.557	-47.510	POWER
197	-42.611	-47.510	

FIGURE A-5. Die bonding pad locations and electrical functions. - Continued

STANDARD MICROCIRCUIT DRAWING DEFENSE SUPPLY CENTER COLUMBUS COLUMBUS, OHIO 43216-5000	SIZE A		5962-00B02
		REVISION LEVEL E	SHEET 69

Pads Location

pad	X	Y	type
198	-41.665	-47.510	
199	-40.719	-47.510	
200	-39.773	-47.510	
201	-38.827	-47.510	
202	-37.881	-47.510	
203	-36.935	-47.510	
204	-35.989	-47.510	
205	-35.043	-47.510	
206	-34.097	-47.510	
207	-33.151	-47.510	
208	-32.205	-47.510	
209	-31.259	-47.510	
210	-30.313	-47.510	
211	-29.367	-47.510	
212	-28.421	-47.510	
213	-27.475	-47.510	
214	-26.529	-47.510	
215	-25.583	-47.510	
216	-24.637	-47.510	
217	-23.691	-47.510	
218	-22.745	-47.510	
219	-21.799	-47.510	
220	-20.853	-47.510	
221	-19.907	-47.510	
222	-18.961	-47.510	
223	-18.015	-47.510	
224	-17.069	-47.510	
225	-16.123	-47.510	
226	-15.177	-47.510	
227	-14.231	-47.510	
228	-13.285	-47.510	
229	-12.339	-47.510	
230	-11.393	-47.510	
231	-10.447	-47.510	
232	-9.501	-47.510	
233	-8.555	-47.510	
234	-7.609	-47.510	
235	-6.663	-47.510	
236	-5.717	-47.510	
237	-4.771	-47.510	

FIGURE A-5. Die bonding pad locations and electrical functions. - Continued

STANDARD MICROCIRCUIT DRAWING DEFENSE SUPPLY CENTER COLUMBUS COLUMBUS, OHIO 43216-5000	SIZE A		5962-00B02
		REVISION LEVEL E	SHEET 70

Pads Location

pad	X	Y	type
238	-3.825	-47.510	
239	-2.879	-47.510	
240	-1.933	-47.510	
241	-0.987	-47.510	
242	-0.041	-47.510	
243	0.905	-47.510	
244	1.851	-47.510	
245	2.797	-47.510	
246	3.743	-47.510	
247	4.689	-47.510	
248	5.635	-47.510	
249	6.581	-47.510	
250	7.527	-47.510	
251	8.473	-47.510	
252	9.419	-47.510	
253	10.365	-47.510	
254	11.311	-47.510	
255	12.257	-47.510	
256	13.203	-47.510	
257	14.149	-47.510	
258	15.095	-47.510	
259	16.041	-47.510	
260	16.987	-47.510	
261	17.933	-47.510	
262	18.879	-47.510	
263	19.825	-47.510	
264	20.771	-47.510	
265	21.717	-47.510	
266	22.663	-47.510	
267	23.609	-47.510	
268	24.555	-47.510	
269	25.501	-47.510	
270	26.447	-47.510	
271	27.393	-47.510	
272	28.339	-47.510	
273	29.285	-47.510	
274	30.231	-47.510	
275	31.177	-47.510	
276	32.123	-47.510	
277	33.069	-47.510	

FIGURE A-5. Die bonding pad locations and electrical functions. - Continued

STANDARD MICROCIRCUIT DRAWING DEFENSE SUPPLY CENTER COLUMBUS COLUMBUS, OHIO 43216-5000	SIZE A		5962-00B02
		REVISION LEVEL E	SHEET 71

Pads Location

pad	X	Y	type
278	34.015	-47.510	
279	34.961	-47.510	
280	35.907	-47.510	
281	36.853	-47.510	
282	37.799	-47.510	
283	38.745	-47.510	
284	39.691	-47.510	
285	40.637	-47.510	
286	41.583	-47.510	
287	43.264	-47.510	BLOCK
288	44.210	-47.510	BLOCK
289	47.601	-46.025	BLOCK_NOPO
290	47.601	-45.079	BLOCK
291	47.601	-44.133	BLOCK
292	47.601	-42.521	
293	47.601	-41.575	
294	47.601	-40.629	
295	47.601	-39.683	
296	47.601	-38.737	
297	47.601	-37.791	
298	47.601	-36.845	
299	47.601	-35.899	
300	47.601	-34.953	
301	47.601	-34.007	
302	47.601	-33.061	
303	47.601	-32.115	
304	47.601	-31.169	
305	47.601	-30.223	
306	47.601	-29.277	
307	47.601	-28.331	
308	47.601	-27.385	
309	47.601	-26.439	
310	47.601	-25.493	
311	47.601	-24.547	
312	47.601	-23.601	
313	47.601	-22.655	
314	47.601	-21.709	
315	47.601	-20.763	
316	47.601	-19.817	
317	47.601	-18.871	

FIGURE A-5. Die bonding pad locations and electrical functions. - Continued

STANDARD MICROCIRCUIT DRAWING DEFENSE SUPPLY CENTER COLUMBUS COLUMBUS, OHIO 43216-5000	SIZE A		5962-00B02
		REVISION LEVEL E	SHEET 72

Pads Location

pad	X	Y	type
318	47.601	-17.925	
319	47.601	-16.979	
320	47.601	-16.033	
321	47.601	-15.087	
322	47.601	-14.141	
323	47.601	-13.195	
324	47.601	-12.249	
325	47.601	-11.303	
326	47.601	-10.357	
327	47.601	-9.411	
328	47.601	-8.465	
329	47.601	-7.519	
330	47.601	-6.573	
331	47.601	-5.627	
332	47.601	-4.681	
333	47.601	-3.735	
334	47.601	-2.789	
335	47.601	-1.843	
336	47.601	-0.897	
337	47.601	0.049	
338	47.601	0.995	
339	47.601	1.941	
340	47.601	2.887	
341	47.601	3.833	
342	47.601	4.779	
343	47.601	5.725	
344	47.601	6.671	
345	47.601	7.617	
346	47.601	8.563	
347	47.601	9.509	
348	47.601	10.455	
349	47.601	11.401	
350	47.601	12.347	
351	47.601	13.293	
352	47.601	14.239	
353	47.601	15.185	
354	47.601	16.131	
355	47.601	17.077	
356	47.601	18.023	
357	47.601	18.969	

FIGURE A-5. Die bonding pad locations and electrical functions. - Continued

STANDARD MICROCIRCUIT DRAWING DEFENSE SUPPLY CENTER COLUMBUS COLUMBUS, OHIO 43216-5000	SIZE A		5962-00B02
		REVISION LEVEL E	SHEET 73

Pads Location

pad	X	Y	type
358	47.601	19.915	
359	47.601	20.861	
360	47.601	21.807	
361	47.601	22.753	
362	47.601	23.699	
363	47.601	24.645	
364	47.601	25.591	
365	47.601	26.537	
366	47.601	27.483	
367	47.601	28.429	
368	47.601	29.375	
369	47.601	30.321	
370	47.601	31.267	
371	47.601	32.213	
372	47.601	33.159	
373	47.601	34.105	
374	47.601	35.051	
375	47.601	35.997	
376	47.601	36.943	
377	47.601	37.889	
378	47.601	38.835	
379	47.601	39.781	
380	47.601	40.727	
381	47.601	41.673	
382	47.601	42.619	
383	47.601	44.311	BLOCK
384	47.601	45.257	BLOCK
385	47.601	46.265	POWER

FIGURE A-5. Die bonding pad locations and electrical functions. - Continued

STANDARD MICROCIRCUIT DRAWING DEFENSE SUPPLY CENTER COLUMBUS COLUMBUS, OHIO 43216-5000	SIZE A		5962-00B02
		REVISION LEVEL E	SHEET 74

Due to the complexity of the device, a graphical representation of the pad locations is not available. This figure shall be maintained and available from the device manufacturer.

See subsequent pages for a table of pad locations.

Die bonding pad locations and electrical functions

Die physical dimensions.

Die size: 11530.09 x 11600.13 microns (with scribe line)

Die thickness: 475 microns

Interface materials.

Top metallization: Aluminium + Copper

Backside metallization: Bare Silicon

Glassivation.

Type: Oxinitride

Thickness: 10,000 Angstroms

Substrate: Single crystal silicon

Assembly related information.

Substrate potential: Not connected

Special assembly instructions: None

FIGURE A-6. Die bonding pad locations and electrical functions.

STANDARD MICROCIRCUIT DRAWING DEFENSE SUPPLY CENTER COLUMBUS COLUMBUS, OHIO 43216-5000	SIZE A		5962-00B02
		REVISION LEVEL E	SHEET 75

Pads Location

pad	X	Y	type
1	51.763	54.445	POWER
2	50.817	54.445	POWER
3	49.871	54.445	
4	48.925	54.445	
5	47.979	54.445	
6	47.033	54.445	
7	46.087	54.445	
8	45.141	54.445	
9	44.195	54.445	
10	43.249	54.445	
11	42.303	54.445	
12	41.357	54.445	
13	40.411	54.445	
14	39.465	54.445	
15	38.519	54.445	
16	37.573	54.445	
17	36.627	54.445	
18	35.681	54.445	
19	34.735	54.445	
20	33.789	54.445	
21	32.843	54.445	
22	31.897	54.445	
23	30.951	54.445	
24	30.005	54.445	
25	29.059	54.445	
26	28.113	54.445	
27	27.167	54.445	
28	26.221	54.445	
29	25.275	54.445	
30	24.329	54.445	
31	23.383	54.445	
32	22.437	54.445	
33	21.491	54.445	
34	20.545	54.445	
35	19.599	54.445	
36	18.653	54.445	
37	17.707	54.445	

FIGURE A-6. Die bonding pad locations and electrical functions. - Continued

STANDARD MICROCIRCUIT DRAWING DEFENSE SUPPLY CENTER COLUMBUS COLUMBUS, OHIO 43216-5000	SIZE A		5962-00B02
		REVISION LEVEL E	SHEET 76

Pads Location

pad	X	Y	type
38	16.761	54.445	
39	15.815	54.445	
40	14.869	54.445	
41	13.923	54.445	
42	12.977	54.445	
43	12.031	54.445	
44	11.085	54.445	
45	10.139	54.445	
46	9.193	54.445	
47	8.247	54.445	
48	7.301	54.445	
49	6.355	54.445	
50	5.409	54.445	
51	4.463	54.445	
52	3.517	54.445	
53	2.571	54.445	
54	1.625	54.445	
55	0.679	54.445	
56	-0.267	54.445	
57	-1.213	54.445	
58	-2.159	54.445	
59	-3.105	54.445	
60	-4.051	54.445	
61	-4.997	54.445	
62	-5.943	54.445	
63	-6.889	54.445	
64	-7.835	54.445	
65	-8.781	54.445	
66	-9.727	54.445	
67	-10.673	54.445	
68	-11.619	54.445	
69	-12.565	54.445	
70	-13.511	54.445	
71	-14.457	54.445	
72	-15.403	54.445	
73	-16.349	54.445	
74	-17.295	54.445	
75	-18.241	54.445	
76	-19.187	54.445	
77	-20.133	54.445	

FIGURE A-6. Die bonding pad locations and electrical functions. - Continued

STANDARD MICROCIRCUIT DRAWING DEFENSE SUPPLY CENTER COLUMBUS COLUMBUS, OHIO 43216-5000	SIZE A		5962-00B02
		REVISION LEVEL E	SHEET 77

Pads Location

pad	X	Y	type
78	-21.079	54.445	
79	-22.025	54.445	
80	-22.971	54.445	
81	-23.917	54.445	
82	-24.863	54.445	
83	-25.809	54.445	
84	-26.755	54.445	
85	-27.701	54.445	
86	-28.647	54.445	
87	-29.593	54.445	
88	-30.539	54.445	
89	-31.485	54.445	
90	-32.431	54.445	
91	-33.377	54.445	
92	-34.323	54.445	
93	-35.269	54.445	
94	-36.215	54.445	
95	-37.161	54.445	
96	-38.107	54.445	
97	-39.053	54.445	
98	-39.999	54.445	
99	-40.945	54.445	
100	-41.891	54.445	
101	-42.837	54.445	
102	-43.783	54.445	
103	-44.729	54.445	
104	-45.675	54.445	
105	-46.621	54.445	
106	-47.567	54.445	
107	-48.513	54.445	
108	-49.459	54.445	
109	-50.523	54.445	BLOCK
110	-51.469	54.445	BLOCK
111	-54.860	52.960	BLOCK_NOPO
112	-54.860	52.014	BLOCK
113	-54.860	51.068	BLOCK
114	-54.860	49.456	
115	-54.860	48.510	
116	-54.860	47.564	
117	-54.860	46.618	

FIGURE A-6. Die bonding pad locations and electrical functions. - Continued

STANDARD MICROCIRCUIT DRAWING DEFENSE SUPPLY CENTER COLUMBUS COLUMBUS, OHIO 43216-5000	SIZE A		5962-00B02
		REVISION LEVEL E	SHEET 78

Pads Location

pad	X	Y	type
118	-54.860	45.672	
119	-54.860	44.726	
120	-54.860	43.780	
121	-54.860	42.834	
122	-54.860	41.888	
123	-54.860	40.942	
124	-54.860	39.996	
125	-54.860	39.050	
126	-54.860	38.104	
127	-54.860	37.158	
128	-54.860	36.212	
129	-54.860	35.266	
130	-54.860	34.320	
131	-54.860	33.374	
132	-54.860	32.428	
133	-54.860	31.482	
134	-54.860	30.536	
135	-54.860	29.590	
136	-54.860	28.644	
137	-54.860	27.698	
138	-54.860	26.752	
139	-54.860	25.806	
140	-54.860	24.860	
141	-54.860	23.914	
142	-54.860	22.968	
143	-54.860	22.022	
144	-54.860	21.076	
145	-54.860	20.130	
146	-54.860	19.184	
147	-54.860	18.238	
148	-54.860	17.292	
149	-54.860	16.346	
150	-54.860	15.400	
151	-54.860	14.454	
152	-54.860	13.508	
153	-54.860	12.562	
154	-54.860	11.616	
155	-54.860	10.670	
156	-54.860	9.724	
157	-54.860	8.778	

FIGURE A-6. Die bonding pad locations and electrical functions. - Continued

STANDARD MICROCIRCUIT DRAWING DEFENSE SUPPLY CENTER COLUMBUS COLUMBUS, OHIO 43216-5000	SIZE A		5962-00B02
		REVISION LEVEL E	SHEET 79

Pads Location

pad	X	Y	type
158	-54.860	7.832	
159	-54.860	6.886	
160	-54.860	5.940	
161	-54.860	4.994	
162	-54.860	4.048	
163	-54.860	3.102	
164	-54.860	2.156	
165	-54.860	1.210	
166	-54.860	0.264	
167	-54.860	-0.682	
168	-54.860	-1.628	
169	-54.860	-2.574	
170	-54.860	-3.520	
171	-54.860	-4.466	
172	-54.860	-5.412	
173	-54.860	-6.358	
174	-54.860	-7.304	
175	-54.860	-8.250	
176	-54.860	-9.196	
177	-54.860	-10.142	
178	-54.860	-11.088	
179	-54.860	-12.034	
180	-54.860	-12.980	
181	-54.860	-13.926	
182	-54.860	-14.872	
183	-54.860	-15.818	
184	-54.860	-16.764	
185	-54.860	-17.710	
186	-54.860	-18.656	
187	-54.860	-19.602	
188	-54.860	-20.548	
189	-54.860	-21.494	
190	-54.860	-22.440	
191	-54.860	-23.386	
192	-54.860	-24.332	
193	-54.860	-25.278	
194	-54.860	-26.224	
195	-54.860	-27.170	
196	-54.860	-28.116	
197	-54.860	-29.062	

FIGURE A-6. Die bonding pad locations and electrical functions. - Continued

STANDARD MICROCIRCUIT DRAWING DEFENSE SUPPLY CENTER COLUMBUS COLUMBUS, OHIO 43216-5000	SIZE A		5962-00B02
		REVISION LEVEL E	SHEET 80

Pads Location

pad	X	Y	type
198	-54.860	-30.008	
199	-54.860	-30.954	
200	-54.860	-31.900	
201	-54.860	-32.846	
202	-54.860	-33.792	
203	-54.860	-34.738	
204	-54.860	-35.684	
205	-54.860	-36.630	
206	-54.860	-37.576	
207	-54.860	-38.522	
208	-54.860	-39.468	
209	-54.860	-40.414	
210	-54.860	-41.360	
211	-54.860	-42.306	
212	-54.860	-43.252	
213	-54.860	-44.198	
214	-54.860	-45.144	
215	-54.860	-46.090	
216	-54.860	-47.036	
217	-54.860	-47.982	
218	-54.860	-48.928	
219	-54.860	-49.874	POWER
220	-54.860	-50.820	POWER
221	-54.860	-51.766	POWER
222	-54.601	-54.445	POWER
223	-53.655	-54.445	POWER
224	-52.709	-54.445	POWER
225	-51.763	-54.445	POWER
226	-50.817	-54.445	POWER
227	-49.871	-54.445	
228	-48.925	-54.445	
229	-47.979	-54.445	
230	-47.033	-54.445	
231	-46.087	-54.445	
232	-45.141	-54.445	
233	-44.195	-54.445	
234	-43.249	-54.445	
235	-42.303	-54.445	
236	-41.357	-54.445	
237	-40.411	-54.445	

FIGURE A-6. Die bonding pad locations and electrical functions. - Continued

STANDARD MICROCIRCUIT DRAWING DEFENSE SUPPLY CENTER COLUMBUS COLUMBUS, OHIO 43216-5000	SIZE A		5962-00B02
		REVISION LEVEL E	SHEET 81

Pads Location

pad	X	Y	type
238	-39.465	-54.445	
239	-38.519	-54.445	
240	-37.573	-54.445	
241	-36.627	-54.445	
242	-35.681	-54.445	
243	-34.735	-54.445	
244	-33.789	-54.445	
245	-32.843	-54.445	
246	-31.897	-54.445	
247	-30.951	-54.445	
248	-30.005	-54.445	
249	-29.059	-54.445	
250	-28.113	-54.445	
251	-27.167	-54.445	
252	-26.221	-54.445	
253	-25.275	-54.445	
254	-24.329	-54.445	
255	-23.383	-54.445	
256	-22.437	-54.445	
257	-21.491	-54.445	
258	-20.545	-54.445	
259	-19.599	-54.445	
260	-18.653	-54.445	
261	-17.707	-54.445	
262	-16.761	-54.445	
263	-15.815	-54.445	
264	-14.869	-54.445	
265	-13.923	-54.445	
266	-12.977	-54.445	
267	-12.031	-54.445	
268	-11.085	-54.445	
269	-10.139	-54.445	
270	-9.193	-54.445	
271	-8.247	-54.445	
272	-7.301	-54.445	
273	-6.355	-54.445	
274	-5.409	-54.445	
275	-4.463	-54.445	
276	-3.517	-54.445	
277	-2.571	-54.445	

FIGURE A-6. Die bonding pad locations and electrical functions. - Continued

STANDARD MICROCIRCUIT DRAWING DEFENSE SUPPLY CENTER COLUMBUS COLUMBUS, OHIO 43216-5000	SIZE A		5962-00B02
		REVISION LEVEL E	SHEET 82

Pads Location

pad	X	Y	type
278	-1.625	-54.445	
279	-0.679	-54.445	
280	0.267	-54.445	
281	1.213	-54.445	
282	2.159	-54.445	
283	3.105	-54.445	
284	4.051	-54.445	
285	4.997	-54.445	
286	5.943	-54.445	
287	6.889	-54.445	
288	7.835	-54.445	
289	8.781	-54.445	
290	9.727	-54.445	
291	10.673	-54.445	
292	11.619	-54.445	
293	12.565	-54.445	
294	13.511	-54.445	
295	14.457	-54.445	
296	15.403	-54.445	
297	16.349	-54.445	
298	17.295	-54.445	
299	18.241	-54.445	
300	19.187	-54.445	
301	20.133	-54.445	
302	21.079	-54.445	
303	22.025	-54.445	
304	22.971	-54.445	
305	23.917	-54.445	
306	24.863	-54.445	
307	25.809	-54.445	
308	26.755	-54.445	
309	27.701	-54.445	
310	28.647	-54.445	
311	29.593	-54.445	
312	30.539	-54.445	
313	31.485	-54.445	
314	32.431	-54.445	
315	33.377	-54.445	
316	34.323	-54.445	
317	35.269	-54.445	

FIGURE A-6. Die bonding pad locations and electrical functions. - Continued

STANDARD MICROCIRCUIT DRAWING DEFENSE SUPPLY CENTER COLUMBUS COLUMBUS, OHIO 43216-5000	SIZE A		5962-00B02
		REVISION LEVEL E	SHEET 83

Pads Location

pad	X	Y	type
318	36.215	-54.445	
319	37.161	-54.445	
320	38.107	-54.445	
321	39.053	-54.445	
322	39.999	-54.445	
323	40.945	-54.445	
324	41.891	-54.445	
325	42.837	-54.445	
326	43.783	-54.445	
327	44.729	-54.445	
328	45.675	-54.445	
329	46.621	-54.445	
330	47.567	-54.445	
331	48.513	-54.445	
332	49.459	-54.445	
333	50.523	-54.445	BLOCK
334	51.469	-54.445	BLOCK
335	54.860	-52.960	BLOCK_NOPO
336	54.860	-52.014	BLOCK
337	54.860	-51.068	BLOCK
338	54.860	-49.456	
339	54.860	-48.510	
340	54.860	-47.564	
341	54.860	-46.618	
342	54.860	-45.672	
343	54.860	-44.726	
344	54.860	-43.780	
345	54.860	-42.834	
346	54.860	-41.888	
347	54.860	-40.942	
348	54.860	-39.996	
349	54.860	-39.050	
350	54.860	-38.104	
351	54.860	-37.158	
352	54.860	-36.212	
353	54.860	-35.266	
354	54.860	-34.320	
355	54.860	-33.374	
356	54.860	-32.428	
357	54.860	-31.482	

FIGURE A-6. Die bonding pad locations and electrical functions. - Continued

STANDARD MICROCIRCUIT DRAWING DEFENSE SUPPLY CENTER COLUMBUS COLUMBUS, OHIO 43216-5000	SIZE A		5962-00B02
		REVISION LEVEL E	SHEET 84

Pads Location

pad	X	Y	type
358	54.860	-30.536	
359	54.860	-29.590	
360	54.860	-28.644	
361	54.860	-27.698	
362	54.860	-26.752	
363	54.860	-25.806	
364	54.860	-24.860	
365	54.860	-23.914	
366	54.860	-22.968	
367	54.860	-22.022	
368	54.860	-21.076	
369	54.860	-20.130	
370	54.860	-19.184	
371	54.860	-18.238	
372	54.860	-17.292	
373	54.860	-16.346	
374	54.860	-15.400	
375	54.860	-14.454	
376	54.860	-13.508	
377	54.860	-12.562	
378	54.860	-11.616	
379	54.860	-10.670	
380	54.860	-9.724	
381	54.860	-8.778	
382	54.860	-7.832	
383	54.860	-6.886	
384	54.860	-5.940	
385	54.860	-4.994	
386	54.860	-4.048	
387	54.860	-3.102	
388	54.860	-2.156	
389	54.860	-1.210	
390	54.860	-0.264	
391	54.860	0.682	
392	54.860	1.628	
393	54.860	2.574	
394	54.860	3.520	
395	54.860	4.466	
396	54.860	5.412	
397	54.860	6.358	

FIGURE A-6. Die bonding pad locations and electrical functions. - Continued

STANDARD MICROCIRCUIT DRAWING DEFENSE SUPPLY CENTER COLUMBUS COLUMBUS, OHIO 43216-5000	SIZE A		5962-00B02
		REVISION LEVEL E	SHEET 85

Pads Location

pad	X	Y	type
398	54.860	7.304	
399	54.860	8.250	
400	54.860	9.196	
401	54.860	10.142	
402	54.860	11.088	
403	54.860	12.034	
404	54.860	12.980	
405	54.860	13.926	
406	54.860	14.872	
407	54.860	15.818	
408	54.860	16.764	
409	54.860	17.710	
410	54.860	18.656	
411	54.860	19.602	
412	54.860	20.548	
413	54.860	21.494	
414	54.860	22.440	
415	54.860	23.386	
416	54.860	24.332	
417	54.860	25.278	
418	54.860	26.224	
419	54.860	27.170	
420	54.860	28.116	
421	54.860	29.062	
422	54.860	30.008	
423	54.860	30.954	
424	54.860	31.900	
425	54.860	32.846	
426	54.860	33.792	
427	54.860	34.738	
428	54.860	35.684	
429	54.860	36.630	
430	54.860	37.576	
431	54.860	38.522	
432	54.860	39.468	
433	54.860	40.414	
434	54.860	41.360	
435	54.860	42.306	
436	54.860	43.252	
437	54.860	44.198	

FIGURE A-6. Die bonding pad locations and electrical functions. - Continued

STANDARD MICROCIRCUIT DRAWING DEFENSE SUPPLY CENTER COLUMBUS COLUMBUS, OHIO 43216-5000	SIZE A		5962-00B02
		REVISION LEVEL E	SHEET 86

Pads Location

pad	X	Y	type
438	54.860	45.144	
439	54.860	46.090	
440	54.860	47.036	
441	54.860	47.982	
442	54.860	48.928	
443	54.860	51.246	BLOCK
444	54.860	52.192	BLOCK
445	54.860	53.200	POWER

FIGURE A-6. Die bonding pad locations and electrical functions. - Continued

STANDARD MICROCIRCUIT DRAWING DEFENSE SUPPLY CENTER COLUMBUS COLUMBUS, OHIO 43216-5000	SIZE A		5962-00B02
		REVISION LEVEL E	SHEET 87

Due to the complexity of the device, a graphical representation of the pad locations is not available. This figure shall be maintained and available from the device manufacturer.

See subsequent pages for a table of pad locations.

Die bonding pad locations and electrical functions

Die physical dimensions.

Die size: 13020.13 x 12950.12 microns (with scribe line)

Die thickness: 475 microns

Interface materials.

Top metallization: Aluminium + Copper

Backside metallization: Bare Silicon

Glassivation.

Type: Oxinitride

Thickness: 10,000 Angstroms

Substrate: Single crystal silicon

Assembly related information.

Substrate potential: Not connected

Special assembly instructions: None

FIGURE A-7. Die bonding pad locations and electrical functions.

STANDARD MICROCIRCUIT DRAWING DEFENSE SUPPLY CENTER COLUMBUS COLUMBUS, OHIO 43216-5000	SIZE A		5962-00B02
		REVISION LEVEL E	SHEET 88

Pads Location

pad	X	Y	type
1	59.253	61.981	POWER
2	58.307	61.981	POWER
3	57.361	61.981	
4	56.415	61.981	
5	55.469	61.981	
6	54.523	61.981	
7	53.577	61.981	
8	52.631	61.981	
9	51.685	61.981	
10	50.739	61.981	
11	49.793	61.981	
12	48.847	61.981	
13	47.901	61.981	
14	46.955	61.981	
15	46.009	61.981	
16	45.063	61.981	
17	44.117	61.981	
18	43.171	61.981	
19	42.225	61.981	
20	41.279	61.981	
21	40.333	61.981	
22	39.387	61.981	
23	38.441	61.981	
24	37.495	61.981	
25	36.549	61.981	
26	35.603	61.981	
27	34.657	61.981	
28	33.711	61.981	
29	32.765	61.981	
30	31.819	61.981	
31	30.873	61.981	
32	29.927	61.981	
33	28.981	61.981	
34	28.035	61.981	
35	27.089	61.981	
36	26.143	61.981	
37	25.197	61.981	

FIGURE A-7. Die bonding pad locations and electrical functions. – Continued

STANDARD MICROCIRCUIT DRAWING DEFENSE SUPPLY CENTER COLUMBUS COLUMBUS, OHIO 43216-5000	SIZE A		5962-00B02
		REVISION LEVEL E	SHEET 89

Pads Location

pad	X	Y	type
38	24.251	61.981	
39	23.305	61.981	
40	22.359	61.981	
41	21.413	61.981	
42	20.467	61.981	
43	19.521	61.981	
44	18.575	61.981	
45	17.629	61.981	
46	16.683	61.981	
47	15.737	61.981	
48	14.791	61.981	
49	13.845	61.981	
50	12.899	61.981	
51	11.953	61.981	
52	11.007	61.981	
53	10.061	61.981	
54	9.115	61.981	
55	8.169	61.981	
56	7.223	61.981	
57	6.277	61.981	
58	5.331	61.981	
59	4.385	61.981	
60	3.439	61.981	
61	2.493	61.981	
62	1.547	61.981	
63	0.601	61.981	
64	-0.345	61.981	
65	-1.291	61.981	
66	-2.237	61.981	
67	-3.183	61.981	
68	-4.129	61.981	
69	-5.075	61.981	
70	-6.021	61.981	
71	-6.967	61.981	
72	-7.913	61.981	
73	-8.859	61.981	
74	-9.805	61.981	
75	-10.751	61.981	
76	-11.697	61.981	
77	-12.643	61.981	

FIGURE A-7. Die bonding pad locations and electrical functions. – Continued

STANDARD MICROCIRCUIT DRAWING DEFENSE SUPPLY CENTER COLUMBUS COLUMBUS, OHIO 43216-5000	SIZE A		5962-00B02
		REVISION LEVEL E	SHEET 90

Pads Location

pad	X	Y	type
78	-13.589	61.981	
79	-14.535	61.981	
80	-15.481	61.981	
81	-16.427	61.981	
82	-17.373	61.981	
83	-18.319	61.981	
84	-19.265	61.981	
85	-20.211	61.981	
86	-21.157	61.981	
87	-22.103	61.981	
88	-23.049	61.981	
89	-23.995	61.981	
90	-24.941	61.981	
91	-25.887	61.981	
92	-26.833	61.981	
93	-27.779	61.981	
94	-28.725	61.981	
95	-29.671	61.981	
96	-30.617	61.981	
97	-31.563	61.981	
98	-32.509	61.981	
99	-33.455	61.981	
100	-34.401	61.981	
101	-35.347	61.981	
102	-36.293	61.981	
103	-37.239	61.981	
104	-38.185	61.981	
105	-39.131	61.981	
106	-40.077	61.981	
107	-41.023	61.981	
108	-41.969	61.981	
109	-42.915	61.981	
110	-43.861	61.981	
111	-44.807	61.981	
112	-45.753	61.981	
113	-46.699	61.981	
114	-47.645	61.981	
115	-48.591	61.981	
116	-49.537	61.981	
117	-50.483	61.981	

FIGURE A-7. Die bonding pad locations and electrical functions. – Continued

STANDARD MICROCIRCUIT DRAWING DEFENSE SUPPLY CENTER COLUMBUS COLUMBUS, OHIO 43216-5000	SIZE A		5962-00B02
		REVISION LEVEL E	SHEET 91

Pads Location

pad	X	Y	type
118	-51.429	61.981	
119	-52.375	61.981	
120	-53.321	61.981	
121	-54.267	61.981	
122	-55.213	61.981	
123	-56.159	61.981	
124	-58.013	61.981	BLOCK
125	-58.959	61.981	BLOCK
126	-62.350	60.496	BLOCK_NOPO
127	-62.350	59.550	BLOCK
128	-62.350	58.604	BLOCK
129	-62.350	56.992	
130	-62.350	56.046	
131	-62.350	55.100	
132	-62.350	54.154	
133	-62.350	53.208	
134	-62.350	52.262	
135	-62.350	51.316	
136	-62.350	50.370	
137	-62.350	49.424	
138	-62.350	48.478	
139	-62.350	47.532	
140	-62.350	46.586	
141	-62.350	45.640	
142	-62.350	44.694	
143	-62.350	43.748	
144	-62.350	42.802	
145	-62.350	41.856	
146	-62.350	40.910	
147	-62.350	39.964	
148	-62.350	39.018	
149	-62.350	38.072	
150	-62.350	37.126	
151	-62.350	36.180	
152	-62.350	35.234	
153	-62.350	34.288	
154	-62.350	33.342	
155	-62.350	32.396	
156	-62.350	31.450	
157	-62.350	30.504	

FIGURE A-7. Die bonding pad locations and electrical functions. – Continued

STANDARD MICROCIRCUIT DRAWING DEFENSE SUPPLY CENTER COLUMBUS COLUMBUS, OHIO 43216-5000	SIZE A		5962-00B02
		REVISION LEVEL E	SHEET 92

Pads Location

pad	X	Y	type
158	-62.350	29.558	
159	-62.350	28.612	
160	-62.350	27.666	
161	-62.350	26.720	
162	-62.350	25.774	
163	-62.350	24.828	
164	-62.350	23.882	
165	-62.350	22.936	
166	-62.350	21.990	
167	-62.350	21.044	
168	-62.350	20.098	
169	-62.350	19.152	
170	-62.350	18.206	
171	-62.350	17.260	
172	-62.350	16.314	
173	-62.350	15.368	
174	-62.350	14.422	
175	-62.350	13.476	
176	-62.350	12.530	
177	-62.350	11.584	
178	-62.350	10.638	
179	-62.350	9.692	
180	-62.350	8.746	
181	-62.350	7.800	
182	-62.350	6.854	
183	-62.350	5.908	
184	-62.350	4.962	
185	-62.350	4.016	
186	-62.350	3.070	
187	-62.350	2.124	
188	-62.350	1.178	
189	-62.350	0.232	
190	-62.350	-0.714	
191	-62.350	-1.660	
192	-62.350	-2.606	
193	-62.350	-3.552	
194	-62.350	-4.498	
195	-62.350	-5.444	
196	-62.350	-6.390	
197	-62.350	-7.336	

FIGURE A-7. Die bonding pad locations and electrical functions. – Continued

STANDARD MICROCIRCUIT DRAWING DEFENSE SUPPLY CENTER COLUMBUS COLUMBUS, OHIO 43216-5000	SIZE A		5962-00B02
		REVISION LEVEL E	SHEET 93

Pads Location

pad	X	Y	type
198	-62.350	-8.282	
199	-62.350	-9.228	
200	-62.350	-10.174	
201	-62.350	-11.120	
202	-62.350	-12.066	
203	-62.350	-13.012	
204	-62.350	-13.958	
205	-62.350	-14.904	
206	-62.350	-15.850	
207	-62.350	-16.796	
208	-62.350	-17.742	
209	-62.350	-18.688	
210	-62.350	-19.634	
211	-62.350	-20.580	
212	-62.350	-21.526	
213	-62.350	-22.472	
214	-62.350	-23.418	
215	-62.350	-24.364	
216	-62.350	-25.310	
217	-62.350	-26.256	
218	-62.350	-27.202	
219	-62.350	-28.148	
220	-62.350	-29.094	
221	-62.350	-30.040	
222	-62.350	-30.986	
223	-62.350	-31.932	
224	-62.350	-32.878	
225	-62.350	-33.824	
226	-62.350	-34.770	
227	-62.350	-35.716	
228	-62.350	-36.662	
229	-62.350	-37.608	
230	-62.350	-38.554	
231	-62.350	-39.500	
232	-62.350	-40.446	
233	-62.350	-41.392	
234	-62.350	-42.338	
235	-62.350	-43.284	
236	-62.350	-44.230	
237	-62.350	-45.176	

FIGURE A-7. Die bonding pad locations and electrical functions. – Continued

STANDARD MICROCIRCUIT DRAWING DEFENSE SUPPLY CENTER COLUMBUS COLUMBUS, OHIO 43216-5000	SIZE A		5962-00B02
		REVISION LEVEL E	SHEET 94

Pads Location

pad	X	Y	type
238	-62.350	-46.122	
239	-62.350	-47.068	
240	-62.350	-48.014	
241	-62.350	-48.960	
242	-62.350	-49.906	
243	-62.350	-50.852	
244	-62.350	-51.798	
245	-62.350	-52.744	
246	-62.350	-53.690	
247	-62.350	-54.636	
248	-62.350	-55.582	
249	-62.350	-56.528	
250	-62.350	-57.474	POWER
251	-62.350	-58.420	POWER
252	-62.350	-59.366	POWER
253	-62.091	-61.981	POWER
254	-61.145	-61.981	POWER
255	-60.199	-61.981	POWER
256	-59.253	-61.981	POWER
257	-58.307	-61.981	POWER
258	-57.361	-61.981	
259	-56.415	-61.981	
260	-55.469	-61.981	
261	-54.523	-61.981	
262	-53.577	-61.981	
263	-52.631	-61.981	
264	-51.685	-61.981	
265	-50.739	-61.981	
266	-49.793	-61.981	
267	-48.847	-61.981	
268	-47.901	-61.981	
269	-46.955	-61.981	
270	-46.009	-61.981	
271	-45.063	-61.981	
272	-44.117	-61.981	
273	-43.171	-61.981	
274	-42.225	-61.981	
275	-41.279	-61.981	
276	-40.333	-61.981	
277	-39.387	-61.981	

FIGURE A-7. Die bonding pad locations and electrical functions. – Continued

STANDARD MICROCIRCUIT DRAWING DEFENSE SUPPLY CENTER COLUMBUS COLUMBUS, OHIO 43216-5000	SIZE A		5962-00B02
		REVISION LEVEL E	SHEET 95

Pads Location

pad	X	Y	type
278	-38.441	-61.981	
279	-37.495	-61.981	
280	-36.549	-61.981	
281	-35.603	-61.981	
282	-34.657	-61.981	
283	-33.711	-61.981	
284	-32.765	-61.981	
285	-31.819	-61.981	
286	-30.873	-61.981	
287	-29.927	-61.981	
288	-28.981	-61.981	
289	-28.035	-61.981	
290	-27.089	-61.981	
291	-26.143	-61.981	
292	-25.197	-61.981	
293	-24.251	-61.981	
294	-23.305	-61.981	
295	-22.359	-61.981	
296	-21.413	-61.981	
297	-20.467	-61.981	
298	-19.521	-61.981	
299	-18.575	-61.981	
300	-17.629	-61.981	
301	-16.683	-61.981	
302	-15.737	-61.981	
303	-14.791	-61.981	
304	-13.845	-61.981	
305	-12.899	-61.981	
306	-11.953	-61.981	
307	-11.007	-61.981	
308	-10.061	-61.981	
309	-9.115	-61.981	
310	-8.169	-61.981	
311	-7.223	-61.981	
312	-6.277	-61.981	
313	-5.331	-61.981	
314	-4.385	-61.981	
315	-3.439	-61.981	
316	-2.493	-61.981	
317	-1.547	-61.981	

FIGURE A-7. Die bonding pad locations and electrical functions. – Continued

STANDARD MICROCIRCUIT DRAWING DEFENSE SUPPLY CENTER COLUMBUS COLUMBUS, OHIO 43216-5000	SIZE A		5962-00B02
		REVISION LEVEL E	SHEET 96

Pads Location

pad	X	Y	type
318	-0.601	-61.981	
319	0.345	-61.981	
320	1.291	-61.981	
321	2.237	-61.981	
322	3.183	-61.981	
323	4.129	-61.981	
324	5.075	-61.981	
325	6.021	-61.981	
326	6.967	-61.981	
327	7.913	-61.981	
328	8.859	-61.981	
329	9.805	-61.981	
330	10.751	-61.981	
331	11.697	-61.981	
332	12.643	-61.981	
333	13.589	-61.981	
334	14.535	-61.981	
335	15.481	-61.981	
336	16.427	-61.981	
337	17.373	-61.981	
338	18.319	-61.981	
339	19.265	-61.981	
340	20.211	-61.981	
341	21.157	-61.981	
342	22.103	-61.981	
343	23.049	-61.981	
344	23.995	-61.981	
345	24.941	-61.981	
346	25.887	-61.981	
347	26.833	-61.981	
348	27.779	-61.981	
349	28.725	-61.981	
350	29.671	-61.981	
351	30.617	-61.981	
352	31.563	-61.981	
353	32.509	-61.981	
354	33.455	-61.981	
355	34.401	-61.981	
356	35.347	-61.981	
357	36.293	-61.981	

FIGURE A-7. Die bonding pad locations and electrical functions. – Continued

STANDARD MICROCIRCUIT DRAWING DEFENSE SUPPLY CENTER COLUMBUS COLUMBUS, OHIO 43216-5000	SIZE A		5962-00B02
		REVISION LEVEL E	SHEET 97

Pads Location

pad	X	Y	type
358	37.239	-61.981	
359	38.185	-61.981	
360	39.131	-61.981	
361	40.077	-61.981	
362	41.023	-61.981	
363	41.969	-61.981	
364	42.915	-61.981	
365	43.861	-61.981	
366	44.807	-61.981	
367	45.753	-61.981	
368	46.699	-61.981	
369	47.645	-61.981	
370	48.591	-61.981	
371	49.537	-61.981	
372	50.483	-61.981	
373	51.429	-61.981	
374	52.375	-61.981	
375	53.321	-61.981	
376	54.267	-61.981	
377	55.213	-61.981	
378	56.159	-61.981	
379	58.013	-61.981	BLOCK
380	58.959	-61.981	BLOCK
381	62.350	-60.496	BLOCK_NOPO
382	62.350	-59.550	BLOCK
383	62.350	-58.604	BLOCK
384	62.350	-56.992	
385	62.350	-56.046	
386	62.350	-55.100	
387	62.350	-54.154	
388	62.350	-53.208	
389	62.350	-52.262	
390	62.350	-51.316	
391	62.350	-50.370	
392	62.350	-49.424	
393	62.350	-48.478	
394	62.350	-47.532	
395	62.350	-46.586	
396	62.350	-45.640	
397	62.350	-44.694	

FIGURE A-7. Die bonding pad locations and electrical functions. – Continued

STANDARD MICROCIRCUIT DRAWING DEFENSE SUPPLY CENTER COLUMBUS COLUMBUS, OHIO 43216-5000	SIZE A		5962-00B02
		REVISION LEVEL E	SHEET 98

Pads Location

pad	X	Y	type
398	62.350	-43.748	
399	62.350	-42.802	
400	62.350	-41.856	
401	62.350	-40.910	
402	62.350	-39.964	
403	62.350	-39.018	
404	62.350	-38.072	
405	62.350	-37.126	
406	62.350	-36.180	
407	62.350	-35.234	
408	62.350	-34.288	
409	62.350	-33.342	
410	62.350	-32.396	
411	62.350	-31.450	
412	62.350	-30.504	
413	62.350	-29.558	
414	62.350	-28.612	
415	62.350	-27.666	
416	62.350	-26.720	
417	62.350	-25.774	
418	62.350	-24.828	
419	62.350	-23.882	
420	62.350	-22.936	
421	62.350	-21.990	
422	62.350	-21.044	
423	62.350	-20.098	
424	62.350	-19.152	
425	62.350	-18.206	
426	62.350	-17.260	
427	62.350	-16.314	
428	62.350	-15.368	
429	62.350	-14.422	
430	62.350	-13.476	
431	62.350	-12.530	
432	62.350	-11.584	
433	62.350	-10.638	
434	62.350	-9.692	
435	62.350	-8.746	
436	62.350	-7.800	
437	62.350	-6.854	

FIGURE A-7. Die bonding pad locations and electrical functions. – Continued

STANDARD MICROCIRCUIT DRAWING DEFENSE SUPPLY CENTER COLUMBUS COLUMBUS, OHIO 43216-5000	SIZE A		5962-00B02
		REVISION LEVEL E	SHEET 99

Pads Location

pad	X	Y	type
438	62.350	-5.908	
439	62.350	-4.962	
440	62.350	-4.016	
441	62.350	-3.070	
442	62.350	-2.124	
443	62.350	-1.178	
444	62.350	-0.232	
445	62.350	0.714	
446	62.350	1.660	
447	62.350	2.606	
448	62.350	3.552	
449	62.350	4.498	
450	62.350	5.444	
451	62.350	6.390	
452	62.350	7.336	
453	62.350	8.282	
454	62.350	9.228	
455	62.350	10.174	
456	62.350	11.120	
457	62.350	12.066	
458	62.350	13.012	
459	62.350	13.958	
460	62.350	14.904	
461	62.350	15.850	
462	62.350	16.796	
463	62.350	17.742	
464	62.350	18.688	
465	62.350	19.634	
466	62.350	20.580	
467	62.350	21.526	
468	62.350	22.472	
469	62.350	23.418	
470	62.350	24.364	
471	62.350	25.310	
472	62.350	26.256	
473	62.350	27.202	
474	62.350	28.148	
475	62.350	29.094	
476	62.350	30.040	
477	62.350	30.986	

FIGURE A-7. Die bonding pad locations and electrical functions. – Continued

STANDARD MICROCIRCUIT DRAWING DEFENSE SUPPLY CENTER COLUMBUS COLUMBUS, OHIO 43216-5000	SIZE A		5962-00B02
		REVISION LEVEL E	SHEET 100

Pads Location

pad	X	Y	type
478	62.350	31.932	
479	62.350	32.878	
480	62.350	33.824	
481	62.350	34.770	
482	62.350	35.716	
483	62.350	36.662	
484	62.350	37.608	
485	62.350	38.554	
486	62.350	39.500	
487	62.350	40.446	
488	62.350	41.392	
489	62.350	42.338	
490	62.350	43.284	
491	62.350	44.230	
492	62.350	45.176	
493	62.350	46.122	
494	62.350	47.068	
495	62.350	48.014	
496	62.350	48.960	
497	62.350	49.906	
498	62.350	50.852	
499	62.350	51.798	
500	62.350	52.744	
501	62.350	53.690	
502	62.350	54.636	
503	62.350	55.582	
504	62.350	56.528	
505	62.350	58.782	BLOCK
506	62.350	59.728	BLOCK
507	62.350	60.737	POWER

FIGURE A-7. Die bonding pad locations and electrical functions. - Continued

STANDARD MICROCIRCUIT DRAWING DEFENSE SUPPLY CENTER COLUMBUS COLUMBUS, OHIO 43216-5000	SIZE A		5962-00B02
		REVISION LEVEL E	SHEET 101

DATE: 02-03-08

Approved sources of supply for SMD 5962-00B02 are listed below for immediate acquisition information only and shall be added to MIL-HDBK-103 and QML-38535 during the next revision. MIL-HDBK-103 and QML-38535 will be revised to include the addition or deletion of sources. The vendors listed below have agreed to this drawing and a certificate of compliance has been submitted to and accepted by DSCC-VA. This bulletin is superseded by the next dated revision of MIL-HDBK-103 and QML-38535.

Standard microcircuit drawing PIN <u>1</u> /	Vendor CAGE number	Vendor similar PIN <u>2</u> /
5962-00B0201Q_C <u>3</u> / 5962-00B0201V_C <u>3</u> / 5962-00B0201Q9A <u>4</u> / 5962-00B0201V9A <u>4</u> /	F7400	MG2044E MG2044E MM0-G2044EHxxxMQ SM0-G2044EHxxxSV
5962-00B0202Q_C <u>3</u> / 5962-00B0202V_C <u>3</u> / 5962-00B0202Q9A <u>4</u> / 5962-00B0202V9A <u>4</u> /	F7400	MG2091E MG2091E MM0-G2091EHxxxMQ SM0-G2091EHxxxSV
5962-00B0203Q_C <u>3</u> / 5962-00B0203V_C <u>3</u> / 5962-00B0203Q9A <u>4</u> / 5962-00B0203V9A <u>4</u> /	F7400	MG2140E MG2140E MM0-G2140EHxxxMQ SM0-G2140EHxxxSV
5962-00B0204Q_C <u>3</u> / 5962-00B0204V_C <u>3</u> / 5962-00B0204Q9A <u>4</u> / 5962-00B0204V9A <u>4</u> /	F7400	MG2194E MG2194E MM0-G2194EHxxxMQ SM0-G2194EHxxxSV
5962-00B0205Q_C <u>3</u> / 5962-00B0205V_C <u>3</u> / 5962-00B0205Q9A <u>4</u> / 5962-00B0205V9A <u>4</u> /	F7400	MG2265E MG2265E MM0-G2265EHxxxMQ SM0-G2265EHxxxSV
5962-00B0206Q_C <u>3</u> / 5962-00B0206V_C <u>3</u> / 5962-00B0206Q9A <u>4</u> / 5962-00B0206V9A <u>4</u> /	F7400	MG2360E MG2360E MM0-G2360EHxxxMQ SM0-G2360EHxxxSV
5962-00B0207Q_C <u>3</u> / 5962-00B0207V_C <u>3</u> / 5962-00B0207Q9A <u>4</u> / 5962-00B0207V9A <u>4</u> /	F7400	MG2480E MG2480E MM0-G2480EHxxxMQ SM0-G2480EHxxxSV

[查询"5962-00B02"供应商](#)

Standard microcircuit drawing PIN <u>1/</u>	Vendor CAGE number	Vendor similar PIN <u>2/</u>
5962-00B0209Q_C <u>3/</u> 5962-00B0209Q9A <u>4/</u>	F7400	MG2044 MM0-G2044xxxMQ
5962-00B0210Q_C <u>3/</u> 5962-00B0210Q9A <u>4/</u>	F7400	MG2091 MM0-G2091xxxMQ
5962-00B0211Q_C <u>3/</u> 5962-00B0211Q9A <u>4/</u>	F7400	MG2140 MM0-G2140xxxMQ
5962-00B0212Q_C <u>3/</u> 5962-00B0212Q9A <u>4/</u>	F7400	MG2194 MM0-G2194xxxMQ
5962-00B0213Q_C <u>3/</u> 5962-00B0213Q9A <u>4/</u>	F7400	MG2265 MM0-G2265xxxMQ
5962-00B0214Q_C <u>3/</u> 5962-00B0214Q9A <u>4/</u>	F7400	MG2360 MM0-G2360xxxMQ
5962-00B0215Q_C <u>3/</u> 5962-00B0215Q9A <u>4/</u>	F7400	MG2480 MM0-G2480xxxMQ
5962-00B0216Q_C <u>3/</u> 5962-00B0216V_C <u>3/</u> 5962-00B0216Q9A <u>4/</u> 5962-00B0216V9A <u>4/</u>	F7400	MG2M044E MG2M044E MM0-G2M044EHxxxMQ SM0-G2M044EHxxxSV
5962-00B0217Q_C <u>3/</u> 5962-00B0217V_C <u>3/</u> 5962-00B0217Q9A <u>4/</u> 5962-00B0217V9A <u>4/</u>	F7400	MG2M091E MG2M091E MM0-G2M091EHxxxMQ SM0-G2M091EHxxxSV
5962-00B0218Q_C <u>3/</u> 5962-00B0218V_C <u>3/</u> 5962-00B0218Q9A <u>4/</u> 5962-00B0218V9A <u>4/</u>	F7400	MG2M140E MG2M140E MM0-G2M140EHxxxMQ SM0-G2M140EHxxxSV
5962-00B0219Q_C <u>3/</u> 5962-00B0219V_C <u>3/</u> 5962-00B0219Q9A <u>4/</u> 5962-00B0219V9A <u>4/</u>	F7400	MG2M194E MG2M194E MM0-G2M194EHxxxMQ SM0-G2M194EHxxxSV
5962-00B0220Q_C <u>3/</u> 5962-00B0220V_C <u>3/</u> 5962-00B0220Q9A <u>4/</u> 5962-00B0220V9A <u>4/</u>	F7400	MG2M265E MG2M265E MM0-G2M265EHxxxMQ SM0-G2M265EHxxxSV
5962-00B0221Q_C <u>3/</u> 5962-00B0221V_C <u>3/</u> 5962-00B0221Q9A <u>4/</u> 5962-00B0221V9A <u>4/</u>	F7400	MG2M360E MG2M360E MM0-G2M360EHxxxMQ SM0-G2M360EHxxxSV

[查询"5962-00B02"供应商](#)

Standard microcircuit drawing PIN <u>1/</u>	Vendor CAGE number	Vendor similar PIN <u>2/</u>
5962-00B0222Q_C <u>3/</u> 5962-00B0222V_C <u>3/</u> 5962-00B0222Q9A <u>4/</u> 5962-00B0222V9A <u>4/</u>	F7400	MG2M480E MG2M480E MM0-G2M480EHxxxMQ SM0-G2M480EHxxxSV
5962-00B0223Q_C <u>3/</u> 5962-00B0223Q9A <u>4/</u>	F7400	MG2M044 MM0-G2M044xxxMQ
5962-00B0224Q_C <u>3/</u> 5962-00B0224Q9A <u>4/</u>	F7400	MG2M091 MM0-G2M091xxxMQ
5962-00B0225Q_C <u>3/</u> 5962-00B0225Q9A <u>4/</u>	F7400	MG2M140 MM0-G2M140xxxMQ
5962-00B0226Q_C <u>3/</u> 5962-00B0226Q9A <u>4/</u>	F7400	MG2M194 MM0-G2M194xxxMQ
5962-00B0227Q_C <u>3/</u> 5962-00B0227Q9A <u>4/</u>	F7400	MG2M265 MM0-G2M265xxxMQ
5962-00B0228Q_C <u>3/</u> 5962-00B0228Q9A <u>4/</u>	F7400	MG2M360 MM0-G2M360xxxMQ
5962-00B0229Q_C <u>3/</u> 5962-00B0229Q9A <u>4/</u>	F7400	MG2M480 MM0-G2M480xxxMQ

1/ The lead finish shown for each PIN representing a hermetic package is the most readily available from the manufacturer listed for that part. If the desired lead finish is not listed contact the vendor to determine its availability.

2/ Caution. Do not use this number for item acquisition. Items acquired to this number may not satisfy the performance requirements of this drawing.

3/ Due to the nature of this SMD, the standard microcircuit drawing PIN and corresponding vendor similar PIN shall be specified in the AID.

4/ The "xxx" is reserved to indicate the customer specific code.

Vendor CAGE
number

F7400

Vendor name
and address

Atmel Nantes S.A.
Part of Atmel Wireless & Microcontrollers
La Chanterie
BP 70602
44306 Nantes Cedex 03
France

The information contained herein is disseminated for convenience only and the Government assumes no liability whatsoever for any inaccuracies in the information bulletin.