

# NCP1605, NCP1605A

## Enhanced, High Voltage and Efficient Standby Mode, Power Factor Controller

The NCP1605 is a controller that exhibits near-unity power factor while operating in fixed frequency, Discontinuous Conduction Mode (DCM) or in Critical Conduction Mode (CRM).

Housed in a SOIC-16 package, the circuit incorporates all the features necessary for building robust and compact PFC stages, with a minimum of external components. In addition, it integrates the skip cycle capability to lower the standby losses to a minimum.

### General Features

- Near-Unity Power Factor
- Fixed Frequency, Discontinuous Conduction Mode Operation
- Critical Conduction Mode Achievable in Most Stressful Conditions
- Lossless High Voltage Current Source for Startup
- Soft Skip™ Cycle for Low Power Standby Mode
- Switching Frequency up to 250 kHz
- Synchronization Capability
- Fast Line / Load Transient Compensation
- Valley Turn On
- High Drive Capability: -500 mA / +800 mA
- Signal to Indicate that the PFC is Ready for Operation (“pfcOK” Pin)
- V<sub>CC</sub> range: from 10 V to 20 V
- Follower Boost Operation
- Two V<sub>CC</sub> Turn-On Threshold Options: 15 V for NCP1605, 10.5 V for NCP1605A
- This is a Pb-Free Device

### Safety Features

- Output Under and Overvoltage Protection
- Brown-Out Detection
- Soft-Start for Smooth Startup Operation
- Overcurrent Limitation
- Zero Current Detection Protecting the PFC stage from Inrush Currents
- Thermal Shutdown
- Latched Off Capability

### Typical Applications

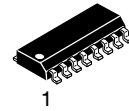
- PC Power Supplies
- All Off Line Appliances Requiring Power Factor Correction



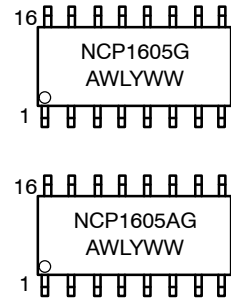
ON Semiconductor®

<http://onsemi.com>

### MARKING DIAGRAMS

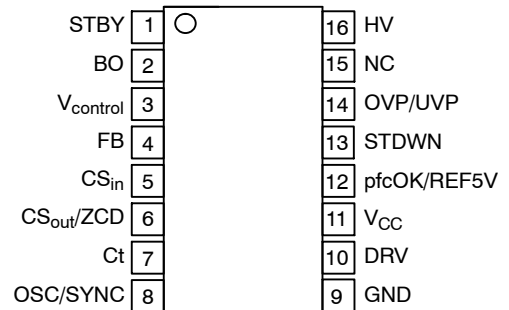


SOIC-16  
D SUFFIX  
CASE 751B



A = Assembly Location  
WL = Wafer Lot  
Y = Year  
WW = Work Week  
G = Pb-Free Package

### PIN CONNECTIONS



(Top View)

### ORDERING INFORMATION

Device	Package	Shipping†
NCP1605DR2G	SOIC-16 (Pb-Free)	2500/Tape & Reel
NCP1605ADR2G	SOIC-16 (Pb-Free)	2500/Tape & Reel

†For information on tape and reel specifications, including part orientation and tape sizes, please refer to our Tape and Reel Packaging Specification Brochure, BRD8011/D.

# NCP1605, NCP1605A

[查询"NCP1605DR2G"供应商](#)

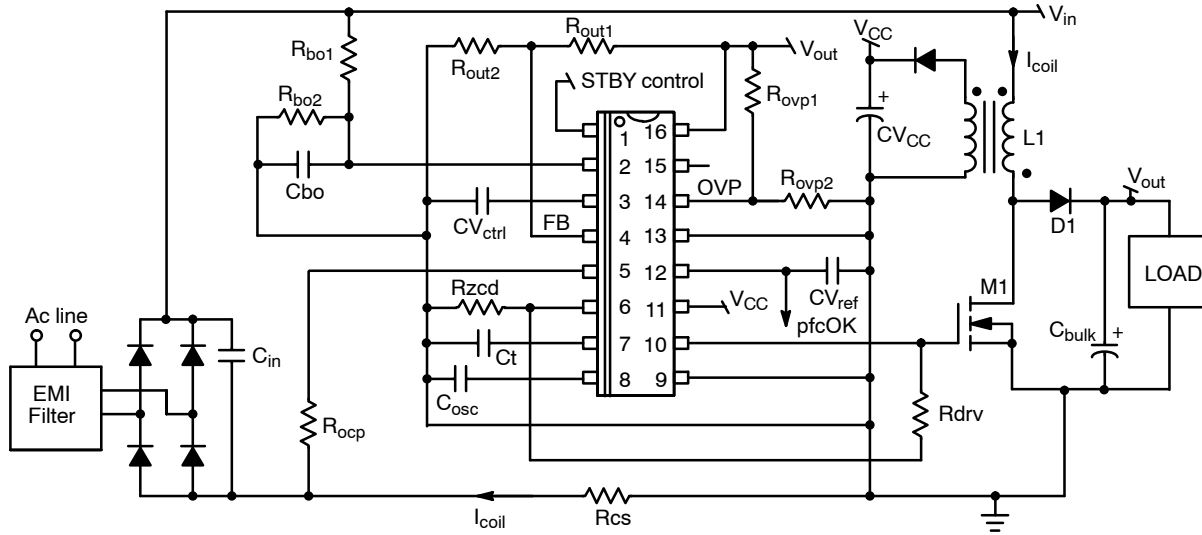


Figure 1.

## MAXIMUM RATINGS

Pin	Rating	Symbol	Value	Unit
10	Power Supply Input	$V_{CC}$	-0.3, +20	V
10	Maximum Transient Voltage (Note 1)	$V_{CC}$	-0.3, +25	V
1, 2, 4, 6, 7, 8, 13 and 14	Input Voltage	$V_I$	-0.3, +9	V
3	$V_{CONTROL}$ Pin	$V_{CONTROL}$	-0.3, $V_{CONTROL\ MAX}$ (Note 2)	V
16	High Voltage Pin	HV	-0.3, +500	V
	Power Dissipation and Thermal Characteristics: Maximum Power Dissipation @ $T_A = 70^\circ\text{C}$ Thermal Resistance Junction-to-Air	$P_D$ $R_{\theta JA}$	550 145	mW $^\circ\text{C/W}$
	Operating Junction Temperature Range	$T_J$	-40, +125	$^\circ\text{C}$
	Maximum Junction Temperature	$T_{Jmax}$	150	$^\circ\text{C}$
	Storage Temperature Range	$T_{Smax}$	-65 to 150	$^\circ\text{C}$
	Lead Temperature (Soldering, 10 s)	$T_{Lmax}$	300	$^\circ\text{C}$

Stresses exceeding Maximum Ratings may damage the device. Maximum Ratings are stress ratings only. Functional operation above the Recommended Operating Conditions is not implied. Extended exposure to stresses above the Recommended Operating Conditions may affect device reliability.

1. The maximum transient voltage with a corresponding maximum transient current at 100 mA. The maximum transient power handling capability must be observed as well.
2. " $V_{CONTROL\ MAX}$ " is the pin clamp voltage

# NCP1605, NCP1605A

## TYPICAL ELECTRICAL CHARACTERISTICS

(Conditions:  $V_{CC} = 16\text{ V}$ ,  $V_{HV} = 50\text{ V}$ ,  $V_{Pin2} = 2\text{ V}$ ,  $V_{Pin13} = 0\text{ V}$ ,  $T_J$  from  $0^\circ\text{C}$  to  $+125^\circ\text{C}$ , unless otherwise specified) (Note 2)

Symbol	Rating	Min	Typ	Max	Unit
--------	--------	-----	-----	-----	------

### Gate Drive Section

$T_{rise}$	Output Voltage Rise Time @ $C_L = 1\text{ nF}$ , from 1 V to 10 V	-	40	-	ns
$T_{fall}$	Output Voltage Fall Time @ $C_L = 1\text{ nF}$ , from 10 V to 1 V	-	20	-	ns
$R_{OH}$	Source Resistance @ $I_{Pin10} = 100\text{ mA}$	-	15	25	$\Omega$
$I_{source}$	Source Current capability (@ $V_{Pin10} = 0\text{ V}$ )	-	500	-	mA
$R_{OL}$	Sink Resistance @ $I_{Pin10} = 100\text{ mA}$	-	7	15	$\Omega$
$I_{sink}$	Sink Current Capability (@ $V_{Pin10} = 10\text{ V}$ )	-	800	-	mA

### Regulation Block

$V_{REF}$	Voltage Reference	2.425	2.500	2.575	V
$I_{EA}$	Error Amplifier Current Capability	-	$\pm 20$	-	$\mu\text{A}$
$G_{EA}$	Error Amplifier Gain	100	200	300	$\mu\text{S}$
$I_{BPin4}$	Pin 4 Bias Current @ $V_{Pin4} = V_{REF}$	-500	-	500	nA
$V_{CONTROL}$ - $V_{CONTROLMAX}$ - $V_{CONTROLMIN}$ - $\Delta V_{CONTROL}$	Pin 2 Voltage:  - @ $V_{Pin4} = 2\text{ V}$ - @ $V_{Pin4} = 3\text{ V}$	- - 2.7	3.6 0.6 3.0	- - 3.3	V
$V_{OUTL} / V_{REF}$	Ratio ( $V_{OUT}$ Low Detect Threshold / $V_{REF}$ ) (Note 4)	95.0	95.5	96.0	%
$H_{OUTL} / V_{REF}$	Ratio ( $V_{OUT}$ Low Detect Hysteresis / $V_{REF}$ ) (Note 4)	-	-	0.5	%
$I_{BOOST}$	Pin 2 Source Current when ( $V_{OUT}$ Low Detect) is activated	190	240	290	$\mu\text{A}$

### Shutdown Block

$I_{LEAKAGE}$	Current Sourced by Pin 13 @ $V_{Pin14} = 2.3\text{ V}$	-500	-	500	nA
$V_{STDWN}$	Pin 13 Threshold for Shutdown	2.375	2.500	2.625	V

### Over and Under Voltage Protections

$V_{OVP}$	Overvoltage Protection Threshold	2.425	2.500	2.575	V
$V_{OVP} / V_{REF}$	Ratio ( $V_{OVP} / V_{REF}$ ) (Note 3)	99.5	100.0	100.5	%
$V_{UVP} / V_{REF}$	Ratio UVP threshold over $V_{REF}$	8	12	16	%
$I_{BPin14}$	Pin 13 Bias Current:  @ $V_{Pin14} = V_{OVP}$ @ $V_{Pin14} = V_{UVP}$	-500 -500	- -	500 500	nA

### Ramp Control

$I_{RAMP - 1.00\text{ V}}$ $I_{RAMP - 1.75\text{ V}}$ $I_{RAMP - 2.50\text{ V}}$	Pin 7 Source Current:  @ $V_{Pin4} = 1.00\text{ V}$ @ $V_{Pin4} = 1.75\text{ V}$ @ $V_{Pin4} = 2.50\text{ V}$	54 156 313	60 182 370	69 214 428	$\mu\text{A}$
$V_{cl\_ff}$	Pin 7 Clamp Voltage @ $V_{Pin4} = V_{Pin2} = 2\text{ V}$ and $V_{Pin6} = 0\text{ V}$	-	5	-	V
$V_{CLCRM}$	Pin 7 Clamp Voltage @ $V_{Pin4} = 0\text{ V}$ , $V_{Pin2} = 2\text{ V}$ and $V_{Pin6} = 1\text{ V}$	0.9	1	1.1	V
$R_{CT}$	Ratio (Pin 7 Clamp Voltage / (Pin 7 Charge Current) ( $V_{CLCRM} / I_{RAMP}$ ) @ $V_{Pin6} = 0\text{ V}$ and  - $V_{Pin4} = 1.00\text{ V}$ - $V_{Pin4} = 1.75\text{ V}$ - $V_{Pin4} = 2.50\text{ V}$	- - -	16.7 5.4 2.7	- - -	k $\Omega$
$T_{ONMIN}$	Delay ( $V_{Pin7} > 5\text{ V}$ ) to (DRV low)	-	90	200	ns

3. Not tested; guaranteed by characterization

4. Not tested; guaranteed by design

# NCP1605, NCP1605A

## TYPICAL ELECTRICAL CHARACTERISTICS

(Conditions:  $V_{CC} = 16\text{ V}$ ,  $V_{HV} = 50\text{ V}$ ,  $V_{Pin2} = 2\text{ V}$ ,  $V_{Pin13} = 0\text{ V}$ ,  $T_J$  from  $0^\circ\text{C}$  to  $+125^\circ\text{C}$ , unless otherwise specified) (Note 2)

Symbol	Rating	Min	Typ	Max	Unit
$C_{INT}$	Average Pin 7 Internal Capacitance ( $V_{Pin7}$ varying from 0 and 1 V) Guaranteed by design	-	15	25	pF
$V_{INIT}$	Maximum Pin 7 Voltage Allowing the Setting of the PWM Latch	-	50	90	mV
$I_{RAMP\_SINK}$	Pin 7 Sink Current (Drive low) @ $V_{Pin7} = 1\text{ V}$	-	10	-	mA

### Current Sense Block

Off100	Current Sense Pin Voltage, 100 $\mu\text{A}$ being drawn from Pin 5	-20	0	20	mV
Off10	Current Sense Pin Voltage, 10 $\mu\text{A}$ being drawn from Pin 5	3.0	8.0	13	mV
$I_{MAX}$	Overcurrent Protection Threshold	230	250	265	$\mu\text{A}$
$T_{OCP}$	( $I_{Pin5} > 250\text{ }\mu\text{A}$ ) to (DRV low) Propagation Delay (Note 3)	-	100	200	ns
$K_{CS10}$	Ratio ( $I_{Pin6}/I_{Pin5}$ ) @ $I_{Pin5} = 10\text{ }\mu\text{A}$	99	108	117	%
$K_{CS200}$	Ratio ( $I_{Pin6}/I_{Pin5}$ ) @ $I_{Pin5} = 200\text{ }\mu\text{A}$	98	101	103	%
$V_{ZCD}$	Pin 6 Comparator Threshold	50	100	200	mV
$T_{ZCD}$	Delay from ( $V_{Pin6} < V_{ZCD}$ ) to (DRV high)	-	120	240	ns

### Standby Input

$V_{STBY}$	Standby Mode Threshold ( $V_{Pin1}$ falling)	280	310	340	mV
$H_{STBY}$	Hysteresis for Standby Mode Detection	25	30	50	mV
$V_{SKIPOUT} / V_{OUTL}$	Ratio (Pin 4 Voltage to terminate a SKIP period) over the ( $V_{OUT}$ Low Detect Threshold) (Note 4)	99	100	101	%

### Oscillator / Synchronization Block

$I_{charge}$	Oscillator Charge Current	90	100	110	$\mu\text{A}$
$I_{disch}$	Oscillator Discharge Current	90	100	110	$\mu\text{A}$
$V_{sync\_H}$	Comparator Upper Threshold	-	3.0	-	V
$V_{sync\_L}$	Comparator Lower Threshold	-	2.0	-	V
Swing	Comparator Swing ( $V_{sync\_H} - V_{sync\_L}$ )	0.9	1.0	1.1	V
$T_{sync\_min}$	Minimum Synchronization Pulse Width for Detection	-	-	500	ns

### pfcOK / REF5V

$V_{pfcOKL}$	Pin 12 Voltage @ $V_{Pin13} = 5\text{ V}$ , 250 $\mu\text{A}$ being sunk by Pin 12	-	60	120	mV
$V_{pfcOKH}$	Pin 12 Voltage @ $V_{Pin13} = 0\text{ V}$ and $V_{Pin3} = 5\text{ V}$ , with a 250 $\mu\text{A}$ sourced by Pin 12	4.7	5.0	5.3	V
	Pin 12 Voltage @ $V_{Pin13} = 0\text{ V}$ and $V_{Pin3} = 5\text{ V}$ , with a 5 mA sourced by Pin 12	4.5	5.0	5.3	V
$I_{cap\_ref}$	Current Capability	5.0	10	-	mA

### Brown-Out Detection Block

$V_{BOH}$	Brown-Out Comparator Threshold ( $V_{Pin2}$ rising)	0.9	1.0	1.1	V
$V_{BOL}$	Brown-Out Comparator Threshold ( $V_{Pin2}$ falling)	0.45	0.50	0.55	V
$I_{BBO}$	Pin 2 Bias Current @ $V_{Pin2} = 0.5\text{ V}$ and 1 V	-500	-	500	nA

### Thermal Shutdown

$T_{LIMIT}$	Thermal Shutdown Threshold	-	155	-	$^\circ\text{C}$
$H_{TEMP}$	Thermal Shutdown Hysteresis	-	15	-	$^\circ\text{C}$

### $V_{CC}$ UNDERVOLTAGE Lockout Section

$V_{CCON}$	Turn on Threshold Level, $V_{CC}$ Raising Up	NCP1605 NCP1605A	14 9.5	15 10.5	16 11.5	V
------------	--	---------------------	-----------	------------	------------	---

- Not tested; guaranteed by characterization
- Not tested; guaranteed by design

# NCP1605, NCP1605A

## TYPICAL ELECTRICAL CHARACTERISTICS

(Conditions:  $V_{CC} = 16\text{ V}$ ,  $V_{HV} = 50\text{ V}$ ,  $V_{Pin2} = 2\text{ V}$ ,  $V_{Pin13} = 0\text{ V}$ ,  $T_J$  from  $0^\circ\text{C}$  to  $+125^\circ\text{C}$ , unless otherwise specified) (Note 2)

Symbol	Rating	Min	Typ	Max	Unit
$V_{CCOFF}$	Minimum Operating Voltage after Turn-on	8.0	9.0	10	V
$H_{UVLO}$	Difference ( $V_{CCON} - V_{CCOFF}$ )	NCP1605 1.2	6.0 1.5	- -	V
$V_{CCSTUP}$	$V_{CC}$ Threshold below which the Startup Current Source Turns on	5.5	7.0	8.0	V
$H_{LATCHOFF}$	Difference ( $V_{CCOFF} - V_{CCSTUP}$ )	0.6	2.0	-	V
$V_{CCRST}$	$V_{CC}$ Level at which the Logic Resets	2.0	4.0	5.0	V

### Internal STARTUP Current Source

IC1_hv	High-Voltage Current Source (sunk by Pin 16), $V_{CC} = 13.5\text{ V}$	5	12	20	mA
IC1_Vcc	Startup Charge Current flowing out of the $V_{CC}$ Pin, $V_{CC} = 13.5\text{ V}$	5	12	20	mA
IC2	High-Voltage Current Source, $V_{CC} = 0\text{ V}$	-	0.5	1.0	mA

### Device Consumption

	Power Supply Current:				
$I_{cc\_op1}$	Operating (@ $V_{CC} = 16\text{ V}$ , no load, no switching)	-	2.5	5	mA
$I_{cc\_op2}$	Operating (@ $V_{CC} = 16\text{ V}$ , no load, switching)	2.0	3.5	7	mA
$I_{cc\_OFF}$	Off Mode (@ $V_{CC} = 16\text{ V}$ , Pin 2 grounded)	310	570	780	$\mu\text{A}$
$I_{cc\_latchOFF}$	Latched-Off Mode (@ $V_{CC} = 13.5\text{ V}$ and $V_{Pin13} = 5\text{ V}$ )	310	550	750	$\mu\text{A}$

- Not tested; guaranteed by characterization
- Not tested; guaranteed by design

## NCP1605, NCP1605A

### PIN FUNCTION DESCRIPTION

Pin Number	Name	Function
1	STBY	An external signal (typically, a portion of the feedback signal of the downstream converter or a filtered portion of the SMPS drive pulses) should be applied to Pin 1. When the Pin 3 voltage goes below 300 mV, the circuit enters a burst mode operation where the bulk voltage varies between the regulation voltage and 95.5% of this level.
2	Brown-Out / Inhibition	Apply a portion of the averaged input voltage to detect brown-out conditions. If $V_{Pin2}$ is lower than 0.5 V, the circuit stops pulsing until $V_{Pin2}$ exceeds 1 V (0.5 V hysteresis). Ground Pin 6 to disable the part.
3	$V_{CONTROL}$ / Soft-Start	The error amplifier output is available on this Pin. The capacitor connected between this pin and ground adjusts the regulation loop bandwidth that is typically set below 20 Hz to achieve high Power Factor ratios. Pin 3 is grounded when the circuit is off so that when it starts operation, the power increases slowly (soft-start).
4	Feedback	This pin receives a portion of the pre-converter output voltage. This information is used for the regulation and the "output low" detection ( $V_{OUTL}$ ) that drastically speed up the loop response when the output voltage drops below 95.5% of the wished level.
5	Current Sense Input	This pin monitors a negative voltage proportional to the coil current. This signal is sensed to limit the maximum coil current and detect the core reset (coil demagnetization).
6	Current Sense Output	This pin sources the Pin 5 current. Place a resistor between Pin 6 and ground to build the voltage proportional to the coil current and detect the core reset. The impedance between Pin 6 and ground should not exceed 3 times that of the Pin 5 to ground. You can further apply the voltage from an auxiliary winding to improve the valley detection of the MOSFET drain source voltage.
7	Ct (Ramp)	The circuit controls the power switch on-time by comparing the Pin 7 ramp to an internal voltage (" $V_{ton}$ " derived from the regulation block and the sensed "dcycle" (relative duration of the current cycle over the corresponding switching period). Pin 7 sources a current proportional to the squared output voltage to allow the Follower Boost operation (optional) where the PFC output voltage stabilizes at a level that varies linearly versus the ac line amplitude. This technique reduces the difference between the output and input voltages, to optimize the boost efficiency and minimize the size and cost of the PFC stage
8	Oscillator / synchronization	Connect a capacitor or apply a synchronization signal to this pin to set the switching frequency. If the coil current cycle is longer than the selected switching period, the circuit delays the next cycle until the core is reset. Hence, the PFC stage can operate in CRM in the most stressful conditions.
9	GND	Connect this pin to the pre-converter ground.
10	Drive	The high current capability of the totem pole gate drive (+0.5/-0.8 A) makes it suitable to effectively drive high gate charge power MOSFETs.
11	$V_{CC}$	This pin is the positive supply of the IC. The circuit starts to operate when $V_{CC}$ exceeds 15 V (10.5 V for NCP1605A) and turns off when $V_{CC}$ goes below 9 V (typical values). After startup, the operating range is 10 V up to 20 V.
12	PfcOK / REF5V	The Pin 12 voltage is high (5 V) when the PFC stage is in a normal, steady state situation and low otherwise. This signal serves to "inform" the downstream converter that the PFC stage is ready and that hence, it can start operation.
13	STDWN	Apply a voltage higher than 2.5 V on Pin 13 to permanently shutdown the circuit. This pin can be used to monitor the voltage across a thermistor in order to protect the application from an excessive heating and/or to detect an overvoltage condition. To resume operation, it is necessary to decrease the circuit $V_{CC}$ below $V_{CCRST}$ (4 V typically) by for instance, unplugging the PFC stage and replugging it after $V_{CC}$ is discharged.
14	OVP / UVP	The circuit turns off when $V_{Pin14}$ goes below 480 mV (UVP) and disables the drive as long as the pin voltage exceeds 2.5 V (OVP).
15	NC	Creepage distance.
16	HV	Connect Pin 16 to the bulk capacitor. The internal startup current source placed between Pin 16 and the $V_{CC}$ terminal, charges the $V_{CC}$ capacitor at startup.

# NCP1605, NCP1605A

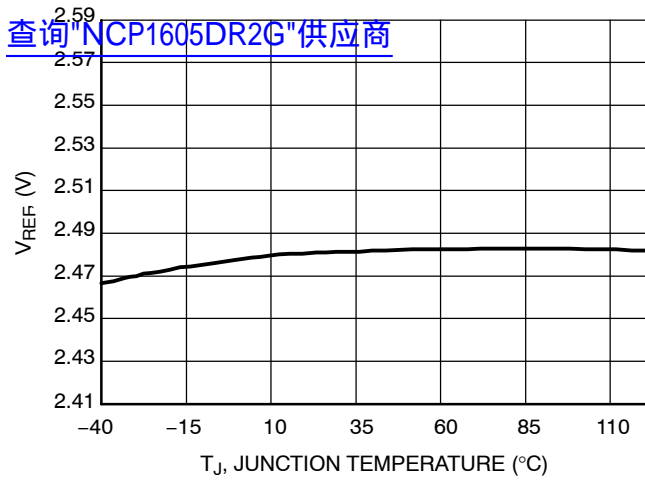


Figure 2. Reference Voltage vs. Temperature

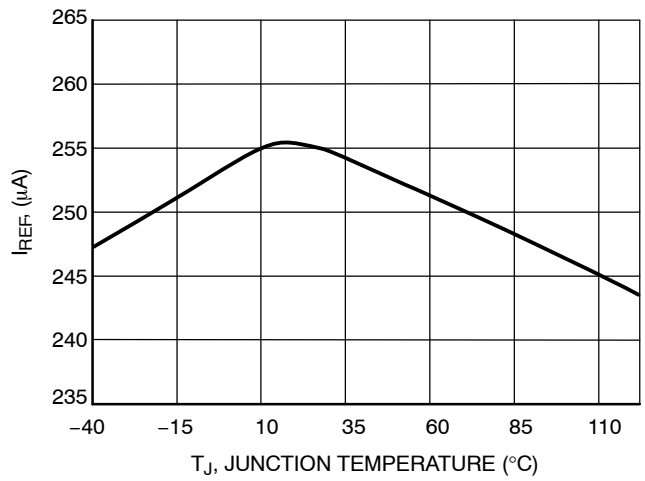


Figure 3. Reference Current vs. Temperature

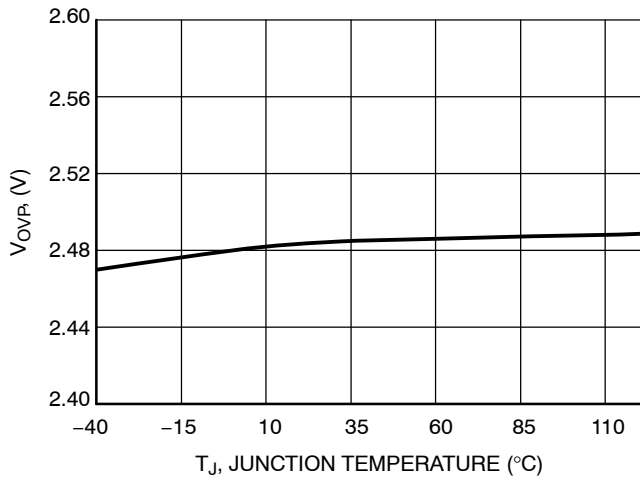


Figure 4. Overvoltage Threshold vs. Temperature

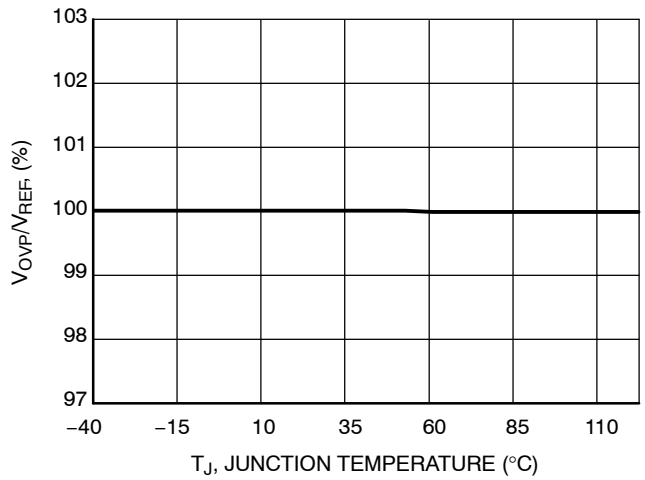


Figure 5. Ratio Overvoltage Threshold Overvoltage Reference vs. Temperature

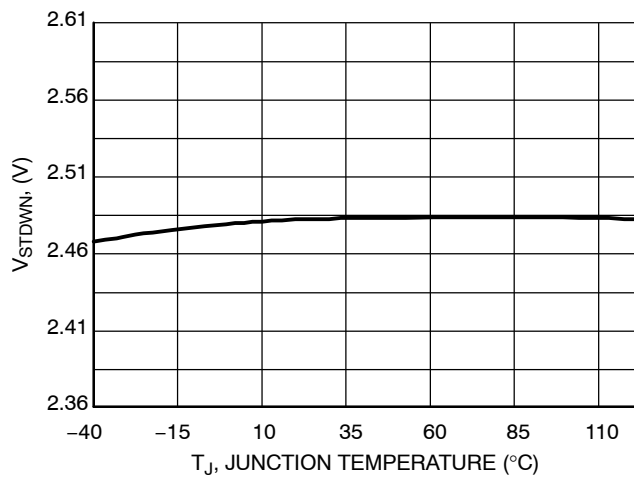
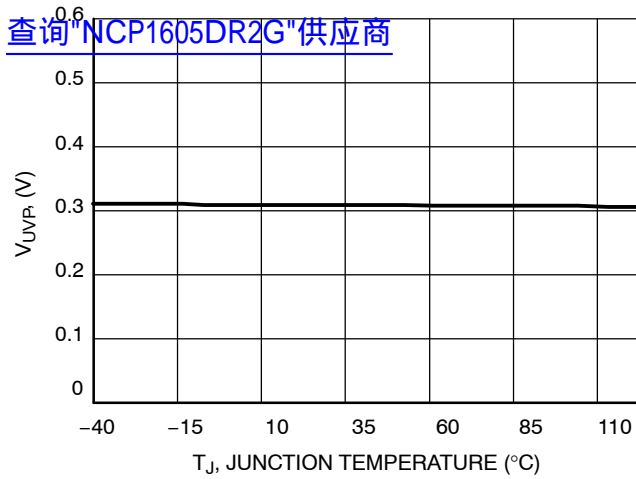
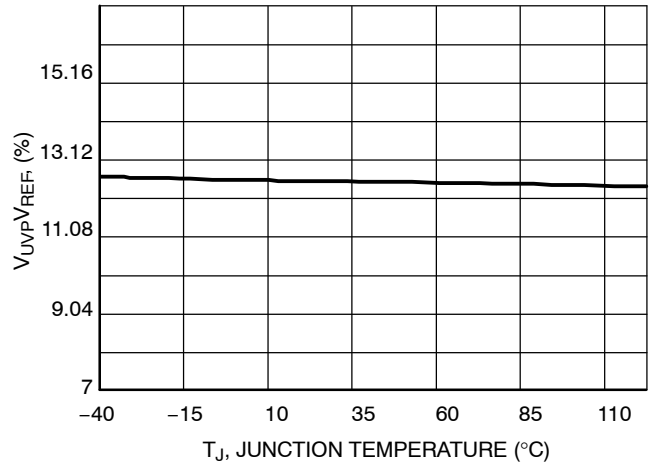


Figure 6. Shutdown Threshold vs. Temperature

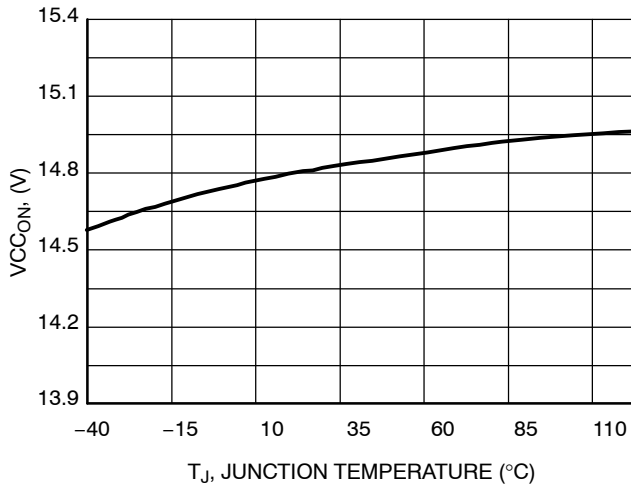
# NCP1605, NCP1605A



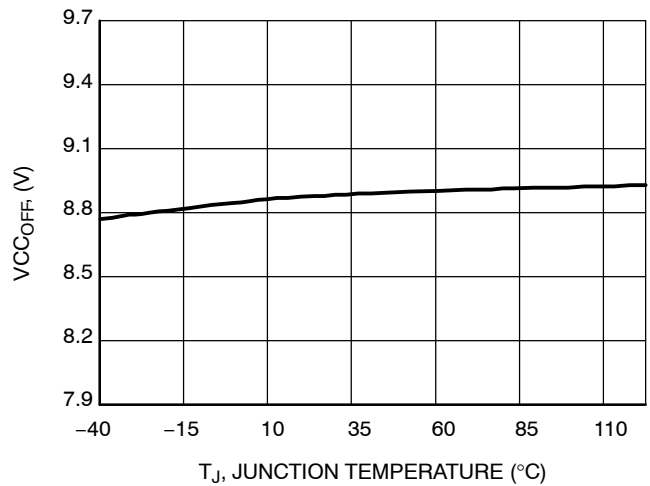
**Figure 7. Undervoltage Protection Threshold vs. Temperature**



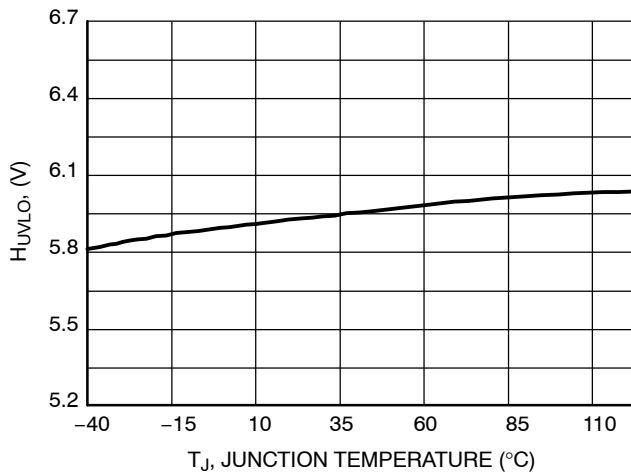
**Figure 8. Ratio (V<sub>UVP</sub>/V<sub>REF</sub>) vs. Temperature**



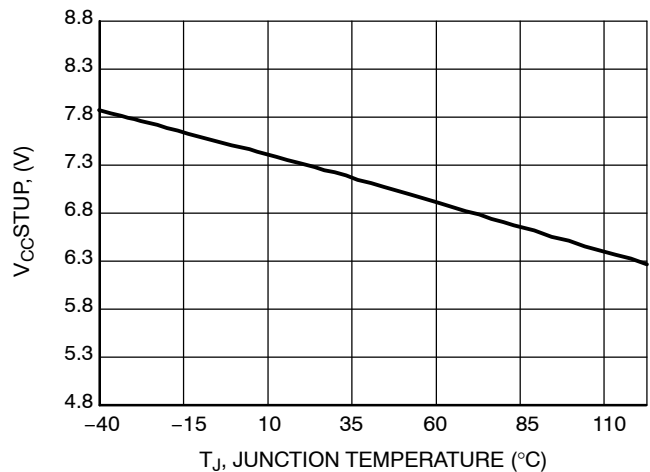
**Figure 9. V<sub>CC</sub> Turn on Threshold vs. Temperature (V<sub>CC</sub> Raising Up) - NCP1605**



**Figure 10. V<sub>CC</sub> Minimum Operating Voltage After Turn On**



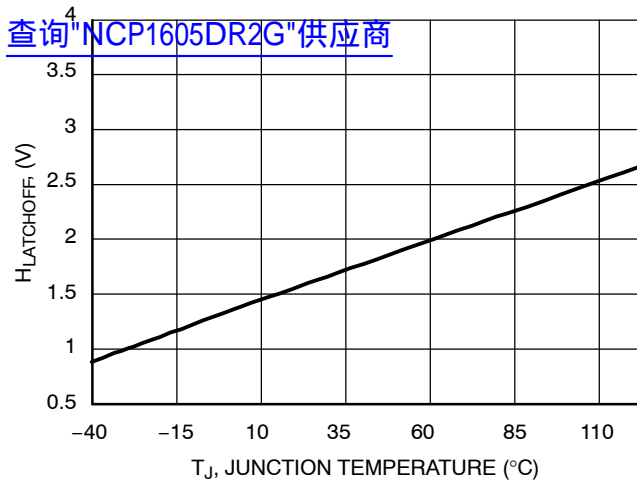
**Figure 11. Difference (V<sub>CC\_ON</sub> - V<sub>CC\_OFF</sub>) vs. Temperature**



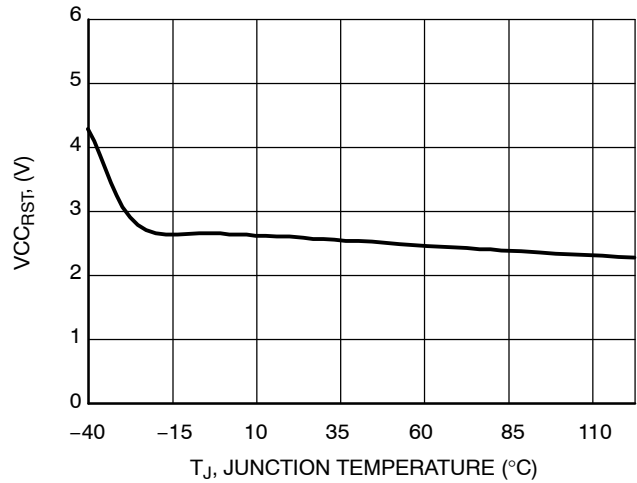
**Figure 12. V<sub>CC</sub> Threshold Below which the Startup Current Source Turns on vs. Temperature**



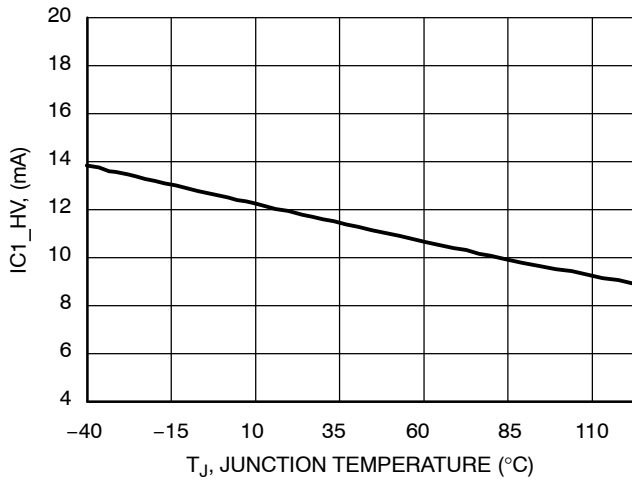
# NCP1605, NCP1605A



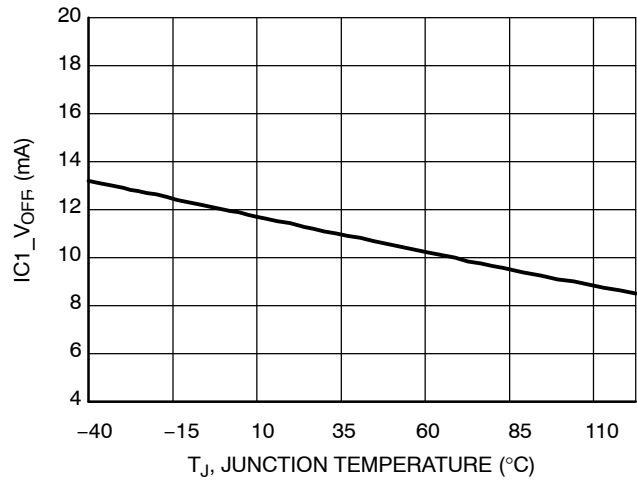
**Figure 13. Difference ( $V_{CCOFF} - V_{CCSTUP}$ ) vs. Temperature**



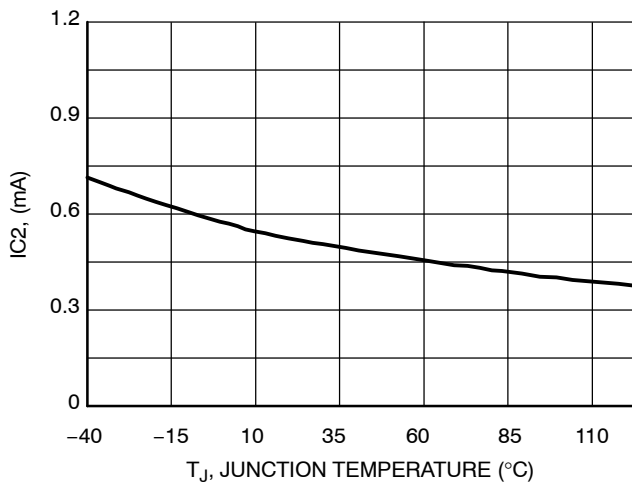
**Figure 14.  $V_{CC}$  Level Below Which the Logic Resets vs. Temperature**



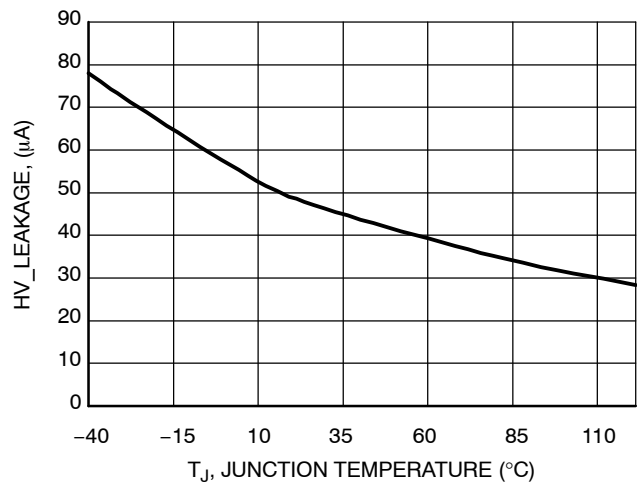
**Figure 15. High-Voltage Current Source (Sunk by Pin 16) vs. Temperature (@  $V_{CC} = 13.5$  V)**



**Figure 16. Startup Charge Current Flowing Out of the  $V_{CC}$  Pin vs. Temperature (@  $V_{CC} = 13.5$  V)**

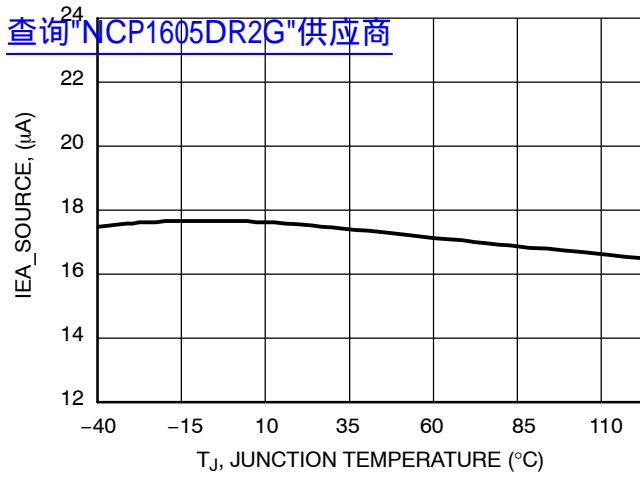


**Figure 17. High-Voltage Current Source vs. Temperature (@  $V_{CC} = 0$  V)**

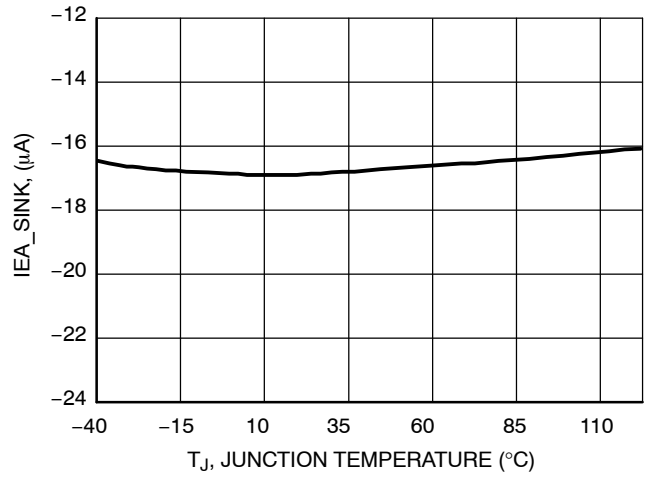


**Figure 18. Pin 16 Leakage Current vs. Temperature (@  $V_{PIN16} = 500$  V and  $V_{CC} = 16$  V)**

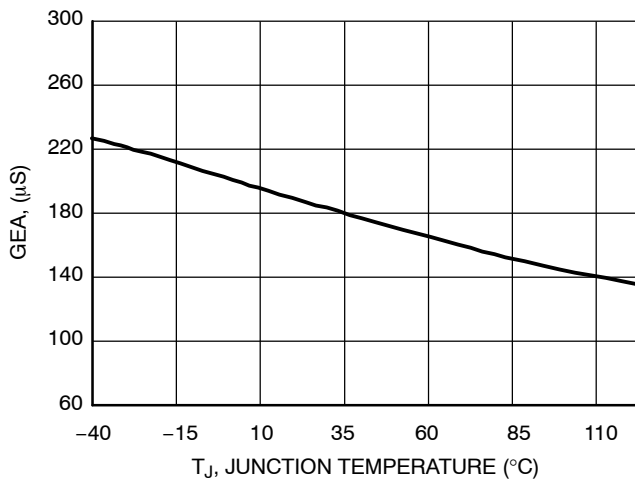
# NCP1605, NCP1605A



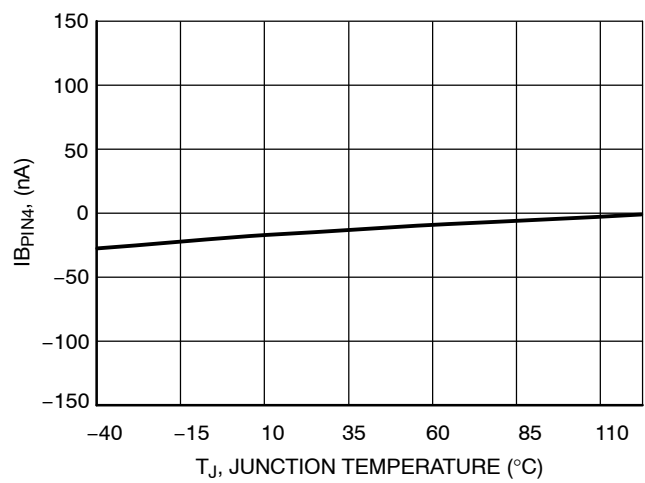
**Figure 19. Source Current Capability of the Error Amplifier vs. Temperature**



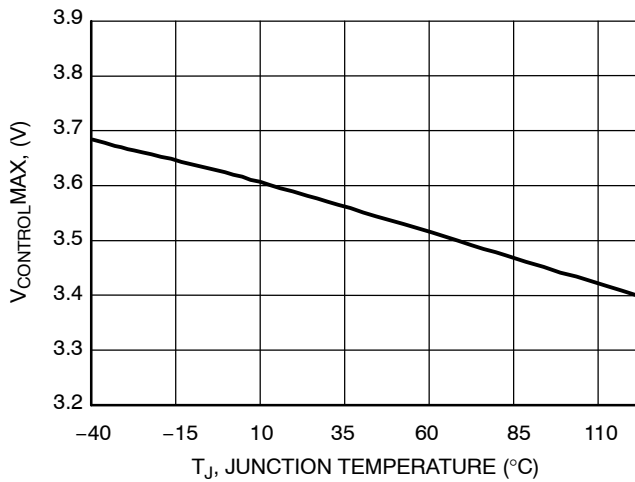
**Figure 20. Sink Current Capability of the Error Amplifier vs. Temperature**



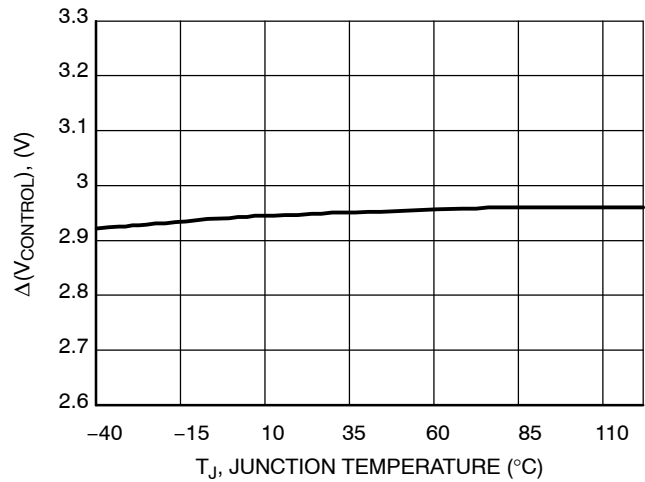
**Figure 21. Error Amplifier Gain vs. Temperature**



**Figure 22. Feedback Pin Bias Current vs. Temperature (@ V<sub>pin4</sub> = V<sub>REF</sub>)**

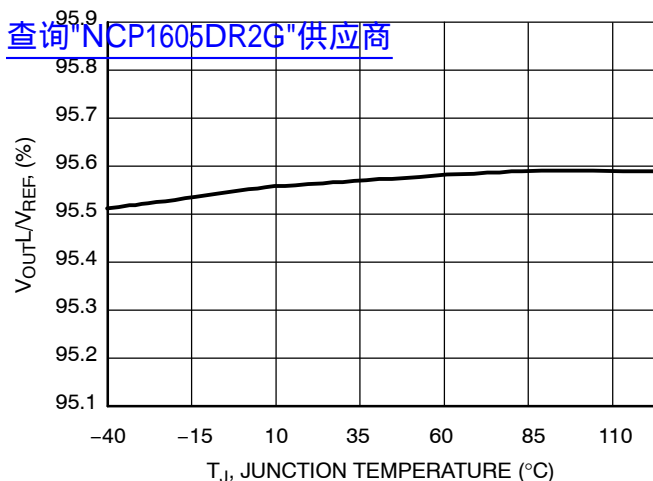


**Figure 23. V<sub>CONTROL</sub> Maximum Voltage vs. Temperature**

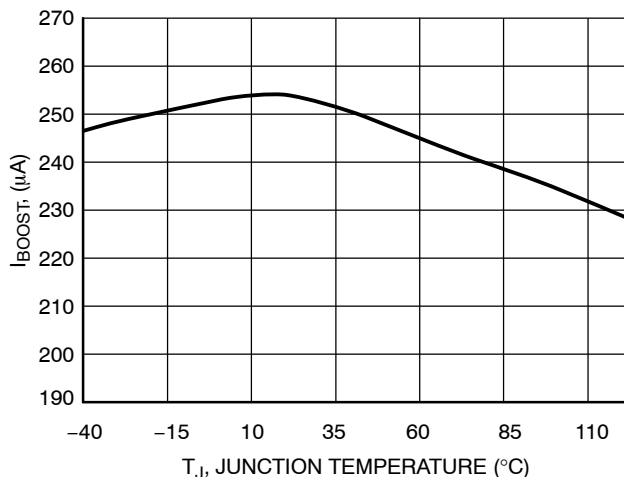


**Figure 24. V<sub>CONTROL</sub> Maximum Swing (ΔV<sub>CONTROL</sub>) vs. Temperature**

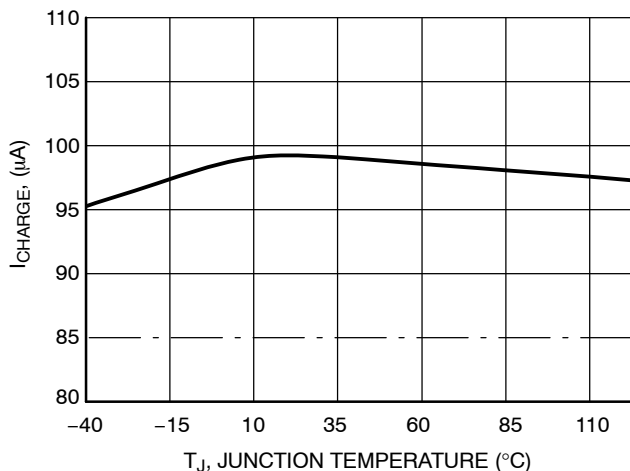
# NCP1605, NCP1605A



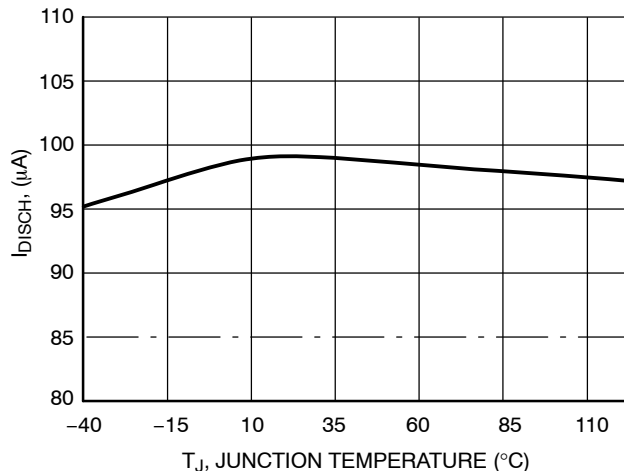
**Figure 25. Ratio (V<sub>OUT</sub> Low Detect Threshold) / V<sub>REF</sub> vs. Temperature**



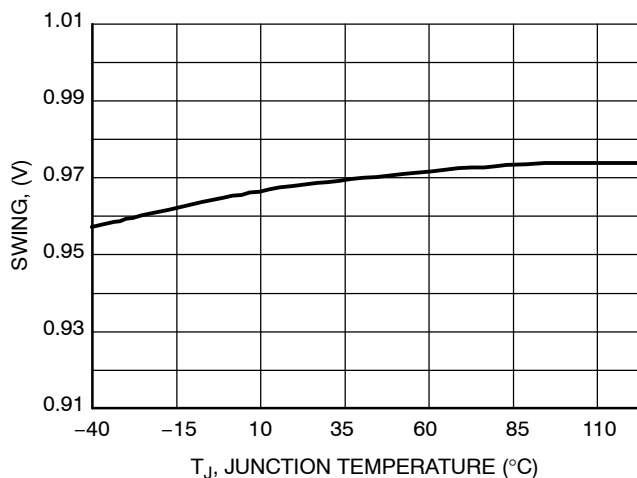
**Figure 26. Pin 3 Source Current when (V<sub>OUT</sub> Low Detect Threshold) is Activated vs. Temperature**



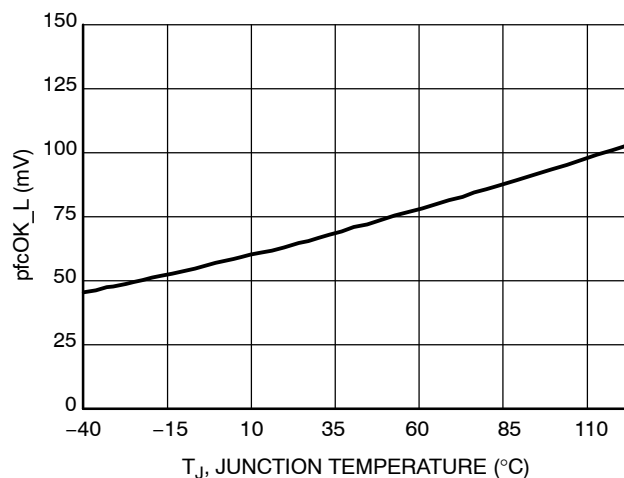
**Figure 27. Oscillator Charge Current vs. Temperature**



**Figure 28. Oscillator Discharge Current vs. Temperature**

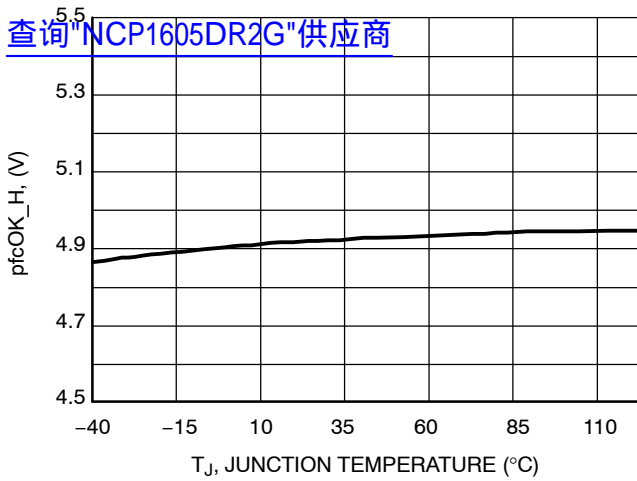


**Figure 29. Oscillator Swing vs. Temperature**

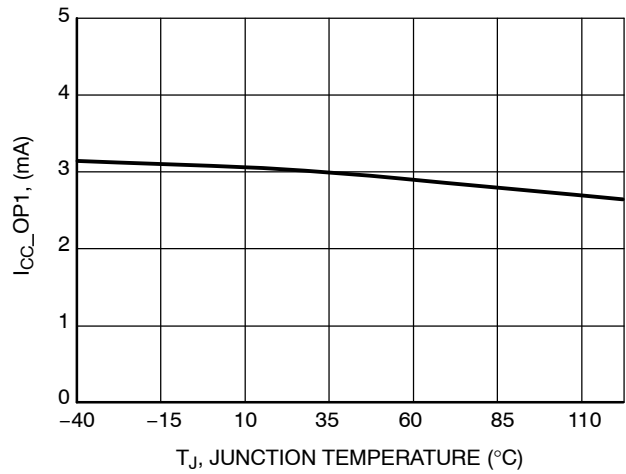


**Figure 30. pfcOK Pin Low Level Voltage vs. Temperature**

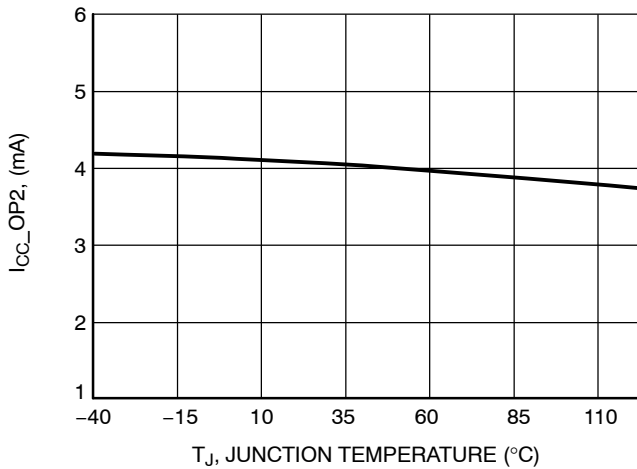
# NCP1605, NCP1605A



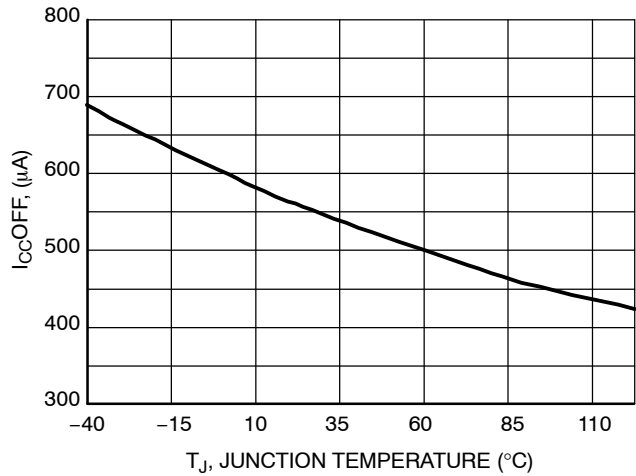
**Figure 31. pfcOK Pin High Level Voltage vs. Temperature (250  $\mu$ A Load)**



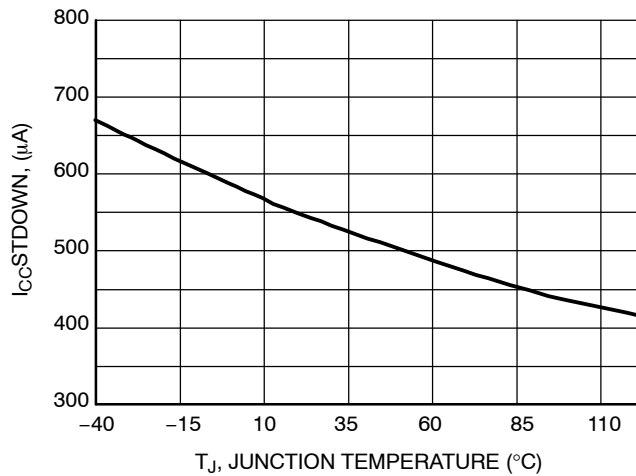
**Figure 32. Operating Consumption vs. Temperature ( $V_{CC} = 16$  V, No Load, No Switching)**



**Figure 33. Operating Consumption vs. Temperature ( $V_{CC} = 16$  V, No Load, Switching)**

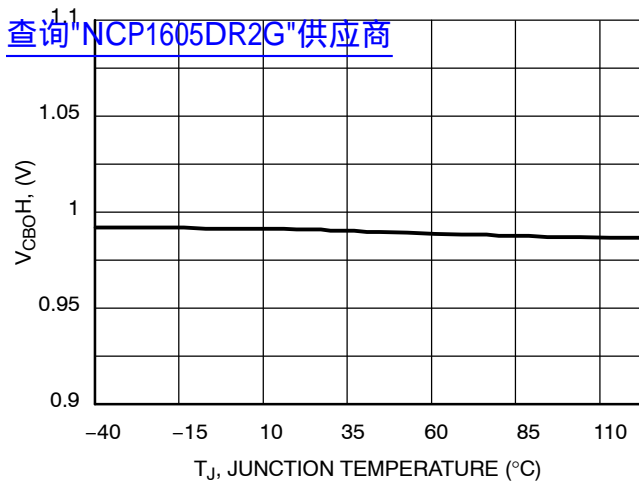


**Figure 34. Off Mode Consumption vs. Temperature ( $V_{CC} = 16$  V, Pin 2 Grounded)**

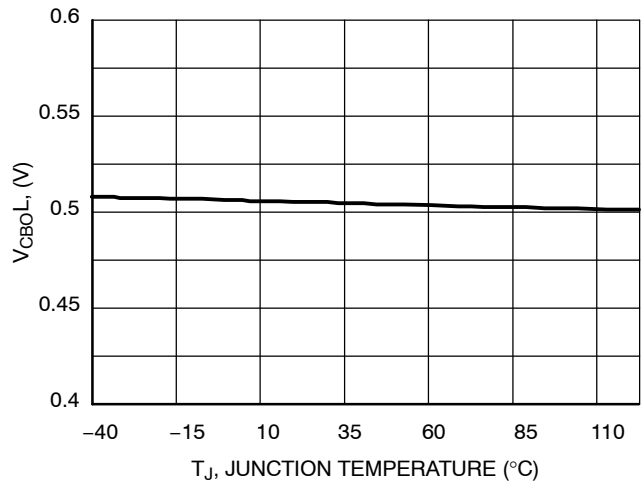


**Figure 35. Shutdown Mode Consumption vs. Temperature ( $V_{CC} = 16$  V, Pin 2 GND)**

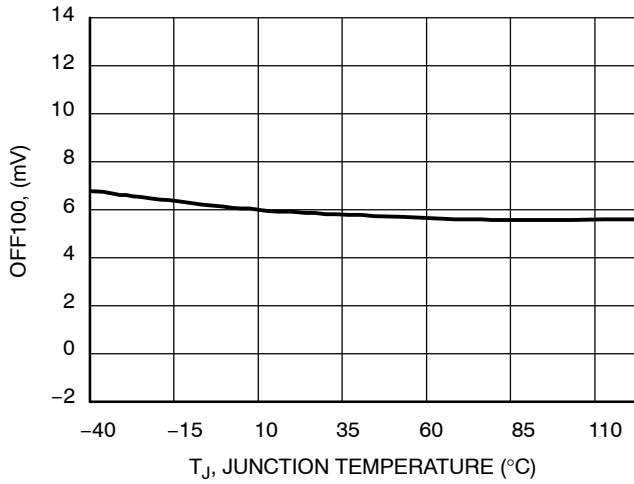
# NCP1605, NCP1605A



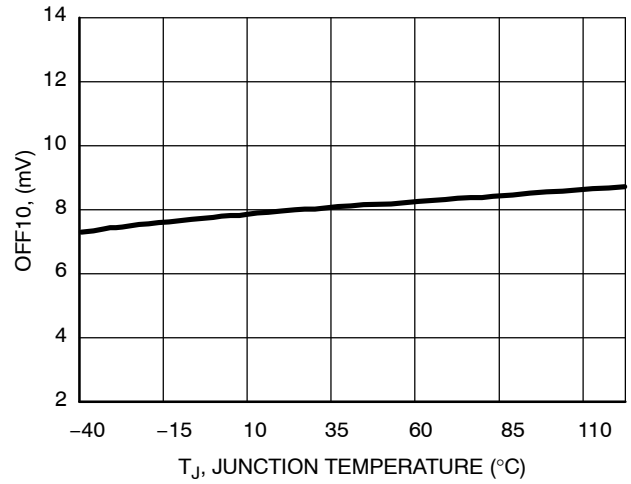
**Figure 36. Brown-Out Upper Threshold vs. Temperature**



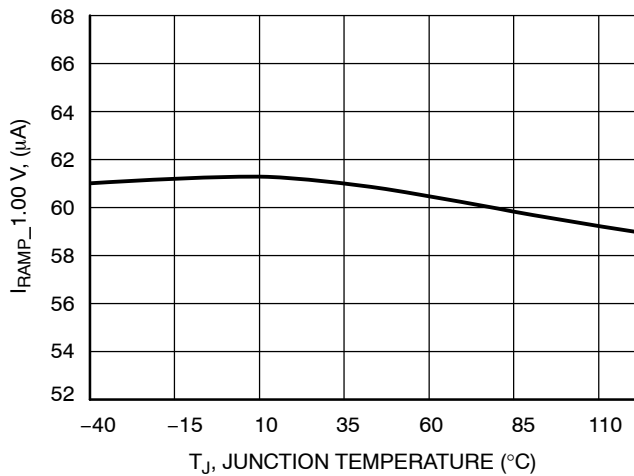
**Figure 37. Brown-Out Lower Threshold vs. Temperature**



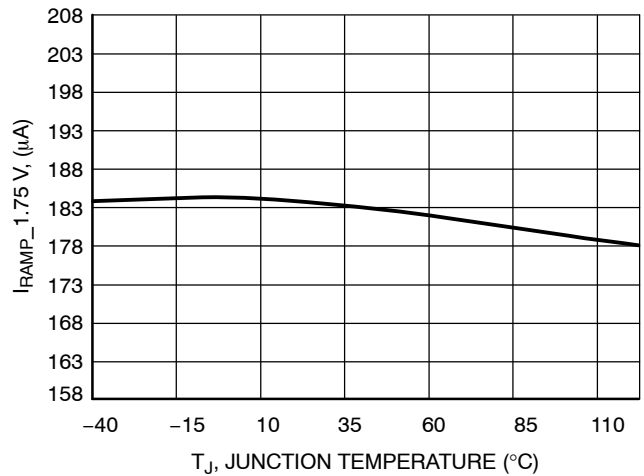
**Figure 38. Current Sense Pin Voltage vs. Temperature (100 μA Being Drawn from Pin 5)**



**Figure 39. Current Sense Pin Voltage vs. Temperature (10 μA Being Drawn from Pin 5)**

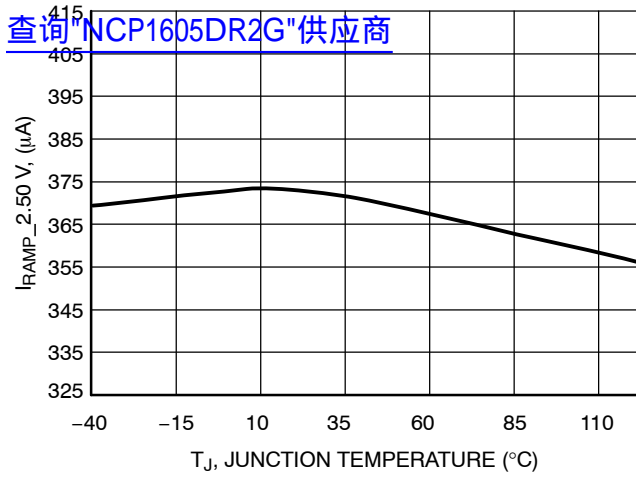


**Figure 40. Pin 7 Source Current @ V<sub>PIN4</sub> = 1.0 V vs. Temperature**

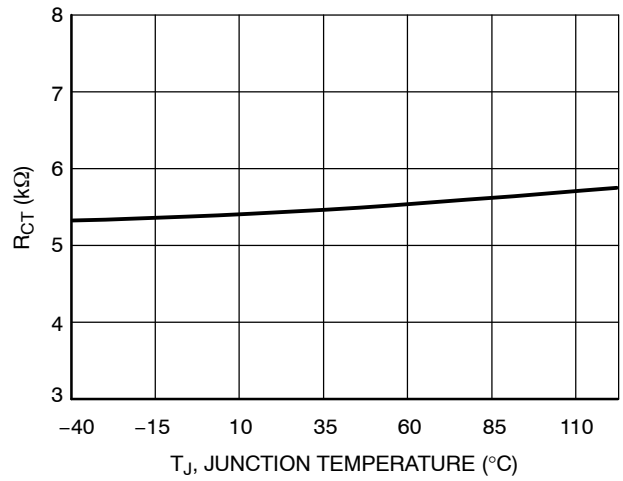


**Figure 41. Pin 7 Source Current @ V<sub>PIN4</sub> = 1.75 V vs. Temperature**

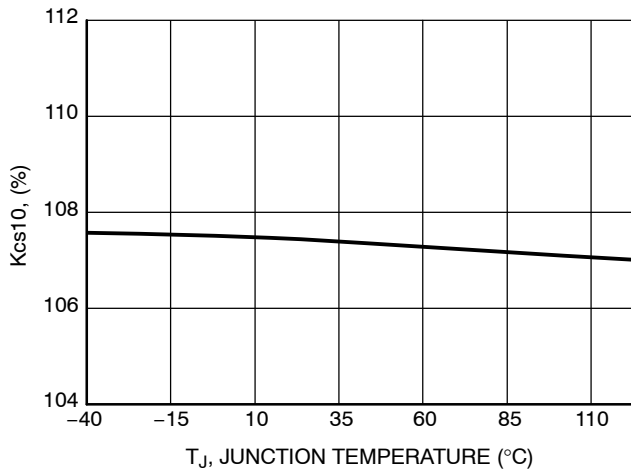
# NCP1605, NCP1605A



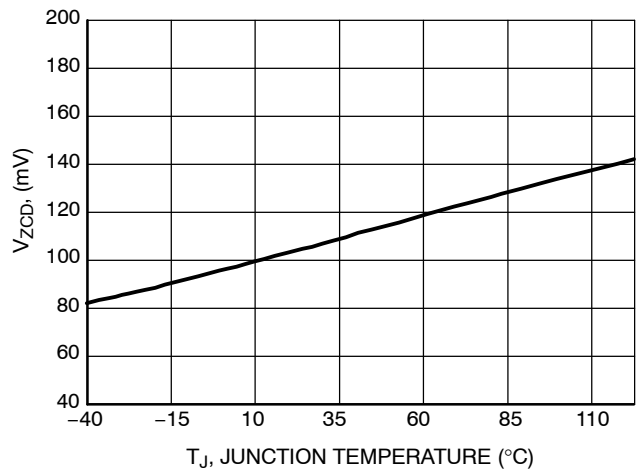
**Figure 42. Pin 7 Source Current @ V<sub>PIN4</sub> = 2.5 V vs. Temperature**



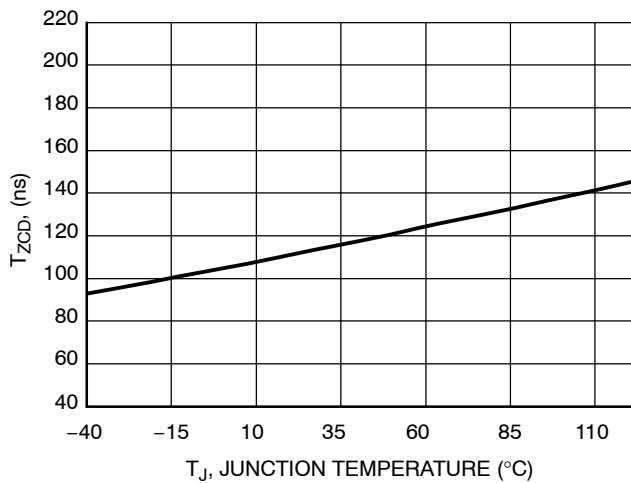
**Figure 43. Ratio Pin 7 Clamp Voltage / (Pin 7 Charge Current) that is (V<sub>CLCRM</sub> / I<sub>RAMP</sub>) @ V<sub>PIN6</sub> = 0 V and V<sub>PIN4</sub> = 1.75 V**



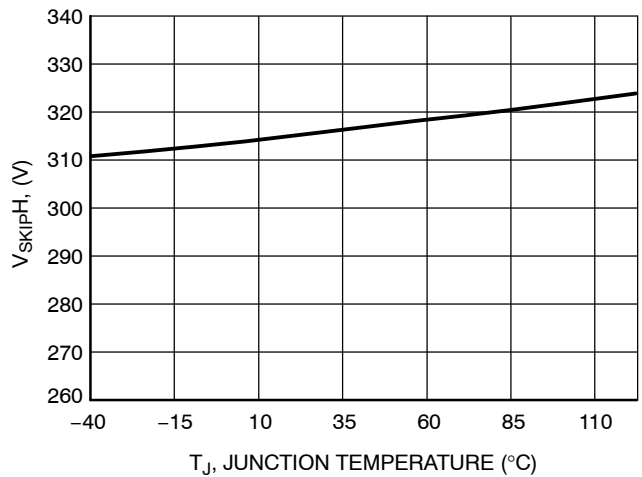
**Figure 44. Ratio (I<sub>PIN6</sub> / I<sub>PIN5</sub>) @ I<sub>PIN5</sub> = 10 µA vs. Temperature**



**Figure 45. Pin 6 Comparator Threshold vs. Temperature**



**Figure 46. Delay from (ZCD Pin Low) to (DRV High) vs. Temperature**



**Figure 47. Skip Cycle Threshold (V<sub>PIN1</sub> Falling) vs. Temperature**

# NCP1605, NCP1605A

[查询"NCP1605DR2G"供应商](#)

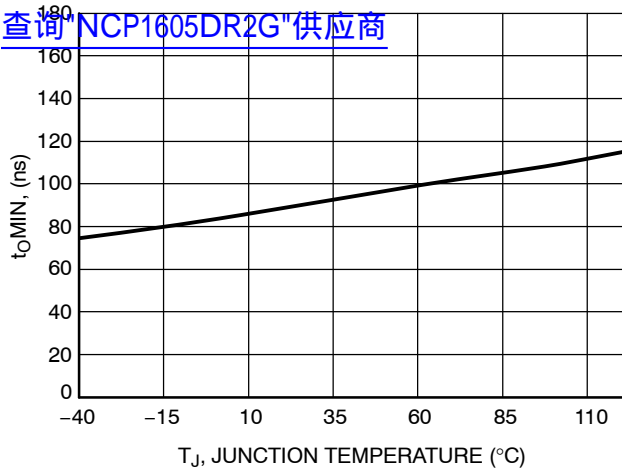


Figure 48. Minimum On-Time vs. Temperature

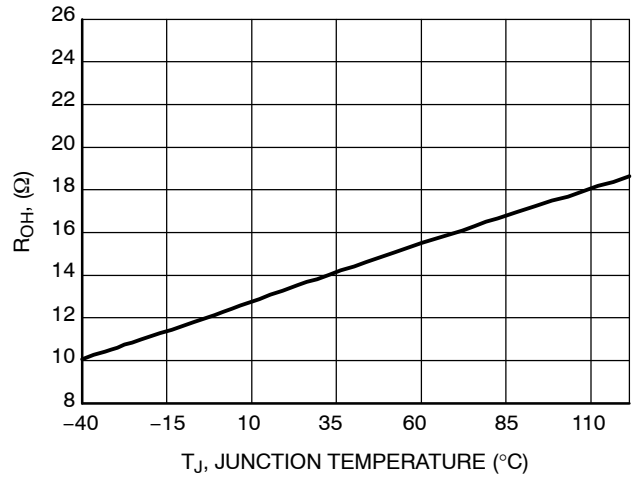


Figure 49. Gate Drive Source Resistance vs. Temperature

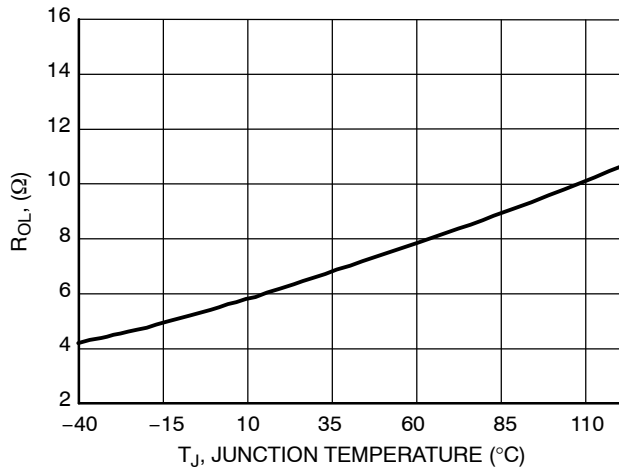
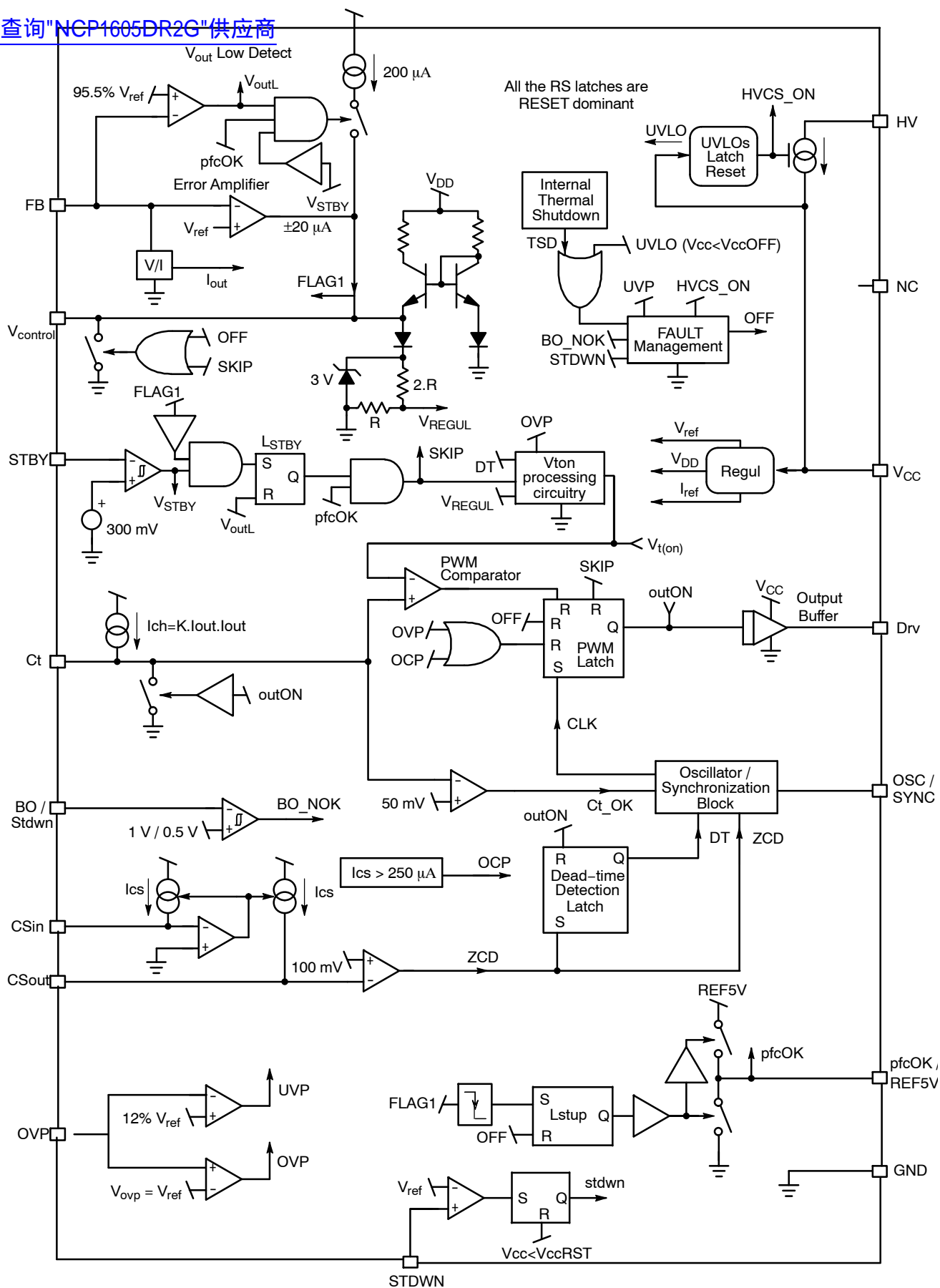


Figure 50. Gate Drive Sink Resistance vs. Temperature

# NCP1605, NCP1605A

[查询"NCP1605DR2G"供应商](#)





### Introduction

The NCP1605(A) is a PFC driver designed to operate in fixed frequency, Discontinuous Conduction Mode (DCM). In the most stressful conditions, Critical Conduction Mode (CRM) can be achieved without power factor degradation and the circuit could be viewed as a CRM controller with a frequency clamp (given by the oscillator). Finally, the NCP1605(A) tends to give the best of both modes without their respective drawbacks. Furthermore, the circuit incorporates protection features for a rugged operation together with some special circuitry to lower the power consumed by the PFC stage in no load conditions. More generally, the NCP1605(A) functions make it the ideal candidate in systems where cost-effectiveness, reliability, low standby power and high power factor are the key parameters:

- **Compactness and Flexibility:** the controller requires few external components while offering a large variety of functions. Depending on the selected coil and oscillator frequency you select, the circuit can:
  1. Mostly operate in CRM and use the oscillator as a frequency clamp.
  2. Mostly operate in fixed frequency mode and only run in CRM at high load and low line.
  3. Permanently operate in fixed frequency mode DCM.

In all cases, the circuit provides near-unity power factor.

**Skip-cycle capability for low power standby:** among other applications, the circuit targets power supply where the PFC stage must keep alive even in standby. A continuous flow of pulses is not compatible with no-load standby power requirements. Instead, the controller slices the switching pattern in bunch of pulses to drastically reduce the overall losses. The skip cycle operation is initiated by applying to Pin 1, a signal that goes below 300 mV in standby. Typically, this signal is drawn from the feedback of the downstream converter.

**Startup Current Source and large  $V_{CC}$  range:** meeting low standby power specifications represents a difficult exercise when the controller requires an external, lossy resistor connected to the bulk capacitor. The controller disables the high-voltage current source after startup which no longer hampers the consumption in no-load situations. In addition, the large  $V_{CC}$  range (10 V to 20 V after startup), highly eases the circuit biasing.

**Fast Line / Load Transient Compensation:** given the low bandwidth of the regulation block, the output voltage of PFC stages may exhibit excessive over and undershoots because of abrupt load or input voltage variations (e.g. at startup). If the output voltage is too far from the regulation level:

- The NCP1605(A) disables the drive to stop delivering power as long as the output voltage exceeds the Overvoltage Protection (OVP) level.
- The NCP1605(A) drastically speeds up the regulation loop when the output voltage is below 95.5% of its regulation level. This function is allowed only after the PFC stage has started up not to eliminate the soft-start effect.

**PFC OK:** the circuit detects when the circuit is in normal situation or if on the contrary, it is in a startup or fault condition. In the first case, Pin 12 is in high state and low otherwise. Pin 12 serves to control the downstream converter operation in response to the PFC state.

**Safety Protections:** the NCP1605(A) permanently monitors the input and output voltages, the coil current and the die temperature to protect the system from possible over-stresses and make the PFC stage extremely robust and reliable. In addition to the aforementioned OVP protection, one can list:

- **Maximum Current Limit and Zero Current Detection:** the circuit permanently senses the coil current and immediately turns off the power switch if it is higher than the set current limit. It also prevents any turn on of the power switch as long as some current flows through the coil, to ensure operation in DCM. This feature also protects the MOSFET from the excessive stress that could result from the large in-rush currents that occurs during the startup phases.
- **Undervoltage Protection:** the circuit turns off when it detects that the output voltage goes below 12% of the OVP level (typically). This feature protects the PFC stage from starting operation in case of too low ac line conditions or in case of a failure in the OVP monitoring network (e.g., bad connection).
- **Brown-Out Detection:** the circuit detects too low ac line conditions and stop operating in this case. This protection protects the PFC stage from the excessive stress that could damage it in such conditions.
- **Thermal Shutdown:** an internal thermal circuitry disables the circuit gate drive and then keeps the power switch off when the junction temperature exceeds 150°C typically. The circuit resumes operation once the temperature drops below about 100°C (50°C hysteresis).

**Output Stage Totem Pole:** the NCP1605(A) incorporates a -0.5 A / +0.8 A gate driver to efficiently drive most TO220 or TO247 power MOSFETs.

## NCP1605(A) Operation Modes

Like the NCP1601, the NCP1605(A):

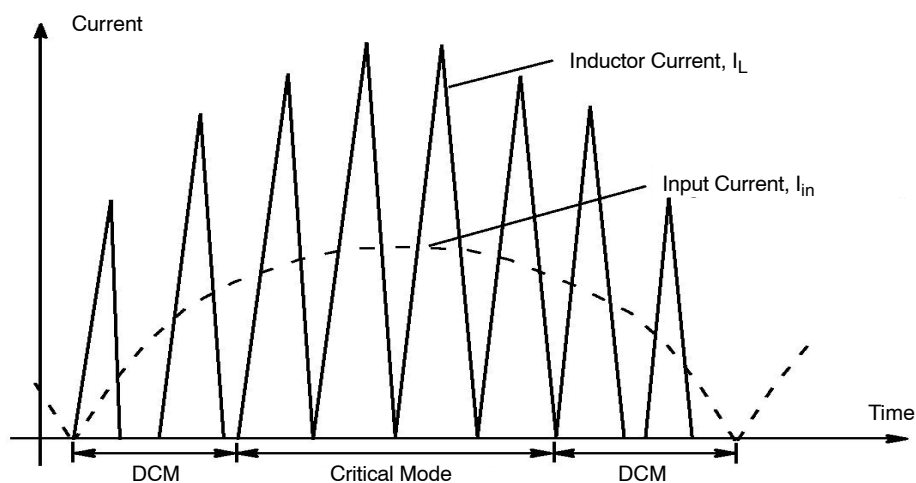
- Features a current sense block that prevents the PFC stage from operating in CCM: as long as the coil current is not null, the power switch is not allowed to turn on. Hence the circuit can only operate in either Fixed Frequency DCM or CRM.
- Features the capability to exhibit near-unity power factor while operating in any type of Discontinuous Conduction Mode operation: DCM or CRM.
- Auto adapts: if there is some current flowing through the coil when the clock occurs to initiate a new current cycle, the PFC stage enters CRM. On the other hand, if the clock occurs during dead-times, one obtains a fixed frequency operation DCM. Thanks to its special oscillator/synchronization arrangement, the circuit automatically enters the appropriate mode CRM or

DCM. It is worth noting that jumps between the CRM and modes cause absolutely no degradation: the input current keeps being properly shaped and there is no discontinuity in the power transfer.

Given the dead-time presence, DCM needs a higher peak inductor current compared to CRM for the same delivered power. Hence, the coil is generally designed to have CRM at the most stressful conditions while DCM limits the switching frequency at lower load. The circuit can also transition within an ac line cycle so that:

- CRM reduces the current stress around the sinusoid top.
- DCM limits the frequency around the line zero crossing.

This capability offers the best of each mode without the drawbacks. The way the circuit modulates the MOSFET on-time allows this facility.



**Figure 52. DCM and CRM Operation Within a Sinusoid Cycle**

The NCP1605(A) can jump from DCM to CRM within a sinusoid cycle (and vice versa) without any discontinuity in the current shaping or the power transfer.

## NCP1605 On-time Modulation

Let's study the ac line current absorbed by the PFC boost. The initial inductor current of each switching cycle is always zero. The coil current ramps up when the MOSFET is *on*. The slope is  $(V_{IN}/L)$  where  $L$  is the coil inductance. At the end of the on-time ( $t_1$ ), the coil demagnetization phase starts. The coil current ramps down until this sequence ends when it reaches zero. The duration of this phase is ( $t_2$ ). The system enters then the dead-time ( $t_3$ ) that lasts until the next clock is generated.

One can show (refer to NCP1601 data sheet) that the ac line current is given by:

$$I_{in} = V_{in} \left[ \frac{t_1 (t_1 + t_2)}{2 T L} \right] \quad (\text{eq. 1})$$

Where  $T = (t_1 + t_2 + t_3)$  is the switching period and  $V_{IN}$  is the ac line rectified voltage.

To the light of this equation, we immediately note that  $I_{IN}$  is proportional to  $V_{IN}$  if  $[t_1(t_1 + t_2)/T]$  is a constant.

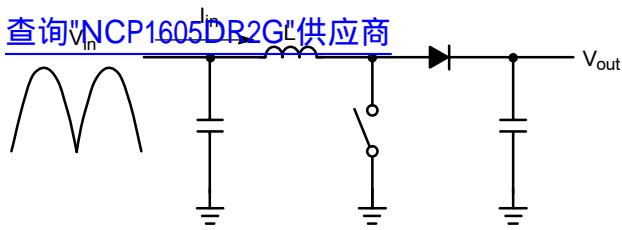


Figure 53. PFC Boost Converter

The NCP1605(A) operates in voltage mode. As portrayed by Figure 55, the MOSFET on time  $t_1$  is controlled by the signal  $V_{ton}$  generated by the regulation block and the Pin 4 ramp as follows:

$$t_1 = \frac{C_{pin7} \cdot V_{TON}}{I_{pin7}} \quad (\text{eq. 2})$$

The charge current that is sourced by Pin 7 [ $I_{pin7} = 60 \mu\text{A}/\text{V}^2 * (V_{Pin4})^2$ ] is constant at a given input voltage ( $V_{Pin4}$  is proportional to the output voltage).  $C_{pin7}$  that is the capacitor connected between Pin 7 and ground is also a constant. Hence, the power factor correction is achieved when the  $V_{TON} (t_1 + t_2)/T$  term is constant.

The output of the regulation block ( $V_{CONTROL}$ ) is linearly changed into a signal ( $V_{REGUL}$ ) varying between 0 and 1 V. ( $V_{REGUL}$ ) is the voltage that is injected into the PWM section to modulate the MOSFET duty-cycle. However, like the NCP1601, the NCP1605(A) inserts some circuitry that processes ( $V_{REGUL}$ ) to form the signal ( $V_{TON}$ ) that is used in the PWM section instead of ( $V_{REGUL}$ ) (see Figure 56). ( $V_{TON}$ ) is modulated in response to the dead-time sensed during the precedent current cycles, that is, for a proper shaping of the ac line current (refer to NCP1601 data sheet). This modulation leads to:

$$V_{TON} = \frac{T \cdot V_{REGUL}}{t_1 + t_2} \quad \text{or:} \quad V_{TON} \cdot \frac{t_1 + t_2}{T} = V_{REGUL} \quad (\text{eq. 3})$$

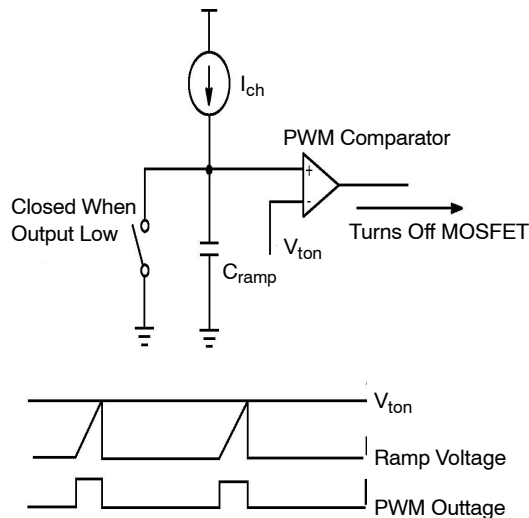


Figure 55. PWM Circuit and Timing Diagram

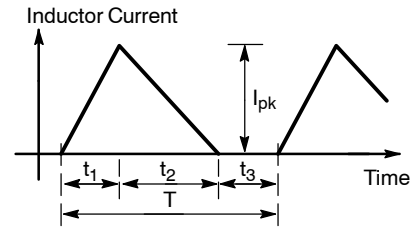


Figure 54. Inductor Current in DCM

Given the regulation low bandwidth of the PFC systems, ( $V_{CONTROL}$ ) and then ( $V_{REGUL}$ ) are slow varying signals. Hence, the ( $V_{TON} * (t_1 + t_2)/T$ ) term is substantially constant. Provided that in addition, ( $t_1$ ) is proportional to ( $V_{TON}$ ), equation (1) leads to: ( $I_{in} = k * V_{in}$ ), where  $k$  is a constant. More exactly:

$$I_{in} = k \cdot V_{in} \quad \text{where:} \quad k = \text{constant} = \left[ \frac{C_{pin7} \cdot V_{REGUL}}{120 \mu \cdot L \cdot (V_{pin2})^2} \right] \quad (\text{eq. 4})$$

The input current is then proportional to the input voltage. Hence, the ac line current is properly shaped.

One can note that this analysis is also valid in the CRM case. This condition is just a particular case of this functioning where ( $t_3 = 0$ ), which leads to ( $t_1 + t_2 = T$ ) and ( $V_{TON} = V_{REGUL}$ ). That is why the NCP1605 automatically adapts to the conditions and jumps from DCM and CRM (and vice versa) without power factor degradation and without discontinuity in the power delivery.

**Remark:** Like in the NCP1601, the “ $V_{TON}$  processing circuit” is “informed” when there is an OVP condition, not to over-dimension  $V_{TON}$  in that conditions. Otherwise, an OVP sequence would be viewed as a dead-time phase by the circuit and  $V_{TON}$  would inappropriately increase to compensate it.

Similarly, the “ $V_{TON}$  processing circuit” is inhibited for a skip sequence not to over-dimension “ $V_{TON}$ ” in this case (refer to Figure 56).

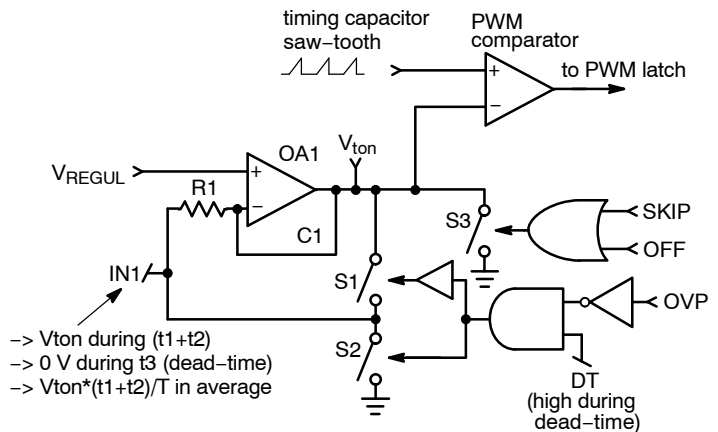


Figure 56.  $V_{TON}$  Processing Circuit

The integrator OA1 amplifies the error between  $V_{REGUL}$  and  $IN1$  so that in average, ( $V_{TON} * (t_1 + t_2)/T$ ) equates  $V_{REGUL}$ .

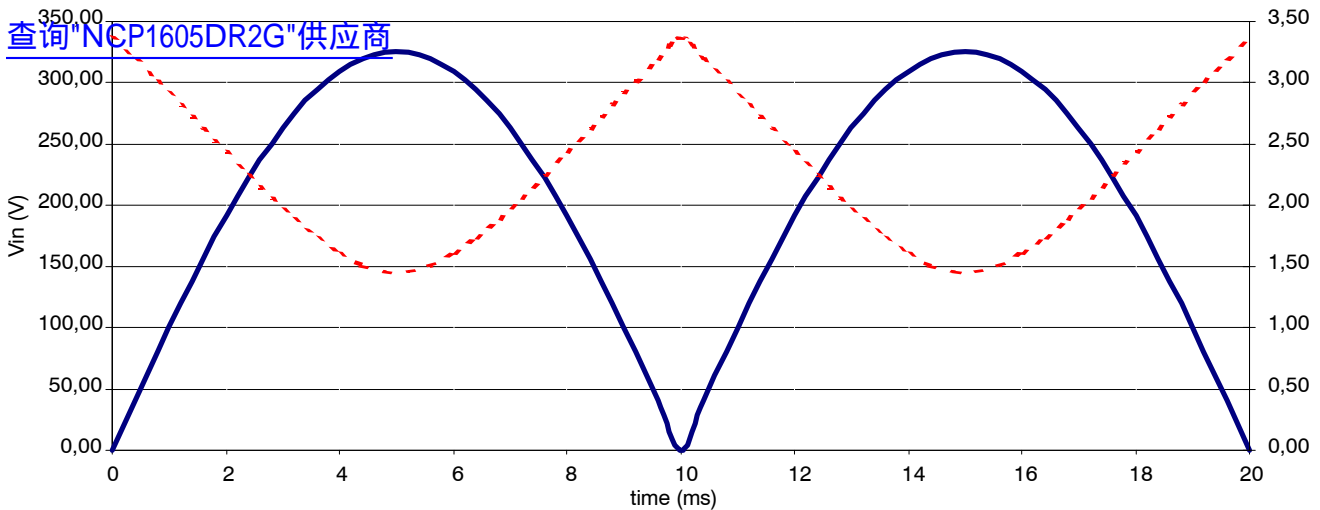


Figure 57. Input Voltage and On-time vs Time (example with  $F_{SW} = 100 \text{ kHz}$ ,  $P_{in} = 150 \text{ W}$ ,  $V_{AC} = 230 \text{ V}$ ,  $L = 200 \mu\text{H}$ )

**Regulation Block and Low Output Voltage Detection**

A transconductance error amplifier with access to the inverting input and output is provided. It features a typical transconductance gain of  $200 \mu\text{S}$  and a maximum capability of  $\pm 20 \mu\text{A}$ . The output voltage of the PFC stage is typically scaled down by a resistors divider and monitored by the inverting input (feedback pin – Pin 4). The bias current is minimized (less than  $500 \text{ nA}$ ) to allow the use of a high impedance feedback network. The output of the error amplifier is pinned out for external loop compensation (Pin 3). Typically a capacitor in the range of  $100 \text{ nF}$ , is applied between Pin 3 and ground, to set the regulation bandwidth below  $20 \text{ Hz}$ , as need in PFC applications.

The swing of the error amplifier output is limited within an accurate range:

- It is forced above a voltage drop ( $V_F$ ) by some circuitry.
- It is clamped not to exceed  $3.0 \text{ V} +$  the same  $V_F$  voltage drop.

Hence,  $V_{Pin3}$  features a  $3 \text{ V}$  voltage swing.  $V_{Pin3}$  is then offset down by ( $V_F$ ) and divided by three before it connects to the “ $V_{TON}$  processing block” and the PWM section. Finally, the output of the regulation is a signal (“ $V_{REGUL}$ ” of the block diagram) that varies between  $0$  and  $1 \text{ V}$ .

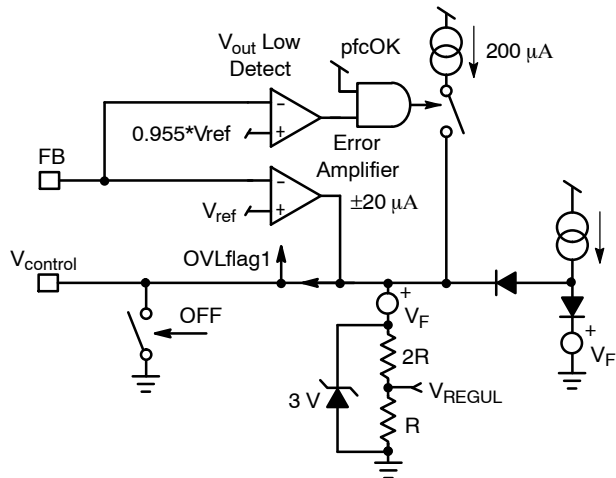


Figure 58. Regulation Block

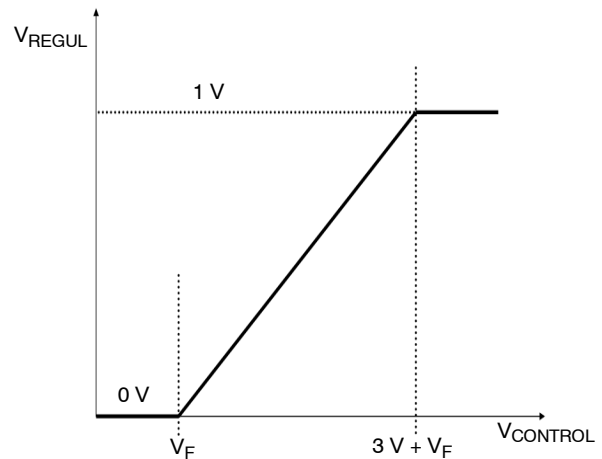


Figure 59. Correspondence between  $V_{CONTROL}$  and  $V_{REGUL}$

Provided the low bandwidth of the regulation loop, sharp variations of the load, may result in excessive over and undershoots. Overshoots are limited by the Overvoltage Protection (see OVP section). To contain the undershoots, an internal comparator monitors the feedback ( $V_{Pin4}$ ) and when  $V_{Pin4}$  is lower than  $95.5\%$  of its nominal value, it connects a

$200 \mu\text{A}$  current source to speed-up the charge of the compensation capacitor ( $C_{pin3}$ ). Finally, it is like if the comparator multiplied the error amplifier gain by  $10$ .

One must note that this circuitry for undershoots limitation, is not enabled during the startup sequence of the PFC stage but only once the converter has stabilized (that is when the

“ok” signal of the block diagram, is high). This is because, at the beginning of operation, the Pin 3 capacitor must charge slowly and gradually for a soft-startup.

**Remark:** As shown in block diagram, the circuitry for undershoots limitation is disabled as long as Pin 3 detects standby conditions ( $V_{Pin3} < 300 \text{ mV}$ ). This is to suppress the risk of audible noise in standby thanks to the soft-start that softens the bursts.

### On-Time Control for Maximum Power Adjustment

As aforementioned, the NCP1605(A) processes the error amplifier output voltage to form a signal ( $V_{TON}$ ) that is used by the PWM section to control the on-time. ( $V_{TON}$ ) compensates the relative weight of the dead-time sequences measured during the precedent current cycles. During the conduction time of the MOSFET, Pin 7 sources a current that is proportional to the square of the voltage applied to Pin 4 (feedback pin). Practically, as Pin 4 receives a portion of the output voltage ( $V_{OUT}$ ),  $I_{Pin7}$  is proportional to the square of  $V_{OUT}$ .

The MOSFET turns off when the Pin 7 voltage exceeds  $V_{TON}$ . Hence, the MOSFET on-time ( $t_1$ ) is given by:

$$t_1 = \frac{C_{pin7} V_{TON}}{k V_{OUT}^2} \text{ where } k \text{ is a constant.}$$

The coil current averaged over one switching period is:

$$\langle I_{COIL} \rangle_T = I_{IN}(t) = \frac{V_{IN} t_1 (t_1 + t_2)}{2L T}$$

Where  $I_{IN}(t)$  and  $V_{IN}(t)$  are the instantaneous input current and voltage, respectively,  $t_2$  is the core reset time and  $T$  is the switching period. Hence, the instantaneous input power is given by the following equation:

$$P_{IN}(t) = V_{IN}(t) I_{IN}(t) = \frac{C_{pin7} V_{IN}^2}{2L k V_{OUT}^2} \cdot \frac{V_{TON} (t_1 + t_2)}{T}$$

As aforementioned, we have:  $V_{TON} (t_1 + t_2)/T = V_{REGUL}$  where  $V_{REGUL}$  is the signal outputted by the regulation block. Hence, the average input power is:

$$\langle P_{IN} \rangle = \frac{C_{pin7} V_{ac}^2}{2L k V_{OUT}^2} V_{REGUL}$$

The maximum value of  $V_{REGUL}$  being 1 V, the maximum power that can be delivered is:

$$\langle P_{IN} \rangle_{MAX} = \frac{C_{pin7} V_{ac}^2}{2L k V_{OUT}^2} 1 \text{ V}$$

To the light of the last equations, one can note that the PFC power capability is inversely proportional to the square of the output voltage. One sees that if the power demand is too high to keep the regulation, ( $V_{REGUL}=1\text{V}$ ) and the power delivery depends on the output voltage level that stabilizes to the following value:

$$V_{OUT} = \sqrt{\frac{C_{pin7} 1 \text{ V}}{2L k \eta P_{OUT}}} V_{ac}$$

Where:

- $P_{OUT}$  is the output power.
- And  $\eta$  is the efficiency.

Hence, one obtains the Follower Boost characteristics. The “Follower Boost” is an operation mode where the pre-converter output voltage stabilizes at a level that varies linearly versus the ac line amplitude. This technique aims at reducing the gap between the output and input voltages to optimize the boost efficiency and minimize the cost of the PFC stage (refer to the MC33260 data sheet for more information, at:

<http://www.onsemi.com/pub/Collateral/MC33260-D.PDF>).

**Remark:** the timing capacitor applied to Pin 7 is discharged and maintained grounded when the drive is low. Furthermore, the circuit compares the Pin 7 voltage to an internal reference 50 mV and prevents the PWM latch from being set as long as  $V_{Pin7}$  is higher than this low threshold. This is to guarantee that the timing capacitor is properly discharged before starting a new cycle.

### Current Sense and Zero Current Detection

The NCP1605(A) is designed to monitor a negative voltage proportional to the coil current. Practically, a current sense resistor ( $R_{CS}$ ) is inserted in the return path to generate a negative voltage proportional to the coil current ( $V_{CS}$ ). The circuit uses  $V_{CS}$  for two functions: the limitation of the maximum coil current and the detection of the core reset (coil demagnetization). To do so, the circuit incorporates an operational amplifier that sources the current necessary to maintain the CS pin voltage null (refer to Figure 60). By inserting a resistor  $R_{OCP}$  between the CS pin and  $R_{CS}$ , we adjust the CS pin current as follows:

$$- [R_{CS} I_{COIL}] + [R_{OCP} I_{pin5}] = V_{pin5} \approx 0$$

Which leads to:

$$I_{pin5} = \frac{R_{CS}}{R_{OCP}} I_{COIL}$$

In other words, the Pin 5 current is proportional to the coil current.

$I_{pin5}$  is utilized as follows:

- If  $I_{pin5}$  exceeds 250  $\mu\text{A}$ , an overcurrent is detected and the PWM latch is reset. Hence, the maximum coil current is:

$$(I_{COIL})_{max} = \frac{R_{OCP}}{R_{CS}} 250 \mu\text{A}$$

The propagation delay ( $I_{pin5}$  higher than 250  $\mu\text{A}$ ) to (drive output low) is in the range of 100 ns, typically.

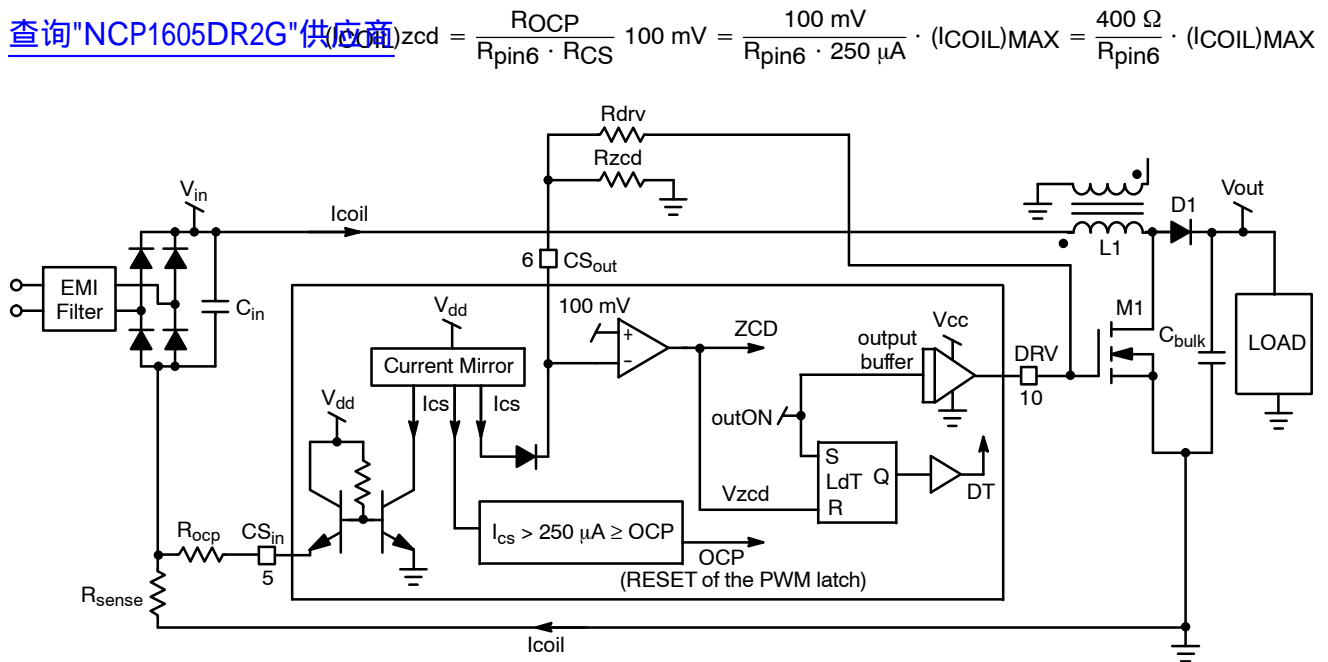
- The Pin 5 current is internally copied and sourced by Pin 6. Place a resistor ( $R_{Pin6}$ ) between Pin 6 and ground to build a voltage proportional to the coil current. The circuit detects the core reset when  $V_{Pin6}$  drops below 100 mV, typically. The Pin 6 voltage equating:

$$V_{pin6} = \frac{R_{pin6} \cdot R_{cs}}{R_{cs}} \cdot I_{COIL},$$

the coil current threshold for zero current detection is:

## NCP1605, NCP1605A

[查询"NCP1605DR2G"供应商](#)



**Figure 60. Current Sense Block**

The CS block performs the overcurrent protection and the zero current detection.

The propagation delay ( $V_{\text{Pin6}}$  lower than 100 mV) to (drive output high) is in the range of 300 ns, typically.

The Zero Current Detection:

- Is used to detect the dead-time sequences (“DT” high) and hence, to process ( $V_{\text{TON}}$ ) from the error amplifier output ( $V_{\text{CONTROL}}$ ). In other words, this is an input of the on-time modulation block.
- Prevents the MOSFET from turning on as long as the “DT” and “ZCD” signals are low. This is the case as long as some current flows through the coil. This delaying action on the output stage tends to make the MOSFET turn on at the valley. To further optimize the valley switching, one can apply the voltage of an auxiliary winding to Pin 6 ( $\text{CS}_{\text{OUT}}$ ). The voltage is compared to an internal 100 mV reference, so that ZCD turns high only if ( $V_{\text{Pin6}} < 100 \text{ mV}$ ).

### Remarks:

- A resistor can be placed between Pin 6 and ground to increase the ZCD precision.

- It is worth highlighting that the circuit permanently senses the coil current and that it prevents any turn on of the power switch as long as the core is not reset. This feature protects the MOSFET from the possible excessive stress it could suffer from, if it was allowed to turn on while a huge current flows through the coil. In particular, this scheme effectively protects the PFC stage during the startup phase when huge in-rush currents charge the output capacitor.
- In addition this detection method does not require any auxiliary winding. A simple coil can then be used in the PFC stage.

### It is recommended to:

1. Keep  $R_{\text{OCP}}$  equal to or lower than 5 k $\Omega$
2. Choose  $R_{\text{ZCD}}$  as high as possible but not bigger than ( $3 \times R_{\text{OCP}}$ ). This is to avoid that the Pin 6 leakage prevents a proper zero current detection. For instance, if  $R_{\text{OCP}}$  is 2.2 k $\Omega$ ,  $R_{\text{ZCD}}$  should not exceed 6.6 k $\Omega$ .

3 Place a resistor  $R_{DRV}$  between the drive pin and Pin 6 to ease the circuit detection by creating some over-riding at the turn on instant.  $R_{DRV}$  should be selected in the range of 3 times  $R_{ZCD}$ . For instance, if  $R_{ZCD}$  is 6.2 k $\Omega$ , a 22 k $\Omega$  resistor can be used for  $R_{DRV}$ .

## Overvoltage Protection

While PFC circuits often use one single pin for both the Overvoltage Protection (OVP) and the feedback, the

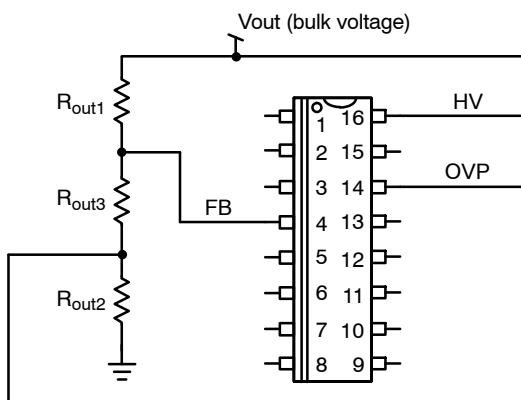


Figure 61. Configuration with One Feedback Network for Both OVP and Regulation

The double feedback configuration offers some up-graded safety level as it protects the PFC stage even if there is a failure of one of the two feedback arrangements.

However, if wished, one single feedback arrangement is possible as portrayed by Figure 61. The regulation and OVP blocks having the same reference voltage, the resistance ratio  $R_{out2}$  over  $R_{out3}$  adjusts the OVP threshold. More specifically,

The bulk regulation voltage is:

$$V_{out} = \frac{R_{out1} + R_{out2} + R_{out3}}{R_{out2} + R_{out3}} \cdot V_{ref}$$

The OVP level is:

$$V_{ovp} = \frac{R_{out1} + R_{out2} + R_{out3}}{R_{out2}} \cdot V_{ref}$$

The ratio OVP level over regulation level is:

$$\frac{V_{ovp}}{V_{out}} = 1 + \frac{R_{out3}}{R_{out2}}$$

For instance, ( $V_{OVP} = 105\% \cdot V_{out}$ ) leads to the following constraint: ( $R_{out3} = 5\% \cdot R_{out2}$ ).

As soon and as long as the circuit detects that the output voltage exceeds the OVP level, the power switch is turned off to stop the power delivery.

**Remark:** Like in the NCP1601, the “ $V_{TON}$  processing circuit” is “informed” when there is an OVP condition, not to over-dimension  $V_{TON}$  in that conditions. Otherwise, an OVP sequence would be viewed as a dead-time phase by the circuit and  $V_{TON}$  would inappropriately increase to compensate it (refer to Figure 56).

NCP1605(A) dedicates one specific pin for the undervoltage and overvoltage protections. The NCP1605(A) configuration allows the implementation of two separate feedback networks (see Figure 62):

- One for regulation applied to Pin 4.
- Another one for the OVP function.

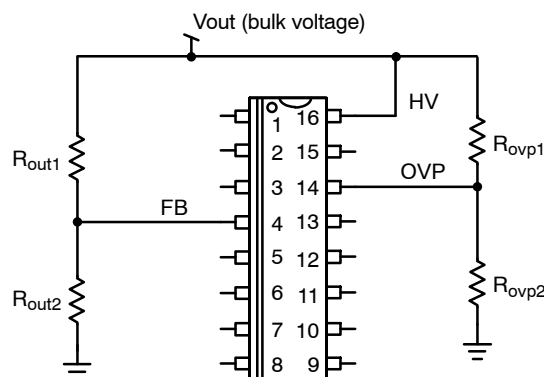


Figure 62. Configuration with Two Separate Feedback Networks

## PfcOK / REF5V Signal

The NCP1605(A) can communicate with the downstream converter. The signal “pfcOK/REF5V is high (5 V) when the PFC stage is in normal operation (its output voltage is stabilized at the nominal level) and low otherwise.

More specifically, “pfcOK/REF5V” is low:

- During the PFC stage startup, that is, as long as the output voltage has not yet stabilized at the right level. The startup phase is detected by the latch “ $L_{STUP}$ ” of the block diagram. “ $L_{STUP}$ ” is set during each “off” phase so that its output (“STUP”) is high when the circuit enters an active phase. The latch is reset when the error amplifier stops charging its output capacitor, that is, when the output voltage of the PFC stage has reached its desired regulation level. At that moment, “STUP” falls down to indicate the end of the startup phase.
- In case of a condition preventing the circuit from operating properly, i.e., during the  $V_{CC}$  charge by the high voltage startup current source, in a Brown-out case or when one of the following major faults turns off the circuit:
  - Incorrect feeding of the circuit (“UVLO” high when  $V_{CC} < V_{CCOFF}$ ,  $V_{CCOFF}$  equating 9 V typically).
  - Excessive die temperature detected by the thermal shutdown.
  - Undervoltage Protection

## NCP1605, NCP1605A

Latched off of the circuit (when the “STDWN” pin,  $V_{Pin1}$ , exceeds 2.5 V).

And “pfcOK/REF5V” is high when the PFC output voltage is properly and safely regulated. “pfcOK/REF5V” should be used to allow operation of the downstream converter.

### Standby Management

The NCP1605(A) automatically skips switching cycles when the power demand drops below a given level. This is

accomplished by monitoring the Pin 1 voltage that must receive a voltage below 300 mV in light load conditions. Practically, a portion of the feedback signal of the downstream converter (or some other signal able to indicate that the power demand is low) should be applied to Pin 1.

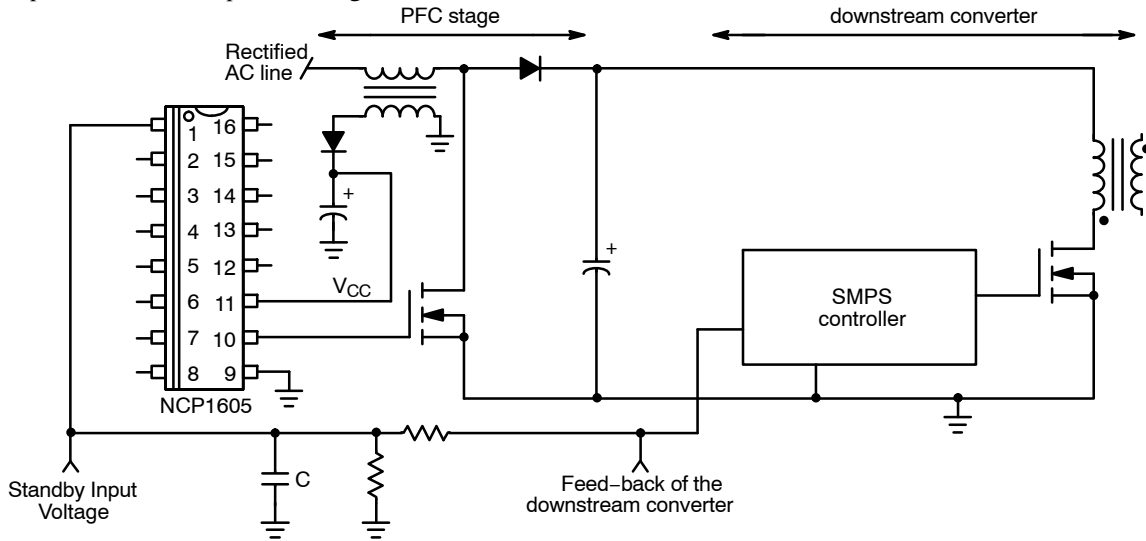


Figure 63. Signal for Standby Detection

In normal operation, the circuit controls the *continuous* absorption of the line current necessary for matching the load power demand. When the voltage applied to Pin 1 goes below 300 mV:

- The output pulses are blanked and Pin 3 (“V<sub>CONTROL</sub>”) is grounded.
- The output of the PFC stage being not fed any more, it drops. When the output voltage goes below 95.5% of the regulation level, the circuit resumes operation until “FLAG1” becomes low (what means that the output voltage has exceeded the regulation level).
- At that moment, if  $V_{Pin1}$  is still below 300 mV, a new skipping phase starts.

In other words, instead of continuously providing the output with a small amount of power, the circuit operates from time to time at a higher power level. As an example and to make it simple, instead of continuously supplying 1% of  $P_{MAX}$ , the circuit can provide the load with 10% of  $P_{MAX}$  for 10% of the time. The IC enters the so-called skip cycle mode, also named controlled burst operation. This burst operation is much more efficient compared to a continuous power flow as it drastically reduces the number of pulsations and therefore the switching losses associated to them.



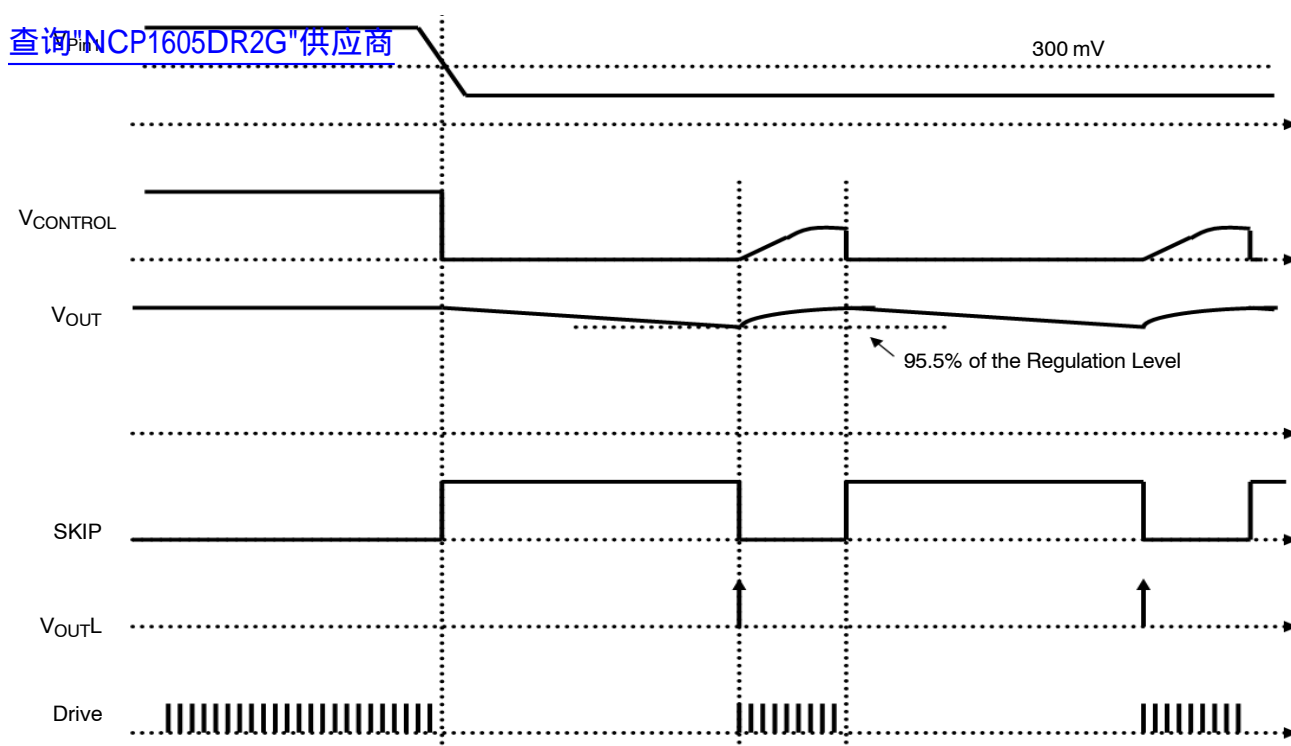


Figure 64. Standby Management

**Remark:**

- Skip cycle is not allowed during the PFC startup phase to avoid that it interferes with the soft-start. That is why, skip cycle is enabled only when “pfcOK” is high.
- Each working phase of the burst mode starts smoothly as Pin 3 is grounded at the beginning of it. This soft-start capability is effective to avoid the audible noise that could possibly result from such a burst operation.
- The circuit leaves the standby mode when the output voltage goes below 95.5% of its regulation level **and**  $V_{Pin1}$  is above 330 mV (300 mV + 30 mV hysteresis).

**Oscillator / Synchronization Section**

The oscillator generates the clock signal to set the PWM latch and turn the MOSFET on. The oscillator frequency is set by the capacitor that is applied to Pin 8. Typically, 820 pF force about 60 kHz. The maximum allowable oscillator frequency is 250 kHz. The clock frequency can also be driven by an external synchronization signal.

This block contains two main parts (refer to Figure 66):

- The arrangement that consists of charging/discharging current sources, a switch and a comparator. When used in oscillator mode, a capacitor is connected between Pin 8 and ground. A current source (100  $\mu$ A) charges the Pin 8 capacitor until its voltage exceeds  $V_{oscH}$ . At that moment, the comparator (“COMP\_OSC”) turns high and activates the discharge current source (200  $\mu$ A). As a consequence, Pin 8 actually sinks 100  $\mu$ A that discharge the oscillator capacitor to  $V_{oscL}$ . At that moment, the comparator turns low and initiates a new charge phase. If the circuit is to be externally triggered, the synchronization signal must cross  $V_{oscL}$  and  $V_{oscH}$  to

properly turn on and off the “COMP\_OSC” comparator. Also the synchronization signal must be low impedance enough not to be distorted by the Pin 8 source and sink currents.

- The “storing circuitry” that contains a latch and some gates. The raising edge of the “COMP\_OSC” output sets the “CLOCK Generation” latch to turn high the “CLK” signal. If the timing capacitor of Pin 7 is properly discharged ( $V_{Pin4} < 50$  mV leading to “CTOK” high), the PWM block is ready for a new cycle and “CLK” can force the signal “VSET” in high state. As a consequence, the PWM latch sets. In addition, “VSET” resets the “CLOCK Generation” latch to make it ready for the next oscillator cycle. The two inverters of Figure 66, simply generate some delay to ensure that “VSET” keeps high long enough to set the PWM latch and reset the “CLOCK Generation” latch (longer delay than that produced by the two gates, may actually be necessary). The oscillator / Synchronization block is designed to set the switching frequency.

However, the coil current can possibly be non zero at the end of a clock period and the circuit would enter Continuous Conduction Mode (CCM) if the MOSFET turned on in that moment. In order to prevent CCM, the “storing circuitry” of the oscillator / synchronization block, memorizes the “COMP\_OSC” rising edge (thanks to the “CLOCK Generation” latch) and delays the next MOSFET conduction time until the coil current has totally vanished (that is until the signal “DT” is high – “DT” is generated by the current sense block so that it is high during the dead-time and low otherwise). In other words, CRM operation is obtained (refer to Figure 65).

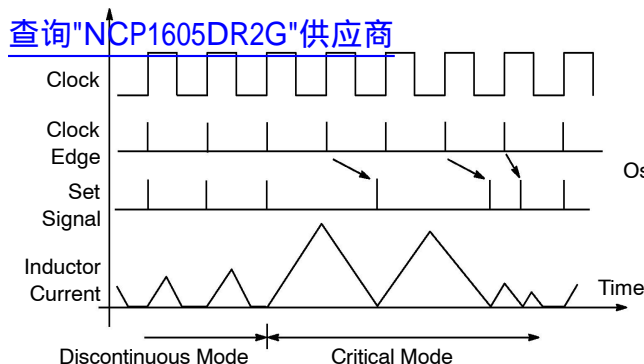


Figure 65. Oscillator Timing Diagram

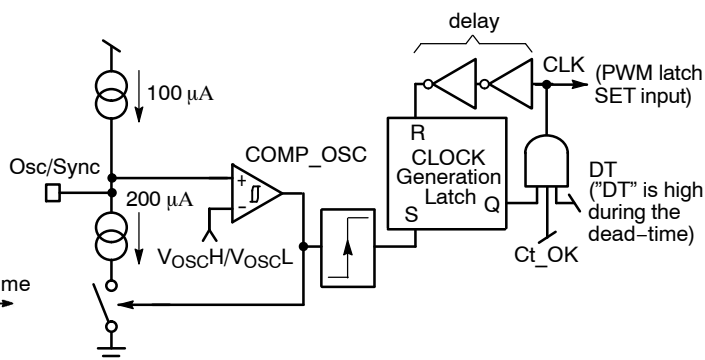
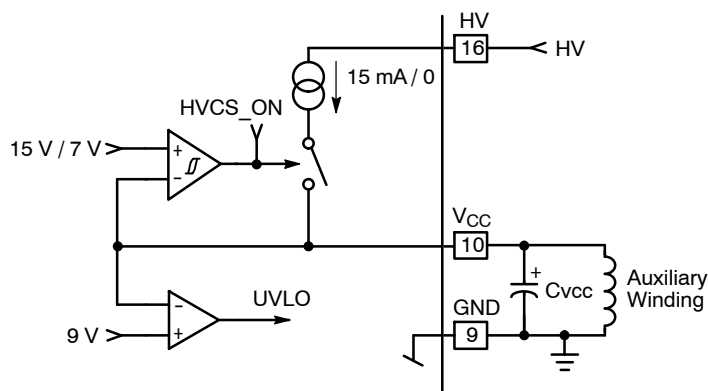


Figure 66. Oscillator / Synchronization Block



(When high, "UVLO" indicates that the circuit is not properly fed and it sets the Fault latch to turn off the circuit)

Figure 67. The Current Source brings  $V_{CC}$  above 15 V and then Turns Off

### Startup Sequence / $V_{CC}$ Management

At the moment when the PFC stage is plugged to the mains outlet, the internal current source starts charging the  $V_{CC}$  capacitor. More generally, the startup current source is enabled whenever  $V_{CC}$  drops below  $V_{CCSTUP}$  (7 V, typically). When  $V_{CC}$  exceeds the  $V_{CCON}$  level (typically 15 V for the NCP1605, 10.5 V for the NCP1605A), the current source turns off and the circuit starts pulsing.

The energy stored by the  $V_{CC}$  capacitor serves to feed the controller and some auxiliary supply must take over before  $V_{CC}$  drops below  $V_{CCOFF}$  (9 V, typically), that is, the level below which the circuit stops pulsing.

Hence, the circuit starts operating when the  $V_{CC}$  voltage exceeds  $V_{CCON}$  and stops pulsing when  $V_{CC}$  drops below  $V_{CCOFF}$ . The hysteresis (6 V for the NCP1605, 1.5 V for the NCP1605A) prevents erratic operation as the  $V_{CC}$  crosses the  $V_{CCON}$  threshold.

Figure 67 shows the internal arrangement of this structure (the  $V_{CC}$  turn on threshold of Figure 67 is that of

the NCP1605). One can note that the startup current source is *on* during the  $V_{CC}$  charging phase and *off* for the rest of the time. Hence, it spends no power during the PFC stage operation and in particular, in light load conditions. That is why the NCP1605(A) helps meet the most stringent standby requirements.

### Remarks:

- Some circuitry (not represented in Figure 67) limits the HV pin current below 1 mA if the  $V_{CC}$  voltage is nearly below 1 V. This protects the circuit when the  $V_{CC}$  pin is accidentally grounded. The full current capability (around 15 mA) is obtained when  $V_{CC}$  exceeds about 1 V.
- The circuit is also kept off when the startup current source is on to make a clear distinction between the  $V_{CC}$  charge phase and the operating sequence (refer to "HVCS\_ON" signal on block diagram).

## Brown-Out Detection

[查询"NCP1605DR2G"供应商](#)

The brown-out pin receives a portion of the input voltage ( $V_{IN}$ ). As  $V_{IN}$  is a rectified sinusoid, a capacitor must integrate the ac line ripple so that a voltage proportional to the average value of ( $V_{IN}$ ) is applied to the brown-out pin.

The brown-out block detects too low input voltage conditions. A hysteresis comparator monitors the Pin 2 voltage. Before operation, the PFC stage is off and the input bridge acts as a peak detector. Hence, the voltage applied to Pin 2 is:

$$V_{pin2} = \sqrt{2} V_{ac} \frac{R_{bo2}}{R_{bo1} + R_{bo2}}$$

After the PFC stage has started operation, the input voltage becomes a rectified sinusoid and the voltage applied to Pin 2 is:

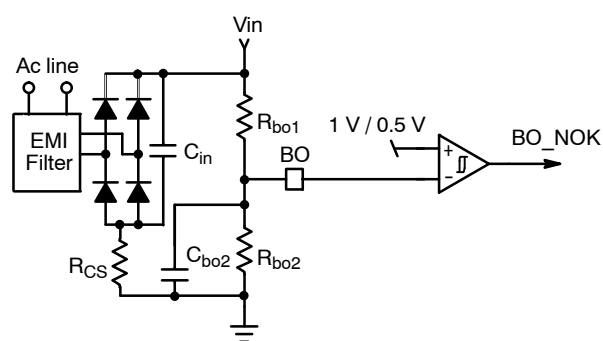


Figure 68. Brown-Out Block

## Thermal Shutdown (TSD)

An internal thermal circuitry disables the circuit gate drive and then keeps the power switch off when the junction temperature exceeds 150°C typically. The output stage is then enabled once the temperature drops below about 100°C (50°C hysteresis).

The temperature shutdown keeps active as long as the circuit is not reset, that is, as long as  $V_{CC}$  keeps higher than  $V_{CCRESET}$ . The reset action forces the TSD threshold to be the upper one (150°C). This ensures that any cold startup will be done with the right TSD level.

## Output Drive Section

The output stage contains a totem pole optimized to minimize the cross conduction current during high frequency operation. The gate drive is kept in a sinking mode whenever the Undervoltage Lockout is active or more generally whenever the circuit is off (i.e., when the "Fault Latch" of the block diagram is high or when the HV current source is on). Its high current capability (-500 mA/+800 mA) allows it to effectively drive high gate charge power MOSFET.

## Reference Section

The circuit features an accurate internal reference voltage ( $V_{REF}$ ).  $V_{REF}$  is optimized to be  $\pm 3\%$  accurate over the temperature range (the typical value is 2.5 V).  $V_{REF}$  is

$$V_{pin2} = \frac{2\sqrt{2} V_{ac}}{\pi} \frac{R_{bo2}}{R_{bo1} + R_{bo2}},$$

i.e., about 64% of the previous value. Therefore, the same line magnitude leads to a  $V_{Pin2}$  voltage that is 36% lower when the PFC is working than when it is off (refer to Figure 69). That is why the NCP1605(A) features a 50% hysteresis ( $V_{BO L} = 50\% V_{BO H}$ ).

When the circuit starts operation, the input voltage equates the ac line peak.

**Hence, the initial threshold of the Brown-Out comparator, must be the upper one ( $V_{BO} = V_{BO H} = 1 V$  when the NCP1605 leaves the off mode).**

When a brown-out condition is detected, the signal "BO\_NOK" turns off the circuit (refer to block diagram).

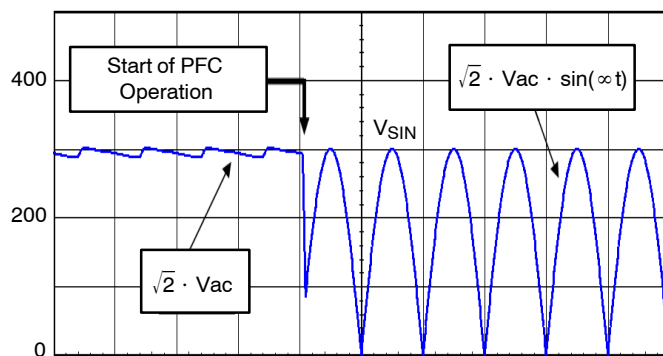


Figure 69. Typical Input Voltage of a PFC Stage

the voltage reference used for the regulation and the overvoltage protection. The circuit also incorporates a precise current reference ( $I_{REF}$ ) that allows the Overcurrent Limitation to feature a  $\pm 6\%$  accuracy over the temperature range.

## OFF Mode

As previously mentioned, the circuit turns off in the following cases:

- When the high voltage, startup current source charges the  $V_{CC}$  capacitor.
- When one of the following major faults is detected:
- Incorrect feeding of the circuit ("UVLO" high when  $V_{CC} < V_{CCOFF}$ ,  $V_{CCOFF}$  equating 9 V typically).
- Excessive die temperature detected by the thermal shutdown.
- Brown-Out condition.
- Undervoltage Protection.
- $V_{Pin13}$  higher than 2.5 V ("STDWN" of the block diagram turns high).

Generally speaking, the circuit turns off when the conditions are not proper for good operation. In this mode, the controller stops operating. The major part of the circuit sleeps and its consumption is minimized ( $< 500 \mu A$ ).

## NCP1605, NCP1605A

More specifically, when the circuit is in OFF state:

- The drive output is kept low
- All the blocks are off except:
  1. The UVLO circuitry that keeps monitoring the  $V_{CC}$  voltage and controlling the startup current source accordingly.
  2. The TSD (thermal shutdown)
  3. The “STDWN” latch that stores its output state.
  4. The Undervoltage Protection (“UVP”).
  5. The brown-out circuitry. One must note that the comparator is reset during the latched-off phase so that its threshold is the upper one (1 V) when the circuit enters the active phase (refer to next “ $V_{CC}$  sequences” section).
  6. The high voltage, startup current source when the circuit is in startup phase (that is when  $V_{CC}$  is lower than  $V_{CCSTUP}$ ).

- The Pin 3 capacitor is discharged and kept grounded along the OFF time, to initialize it for the next operating sequence, where it must be slowly and gradually charged to offer some soft-start.
- The “pfcOK” pin is grounded.
- The output of the “ $V_{TON}$  processing block” is grounded

### $V_{CC}$ Sequences

The following table summarizes the state of the circuit in accordance to the  $V_{CC}$  level.

$V_{CC}$ Conditions	“OFF” is Low (no condition forces the circuit off)	“OFF” is High (due to some protection like the thermal shutdown)
$V_{CC}$ exceeds $V_{CCON}$ ⇒ the circuit enters the working phase	The startup current source is disabled The circuit is fully active	The startup current source is disabled The circuit is in OFF state
$V_{CC}$ drops below $V_{CCOFF}$ ⇒ the circuit enters the latched-off phase	The circuit is in OFF state The brown-out block resets during the latched-off phase so that its comparator threshold is forced to be the upper one (1 V)	The circuit is in OFF state The brown-out block resets during the latched-off phase so that its comparator threshold is forced to be the upper one (1 V)
$V_{CC}$ goes below $V_{CCSTUP}$ ⇒ the circuit enters the startup phase	The high voltage, startup current source turns on to charge $V_{CC}$ . The drive output and the “pfcOK” are in low state (the circuit is off) All the circuit blocks are reset except: The thermal shutdown (TSD) and the brown-out block that keep operating The “STDWN” latch.	The high voltage, startup current source turns on to charge $V_{CC}$ . The drive output and the “pfcOK” are in low state (the circuit is off) All the circuit blocks are reset except: The thermal shutdown (TSD) and the brown-out block that keep operating The “STDWN” latch.
$V_{CC}$ goes below $V_{CCRESET}$ ⇒ the circuit resets	The high voltage, startup current source is on. The whole circuitry is reset including the “TSD” and the “STDWN” latch. After reset, the TSD threshold is 150°C and the output of the “STDWN latch” is low.	The high voltage, startup current source is on. The whole circuitry is reset including the “TSD” and the “STDWN” latch. After reset, the TSD threshold is 150°C and the output of the “STDWN latch” is low.

The figures on the following pages portray the circuit behavior during a startup phase:

- In case of normal conditions (Figure 70).
- As a function of the brown-out pin voltage (Figure 71).

## NCP1605, NCP1605A

### Remarks:

[查询"NCP1605DR2G"供应商](#)  
The  $V_{\text{CONTROL}}$  signal does not necessarily reach its clamp level (3.7 V) depending of the load and of the system time constants. In particular, if the circuit starts operation in light load and if the bulk capacitor is not too large, the output voltage  $V_{\text{OUT}}$  generally exceeds the regulation level while  $V_{\text{CONTROL}}$  keeps below its upper limit.

The output voltage exhibits a 100 or 120 Hz ripple (at twice the line frequency). This ripple is also present in the  $V_{\text{CONTROL}}$  voltage even if it is attenuated due to the regulation low bandwidth. Like that of  $V_{\text{OUT}}$ , this ripple is not represented in Figure 70, for the sake of the clarity.

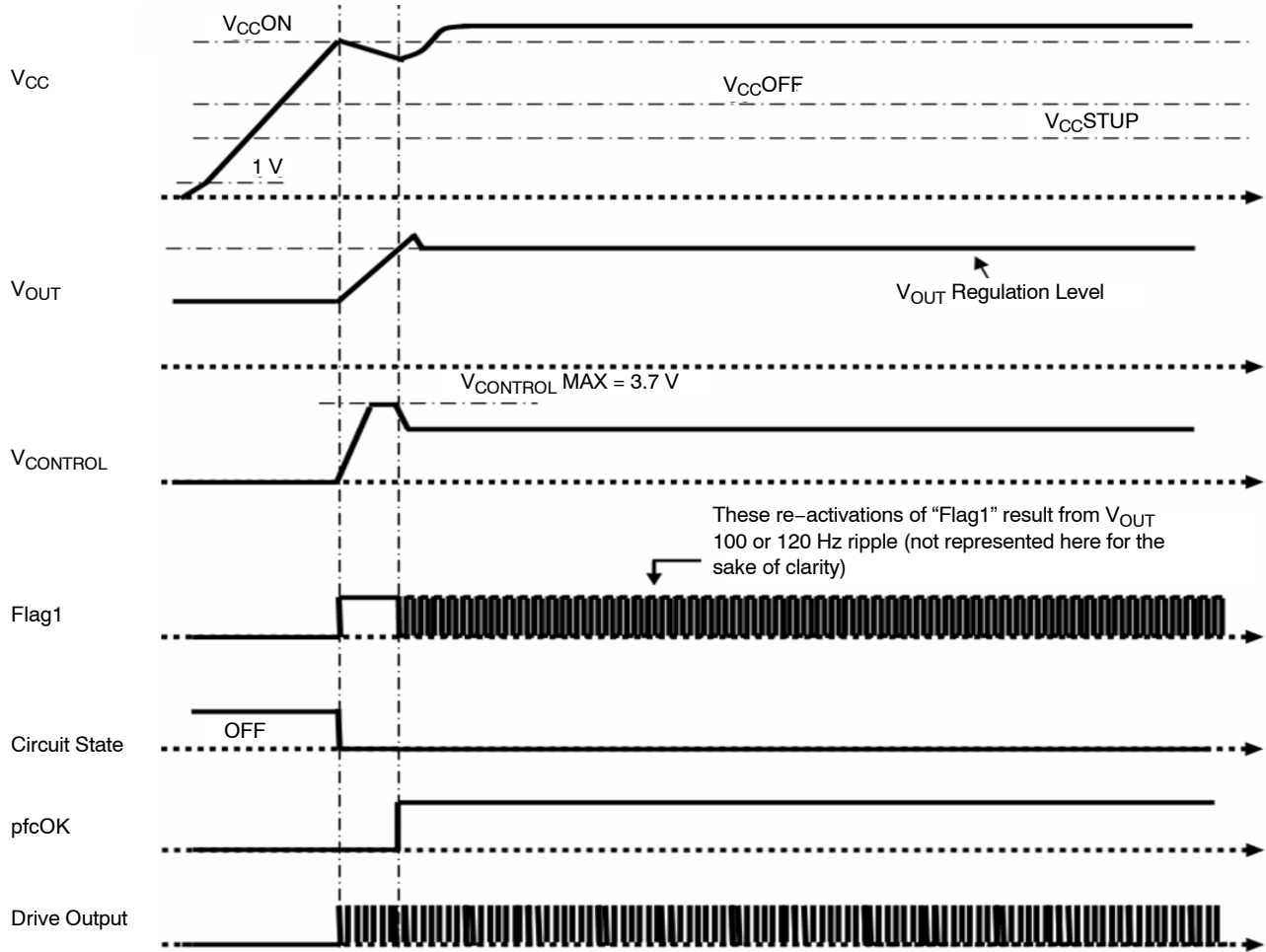
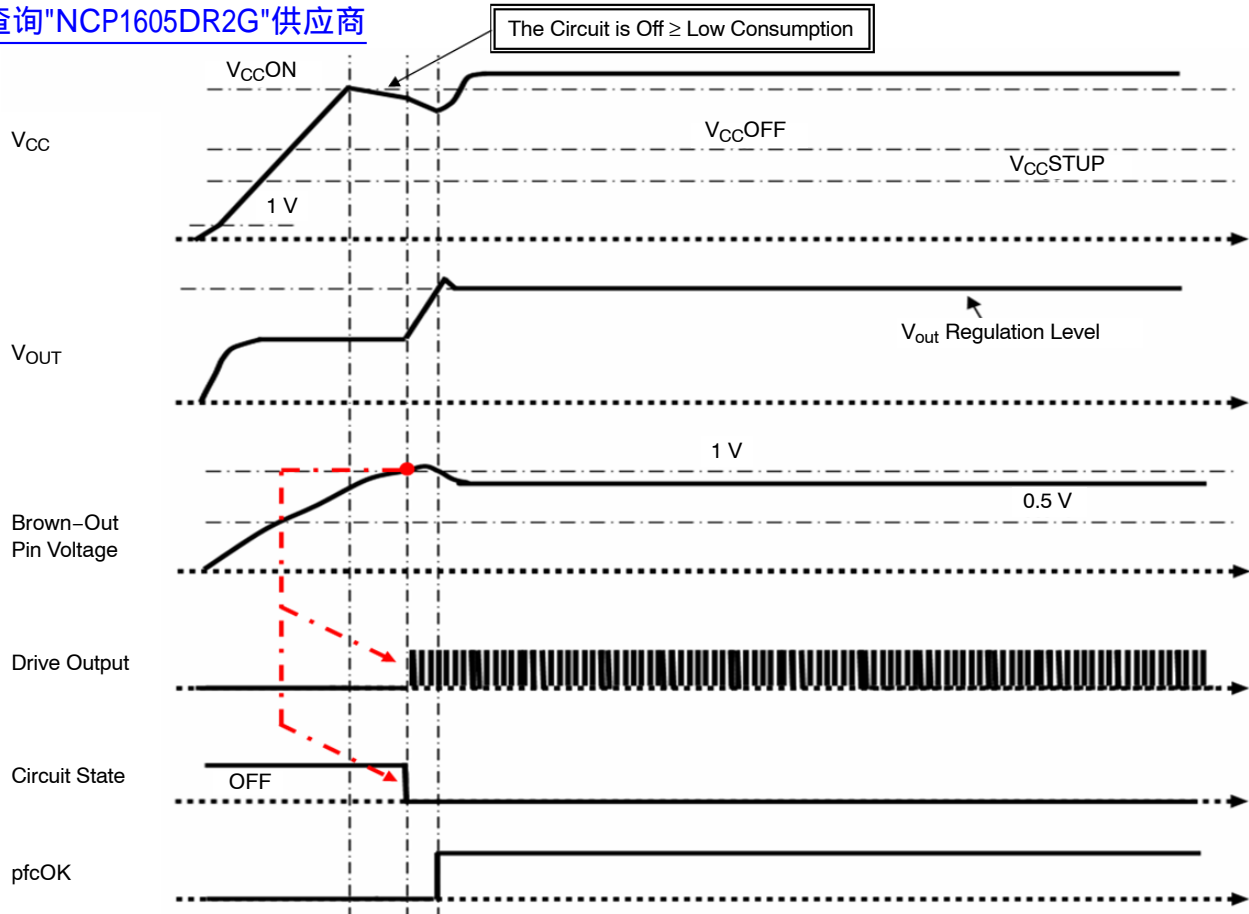


Figure 70. Startup Phase in Normal Conditions

# NCP1605, NCP1605A

[查询"NCP1605DR2G"供应商](#)



**Figure 71. Startup and Brown Out Conditions**

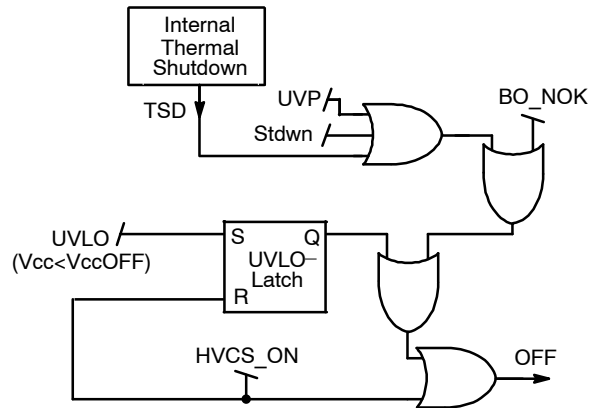
When the high voltage, startup current source is on, the brown-out is active and its threshold is the upper one ( $V_{BO} = V_{BOH} = 1V$ ).

## Fault Management Block

When any of the following faults is detected: brown-out (“BO\_NOK”), Undervoltage (“UVP”), shutdown (“STDWN”), Die Overtemperature (“TSD”), the circuit immediately turns off and recovers operation as soon as the fault disappears.

In case of UVLO ( $V_{CC}$  too low to allow operation), the circuit keeps off until the end of the next  $V_{CC}$  charge phase by the HV startup current source.

The following block diagram details the function.



**Figure 72. Fault Management Block**

[查询"NCP1605DR2G"供应商](#)

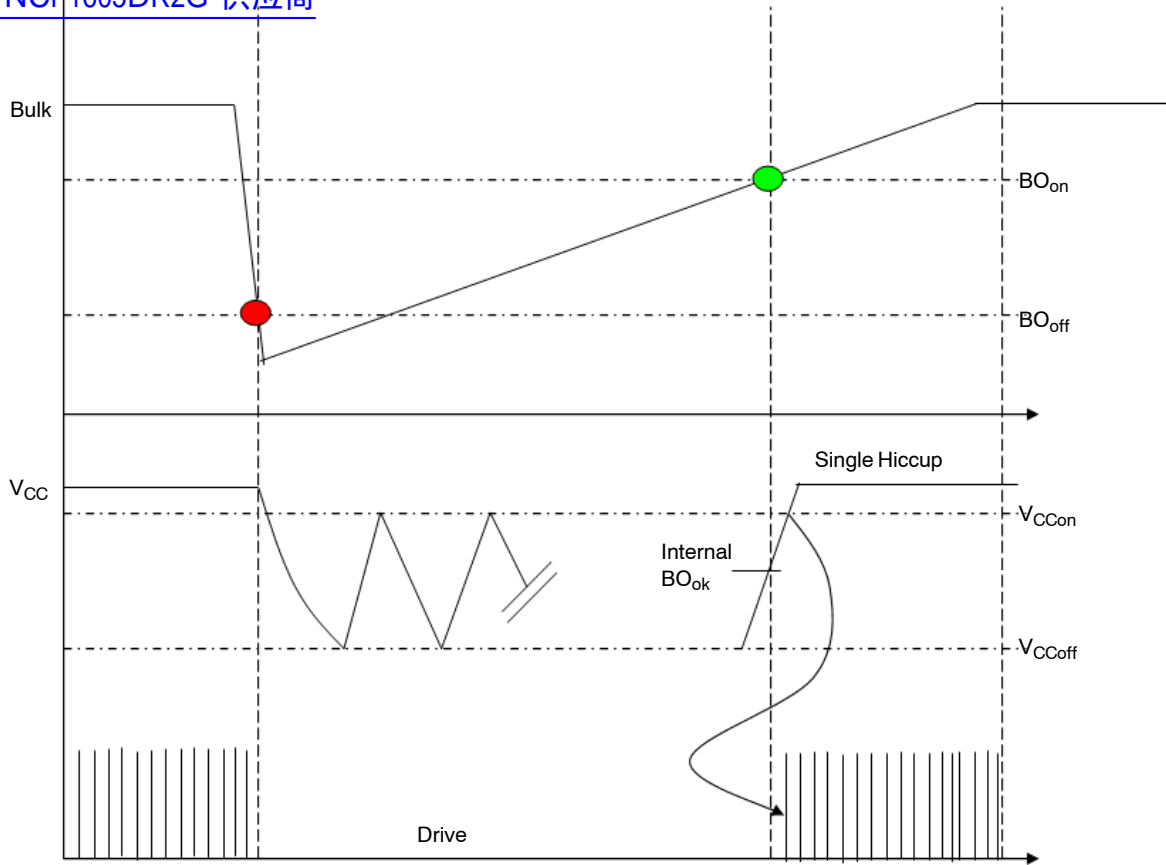


Figure 73.

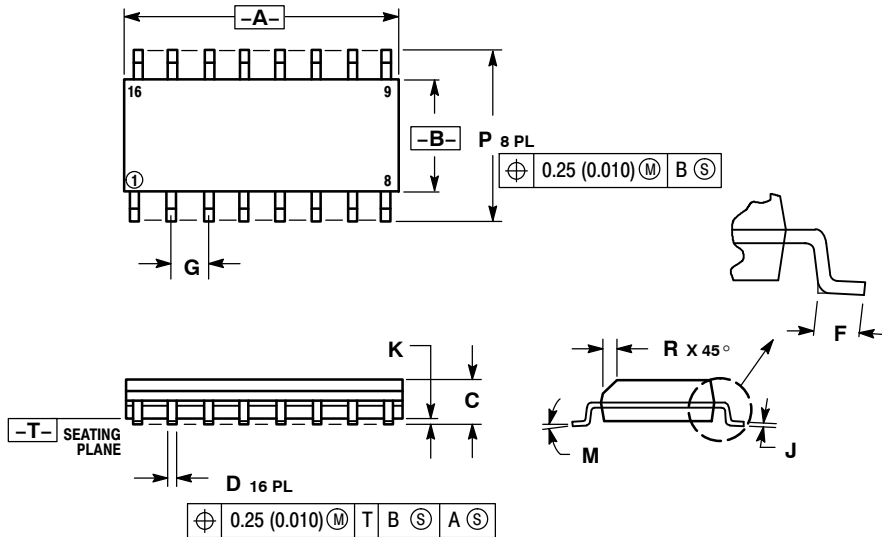
The above figure shows how the circuit recovers after a brown-out event.

# NCP1605, NCP1605A

[查询"NCP1605DR2G"供应商](#)

## PACKAGE DIMENSIONS

SOIC-16  
D SUFFIX  
CASE 751B-05  
ISSUE K

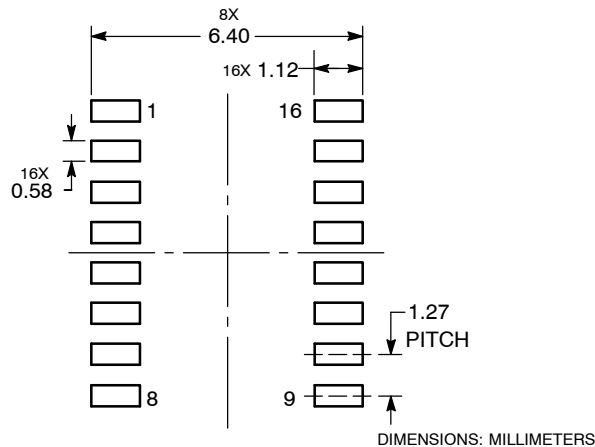


### NOTES:

1. DIMENSIONING AND TOLERANCING PER ANSI Y14.5M, 1982.
2. CONTROLLING DIMENSION: MILLIMETER.
3. DIMENSIONS A AND B DO NOT INCLUDE MOLD PROTRUSION.
4. MAXIMUM MOLD PROTRUSION 0.15 (0.006) PER SIDE.
5. DIMENSION D DOES NOT INCLUDE DAMBAR PROTRUSION. ALLOWABLE DAMBAR PROTRUSION SHALL BE 0.127 (0.005) TOTAL IN EXCESS OF THE D DIMENSION AT MAXIMUM MATERIAL CONDITION.

DIM	MILLIMETERS		INCHES	
	MIN	MAX	MIN	MAX
A	9.80	10.00	0.386	0.393
B	3.80	4.00	0.150	0.157
C	1.35	1.75	0.054	0.068
D	0.35	0.49	0.014	0.019
F	0.40	1.25	0.016	0.049
G	1.27 BSC		0.050 BSC	
J	0.19	0.25	0.008	0.009
K	0.10	0.25	0.004	0.009
M	0°	7°	0°	7°
P	5.80	6.20	0.229	0.244
R	0.25	0.50	0.010	0.019

### SOLDERING FOOTPRINT\*



\*For additional information on our Pb-Free strategy and soldering details, please download the ON Semiconductor Soldering and Mounting Techniques Reference Manual, SOLDERRM/D.

Soft-Skip is a trademark of Semiconductor Components Industries, LLC (SCILLC).

The products described herein, may be covered by the following U.S. patents: 5,502,370 6,271,735, 6,362,067, 6,970,365.

There may be other patents pending

ON Semiconductor and are registered trademarks of Semiconductor Components Industries, LLC (SCILLC). SCILLC reserves the right to make changes without further notice to any products herein. SCILLC makes no warranty, representation or guarantee regarding the suitability of its products for any particular purpose, nor does SCILLC assume any liability arising out of the application or use of any product or circuit, and specifically disclaims any and all liability, including without limitation special, consequential or incidental damages. "Typical" parameters which may be provided in SCILLC data sheets and/or specifications can and do vary in different applications and actual performance may vary over time. All operating parameters, including "Typicals" must be validated for each customer application by customer's technical experts. SCILLC does not convey any license under its patent rights nor the rights of others. SCILLC products are not designed, intended, or authorized for use as components in systems intended for surgical implant into the body, or other applications intended to support or sustain life, or for any other application in which the failure of the SCILLC product could create a situation where personal injury or death may occur. Should Buyer purchase or use SCILLC products for any such unintended or unauthorized application, Buyer shall indemnify and hold SCILLC and its officers, employees, subsidiaries, affiliates, and distributors harmless against all claims, costs, damages, and expenses, and reasonable attorney fees arising out of, directly or indirectly, any claim of personal injury or death associated with such unintended or unauthorized use, even if such claim alleges that SCILLC was negligent regarding the design or manufacture of the part. SCILLC is an Equal Opportunity/Affirmative Action Employer. This literature is subject to all applicable copyright laws and is not for resale in any manner.

### PUBLICATION ORDERING INFORMATION

LITERATURE FULFILLMENT:  
Literature Distribution Center for ON Semiconductor  
P.O. Box 5163, Denver, Colorado 80217 USA  
Phone: 303-675-2175 or 800-344-3860 Toll Free USA/Canada  
Fax: 303-675-2176 or 800-344-3867 Toll Free USA/Canada  
Email: [orderlit@onsemi.com](mailto:orderlit@onsemi.com)

N. American Technical Support: 800-282-9855 Toll Free  
USA/Canada  
Europe, Middle East and Africa Technical Support:  
Phone: 421 33 790 2910  
Japan Customer Focus Center  
Phone: 81-3-5773-3850

ON Semiconductor Website: [www.onsemi.com](http://www.onsemi.com)

Order Literature: <http://www.onsemi.com/orderlit>

For additional information, please contact your local Sales Representative