



查询"3830-102-VIP"供应商: 102-5660 → 702-5841

SANDVIK

Industrial holesaws

Power Driver PD stabilises the sawing operation and distributes efficiently the cutting forces on the saw.

Holesaws can be easily fitted or removed with the Arbor fixed in the power drill.

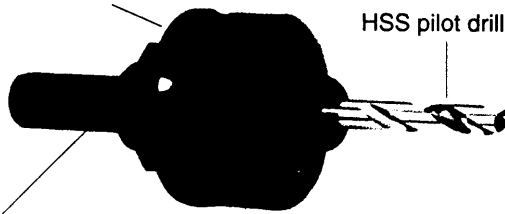

Hardened body for maximum strength

Slots for removal of cores

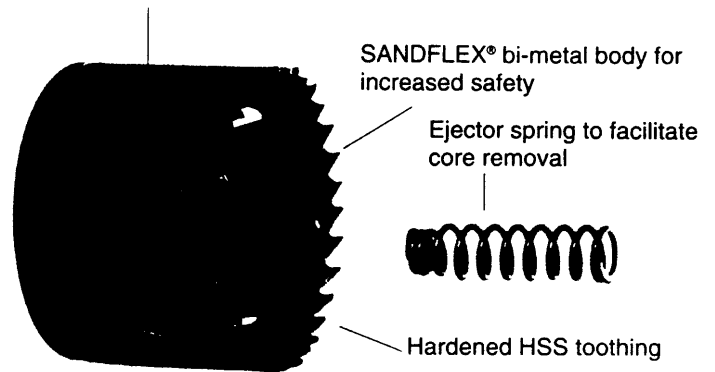

VIP holesaws for exacting applications

Sandvik's VIP holesaws have a 4/6 tooth shape. By varying the distance between the teeth (vari-pitch) a smoother cut is achieved with less vibration, even in difficult-to-cut materials. The aggressive tooth shape cuts fast, whilst the large tooth gullets and large tooth set make swarf removal more efficient.

All VIP holesaws are manufactured from SANDFLEX bi-metal steel with hardened teeth of high alloyed high-speed steel (HSS). Bi-metal gives increased safety as it will not shatter if overloaded. It enables the highest cutting performance in all machinable materials from wood to stainless steel, and it gives increased resistance to wear.

All Sandvik's holesaws

- 38 mm (1 1/2") cutting depth.
- Solid, flat cap design to withstand heavy workload.
- All sizes are in millimeters.

The following are general points regarding the use of Sandvik hole saws.

- Clamp the workpiece firmly.
- **Selection of arbor** - Select the proper arbor for the hole saw size and your power drill. If the arbor has drive pins, make sure they are engaged.
For arbors with drive pins, slide pin ring back, screw hole saw onto arbor to shoulder, and push ring with pins into hole saw while backing off hole saw if necessary.
- Maintain positive feed rate, but exercise care not to abruptly feed saw into work. Always start operation perpendicular to the workpiece.
- **Removal of chips** - is extremely important. Intermittent withdrawal of holesaw is recommended to prevent clogging in the gullet area.
- **Operation speeds (RPM)** - The cutting speeds recommended in the table are intended as a general guide. Your experience may show that the variations from these general recommendations ensure better performance.

Carbide tipped holesaws a new member of the holesaw family.

On our new carbide tipped holesaws the tooth tips consist of a carbide "round rod" which is fusion welded to the back material. The tip is then ground to its final shape with 5 degrees positive cutting angle.

CT holesaws open new possibilities to cut holes in materials such as light concrete, brick, tile, reinforced plastics and other abrasive non-ferrous materials.

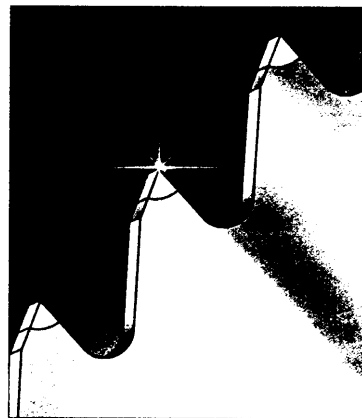

Carbide tipped hole saws are **not** recommended for cutting ferrous materials (steel).

- Use pilot drill DRL-1 in thin material up 5 mm and DRL-2 in thicker materials.
- Always use a lubricant when sawing in metal. It gives better performance and prolongs the life of the holesaw.
- A water coolant may be helpful when cutting ceramic tile. Plenty of water might be necessary.
- Use an arbor with a carbide tipped pilot drill when cutting ceramic tile, firebrick and other abrasive materials.
- When cutting fibreglass, glass reinforced plastics, bakelite and similar materials, reduce speed so that materials do not soften or clog the gullets of the saw.



Nothing more and nothing less but perfect holes from 14 to 152 mm

This is our complete tool range, from arbors and pilot drills to holesaws, with both conventional bi-metal tools and our new carbide tipped saws. Saw depth (material thickness) is up to 38 mm. We have introduced arbors with SD drive shanks. These arbors are designed for machines with quick chucks (Hilti and Bosch). They eliminate the need to change machine for work with holesaws.

Standard arbor assortment

Arbors without drive pins for low and medium sawing forces.

All small arbors are supplied with a pilot drill (DRL-1), designed for thinner materials. Drills DRL-1 and DRL-2 fit all arbors.

630



930



With extra deep pilot drill hole for adjusting how far the drill protrudes.

1130



Arbors 630, 930 and 1130 are identical except for the shank, which is designed for use with different chuck sizes. All small arbors are supplied with a pilot drill (DRL-1) which is designed for drilling in thin materials.

9100



Arbors 9100, 11152 and 16152 are identical except for the shank, which is designed for used with different chuck sizes. The amount the drill protrudes can be adjusted in all arbors with drive pins.

11152



16152



3834-EXT-2



3834-EXT-1



Extensions

For improved access when sawing in difficult conditions. Manufactured from high-grade hardened steel.

3834-MRS-2

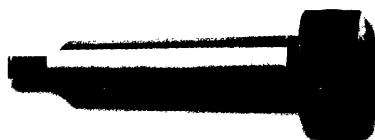

3834-MRS-3-11

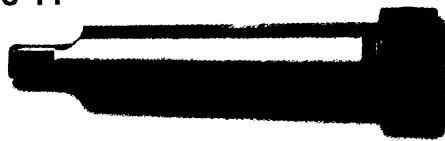

3834-MRS-3



Morse taper adaptors

For the hexagonal arbor drive shank when using holesaws in pillar drilling machines.

Arbors with drive pins for larger sawing force.

All large arbors are supplied with a pilot drill (DRL-2) which is designed for thicker materials. Drills DRL-1 and DRL-2 fit all arbors.

The new arbor design from Sandvik,

the Power Driver (patent pending) eliminate play. It increases the strength of the holesaw by redistributing the load from the thread to the solid cap. To be used with hand held machines and when operating with high work load in stationary machines.



查询"3830-102-VIP"供应商

Special arbor assortment

SD30



730



With triangular shank, stronger than arbor 630.

ADP

makes it possible to use small arbors for large holesaws (not over 44 mm).

ES

Ejector spring fits all arbor drills and makes it easier to remove the core.



11152QC

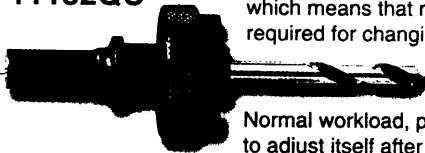

A lightweight quick change arbor which means that no tools are required for changing the saw.

Normal workload, play allow holesaw to adjust itself after the workpiece.

DRL-CT

Drill for use together with our new carbide tipped holesaws.

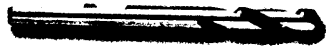

DRL-2-SS

Drill with tip for drilling in stainless steel.



SD152QC

A quick change arbor with SD shank to make it ease to change holesaws and to remove the arbor from the machine without the use of tools.

Bi-metal holesaws

Carbide tipped holesaws

1/2"-20 UNF



ø 14-30 mm



5/8"-18 UNF



ø 32-35 mm



ø 37-73 mm

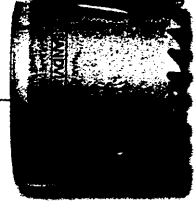

Drive plate 3834-DP-75



ø 76-105 mm

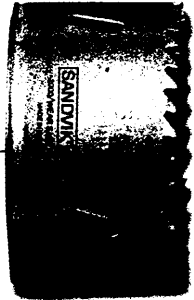

3834-DP-100

For high work load when using other arbors than the Power Driver.



ø 108-162 mm

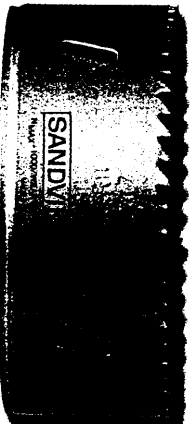



HOLESAWS



SANDVIK

查询"3830-102-VIP"供应商

When sawing in thick and difficult-to-cut materials, it may help to drill a few holes in the periphery of the circle, which greatly facilitates swarf removal.

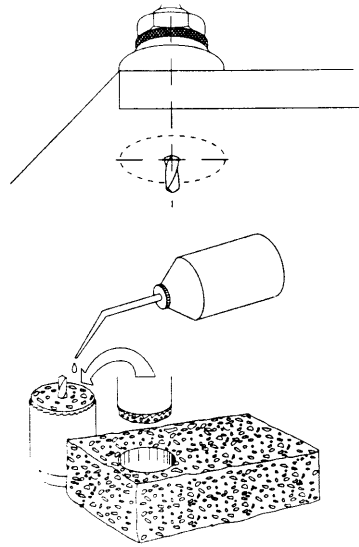
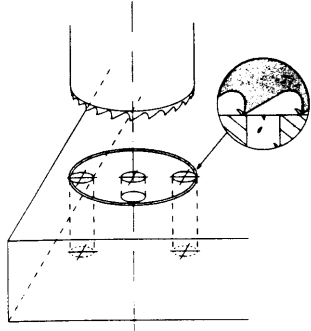

When sawing in wood finish off the sawing operation from the reverse side to avoid splinters.

Place an oil-imbibed sponge in the holesaw if you

- cannot lubricate normally.
- are sawing in stainless steel.
- are sawing in a difficult-to-reach position (e.g. from underneath the material)

You may use your holesaw to manufacture your own sponge. Saw into a normal car sponge without using the pilot drill. Engage this afterwards.

Operating speeds VIP holesaws

Size MM	Size INCH	Mild steel	Cast iron	Tool and stainless steel	Brass	Alum-inium	Wood
14	9/16	580	400	300	790	900	3000
16	5/8	550	365	275	730	825	3000
17	11/16	500	330	250	665	750	3000
19	3/4	460	300	230	600	690	3000
20	25/32	440	290	220	580	660	3000
21	13/16	425	280	210	560	635	3000
22	7/8	390	260	195	520	585	3000
24	15/16	370	245	185	495	555	3000
25	1	350	235	175	470	525	2700
27	1 1/16	325	215	160	435	480	2700
29	1 1/8	300	200	150	400	450	2700
30	1 3/16	285	190	145	380	425	2400
32	1 1/4	275	180	140	380	410	2400
33	1 5/16	260	175	135	345	390	2400
35	1 3/8	250	165	125	330	375	2400
37	1 7/16	240	160	120	315	360	2400
38	1 1/2	230	150	115	300	345	2400
40	1 9/16	220	145	110	290	330	2100
41	1 5/8	210	140	105	280	315	2100
43	1 11/16	205	135	100	270	305	2100
44	1	195	130	95	260	295	2100
46	1 13/16	190	125	95	259	285	2100
48	1 7/8	180	120	90	240	270	2100
51	2	170	115	85	230	255	2000
52	2 1/16	165	110	80	220	245	2000
54	2 1/8	160	105	80	210	240	2000
56	2 7/32	150	100	75	200	225	2000
57	2	150	100	75	200	225	2000
59	2 5/16	145	100	75	195	225	2000
60	2 3/8	140	95	70	190	220	2000
64	2 1/2	135	90	65	180	205	1800
65	2 9/16	130	85	65	175	200	1800
67	2 5/8	130	85	65	170	195	1800
68	2 11/16	130	85	65	170	195	1800
70	2	125	80	60	160	185	1800
73	2 7/8	120	80	60	160	180	1800
76	3	115	75	55	150	170	1800
79	3 1/8	110	70	55	140	165	1500
83	3	105	70	50	140	155	1500
86	3 3/8	100	65	50	130	150	1500
89	3 1/2	95	65	45	130	145	1200
92	3 5/8	95	60	45	120	140	1200
95	3	90	60	45	120	135	1200
98	3 7/8	90	60	45	120	135	1200
102	4	85	55	40	110	130	1000
105	4 1/8	80	55	40	110	120	1000
108	4	80	55	40	110	120	900
111	4 3/8	80	50	40	100	120	900
114	4 1/2	75	50	35	100	105	900
121	4	75	50	35	95	95	900
127	5	65	45	30	90	90	800
133	5	60	40	25	85	85	800
140	5 1/2	60	40	25	85	85	800
146	5	55	35	25	75	75	800
152	6	55	35	25	75	75	800
168	6 5/8	50	35	25	65	75	700
177	7	45	35	25	65	75	700
210	8 1/4	40	25	20	55	60	500

Operating speeds CT holesaws

Size MM	Size INCH	Fire brick Ceramic tile	Soft brick Slate	Ply-wood	Fibre glass	Bake-lite	Hard Wood
14	9/16	680	1705	3400	2380	1030	1360
16	5/8	610	1535	3060	2140	930	1220
17	11/16	560	1395	2785	1950	850	1110
19	3/4	510	1280	2550	1790	770	1020
20	25/32	480	1210	2430	1700	730	970
21	13/16	470	1180	2355	1650	710	940
22	7/8	430	1095	2180	1530	660	870
24	15/16	410	1020	2040	1430	620	810
25	1	380	960	1920	1340	580	760
27	1 1/16	360	900	1800	1260	550	720
29	1 1/8	340	850	1700	1190	510	680
30	1 3/16	320	810	1610	1130	490	640
32	1 1/4	310	770	1530	1070	460	610
33	1 5/16	290	730	1460	1020	440	580
35	1 3/8	280	700	1390	980	420	550
37	1 7/16	270	670	1330	930	400	530
38	1 1/2	260	640	1280	890	390	510
40	1 9/16	240	615	1220	860	370	490
41	1 5/8	235	590	1180	820	360	470
43	1 11/16	230	570	1130	790	340	450
44	1	220	550	1100	770	330	430
46	1 13/16	210	530	1060	740	320	420
48	1 7/8	205	510	1020	710	310	410
51	2	190	480	960	670	290	380
52	2 1/16	185	465	930	650	280	370
54	2 1/8	180	450	900	630	270	360
56	2 7/32	175	435	870	610	265	345
57	2	170	430	850	600	260	340
59	2 5/16	165	415	830	580	250	330
60	2 3/8	160	405	810	560	240	320
64	2 1/2	150	380	760	540	230	310
65	2 9/16	148	370	750	530	225	300
67	2 5/8	145	365	730	510	220	290
68	2 11/16	142	360	720	500	215	285
70	2	140	350	700	490	210	280
73	2 7/8	135	330	670	470	200	270
73	3	130	320	640	450	190	260
79	3 1/8	125	310	610	430	185	250
83	3	120	295	590	410	180	240
86	3 3/8	115	285	570	400	170	230
89	3 1/2	110	270	550	380	165	220
92	3 5/8	105	260	530	370	160	210
95	3	100	255	510	360	155	200
98	3 7/8	98	250	490	350	150	195
102	4	95	240	480	330	145	190
105	4 1/8	92	235	460	320	140	185
108	4	90	230	450	310	135	180
111	4 3/8	87	220	440	300	130	175
114	4 1/2	85	210	420	290	128	170
121	4	80	200	400	280	120	160
127	5	75	190	380	270	110	150
133	5	72	180	365	255	105	145
140	5 1/2	70	170	350	240	100	140
146	5	67	165	335	230	95	135
152	6	65	160	320	220	90	130

Sales, Marketing &
Administration Centre
Canal Road, Leeds
LS12 2TU
United Kingdom

[查询"3830-102-VIP"供应商](#)



fax header

To: Winnie Tam From: Sue Green
Company: YEE SING Our Fax: 0113 279 4449
Your Fax:
No. of pages: Date: 3 Jan

Message:

In response to your request for faxed copies of data sheet(s), we wish to advise as follows:

<u>TYPE NUMBERS</u>	<u>CODE</u>	<u>TYPE NUMBERS</u>	<u>CODE</u>
702-5060-584	A
702 6018-6048	A
.....

CODE

- A = The full data sheet follows this page
B = Relevant parameters follow this page. A copy of the full data sheet will be posted to you today

Please do not hesitate to contact us if we can be of further assistance

Best Regards

Sue Green

Senior Technical Data Assistant – Farnell
Global distributor of electronic, electrical and industrial components
Greens@farnell.com

Tel 0113 279 0101 ext 4804

Sales	Administration	Export
Tel 0870 1200 200	Tel 0870 122 7711	Tel +44 870 1200 208
Fax 0870 1200 201	Fax 0870 1200 201	Fax +44 870 1200 209
Marketing & Purchasing	Technical Support	Internet
Tel 0870 122 7711	Tel 0870 1200 202	http://www.farnell.com
Fax 0113 263 3404	Fax 0870 1200 203	



Registered in England No. 439733. Registered Office: Farnell Electronic Components Ltd.,
Farnell House, Forge Lane, Leeds LS12 2NE. A Premier Farnell company



**SANDFLEX®
Bi-metal**

Our SANDFLEX holesaws work excellently in most materials such as wood, steel and metal. Fit all power drills, both stationary and portable. Knockout holes allow easy removal of cores. Cutting depth max.38 mm (1 1/2") 4/6 teeth per inch.

Pipe ø inch - clearance hole mm: e.g. 2"- 64 mm. Diameter mm - Nominal holesaw size. Max. holesize +1,5 mm./ - 0,0

3830-VIP

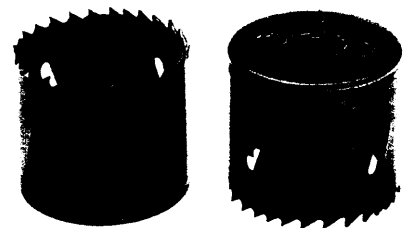
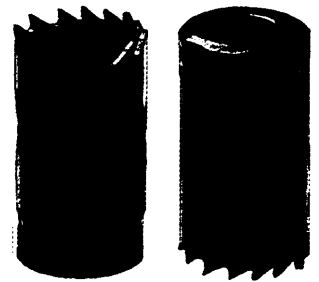
Product code	EAN code 731151+		Diameter		Pipe ø inch	
			mm	inch		
3830-14-VIP	8041618	1	14	9/16	1/4	20
3830-16-VIP	8041625	1	16	5/8		20
3830-17-VIP	8041632	1	17	11/16		30
3830-19-VIP	8041649	1	19	3/4	3/8	30
3830-20-VIP	8041656	1	20	25/32		30
3830-21-VIP	8041663	1	21	13/16		40
3830-22-VIP	8041670	1	22	7/8	1/2	40
3830-24-VIP	8041687	1	24	15/16		55
3830-25-VIP	8041694	1	25	1		55
3830-27-VIP	8041700	1	27	1 1/16		70
3830-29-VIP	8041717	1	29	1 1/8	3/4	70
3830-30-VIP	8041724	1	30	1 3/16		70
3830-32-VIP	8041731	1	32	1 1/4		70
3830-33-VIP	8041748	1	33	1 5/16		70
3830-35-VIP	8041755	1	35	1 3/8	1	70
3830-37-VIP	8041762	1	37	1 7/16		80
3830-38-VIP	8041779	1	38	1 1/2		80
3830-40-VIP	8041786	1	40	1 9/16		80
3830-41-VIP	8041793	1	41	1 5/8		80
3830-43-VIP	8041809	1	43	1 11/16		90
3830-44-VIP	8041816	1	44	1 3/4	1 1/4	100
3830-46-VIP	8041823	1	46	1 13/16		100
3830-48-VIP	8041830	1	48	1 7/8		100
3830-51-VIP	8041847	1	51	2	1 1/2	120
3830-52-VIP	8041854	1	52	2 1/16		120
3830-54-VIP	8041861	1	54	2 1/8		140
3830-56-VIP	8152703	1	56	2 3/16		140
3830-57-VIP	8041878	1	57	2 1/4		140
3830-59-VIP	8041885	1	59	2 5/16		140
3830-60-VIP	8041892	1	60	2 3/8		160
3830-64-VIP	8041908	1	64	2 1/2	2	180
3830-65-VIP	8041915	1	65	2 9/16		180
3830-67-VIP	8041922	1	67	2 5/8		200
3830-68-VIP	8196530	1	68	2 11/16		220
3830-70-VIP	8041939	1	70	2 3/4		220
3830-73-VIP	8041946	1	73	2 7/8		220
3830-76-VIP	8041953	1	76	3		240
3830-79-VIP	8041960	1	79	3 1/8	2 1/2	260
3830-83-VIP	8041977	1	83	3 1/4		260
3830-86-VIP	8041984	1	86	3 3/8		260
3830-89-VIP	8041991	1	89	3 1/2		270
3830-92-VIP	8042004	1	92	3 5/8	3	270
3830-95-VIP	8042011	1	95	3 3/4		270
3830-98-VIP	8042028	1	98	3 7/8		300
3830-102-VIP	8042035	1	102	4		320
3830-105-VIP	8042042	1	105	4 1/8	3 1/2	320





Continued...

SANDFLEX®
3i-metal

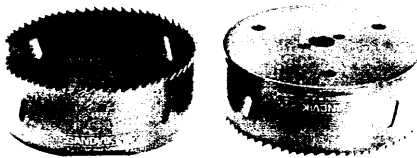
Our SANDFLEX holesaws work excellently in most materials such as wood, steel and metal. Fit all power drills, both stationary and portable. Knockout holes allow easy removal of cores. Cutting depth max. 38 mm (1 1/2") 4/6 teeth per inch.
 Pipe ø inch - clearance hole mm: e.g. 2"- 64 mm. Diameter mm - Nominal holesaw size. Max. holesize +1,5 mm./ - 0,0

3830-VIP

Product code	EAN code 731151+		Diameter		Pipe ø inch	
			mm	inch		
...Continued						
3830-108-VIP	8042059	1	108	4 1/4		350
3830-111-VIP	8042066	1	111	4 3/8		350
3830-114-VIP	8042073	1	114	4 1/2	4	360
3830-121-VIP	8042080	1	121	4 3/4		410
3830-127-VIP	8042097	1	127	5		520
3830-133-VIP	8042103	1	133	5 1/4		560
3830-140-VIP	8042110	1	140	5 1/2		560
3830-146-VIP	8042127	1	146	5 3/4	5	570
3830-152-VIP	8042134	1	152	6		610

Extra large sizes.

168 mm and 210 mm 6 TPI (R6). Cutting depth max. 38 mm. 177 mm 4/6 TPI. Cutting depth max 50 mm.

All large holesaws cut with 0 degree cutting angle to be less aggressive.

3830-168	8040659	1	168	6 5/8	6	650
3830-177-HIGH	8101329	1	177	7		1340
3830-210	8040666	1	210	8 1/4		750

3830-BL

Retail packaging, clam shell.

3830-16BL	8041106	1	16	5/8		20
3830-19BL	8041113	1	19	3/4		30
3830-20BL	8041120	1	20	25/32		30
3830-22BL	8041137	1	22	7/8		40
3830-25BL	8041144	1	25	1		55
3830-29BL	8041151	1	29	1 1/8		70
3830-30BL	8041168	1	30	1 3/16		70
3830-32BL	8041175	1	32	1 1/4		70
3830-35BL	8041182	1	35	1 3/8		70
3830-38BL	8041199	1	38	1 1/2		80
3830-41BL	8041205	1	41	1 5/8		80
3830-44BL	8041212	1	44	1 3/4		100
3830-48BL	8046552	1	48	1 7/8		100
3830-51BL	8041229	1	51	2		120
3830-54BL	8046569	1	54	2 1/8		140
3830-57BL	8041236	1	57	2 1/2		140
3830-60BL	8046576	1	60	2 3/8		160
3830-64BL	8041243	1	64	2 1/2		180
3830-70BL	8041250	1	70	2 3/4		220
3830-76BL	8041267	1	76	3		240

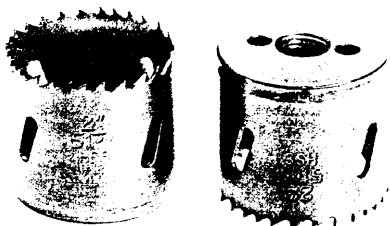



[查询"3830-102-VIP"供应商](#)

SANDVIK

Our Carbide Tipped holesaws work excellently in everything from brick and tile to such things as reinforced plastic. Fit all power drills, both stationary and portable. Knockout holes allow easy removal of cores. Cutting depth 38 mm (1 1/2"), ground teeth, 4 teeth per inch.

Holesaw Carbide tipped

Product code	EAN code 731151+		Ø mm	
3832-14	8557744	1	14	20
3832-16	8557768	1	16	20
3832-17	8557782	1	17	30
3832-19	8557805	1	19	30
3832-20	8557812	1	20	30
3832-21	8557829	1	21	40
3832-22	8557843	1	22	40
3832-24	8557867	1	24	55
3832-25	8557881	1	25	55
3832-27	8557904	1	27	70
3832-29	8557928	1	29	70
3832-30	8557942	1	30	70
3832-32	8557966	1	32	70
3832-33	8557980	1	33	70
3832-35	8558000	1	35	70
3832-37	8558024	1	37	80
3832-38	8558048	1	38	80
3832-40	8558062	1	40	80
3832-41	8558086	1	41	80
3832-43	8558109	1	43	90
3832-44	8558123	1	44	100
3832-46	8558147	1	46	100
3832-48	8558161	1	48	100
3832-51	8558185	1	51	120
3832-52	8558208	1	52	120
3832-54	8558222	1	54	140
3832-56	8558239	1	56	140
3832-57	8558246	1	57	140
3832-59	8558260	1	59	140
3832-60	8558284	1	60	160
3832-64	8558307	1	64	180
3832-65	8558321	1	65	180
3832-67	8558345	1	67	200
3832-68	8558352	1	68	220
3832-70	8558369	1	70	220
3832-73	8558383	1	73	220
3832-76	8558406	1	76	240
3832-79	8558420	1	79	260
3832-83	8558444	1	83	260
3832-86	8558468	1	86	260
3832-89	8558482	1	89	270
3832-92	8558505	1	92	270
3832-95	8558529	1	95	270
3832-98	8558543	1	98	300
3832-102	8558567	1	102	320
3832-105	8558581	1	105	320
3832-108	8558604	1	108	350
3832-111	8558611	1	111	350
3832-114	8558628	1	114	360
3832-121	8558642	1	121	410
3832-127	8558666	1	127	520
3832-133	8558673	1	133	560
3832-140	8558680	1	140	560
3832-146	8558697	1	146	570
3832-152	8558703	1	152	610

3832

