



**ISO176**

## Precision, Isolated OPERATIONAL AMPLIFIER

### FEATURES

- **RATED**  
1500Vrms Continuous  
2500Vrms for One Minute  
100% TESTED FOR PARTIAL DISCHARGE
- **HIGH IMR: 115dB at 50Hz**
- **LOW NONLINEARITY:  $\pm 0.05\%$**
- **LOW INPUT BIAS CURRENT:  $\pm 5\text{nA max}$**
- **LOW INPUT OFFSET VOLTAGE:  $\pm 20\mu\text{V}$**
- **OP AMP INPUTS PROTECTED TO  $\pm 30\text{V}$**
- **MOD INPUT PROTECTED TO  $\pm 100\text{V}$**
- **BIPOLAR OPERATION:  $V_O = \pm 10\text{V}$**
- **SYNCHRONIZATION CAPABILITY**
- **24-PIN PLASTIC DIP: 0.3" Wide**

### APPLICATIONS

- **INDUSTRIAL PROCESS CONTROL**  
Transducer Isolator, Thermocouple Isolator, RTD Isolator, Pressure Bridge Isolator, Flow Meter Isolator
- **POWER MONITORING**
- **MEDICAL INSTRUMENTATION**
- **ANALYTICAL MEASUREMENTS**
- **BIOMEDICAL MEASUREMENTS**
- **DATA ACQUISITION**
- **TEST EQUIPMENT**
- **POWER MONITORING**
- **GROUND LOOP ELIMINATION**

### DESCRIPTION

ISO176 is a precision isolation amplifier incorporating an uncommitted operational amplifier for input conditioning, a novel duty cycle modulation-demodulation technique and excellent accuracy. Internal input protection can withstand up to  $\pm 30\text{V}$  differential without damage. The signal is transmitted digitally across a differential capacitive barrier. With digital modulation the barrier characteristics do not affect signal integrity. This results in excellent reliability and good high frequency transient immunity across the barrier. Both the amplifier and barrier capacitors are housed in a plastic DIP.

ISO176 is easy to use. No external components are required. A power supply range of  $\pm 4.5\text{V}$  to  $\pm 18\text{V}$  makes this amplifier ideal for a wide range of applications.

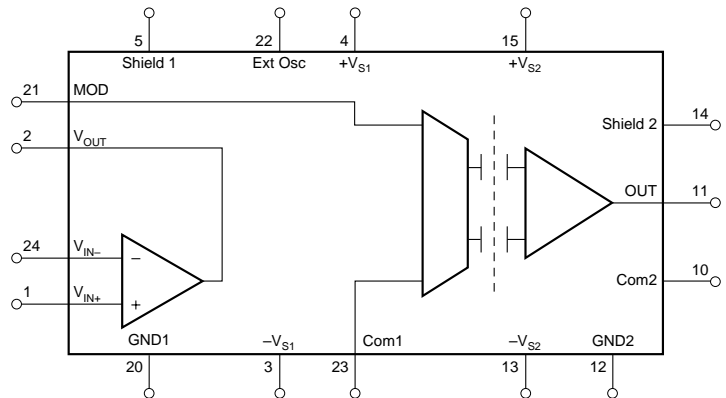

# SPECIFICATIONS

查询ISO176 供应商

At  $T_A = +25^\circ\text{C}$ ,  $V_{S1} = V_{S2} = \pm 15\text{V}$ , and  $R_L = 2\text{k}\Omega$  unless otherwise noted.

PARAMETER	CONDITIONS	ISO176P			UNITS
		MIN	TYP	MAX	
<b>ISOLATION<sup>(1)</sup></b> Voltage Rated Continuous: AC DC 100% Test (AC, 50Hz) Isolation-Mode Rejection AC 50Hz DC Barrier Impedance Leakage Current	$T_{\text{MIN}}$ to $T_{\text{MAX}}$ $T_{\text{MIN}}$ to $T_{\text{MAX}}$ 1s; Partial Discharge $\leq 5\text{pC}$  1500Vrms  $V_{\text{ISO}} = 240\text{Vrms}, 50\text{Hz}$	1500 2121 2500	115 160 $10^{14} \parallel 6$ 0.8	1	Vrms VDC Vrms  dB dB $\Omega \parallel \text{pF}$ $\mu\text{Arms}$
<b>ISO AMP - GAIN</b> Gain Error <sup>(2)</sup> Gain vs Temperature Nonlinearity	G = 1 G = 1 G = 1		$\pm 0.05$ $\pm 10$	$\pm 0.102$	%FSR ppm/ $^\circ\text{C}$ %
<b>ISO AMP - OFFSET VOLTAGE</b> Offset vs Temperature vs Supply			$\pm 500$ $\pm 2$	100	mV $\mu\text{V}/^\circ\text{C}$ $\mu\text{V/V}$
<b>ISO AMP - INPUT</b> Input Resistance			200		k $\Omega$
<b>ISO AMP - OUTPUT</b> Voltage Range Current Drive Capacitive Load Drive Ripple Voltage		$\pm 10$ $\pm 5$	0.1 10		V mA $\mu\text{F}$ mVp-p
<b>OP AMP - INPUT</b> Voltage Range Bias Current vs Temperature Offset Voltage Offset Current vs Temperature			$\pm 13$  $\pm 15$ $\pm 20$  $\pm 1.5$	$\pm 5$   $\pm 5$	V nA pA/ $^\circ\text{C}$ $\mu\text{V}$ nA pA/ $^\circ\text{C}$
<b>FREQUENCY RESPONSE</b> Small Signal Bandwidth  Slew Rate	100mV, G = 1 100mV, G = 10 100mV, G = 100 $V_O = \pm 10\text{V}, G = 10$		60 60 60 0.3		kHz kHz kHz V/ $\mu\text{s}$
<b>POWER SUPPLIES</b> Rated Voltage Voltage Range Quiescent Current $V_{\text{CC1}}$ $V_{\text{CC2}}$		$\pm 4.5$	15  9 7.5	$\pm 18$	V V mA mA
<b>TEMPERATURE RANGE</b> Operating Storage		-40 -40		85 125	$^\circ\text{C}$ $^\circ\text{C}$

NOTE: (1) All devices receive a 1s test. Failure criterion is  $\geq 5$  pulses of  $\geq 5\text{pX}$ . (2) Tested as a OPA and ISO, max  $\pm 0.35\%$  FSR.

The information provided herein is believed to be reliable; however, BURR-BROWN assumes no responsibility for inaccuracies or omissions. BURR-BROWN assumes no responsibility for the use of this information, and all use of such information shall be entirely at the user's own risk. Prices and specifications are subject to change without notice. No patent rights or licenses to any of the circuits described herein are implied or granted to any third party. BURR-BROWN does not authorize or warrant any BURR-BROWN product for use in life support devices and/or systems.

### ABSOLUTE MAXIMUM RATINGS

Supply Voltage .....	±18V
Op Amp Analog Input Voltage Range .....	±V <sub>S1</sub>
External Oscillator Input .....	±25V
Signal Common 1 to Ground 1 .....	±1V
Signal Common 2 to Ground 2 .....	±1V
Continuous Isolation Voltage: .....	1500Vrms
IMV, dv/dt .....	20kV/μs
Junction Temperature .....	150°C
Storage Temperature .....	-40°C to +125°C
Lead Temperature (soldering, 10s) .....	+300°C
Output Short Duration .....	Continuous to Common
MOD Input Voltage Range .....	±100V



### ELECTROSTATIC DISCHARGE SENSITIVITY

Any integrated circuit can be damaged by ESD. Burr-Brown recommends that all integrated circuits be handled with appropriate precautions. Failure to observe proper handling and installation procedures can cause damage.

ESD damage can range from subtle performance degradation to complete device failure. Precision integrated circuits may be more susceptible to damage because very small parametric changes could cause the device not to meet published specifications.

### PIN CONFIGURATION

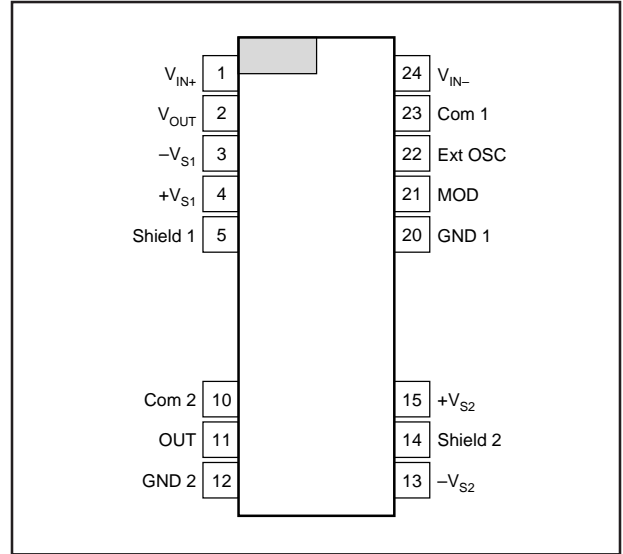

### PACKAGE/ORDERING INFORMATION

PRODUCT	PACKAGE	PACKAGE DRAWING NUMBER <sup>(1)</sup>	BANDWIDTH
ISO176P	24-Pin Plastic DIP	243-2	60kHz

NOTE: (1) For detailed drawing and dimension table, please see end of data sheet, or Appendix C of Burr-Brown IC Data Book.

# TYPICAL PERFORMANCE CURVES (CONT)

[查询 ISO176 供应商](#)

At  $T_A = +25^\circ\text{C}$ ,  $V_{S1} = V_{S2} = \pm 15\text{V}$ , and  $R_L = 2\text{k}\Omega$ , unless otherwise noted.

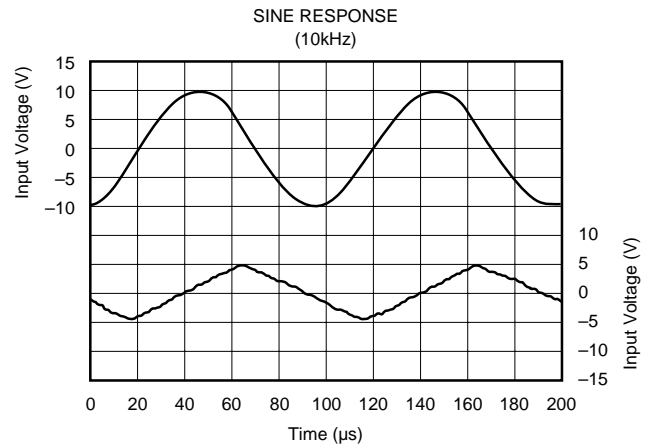
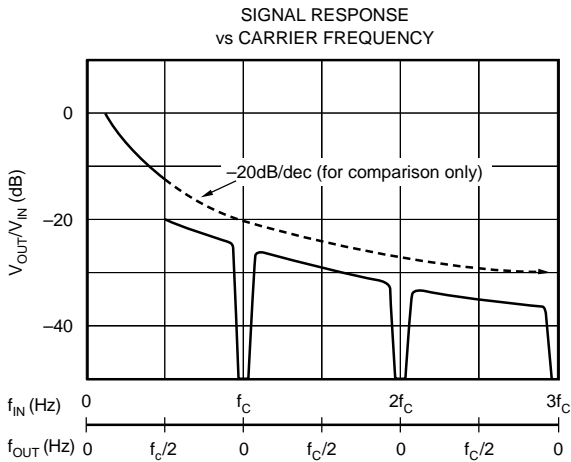
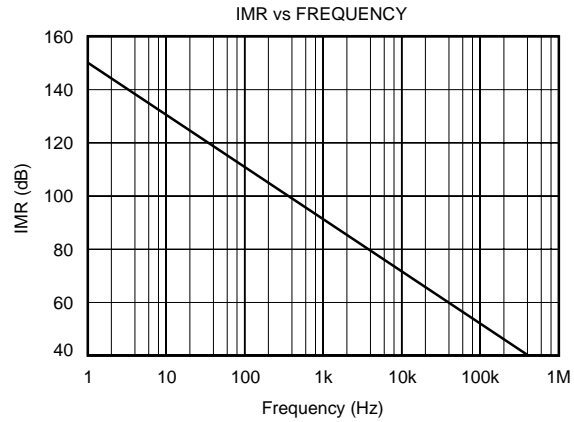
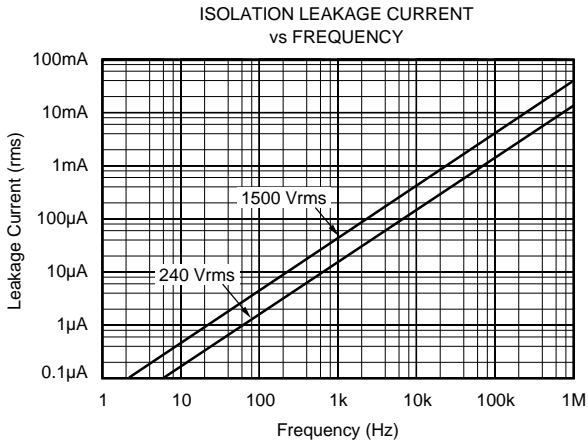
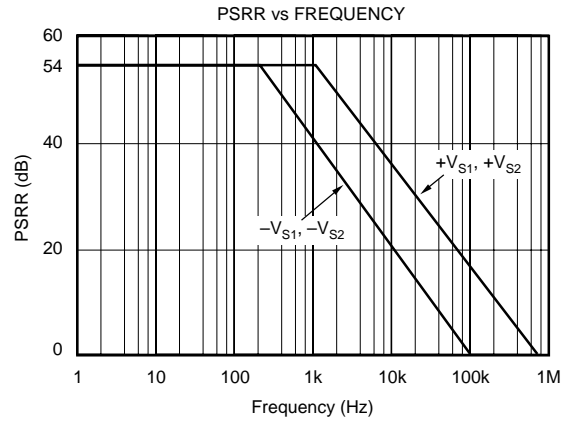
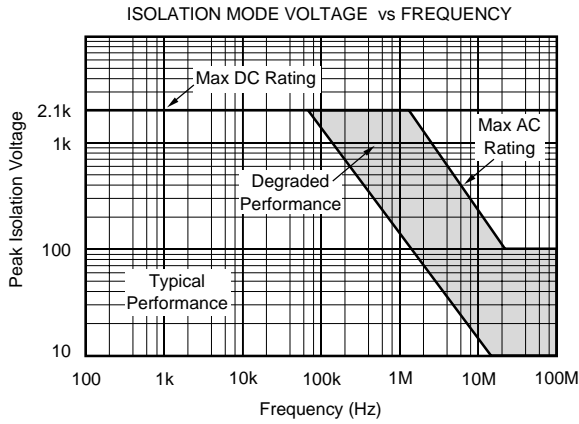

# 查询ISO176 供应商 TYPICAL PERFORMANCE CURVES (CONT)

At  $T_A = +25^\circ\text{C}$ ,  $V_{S1} = V_{S2} = \pm 15\text{V}$ , and  $R_L = 2\text{k}\Omega$ , unless otherwise noted.

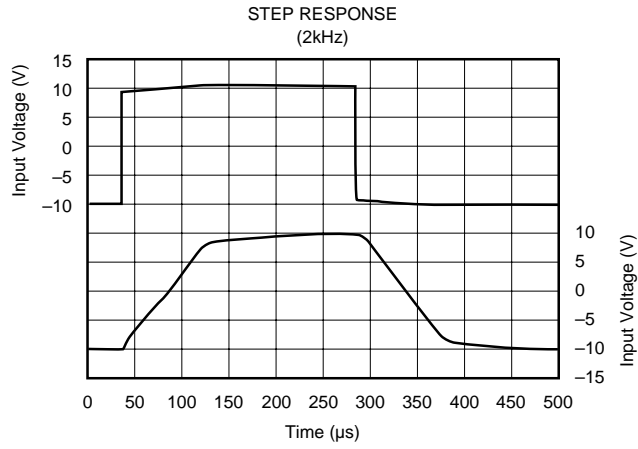
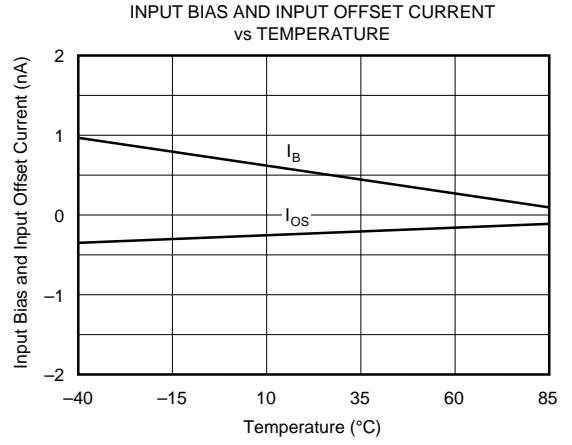
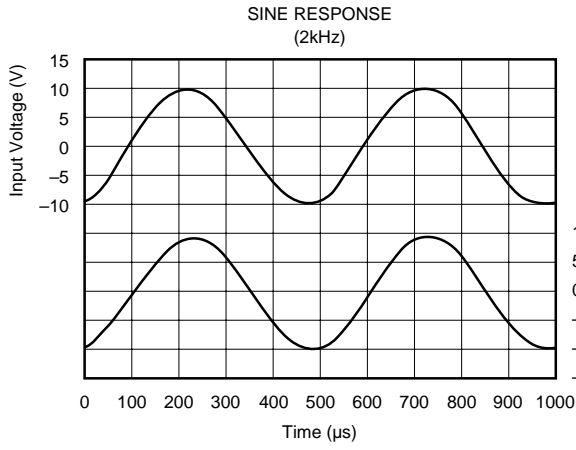

## BASIC OPERATION

查河ISO176快送商

ISO176 isolation amplifier comprises a precision uncommitted operational amplifier followed by an isolation amplifier. The input and output isolation sections are galvanically isolated by matched and EMI shielded capacitors.

### Signal and Power Connections

Figure 1 shows power and signal connections. Each power supply pin should be bypassed with a  $1\mu\text{F}$  tantalum capacitor located as close to the amplifier as possible. All ground connections should be run independently to a common point. Signal Common on both input and output sections provide a high-impedance point for sensing signal ground in noisy applications. Com 1 and Com 2 must have a path to ground for bias current return and should be maintained within  $\pm 1\text{V}$  of GND1 and GND2, respectively.

### INPUT PROTECTION

The amplifier inputs of ISO176 are protected with  $500\Omega$  series input resistors and diode clamps. The inputs can withstand  $\pm 30\text{V}$  differential inputs without damage. The protection diodes will, of course, conduct current when the inputs are over-driven. This may disturb the slewing behavior of unity-gain follower applications, but it will not damage the op amp. The MOD input is a  $200\text{k}\Omega$  resistor and can withstand  $\pm 100\text{V}$  without damage.

### INPUT BIAS CURRENT CANCELLATION

The input stage base current of the uncommitted op amp is internally compensated with an equal and opposite cancellation current. The resulting input bias current is the difference between the input stage base current and the cancellation current. This residual input bias current can be positive or negative.

When the bias current is cancelled in this manner, the input bias current and input offset current are approximately the same magnitude. As a result, it is not necessary to balance the DC resistance seen at the two input terminals. **A resistor added to balance the input resistances may actually increase offset and noise.**

### SYNCHRONIZED OPERATION

ISO176 can be synchronized to an external signal source. This capability is useful in eliminating troublesome beat frequencies in multichannel systems and in rejecting AC signals and their harmonics. To use this feature, an external signal must be applied to the Ext Osc pin. ISO176 can be synchronized over the  $400\text{kHz}$  to  $700\text{kHz}$  range.

The ideal external clock signal for ISO176 is a  $\pm 4\text{V}$  sine wave or  $\pm 4\text{V}$ , 50% duty-cycle triangle wave. The Ext Osc pin of the ISO176 can be driven directly with a  $\pm 3\text{V}$  to  $\pm 5\text{V}$  sine or 25% to 75% duty-cycle triangle wave and the ISO amp's internal modulator/demodulator circuitry will synchronize to the signal.

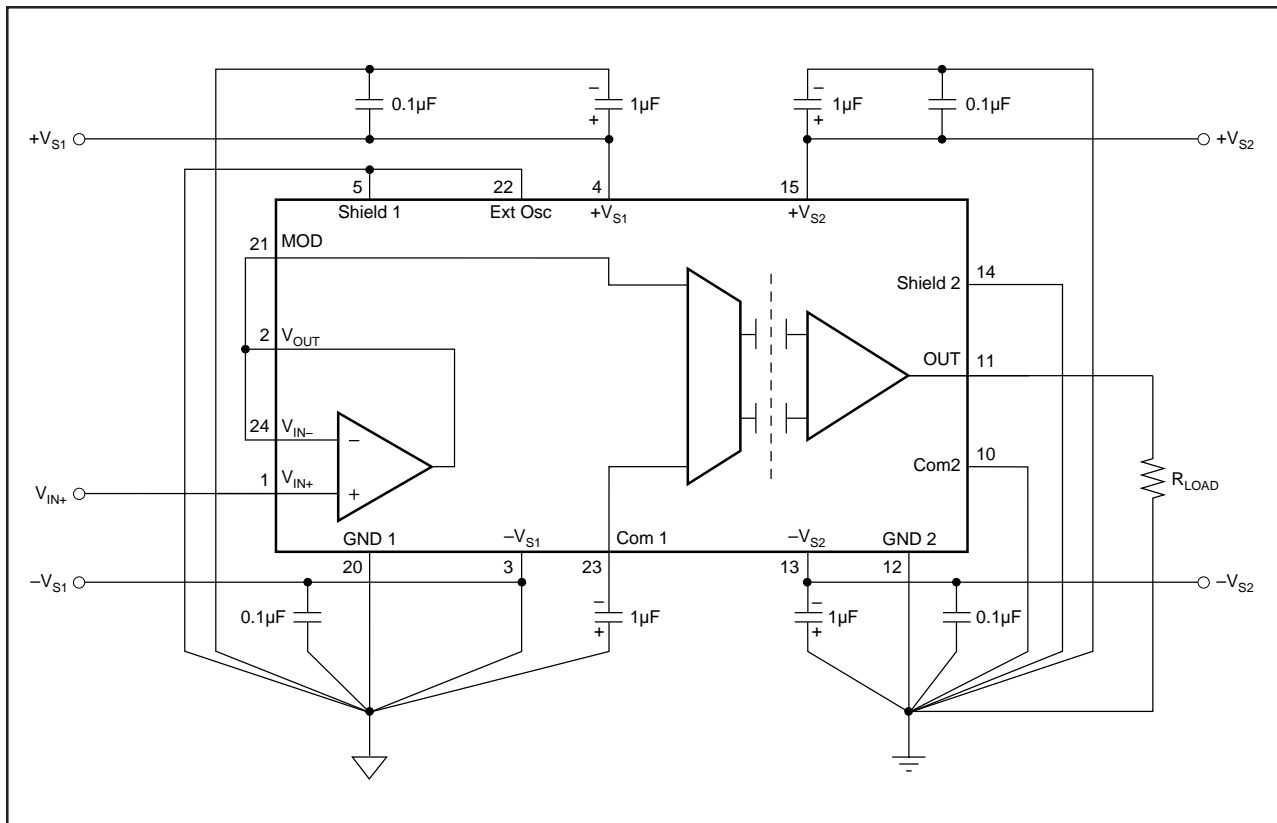

FIGURE 1. Basic Connections.

ISO176 can also be synchronized to a 400kHz to 700kHz Square-Wave External Clock since an internal clamp and filter provide signal conditioning. A square-wave signal of 25% to 75% duty cycle, and  $\pm 3V$  to  $\pm 20V$  level can be used to directly drive the ISO176.

With the addition of the signal conditioning circuit shown in Figure 2, any 10% to 90% duty-cycle square-wave signal can be used to drive the ISO176 Ext Osc pin. With the values shown, the circuit can be driven by a 4Vp-p TTL signal. For a higher or lower voltage input, increase or decrease the 1k $\Omega$  resistor,  $R_X$ , proportionally, e.g. for a  $\pm 4V$  square-wave (8Vp-p)  $R_X$  should be increased to 2k $\Omega$ . The value of  $C_X$  used in the Figure 2 circuit depends on the frequency of the external clock signal.  $C_X$  should be 30pF for ISO176.

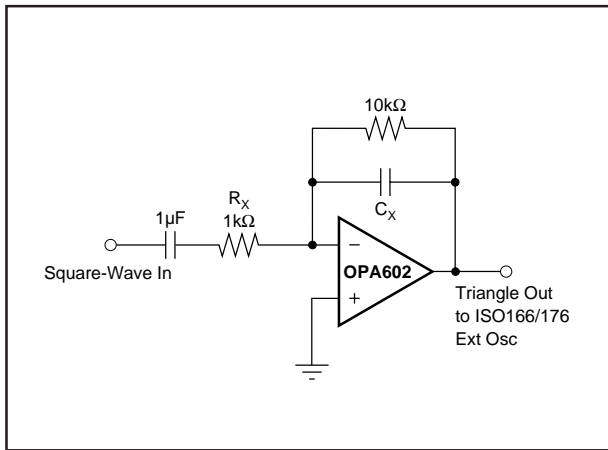

FIGURE 2. Square-Wave to Triangle Wave Signal Conditioner for Driving ISO176 Ext Osc Pin.

### CARRIER FREQUENCY CONSIDERATIONS

ISO176 amplifier transmits the signal across the ISO-barrier by a duty-cycle modulation technique. This system works like any linear amplifier for input signals having frequencies below one half the carrier frequency,  $f_C$ . For signal frequencies above  $f_C/2$ , the behavior becomes more complex. The Signal Response versus Carrier Frequency performance curve describes this behavior graphically. The upper curve illustrates the response for input signals varying from DC to  $f_C/2$ . At input frequencies at or above  $f_C/2$ , the device generates an output signal component that varies in both amplitude and frequency, as shown by the lower curve. The lower horizontal scale shows the periodic variation in the frequency of the output component. Note that at the carrier frequency and its harmonics, both the frequency and amplitude of the response go to zero. These characteristics can be exploited in certain applications.

It should be noted that for the ISO176, the carrier frequency is nominally 500kHz and the  $-3dB$  point of the amplifier is 60kHz. Spurious signals at the output are not significant under these circumstances unless the input signal contains significant components above 250kHz.

When periodic noise from external sources such as system clocks and DC/DC converters are a problem, ISO176 can be used to reject this noise. The amplifier can be synchronized to an external frequency source,  $f_{EXT}$ , placing the amplifier response curve at one of the frequency and amplitude nulls indicated in the “Signal Response vs Carrier Frequency” performance curve.

### ISOLATION MODE VOLTAGE

Isolation Mode Voltage (IMV) is the voltage appearing between isolated grounds GND1 and GND2. The IMV can induce error at the output as indicated by the plots of IMV versus Frequency. It should be noted that if the IMV frequency exceeds  $f_C/2$ , the output will display spurious outputs in a manner similar to that described above, and the amplifier response will be identical to that shown in the “Signal Response vs Carrier Frequency” performance curve. This occurs because IMV-induced errors behave like input-referred error signals. To predict the total IMR, divide the isolation voltage by the IMR shown in “IMR vs Frequency” performance curve and compute the amplifier response to this input-referred error signal from the data given in the “Signal Response vs Carrier Frequency” performance curve. Due to effects of very high-frequency signals, typical IMV performance can be achieved only when  $dV/dT$  of the isolation mode voltage falls below 1000V/ $\mu s$ . For convenience, this is plotted in the typical performance curves for the as a function of voltage and frequency for sinusoidal voltages. When  $dV/dT$  exceeds 1000V/ $\mu s$  but falls below 20kV/ $\mu s$ , performance may be degraded. At rates of change above 20kV/ $\mu s$ , the amplifier may be damaged, but the barrier retains its full integrity. Lowering the power supply voltages below  $\pm 15V$  may decrease the  $dV/dT$  to 500V/ $\mu s$  for typical performance, but the maximum  $dV/dT$  of 20kV/ $\mu s$  remains unchanged.

Leakage current is determined solely by the impedance of the barrier capacitance and is plotted in the “Isolation Leakage Current vs Frequency” curve.

### ISOLATION VOLTAGE RATINGS

Because a long-term test is impractical in a manufacturing situation, the generally accepted practice is to perform a production test at a higher voltage for some shorter time. The relationship between actual test voltage and the continuous derated maximum specification is an important one.

Historically, Burr-Brown has chosen a deliberately conservative one:  $V_{TEST} = (2 \times AC_{rms} \text{ continuous rating}) + 1000V$  for 10 seconds, followed by a test at rated ACrms voltage for one minute. This choice was appropriate for conditions where system transients are not well defined.

Recent improvements in high-voltage stress testing have produced a more meaningful test for determining maximum permissible voltage ratings, and Burr-Brown has chosen to apply this new technology in the manufacture and testing of the ISO176.

## PARTIAL DISCHARGE

[查询ISO176 供应商](#)

When an insulation defect such as a void occurs within an insulation system, the defect will display localized corona or ionization during exposure to high-voltage stress. This ionization requires a higher applied voltage to start the discharge and lower voltage to maintain it or extinguish it once started. The higher start voltage is known as the inception voltage, while the extinction voltage is that level of voltage stress at which the discharge ceases. Just as the total insulation system has an inception voltage, so do the individual voids. A voltage will build up across a void until its inception voltage is reached, at which point the void will ionize, effectively shorting itself out. This action redistributes electrical charge within the dielectric and is known as partial discharge. If, as is the case with AC, the applied voltage gradient across the device continues to rise, another partial discharge cycle begins. The importance of this phenomenon is that, if the discharge does not occur, the insulation system retains its integrity. If the discharge begins, and is allowed to continue, the action of the ions and electrons within the defect will eventually degrade any organic insulation system in which they occur. The measurement of partial discharge is still useful in rating the devices and providing quality control of the manufacturing process. The inception voltage for these voids tends to be constant, so that the measurement of total charge being redistributed within the dielectric is a very good indicator of the size of the voids and their likelihood of becoming an incipient failure. The bulk inception voltage, on the other hand, varies with the insulation system, and the number of ionization defects and directly establishes the absolute maximum voltage (transient) that can be applied across the test device before destructive partial discharge can begin. Measuring the bulk extinction voltage provides a lower, more conservative voltage from which to derive a safe continuous rating.

## PARTIAL DISCHARGE TESTING

Not only does this test method provide far more qualitative information about stress-withstand levels than did previous stress tests, but it provides quantitative measurements from which quality assurance and control measures can be based. Tests similar to this test have been used by some manufacturers, such as those of high-voltage power distribution equipment, for some time, but they employed a simple measurement of RF noise to detect ionization. This method was not quantitative with regard to energy of the discharge, and was not sensitive enough for small components such as isolation amplifiers. Now, however, manufacturers of HV test equipment have developed means to quantify partial discharge. VDE in Germany, an acknowledged leader in high-voltage test standards, has developed a standard test method to apply this powerful technique. Use of partial discharge testing is an improved method for measuring the integrity of an isolation barrier.

To accommodate poorly-defined transients, the part under test is exposed to voltage that is 1.6 times the continuous-rated voltage and must display less than or equal to 5pC partial discharge level in a 100% production test.

## APPLICATIONS

ISO176 isolation amplifiers are used in three categories of applications:

- Accurate isolation of signals from high voltage ground potentials.
- Accurate isolation of signals from severe ground noise and,
- Fault protection from high voltages in analog measurements.