

DESCRIPTION

The EV2365DN-01A is an evaluation board for the MP2365, a 1.4MHz step-down regulator with a built-in POWER MOSFET.

The MP2365 integrates a 120mΩ MOSFETS that provides 3A continuous load current over a wide operating input voltage of 4.75V to 28V.

Current mode control provides fast transient response and eases loop stabilization. An adjustable soft-start prevents inrush current at turn-on.

This device, available in an 8-pin SOIC and PDIP packages, provides a very compact system solution with minimal reliance on external components.

ELECTRICAL SPECIFICATIONS

Parameter	Symbol	Value	Units
Input Voltage	V _{IN}	4.75 – 28	V
Output Voltage	V _{OUT}	3.3	V
Output Current	I _{OUT}	3	A

FEATURES

- 3A Output Current
- Wide 4.75V to 28V Operating Input Range
- Adjustable Output from 0.92V to 21V
- Fully Assembled and Tested

APPLICATIONS

- Distributed Power Systems
- Battery Chargers
- Pre-Regulator for Linear Regulators

"MPS" and "The Future of Analog IC Technology" are Trademarks of Monolithic Power Systems, Inc.

EV2365DN-01A EVALUATION BOARD



(L x W x H) 2.0" x 1.9" x 0.5"
(5.0cm x 4.8 x 1.2cm)

Board Number	MPS IC Number
EV2365DN-01A	MP2365DN

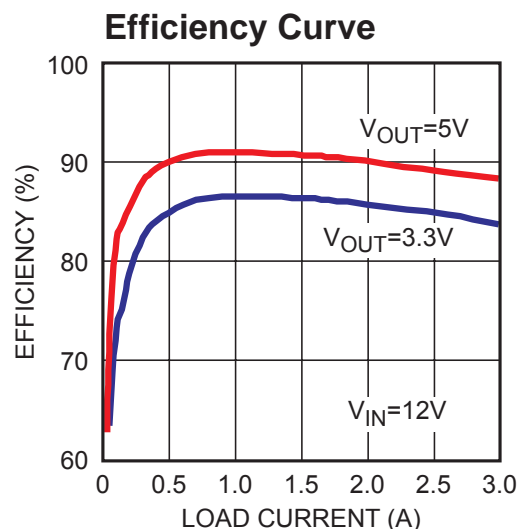

[查询"MP2365DN"供应商](#)

EVALUATION BOARD SCHEMATIC

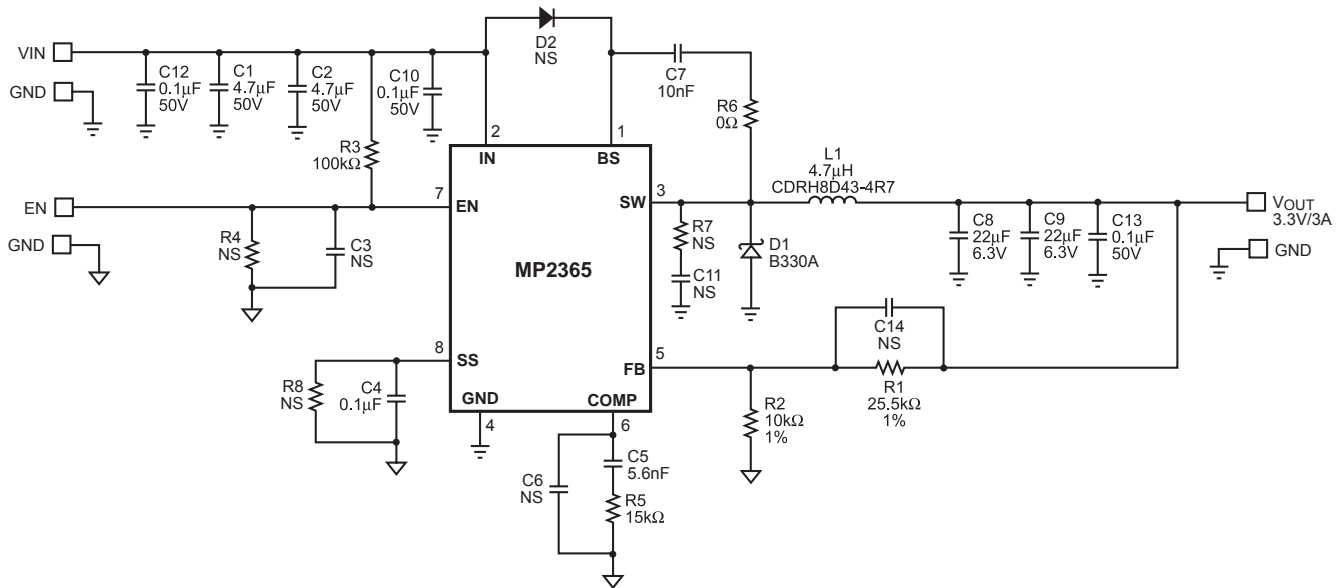

EV2365DN-01A BILL OF MATERIALS

Qty	Ref	Value	Description	Package	Manufacturer	Part Number
2	C1, C2	4.7 μ F	Ceramic Cap., 50V, X7R	1210	Murata	GRM32ER71H475KA88L
4	C3, C6, C11, C14		Not Stuffed			
1	C4	0.1 μ F	Ceramic Cap., 25V, X7R	603	TDK	C1608X7R1E104K
1	C5	5.6nF	Ceramic Cap., 50V, X7R	603	Panasonic	ECJ-1VB1H562K
1	C7	10nF	Ceramic Cap., 50V, X7R	603	TDK	C1608X7R1H103K
2	C8, C9	22 μ F	Ceramic Cap., 6.3V, X5R	1210	TDK	C3225X5R0J226M
3	C10, C12, C13	0.1 μ F	Ceramic Cap., 50V, X7R	805	TDK	C2012X7R1H104K
1	R1	25.5k Ω	Film Res., 1%	603	Panasonic	ERJ-3EKF2552V
1	R2	10k Ω	Film Res., 1%	603	Panasonic	ERJ-3EKF1002V
1	R3	100k Ω	Film Res., 5%	603	Panasonic	ERJ-3GEYJ104V
3	R4, R7, R8		Not Stuffed			
1	R5	15k Ω	Film Res., 5%	603	Panasonic	ERJ-3GEYJ153V
1	R6	0 Ω	Film Res., 5%	603	Panasonic	ERJ-3GEYJ0R00V
1	D1		Diode Schottky, 30V, 3A	SMA	Diodes Inc	B330A-13
1	D2		Not Stuffed			
1	L1		Inductor, 4.1A	SMD	Sumida	CDRH8D43-4R7NC
1	U1		DC-DC Converter	SO-8	MPS	MP2365DN

PRINTED CIRCUIT BOARD LAYOUT

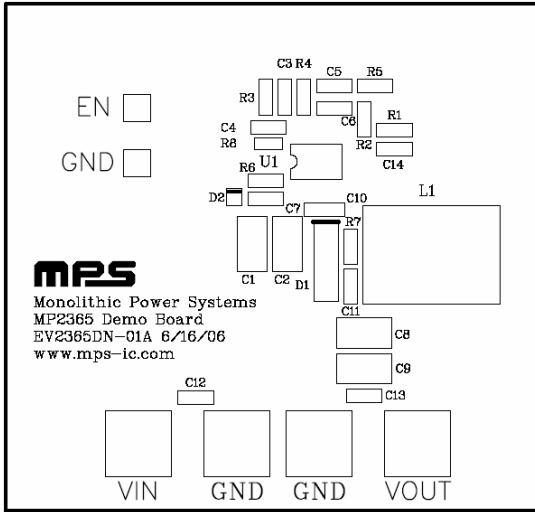

Figure 1—Top Silk Layer

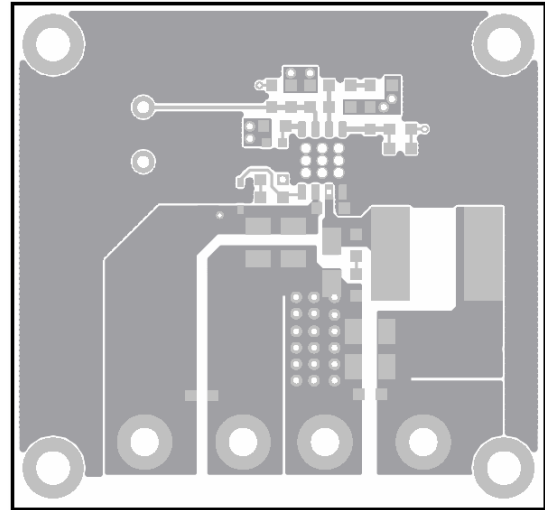

Figure 2—Top Layer

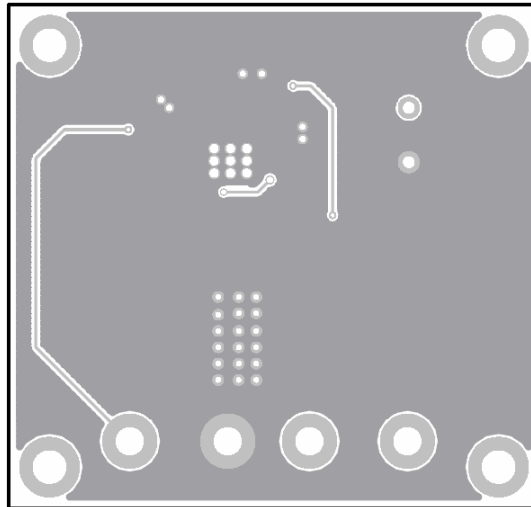

Figure 3—Bottom Layer

[查询"MP2365DN"供应商](#)

QUICK START GUIDE

1. Connect the positive and negative terminals of the load to the VOUT and GND pins, respectively.
2. Preset the power supply output to between 4.75V and 28V, then turn it off.
3. Connect the positive and negative terminals of the power supply output to the VIN and GND pins, respectively.
4. Turn the power supply on (the MP2365 will automatically startup).
5. To use the Enable function, apply a digital input to the EN pin. Drive EN higher than 2.9V to turn on the regulator or less than 0.9V to turn it off.
6. An under voltage lockout (UVLO) function can be implemented by the addition of a resistor divider (R3 and R4). The Enable threshold is 2.6V, so the VIN UVLO threshold is:

$$\left(1 + \frac{R3}{R4}\right) \times 2.6V.$$

NOTICE: The information in this document is subject to change without notice. Users should warrant and guarantee that third party Intellectual Property rights are not infringed upon when integrating MPS products into any application. MPS will not assume any legal responsibility for any said applications.