

# 256M bits DDR SDRAM

## EDD2516AMTA-6B-E (16M words × 16 bits)

### Description

The EDD2516AMTA is 256M bits Double Data Rate (DDR) SDRAM organized as 4,194,304 words × 16 bits × 4 banks. Read and write operations are performed at the cross points of the CK and the /CK. This high-speed data transfer is realized by the 2 bits prefetch-pipelined architecture. Data strobe (DQS) both for read and write are available for high speed and reliable data bus design. By setting extended mode register, the on-chip Delay Locked Loop (DLL) can be set enable or disable. They are packaged in standard 66-pin plastic TSOP (II).

### Features

- 2.5 V power supply: VDD, VDDQ = 2.5V ± 0.2V
- Data rate: 333Mbps (max.)
- Double Data Rate architecture; two data transfers per clock cycle
- Bi-directional data strobe (DQS) is transmitted /received with data for capturing data at the receiver
- Data inputs, outputs, and DM are synchronized with DQS
- 4 internal banks for concurrent operation
- DQS is edge aligned with data for READs; center aligned with data for WRITEs
- Differential clock inputs (CK and /CK)
- DLL aligns DQ and DQS transitions with CK transitions
- Commands entered on each positive CK edge; data and data mask referenced to both edges of DQS
- Data mask (DM) for write data
- Auto precharge option for each burst access
- SSTL\_2 compatible I/O
- Programmable burst length (BL): 2, 4, 8
- Programmable /CAS latency (CL): 2, 2.5
- Programmable output driver strength: normal/weak
- Refresh cycles: 8192 refresh cycles/64ms
  - 7.8µs maximum average periodic refresh interval
- 2 variations of refresh
  - Auto refresh
  - Self refresh
- TSOP (II) package with lead free solder (Sn-Bi)
  - RoHS compliant

### Pin Configurations

/xxx indicates active low signal.

66-pin Plastic TSOP(II)

|         |    |    |      |
|---------|----|----|------|
| VDD     | 1  | 66 | VSS  |
| DQ0     | 2  | 65 | DQ15 |
| VDDQ    | 3  | 64 | VSSQ |
| DQ1     | 4  | 63 | DQ14 |
| DQ2     | 5  | 62 | DQ13 |
| VSSQ    | 6  | 61 | VDDQ |
| DQ3     | 7  | 60 | DQ12 |
| DQ4     | 8  | 59 | DQ11 |
| VDDQ    | 9  | 58 | VSSQ |
| DQ5     | 10 | 57 | DQ10 |
| DQ6     | 11 | 56 | DQ9  |
| VSSQ    | 12 | 55 | VDDQ |
| DQ7     | 13 | 54 | DQ8  |
| NC      | 14 | 53 | NC   |
| VDDQ    | 15 | 52 | VSSQ |
| LDQS    | 16 | 51 | UDQS |
| NC      | 17 | 50 | NC   |
| VDD     | 18 | 49 | VREF |
| NC      | 19 | 48 | VSS  |
| LDM     | 20 | 47 | UDM  |
| /WE     | 21 | 46 | /CK  |
| /CAS    | 22 | 45 | CK   |
| /RAS    | 23 | 44 | CKE  |
| /CS     | 24 | 43 | NC   |
| NC      | 25 | 42 | A12  |
| BA0     | 26 | 41 | A11  |
| BA1     | 27 | 40 | A9   |
| A10(AP) | 28 | 39 | A8   |
| A0      | 29 | 38 | A7   |
| A1      | 30 | 37 | A6   |
| A2      | 31 | 36 | A5   |
| A3      | 32 | 35 | A4   |
| VDD     | 33 | 34 | VSS  |

(Top view)

|             |                               |
|-------------|-------------------------------|
| A0 to A12   | Address input                 |
| BA0, BA1    | Bank select address           |
| DQ0 to DQ15 | Data-input/output             |
| UDQS/LDQS   | Input and output data strobe  |
| /CS         | Chip select                   |
| /RAS        | Row address strobe command    |
| /CAS        | Column address strobe command |
| /WE         | Write enable                  |
| UDM/LDM     | Input mask                    |
| CK          | Clock input                   |
| /CK         | Differential clock input      |
| CKE         | Clock enable                  |
| VREF        | Input reference voltage       |
| VDD         | Power for internal circuit    |
| VSS         | Ground for internal circuit   |
| VDDQ        | Power for DQ circuit          |
| VSSQ        | Ground for DQ circuit         |
| NC          | No connection                 |



[查询"EDD2516AMTA-6B-E"供应商](#)  
Ordering information

| Part number      | Mask version | Organization (words × bits) | Internal banks | Data rate Mbps (max.) | Speed bin (CL-tRCD-tRP) | Package                  |
|------------------|--------------|-----------------------------|----------------|-----------------------|-------------------------|--------------------------|
| EDD2516AMTA-6B-E | M            | 16M × 16                    |                | 333                   | DDR-333B (2.5-3-3)      | 66-pin Plastic TSOP (II) |

Part Number

**E D D 25 16 A M T A - 6 B - E**

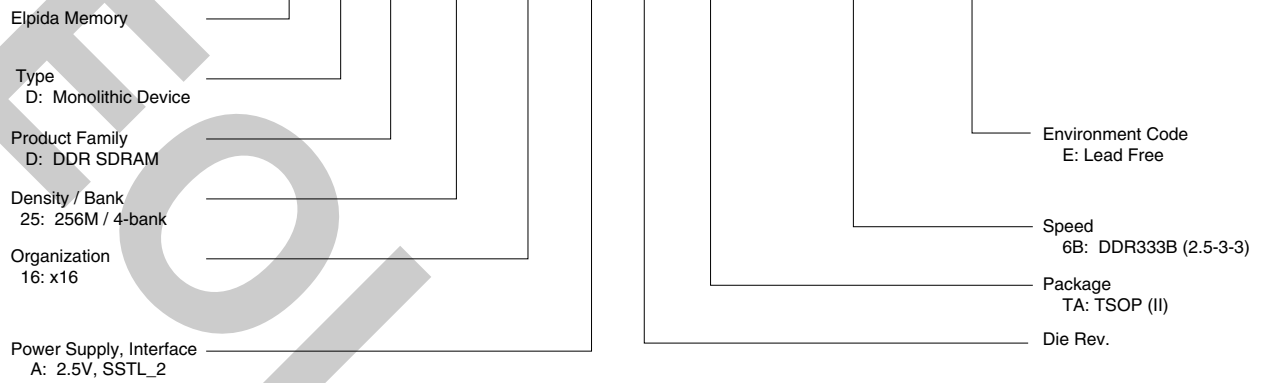

[查询"EDD2516AMTA-6B-E"供应商](#)

**CONTENTS**

|  |    |
|--|----|
| Description .....                      | 1  |
| Features .....                         | 1  |
| Pin Configurations .....               | 1  |
| Ordering Information .....             | 2  |
| Part Number .....                      | 2  |
| Electrical Specifications .....        | 4  |
| Block Diagram .....                    | 11 |
| Pin Function .....                     | 12 |
| Command Operation .....                | 14 |
| Simplified State Diagram .....         | 21 |
| Operation of the DDR SDRAM .....       | 22 |
| Timing Waveforms .....                 | 24 |
| Package Drawing .....                  | 30 |
| Recommended Soldering Conditions ..... | 31 |

查询"EDD2516AMTA-6B-E"供应商  
 Electrical Specifications

- All voltages are referenced to VSS (GND).
- After power up, wait more than 200  $\mu$ s and then, execute power on sequence and CBR (Auto) refresh before proper device operation is achieved.

**Absolute Maximum Ratings**

| Parameter                                 | Symbol | Rating            | Unit         | Note |
|---|--------|-------------------|--------------|------|
| Voltage on input pin relative to VSS      | VI     | -0.5 to VDD +0.5  | V            |      |
| Voltage on DQ and DQS pin relative to VSS | VIO    | -0.5 to VDDQ +0.5 | V            |      |
| Supply voltage relative to VSS            | VDD    | -0.5 to +3.7      | V            |      |
| Supply voltage for output relative to VSS | VDDQ   | -0.5 to +3.7      | V            |      |
| Short circuit output current              | IOS    | 50                | mA           |      |
| Power dissipation                         | PD     | 1.0               | W            |      |
| Operating temperature                     | TA     | 0 to +70          | $^{\circ}$ C |      |
| Storage temperature                       | Tstg   | -55 to +125       | $^{\circ}$ C |      |

**Caution**

Exposing the device to stress above those listed in Absolute Maximum Ratings could cause permanent damage. The device is not meant to be operated under conditions outside the limits described in the operational section of this specification. Exposure to Absolute Maximum Rating conditions for extended periods may affect device reliability.

**Recommended DC Operating Conditions (TA = 0 $^{\circ}$ C to 70 $^{\circ}$ C)**

| Parameter   | Symbol    | min.                     | typ.               | max.                     | Unit | Notes |
|---|-----------|--------------------------|--------------------|--------------------------|------|-------|
| Supply voltage  | VDD, VDDQ | 2.3                      | 2.5                | 2.7                      | V    | 1     |
|   | VSS, VSSQ | 0                        | 0                  | 0                        | V    |       |
| Input reference voltage                                   | VREF      | $0.49 \times VDDQ$       | $0.50 \times VDDQ$ | $0.51 \times VDDQ$       | V    |       |
| Termination voltage                                       | VTT       | $VREF - 0.04$            | VREF               | $VREF + 0.04$            | V    |       |
| Input high voltage  | VIH (DC)  | $VREF + 0.15$            | —                  | $VDDQ + 0.3$             | V    |       |
| Input low voltage   | VIL (DC)  | -0.3                     | —                  | $VREF - 0.15$            | V    |       |
| Input voltage level, CK and /CK inputs                    | VIN (DC)  | -0.3                     | —                  | $VDDQ + 0.3$             | V    | 2     |
| Input differential cross point voltage, CK and /CK inputs | VIX (DC)  | $0.5 \times VDDQ - 0.2V$ | $0.5 \times VDDQ$  | $0.5 \times VDDQ + 0.2V$ | V    |       |
| Input differential voltage, CK and /CK inputs             | VID (DC)  | 0.36                     | —                  | $VDDQ + 0.6$             | V    | 3, 4  |

- Notes: 1. VDDQ must be lower than or equal to VDD.  
 2. VIN (DC) specifies the allowable DC execution of each differential input.  
 3. VID (DC) specifies the input differential voltage required for switching.  
 4. VIH (CK) min assumed over  $VREF + 0.18V$ , VIL (CK) max assumed under  $VREF - 0.18V$  if measurement.

[查询"EDD2516AMTA-6B-E"供应商](#)  
 AC Overshoot/Undershoot Specification

| Parameter  | Specification |
|--|---------------|
| Maximum peak amplitude allowed for overshoot                                 | 1.6V          |
| Maximum peak amplitude allowed for undershoot                                | 1.6V          |
| The area between the overshoot signal and VDD must be less than or equal to  | 4.5V-ns       |
| The area between the undershoot signal and GND must be less than or equal to | 4.5V-ns       |

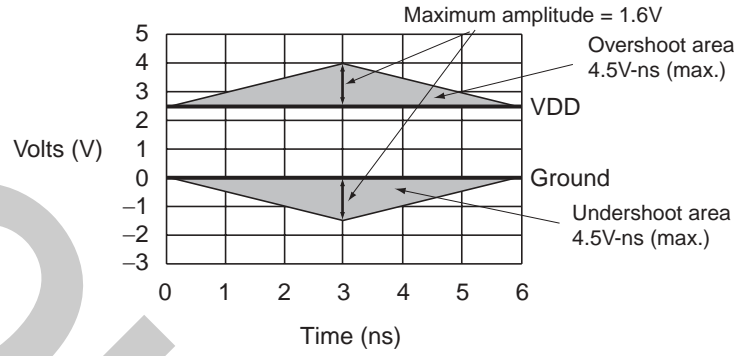

查询"EDD2516AMTA-6B-E"供应商

DC Characteristics 1 (TA = 0°C to +70°C, VDD, VDDQ = 2.5V ± 0.2V, VSS, VSSQ = 0V)

| Parameter                                 | Symbol | Grade | max. | Unit | Test condition                                      | Notes      |
|---|--------|-------|------|------|---|------------|
| Operating current (ACT-PRE)               | IDD0   |       | 85   | mA   | CKE ≥ VIH,<br>tRC = tRC (min.)                      | 1, 2, 9    |
| Operating current (ACT-READ-PRE)          | IDD1   |       | 125  | mA   | CKE ≥ VIH, BL = 4,<br>CL = 2.5,<br>tRC = tRC (min.) | 1, 2, 5    |
| Idle power down standby current           | IDD2P  |       | 4    | mA   | CKE ≤ VIL   | 4          |
| Floating idle standby current             | IDD2F  |       | 35   | mA   | CKE ≥ VIH, /CS ≥ VIH<br>DQ, DQS, DM = VREF          | 4, 5       |
| Quiet idle standby current                | IDD2Q  |       | 35   | mA   | CKE ≥ VIH, /CS ≥ VIH<br>DQ, DQS, DM = VREF          | 4, 10      |
| Active power down standby current         | IDD3P  |       | 25   | mA   | CKE ≤ VIL   | 3          |
| Active standby current                    | IDD3N  |       | 45   | mA   | CKE ≥ VIH, /CS ≥ VIH<br>tRAS = tRAS (max.)          | 3, 5, 6    |
| Operating current (Burst read operation)  | IDD4R  |       | 250  | mA   | CKE ≥ VIH, BL = 2,<br>CL = 2.5                      | 1, 2, 5, 6 |
| Operating current (Burst write operation) | IDD4W  |       | 200  | mA   | CKE ≥ VIH, BL = 2,<br>CL = 2.5                      | 1, 2, 5, 6 |
| Auto Refresh current                      | IDD5   |       | 145  | mA   | tRFC = tRFC (min.),<br>Input ≤ VIL or ≥ VIH         |            |
| Self refresh current                      | IDD6   |       | 3    | mA   | Input ≥ VDD - 0.2 V<br>Input ≤ 0.2 V                |            |
| Operating current (4 banks interleaving)  | IDD7A  |       | 330  | mA   | BL = 4  | 1, 5, 6, 7 |

- Notes: 1. These IDD data are measured under condition that DQ pins are not connected.  
 2. One bank operation.  
 3. One bank active.  
 4. All banks idle.  
 5. Command/Address transition once per one clock cycle.  
 6. DQ, DM and DQS transition twice per one clock cycle.  
 7. 4 banks active. Only one bank is running at tRC = tRC (min.)  
 8. The IDD data on this table are measured with regard to tCK = tCK (min.) in general.  
 9. Command/Address transition once every two clock cycle.  
 10. Command/Address stable at ≥ VIH or ≤ VIL.

DC Characteristics 2 (TA = 0°C to +70°C, VDD, VDDQ = 2.5V ± 0.2V, VSS, VSSQ = 0V)

| Parameter              | Symbol | min.  | max. | Unit | Test condition    | Notes |
|------------------------|--------|-------|------|------|-------------------|-------|
| Input leakage current  | ILI    | -2    | 2    | μA   | VDD ≥ VIN ≥ VSS   |       |
| Output leakage current | ILO    | -5    | 5    | μA   | VDDQ ≥ VOUT ≥ VSS |       |
| Output high current    | IOH    | -16.2 | —    | mA   | VOUT = 1.95V      |       |
| Output low current     | IOL    | 16.2  | —    | mA   | VOUT = 0.35V      |       |

查询"EDD2516AMTA-6B-E"供应商  
Pin Capacitance (TA = +25°C, VDD, VDDQ = 2.5V ± 0.2V)

| Parameter                      | Symbol | Pins                      | min. | typ. | max. | Unit | Notes |
|--------------------------------|--------|---------------------------|------|------|------|------|-------|
| Input capacitance              | CI1    | CK, /CK                   | 2.0  | —    | 3.0  | pF   | 1     |
|                                | CI2    | All other input pins      | 2.0  | —    | 3.0  | pF   | 1     |
| Delta input capacitance        | Cdi1   | CK, /CK                   | —    | —    | 0.25 | pF   | 1     |
|                                | Cdi2   | All other input-only pins | —    | —    | 0.5  | pF   | 1     |
| Data input/output capacitance  | CI/O   | DQ, DM, DQS               | 4.0  | —    | 5    | pF   | 1, 2, |
| Delta input/output capacitance | Cdio   | DQ, DM, DQS               | —    | —    | 0.5  | pF   | 1     |

Notes: 1. These parameters are measured on conditions: f = 100MHz, VOUT = VDDQ/2, ΔVOUT = 0.2V, TA = +25°C.

2. DOUT circuits are disabled.

AC Characteristics (TA = 0°C to +70°C, VDD, VDDQ = 2.5V ± 0.2V, VSS, VSSQ = 0V)

| Parameter                                      | Symbol | -6B            |      | Unit | Notes |
|--|--------|----------------|------|------|-------|
|  |        | min.           | max. |      |       |
| Clock cycle time<br>(CL = 2)                   | tCK    | 7.5            | 12   | ns   | 10    |
|  | tCK    | 6              | 12   | ns   |       |
| (CL = 2.5)                                     | tCK    | 6              | 12   | ns   |       |
| CK high-level width                            | tCH    | 0.45           | 0.55 | tCK  |       |
| CK low-level width                             | tCL    | 0.45           | 0.55 | tCK  |       |
| CK half period                                 | tHP    | min (tCH, tCL) | —    | tCK  |       |
| DQ output access time from CK, /CK             | tAC    | -0.7           | 0.7  | ns   | 2, 11 |
| DQS output access time from CK, /CK            | tDQSCK | -0.6           | 0.6  | ns   | 2, 11 |
| DQS to DQ skew                                 | tDQSQ  | —              | 0.45 | ns   | 3     |
| DQ/DQS output hold time from DQS               | tQH    | tHP - tQHS     | —    | ns   |       |
| Data hold skew factor                          | tQHS   | —              | 1    | ns   |       |
| Data-out high-impedance time from CK, /CK      | tHZ    | -0.7           | 0.7  | ns   | 5, 11 |
| Data-out low-impedance time from CK, /CK       | tLZ    | -0.7           | 0.7  | ns   | 6, 11 |
| Read preamble                                  | tRPRE  | 0.9            | 1.1  | tCK  |       |
| Read postamble                                 | tRPST  | 0.3            | 0.7  | tCK  |       |
| DQ and DM input setup time                     | tDS    | 0.50           | —    | ns   | 8     |
| DQ and DM input hold time                      | tDH    | 0.50           | —    | ns   | 8     |
| DQ and DM input pulse width                    | tDIPW  | 1.75           | —    | ns   | 7     |
| Write preamble setup time                      | tWPRES | 0              | —    | ns   |       |
| Write preamble                                 | tWPRE  | 0.25           | —    | tCK  |       |
| Write postamble                                | tWPST  | 0.4            | 0.6  | tCK  | 9     |
| Write command to first DQS latching transition | tDQSS  | 0.75           | 1.25 | tCK  |       |
| DQS falling edge to CK setup time              | tDSS   | 0.2            | —    | tCK  |       |
| DQS falling edge hold time from CK             | tDSH   | 0.2            | —    | tCK  |       |
| DQS input high pulse width                     | tDQSH  | 0.35           | —    | tCK  |       |
| DQS input low pulse width                      | tDQSL  | 0.35           | —    | tCK  |       |
| Address and control input setup time           | tIS    | 0.75           | —    | ns   | 8     |
| Address and control input hold time            | tIH    | 0.75           | —    | ns   | 8     |
| Address and control input pulse width          | tIPW   | 2.2            | —    | ns   | 7     |

查询"EDD2516AMTA-6B-E"供应商

| Parameter  | Symbol | -6B                   |        | Unit | Notes |
|--|--------|-----------------------|--------|------|-------|
|  |        | min.                  | max.   |      |       |
| Mode register set command cycle time               | tMRD   | 2                     | —      | tCK  |       |
| Active to Precharge command period                 | tRAS   | 42                    | 120000 | ns   |       |
| Active to Active/Auto refresh command period       | tRC    | 60                    | —      | ns   |       |
| Auto refresh to Active/Auto refresh command period | tRFC   | 72                    | —      | ns   |       |
| Active to Read/Write delay                         | tRCD   | 18                    | —      | ns   |       |
| Precharge to active command period                 | tRP    | 18                    | —      | ns   |       |
| Active to Autoprecharge delay                      | tRAP   | tRCD min.             | —      | ns   |       |
| Active to active command period                    | tRRD   | 12                    | —      | ns   |       |
| Write recovery time                                | tWR    | 15                    | —      | ns   |       |
| Auto precharge write recovery and precharge time   | tDAL   | (tWR/tCK) + (tRP/tCK) | —      | tCK  | 13    |
| Internal write to Read command delay               | tWTR   | 1                     | —      | tCK  |       |
| Average periodic refresh interval                  | tREF   | —                     | 7.8    | μs   |       |

Notes: 1. On all AC measurements, we assume the test conditions shown in the next page. For timing parameter definitions, see 'Timing Waveforms' section.

2. This parameter defines the signal transition delay from the cross point of CK and /CK. The signal transition is defined to occur when the signal level crossing VTT.
3. The timing reference level is VTT.
4. Output valid window is defined to be the period between two successive transition of data out or DQS (read) signals. The signal transition is defined to occur when the signal level crossing VTT.
5. tHZ is defined as DOUT transition delay from Low-Z to High-Z at the end of read burst operation. The timing reference is cross point of CK and /CK. This parameter is not referred to a specific DOUT voltage level, but specify when the device output stops driving.
6. tLZ is defined as DOUT transition delay from High-Z to Low-Z at the beginning of read operation. This parameter is not referred to a specific DOUT voltage level, but specify when the device output begins driving.
7. Input valid windows is defined to be the period between two successive transition of data input or DQS (write) signals. The signal transition is defined to occur when the signal level crossing VREF.
8. The timing reference level is VREF.
9. The transition from Low-Z to High-Z is defined to occur when the device output stops driving. A specific reference voltage to judge this transition is not given.
10. tCK (max.) is determined by the lock range of the DLL. Beyond this lock range, the DLL operation is not assured.
11. tCK = tCK (min) when these parameters are measured. Otherwise, absolute minimum values of these values are 10% of tCK.
12. VDD is assumed to be 2.5V ± 0.2V. VDD power supply variation per cycle expected to be less than 0.4V/400 cycle.
13. tDAL = (tWR/tCK)+(tRP/tCK)

For each of the terms above, if not already an integer, round to the next highest integer.

Example: For -6B Speed at CL = 2.5, tCK = 6ns, tWR = 15ns and tRP= 18ns,

$$tDAL = (15ns/6ns) + (18ns/6ns) = (3) + (3)$$

$$tDAL = 6 \text{ clocks}$$



查询"EDD2516AMTA-6B-E"供应商  
Test Conditions

| Parameter   | Symbol   | Value       | Unit |
|---|----------|-------------|------|
| Input reference voltage                                   | VREF     | VDDQ/2      | V    |
| Termination voltage                                       | VTT      | VREF        | V    |
| Input high voltage  | VIH (AC) | VREF + 0.80 | V    |
| Input low voltage   | VIL (AC) | VREF - 0.80 | V    |
| Input differential voltage, CK and /CK inputs             | VID (AC) | 1.6         | V    |
| Input differential cross point voltage, CK and /CK inputs | VIX (AC) | VREF        | V    |
| Input signal slew rate                                    | SLEW     | 1           | V/ns |

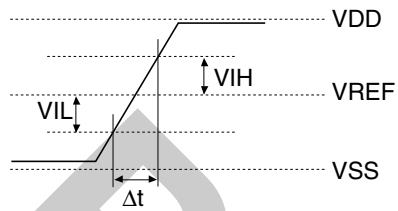
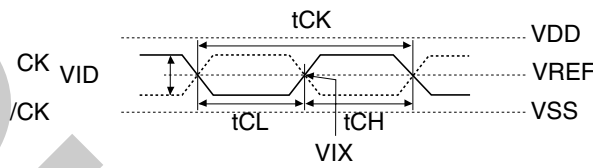

$$SLEW = (VIH (AC) - VIL (AC)) / \Delta t$$

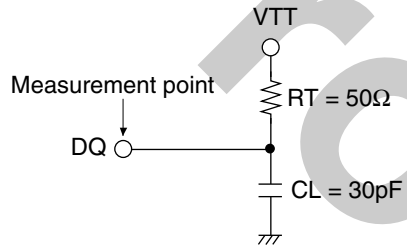

Input Waveforms and Output Load

查询"EDD2516AMTA-6B-E"供应商  
Timing Parameter Measured in Clock Cycle

| tCK | Parameter   | Symbol | Number of clock cycle |      | Unit |
|-----|---|--------|-----------------------|------|------|
|     |   |        | min.                  | max. |      |
|     | Write to pre-charge command delay (same bank)                     | tWPD   | 4 + BL/2              | —    | tCK  |
|     | Read to pre-charge command delay (same bank)                      | tRPD   | BL/2                  | —    | tCK  |
|     | Write to read command delay (to input all data)                   | tWRD   | 2 + BL/2              | —    | tCK  |
|     | Burst stop command to write command delay (CL = 2)                | tBSTW  | 2                     | —    | tCK  |
|     | (CL = 2.5)  | tBSTW  | 3                     | —    | tCK  |
|     | Burst stop command to DQ High-Z (CL = 2)                          | tBSTZ  | 2                     | 2    | tCK  |
|     | (CL = 2.5)  | tBSTZ  | 2.5                   | 2.5  | tCK  |
|     | Read command to write command delay (to output all data) (CL = 2) | tRWD   | 2 + BL/2              | —    | tCK  |
|     | (CL = 2.5)  | tRWD   | 3 + BL/2              | —    | tCK  |
|     | Pre-charge command to High-Z (CL = 2)                             | tHWP   | 2                     | 2    | tCK  |
|     | (CL = 2.5)  | tHWP   | 2.5                   | 2.5  | tCK  |
|     | Write command to data in latency                                  | tWCD   | 1                     | 1    | tCK  |
|     | Write recovery  | tWR    | 3                     | —    | tCK  |
|     | DM to data in latency   | tDMD   | 0                     | 0    | tCK  |
|     | Mode register set command cycle time                              | tMRD   | 2                     | —    | tCK  |
|     | Self refresh exit to non-read command                             | tSNR   | 12                    | —    | tCK  |
|     | Self refresh exit to read command                                 | tSRD   | 200                   | —    | tCK  |
|     | Power down entry  | tPDEN  | 1                     | 1    | tCK  |
|     | Power down exit to command input                                  | tPDEX  | 1                     | —    | tCK  |

查询"EDD2516AMTA-6B-E"供应商  
Block Diagram

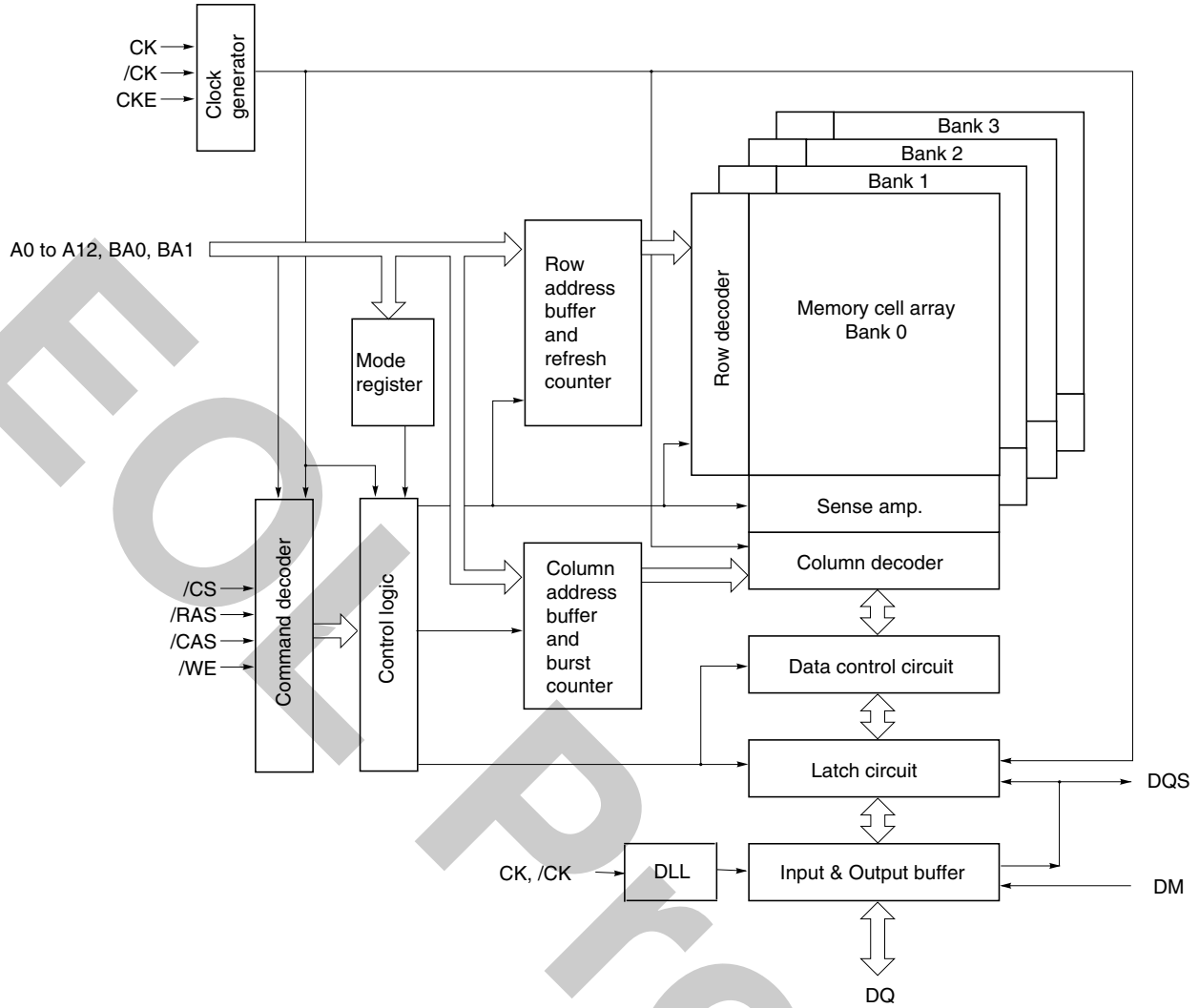

[查询"EDD2516AMTA-6B-E"供应商](#)

**Pin Function**

**CK, /CK (input pins)**

The CK and the /CK are the master clock inputs. All inputs except DM, DQS and DQs are referred to the cross point of the CK rising edge and the /CK falling edge. When a read operation, DQS and DQs are referred to the cross point of the CK and the /CK. When a write operation, DQS and DQs are referred to the cross point of the DQS and the VREF level. DQS for write operation is referred to the cross point of the CK and the /CK. CK is the master clock input to this pin. The other input signals are referred at CK rising edge.

**/CS (input pin)**

When /CS is Low, commands and data can be input. When /CS is High, all inputs are ignored. However, internal operations (bank active, burst operations, etc.) are held.

**/RAS, /CAS, and /WE (input pins)**

These pins define operating commands (read, write, etc.) depending on the combinations of their voltage levels. See "Command operation".

**A0 to A12 (input pins)**

Row address (AX0 to AX12) is determined by the A0 to the A12 level at the cross point of the CK rising edge and the /CK falling edge in a bank active command cycle. Column address (See "Address Pins Table") is loaded via the A0 to the A8 at the cross point of the CK rising edge and the /CK falling edge in a read or a write command cycle. This column address becomes the starting address of a burst operation.

**[Address Pins Table]**

| Part number | Address (A0 to A12) |                |
|-------------|---------------------|----------------|
|             | Row address         | Column address |
| EDD2516AMTA | AX0 to AX12         | AY0 to AY8     |

**A10 (AP) (input pin)**

A10 defines the precharge mode when a precharge command, a read command or a write command is issued. If A10 = High when a precharge command is issued, all banks are precharged. If A10 = Low when a precharge command is issued, only the bank that is selected by BA1/BA0 is precharged. If A10 = High when read or write command, auto-precharge function is enabled. While A10 = Low, auto-precharge function is disabled.

**BA0 and BA1 (input pins)**

BA0, BA1 are bank select signals (BA). The memory array is divided into bank 0, bank 1, bank 2 and bank 3. (See Bank Select Signal Table)

**[Bank Select Signal Table]**

|        | BA0 | BA1 |
|--------|-----|-----|
| Bank 0 | L   | L   |
| Bank 1 | H   | L   |
| Bank 2 | L   | H   |
| Bank 3 | H   | H   |

Remark: H: VIH. L: VIL.

[查询 EDD2516AMTA-6B-E"供应商](#)

**CKE (input pin)**  
This pin determines whether or not the next CK is valid. If CKE is High, the next CK rising edge is valid. If CKE is Low, CKE controls power down and self-refresh. The power down and the self-refresh commands are entered when the CKE is driven Low and exited when it resumes to High. CKE must be maintained high throughout read or write access.

The CKE level must be kept for 1 CK cycle at least, that is, if CKE changes at the cross point of the CK rising edge and the /CK falling edge with proper setup time t<sub>IS</sub>, by the next CK rising edge CKE level must be kept with proper hold time t<sub>IH</sub>.

**UDM, LDM (input pin)**

DMs are the reference signals of the data input mask function. DMs are sampled at the cross point of DQS and VREF. DMs provide the byte mask function. In ×16 products, LDM controls the lower byte (DQ0 to DQ7) and UDM controls the upper byte (DQ8 to DQ15) of write data. When DM = High, the data input at the same timing are masked while the internal burst counter will be count up. LDM controls the lower byte (DQ0 to DQ7) and UDM controls the upper byte (DQ8 to DQ15) of write data.

**DQ0 to DQ15 (input/output pins)**

Data is input to and output from these pins.

**UDQS, LDQS (input and output pin):** DQS provide the read data strobes (as output) and the write data strobes (as input). In ×16 products, LDQS is the lower byte (DQ0 to DQ7) data strobe signal, UDQS is the upper byte (DQ8 to DQ15) data strobe signal.

**VDD, VSS, VDDQ, VSSQ (Power supply)**

VDD and VSS are power supply pins for internal circuits. VDDQ and VSSQ are power supply pins for the output buffers.

Product

查询"EDD2516AMTA-6B-E"供应商  
Command Operation

**Command Truth Table**

DDR SDRAM recognize the following commands specified by the /CS, /RAS, /CAS, /WE and address pins. All other combinations than those in the table below are illegal.

| Command                            | Symbol | CKE |   | /CS | /RAS | /CAS | /WE | BA1 | BA0 | AP | Address |
|------------------------------------|--------|-----|---|-----|------|------|-----|-----|-----|----|---------|
|                                    |        | n-1 | n |     |      |      |     |     |     |    |         |
| Ignore command                     | DESL   | H   | H | H   | x    | x    | x   | x   | x   | x  | x       |
| No operation                       | NOP    | H   | H | L   | H    | H    | H   | x   | x   | x  | x       |
| Burst stop in read command         | BST    | H   | H | L   | H    | H    | L   | x   | x   | x  | x       |
| Column address and read command    | READ   | H   | H | L   | H    | L    | H   | V   | V   | L  | V       |
| Read with auto-precharge           | READA  | H   | H | L   | H    | L    | H   | V   | V   | H  | V       |
| Column address and write command   | WRIT   | H   | H | L   | H    | L    | L   | V   | V   | L  | V       |
| Write with auto-precharge          | WRITA  | H   | H | L   | H    | L    | L   | V   | V   | H  | V       |
| Row address strobe and bank active | ACT    | H   | H | L   | L    | H    | H   | V   | V   | V  | V       |
| Precharge select bank              | PRE    | H   | H | L   | L    | H    | L   | V   | V   | L  | x       |
| Precharge all bank                 | PALL   | H   | H | L   | L    | H    | L   | x   | x   | H  | x       |
| Refresh                            | REF    | H   | H | L   | L    | L    | H   | x   | x   | x  | x       |
|                                    | SELF   | H   | L | L   | L    | L    | H   | x   | x   | x  | x       |
| Mode register set                  | MRS    | H   | H | L   | L    | L    | L   | L   | L   | L  | V       |
|                                    | EMRS   | H   | H | L   | L    | L    | L   | L   | H   | L  | V       |

Remark: H: VIH. L: VIL. x: VIH or VIL V: Valid address input

Note: The CKE level must be kept for 1 CK cycle at least.

**Ignore command [DESL]**

When /CS is High at the cross point of the CK rising edge and the VREF level, every input are neglected and internal status is held.

**No operation [NOP]**

As long as this command is input at the cross point of the CK rising edge and the VREF level, address and data input are neglected and internal status is held.

**Burst stop in read operation [BST]**

This command stops a burst read operation, which is not applicable for a burst write operation.

**Column address strobe and read command [READ]**

This command starts a read operation. The start address of the burst read is determined by the column address (See "Address Pins Table" in Pin Function) and the bank select address. After the completion of the read operation, the output buffer becomes High-Z.

**Read with auto-precharge [READA]**

This command starts a read operation. After completion of the read operation, precharge is automatically executed.

**Column address strobe and write command [WRIT]**

This command starts a write operation. The start address of the burst write is determined by the column address (See "Address Pins Table" in Pin Function) and the bank select address.

**Write with auto-precharge [WRITA]**

This command starts a write operation. After completion of the write operation, precharge is automatically executed.

**Row address strobe and bank activate [ACT]**

This command activates the bank that is selected by BA0, BA1 and determines the row address (AX0 to AX12). (See Bank Select Signal Table)

**Precharge selected bank [PRE]**

This command starts precharge operation for the bank selected by BA0, BA1. (See Bank Select Signal Table)

**[Bank Select Signal Table]**

|        | BA0 | BA1 |
|--------|-----|-----|
| Bank 0 | L   | L   |
| Bank 1 | H   | L   |
| Bank 2 | L   | H   |
| Bank 3 | H   | H   |

Remark: H: VIH. L: VIL.

**Precharge all banks [PALL]**

This command starts a precharge operation for all banks.

**Refresh [REF/SELF]**

This command starts a refresh operation. There are two types of refresh operation, one is auto-refresh, and another is self-refresh. For details, refer to the CKE truth table section.

**Mode register set/Extended mode register set [MRS/EMRS]**

The DDR SDRAM has the two mode registers, the mode register and the extended mode register, to defines how it works. The both mode registers are set through the address pins (the A0 to the A12, BA0 to BA1) in the mode register set cycle. For details, refer to "Mode register and extended mode register set".

**CKE Truth Table**

| Current state | Command                    | CKE   |   | /CS | /RAS | /CAS | /WE | Address | Notes |
|---------------|----------------------------|-------|---|-----|------|------|-----|---------|-------|
|               |                            | n - 1 | n |     |      |      |     |         |       |
| Idle          | Auto-refresh command (REF) | H     | H | L   | L    | L    | H   | ×       | 2     |
| Idle          | Self-refresh entry (SELF)  | H     | L | L   | L    | L    | H   | ×       | 2     |
| Idle          | Power down entry (PDEN)    | H     | L | L   | H    | H    | H   | ×       |       |
|               |                            | H     | L | H   | ×    | ×    | ×   | ×       |       |
| Self refresh  | Self refresh exit (SELFX)  | L     | H | L   | H    | H    | H   | ×       |       |
|               |                            | L     | H | H   | ×    | ×    | ×   | ×       |       |
| Power down    | Power down exit (PDEX)     | L     | H | L   | H    | H    | H   | ×       |       |
|               |                            | L     | H | H   | ×    | ×    | ×   | ×       |       |

Remark: H: VIH. L: VIL. ×: VIH or VIL.

Notes: 1. All the banks must be in IDLE before executing this command.

2. The CKE level must be kept for 1 CK cycle at least.

查询"EDD2516AMTA-6B-E"供应商  
Function Truth Table

The following tables show the operations that are performed when each command is issued in each state of the DDR SDRAM.

| Current state                           | /CS                      | /RAS | /CAS | /WE | Address     | Command    | Operation                               | Next state                          |        |
|---|--------------------------|------|------|-----|-------------|------------|---|-------------------------------------|--------|
| Precharging* <sup>1</sup>               | H                        | x    | x    | x   | x           | DESL       | NOP                                     | Idle                                |        |
|   | L                        | H    | H    | H   | x           | NOP        | NOP                                     | Idle                                |        |
|   | L                        | H    | H    | L   | x           | BST        | ILLEGAL* <sup>11</sup>                  | —                                   |        |
|   | L                        | H    | L    | H   | BA, CA, A10 | READ/READA | ILLEGAL* <sup>11</sup>                  | —                                   |        |
|   | L                        | H    | L    | L   | BA, CA, A10 | WRIT/WRITA | ILLEGAL* <sup>11</sup>                  | —                                   |        |
|   | L                        | L    | H    | H   | BA, RA      | ACT        | ILLEGAL* <sup>11</sup>                  | —                                   |        |
|   | L                        | L    | H    | L   | BA, A10     | PRE, PALL  | NOP                                     | Idle                                |        |
|   | L                        | L    | L    | x   | x           |            | ILLEGAL                                 | —                                   |        |
| Idle* <sup>2</sup>                      | H                        | x    | x    | x   | x           | DESL       | NOP                                     | Idle                                |        |
|   | L                        | H    | H    | H   | x           | NOP        | NOP                                     | Idle                                |        |
|   | L                        | H    | H    | L   | x           | BST        | ILLEGAL* <sup>11</sup>                  | —                                   |        |
|   | L                        | H    | L    | H   | BA, CA, A10 | READ/READA | ILLEGAL* <sup>11</sup>                  | —                                   |        |
|   | L                        | H    | L    | L   | BA, CA, A10 | WRIT/WRITA | ILLEGAL* <sup>11</sup>                  | —                                   |        |
|   | L                        | L    | H    | H   | BA, RA      | ACT        | Activating                              | Active                              |        |
|   | L                        | L    | H    | L   | BA, A10     | PRE, PALL  | NOP                                     | Idle                                |        |
|   | L                        | L    | L    | H   | x           | REF, SELF  | Refresh/<br>Self refresh* <sup>12</sup> | Idle/<br>Self refresh               |        |
| Refresh<br>(auto-refresh)* <sup>3</sup> | L                        | L    | L    | L   | MODE        | MRS        | Mode register set* <sup>12</sup>        | Idle                                |        |
|   | H                        | x    | x    | x   | x           | DESL       | NOP                                     | Idle                                |        |
|   | L                        | H    | H    | H   | x           | NOP        | NOP                                     | Idle                                |        |
|   | L                        | H    | H    | L   | x           | BST        | ILLEGAL                                 | —                                   |        |
|   | L                        | H    | L    | x   | x           |            | ILLEGAL                                 | —                                   |        |
|   | L                        | L    | x    | x   | x           |            | ILLEGAL                                 | —                                   |        |
|   | Activating* <sup>4</sup> | L    | L    | x   | x           | x          |   | ILLEGAL                             | —      |
|   |                          | H    | x    | x   | x           | x          | DESL                                    | NOP                                 | Active |
| L                                       |                          | H    | H    | H   | x           | NOP        | NOP                                     | Active                              |        |
| L                                       |                          | H    | H    | L   | x           | BST        | ILLEGAL* <sup>11</sup>                  | —                                   |        |
| L                                       |                          | H    | L    | H   | BA, CA, A10 | READ/READA | ILLEGAL* <sup>11</sup>                  | —                                   |        |
| L                                       |                          | H    | L    | L   | BA, CA, A10 | WRIT/WRITA | ILLEGAL* <sup>11</sup>                  | —                                   |        |
| L                                       |                          | L    | H    | H   | BA, RA      | ACT        | ILLEGAL* <sup>11</sup>                  | —                                   |        |
| L                                       |                          | L    | H    | L   | BA, A10     | PRE, PALL  | ILLEGAL* <sup>11</sup>                  | —                                   |        |
| Active* <sup>5</sup>                    | L                        | L    | L    | x   | x           |            | ILLEGAL                                 | —                                   |        |
|   | H                        | x    | x    | x   | x           | DESL       | NOP                                     | Active                              |        |
|   | L                        | H    | H    | H   | x           | NOP        | NOP                                     | Active                              |        |
|   | L                        | H    | H    | L   | x           | BST        | ILLEGAL                                 | Active                              |        |
|   | L                        | H    | L    | H   | BA, CA, A10 | READ/READA | Starting read operation                 | Read/READA                          |        |
|   | L                        | H    | L    | L   | BA, CA, A10 | WRIT/WRITA | Starting write operation                | Write<br>recovering/<br>precharging |        |
|   | L                        | L    | H    | H   | BA, RA      | ACT        | ILLEGAL* <sup>11</sup>                  | —                                   |        |
|   | L                        | L    | H    | L   | BA, A10     | PRE, PALL  | Pre-charge                              | Idle                                |        |
| L                                       | L                        | L    | x    | x   |             | ILLEGAL    | —                                       |                                     |        |



查询“EDD2516AMTA-6B-E”供应商

| Current state                           | CS | FS | CS | WE | Address     | Command    | Operation  | Next state       |
|---|----|----|----|----|-------------|------------|--|------------------|
| Read* <sup>6</sup>                      | H  | x  | x  | x  | x           | DESL       | NOP  | Active           |
|   | L  | H  | H  | H  | x           | NOP        | NOP  | Active           |
|   | L  | H  | H  | L  | x           | BST        | BST  | Active           |
|   | L  | H  | L  | H  | BA, CA, A10 | READ/READA | Interrupting burst read operation to start new read              | Active           |
|   | L  | H  | L  | L  | BA, CA, A10 | WRIT/WRITA | ILLEGAL* <sup>13</sup>   | —                |
|   | L  | L  | H  | H  | BA, RA      | ACT        | ILLEGAL* <sup>11</sup>   | —                |
|   | L  | L  | H  | L  | BA, A10     | PRE, PALL  | Interrupting burst read operation to start pre-charge            | Precharging      |
|   | L  | L  | L  | x  | x           |            | ILLEGAL  | —                |
| Read with auto-pre-charge* <sup>7</sup> | H  | x  | x  | x  | x           | DESL       | NOP  | Precharging      |
|   | L  | H  | H  | H  | x           | NOP        | NOP  | Precharging      |
|   | L  | H  | H  | L  | x           | BST        | ILLEGAL  | —                |
|   | L  | H  | L  | H  | BA, CA, A10 | READ/READA | ILLEGAL* <sup>14</sup>   | —                |
|   | L  | H  | L  | L  | BA, CA, A10 | WRIT/WRITA | ILLEGAL* <sup>14</sup>   | —                |
|   | L  | L  | H  | H  | BA, RA      | ACT        | ILLEGAL* <sup>11, 14</sup>                                       | —                |
|   | L  | L  | H  | L  | BA, A10     | PRE, PALL  | ILLEGAL* <sup>11, 14</sup>                                       | —                |
|   | L  | L  | L  | x  | x           |            | ILLEGAL  | —                |
| Write* <sup>8</sup>                     | H  | x  | x  | x  | x           | DESL       | NOP  | Write recovering |
|   | L  | H  | H  | H  | x           | NOP        | NOP  | Write recovering |
|   | L  | H  | H  | L  | x           | BST        | ILLEGAL  | —                |
|   | L  | H  | L  | H  | BA, CA, A10 | READ/READA | Interrupting burst write operation to start read operation.      | Read/ReadA       |
|   | L  | H  | L  | L  | BA, CA, A10 | WRIT/WRITA | Interrupting burst write operation to start new write operation. | Write/WriteA     |
|   | L  | L  | H  | H  | BA, RA      | ACT        | ILLEGAL* <sup>11</sup>   | —                |
|   | L  | L  | H  | L  | BA, A10     | PRE, PALL  | Interrupting write operation to start pre-charge.                | Idle             |
|   | L  | L  | L  | x  | x           |            | ILLEGAL  | —                |
| Write recovering* <sup>9</sup>          | H  | x  | x  | x  | x           | DESL       | NOP  | Active           |
|   | L  | H  | H  | H  | x           | NOP        | NOP  | Active           |
|   | L  | H  | H  | L  | x           | BST        | ILLEGAL  | —                |
|   | L  | H  | L  | H  | BA, CA, A10 | READ/READA | Starting read operation.   | Read/ReadA       |
|   | L  | H  | L  | L  | BA, CA, A10 | WRIT/WRITA | Starting new write operation.                                    | Write/WriteA     |
|   | L  | L  | H  | H  | BA, RA      | ACT        | ILLEGAL* <sup>11</sup>   | —                |
|   | L  | L  | H  | L  | BA, A10     | PRE/PALL   | ILLEGAL* <sup>11</sup>   | —                |
|   | L  | L  | L  | x  | x           |            | ILLEGAL  | —                |

查询"EDD2516AMTA-6B-E"供应商

| Current state                 | /CS | /RAS | /CAS | /WE | Address     | Command     | Operation      | Next state  |
|-------------------------------|-----|------|------|-----|-------------|-------------|----------------|-------------|
| Write with auto-pre-charge*10 | H   | ×    | ×    | ×   | ×           | DESL        | NOP            | Precharging |
|                               | L   | H    | H    | H   | ×           | NOP         | NOP            | Precharging |
|                               | L   | H    | H    | L   | ×           | BST         | ILLEGAL        | —           |
|                               | L   | H    | L    | H   | BA, CA, A10 | READ/READA  | ILLEGAL*14     | —           |
|                               | L   | H    | L    | L   | BA, CA, A10 | WRIT/WRIT A | ILLEGAL*14     | —           |
|                               | L   | L    | H    | H   | BA, RA      | ACT         | ILLEGAL*11, 14 | —           |
|                               | L   | L    | H    | L   | BA, A10     | PRE, PALL   | ILLEGAL*11, 14 | —           |
|                               | L   | L    | L    | ×   | ×           |             | ILLEGAL        | —           |

Remark: H: VIH. L: VIL. ×: VIH or VIL

- Notes:
- The DDR SDRAM is in "Precharging" state for tRP after precharge command is issued.
  - The DDR SDRAM reaches "IDLE" state tRP after precharge command is issued.
  - The DDR SDRAM is in "Refresh" state for tRFC after auto-refresh command is issued.
  - The DDR SDRAM is in "Activating" state for tRCD after ACT command is issued.
  - The DDR SDRAM is in "Active" state after "Activating" is completed.
  - The DDR SDRAM is in "READ" state until burst data have been output and DQ output circuits are turned off.
  - The DDR SDRAM is in "READ with auto-precharge" from READA command until burst data has been output and DQ output circuits are turned off.
  - The DDR SDRAM is in "WRITE" state from WRIT command to the last burst data are input.
  - The DDR SDRAM is in "Write recovering" for tWR after the last data are input.
  - The DDR SDRAM is in "Write with auto-precharge" until tWR after the last data has been input.
  - This command may be issued for other banks, depending on the state of the banks.
  - All banks must be in "IDLE".
  - Before executing a write command to stop the preceding burst read operation, BST command must be issued.
  - The DDR SDRAM supports the concurrent auto-precharge feature, a read with auto-precharge enabled, or a write with auto-precharge enabled, may be followed by any column command to other banks, as long as that command does not interrupt the read or write data transfer, and all other related limitations apply. (E.g. Conflict between READ data and WRITE data must be avoided.)

The minimum delay from a read or write command with auto precharge enabled, to a command to a different bank, is summarized below.

| From command | To command (different bank, non-interrupting command) | Minimum delay (Concurrent AP supported) | Units |
|--------------|---|---|-------|
| Read w/AP    | Read or Read w/AP                                     | BL/2                                    | tCK   |
|              | Write or Write w/AP                                   | CL(rounded up)+ (BL/2)                  | tCK   |
|              | Precharge or Activate                                 | 1                                       | tCK   |
| Write w/AP   | Read or Read w/AP                                     | 1 + (BL/2) + tWTR                       | tCK   |
|              | Write or Write w/AP                                   | BL/2                                    | tCK   |
|              | Precharge or Activate                                 | 1                                       | tCK   |

查询"EDD2516AMTA-6B-E"供应商  
Command Truth Table for CKE

| Current State         | CKE        |   |     |      |      |     |         | Operation                                   | Notes                                       |   |
|-----------------------|------------|---|-----|------|------|-----|---------|---|---|---|
|                       | n-1        | n | /CS | /RAS | /CAS | /WE | Address |   |   |   |
| Self refresh          | H          | x | x   | x    | x    | x   | x       | INVALID, CK (n-1) would exit self refresh   |   |   |
|                       | L          | H | H   | x    | x    | x   | x       | Self refresh recovery                       |   |   |
|                       | L          | H | L   | H    | H    | x   | x       | Self refresh recovery                       |   |   |
|                       | L          | H | L   | H    | L    | x   | x       | ILLEGAL                                     |   |   |
|                       | L          | H | L   | L    | x    | x   | x       | ILLEGAL                                     |   |   |
|                       | L          | L | x   | x    | x    | x   | x       | Maintain self refresh                       |   |   |
| Self refresh recovery | H          | H | H   | x    | x    | x   | x       | Idle after tRC                              |   |   |
|                       | H          | H | L   | H    | H    | x   | x       | Idle after tRC                              |   |   |
|                       | H          | H | L   | H    | L    | x   | x       | ILLEGAL                                     |   |   |
|                       | H          | H | L   | L    | x    | x   | x       | ILLEGAL                                     |   |   |
|                       | H          | L | H   | x    | x    | x   | x       | ILLEGAL                                     |   |   |
|                       | H          | L | L   | H    | H    | x   | x       | ILLEGAL                                     |   |   |
|                       | H          | L | L   | H    | L    | x   | x       | ILLEGAL                                     |   |   |
|                       | H          | L | L   | L    | x    | x   | x       | ILLEGAL                                     |   |   |
| Power down            | H          | x | x   | x    | x    | x   |         | INVALID, CK (n-1) would exit power down     |   |   |
|                       | L          | H | H   | x    | x    | x   | x       | EXIT power down → Idle                      |   |   |
|                       | L          | H | L   | H    | H    | H   | x       |   |   |   |
|                       | L          | L | x   | x    | x    | x   | x       | Maintain power down mode                    |   |   |
| All banks idle        | H          | H | H   | x    | x    | x   |         | Refer to operations in Function Truth Table |   |   |
|                       | H          | H | L   | H    | x    | x   |         | Refer to operations in Function Truth Table |   |   |
|                       | H          | H | L   | L    | H    | x   |         | Refer to operations in Function Truth Table |   |   |
|                       | H          | H | L   | L    | L    | H   | x       | CBR (auto) refresh                          |   |   |
|                       | H          | H | L   | L    | L    | L   | OPCODE  | Refer to operations in Function Truth Table |   |   |
|                       | H          | L | H   | x    | x    | x   |         | Refer to operations in Function Truth Table |   |   |
|                       | H          | L | L   | H    | x    | x   |         | Refer to operations in Function Truth Table |   |   |
|                       | H          | L | L   | L    | H    | x   |         | Refer to operations in Function Truth Table |   |   |
|                       | H          | L | L   | L    | L    | H   | x       | Self refresh                                | 1   |   |
|                       | H          | L | L   | L    | L    | L   | OPCODE  | Refer to operations in Function Truth Table |   |   |
|                       | L          | x | x   | x    | x    | x   | x       | Power down                                  | 1   |   |
|                       | Row active | H | x   | x    | x    | x   | x       | x   | Refer to operations in Function Truth Table |   |
|                       |            | L | x   | x    | x    | x   | x       | x   | Power down                                  | 1 |

Remark: H: VIH. L: VIL. x: VIH or VIL

Note: 1. Self refresh can be entered only from the all banks idle state. Power down can be entered only from all banks idle or row active state.

[查询"EDD2516AMTA-6B-E"供应商](#)

**Auto-refresh command [REF]**  
 This command executes auto-refresh. The banks and the ROW addresses to be refreshed are internally determined by the internal refresh controller. The average refresh cycle is 7.8  $\mu$ s. The output buffer becomes High-Z after auto-refresh start. Precharge has been completed automatically after the auto-refresh. The ACT or MRS command can be issued tRFC after the last auto-refresh command.

**Self-refresh entry [SELF]**

This command starts self-refresh. The self-refresh operation continues as long as CKE is held Low. During the self-refresh operation, all ROW addresses are repeated refreshing by the internal refresh controller. A self-refresh is terminated by a self-refresh exit command.

**Power down mode entry [PDEN]**

tPDEN (= 1 cycle) after the cycle when [PDEN] is issued. The DDR SDRAM enters into power-down mode. In power down mode, power consumption is suppressed by deactivating the input initial circuit. Power down mode continues while CKE is held Low. No internal refresh operation occurs during the power down mode. [PDEN] do not disable DLL.

**Self-refresh exit [SELFX]**

This command is executed to exit from self-refresh mode. To issue non-read commands, tSNR has to be satisfied. ((tSNR =)10 cycles for tCK = 7.5 ns or 12 cycles for tCK = 6.0 ns after [SELFX]) To issue read command, tSRD has to be satisfied to adjust DOUT timing by DLL. (200 cycles after [SELFX]) After the exit, input auto-refresh command within 7.8  $\mu$ s.

**Power down exit [PDEX]**

The DDR SDRAM can exit from power down mode tPDEX (1 cycle min.) after the cycle when [PDEX] is issued.



查询"EDD2516AMTA-6B-E"供应商  
Simplified State Diagram

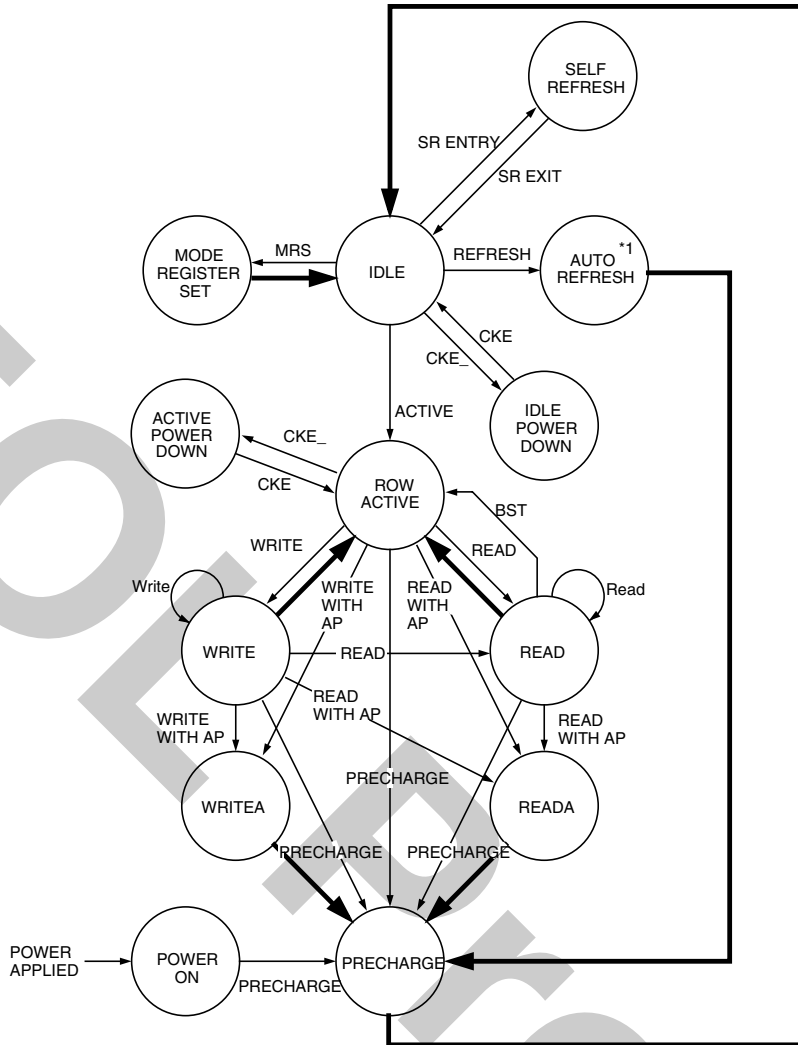

- ➡ Automatic transition after completion of command.
- Transition resulting from command input.

Note: 1. After the auto-refresh operation, precharge operation is performed automatically and enter the IDLE state.

**Power-up Sequence**

The following sequence is recommended for Power-up.

- (1) Apply power and attempt to maintain CKE at an LVCMOS low state (all other inputs may be undefined).  
Apply VDD before or at the same time as VDDQ.  
Apply VDDQ before or at the same time as VTT and VREF.
- (2) Start clock and maintain stable condition for a minimum of 200  $\mu$ s.
- (3) After the minimum 200  $\mu$ s of stable power and clock (CK, /CK), apply NOP and take CKE high.
- (4) Issue precharge all command for the device.
- (5) Issue EMRS to enable DLL.
- (6) Issue a mode register set command (MRS) for "DLL reset" with bit A8 set to high (An additional 200 cycles of clock input is required to lock the DLL after every DLL reset).
- (7) Issue precharge all command for the device.
- (8) Issue 2 or more auto-refresh commands.
- (9) Issue a mode register set command to initialize device operation with bit A8 set to low in order to avoid resetting the DLL.

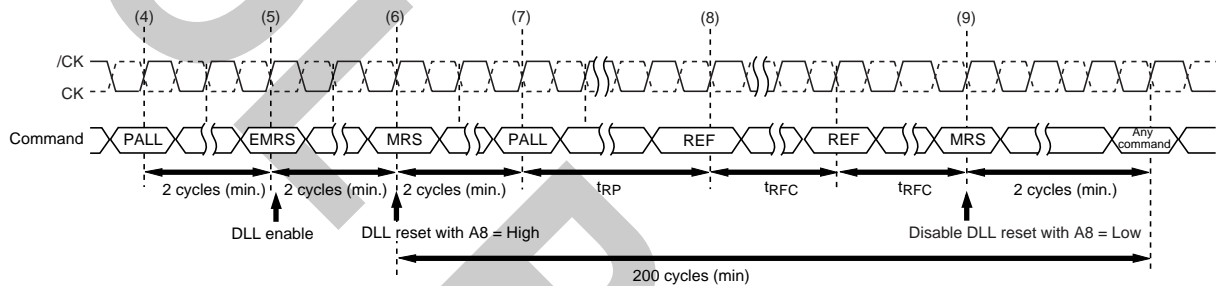

**Power-up Sequence after CKE Goes High**

**Mode Register and Extended Mode Register Set**

There are two mode registers, the mode register and the extended mode register so as to define the operating mode. Parameters are set to both through the A0 to the A12 and BA0, BA1 pins by the mode register set command [MRS] or the extended mode register set command [EMRS]. The mode register and the extended mode register are set by inputting signal via the A0 to the A12 and BA0, BA1 during mode register set cycles. BA0 and BA1 determine which one of the mode register or the extended mode register are set. Prior to a read or a write operation, the mode register must be set.

Remind that no other parameters shown in the table below are allowed to input to the registers.

|     |     |     |     |     |    |    |    |       |    |    |    |    |    |    |
|-----|-----|-----|-----|-----|----|----|----|-------|----|----|----|----|----|----|
| BA0 | BA1 | A12 | A11 | A10 | A9 | A8 | A7 | A6    | A5 | A4 | A3 | A2 | A1 | A0 |
| 0   | 0   | 0   | 0   | 0   | 0  | DR | 0  | LMODE |    | BT | BL |    |    |    |

|     |           |
|-----|-----------|
| MRS |           |
| A8  | DLL Reset |
| 0   | No        |
| 1   | Yes       |

|    |    |    |             |
|----|----|----|-------------|
| A6 | A5 | A4 | CAS Latency |
| 0  | 1  | 0  | 2           |
| 1  | 1  | 0  | 2.5         |

|    |            |
|----|------------|
| A3 | Burst Type |
| 0  | Sequential |
| 1  | Interleave |

|    |    |    |              |      |
|----|----|----|--------------|------|
| A2 | A1 | A0 | Burst Length |      |
|    |    |    | BT=0         | BT=1 |
| 0  | 0  | 1  | 2            | 2    |
| 0  | 1  | 0  | 4            | 4    |
| 0  | 1  | 1  | 8            | 8    |

**Mode Register Set [MRS] (BA0 = 0, BA1 = 0)**

查询"EDD2516AMTA-6B-E"供应商

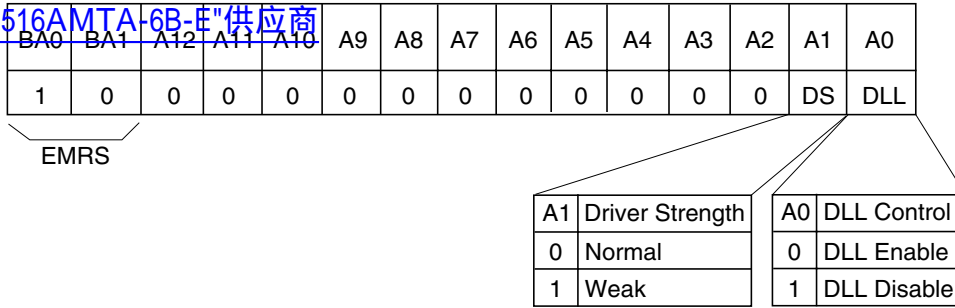

**Extended Mode Register Set [EMRS] (BA0 = 1, BA1 = 0)**

**Burst Operation**

The burst type (BT) and the first three bits of the column address determine the order of a data out.

Burst length = 2

| Starting Ad. | Addressing(decimal) |            |
|--------------|---------------------|------------|
| A0           | Sequence            | Interleave |
| 0            | 0, 1,               | 0, 1,      |
| 1            | 1, 0,               | 1, 0,      |

Burst length = 4

| Starting Ad. |    | Addressing(decimal) |             |
|--------------|----|---------------------|-------------|
| A1           | A0 | Sequence            | Interleave  |
| 0            | 0  | 0, 1, 2, 3,         | 0, 1, 2, 3, |
| 0            | 1  | 1, 2, 3, 0,         | 1, 0, 3, 2, |
| 1            | 0  | 2, 3, 0, 1,         | 2, 3, 0, 1, |
| 1            | 1  | 3, 0, 1, 2,         | 3, 2, 1, 0, |

Burst length = 8

| Starting Ad. |    |    | Addressing(decimal)     |                         |
|--------------|----|----|-------------------------|-------------------------|
| A2           | A1 | A0 | Sequence                | Interleave              |
| 0            | 0  | 0  | 0, 1, 2, 3, 4, 5, 6, 7, | 0, 1, 2, 3, 4, 5, 6, 7, |
| 0            | 0  | 1  | 1, 2, 3, 4, 5, 6, 7, 0, | 1, 0, 3, 2, 5, 4, 7, 6, |
| 0            | 1  | 0  | 2, 3, 4, 5, 6, 7, 0, 1, | 2, 3, 0, 1, 6, 7, 4, 5, |
| 0            | 1  | 1  | 3, 4, 5, 6, 7, 0, 1, 2, | 3, 2, 1, 0, 7, 6, 5, 4, |
| 1            | 0  | 0  | 4, 5, 6, 7, 0, 1, 2, 3, | 4, 5, 6, 7, 0, 1, 2, 3, |
| 1            | 0  | 1  | 5, 6, 7, 0, 1, 2, 3, 4, | 5, 4, 7, 6, 1, 0, 3, 2, |
| 1            | 1  | 0  | 6, 7, 0, 1, 2, 3, 4, 5, | 6, 7, 4, 5, 2, 3, 0, 1, |
| 1            | 1  | 1  | 7, 0, 1, 2, 3, 4, 5, 6, | 7, 6, 5, 4, 3, 2, 1, 0, |

查询"EDD2516AMTA-6B-E"供应商  
Timing Waveforms

Command and Addresses Input Timing Definition

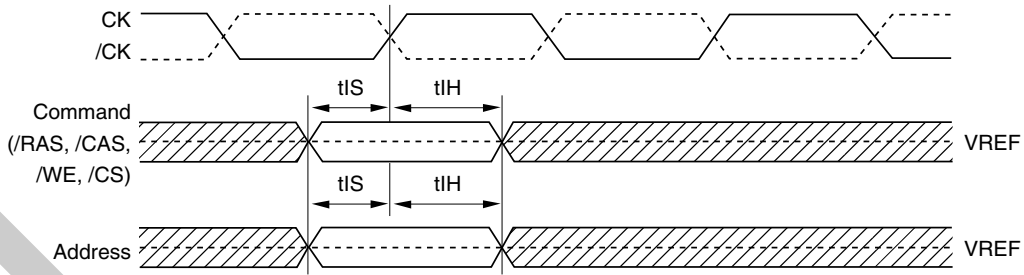

Read Timing Definition

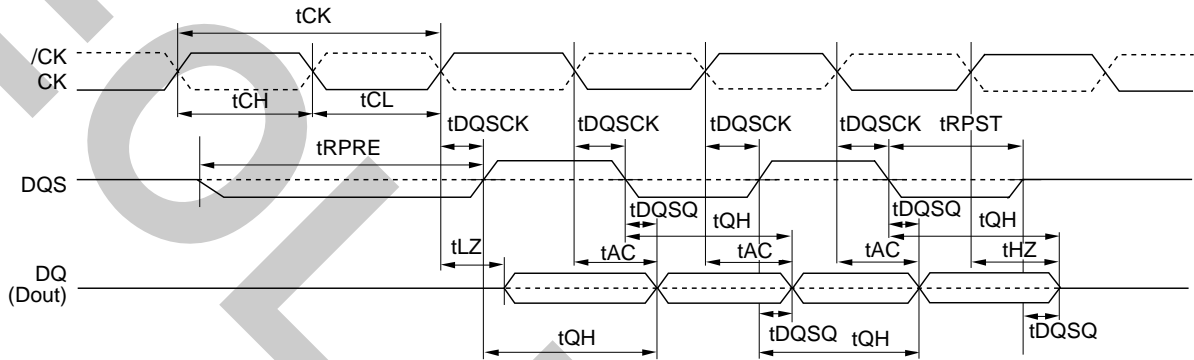

Write Timing Definition

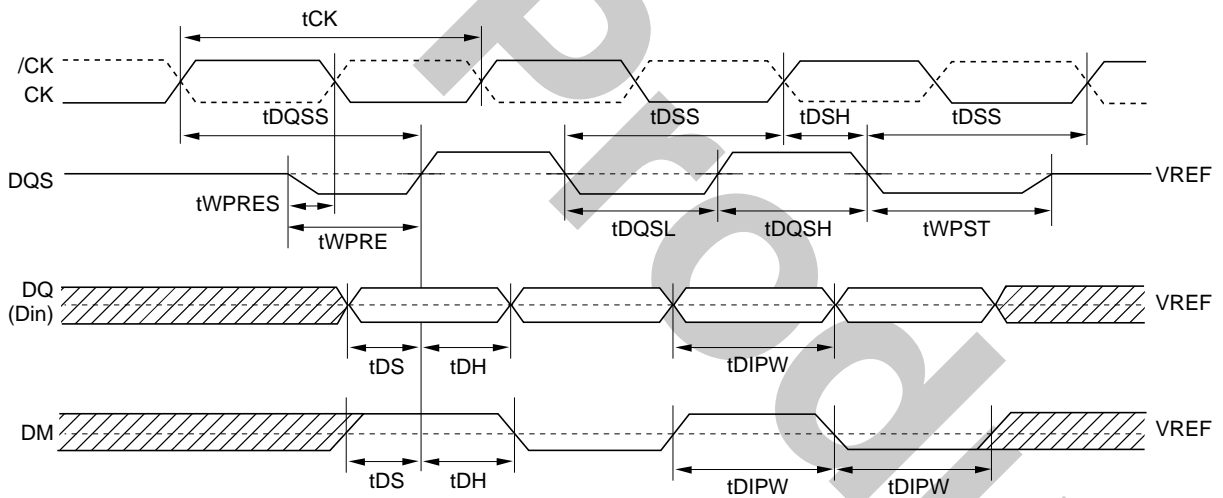



查询"EDD2516AMTA-6B-E"供应商

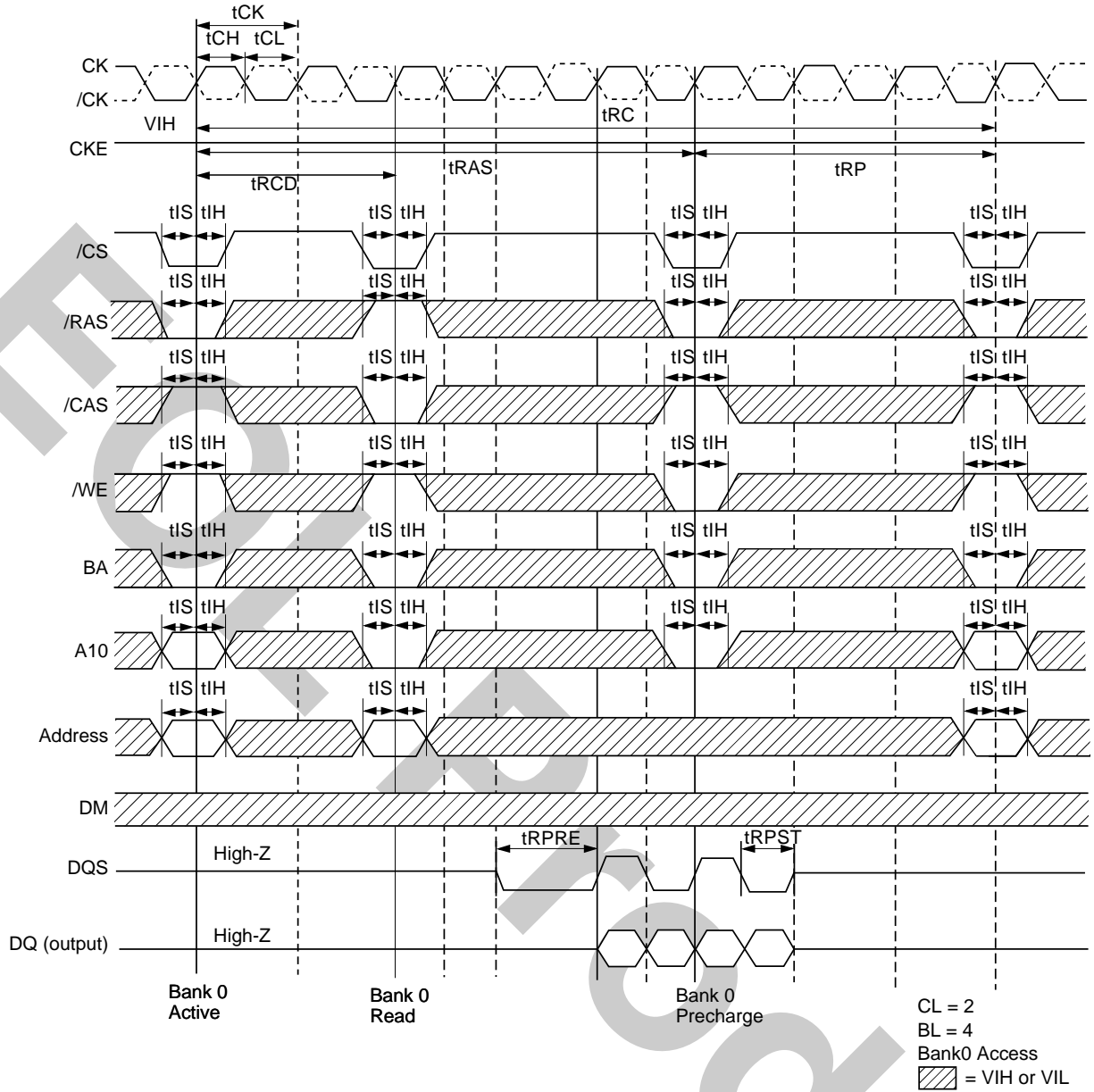

查询"EDD2516AMTA-6B-E"供应商

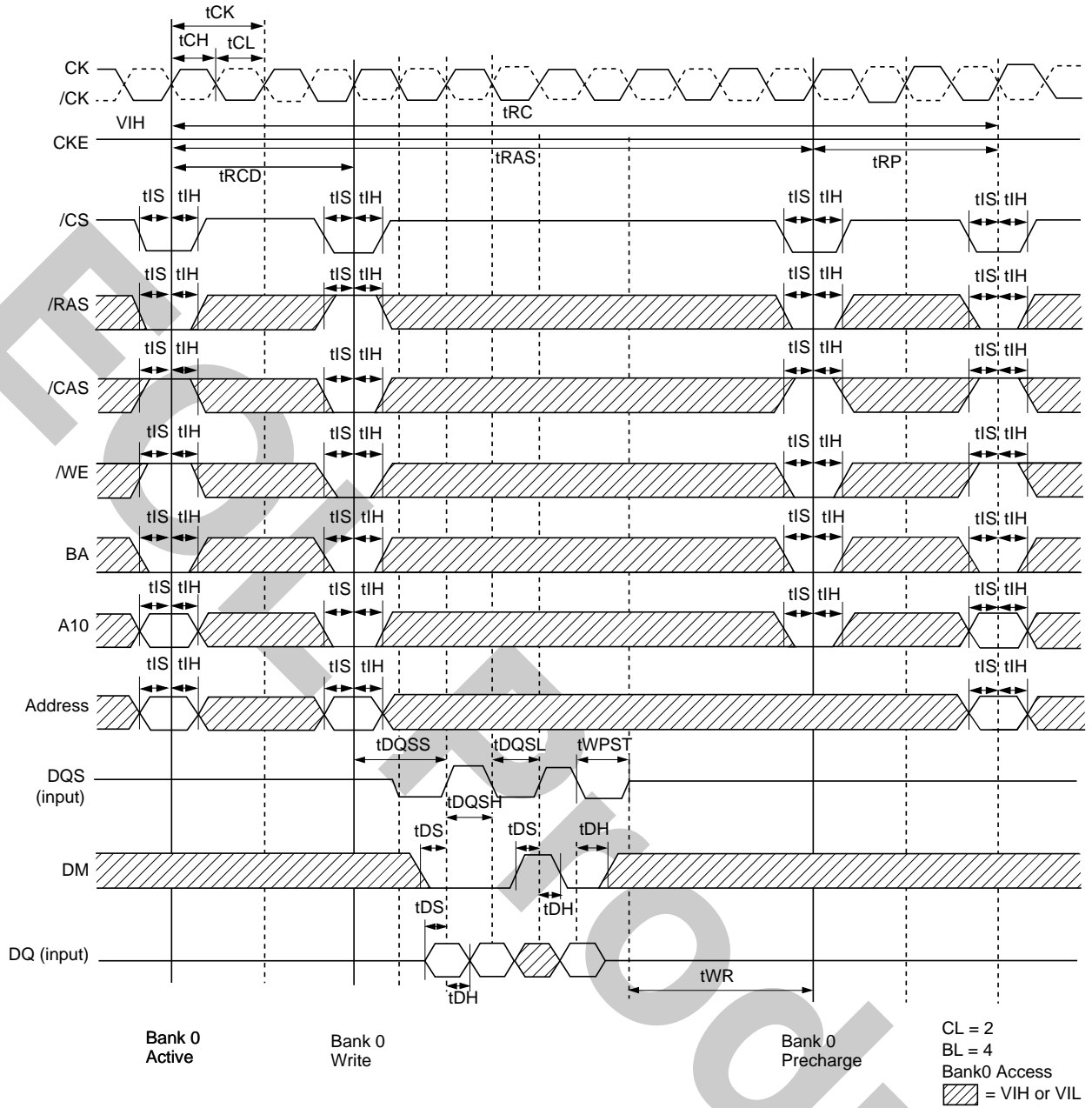

查询"EDD2516AMTA-6B-E"供应商  
Mode Register Set Cycle

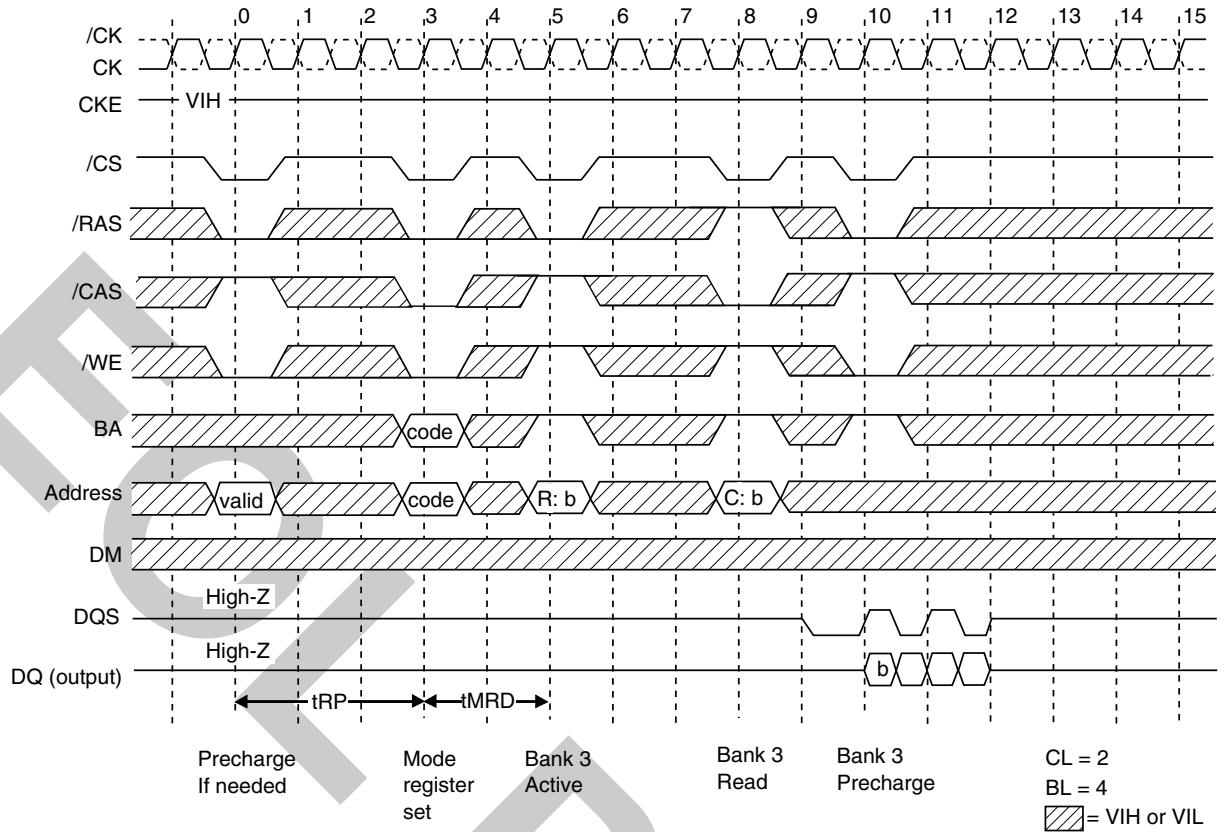

Read/Write Cycle

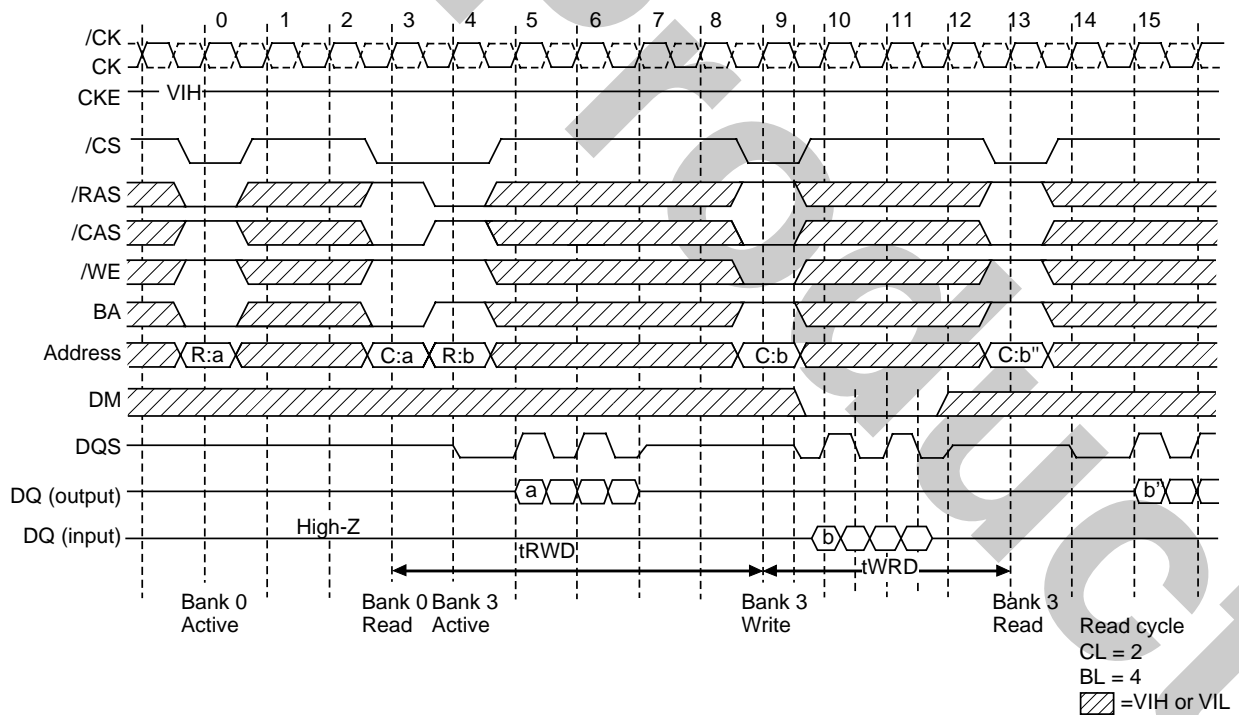

查询"EDD2516AMTA-6B-E"供应商  
Auto Refresh Cycle

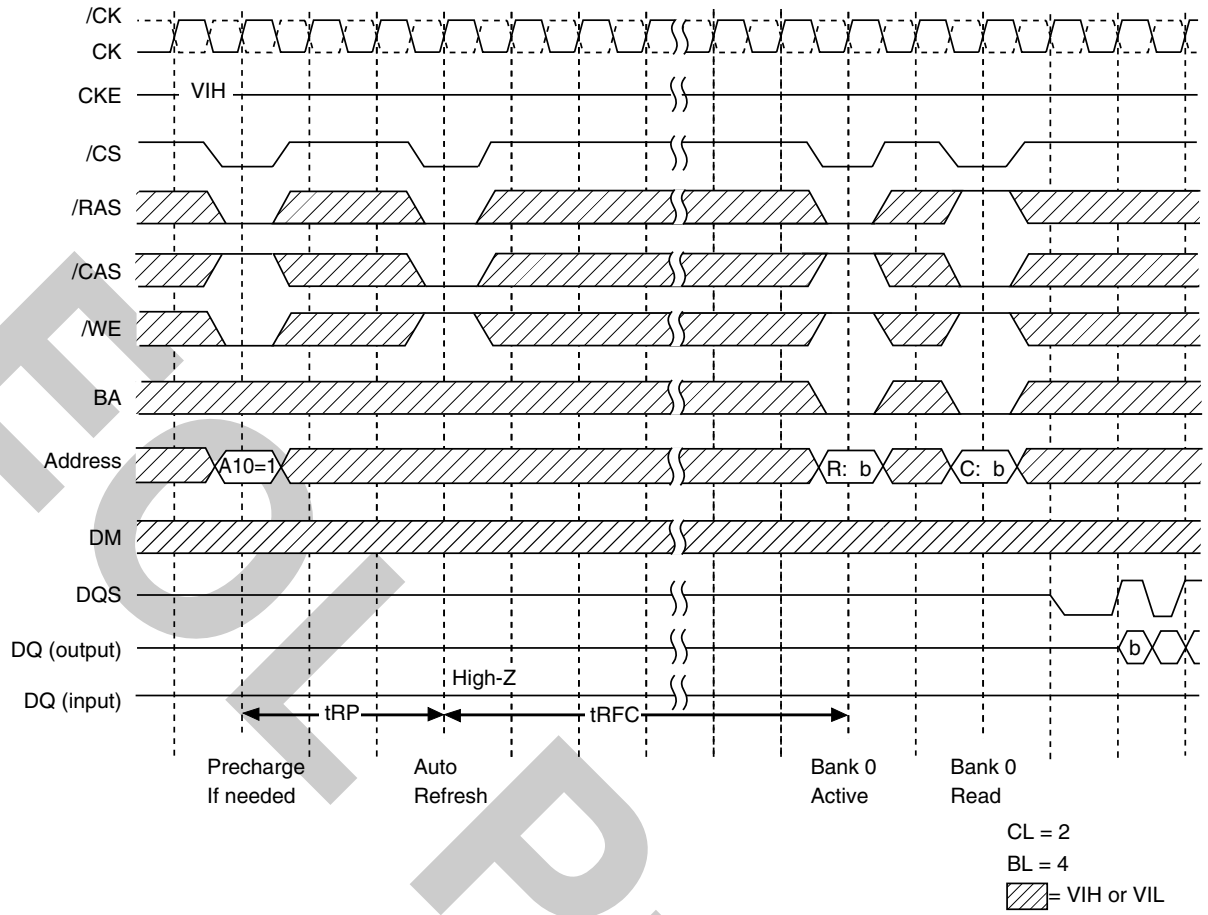

查询"EDD2516AMTA-6B-E"供应商  
Self Refresh Cycle

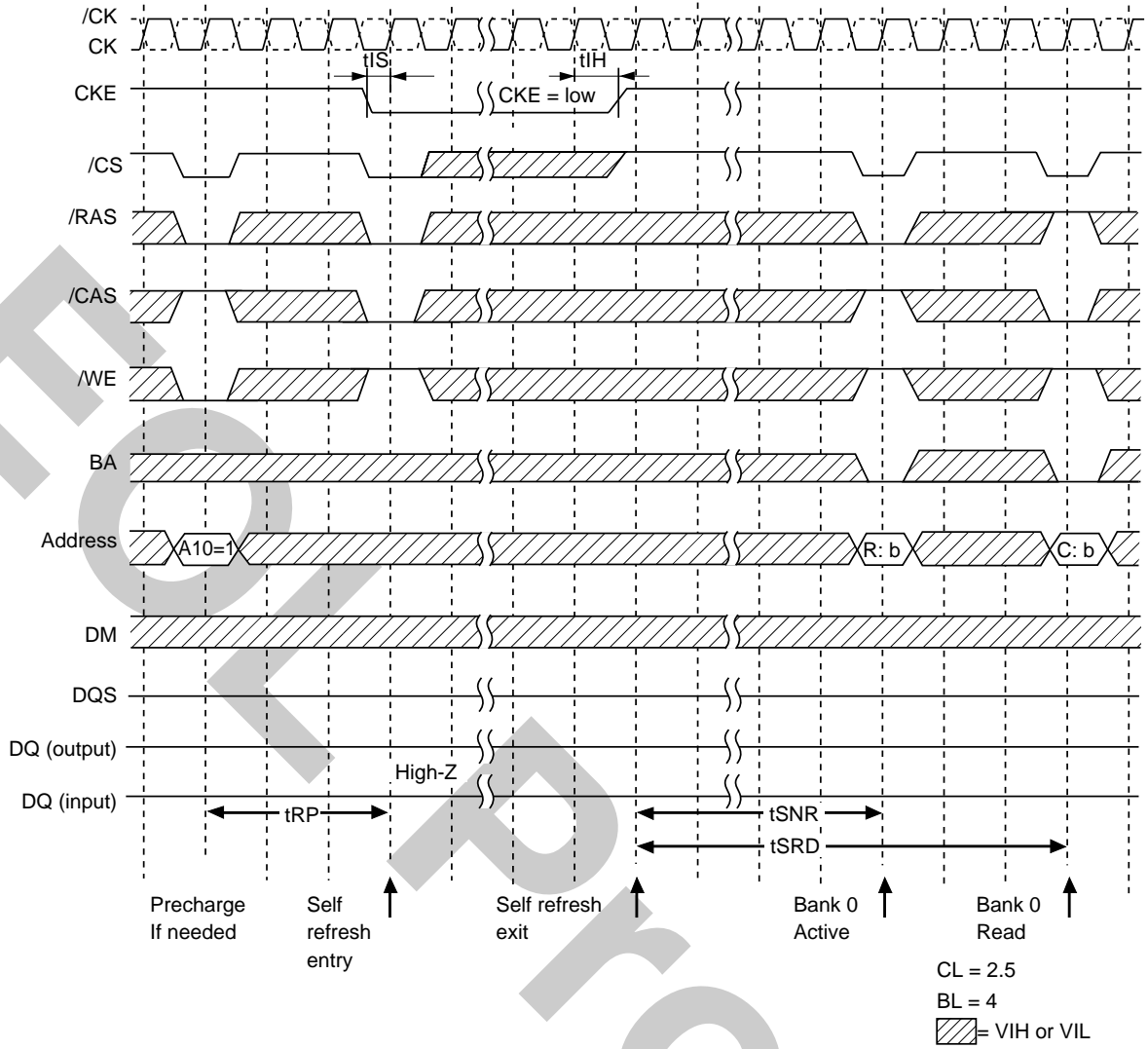

查询"EDD2516AMTA-6B-E"供应商  
Package Drawing

66-pin Plastic TSOP (II)

Solder plating: Lead free (Sn-Bi)

Unit: mm

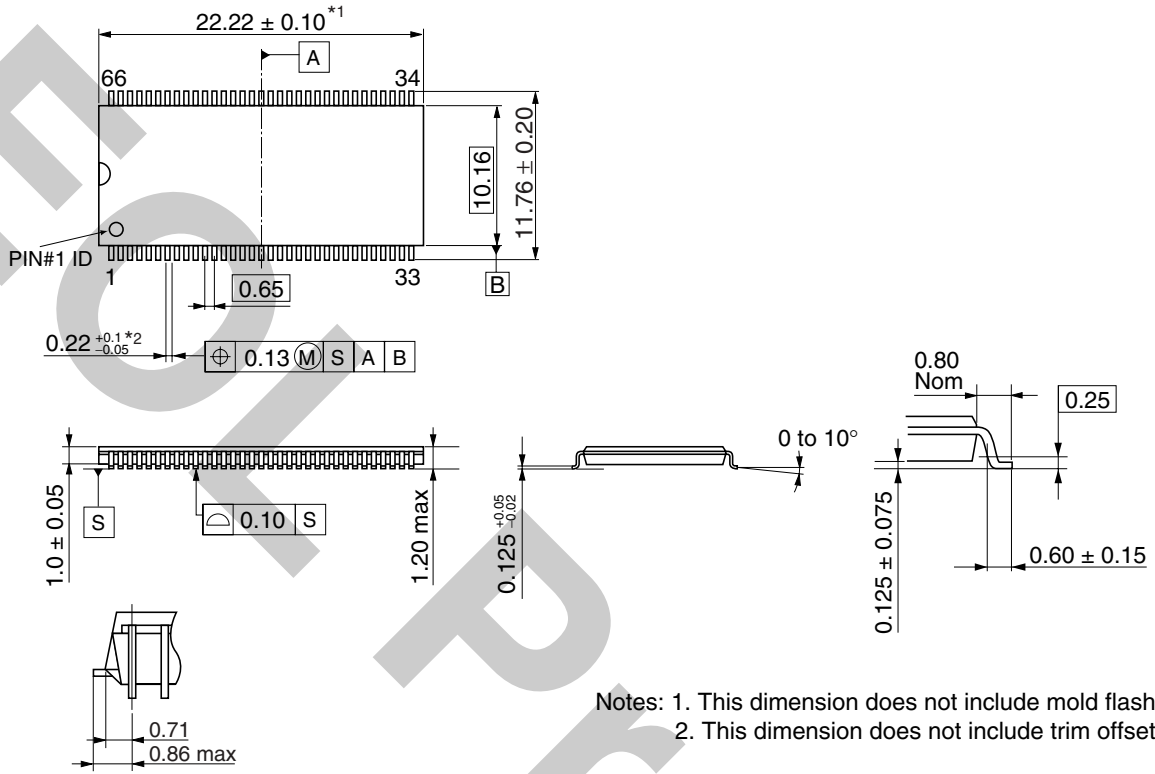

Notes: 1. This dimension does not include mold flash.  
2. This dimension does not include trim offset.

ECA-TS2-0097-01

[查询"EDD2516AMTA-6B-E"供应商](#)  
**Recommended Soldering Conditions**

Please consult with our sales offices for soldering conditions of the EDD2516AMTA.

**Type of Surface Mount Device**

EDD2516AMTA: 66-pin Plastic TSOP (II) < Lead free (Sn-Bi) >

FOR Product

NOTES FOR CMOS DEVICES

① PRECAUTION AGAINST ESD FOR MOS DEVICES

Exposing the MOS devices to a strong electric field can cause destruction of the gate oxide and ultimately degrade the MOS devices operation. Steps must be taken to stop generation of static electricity as much as possible, and quickly dissipate it, when once it has occurred. Environmental control must be adequate. When it is dry, humidifier should be used. It is recommended to avoid using insulators that easily build static electricity. MOS devices must be stored and transported in an anti-static container, static shielding bag or conductive material. All test and measurement tools including work bench and floor should be grounded. The operator should be grounded using wrist strap. MOS devices must not be touched with bare hands. Similar precautions need to be taken for PW boards with semiconductor MOS devices on it.

② HANDLING OF UNUSED INPUT PINS FOR CMOS DEVICES

No connection for CMOS devices input pins can be a cause of malfunction. If no connection is provided to the input pins, it is possible that an internal input level may be generated due to noise, etc., hence causing malfunction. CMOS devices behave differently than Bipolar or NMOS devices. Input levels of CMOS devices must be fixed high or low by using a pull-up or pull-down circuitry. Each unused pin should be connected to  $V_{DD}$  or GND with a resistor, if it is considered to have a possibility of being an output pin. The unused pins must be handled in accordance with the related specifications.

③ STATUS BEFORE INITIALIZATION OF MOS DEVICES

Power-on does not necessarily define initial status of MOS devices. Production process of MOS does not define the initial operation status of the device. Immediately after the power source is turned ON, the MOS devices with reset function have not yet been initialized. Hence, power-on does not guarantee output pin levels, I/O settings or contents of registers. MOS devices are not initialized until the reset signal is received. Reset operation must be executed immediately after power-on for MOS devices having reset function.

CME0107



[查询"EDD2516AMTA-6B-E"供应商](#)

The information in this document is subject to change without notice. Before using this document, confirm that this is the latest version.

No part of this document may be copied or reproduced in any form or by any means without the prior written consent of Elpida Memory, Inc.

Elpida Memory, Inc. does not assume any liability for infringement of any intellectual property rights (including but not limited to patents, copyrights, and circuit layout licenses) of Elpida Memory, Inc. or third parties by or arising from the use of the products or information listed in this document. No license, express, implied or otherwise, is granted under any patents, copyrights or other intellectual property rights of Elpida Memory, Inc. or others.

Descriptions of circuits, software and other related information in this document are provided for illustrative purposes in semiconductor product operation and application examples. The incorporation of these circuits, software and information in the design of the customer's equipment shall be done under the full responsibility of the customer. Elpida Memory, Inc. assumes no responsibility for any losses incurred by customers or third parties arising from the use of these circuits, software and information.

**[Product applications]**

Elpida Memory, Inc. makes every attempt to ensure that its products are of high quality and reliability. However, users are instructed to contact Elpida Memory's sales office before using the product in aerospace, aeronautics, nuclear power, combustion control, transportation, traffic, safety equipment, medical equipment for life support, or other such application in which especially high quality and reliability is demanded or where its failure or malfunction may directly threaten human life or cause risk of bodily injury.

**[Product usage]**

Design your application so that the product is used within the ranges and conditions guaranteed by Elpida Memory, Inc., including the maximum ratings, operating supply voltage range, heat radiation characteristics, installation conditions and other related characteristics. Elpida Memory, Inc. bears no responsibility for failure or damage when the product is used beyond the guaranteed ranges and conditions. Even within the guaranteed ranges and conditions, consider normally foreseeable failure rates or failure modes in semiconductor devices and employ systemic measures such as fail-safes, so that the equipment incorporating Elpida Memory, Inc. products does not cause bodily injury, fire or other consequential damage due to the operation of the Elpida Memory, Inc. product.

**[Usage environment]**

This product is not designed to be resistant to electromagnetic waves or radiation. This product must be used in a non-condensing environment.

If you export the products or technology described in this document that are controlled by the Foreign Exchange and Foreign Trade Law of Japan, you must follow the necessary procedures in accordance with the relevant laws and regulations of Japan. Also, if you export products/technology controlled by U.S. export control regulations, or another country's export control laws or regulations, you must follow the necessary procedures in accordance with such laws or regulations.

If these products/technology are sold, leased, or transferred to a third party, or a third party is granted license to use these products, that third party must be made aware that they are responsible for compliance with the relevant laws and regulations.

M01E0107

**This datasheet has been downloaded from:**

**[www.EEworld.com.cn](http://www.EEworld.com.cn)**

**Free Download**

**Daily Updated Database**

**100% Free Datasheet Search Site**

**100% Free IC Replacement Search Site**

**Convenient Electronic Dictionary**

**Fast Search System**

**[www.EEworld.com.cn](http://www.EEworld.com.cn)**