

108 dB, 192 kHz, Multi-Bit Audio A/D Converter

Features

- Advanced Multi-bit Delta-Sigma Architecture
- 24-Bit Conversion
- 108 dB Dynamic Range
- -98 dB THD+N
- System Sampling Rates up to 192 kHz
- Single-Ended Analog Inputs
- Less than 150 mW Power Consumption
- High Pass Filter or DC Offset Calibration
- Supports Logic Levels Between 5 and 2.5V
- Linear Phase Digital Anti-Alias Filtering
- Overflow Detection
- Functionally Compatible with the CS5361

General Description

The CS5351 is a complete analog-to-digital converter for digital audio systems. It performs sampling, analog-to-digital conversion and anti-alias filtering, generating 24-bit values for both left and right inputs in serial form at sample rates up to 192 kHz per channel.

The CS5351 uses a 5th-order, multi-bit delta-sigma modulator followed by digital filtering and decimation, which removes the need for an external anti-alias filter.

The CS5351 is ideal for audio systems requiring wide dynamic range, negligible distortion and low noise, such as A/V receivers, DVD-R, CD-R, digital mixing consoles, and effects processors.

ORDERING INFORMATION

CS5351-KS	-10° to 70° C	24-pin SOIC
CS5351-BS	-40° to 85° C	24-pin SOIC
CS5351-KZ	-10° to 70° C	24-pin TSSOP
CS5351-BZ	-40° to 85° C	24-pin TSSOP
CDB5351		Evaluation Board

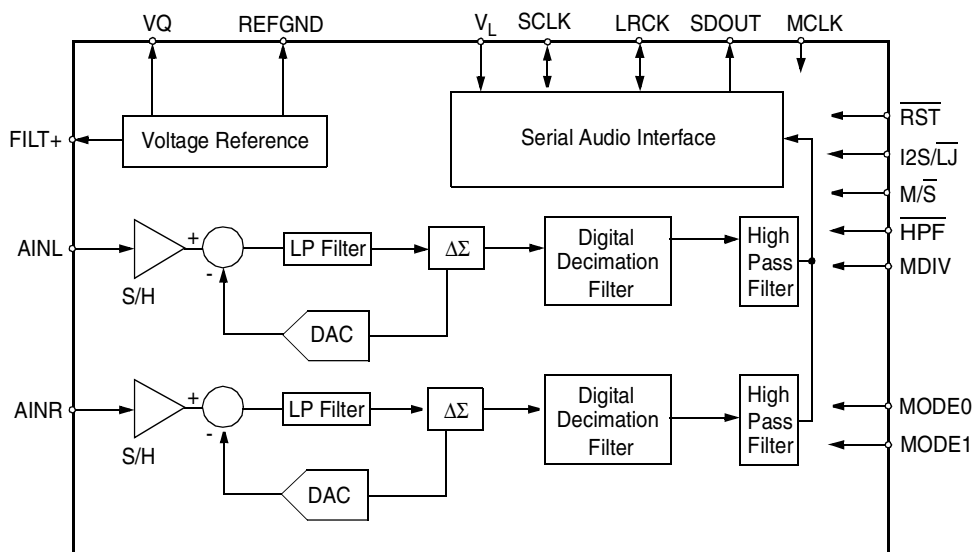

Preliminary Product Information

This document contains information for a new product. Cirrus Logic reserves the right to modify this product without notice.

TABLE OF CONTENTS

1 PIN DESCRIPTIONS	4
2 TYPICAL CONNECTION DIAGRAM	5
3 APPLICATIONS	6
3.1 Operational Mode/Sample Rate Range Select	6
3.2 System Clocking	6
3.2.1 Master Mode	7
3.2.2 Slave Mode	8
3.3 Power-up Sequence	8
3.4 Analog Connections	8
3.5 High Pass Filter and DC Offset Calibration	9
3.6 Overflow Detection	9
3.6.1 OVFL Output Timing	10
3.7 Grounding and Power Supply Decoupling	10
3.8 Synchronization of Multiple Devices	10
4 CHARACTERISTICS AND SPECIFICATIONS	11
ANALOG CHARACTERISTICS (CS5351-KS/KZ)	11
ANALOG CHARACTERISTICS (CS5351-BS/BZ)	12
DIGITAL DECIMATION FILTER CHARACTERISTICS	13
DC ELECTRICAL CHARACTERISTICS	16
DIGITAL CHARACTERISTICS	16
THERMAL CHARACTERISTICS	16
ABSOLUTE MAXIMUM RATINGS	17
SWITCHING CHARACTERISTICS - SERIAL AUDIO PORT	18
5 PARAMETER DEFINITIONS	21
6 PACKAGE DIMENSIONS	22
7 ADDENDUM	24

LIST OF FIGURES

Figure 1. Typical Connection Diagram	5
Figure 2. CS5351 Master Mode Clocking	7
Figure 3. CS5351 Recommended Analog Input Buffer	9

Contacting Cirrus Logic Support

For all product questions and inquiries contact a Cirrus Logic Sales Representative.
 To find one nearest you go to <http://www.cirrus.com/corporate/contacts/sales.cfm>

IMPORTANT NOTICE

"Preliminary" product information describes products that are in production, but for which full characterization data is not yet available. "Advance" product information describes products that are in development and subject to development changes. Cirrus Logic, Inc. and its subsidiaries ("Cirrus") believe that the information contained in this document is accurate and reliable. However, the information is subject to change without notice and is provided "AS IS" without warranty of any kind (express or implied). Customers are advised to obtain the latest version of relevant information to verify, before placing orders, that information being relied on is current and complete. All products are sold subject to the terms and conditions of sale supplied at the time of order acknowledgment, including those pertaining to warranty, patent infringement, and limitation of liability. No responsibility is assumed by Cirrus for the use of this information, including use of this information as the basis for manufacture or sale of any items, or for infringement of patents or other rights of third parties. This document is the property of Cirrus and by furnishing this information, Cirrus grants no license, express or implied under any patents, mask work rights, copyrights, trademarks, trade secrets or other intellectual property rights. Cirrus owns the copyrights of the information contained herein and gives consent for copies to be made of the information only for use within your organization with respect to Cirrus integrated circuits or other parts of Cirrus. This consent does not extend to other copying such as copying for general distribution, advertising or promotional purposes, or for creating any work for resale.

An export permit needs to be obtained from the competent authorities of the Japanese Government if any of the products or technologies described in this material and controlled under the "Foreign Exchange and Foreign Trade Law" is to be exported or taken out of Japan. An export license and/or quota needs to be obtained from the competent authorities of the Chinese Government if any of the products or technologies described in this material is subject to the PRC Foreign Trade Law and is to be exported or taken out of the PRC.

CERTAIN APPLICATIONS USING SEMICONDUCTOR PRODUCTS MAY INVOLVE POTENTIAL RISKS OF DEATH, PERSONAL INJURY, OR SEVERE PROPERTY OR ENVIRONMENTAL DAMAGE ("CRITICAL APPLICATIONS"). CIRRUS PRODUCTS ARE NOT DESIGNED, AUTHORIZED, OR WARRANTED TO BE SUITABLE FOR USE IN LIFE-SUPPORT DEVICES OR SYSTEMS OR OTHER CRITICAL APPLICATIONS. INCLUSION OF CIRRUS PRODUCTS IN SUCH APPLICATIONS IS UNDERSTOOD TO BE FULLY AT THE CUSTOMER'S RISK.

Cirrus Logic, Cirrus, and the Cirrus Logic logo designs are trademarks of Cirrus Logic, Inc. All other brand and product names in this document may be trademarks or service marks of their respective owners.



Figure 4. Single Speed Mode Stopband Rejection 14

Figure 5. Single Speed Mode Transition Band 14

Figure 6. Single Speed Mode Transition Band (Detail)..... 14

Figure 7. Single Speed Mode Passband Ripple 14

Figure 8. Double Speed Mode Stopband Rejection 14

Figure 9. Double Speed Mode Transition Band 14

Figure 10. Double Speed Mode Transition Band (Detail) 15

Figure 11. Double Speed Mode Passband Ripple 15

Figure 12. Quad Speed Mode Stopband Rejection 15

Figure 13. Quad Speed Mode Transition Band..... 15

Figure 14. Quad Speed Mode Transition Band (Detail) 15

Figure 15. Quad Speed Mode Passband Ripple..... 15

Figure 16. Master Mode, Left Justified SAI 19

Figure 17. Slave Mode, Left Justified SAI 19

Figure 18. Master Mode, I²S SAI 19

Figure 19. Slave Mode, I²S SAI 19

Figure 20. OVFL Output Timing 19

Figure 21. Left-Justified Serial Audio Interface 20

Figure 22. I²S Serial Audio Interface..... 20

Figure 23. OVFL Output Timing, I2S Format 20

Figure 24. OVFL Output Timing, Left-Justified Format 20

Figure 25. CS5351/CS5361 Analog Input Buffer 24

LIST OF TABLES

Table 1. CS5351 Mode Control 6

Table 2. CS5351 Common Master Clock Frequencies 7

Table 3. CS5351 Slave Mode Clock Ratios 8

1 PIN DESCRIPTIONS

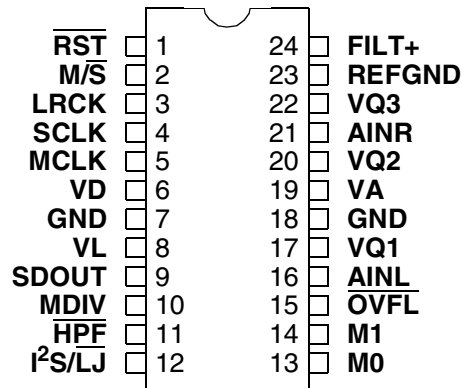

Pin Name	#	Pin Description
RST	1	Reset (<i>Input</i>) - The device enters a low power mode when low.
M/S	2	Master/Slave Mode (<i>Input</i>) - Selects operation as either clock master or slave.
LRCK	3	Left Right Clock (<i>Input/Output</i>) - Determines which channel, Left or Right, is currently active on the serial audio data line.
SCLK	4	Serial Clock (<i>Input/Output</i>) - Serial clock for the serial audio interface.
MCLK	5	Master Clock (<i>Input</i>) - Clock source for the delta-sigma modulator and digital filters.
VD	6	Digital Power (<i>Input</i>) - Positive power supply for the digital section.
GND	7, 18	Ground (<i>Input</i>) - Ground reference. Must be connected to analog ground.
VL	8	Logic Power (<i>Input</i>) - Positive power for the digital input/output.
SDOUT	9	Serial Audio Data Output (<i>Output</i>) - Output for two's complement serial audio data.
MDIV	10	MCLK Divider (<i>Input</i>) - Enables a master clock divide by two function.
HPF	11	High Pass Filter Enable (<i>Input</i>) - Enables the Digital High-Pass Filter.
I ² S/LJ	12	Serial Audio Interface Format Select (<i>Input</i>) - Selects either the left-justified or I ² S format for the SAI.
M0	13,	Mode Selection (<i>Input</i>) - Determines the operational mode of the device.
M1	14	
OVFL	15	Overflow (<i>Output, open drain</i>) - Detects an overflow condition on both left and right channels.
AINR	16,	Analog Input (<i>Input</i>) - The full scale analog input level is specified in the Analog Characteristics specification table.
AINL	21	
VQ1	17,	Quiescent Voltage (<i>Input/Output</i>) - Filter connection for the internal quiescent reference voltage.
VQ2	20,	
VQ3	22	
VA	19	Analog Power (<i>Input</i>) - Positive power supply for the analog section.
REF_GND	23	Reference Ground (<i>Input</i>) - Ground reference for the internal sampling circuits.
FILT+	24	Positive Voltage Reference (<i>Output</i>) - Positive reference voltage for the internal sampling circuits.

2 TYPICAL CONNECTION DIAGRAM

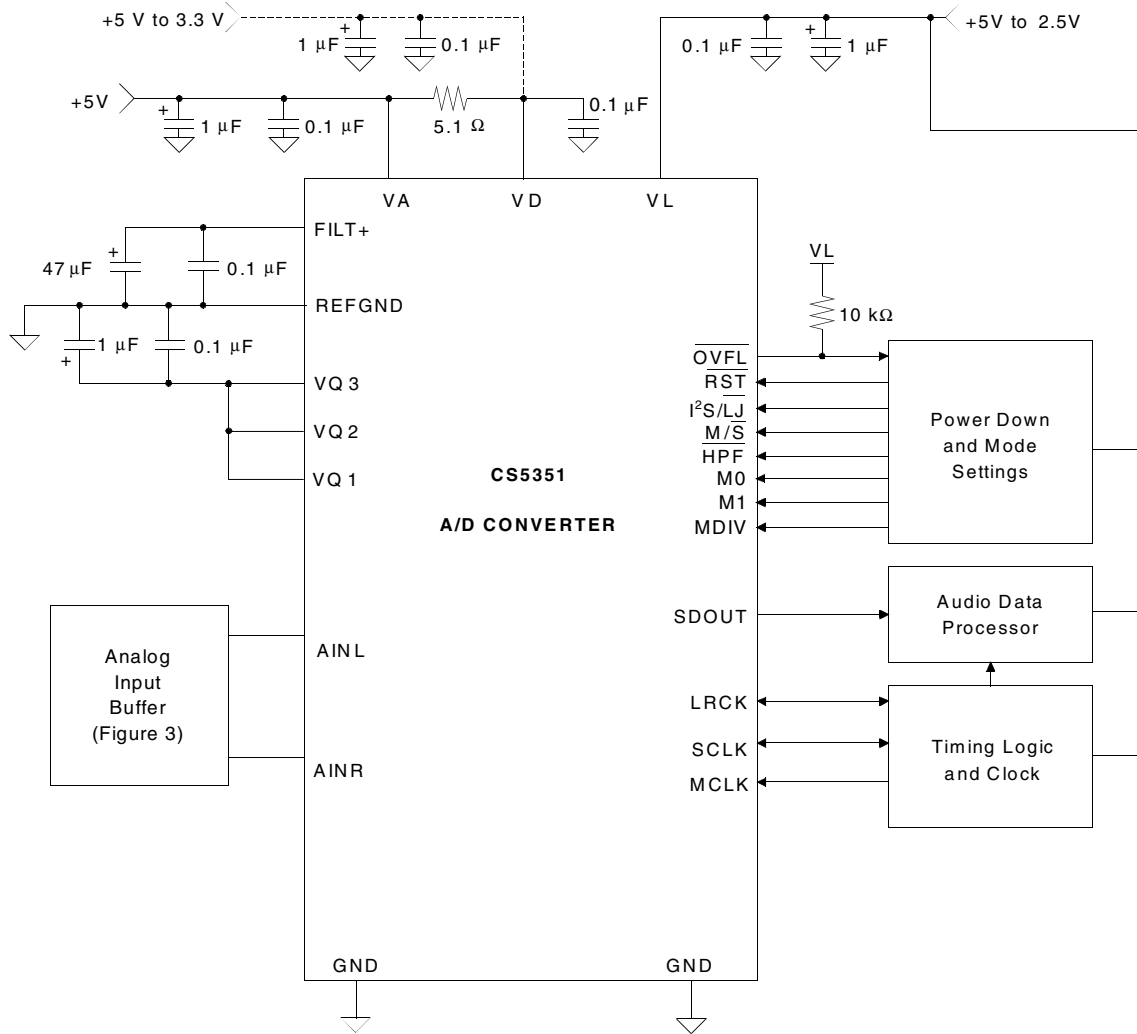

Figure 1. Typical Connection Diagram

3 APPLICATIONS

3.1 Operational Mode/Sample Rate Range Select

The output sample rate, F_s , can be adjusted from 2kHz to 192kHz. The CS5351 must be set to the proper speed mode via the mode pins, M1 and M0. Refer to Table 1.

M1 (Pin 14)	M0 (Pin 13)	MODE	Output Sample Rate (F_s)
0	0	Single Speed Mode	2kHz - 50kHz
0	1	Double Speed Mode	50kHz - 100kHz
1	0	Quad Speed Mode	100kHz - 192kHz
1	1	Reserved	

Table 1. CS5351 Mode Control

3.2 System Clocking

The device supports operation in either Master Mode, where the left/right and serial clocks are synchronously generated on-chip, or Slave Mode, which requires external generation of the left/right and serial clocks. The device also includes a master clock divider in Master Mode where the master clock will be internally divided prior to any other internal circuitry when MDIV is enabled, set to logic 1. In Slave Mode the MDIV pin needs to be disabled, set to logic 0.

3.2.1 Master Mode

In Master mode, LRCK and SCLK operate as outputs. The left/right and serial clocks are internally derived from the master clock with the left/right clock equal to F_s and the serial clock equal to $64 \times F_s$, as shown in Figure 2. Refer to Table 2 for common master clock frequencies

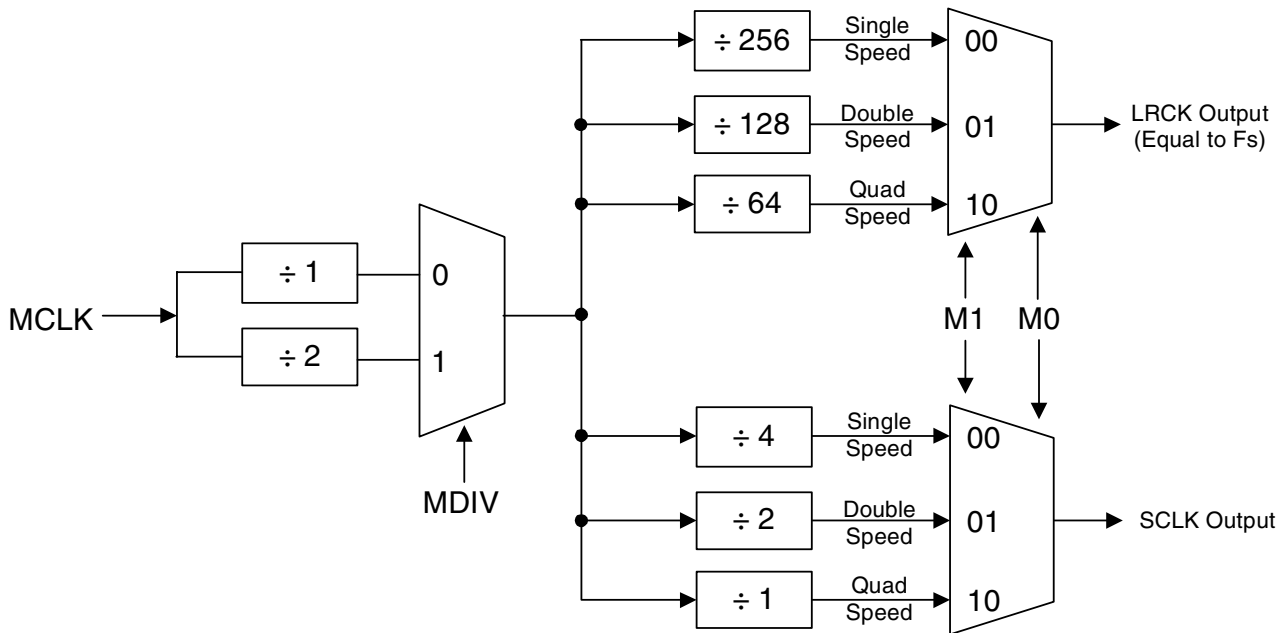

Figure 2. CS5351 Master Mode Clocking

SAMPLE RATE (kHz)	MDIV = 0 MCLK (MHz)	MDIV = 1 MCLK (MHz)
32	8.192	16.384
44.1	11.2896	22.5792
48	12.288	24.576
64	8.192	16.384
88.2	11.2896	22.5792
96	12.288	24.576
176.4	11.2896	22.5792
192	12.288	24.576

Table 2. CS5351 Common Master Clock Frequencies

3.2.2 Slave Mode

LRCK and SCLK operate as inputs in Slave mode. The left/right clock must be synchronously derived from the master clock and be equal to F_s . It is also recommended that the serial clock be synchronously derived from the master clock and be equal to $64x F_s$ to maximize system performance. Refer to Table 3 for required clock ratios.

	Single Speed Mode $F_s = 2\text{kHz to } 50\text{kHz}$	Double Speed Mode $F_s = 50\text{kHz to } 100\text{kHz}$	Quad Speed Mode $F_s = 100\text{kHz to } 192\text{kHz}$
MCLK/LRCK Ratio	256x (512x)*	128x (256x)*	128x (256x)*
SCLK/LRCK Ratio	32x, 64x, 128x	32x, 64x	64x

*Available when MDIV = 1 (for Master Mode)

Table 3. CS5351 Slave Mode Clock Ratios

3.3 Power-up Sequence

Reliable power-up can be accomplished by keeping the device in reset until the power supplies, clocks and configuration pins are stable. It is also recommended that reset be enabled if the analog or digital supplies drop below the minimum specified operating voltages to prevent power glitch related issues.

The internal reference voltage must be stable for the device to produce valid data. Therefore, there is a delay between the release of reset and the generation of valid output, due to the finite output impedance of FILT+ and the presence of the external capacitance.

3.4 Analog Connections

The analog modulator samples the input at 6.144 MHz (MCLK=12.288 MHz). The digital filter will reject signals within the stopband of the filter. However, there is no rejection for input signals which are $(n \times 6.144 \text{ MHz})$ the digital passband frequency, where $n=0,1,2,\dots$ Refer to Figure 3 which shows the suggested filter that will attenuate any noise energy at 6.144 MHz, in addition to providing the optimum source impedance for the modulators. The use of capacitors which have a large voltage coefficient (such as general purpose ceramics) must be avoided since these can degrade signal linearity.

Please see the Addendum at the end of the datasheet for an analog input buffer that can be used with both the CS5351 as well as the CS5361 with a simple change in the bill of materials.

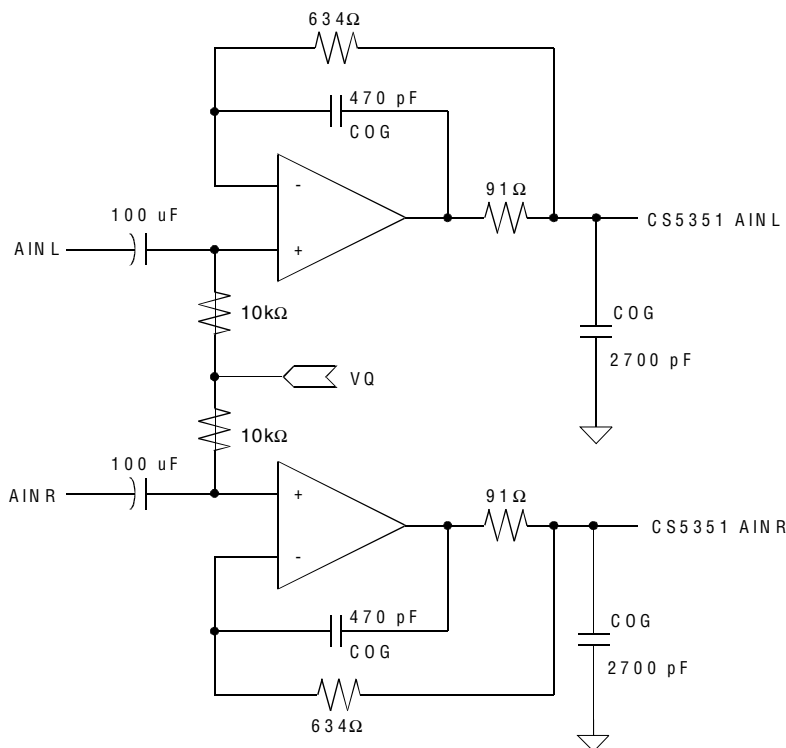

Figure 3. CS5351 Recommended Analog Input Buffer

3.5 High Pass Filter and DC Offset Calibration

The operational amplifiers in the input circuitry driving the CS5351 may generate a small DC offset into the A/D converter. The CS5351 includes a high pass filter after the decimator to remove any DC offset which could result in recording a DC level, possibly yielding "clicks" when switching between devices in a multichannel system.

The high pass filter continuously subtracts a measure of the DC offset from the output of the decimation filter. If the $\overline{\text{HPF}}$ pin is taken high during normal operation, the current value of the DC offset register is frozen and this DC offset will continue to be subtracted from the conversion result. This feature makes it possible to perform a system DC offset calibration by:

- 1) Running the CS5351 with the high pass filter enabled until the filter settles. See the Digital Filter Characteristics for filter settling time.
- 2) Disabling the high pass filter and freezing the stored DC offset.

A system calibration performed in this way will eliminate offsets anywhere in the signal path between the calibration point and the CS5351.

3.6 Overflow Detection

The CS5361 includes overflow detection on both the left and right channels. This time multiplexed information is presented as open drain, active low on pin 15, $\overline{\text{OVFL}}$. The $\overline{\text{OVFL}}_L$ and $\overline{\text{OVFL}}_R$ data will go to a logical low as soon as an overrange condition in either channel is detected. The data will remain low

as specified in the Switching Characteristics - Serial Audio Port section. This ensures sufficient time to detect an overrange condition regardless of the speed mode. After the timeout, the OVFL_L and OVFL_R data will return to a logical high if there has not been any other overrange condition detected. Please note that an overrange condition on either channel will restart the timeout period for both channels.

3.6.1 $\overline{\text{OVFL}}$ Output Timing

In left-justified format, the $\overline{\text{OVFL}}$ pin is updated one SCLK period after an LRCK transition. In I^2S format, the $\overline{\text{OVFL}}$ pin is updated two SCLK periods after an LRCK transition. Refer to Figures 23 and 24. In both cases the $\overline{\text{OVFL}}$ data can be easily demultiplexed by using the LRCK to latch the data. In left-justified format, the rising edge of LRCK would latch the right channel overflow status, and the falling edge of LRCK would latch the left channel overflow status. In I^2S format, the falling edge of LRCK would latch the right channel overflow status and the rising edge of LRCK would latch the left channel overflow status.

3.7 Grounding and Power Supply Decoupling

As with any high resolution converter, the CS5351 requires careful attention to power supply and grounding arrangements if its potential performance is to be realized. Figure 1 shows the recommended power arrangements, with VA and VL connected to clean supplies. VD, which powers the digital filter, may be run from the system logic supply or may be powered from the analog supply via a resistor. In this case, no additional devices should be powered from VD. Decoupling capacitors should be as near to the ADC as possible, with the low value ceramic capacitor being the nearest. All signals, especially clocks, should be kept away from the FILT+ and VQ pins in order to avoid unwanted coupling into the modulators. The FILT+ and VQ decoupling capacitors, particularly the 0.1 μF , must be positioned to minimize the electrical path from FILT+ and REFGND. The CDB5351 evaluation board demonstrates the optimum layout and power supply arrangements. To minimize digital noise, connect the ADC digital outputs only to CMOS inputs.

3.8 Synchronization of Multiple Devices

In systems where multiple ADCs are required, care must be taken to achieve simultaneous sampling. To ensure synchronous sampling, the MCLK and LRCK must be the same for all of the CS5351's in the system. If only one master clock source is needed, one solution is to place one CS5351 in Master mode, and slave all of the other CS5351's to the one master. If multiple master clock sources are needed, a possible solution would be to supply all clocks from the same external source and time the CS5351 reset with the inactive edge of MCLK. This will ensure that all converters begin sampling on the same clock edge.

4 CHARACTERISTICS AND SPECIFICATIONS

ANALOG CHARACTERISTICS (CS5351-KS/KZ) (Test conditions (unless otherwise specified): Input test signal is a 1 kHz sine wave; measurement bandwidth is 10 Hz to 20 kHz. Typical performance characteristics are derived from measurements taken at $T_A = 25^\circ\text{C}$, $V_L = V_D = 3.3\text{V}$ and $V_A = 5.0\text{V}$. Min/Max performance characteristics are guaranteed over the specified operating temperature and voltages.)

Parameter	Symbol	Min	Typ	Max	Unit
Single Speed Mode Fs = 48kHz					
Dynamic Range	A-weighted	102	108	-	dB
	unweighted	99	105	-	dB
Total Harmonic Distortion + Noise (Note 1)	THD+N	-	-98	-92	dB
	-1 dB	-	-85	-	dB
	-20 dB	-	-45	-	dB
	-60 dB	-	-	-	dB
Double Speed Mode Fs = 96kHz					
Dynamic Range	A-weighted	102	108	-	dB
	unweighted	99	105	-	dB
	40kHz bandwidth unweighted	-	102	-	dB
Total Harmonic Distortion + Noise (Note 1)	THD+N	-	-98	-92	dB
	-1 dB	-	-85	-	dB
	-20 dB	-	-45	-	dB
	-60 dB	-	-	-	dB
	40kHz bandwidth -1dB	-	-95	-	dB
Quad Speed Mode Fs = 192kHz					
Dynamic Range	A-weighted	102	108	-	dB
	unweighted	99	105	-	dB
	40kHz bandwidth unweighted	-	102	-	dB
Total Harmonic Distortion + Noise (Note 1)	THD+N	-	-98	-92	dB
	-1 dB	-	-85	-	dB
	-20 dB	-	-45	-	dB
	-60 dB	-	-	-	dB
	40kHz bandwidth -1dB	-	-95	-	dB
Dynamic Performance for All Modes					
Interchannel Isolation		-	95	-	dB
Interchannel Phase Deviation		-	0.0001	-	Degree
DC Accuracy					
Interchannel Gain Mismatch		-	0.1	-	dB
Gain Error			-	±5	%
Gain Drift		-	±100	-	ppm/°C
Offset Error	HPF enabled	-	0	-	LSB
	HPF disabled	-	100	-	LSB
Analog Input Characteristics					
Full-scale Input Voltage		0.95	1.0	1.05	Vrms
Input Impedance		18	-	-	kΩ

Note: 1. Referred to the typical full-scale input voltage

ANALOG CHARACTERISTICS (CS5351-BS/BZ) (Test conditions (unless otherwise specified): Input test signal is a 1 kHz sine wave; measurement bandwidth is 10 Hz to 20 kHz. Typical performance characteristics are derived from measurements taken at $T_A = 25^\circ\text{C}$, $V_L = V_D = 3.3\text{V}$ and $V_A = 5.0\text{V}$. Min/Max performance characteristics are guaranteed over the specified operating temperature and voltages.)

Parameter	Symbol	Min	Typ	Max	Unit
Single Speed Mode $F_s = 48\text{kHz}$					
Dynamic Range	A-weighted	101	108	-	dB
	unweighted	98	105	-	dB
Total Harmonic Distortion + Noise (Note 1)	-1 dB	-	-98	-91	dB
	-20 dB	-	-85	-	dB
	-60 dB	-	-45	-	dB
	40kHz bandwidth	-	-95	-	dB
Double Speed Mode $F_s = 96\text{kHz}$					
Dynamic Range	A-weighted	101	108	-	dB
	unweighted	98	105	-	dB
	40kHz bandwidth unweighted	-	102	-	dB
Total Harmonic Distortion + Noise (Note 1)	-1 dB	-	-98	-91	dB
	-20 dB	-	-85	-	dB
	-60 dB	-	-45	-	dB
	40kHz bandwidth	-	-95	-	dB
Quad Speed Mode $F_s = 192\text{kHz}$					
Dynamic Range	A-weighted	101	108	-	dB
	unweighted	98	105	-	dB
	40kHz bandwidth unweighted	-	102	-	dB
Total Harmonic Distortion + Noise (Note 1)	-1 dB	-	-98	-91	dB
	-20 dB	-	-85	-	dB
	-60 dB	-	-45	-	dB
	40kHz bandwidth	-	-95	-	dB
Dynamic Performance for All Modes					
Interchannel Isolation		-	95	-	dB
Interchannel Phase Deviation		-	0.0001	-	Degree
DC Accuracy					
Interchannel Gain Mismatch		-	0.1	-	dB
Gain Error			-	± 5	%
Gain Drift		-	± 100	-	ppm/ $^\circ\text{C}$
Offset Error	HPF enabled	-	0	-	LSB
	HPF disabled	-	100	-	LSB
Analog Input Characteristics					
Full-scale Input Voltage		0.9	1.0	1.1	V _{rms}
Input Impedance		18	-	-	k Ω

DIGITAL DECIMATION FILTER CHARACTERISTICS

Parameter	Symbol	Min	Typ	Max	Unit
Single Speed Mode (2kHz to 50kHz sample rates)					
Passband (-0.1 dB) (Note 3)		0	-	0.47	Fs
Passband Ripple		-	-	±0.035	dB
Stopband (Note 3)		0.58	-	-	Fs
Stopband Attenuation		-95	-	-	dB
Total Group Delay (Fs = Output Sample Rate)	t_{gd}	-	12/Fs	-	s
Group Delay Variation vs. Frequency	Δt_{gd}	-	-	0.0	μs
Double Speed Mode (50kHz to 100kHz sample rates)					
Passband (-0.1 dB) (Note 3)		0	-	0.45	Fs
Passband Ripple		-	-	±0.035	dB
Stopband (Note 3)		0.68	-	-	Fs
Stopband Attenuation		-92	-	-	dB
Total Group Delay (Fs = Output Sample Rate)	t_{gd}	-	9/Fs	-	s
Group Delay Variation vs. Frequency	Δt_{gd}	-	-	0.0	μs
Quad Speed Mode (100kHz to 192kHz sample rates)					
Passband (-0.1 dB) (Note 3)		0	-	0.24	Fs
Passband Ripple		-	-	±0.035	dB
Stopband (Note 3)		0.78	-	-	Fs
Stopband Attenuation		-97	-	-	dB
Total Group Delay (Fs = Output Sample Rate)	t_{gd}	-	5/Fs	-	s
Group Delay Variation vs. Frequency	Δt_{gd}	-	-	0.0	μs
High Pass Filter Characteristics					
Frequency Response -3.0 dB		-	1	-	Hz
-0.13 dB (Note 2)			20	-	Hz
Phase Deviation @ 20Hz (Note 2)		-	10	-	Deg
Passband Ripple		-	-	0	dB
Filter Settling Time			$10^5/Fs$		s

Notes: 2. Response shown is for Fs equal to 48 kHz. Filter characteristics scale with Fs.

3. The filter frequency response scales precisely with Fs.

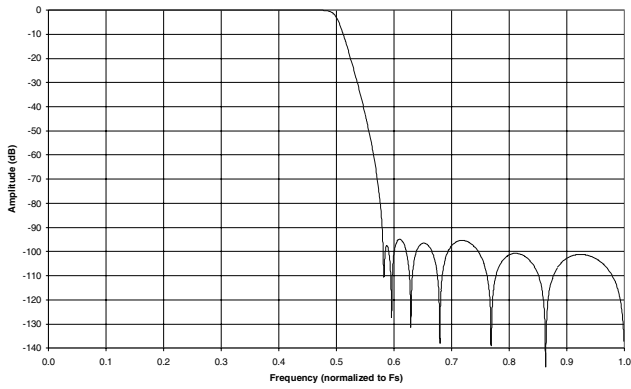

Figure 4. Single Speed Mode Stopband Rejection

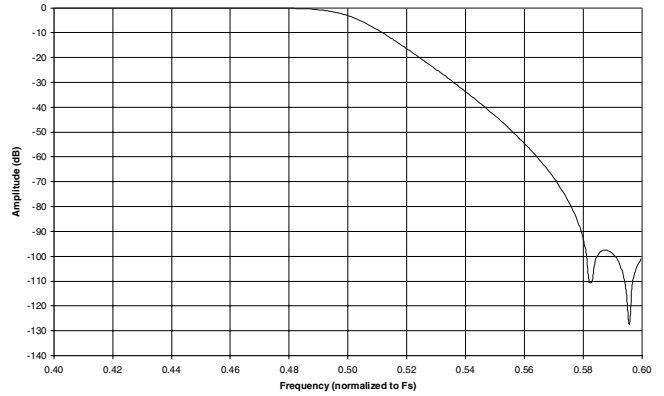

Figure 5. Single Speed Mode Transition Band

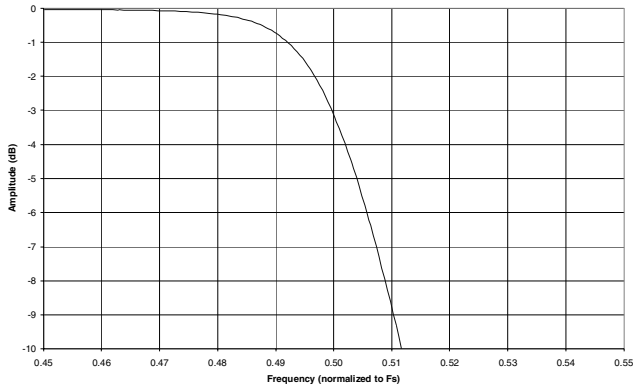

Figure 6. Single Speed Mode Transition Band (Detail)

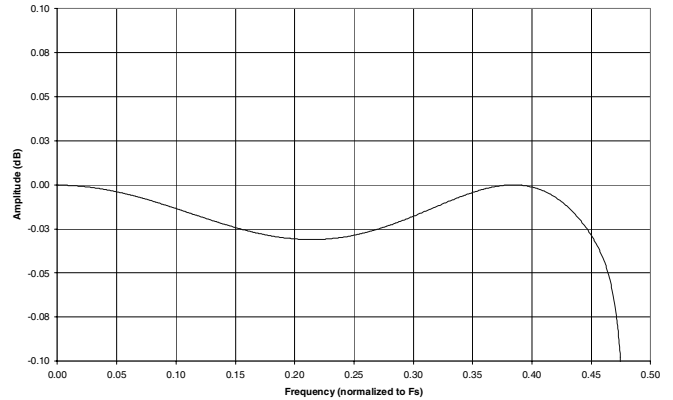

Figure 7. Single Speed Mode Passband Ripple

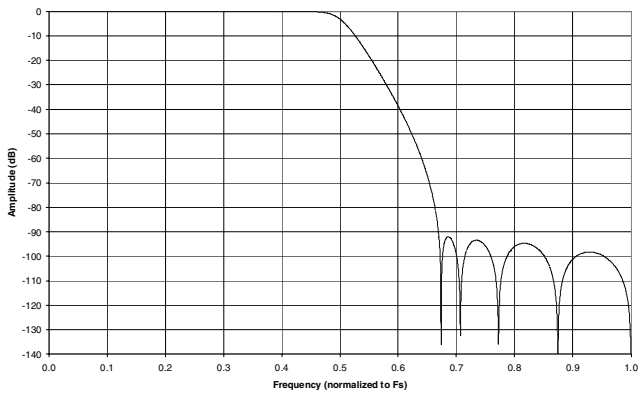

Figure 8. Double Speed Mode Stopband Rejection

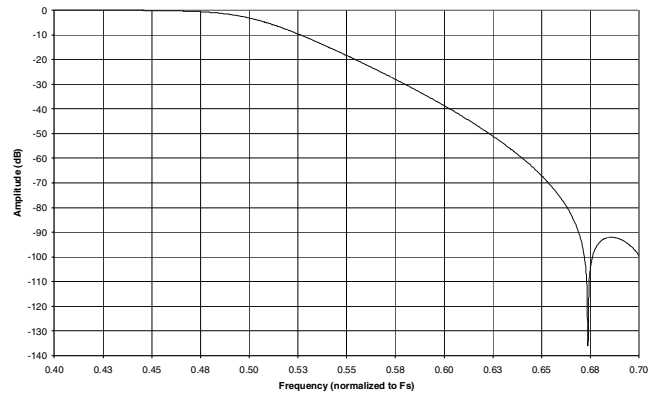

Figure 9. Double Speed Mode Transition Band

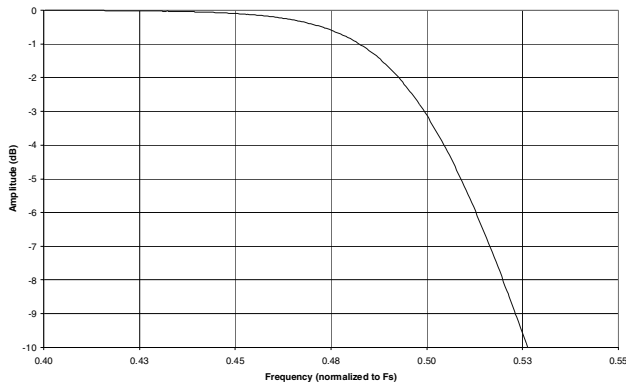

Figure 10. Double Speed Mode Transition Band (Detail)

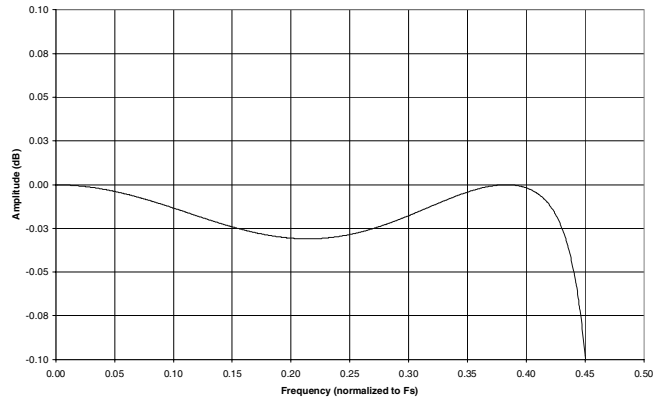

Figure 11. Double Speed Mode Passband Ripple

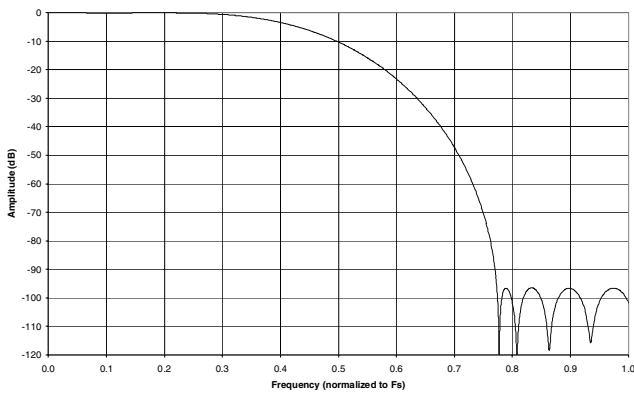

Figure 12. Quad Speed Mode Stopband Rejection

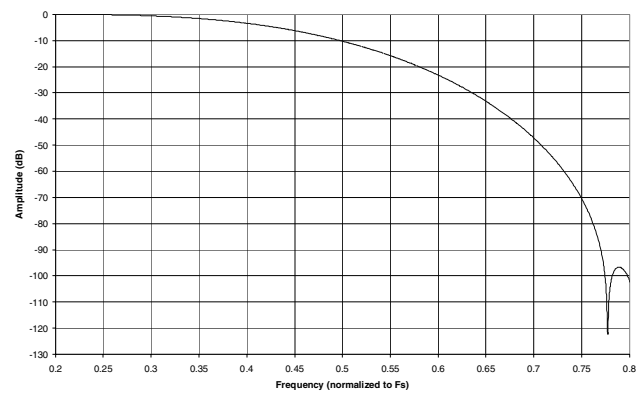

Figure 13. Quad Speed Mode Transition Band

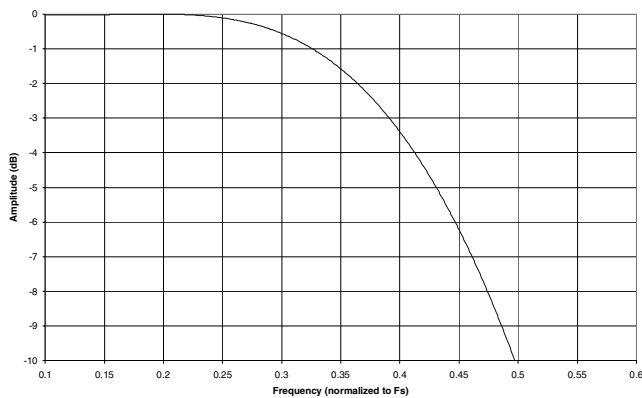

Figure 14. Quad Speed Mode Transition Band (Detail)

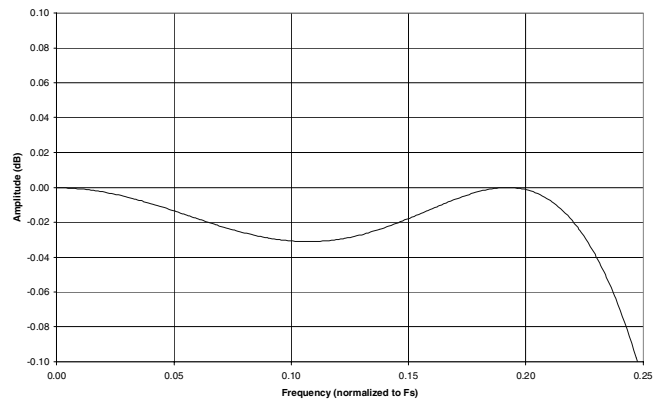

Figure 15. Quad Speed Mode Passband Ripple

DC ELECTRICAL CHARACTERISTICS (GND = 0V, all voltages with respect to ground.
MCLK=12.288 MHz; Master Mode)

Parameter	Symbol	Min	Typ	Max	Unit
DC Power Supplies:					
Positive Analog	VA	4.75	5.0	5.25	V
Positive Digital	VD	3.1	-	5.25	V
Positive Logic	VL	2.37	-	5.25	V
Power Supply Current (Normal Operation)	VA	IA	17.5	21	mA
	VL, VD = 5 V	ID	22	26	mA
	VL, VD = 3.3V	ID	14.5	17	mA
Power Supply Current (Power-Down Mode)(Note 4)	VA	IA	2	-	mA
	VL, VD=5V	ID	2	-	mA
Power Consumption (Normal Operation)					
	VL, VD=5V	-	198	235	mW
	VL, VD = 3.3V	-	135	161	mW
	(Power-Down Mode)	-	20	-	mW
Power Supply Rejection Ratio (1 kHz) (Note 5)	PSRR	-	65	-	dB
V _Q Nominal Voltage		-	2.5	-	V
Output Impedance		-	25	-	kΩ
Maximum allowable DC current source/sink		-	0.01	-	mA
Filt+ Nominal Voltage		-	5	-	V
Output Impedance		-	35	-	kΩ
Maximum allowable DC current source/sink		-	0.01	-	mA

Notes: 4. Power Down Mode is defined as \overline{RST} = Low with all clocks and data lines held static.

5. Valid with the recommended capacitor values on Filt+ and V_Q as shown in the Typical Connection Diagram.

DIGITAL CHARACTERISTICS

Parameter	Symbol	Min	Typ	Max	Units
High-Level Input Voltage (% of VL)	V _{IH}	70%	-	-	V
Low-Level Input Voltage (% of VL)	V _{IL}	-	-	30%	V
High-Level Output Voltage at I _o = 100 uA (% of VL)	V _{OH}	70%	-	-	V
Low-Level Output Voltage at I _o =100 uA (% of VL)	V _{OL}	-	-	15%	V
OVFL Current Sink	I _{ovfl}	-	-	4.0	mA
Input Leakage Current	I _{in}	-	-	±10	μA

THERMAL CHARACTERISTICS

Parameter	Symbol	Min	Typ	Max	Unit	
Allowable Junction Temperature		-	-	135	°C	
Junction to Ambient Thermal Impedance	θ _{JA}	-	70	-	°C/W	
Ambient Operating Temperature (Power Applied)						
	-KS/KZ	T _A	-10	-	+70	°C
	-BS/BZ	T _A	-40	-	+85	°C

ABSOLUTE MAXIMUM RATINGS (GND = 0V, All voltages with respect to ground.) (Note 8)

Parameter		Symbol	Min	Typ	Max	Units
DC Power Supplies:	Analog	VA	-0.3	-	+6.0	V
	Logic	VL	-0.3	-	+6.0	V
	Digital	VD	-0.3	-	+6.0	V
Input Current	(Note 6)	I _{in}	-	-	±10	mA
Analog Input Voltage	(Note 7)	V _{IN}	GND-0.7	-	VA+0.7	V
Digital Input Voltage	(Note 7)	V _{IND}	-0.7	-	VL+0.7	V
Ambient Operating Temperature (Power Applied)		T _A	-50	-	+95	°C
Storage Temperature		T _{stg}	-65	-	+150	°C

- Notes:
6. Any pin except supplies. Transient currents of up to ±100 mA on the analog input pins will not cause SRC latch-up.
 7. The maximum over/under voltage is limited by the input current.
 8. Operation beyond these limits may result in permanent damage to the device. Normal operation is not guaranteed at these extremes.

SWITCHING CHARACTERISTICS - SERIAL AUDIO PORT (Logic "0" = GND = 0 V;
 Logic "1" = VL = 2.37V to 5.25V, VA = 5V±5%, VD = 3.1V to 5.25V, CL = 20 pF)

Parameter	Symbol	Min	Typ	Max	Unit	
Input Sample Rate	Single Speed Mode	Fs	2	-	50	kHz
	Double Speed Mode	Fs	50	-	100	kHz
	Quad Speed Mode	Fs	100	-	192	kHz
OVFL to LRCK edge setup time	t _{setup}	16/f _{sclk}	-	-	s	
OVFL to LRCK edge hold time	t _{hold}	1/f _{sclk}	-	-	s	
OVFL time-out on overrange condition	Fs = 44.1, 88.2, 176.4kHz	-	740	-	ms	
	Fs = 48, 96, 192kHz	-	680	-	ms	
MCLK Specifications						
MCLK Period	t _{clkw}	40	-	1953	ns	
MCLK Pulse Width High	t _{clkh}	15	-	-	ns	
MCLK Pulse Width Low	t _{ckl}	15	-	-	ns	
Master Mode						
SCLK falling to LRCK	t _{mslr}	-20	-	20	ns	
SCLK falling to SDOOUT valid	t _{sdo}	0	-	40	ns	
SCLK Duty Cycle		-	50	-	%	
SCLK Output Frequency		-	50	-	%	
Slave Mode						
Single Speed						
Output Sample Rate	Fs	2	-	50	kHz	
LRCK Duty Cycle		40	50	60	%	
SCLK Period	t _{sclkw}	163	-	-	ns	
SCLK High/Low	t _{sclkh}	20	-	-	ns	
SCLK falling to SDOOUT valid	t _{dss}	-	-	40	ns	
SCLK falling to LRCK edge	t _{slrd}	-20	-	20	ns	
Double Speed						
Output Sample Rate	Fs	50	-	100	kHz	
LRCK Duty Cycle		40	50	60	%	
SCLK Period	t _{sclkw}	163	-	-	ns	
SCLK High/Low	t _{sclkh}	20	-	-	ns	
SCLK falling to SDOOUT valid	t _{dss}	-	-	40	ns	
SCLK falling to LRCK edge	t _{slrd}	-20	-	20	ns	
Quad Speed						
Output Sample Rate	Fs	100	-	192	kHz	
LRCK Duty Cycle		40	50	60	%	
SCLK Period	t _{sclkw}	81	-	-	ns	
SCLK High/Low	t _{sclkh}	20	-	-	ns	
SCLK falling to SDOOUT valid	t _{dss}	-	-	20	ns	
SCLK falling to LRCK edge	t _{slrd}	-10	-	10	ns	

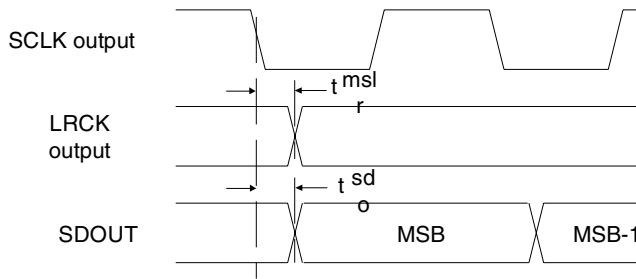

Figure 16. Master Mode, Left Justified SAI

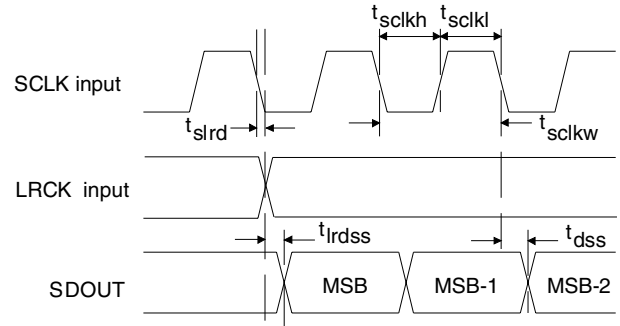

Figure 17. Slave Mode, Left Justified SAI

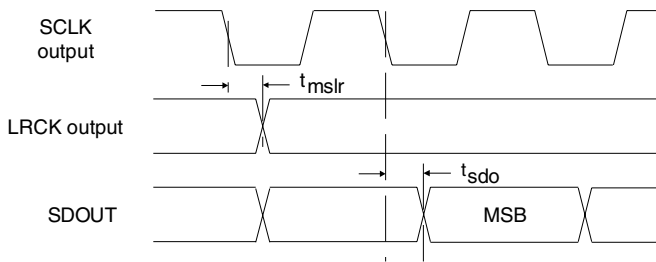

Figure 18. Master Mode, I²S SAI

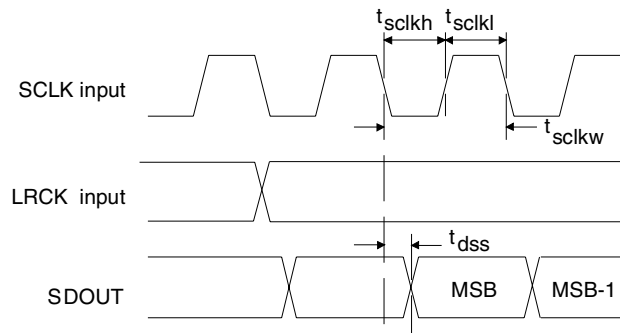

Figure 19. Slave Mode, I²S SAI

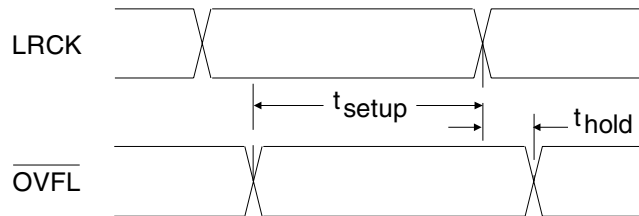

Figure 20. $\overline{\text{OVFL}}$ Output Timing

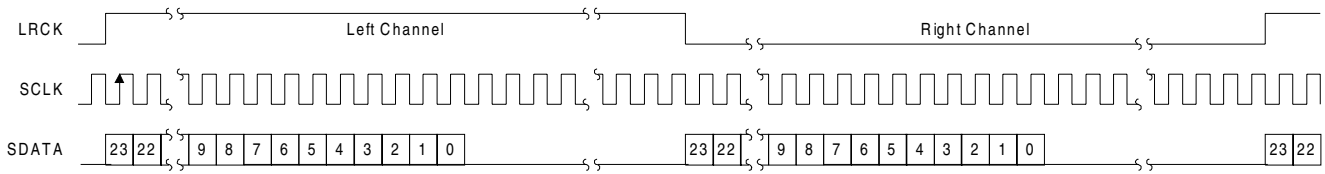

Figure 21. Left-Justified Serial Audio Interface

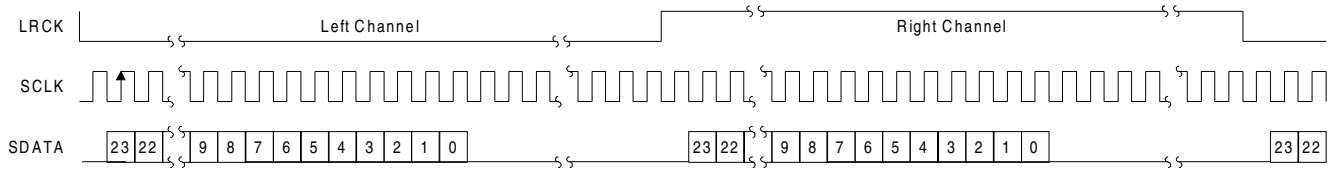

Figure 22. I²S Serial Audio Interface

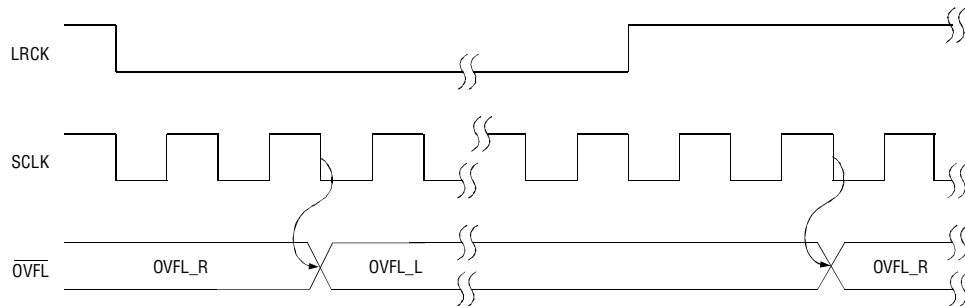

Figure 23. $\overline{\text{OVFL}}$ Output Timing, I²S Format

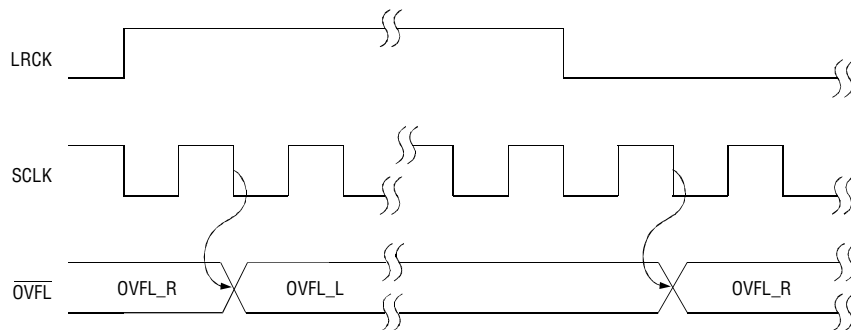

Figure 24. $\overline{\text{OVFL}}$ Output Timing, Left-Justified Format

5 PARAMETER DEFINITIONS

Dynamic Range

The ratio of the rms value of the signal to the rms sum of all other spectral components over the specified bandwidth. Dynamic Range is a signal-to-noise ratio measurement over the specified bandwidth made with a -60 dBFS signal. 60 dB is added to resulting measurement to refer the measurement to full-scale. This technique ensures that the distortion components are below the noise level and do not affect the measurement. This measurement technique has been accepted by the Audio Engineering Society, AES17-1991, and the Electronic Industries Association of Japan, EIAJ CP-307. Expressed in decibels.

Total Harmonic Distortion + Noise

The ratio of the rms value of the signal to the rms sum of all other spectral components over the specified bandwidth (typically 10 Hz to 20 kHz), including distortion components. Expressed in decibels. Measured at -1 and -20 dBFS as suggested in AES17-1991 Annex A.

Frequency Response

A measure of the amplitude response variation from 10 Hz to 20 kHz relative to the amplitude response at 1 kHz. Units in decibels.

Interchannel Isolation

A measure of crosstalk between the left and right channels. Measured for each channel at the converter's output with no signal to the input under test and a full-scale signal applied to the other channel. Units in decibels.

Interchannel Gain Mismatch

The gain difference between left and right channels. Units in decibels.

Gain Error

The deviation from the nominal full-scale analog output for a full-scale digital input.

Gain Drift

The change in gain value with temperature. Units in ppm/°C.

Offset Error

The deviation of the mid-scale transition (111...111 to 000...000) from the ideal. Units in mV.

6 PACKAGE DIMENSIONS

24L SOIC (300 MIL BODY) PACKAGE DRAWING

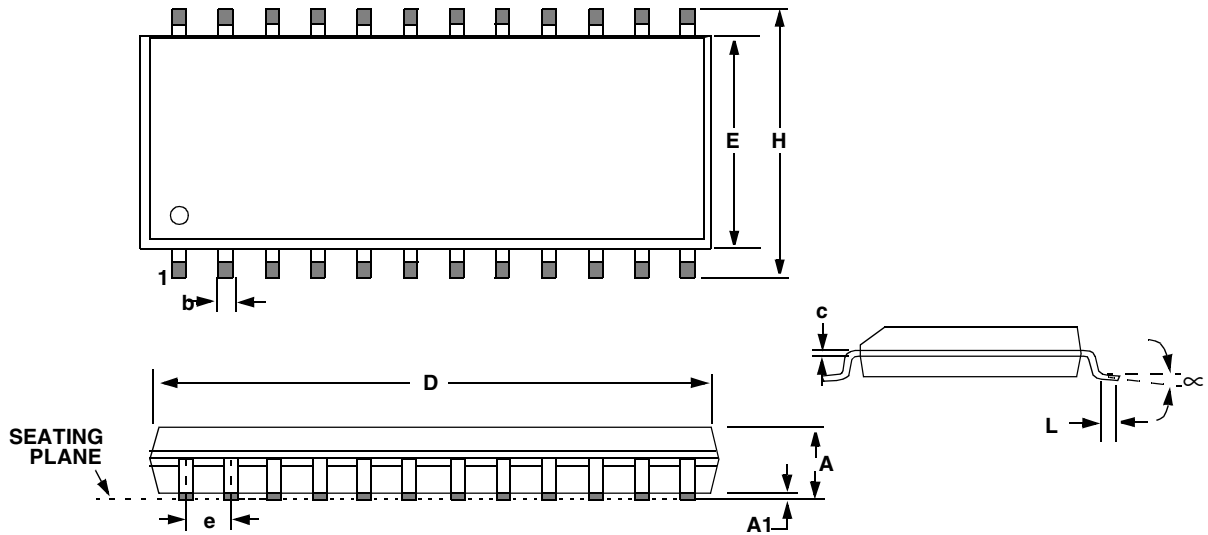

DIM	INCHES		MILLIMETERS	
	MIN	MAX	MIN	MAX
A	0.093	0.104	2.35	2.65
A1	0.004	0.012	0.10	0.30
B	0.013	0.020	0.33	0.51
C	0.009	0.013	0.23	0.32
D	0.598	0.614	15.20	15.60
E	0.291	0.299	7.40	7.60
e	0.040	0.060	1.02	1.52
H	0.394	0.419	10.00	10.65
L	0.016	0.050	0.40	1.27
∞	0°	8°	0°	8°



24L TSSOP (4.4 mm BODY) PACKAGE DRAWING

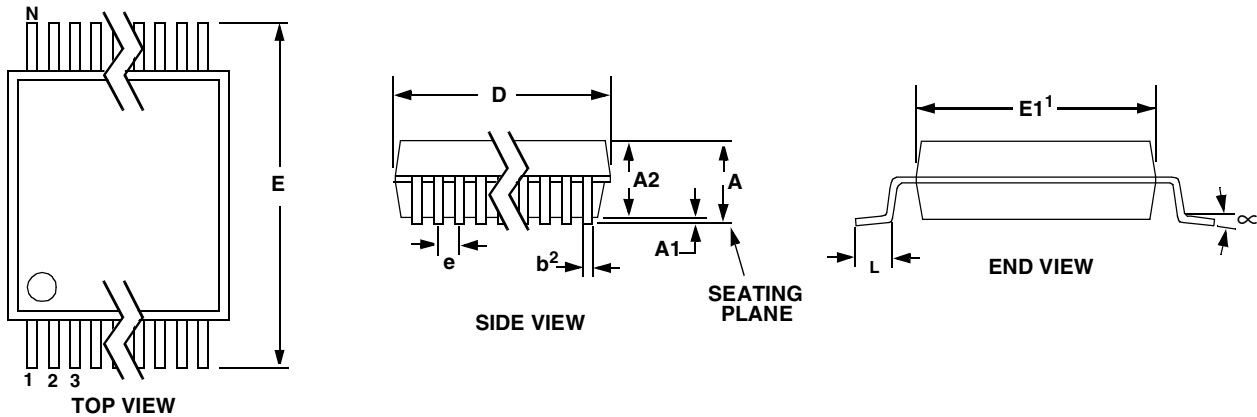

DIM	INCHES			MILLIMETERS			NOTE
	MIN	NOM	MAX	MIN	NOM	MAX	
A	--	--	0.043	--	--	1.10	
A1	0.002	0.004	0.006	0.05	--	0.15	
A2	0.03346	0.0354	0.037	0.85	0.90	0.95	
b	0.00748	0.0096	0.012	0.19	0.245	0.30	2,3
D	0.303	0.307	0.311	7.70	7.80	7.90	1
E	0.248	0.2519	0.256	6.30	6.40	6.50	
E1	0.169	0.1732	0.177	4.30	4.40	4.50	1
e	--	0.026 BSC	--	--	0.65 BSC	--	
L	0.020	0.024	0.028	0.50	0.60	0.70	
∞	0°	4°	8°	0°	4°	8°	

JEDEC #: MO-153

Controlling Dimension is Millimeters.

- Notes:
1. "D" and "E1" are reference datums and do not include mold flash or protrusions, but do include mold mismatch and are measured at the parting line, mold flash or protrusions shall not exceed 0.20 mm per side.
 2. Dimension "b" does not include dambar protrusion/intrusion. Allowable dambar protrusion shall be 0.13 mm total in excess of "b" dimension at maximum material condition. Dambar intrusion shall not reduce dimension "b" by more than 0.07 mm at least material condition.
 3. These dimensions apply to the flat section of the lead between 0.10 and 0.25 mm from lead tips.

7 ADDENDUM

The CS5351 and CS5361 family of analog-to-digital converters are functionally compatible and can easily be interchanged with minimal modifications to the input buffer circuitry.

Figure 25 shows an analog input buffer that provides anti-alias filtering, proper dc biasing, and optimum source impedance for the modulators. The input buffer shown will work well with both the CS5351 and the CS5361, merely by changing the bill of materials.

In order to use this buffer design with the CS5351, one would stuff the 0ohm resistors R19 and R22 and not populate R3 and R20. This will create a single-ended input buffer (as shown in Figure 3) with the unused differential input pin connected to the quiescent voltage of the converter (VQ). Note that in this configuration, it is unnecessary to have the second op-amp and related components.

In order to use this buffer design with the CS5361, one would stuff the 0ohm resistors R3 and R20 and not populate R19 and R22. This will create a fully differential analog input buffer.

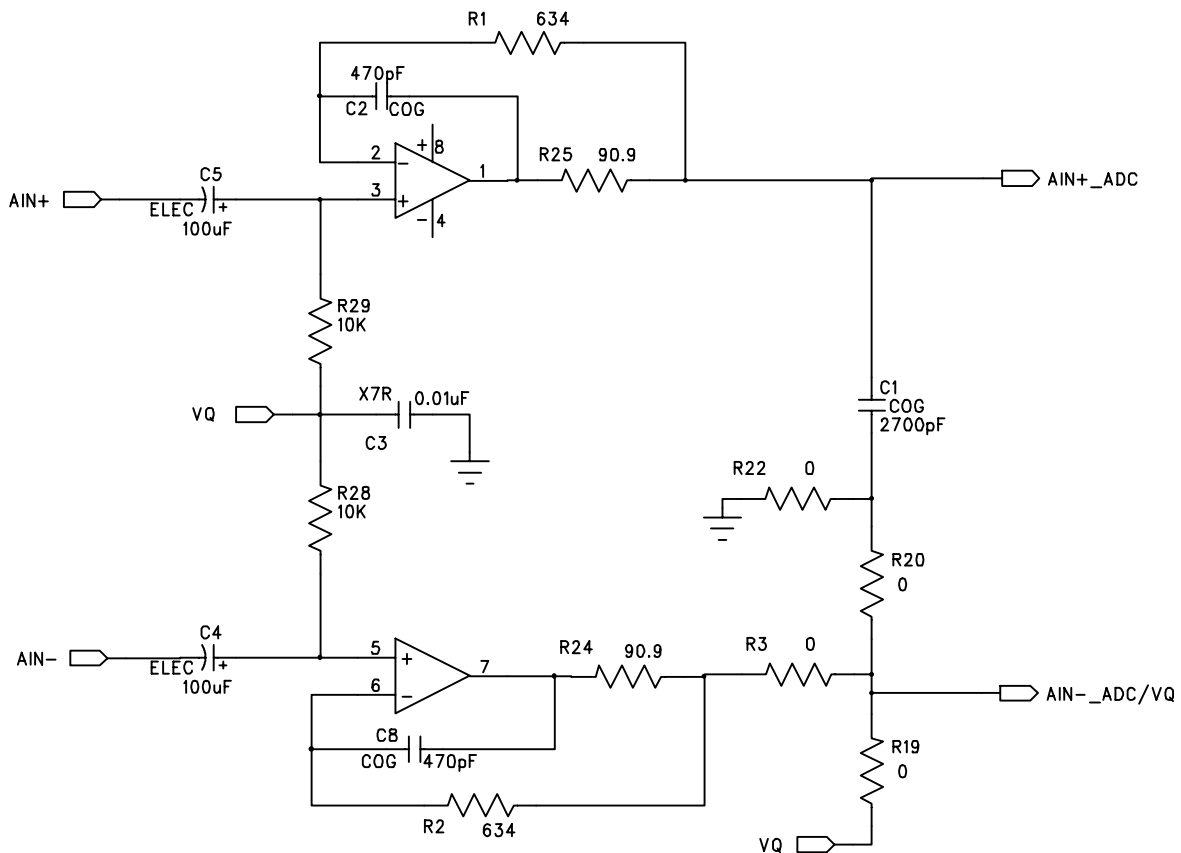

Figure 25. CS5351/CS5361 Analog Input Buffer