

# Current Mode PWM Controller

## FEATURES

- Automatic Feed Forward Compensation
- Programmable Pulse-by-Pulse Current Limiting
- Automatic Symmetry Correction in Push-pull Configuration
- Enhanced Load Response Characteristics
- Parallel Operation Capability for Modular Power Systems
- Differential Current Sense Amplifier with Wide Common Mode Range
- Double Pulse Suppression
- 500mA (Peak) Totem-pole Outputs
- $\pm 1\%$  Bandgap Reference
- Under-voltage Lockout
- Soft Start Capability
- Shutdown Terminal
- 500kHz Operation

## DESCRIPTION

The UC1846/7 family of control ICs provides all of the necessary features to implement fixed frequency, current mode control schemes while maintaining a minimum external parts count. The superior performance of this technique can be measured in improved line regulation, enhanced load response characteristics, and a simpler, easier-to-design control loop. Topological advantages include inherent pulse-by-pulse current limiting capability, automatic symmetry correction for push-pull converters, and the ability to parallel "power modules" while maintaining equal current sharing.

Protection circuitry includes built-in under-voltage lockout and programmable current limit in addition to soft start capability. A shutdown function is also available which can initiate either a complete shutdown with automatic restart or latch the supply off.

Other features include fully latched operation, double pulse suppression, deadline adjust capability, and a  $\pm 1\%$  trimmed bandgap reference.

The UC1846 features low outputs in the OFF state, while the UC1847 features high outputs in the OFF state.

## BLOCK DIAGRAM

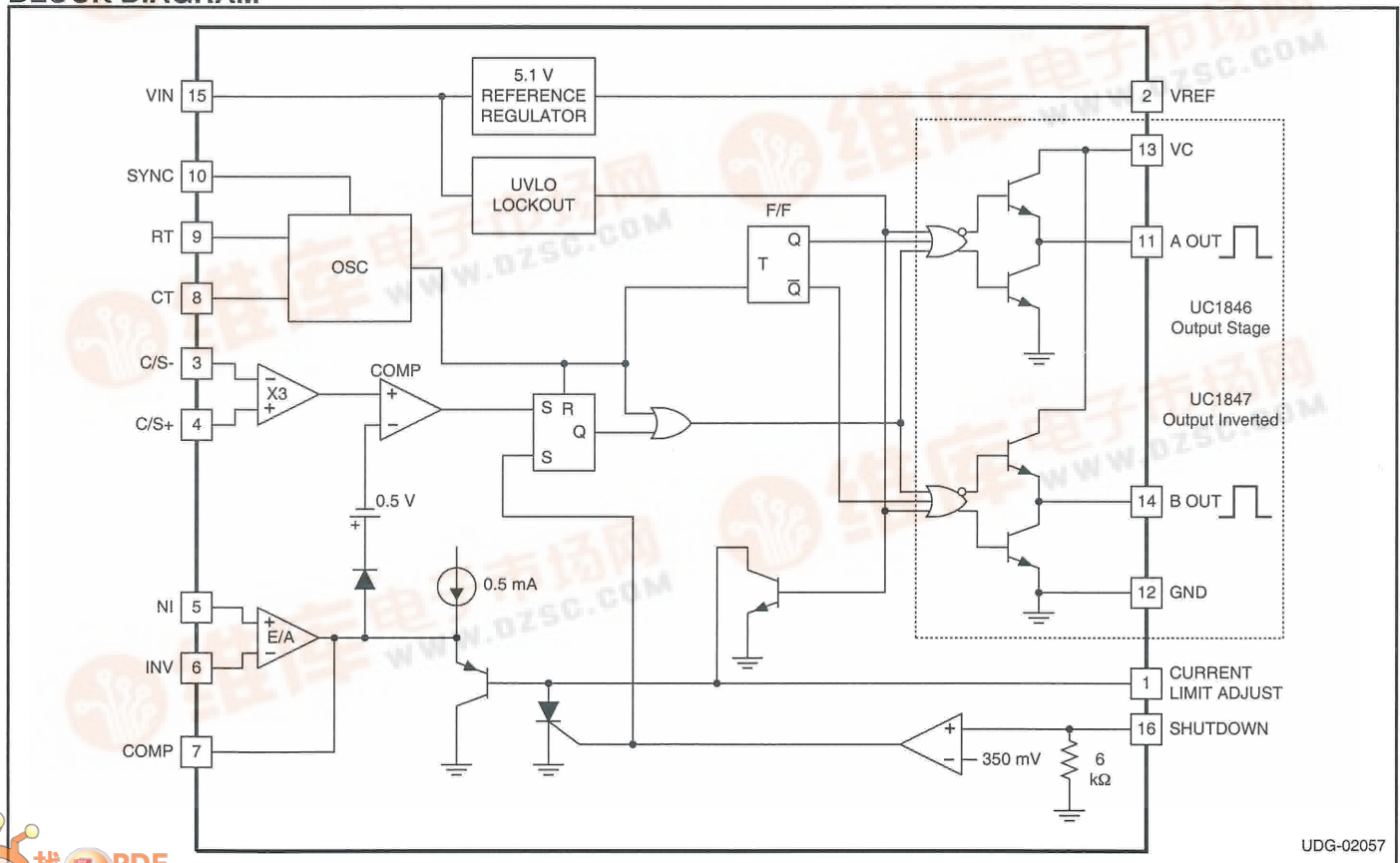

UDG-02057

[查询"UC3846M"供应商](#)

**ABSOLUTE MAXIMUM RATINGS (Note 1)**

Supply Voltage (Pin 15) . . . . .	+40V
Collector Supply Voltage (Pin 13) . . . . .	+40V
Output Current, Source or Sink (Pins 11, 14) . . . . .	500mA
Analog Inputs (Pins 3, 4, 5, 6, 16) . . . . .	-0.3V to +V <sub>IN</sub>
Reference Output Current (Pin 2) . . . . .	-30mA
Sync Output Current (Pin 10) . . . . .	-5mA
Error Amplifier Output Current (Pin 7) . . . . .	-5mA
Soft Start Sink Current (Pin 1) . . . . .	50mA
Oscillator Charging Current (Pin 9) . . . . .	5mA
Power Dissipation at T <sub>A</sub> =25°C . . . . .	1000mW
Power Dissipation at T <sub>C</sub> =25°C . . . . .	2000mW
Storage Temperature Range . . . . .	-65°C to +150°C
Lead Temperature (soldering, 10 seconds) . . . . .	+300°C

Note 1. All voltages are with respect to Ground, Pin 13. Currents are positive into, negative out of the specified terminal. Consult Packaging Section of Databook for thermal limitations and considerations of packages. Pin numbers refer to DIL and SOIC packages only.

**CONNECTION DIAGRAMS**

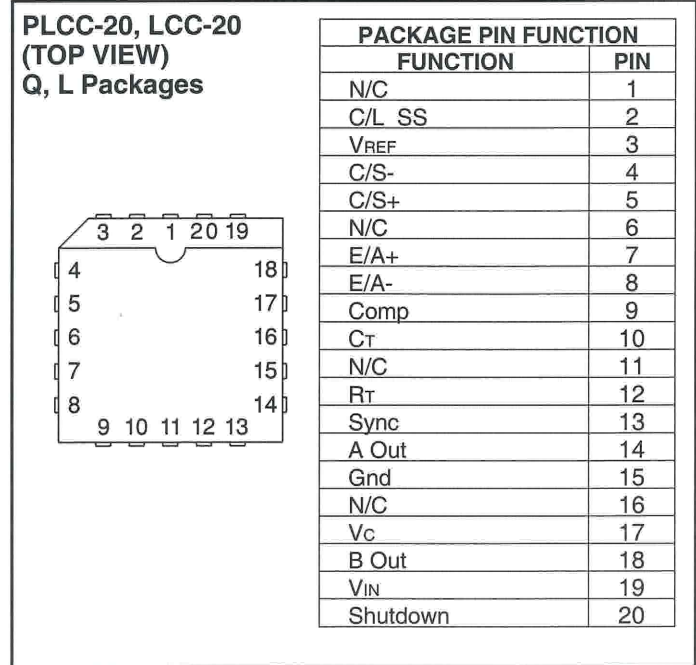
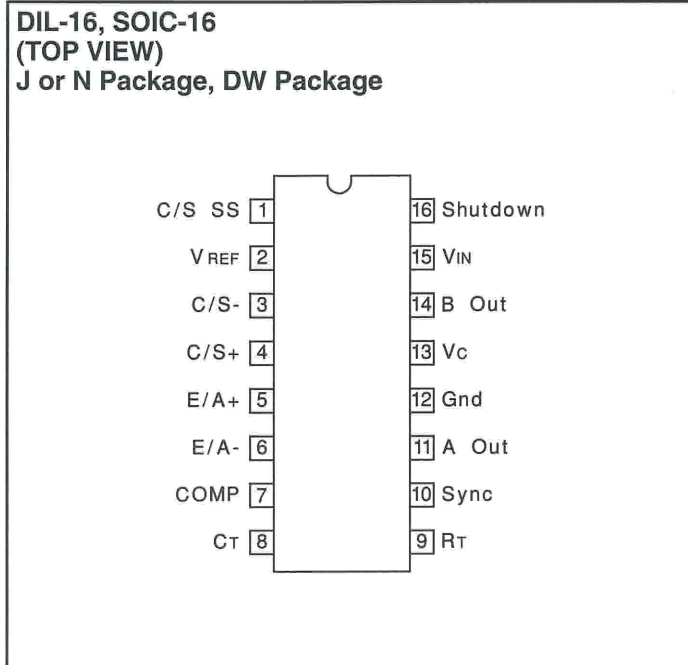

**ELECTRICAL CHARACTERISTICS** (Unless otherwise stated, these specifications apply for T<sub>A</sub>=-55°C to +125°C for UC1846/7; -40°C to +85°C for the UC2846/7; and 0°C to +70°C for the UC3846/7; V<sub>IN</sub>=15V, R<sub>T</sub>=10k, C<sub>T</sub>=4.7nF, T<sub>A</sub>=T<sub>J</sub>.)

PARAMETER	TEST CONDITIONS	UC1846/UC1847 UC2846/UC2847			UC3846/UC3847			UNITS
		MIN.	TYP.	MAX.	MIN.	TYP.	MAX.	
<b>Reference Section</b>								
Output Voltage	T <sub>J</sub> =25°C, I <sub>o</sub> =1mA	5.05	5.10	5.15	5.00	5.10	5.20	V
Line Regulation	V <sub>IN</sub> =8V to 40V		5	20		5	20	mV
Load Regulation	I <sub>L</sub> =1mA to 10mA		3	15		3	15	mV
Temperature Stability	Over Operating Range, (Note 2)		0.4			0.4		mV/°C
Total Output Variation	Line, Load, and Temperature (Note 2)	5.00		5.20	4.95		5.25	V
Output Noise Voltage	10Hz ≤ f ≤ 10kHz, T <sub>J</sub> =25°C (Note 2)		100			100		μV
Long Term Stability	T <sub>J</sub> =125°C, 1000 Hrs. (Note 2)		5			5		mV
Short Circuit Output Current	V <sub>REF</sub> =0V	-10	-45		-10	-45		mA

**ELECTRICAL CHARACTERISTICS (cont.)** (Unless otherwise stated, these specifications apply for  $T_A = -55^\circ\text{C}$  to  $+125^\circ\text{C}$  for UC1846/7;  $-40^\circ\text{C}$  to  $+85^\circ\text{C}$  for the UC2846/7; and  $0^\circ\text{C}$  to  $+70^\circ\text{C}$  for the UC3846/7;  $V_{IN} = 15\text{V}$ ,  $R_T = 10\text{k}$ ,  $C_T = 4.7\text{nF}$ ,  $T_A = T_J$ .)

PARAMETER	TEST CONDITIONS	UC1846/UC1847 UC2846/UC2847			UC3846/UC3847			UNITS
		MIN.	TYP.	MAX.	MIN.	TYP.	MAX.	
<b>Oscillator Section</b>								
Initial Accuracy	$T_J = 25^\circ\text{C}$	39	43	47	39	43	47	kHz
Voltage Stability	$V_{IN} = 8\text{V}$ to $40\text{V}$		-1	2		-1	2	%
Temperature Stability	Over Operating Range (Note 2)		-1			-1		%
Sync Output High Level		3.9	4.35		3.9	4.35		V
Sync Output Low Level			2.3	2.5		2.3	2.5	V
Sync Input High Level	Pin 8=0V	3.9			3.9			V
Sync Input Low Level	Pin 8=0V			2.5			2.5	V
Sync Input Current	Sync Voltage=3.9V, Pin 8=0V		1.3	1.5		1.3	1.5	mA
<b>Error Amp Section</b>								
Input Offset Voltage			0.5	5		0.5	10	mV
Input Bias Current			-0.6	-1		-0.6	-2	$\mu\text{A}$
Input Offset Current			40	250		40	250	nA
Common Mode Range	$V_{IN} = 8\text{V}$ to $40\text{V}$	0		$V_{IN} - 2\text{V}$	0		$V_{IN} - 2\text{V}$	V
Open Loop Voltage Gain	$\Delta V_O = 1.2$ to $3\text{V}$ , $V_{CM} = 2\text{V}$	80	105		80	105		dB
Unity Gain Bandwidth	$T_J = 25^\circ\text{C}$ (Note 2)	0.7	1.0		0.7	1.0		MHz
CMRR	$V_{CM} = 0\text{V}$ to $38\text{V}$ , $V_{IN} = 40\text{V}$	75	100		75	100		dB
PSRR	$V_{IN} = 8\text{V}$ to $40\text{V}$	80	105		80	105		dB
Output Sink Current	$V_{ID} = -15\text{mV}$ to $-5\text{V}$ , $V_{PIN 7} = 1.2\text{V}$	-2	6		-2	6		mA
Output Source Current	$V_{ID} = 15\text{mV}$ to $5\text{V}$ , $V_{PIN 7} = 2.5\text{V}$	-0.4	-0.5		-0.4	-0.5		mA
High Level Output Voltage	$R_L = (\text{Pin } 7) 15\text{k}\Omega$	4.3	4.6		4.3	4.6		V
Low Level Output Voltage			0.7	1		0.7	1	V
<b>Current Sense Amplifier Section</b>								
Amplifier Gain	$V_{PIN 3} = 0\text{V}$ , Pin 1 Open (Notes 3 & 4)	2.5	2.75	3.0	2.5	2.75	3.0	V
Maximum Differential Input Signal ( $V_{PIN 4} - V_{PIN 3}$ )	Pin 1 Open (Note 3) $R_L (\text{Pin } 7) = 15\text{k}\Omega$	1.1	1.2		1.1	1.2		V
Input Offset Voltage	$V_{PIN 1} = 0.5\text{V}$ , Pin 7 Open (Note 3)		5	25		5	25	mV
CMRR	$V_{CM} = 1\text{V}$ to $12\text{V}$	60	83		60	83		dB
PSRR	$V_{IN} = 8\text{V}$ to $40\text{V}$	60	84		60	84		dB
Input Bias Current	$V_{PIN 1} = 0.5\text{V}$ , Pin 7 Open (Note 3)		-2.5	-10		-2.5	-10	$\mu\text{A}$
Input Offset Current	$V_{PIN 1} = 0.5\text{V}$ , Pin 7 Open (Note 3)		0.08	1		0.08	1	$\mu\text{A}$
Input Common Mode Range		0		$V_{IN} - 3$	0		$V_{IN} - 3$	V
Delay to Outputs	$T_J = 25^\circ\text{C}$ , (Note 2)		200	500		200	500	ns
<b>Current Limit Adjust Section</b>								
Current Limit Offset	$V_{PIN 3} = 0\text{V}$ , $V_{PIN 4} = 0\text{V}$ , Pin 7 Open (Note 3)	0.45	0.5	0.55	0.45	0.5	0.55	V
Input Bias Current	$V_{PIN 5} = V_{REF}$ , $V_{PIN 6} = 0\text{V}$		-10	-30		-10	-30	$\mu\text{A}$
<b>Shutdown Terminal Section</b>								
Threshold Voltage		250	350	400	250	350	400	mV
Input Voltage Range		0		$V_{IN}$	0		$V_{IN}$	V
Minimum Latching Current (IPIN 1)	(Note 6)	3.0	1.5		3.0	1.5		mA

**ELECTRICAL CHARACTERISTICS (cont.)**

(Unless otherwise stated, these specifications apply for TA=-55°C to +125°C for UC1846/7; -40°C to +85°C for the UC2846/7; and 0°C to +70°C for the UC3846/7; VIN=15V, RT=10k, CT=4.7nF, TA=TJ.)

PARAMETER	TEST CONDITIONS	UC1846/UC1847 UC2846/UC2847			UC3846/UC3847			UNITS
		MIN.	TYP.	MAX.	MIN.	TYP.	MAX.	
<b>Shutdown Terminal Section (cont.)</b>								
Maximum Non-Latching Current (IPIN 1)	(Note 7)		1.5	0.8		1.5	0.8	mA
Delay to Outputs	TJ=25°C (Note 2)		300	600		300	600	ns
<b>Output Section</b>								
Collector-Emitter Voltage		40			40			V
Collector Leakage Current	VC=40V (Note 5)			200			200	µA
Output Low Level	ISINK=20mA		0.1	0.4		0.1	0.4	V
	ISINK=100mA		0.4	2.1		0.4	2.1	V
Output High Level	ISOURCE=20mA	13	13.5		13	13.5		V
	ISOURCE=100mA	12	13.5		12	13.5		V
Rise Time	CL=1nF, TJ=25°C (Note 2)		50	300		50	300	ns
Fall Time	CL=1nF, TJ=25°C (Note 2)		50	300		50	300	ns
<b>Under-Voltage Lockout Section</b>								
Start-Up Threshold			7.7	8.0		7.7	8.0	V
Threshold Hysteresis			0.75			0.75		V
<b>Total Standby Current</b>								
Supply Current			17	21		17	21	mA

Note 2. These parameters, although ensured over the recommended operating conditions, are not 100% tested in production.

Note 3. Parameter measured at trip point of latch with VPIN 5 = VREF, VPIN 6 = 0V.

Note 4. Amplifier gain defined as:  $G = \frac{\Delta V_{PIN7}}{\Delta V_{PIN4}}$ ;  $V_{PIN4} = 0$  to  $1.0V$

Note 5. Applies to UC1846/UC2846/UC3846 only due to polarity of outputs.

Note 6. Current into Pin 1 ensured to latch circuit in shutdown state.

Note 7. Current into Pin 1 ensured not to latch circuit in shutdown state.

**APPLICATIONS DATA**

**Oscillator Circuit**

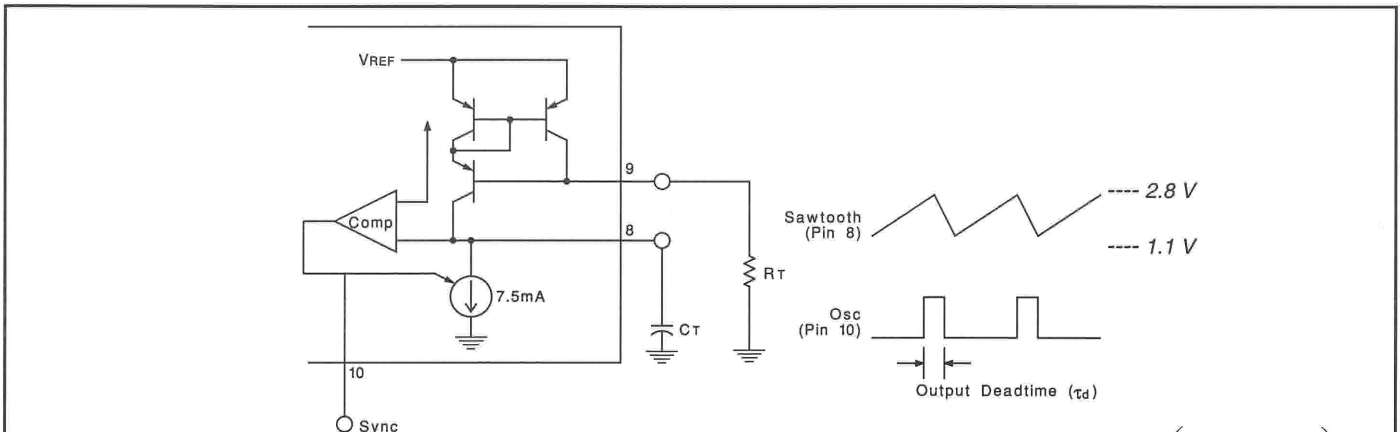

Output deadtime is determined by the external capacitor, CT, according to the formula:  $\tau_d (\mu s) = 145CT (\mu f) \left( \frac{ID}{ID - \frac{3.6}{RT (k\Omega)}} \right)$ .

ID = Oscillator discharge current at 25°C is typically 7.5.

For large values of RT:  $\tau_d (\mu s) \approx 145CT (\mu f)$ .

Oscillator frequency is approximated by the formula:  $fT (kHz) \approx \frac{2.2}{RT (k\Omega) \cdot CT (\mu f)}$ .

[查询"UC3846M"供应商](#)

APPLICATIONS DATA (cont.)

Error Amp Output Configuration

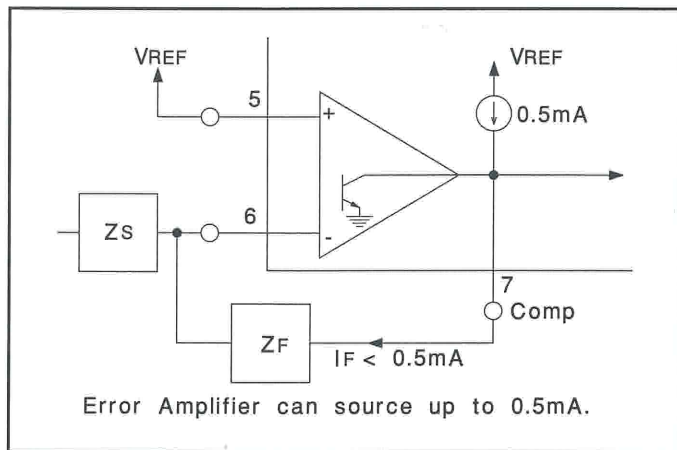

Error Amp Gain and Phase vs Frequency

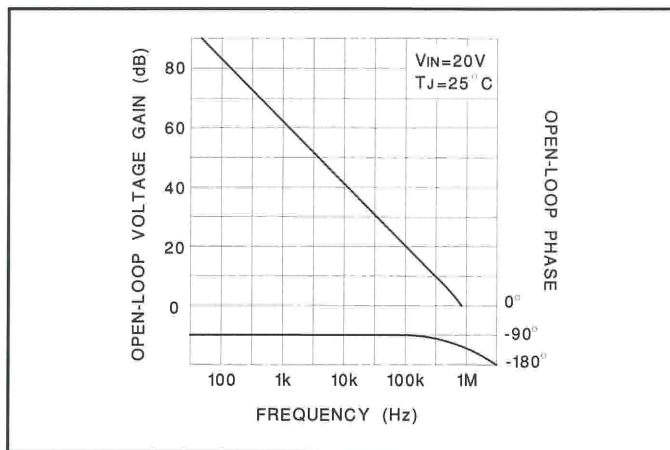

Error Amp Open-Logic D.C. Gain vs Load Resistance

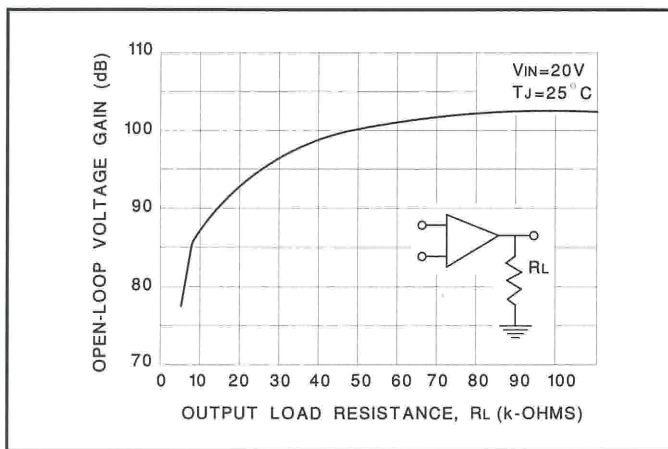

Parallel Operation

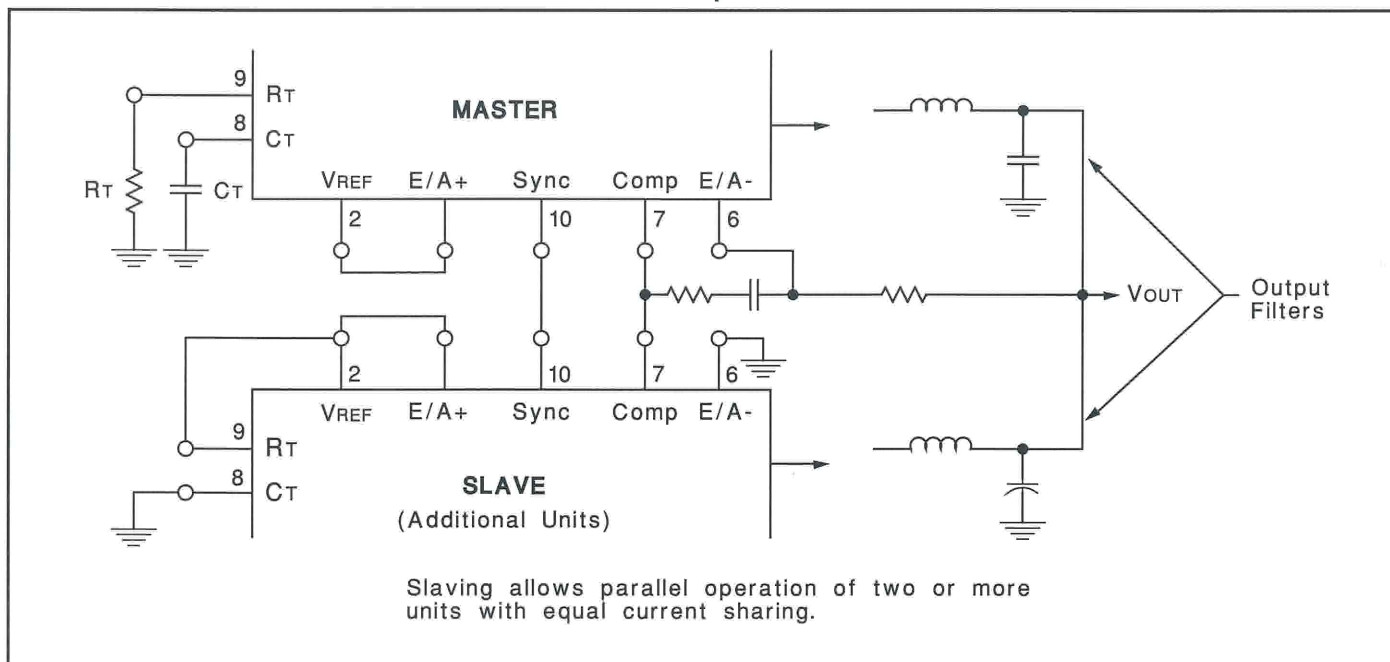

Pulse by Pulse Current Limiting

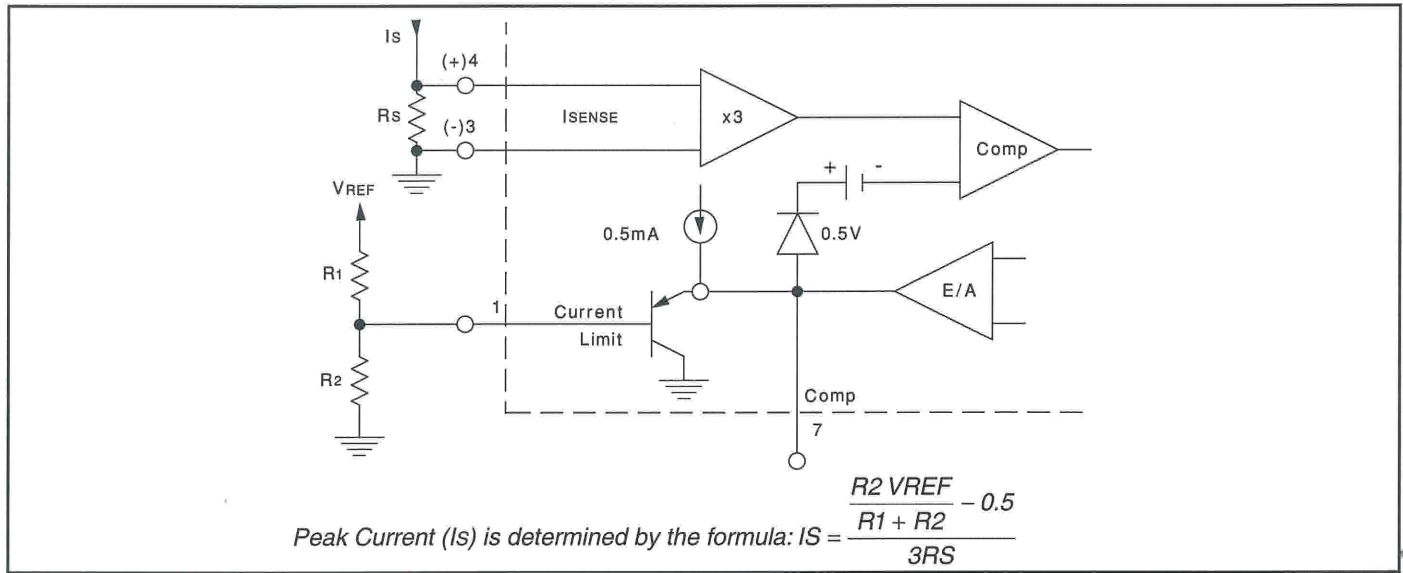

Soft Start and Shutdown /Restart Functions

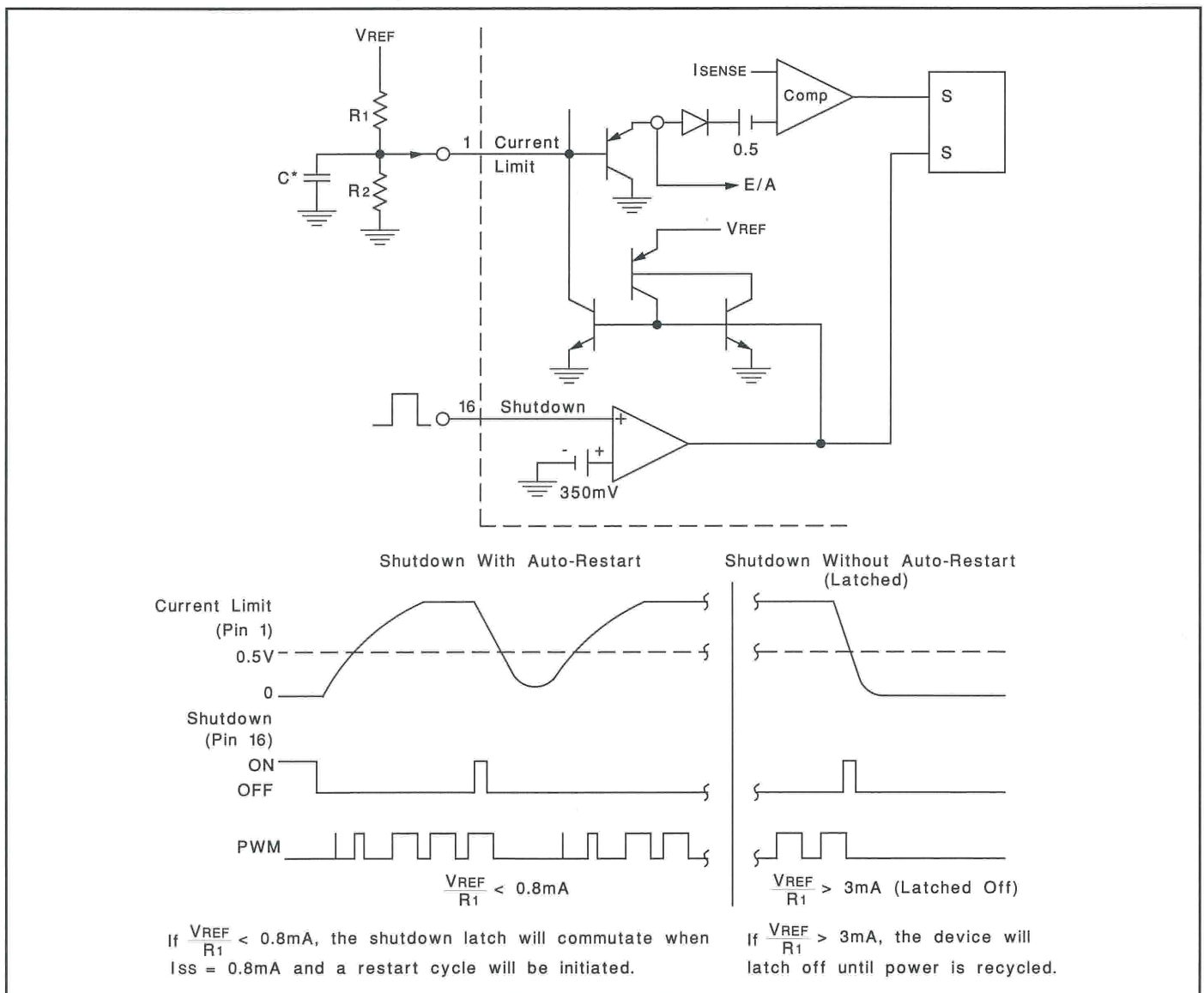

Current Sense Amp Connection

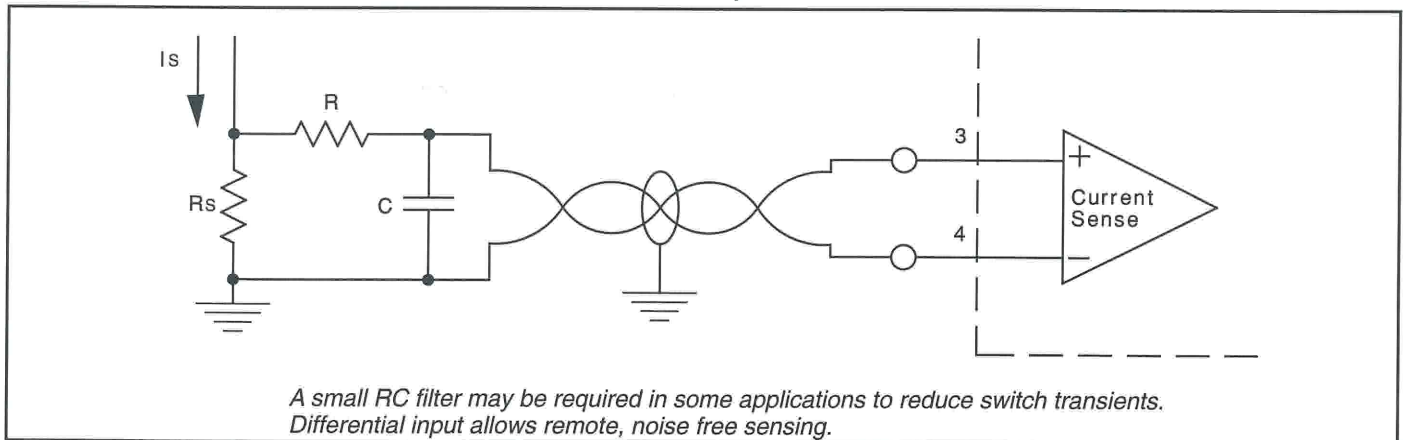

UC1846 Open Loop Test Circuit

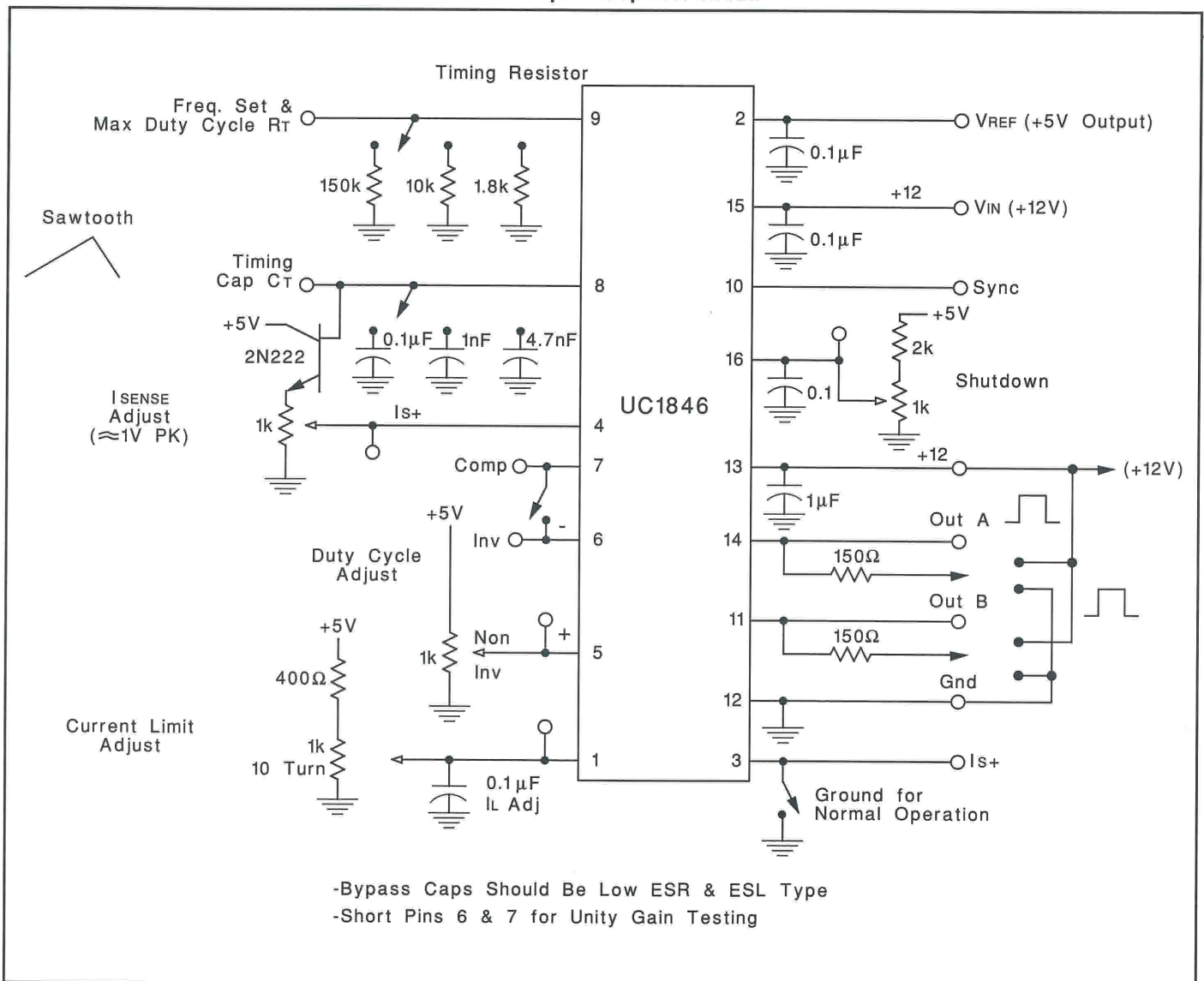

[查询"UC3846M"供应商](#)

## REVISION HISTORY

SLUS352A to SLUS352B July 2010:

- 1) Updated block diagram, page 1.
- 2) Added peak and vally voltages to the Oscillator Circuit, page 4.





www.ti.com

PACKAG

**PACKAGING INFORMATION**

Orderable Device	Status <sup>(1)</sup>	Package Type	Package Drawing	Pins	Package Qty	Eco Plan <sup>(2)</sup>	Lead/Ball Finish	MSL Peak
5962-86806012A	ACTIVE	LCCC	FK	20	1	TBD	POST-PLATE	N / A for Pkg
5962-8680601EA	ACTIVE	CDIP	J	16	1	TBD	A42	N / A for Pkg
UC1846J	ACTIVE	CDIP	J	16	1	TBD	A42	N / A for Pkg
UC1846J/80257	OBSOLETE	CDIP	J	16		TBD	Call TI	Call TI
UC1846J/80364	OBSOLETE	CDIP	J	16		TBD	Call TI	Call TI
UC1846J/80619	OBSOLETE	CDIP	J	16		TBD	Call TI	Call TI
UC1846J883B	ACTIVE	CDIP	J	16	1	TBD	A42	N / A for Pkg
UC1846L883B	ACTIVE	LCCC	FK	20	1	TBD	POST-PLATE	N / A for Pkg
UC1847J	OBSOLETE	CDIP	J	16		TBD	Call TI	Call TI
UC1847J883B	OBSOLETE	CDIP	J	16		TBD	Call TI	Call TI
UC1847L	OBSOLETE	LCCC	FK	20		TBD	Call TI	Call TI
UC1847L883B	OBSOLETE	LCCC	FK	20		TBD	Call TI	Call TI
UC2846DW	ACTIVE	SOIC	DW	16	40	Green (RoHS & no Sb/Br)	CU NIPDAU	Level-2-2600
UC2846DWG4	ACTIVE	SOIC	DW	16	40	Green (RoHS & no Sb/Br)	CU NIPDAU	Level-2-2600
UC2846DWTR	ACTIVE	SOIC	DW	16	2000	Green (RoHS & no Sb/Br)	CU NIPDAU	Level-2-2600
UC2846DWTR/81265	OBSOLETE	SOIC	DW	16		TBD	Call TI	Call TI
UC2846DWTR/81265G4	OBSOLETE	SOIC	DW	16		TBD	Call TI	Call TI
UC2846DWTRG4	ACTIVE	SOIC	DW	16	2000	Green (RoHS & no Sb/Br)	CU NIPDAU	Level-2-2600
UC2846J	ACTIVE	CDIP	J	16	1	TBD	A42	N / A for Pkg
UC2846N	ACTIVE	PDIP	N	16	25	Green (RoHS & no Sb/Br)	CU NIPDAU	N / A for Pkg
UC2846NG4	ACTIVE	PDIP	N	16	25	Green (RoHS & no Sb/Br)	CU NIPDAU	N / A for Pkg



www.ti.com

PACKAG

Orderable Device	Status <sup>(1)</sup>	Package Type	Package Drawing	Pins	Package Qty	Eco Plan <sup>(2)</sup>	Lead/ Ball Finish	MSL Peak
UC2846QTR	ACTIVE	PLCC	FN	20	1000	Green (RoHS & no Sb/Br)	CU SN	Level-2-2600
UC2846QTRG3	ACTIVE	PLCC	FN	20	1000	Green (RoHS & no Sb/Br)	CU SN	Level-2-2600
UC2847DW	ACTIVE	SOIC	DW	16	40	Green (RoHS & no Sb/Br)	CU NIPDAU	Level-2-2600
UC2847DWG4	ACTIVE	SOIC	DW	16	40	Green (RoHS & no Sb/Br)	CU NIPDAU	Level-2-2600
UC2847N	ACTIVE	PDIP	N	16	25	Green (RoHS & no Sb/Br)	CU NIPDAU	N / A for Pkg
UC2847NG4	ACTIVE	PDIP	N	16	25	Green (RoHS & no Sb/Br)	CU NIPDAU	N / A for Pkg
UC3846DW	ACTIVE	SOIC	DW	16	40	Green (RoHS & no Sb/Br)	CU NIPDAU	Level-2-2600
UC3846DWG4	ACTIVE	SOIC	DW	16	40	Green (RoHS & no Sb/Br)	CU NIPDAU	Level-2-2600
UC3846DWTR	ACTIVE	SOIC	DW	16	2000	Green (RoHS & no Sb/Br)	CU NIPDAU	Level-2-2600
UC3846DWTRG4	ACTIVE	SOIC	DW	16	2000	Green (RoHS & no Sb/Br)	CU NIPDAU	Level-2-2600
UC3846J	ACTIVE	CDIP	J	16	1	TBD	A42	N / A for Pkg
UC3846N	ACTIVE	PDIP	N	16	25	Green (RoHS & no Sb/Br)	CU NIPDAU	N / A for Pkg
UC3846NG4	ACTIVE	PDIP	N	16	25	Green (RoHS & no Sb/Br)	CU NIPDAU	N / A for Pkg
UC3846Q	ACTIVE	PLCC	FN	20	46	Green (RoHS & no Sb/Br)	CU SN	Level-2-2600
UC3846QG3	ACTIVE	PLCC	FN	20	46	Green (RoHS & no Sb/Br)	CU SN	Level-2-2600
UC3846QTR	ACTIVE	PLCC	FN	20	1000	Green (RoHS & no Sb/Br)	CU SN	Level-2-2600
UC3846QTRG3	ACTIVE	PLCC	FN	20	1000	Green (RoHS & no Sb/Br)	CU SN	Level-2-2600
UC3847DW	ACTIVE	SOIC	DW	16	40	Green (RoHS & no Sb/Br)	CU NIPDAU	Level-2-2600



www.ti.com

PACKAG

Orderable Device	Status <sup>(1)</sup>	Package Type	Package Drawing	Pins	Package Qty	Eco Plan <sup>(2)</sup>	Lead/ Ball Finish	MSL Peak Temp
UC3847DWG4	ACTIVE	SOIC	DW	16	40	Green (RoHS & no Sb/Br)	CU NIPDAU	Level-2-260C
UC3847J	OBSOLETE	CDIP	J	16		TBD	Call TI	Call TI
UC3847N	ACTIVE	PDIP	N	16	25	Green (RoHS & no Sb/Br)	CU NIPDAU	N / A for Pkg
UC3847NG4	ACTIVE	PDIP	N	16	25	Green (RoHS & no Sb/Br)	CU NIPDAU	N / A for Pkg

<sup>(1)</sup> The marketing status values are defined as follows:

**ACTIVE:** Product device recommended for new designs.

**LIFEBUY:** TI has announced that the device will be discontinued, and a lifetime-buy period is in effect.

**NRND:** Not recommended for new designs. Device is in production to support existing customers, but TI does not recommend using this part in a new design.

**PREVIEW:** Device has been announced but is not in production. Samples may or may not be available.

**OBSOLETE:** TI has discontinued the production of the device.

<sup>(2)</sup> Eco Plan - The planned eco-friendly classification: Pb-Free (RoHS), Pb-Free (RoHS Exempt), or Green (RoHS & no Sb/Br) - please check <http://www.ti.com> for more information and additional product content details.

**TBD:** The Pb-Free/Green conversion plan has not been defined.

**Pb-Free (RoHS):** TI's terms "Lead-Free" or "Pb-Free" mean semiconductor products that are compatible with the current RoHS requirements for all lead not exceed 0.1% by weight in homogeneous materials. Where designed to be soldered at high temperatures, TI Pb-Free products are suitable for high temperature soldering processes.

**Pb-Free (RoHS Exempt):** This component has a RoHS exemption for either 1) lead-based flip-chip solder bumps used between the die and package, or 2) lead-based die attach between the die and leadframe. The component is otherwise considered Pb-Free (RoHS compatible) as defined above.

**Green (RoHS & no Sb/Br):** TI defines "Green" to mean Pb-Free (RoHS compatible), and free of Bromine (Br) and Antimony (Sb) based flame retardants (both in homogeneous material).

<sup>(3)</sup> MSL, Peak Temp. -- The Moisture Sensitivity Level rating according to the JEDEC industry standard classifications, and peak solder temperature.

**Important Information and Disclaimer:** The information provided on this page represents TI's knowledge and belief as of the date that it is provided. TI disclaims any warranty, expressed or implied, for the information provided by third parties, and makes no representation or warranty as to the accuracy of such information. Efforts are underway to better integrate information from third parties into TI's data sheets and Datasheets. TI continues to take reasonable steps to provide representative and accurate information but may not have conducted destructive testing or chemical analysis on all TI and TI suppliers consider certain information to be proprietary, and thus CAS numbers and other limited information may not be available for release. TI is not responsible for any errors or omissions in this information.

In no event shall TI's liability arising out of such information exceed the total purchase price of the TI part(s) at issue in this document sold by TI to Customer.

**OTHER QUALIFIED VERSIONS OF UC1846, UC1847, UC2846, UC2846M, UC3846, UC3846M, UC3847 :**

- Catalog: [UC3846](#), [UC3847](#), [UC2846](#), [UC3846M](#), [UC3846](#)



www.ti.com

PACKAG

- 
- Enhanced Product: [UC1846-EP](#), [UC1846-EP](#)
  - Military: [UC2846M](#), [UC1846](#), [UC1847](#)
  - Space: [UC1846-SP](#), [UC1846-SP](#)

NOTE: Qualified Version Definitions:

- Catalog - TI's standard catalog product
- Enhanced Product - Supports Defense, Aerospace and Medical Applications
- Military - QML certified for Military and Defense Applications
- Space - Radiation tolerant, ceramic packaging and qualified for use in Space-based application

**TAPE AND REEL INFORMATION**

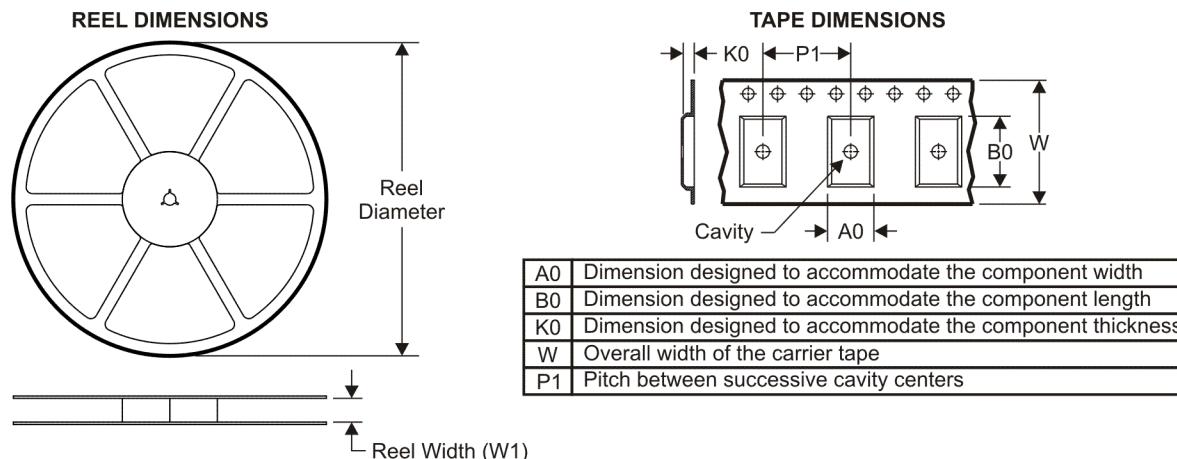

**QUADRANT ASSIGNMENTS FOR PIN 1 ORIENTATION IN TAPE**

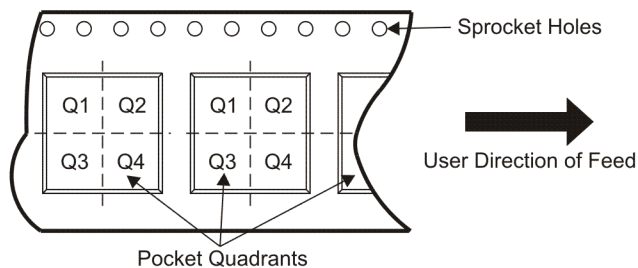

\*All dimensions are nominal

Device	Package Type	Package Drawing	Pins	SPQ	Reel Diameter (mm)	Reel Width W1 (mm)	A0 (mm)	B0 (mm)	K0 (mm)	P1 (mm)	W (mm)	Pin1 Quadrant
UC2846DWTR	SOIC	DW	16	2000	330.0	16.4	10.85	10.8	2.7	12.0	16.0	Q1
UC2846QTR	PLCC	FN	20	1000	330.0	16.4	10.3	10.3	4.9	12.0	16.0	Q1
UC3846DWTR	SOIC	DW	16	2000	330.0	16.4	10.85	10.8	2.7	12.0	16.0	Q1
UC3846QTR	PLCC	FN	20	1000	330.0	16.4	10.3	10.3	4.9	12.0	16.0	Q1

**TAPE AND REEL BOX DIMENSIONS**



\*All dimensions are nominal

Device	Package Type	Package Drawing	Pins	SPQ	Length (mm)	Width (mm)	Height (mm)
UC2846DWTR	SOIC	DW	16	2000	346.0	346.0	33.0
UC2846QTR	PLCC	FN	20	1000	346.0	346.0	33.0
UC3846DWTR	SOIC	DW	16	2000	346.0	346.0	33.0
UC3846QTR	PLCC	FN	20	1000	346.0	346.0	33.0

## IMPORTANT NOTICE

Texas Instruments Incorporated and its subsidiaries (TI) reserve the right to make corrections, modifications, enhancements, improvements, and other changes to its products and services at any time and to discontinue any product or service without notice. Customers should obtain the latest relevant information before placing orders and should verify that such information is current and complete. All products are sold subject to TI's terms and conditions of sale supplied at the time of order acknowledgment.

TI warrants performance of its hardware products to the specifications applicable at the time of sale in accordance with TI's standard warranty. Testing and other quality control techniques are used to the extent TI deems necessary to support this warranty. Except where mandated by government requirements, testing of all parameters of each product is not necessarily performed.

TI assumes no liability for applications assistance or customer product design. Customers are responsible for their products and applications using TI components. To minimize the risks associated with customer products and applications, customers should provide adequate design and operating safeguards.

TI does not warrant or represent that any license, either express or implied, is granted under any TI patent right, copyright, mask work right, or other TI intellectual property right relating to any combination, machine, or process in which TI products or services are used. Information published by TI regarding third-party products or services does not constitute a license from TI to use such products or services or a warranty or endorsement thereof. Use of such information may require a license from a third party under the patents or other intellectual property of the third party, or a license from TI under the patents or other intellectual property of TI.

Reproduction of TI information in TI data books or data sheets is permissible only if reproduction is without alteration and is accompanied by all associated warranties, conditions, limitations, and notices. Reproduction of this information with alteration is an unfair and deceptive business practice. TI is not responsible or liable for such altered documentation. Information of third parties may be subject to additional restrictions.

Resale of TI products or services with statements different from or beyond the parameters stated by TI for that product or service voids all express and any implied warranties for the associated TI product or service and is an unfair and deceptive business practice. TI is not responsible or liable for any such statements.

TI products are not authorized for use in safety-critical applications (such as life support) where a failure of the TI product would reasonably be expected to cause severe personal injury or death, unless officers of the parties have executed an agreement specifically governing such use. Buyers represent that they have all necessary expertise in the safety and regulatory ramifications of their applications, and acknowledge and agree that they are solely responsible for all legal, regulatory and safety-related requirements concerning their products and any use of TI products in such safety-critical applications, notwithstanding any applications-related information or support that may be provided by TI. Further, Buyers must fully indemnify TI and its representatives against any damages arising out of the use of TI products in such safety-critical applications.

TI products are neither designed nor intended for use in military/aerospace applications or environments unless the TI products are specifically designated by TI as military-grade or "enhanced plastic." Only products designated by TI as military-grade meet military specifications. Buyers acknowledge and agree that any such use of TI products which TI has not designated as military-grade is solely at the Buyer's risk, and that they are solely responsible for compliance with all legal and regulatory requirements in connection with such use.

TI products are neither designed nor intended for use in automotive applications or environments unless the specific TI products are designated by TI as compliant with ISO/TS 16949 requirements. Buyers acknowledge and agree that, if they use any non-designated products in automotive applications, TI will not be responsible for any failure to meet such requirements.

Following are URLs where you can obtain information on other Texas Instruments products and application solutions:

<b>Products</b>		<b>Applications</b>	
Amplifiers	<a href="http://amplifier.ti.com">amplifier.ti.com</a>	Audio	<a href="http://www.ti.com/audio">www.ti.com/audio</a>
Data Converters	<a href="http://dataconverter.ti.com">dataconverter.ti.com</a>	Automotive	<a href="http://www.ti.com/automotive">www.ti.com/automotive</a>
DLP® Products	<a href="http://www.dlp.com">www.dlp.com</a>	Communications and Telecom	<a href="http://www.ti.com/communications">www.ti.com/communications</a>
DSP	<a href="http://dsp.ti.com">dsp.ti.com</a>	Computers and Peripherals	<a href="http://www.ti.com/computers">www.ti.com/computers</a>
Clocks and Timers	<a href="http://www.ti.com/clocks">www.ti.com/clocks</a>	Consumer Electronics	<a href="http://www.ti.com/consumer-apps">www.ti.com/consumer-apps</a>
Interface	<a href="http://interface.ti.com">interface.ti.com</a>	Energy	<a href="http://www.ti.com/energy">www.ti.com/energy</a>
Logic	<a href="http://logic.ti.com">logic.ti.com</a>	Industrial	<a href="http://www.ti.com/industrial">www.ti.com/industrial</a>
Power Mgmt	<a href="http://power.ti.com">power.ti.com</a>	Medical	<a href="http://www.ti.com/medical">www.ti.com/medical</a>
Microcontrollers	<a href="http://microcontroller.ti.com">microcontroller.ti.com</a>	Security	<a href="http://www.ti.com/security">www.ti.com/security</a>
RFID	<a href="http://www.ti-rfid.com">www.ti-rfid.com</a>	Space, Avionics & Defense	<a href="http://www.ti.com/space-avionics-defense">www.ti.com/space-avionics-defense</a>
RF/IF and ZigBee® Solutions	<a href="http://www.ti.com/lprf">www.ti.com/lprf</a>	Video and Imaging	<a href="http://www.ti.com/video">www.ti.com/video</a>
		Wireless	<a href="http://www.ti.com/wireless-apps">www.ti.com/wireless-apps</a>