

查询"5962-8685401EA"供应商



REVISIONS			
LTR	DESCRIPTION	DATE	APPROVED



REV																		
PAGE																		
REV STATUS OF PAGES	REV																	
	PAGES	1	2	3	4	5	6	7	8	9	10	11	12	13				

Defense Electronics Supply Center Dayton, Ohio Original date of drawing: 15 January 1987 AMSC N/A	PREPARED BY <i>Greg A. Pitz</i>	MILITARY DRAWING
	CHECKED BY <i>DD Di Enzo</i>	This drawing is available for use by all Departments and Agencies of the Department of Defense TITLE: MICROCIRCUITS, DIGITAL, HIGH-SPEED CMOS, BINARY COUNTER, FOUR BIT, MONOLITHIC SILICON
APPROVED BY <i>W.C. Howard</i>	SIZE: A CODE IDENT. NO.: 14933	DWG NO. 5962 - 86854
REV:	PAGE 1 OF 13	5962-E138-3

DISTRIBUTION STATEMENT A. Approved for public release; distribution is unlimited.
 DESC FORM 193
 MAY 86



1. SCOPE

1.1 Scope. This drawing describes device requirements for class B microcircuits in accordance with 1.2.1 of MIL-STD-883, "Provisions for the use of MIL-STD-883 in conjunction with compliant non-JAN devices".

1.2 Part number. The complete part number shall be as shown in the following example:

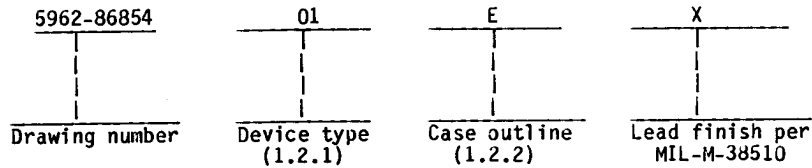

1.2.1 Device type. The device type shall identify the circuit function as follows:

<u>Device type</u>	<u>Generic number</u>	<u>Circuit function</u>
01	54HCT161	4-bit synchronous binary counter with asynchronous clear and LSTTL compatible inputs

1.2.2 Case outline. The case outline shall be as designated in appendix C of MIL-M-38510, and as follows:

<u>Outline letter</u>	<u>Case outline</u>
E	D-2 (16-lead, 1/4" x 7/8"), dual-in-line package.

1.3 Absolute maximum ratings. 1/

Supply voltage range - - - - -	-0.5 V dc to +7.0 V dc
DC input voltage - - - - -	-0.5 V dc to $V_{CC} + 0.5$ V dc
DC output voltage - - - - -	-0.5 V dc to $V_{CC} + 0.5$ V dc
Clamp diode current - - - - -	± 20 mA
DC output current (per pin) - - - - -	± 25 mA
DC V_{CC} or GND current (per pin) - - - - -	± 50 mA
Storage temperature range - - - - -	-65°C to +150°C
Power dissipation, (P_D) - - - - -	500 mW 2/
Lead temperature (soldering, 10 seconds) - - - - -	+260°C
Thermal resistance, junction-to-case (θ_{JC}):	
Case E - - - - -	See MIL-M-38510, appendix C
Junction temperature (T_J) - - - - -	+175°C

1/ Unless otherwise specified, all voltages are referenced to ground.

2/ For $T_C = +100^\circ\text{C}$ to $+125^\circ\text{C}$, derate linearly at 12 mW/ $^\circ\text{C}$.

MILITARY DRAWING DEFENSE ELECTRONICS SUPPLY CENTER DAYTON, OHIO	SIZE A	CODE IDENT. NO. 14933	DWG NO. 5962-86854
		REV	PAGE 2



1.4 Recommended operating conditions.

Supply voltage (V_{CC})	-----	+4.5 V dc to +5.5 V dc
Case operating temperature range (T_C)	-----	-55°C to +125°C
Input rise or fall time:		
$V_{CC} = 4.5$ V	-----	0 to 500 ns
Maximum clock frequency (f_{MAX}):		
$T_C = +25^\circ\text{C}$:		
$V_{CC} = 4.5$ V	-----	20 MHz
$T_C = -55^\circ\text{C}$ to $+125^\circ\text{C}$:		
$V_{CC} = 4.5$ V	-----	13 MHz
Minimum pulse width, clock, clear or load:		
$T_C = +25^\circ\text{C}$:		
$V_{CC} = 4.5$ V	-----	20 ns
$T_C = -55^\circ\text{C}$ to $+125^\circ\text{C}$:		
$V_{CC} = 4.5$ V	-----	30 ns
Minimum setup time, clear, load, enable or data to clock:		
$T_C = +25^\circ\text{C}$:		
$V_{CC} = 4.5$ V	-----	40 ns
$T_C = -55^\circ\text{C}$ to $+125^\circ\text{C}$:		
$V_{CC} = 4.5$ V	-----	60 ns
Minimum hold time, data from clock:		
$T_C = +25^\circ\text{C}$:		
$V_{CC} = 4.5$ V	-----	10 ns
$T_C = -55^\circ\text{C}$ to $+125^\circ\text{C}$:		
$V_{CC} = 4.5$ V	-----	15 ns
Minimum removal time, clear to clock:		
$T_C = +25^\circ\text{C}$:		
$V_{CC} = 4.5$ V	-----	25 ns
$T_C = -55^\circ\text{C}$ to $+125^\circ\text{C}$:		
$V_{CC} = 4.5$ V	-----	37 ns

2. APPLICABLE DOCUMENTS

2.1 Government specification and standard. Unless otherwise specified, the following specification and standard, of the issue listed in that issue of the Department of Defense Index of Specifications and Standards specified in the solicitation, form a part of this drawing to the extent specified herein.

SPECIFICATION

MILITARY

MIL-M-38510 - Microcircuits, General Specification for.

STANDARD

MILITARY

MIL-STD-883 - Test Methods and Procedures for Microelectronics.

(Copies of the specification and standard required by manufacturers in connection with specific acquisition functions should be obtained from the contracting activity or as directed by the contracting activity.)

MILITARY DRAWING DEFENSE ELECTRONICS SUPPLY CENTER DAYTON, OHIO	SIZE	CODE IDENT. NO.	DWG NO.
	A	14933	5962-86854
	REV	PAGE	3

TABLE I. Electrical performance characteristics.

Test	Symbol	Conditions -55°C ≤ T _C ≤ +125°C +4.5 V dc ≤ V _{CC} ≤ 5.5 V dc (unless otherwise specified)	Group A subgroups	Limits		Unit	
				Min	Max		
High level output voltage	V _{OH}	V _{IN} = V _{IH} or V _{IH} = V _{IH} or V _{IH} = V _{IH} or V _{CC} = 4.5 V	1,2,3		4.4	V	
					3.7		
Low level output voltage	V _{OL}	V _{IN} = V _{IH} or V _{IH} = V _{IH} or V _{IH} = V _{IH} or V _{CC} = 4.5 V			0.1		
					0.4		
High level input voltage	V _{IH}				2.0		
Low level input voltage	V _{IL}				0.8		
Input leakage current	I _{IN}	V _{IN} = V _{CC} or GND; V _{CC} = 5.5 V			-1.0	1.0	μA
Quiescent current	I _{CC}	V _{IN} = V _{CC} or GND; I _{OUT} = 0 μA; V _{CC} = 5.5 V				160	
Additional quiescent current	ΔI _{CC}	V _{IN} = 2.4 V or 0.5 V, any 1 input; V _{IN} = V _{CC} or GND, other pins; V _{CC} = 5.5 V; I _{OUT} = 0 μA				1.8	mA
Input capacitance	C _{IN}	V _{CC} = 4.5 V; T _C = +25°C See 4.3.1c	4			10	μF
Functional tests		See 4.3.1d	7				
Propagation delay time, clock to ripple carry output	t _{PHL1} , t _{PLH1}	V _{CC} = 4.5 V C _L = 50 pF ±10% See figure 4	T _C = +25°C	9		45	ns
			T _C = -55°C, +125°C	10,11		68	
Propagation delay time, clock to any Q output	t _{PHL2} , t _{PLH2}		T _C = +25°C	9		43	
			T _C = -55°C, +125°C	10,11		65	

See footnote at end of table.

MILITARY DRAWING DEFENSE ELECTRONICS SUPPLY CENTER DAYTON, OHIO	SIZE A	CODE IDENT. NO. 14933	DWG NO. 5962-86854
		REV	PAGE 4

TABLE I. Electrical performance characteristics - Continued.

Test	Symbol	Conditions -55°C < T _C ≤ +125°C 4.5 V dc < V _{CC} < 5.5 V dc (unless otherwise specified)	Group A subgroups	Limits		Unit	
				Min	Max		
Propagation delay time, enable T to ripple carry output	t _{PHL3} , t _{PLH3}	V _{CC} = 4.5 V C _L = 50 pF ±10% See figure 4	T _C = +25°C	9		39	ns
			T _C = -55°C, +125°C	10,11		58	
Propagation delay time, clear to any Q output	t _{PHL4}		T _C = +25°C	9		50	
			T _C = -55°C, +125°C	10,11		75	
Transition times ^{2/}	t _{TLH} , t _{THL}		T _C = +25°C	9		15	
			T _C = -55°C, +125°C	10,11		22	

1/ For a power supply of 5 V ± 10%, the worst case output voltages (V_{OH} and V_{OL}) occur for HCT at 4.5 V. Thus, the 4.5 V values should be used when designing with this supply. Worst case V_{IH} and V_{IL} occur at V_{CC} = 5.5 V and 4.5 V, respectively.

2/ Transition times (t_{THL}, t_{TLH}), if not tested, shall be guaranteed to the specified parameters.

2.2 Order of precedence. In the event of a conflict between the text of this drawing and the references cited herein, the text of this drawing shall take precedence.

3. REQUIREMENTS

3.1 Item requirements. The individual item requirements shall be in accordance with 1.2.1 of MIL-STD-883, "Provisions for the use of MIL-STD-883 in conjunction with compliant non-JAN devices" and as specified herein.

3.2 Design, construction, and physical dimensions. The design, construction, and physical dimensions shall be as specified in MIL-M-38510 and herein.

3.2.1 Terminal connections. The terminal connections shall be as specified on figure 1.

3.2.2 Truth table. The truth table shall be as specified on figure 2.

3.2.3 Logic diagram. The logic diagram shall be as specified on figure 3.

3.2.4 Case outline. The case outline shall be in accordance with 1.2.2 herein.

3.3 Electrical performance characteristics. Unless otherwise specified, the electrical performance characteristics are as specified in table I and apply over the full recommended case operating temperature range.

3.4 Marking. Marking shall be in accordance with MIL-STD-883 (see 3.1 herein). The part shall be marked with the part number listed in 1.2 herein. In addition, the manufacturer's part number may also be marked as listed in 6.4 herein.

MILITARY DRAWING DEFENSE ELECTRONICS SUPPLY CENTER DAYTON, OHIO	SIZE	CODE IDENT. NO.	DWG NO.
	A	14933	5962-86854
		REV	PAGE 5

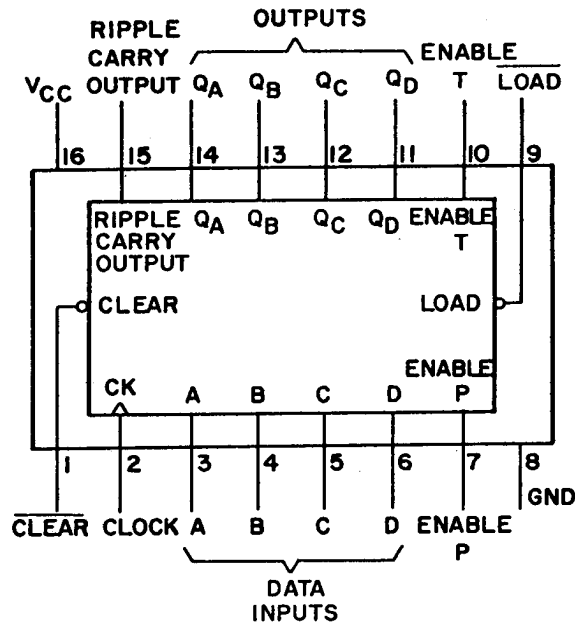

FIGURE 1. Terminal connections (top view).

CLK	CLR	ENP	ENT	Load	Function
X	L	X	X	X	Clear
X	H	H	L	H	Count & RC disabled
X	H	L	H	H	Count disabled
X	H	L	L	H	Count & RC disabled
↑	H	X	X	L	Load
↑	H	H	H	H	Increment Counter

FIGURE 2. Truth table.

MILITARY DRAWING DEFENSE ELECTRONICS SUPPLY CENTER DAYTON, OHIO	SIZE	CODE IDENT. NO.	DWG NO.
	A	14933	5962-86854
	REV	PAGE	6

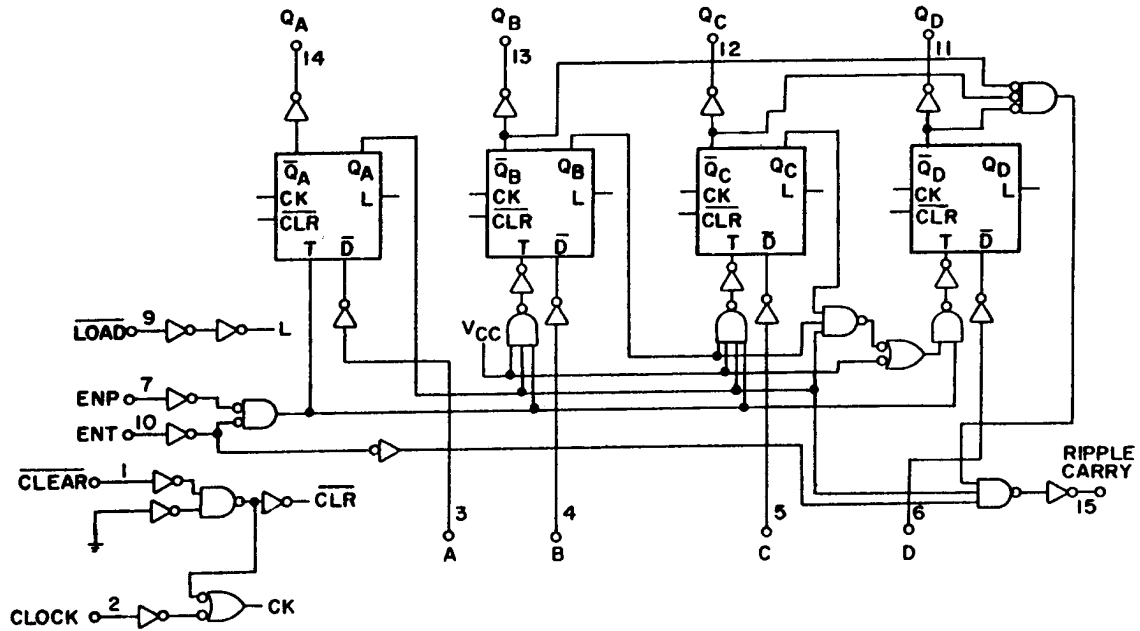

FIGURE 3. Logic diagram.

MILITARY DRAWING DEFENSE ELECTRONICS SUPPLY CENTER DAYTON, OHIO	SIZE A	CODE IDENT. NO. 14933	DWG NO. 5962-86854
		REV	PAGE 7

DESC FORM 193A
FEB 86

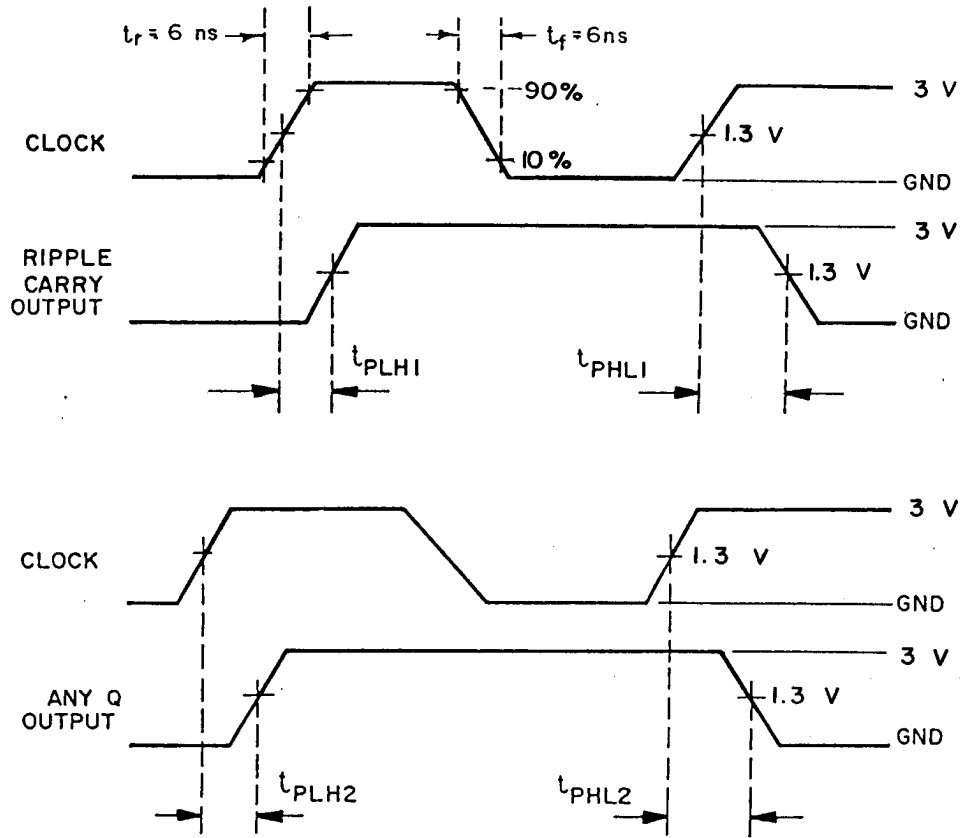

FIGURE 4. Switching time waveforms.

MILITARY DRAWING DEFENSE ELECTRONICS SUPPLY CENTER DAYTON, OHIO	SIZE	CODE IDENT. NO.	DWG NO.
	A	14933	5962-86854
	REV	PAGE	8

DESC FORM 193A
FEB 86

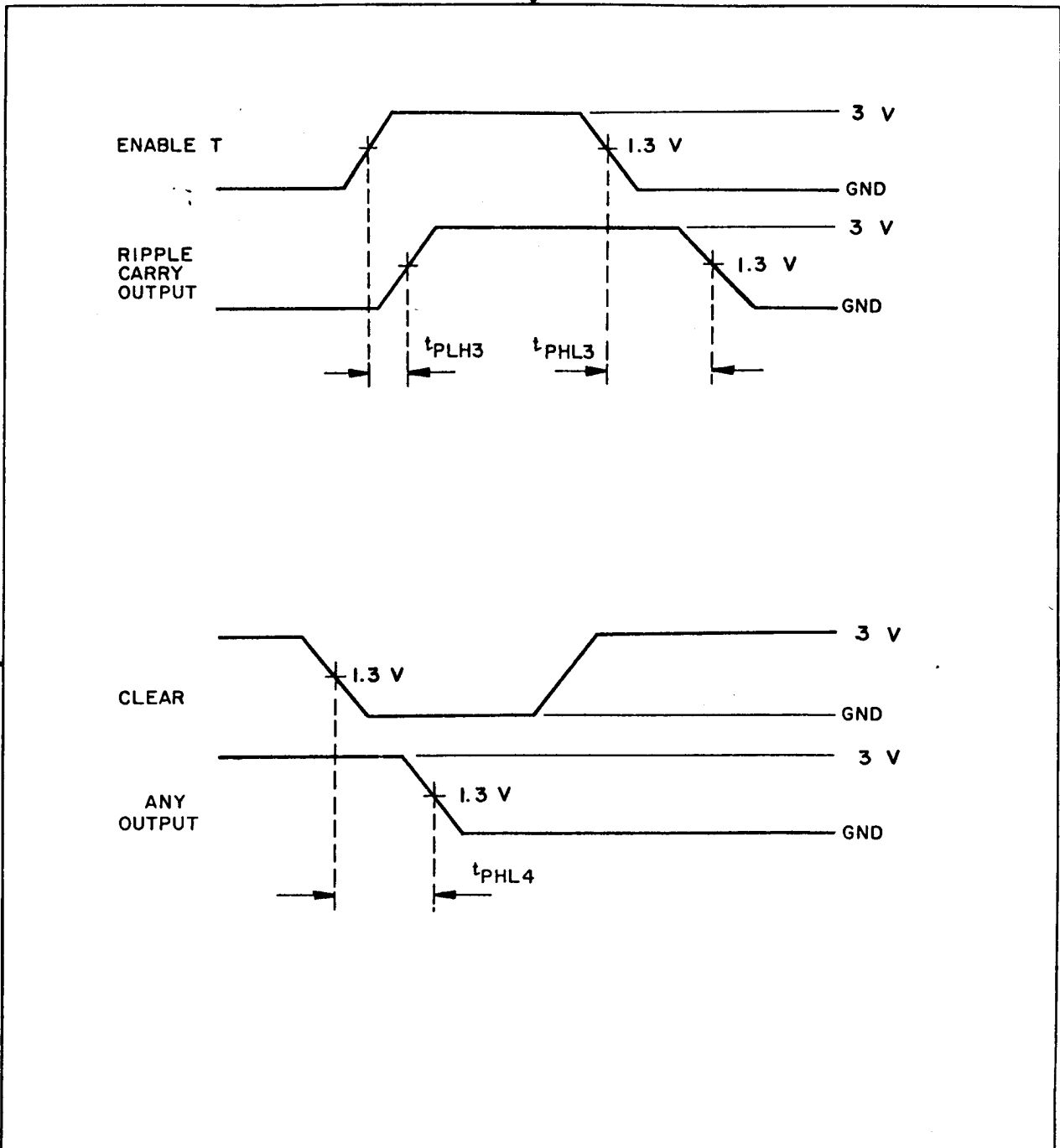
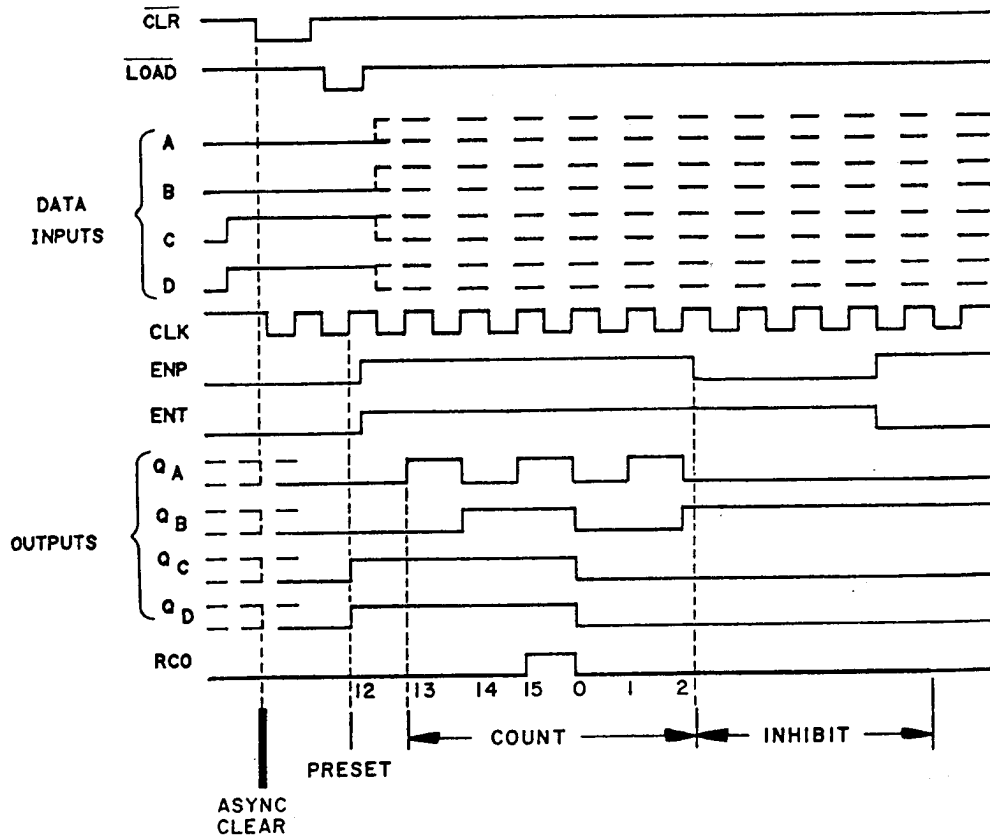

FIGURE 4. Switching time waveforms - Continued.

MILITARY DRAWING DEFENSE ELECTRONICS SUPPLY CENTER DAYTON, OHIO	SIZE A	CODE IDENT. NO. 14933	DWG NO. 5962-86854
		REV	PAGE 9

DESC FORM 193A
FEB 86



- Sequence as follows:
1. Clear outputs to zero.
 2. Preset to binary twelve.
 3. Count to thirteen, fourteen, fifteen, zero, one and two.
 4. Inhibit.

FIGURE 5. Counting sequence.

MILITARY DRAWING DEFENSE ELECTRONICS SUPPLY CENTER DAYTON, OHIO	SIZE	CODE IDENT. NO.	DWG NO.
	A	14933	5962-86854
		REV	PAGE 10

DESC FORM 193A
FEB 86

3.5 Certificate of compliance. A certificate of compliance shall be required from a manufacturer in order to be listed as an approved source of supply in 6.4. The certificate of compliance submitted to DESC-ECS prior to listing as an approved source of supply shall state that the manufacturer's product meets the requirements of MIL-STD-883 (see 3.1 herein) and the requirements herein.

3.6 Certificate of conformance. A certificate of conformance as required in MIL-STD-883 (see 3.1 herein) shall be provided with each lot of microcircuits delivered to this drawing.

3.7 Notification of change. Notification of change to DESC-ECS shall be required in accordance with MIL-STD-883 (see 3.1 herein).

3.8 Verification and review. DESC, DESC's agent, and the acquiring activity retain the option to review the manufacturer's facility and applicable required documentation. Offshore documentation shall be made available onshore at the option of the reviewer.

4. QUALITY ASSURANCE PROVISIONS

4.1 Sampling and inspection. Sampling and inspection procedures shall be in accordance with section 4 of MIL-M-38510 to the extent specified in MIL-STD-883 (see 3.1 herein).

4.2 Screening. Screening shall be in accordance with method 5004 of MIL-STD-883, and shall be conducted on all devices prior to quality conformance inspection. The following additional criteria shall apply:

- a. Burn-in test (method 1015 of MIL-STD-883).
 - (1) Test condition A, B, C, or D using the circuit submitted with the certificate of compliance (see 3.5 herein).
 - (2) $T_A = +125^{\circ}\text{C}$, minimum.
- b. Interim and final electrical test parameters shall be as specified in table II herein, except interim electrical parameter tests prior to burn-in are optional at the discretion of the manufacturer.

TABLE II. Electrical test requirements.

MIL-STD-883 test requirements	Subgroups (per method 5005, table I)
Interim electrical parameters (method 5004)	
Final electrical test parameters (method 5004)	1*,2,3,9
Group A test requirements (method 5005)	1,2,3,4,7,9, 10,11
Groups C and D end-point electrical parameters (method 5005)	1,2,3
Additional electrical subgroups for group C periodic inspections	- - - -

*PDA applies to subgroup 1.

MILITARY DRAWING DEFENSE ELECTRONICS SUPPLY CENTER DAYTON, OHIO	SIZE A	CODE IDENT. NO. 14933	DWG NO. 5962-86854
		REV	PAGE 11



4.3 Quality conformance inspection. Quality conformance inspection shall be in accordance with method 5005 of MIL-STD-883 including groups A, B, C, and D inspections. The following additional criteria shall apply.

4.3.1 Group A inspection.

- a. Tests shall be as specified in table II herein.
- b. Subgroups 5, 6, and 8 in table I, method 5005 of MIL-STD-883 shall be omitted.
- c. Subgroup 4 (C_{IN} measurement) shall be measured only for the initial test and after process or design changes which may affect input capacitance.
- d. Subgroup 7 tests sufficient to verify the truth table.

4.3.2 Groups C and D inspections.

- a. End-point electrical parameters shall be as specified in table II herein.
- b. Steady-state life test (method 1005 of MIL-STD-883) conditions:
 - (1) Test condition A, B, C, or D using the circuit submitted with the certificate of compliance (see 3.5 herein).
 - (2) $T_A = +125^{\circ}C$, minimum.
 - (3) Test duration: 1,000 hours, except as permitted by appendix B of MIL-M-38510 and method 1005 of MIL-STD-883.

5. PACKAGING

5.1 Packaging requirements. The requirements for packaging shall be in accordance with MIL-M-38510.

6. NOTES

6.1 Intended use. Microcircuits conforming to this drawing are intended for use when military specifications do not exist and qualified military devices that will perform the required function are not available for OEM application. When a military specification exists and the product covered by this drawing has been qualified for listing on QPL-38510, the device specified herein will be inactivated and will not be used for new design. The QPL-38510 product shall be the preferred item for all applications.

6.2 Replaceability. Microcircuits covered by this drawing will replace the same generic device covered by a contractor-prepared specification or drawing.

6.3 Comments. Comments on this drawing should be directed to DESC-ECS, Dayton, Ohio 45444, or telephone 513-296-5375.

MILITARY DRAWING DEFENSE ELECTRONICS SUPPLY CENTER DAYTON, OHIO	SIZE A	CODE IDENT. NO. 14933	DWG NO. 5962-86854
		REV	PAGE 12

DESC FORM 193A
FEB 86





6.4 Approved source of supply. An approved source of supply is listed herein. Additional sources will be added as they become available. The vendor listed herein has agreed to this drawing and a certificate of compliance (see 3.5 herein) has been submitted to DESC-ECS.

Military drawing part number	Vendor CAGE number	Vendor similar part number ^{1/}
5962-8685401EX	18714	CD54HCT151F/3A

^{1/} Caution. Do not use this number for item acquisition. Items acquired to this number may not satisfy the performance requirements of this drawing.

Vendor CAGE number
18714

Vendor name and address
RCA Corporation
Route 202
Somerville, NJ 08875



MILITARY DRAWING DEFENSE ELECTRONICS SUPPLY CENTER DAYTON, OHIO	SIZE A	CODE IDENT. NO. 14933	DWG NO. 5962-86854
		REV	PAGE 13

DESC FORM 193A
FEB 86

