



POWER MANAGEMENT IC FOR LI-ION POWERED SYSTEMS

FEATURES

- 1.2 A, 97% Efficient Step-Down Converter for System Voltage (VDCDC1)
- 1 A, Up to 95% Efficient Step-Down Converter for Memory Voltage (VDCDC2)
- 900 mA, 90% Efficient Step-Down Converter for Processor Core (VDCDC3)
- 30 mA LDO/Switch for Real Time Clock (VRTC)
- 2 x 200 mA General-Purpose LDO
- Dynamic Voltage Management for Processor Core
- Preselectable LDO Voltage Using Two Digital Input Pins
- Externally Adjustable Reset Delay Time
- Battery Backup Functionality
- Separate Enable Pins for Inductive Converters
- I²C™ Compatible Serial Interface
- 85- μ A Quiescent Current
- Low Ripple PFM Mode
- Thermal Shutdown Protection
- 40-Pin 6 mm x 6 mm QFN Package

APPLICATIONS

- PDA
- Cellular/Smart Phone
- Internet Audio Player
- Digital Still Camera
- Digital Radio Player
- Split Supply TMS320™ DSP Family and μ P Solutions:
OMAP™1610, OMAP1710, OMAP330, XScale Bulverde, Samsung ARM-Based Processors, etc.
- Intel® PXA270, etc.

DESCRIPTION

The TPS65022 is an integrated Power Management IC for applications powered by one Li-Ion or Li-Polymer cell, and which require multiple power rails. The TPS65022 provides three highly efficient, step-down converters targeted at providing the core voltage, peripheral, I/O and memory rails in a processor based system. All three step-down converters enter a low-power mode at light load for maximum efficiency across the widest possible range of load currents. The TPS65022 also integrates two general-purpose 200 mA LDO voltage regulators, which are enabled with an external input pin. Each LDO operates with an input voltage range between 1.5 V and 6.5 V, allowing them to be supplied from one of the step-down converters or directly from the battery. The default output voltage of the LDOs can be digitally set to 4 different voltage combinations using the DEFLDO1 and DEFLDO2 pins. The serial interface can be used for dynamic voltage scaling, masking interrupts, or for dis/enabling and setting the LDO output voltages. The interface is compatible with the Fast/Standard mode I²C specification, allowing transfers at up to 400 kHz. The TPS65022 is available in a 40-pin (RHA) QFN package, and operates over a free-air temperature of -40°C to 85°C.



Please be aware that an important notice concerning availability, standard warranty, and use in critical applications of Texas Instruments semiconductor products and disclaimers thereto appears at the end of this data sheet.

TMS320, OMAP, PowerPAD are trademarks of Texas Instruments.
Intel is a registered trademark of Intel Corporation.
I2C is a trademark of Philips Electronics.

PRODUCTION DATA information is current as of publication date. Products conform to specifications per the terms of the Texas Instruments standard warranty. Production processing does not necessarily include testing of all parameters.

Copyright © 2006, Texas Instruments Incorporated





These devices have limited built-in ESD protection. The leads should be shorted together or the device placed in conductive foam during storage or handling to prevent electrostatic damage to the MOS gates.

ORDERING INFORMATION

T_A	PACKAGE ⁽¹⁾	PART NUMBER ⁽²⁾
–40°C to 85°C	40 pin QFN (RHA)	TPS65022RHA

- (1) For the most current package and ordering information, see the Package Option Addendum at the end of this document, or see the TI Web site at www.ti.com.
- (2) The RHA package is available in tape and reel. Add the R suffix (TPS65022RHAR) to order quantities of 2500 parts per reel. Add the T suffix (TPS65022RHAT) to order quantities of 250 parts per reel.

ABSOLUTE MAXIMUM RATINGS⁽¹⁾

over operating free-air temperature range (unless otherwise noted)

	VALUE	UNIT
V_I Input voltage range on all pins except AGND and PGND pins with respect to AGND	–0.3 to 7	V
Current at VINDCDC1, L1, PGND1, VINDCDC2, L2, PGND2, VINDCDC3, L3, PGND3	2000	mA
Peak current at all other pins	1000	mA
Continuous total power dissipation	See Dissipation Rating Table	
T_A Operating free-air temperature	–40 to 85	°C
T_J Maximum junction temperature	125	°C
T_{stg} Storage temperature	–65 to 150	°C

- (1) Stresses beyond those listed under *absolute maximum ratings* may cause permanent damage to the device. These are stress ratings only and functional operation of the device at these or any other conditions beyond those indicated under *recommended operating conditions* is not implied. Exposure to absolute-maximum-rated conditions for extended periods may affect device reliability.

DISSIPATION RATINGS

PACKAGE	$T_A \leq 25^\circ\text{C}$ POWER RATING	DERATING FACTOR ABOVE $T_A = 25^\circ\text{C}$	$T_A = 70^\circ\text{C}$ POWER RATING	$T_A = 85^\circ\text{C}$ POWER RATING
RHA ⁽¹⁾⁽²⁾	2.85 W	28 mW/°C	1.57 W	1.14 W

- (1) The thermal resistance junction to ambient of the RHA package is 35°C/W measured on a high K board.
- (2) The thermal resistance junction to case (exposed pad) of the RHA package is 5°C/W.

RECOMMENDED OPERATING CONDITIONS

over operating free-air temperature range (unless otherwise noted)

	MIN	NOM	MAX	UNIT
V_{CC} Input voltage range step-down convertors (VINDCDC1, VINDCDC2, VINDCDC3)	2.5		6	V
V_O	Output voltage range for VDCDC1 step-down convertor ⁽¹⁾	0.6	VINDCDC1	V
	Output voltage range for VDCDC2 (mem) step-down convertor ⁽¹⁾	0.6	VINDCDC2	
	Output voltage range for VDCDC3 (core) step-down convertor ⁽¹⁾	0.6	VINDCDC3	
V_I Input voltage range for LDOs (VINLDO1, VINLDO2)	1.5		6.5	V
V_O Output voltage range for LDOs (VLDO1, VLDO2)	1		VINLDO1-2	V
$I_{O(DCDC2)}$ Output current at L1			1200	mA
Inductor at L1 ⁽²⁾	2.2	3.3		μH
$C_{I(DCDC1)}$ Input capacitor at VINDCDC1 ⁽²⁾	10			μF
$C_{O(DCDC1)}$ Output capacitor at VDCDC1 ⁽²⁾	10	22		μF
$I_{O(DCDC2)}$ Output current at L2			1000	mA
Inductor at L2 ⁽²⁾	2.2	3.3		μH

- (1) When using an external resistor divider at DEFDCDC3, DEFDCDC2, DEFDCDC1
- (2) See applications section for more information.

RECOMMENDED OPERATING CONDITIONS (continued)

over operating free-air temperature range (unless otherwise noted)

		MIN	NOM	MAX	UNIT
$C_{I(DCDC2)}$	Input capacitor at VINDCDC2 ⁽²⁾	10			μF
$C_{O(DCDC2)}$	Output capacitor at VDCDC2 ⁽²⁾	10	22		μF
$I_{O(DCDC3)}$	Output current at L3			900	mA
	Inductor at L3 ⁽²⁾	2.2	3.3		μH
$C_{I(DCDC3)}$	Input capacitor at VINDCDC3 ⁽²⁾	10			μF
$C_{O(DCDC3)}$	Output capacitor at VDCDC3 ⁽²⁾	10	22		μF
$C_{I(VCC)}$	Input capacitor at VCC ⁽²⁾	1			μF
$C_{I(VINLDO)}$	Input capacitor at VINLDO ⁽²⁾	1			μF
$C_{O(VLDO1-2)}$	Output capacitor at VLDO1, VLDO2 ⁽²⁾	2.2			μF
$I_{O(VLDO1-2)}$	Output current at VLDO1, VLDO2			200	mA
$C_{O(VRTC)}$	Output capacitor at VRTC ⁽³⁾	4.7			μF
T_A	Operating ambient temperature	-40		85	$^{\circ}\text{C}$
T_J	Operating junction temperature	-40		125	$^{\circ}\text{C}$
	Resistor from VINDCDC3, VINDCDC2, VINDCDC1 to VCC used for filtering ⁽⁴⁾		1	10	Ω

(3) See applications section for more information.

(4) Up to 3 mA can flow into V_{CC} when all 3 converters are running in PWM. This resistor causes the UVLO threshold to be shifted accordingly.

ELECTRICAL CHARACTERISTICS

VINDCDC1 = VINDCDC2 = VINDCDC3 = VCC = VINLDO = 3.6 V, VBACKUP = 3 V, $T_A = -40^{\circ}\text{C}$ to 85°C , typical values are at $T_A = 25^{\circ}\text{C}$ (unless otherwise noted)

PARAMETER	TEST CONDITIONS	MIN	TYP	MAX	UNIT
CONTROL SIGNALS : SCLK, SDAT (input), DCDC1_EN, DCDC2_EN, DCDC3_EN, LDO_EN, DEFLDO1, DEFLDO2					
V_{IH}	High level input voltage	Rpullup at SCLK and SDAT = 4.7 k Ω , pulled to VRTC		VCC	V
V_{IL}	Low level input voltage	Rpullup at SCLK and SDAT = 4.7 k Ω , pulled to VRTC		0.4	V
I_H	Input bias current		0.01	0.1	μA
CONTROL SIGNALS : HOT_RESET					
V_{IH}	High level input voltage			VCC	V
V_{IL}	Low level input voltage			0.4	V
I_{IB}	Input bias current		0.01	0.1	μA
t_{glitch}	Deglitch time at HOT_RESET	25	30	35	ms
CONTROL SIGNALS : LOWBAT, PWRFAIL, RESPWRON, INT, SDAT (output)					
V_{OH}	High level output voltage			6	V
V_{OL}	Low level output voltage	$I_{IL} = 5 \text{ mA}$		0.3	V
	Duration of low pulse at RESPWRON	External capacitor 1 nF		100	ms
	Resetpwron threshold	-3%	2.4	3%	V
	Resetpwron threshold	-3%	2.52	3%	V

ELECTRICAL CHARACTERISTICS

VINDCDC1 = VINDCDC2 = VINDCDC3 = VCC = VINLDO = 3.6 V, VBACKUP = 3 V, T_A = -40°C to 85°C, typical values are at T_A = 25°C (unless otherwise noted)

PARAMETER	TEST CONDITIONS	MIN	TYP	MAX	UNIT	
SUPPLY PINS: VCC, VINDCDC1, VINDCDC2, VINDCDC3						
I _(q)	Operating quiescent current, PFM	All 3 DCDC converters enabled, zero load and no switching, LDOs enabled	VCC = 3.6 V, VBACKUP = 3 V; V _(VSYN) = 0 V	85	100	μA
		All 3 DCDC converters enabled, zero load and no switching, LDOs off	VCC = 3.6 V, VBACKUP = 3 V; V _(VSYN) = 0 V	78	90	
		DCDC1 and DCDC2 converters enabled, zero load and no switching, LDOs off	VCC = 3.6 V, VBACKUP = 3 V; V _(VSYN) = 0 V	57	70	
		DCDC1 converter enabled, zero load and no switching, LDOs off	VCC = 3.6 V, VBACKUP = 3 V; V _(VSYN) = 0 V	43	55	
I _I	Current into VCC; PWM	All 3 DCDC converters enabled and running in PWM, LDOs off	VCC = 3.6 V, VBACKUP = 3 V; V _(VSYN) = 0 V	2	3	mA
		DCDC1 and DCDC2 converters enabled and running in PWM, LDOs off	VCC = 3.6 V, VBACKUP = 3 V; V _(VSYN) = 0 V	1.5	2.5	
		DCDC1 converter enabled and running in PWM, LDOs off	VCC = 3.6 V, VBACKUP = 3 V; V _(VSYN) = 0 V	0.85	2	
I _(q)	Quiescent current	All converters disabled, LDOs off	VCC = 3.6 V, VBACKUP = 3 V; V _(VSYN) = 0 V	23	33	μA
			VCC = 2.6 V, VBACKUP = 3 V; V _(VSYN) = 0 V	3.5	5	μA
			VCC = 3.6 V, VBACKUP = 0 V; V _(VSYN) = 0 V		43	μA

ELECTRICAL CHARACTERISTICS

VINDCDC1 = VINDCDC2 = VINDCDC3 = VCC = VINLDO = 3.6 V, VBACKUP = 3 V, T_A = -40°C to 85°C, typical values are at T_A = 25°C (unless otherwise noted)

PARAMETER		TEST CONDITIONS	MIN	TYP	MAX	UNIT
SUPPLY PINS: VBACKUP, VSYSIN, VRTC						
I _(q)	Operating quiescent current	VBACKUP = 3 V, VSYSIN = 0 V; VCC = 2.6 V, current into VBACKUP		20	33	μA
I _(SD)	Operating quiescent current	VBACKUP < V _{VBACKUP} , current into VBACKUP		2	3	μA
	VRTC LDO output voltage	VSYSIN = VBACKUP = 0 V, I _O = 0 mA		3		V
I _O	Output current for VRTC	VSYSIN < 2.57 V and VBACKUP < 2.57 V			30	mA
	VRTC short-circuit current limit	VRTC = GND; VSYSIN = VBACKUP = 0 V			100	mA
	Maximum output current at VRTC for RESPWRON = 1	VRTC > 2.6 V, V _{CC} = 3 V; VSYSIN = VBACKUP = 0 V	30			mA
V _O	Output voltage accuracy for VRTC	VSYSIN = VBACKUP = 0 V; I _O = 0 mA	-1%		1%	
	Line regulation for VRTC	VCC = VRTC + 0.5 V to 6.5 V, I _O = 5 mA	-1%		1%	
	Load regulation VRTC	I _O = 1 mA to 30 mA; VSYSIN = VBACKUP = 0 V	-3%		1%	
	Regulation time for VRTC	Load change from 10% to 90%		10		μs
I _{lkg}	Input leakage current at VSYSIN	VSYSIN < V _{VSYSIN}			2	μA
	r _{DS(on)} of VSYSIN switch				12.5	Ω
	r _{DS(on)} of VBACKUP switch				12.5	Ω
	Input voltage range at VBACKUP ⁽¹⁾		2.73		3.75	V
	Input voltage range at VSYSIN ⁽¹⁾		2.73		3.75	V
	VSYSIN threshold	VSYSIN falling	-3%	2.55	3%	V
	VSYSIN threshold	VSYSIN rising	-3%	2.65	3%	V
	VBACKUP threshold	VBACKUP falling	-3%	2.55	3%	V
	VBACKUP threshold	VBACKUP falling	-3%	2.65	3%	V
SUPPLY PIN: VINLDO						
I _(q)	Operating quiescent current	Current per LDO into VINLDO		16	30	μA
I _(SD)	Shutdown current	Total current for both LDOs into VINLDO, VLDO = 0 V		0.1	1	μA

(1) Based on the requirements for the Intel PXA270 processor.

ELECTRICAL CHARACTERISTICS

VINDCDC1 = VINDCDC2 = VINDCDC3 = VCC = VINLDO = 3.6 V, VBACKUP = 3 V, T_A = -40°C to 85°C, typical values are at T_A = 25°C (unless otherwise noted)

PARAMETER		TEST CONDITIONS	MIN	TYP	MAX	UNIT
VDCDC1 STEP-DOWN CONVERTER						
V _I	Input voltage range, VINDCDC1		2.5		6	V
I _O	Maximum output current		1200			mA
I _(SD)	Shutdown supply current in VINDCDC1	DCDC1_EN = GND		0.1	1	μA
r _{DS(on)}	P-channel MOSFET on-resistance	VINDCDC1 = V _(GS) = 3.6 V		125	261	mΩ
I _{lkg}	P-channel leakage current	VINDCDC1 = 6 V			2	μA
r _{DS(on)}	N-channel MOSFET on-resistance	VINDCDC1 = V _(GS) = 3.6 V		130	260	mΩ
I _{lkg}	N-channel leakage current	V _(DS) = 6 V		7	10	μA
	Forward current limit (P- and N-channel)	2.5 V < V _{I(MAIN)} < 6 V	1.55	1.75	1.95	A
f _S	Oscillator frequency		1.3	1.5	1.7	MHz
Fixed output voltage FPWMDCDC1=0	3 V	VINDCDC1 = 3.3 V to 6 V; 0 mA ≤ I _O ≤ 1.2 A	-2%		2%	
	3.3 V	VINDCDC1 = 3.6 V to 6 V; 0 mA ≤ I _O ≤ 1.2 A	-2%		2%	
Fixed output voltage FPWMDCDC1=1	3 V	VINDCDC1 = 3.3 V to 6 V; 0 mA ≤ I _O ≤ 1.2 A	-1%		1%	
	3.3 V	VINDCDC1 = 3.6 V to 6 V; 0 mA ≤ I _O ≤ 1.2 A	-1%		1%	
Adjustable output voltage with resistor divider at DEFDCDC1; FPWMDCDC1=0		VINDCDC1 = VDCDC1 + 0.3 V (min 2.5 V) to 6 V; 0 mA ≤ I _O ≤ 1.2 A	-2%		2%	
Adjustable output voltage with resistor divider at DEFDCDC1; FPWMDCDC1=1		VINDCDC1 = VDCDC1 + 0.3 V (min 2.5 V) to 6 V; 0 mA ≤ I _O ≤ 1.2 A	-1%		1%	
Line Regulation		VINDCDC1 = VDCDC1 + 0.3 V (min. 2.5 V) to 6 V; I _O = 10 mA		0		%/V
Load Regulation		I _O = 10 mA to 1200 mA		0.25		%/A
Soft start ramp time		VDCDC1 ramping from 5% to 95% of target value		750		μs
Internal resistance from L1 to GND				1		MΩ
VDCDC1 discharge resistance		DCDC1 discharge = 1		300		Ω

ELECTRICAL CHARACTERISTICS

VINDCDC1 = VINDCDC2 = VINDCDC3 = VCC = VINLDO = 3.6 V, VBACKUP = 3 V, T_A = –40°C to 85°C, typical values are at T_A = 25°C (unless otherwise noted)

PARAMETER		TEST CONDITIONS	MIN	TYP	MAX	UNIT
VDCDC2 STEP-DOWN CONVERTER						
V _I	Input voltage range, VINDCDC2		2.5		6	V
I _O	Maximum output current		1000			mA
I _(SD)	Shutdown supply current in VINDCDC2	DCDC2_EN = GND		0.1	1	μA
r _{DS(on)}	P-channel MOSFET on-resistance	VINDCDC2 = V _(GS) = 3.6 V		140	300	mΩ
I _{lkg}	P-channel leakage current	VINDCDC2 = 6 V			2	μA
r _{DS(on)}	N-channel MOSFET on-resistance	VINDCDC2 = V _(GS) = 3.6 V		150	297	mΩ
I _{lkg}	N-channel leakage current	V _(DS) = 6 V		7	10	μA
I _{LIMF}	Forward current limit (P- and N-channel)	2.5 V < VINDCDC2 < 6 V	1.4	1.55	1.7	A
f _S	Oscillator frequency		1.3	1.5	1.7	MHz
Fixed output voltage FPWMDCDC2=0	1.8 V	VINDCDC2 = 2.5 V to 6 V; 0 mA ≤ I _O ≤ 1 A	–2%		2%	
	2.5 V	VINDCDC2 = 2.8 V to 6 V; 0 mA ≤ I _O ≤ 1 A	–2%		2%	
Fixed output voltage FPWMDCDC2=1	1.8 V	VINDCDC2 = 2.5 V to 6 V; 0 mA ≤ I _O ≤ 1 A	–2%		2%	
	2.5 V	VINDCDC2 = 2.8 V to 6 V; 0 mA ≤ I _O ≤ 1 A	–1%		1%	
Adjustable output voltage with resistor divider at DEFDCDC2 FPWMDCDC2=0		VINDCDC2 = VDCDC2 + 0.3 V (min 2.5 V) to 6 V; 0 mA ≤ I _O ≤ 1 A	–2%		2%	
Adjustable output voltage with resistor divider at DEFDCDC2; FPWMDCDC2=1		VINDCDC2 = VDCDC2 + 0.3 V (min 2.5 V) to 6 V; 0 mA ≤ I _O ≤ 1 A	–1%		1%	
Line Regulation		VINDCDC2 = VDCDC2 + 0.3 V (min. 2.5 V) to 6 V; I _O = 10 mA		0		%/V
Load Regulation		I _O = 10 mA to 1 mA		0.25		%/A
Soft start ramp time		VDCDC2 ramping from 5% to 95% of target value		750		μs
Internal resistance from L2 to GND				1		MΩ
VDCDC2 discharge resistance		DCDC2 discharge =1		300		Ω

ELECTRICAL CHARACTERISTICS

VINDCDC1 = VINDCDC2 = VINDCDC3 = VCC = VINLDO = 3.6 V, VBACKUP = 3 V, T_A = -40°C to 85°C, typical values are at T_A = 25°C (unless otherwise noted)

PARAMETER		TEST CONDITIONS	MIN	TYP	MAX	UNIT
VDCDC3 STEP-DOWN CONVERTER						
V _I	Input voltage range, VINDCDC3		2.5		6	V
I _O	Maximum output current		900			mA
I _(SD)	Shutdown supply current in VINDCDC3	DCDC3_EN = GND		0.1	1	μA
r _{DS(on)}	P-channel MOSFET on-resistance	VINDCDC3 = V _(GS) = 3.6 V		310	698	mΩ
I _{lkg}	P-channel leakage current	VINDCDC3 = 6 V		0.1	2	μA
r _{DS(on)}	N-channel MOSFET on-resistance	VINDCDC3 = V _(GS) = 3.6 V		220	503	mΩ
I _{lkg}	N-channel leakage current	V _(DS) = 6 V		7	10	μA
	Forward current limit (P- and N-channel)	2.5 V < VINDCDC3 < 6 V	1.15	1.34	1.52	A
f _S	Oscillator frequency		1.3	1.5	1.7	MHz
	Fixed output voltage FPWMDCDC3=0	All VDCDC3	VINDCDC3 = 2.5 V to 6 V; 0 mA ≤ I _O ≤ 800 mA		-2%	2%
	Fixed output voltage FPWMDCDC3=1		VINDCDC3 = 2.5 V to 6 V; 0 mA ≤ I _O ≤ 800 mA		-1%	1%
	Adjustable output voltage with resistor divider at DEFDCDC3 FPWMDCDC3=0	VINDCDC3 = VDCDC3 + 0.5 V (min 2.5 V) to 6 V; 0 mA ≤ I _O ≤ 800 mA		-2%	2%	
	Adjustable output voltage with resistor divider at DEFDCDC3; FPWMDCDC3=1	VINDCDC3 = VDCDC3 + 0.5 V (min 2.5 V) to 6 V; 0 mA ≤ I _O ≤ 800 mA		-1%	1%	
	Line Regulation	VINDCDC3 = VDCDC3 + 0.3 V (min. 2.5 V) to 6 V; I _O = 10 mA		0		%/V
	Load Regulation	I _O = 10 mA to 400 mA		0.25		%/A
	Soft start ramp time	VDCDC3 ramping from 5% to 95% of target value		750		μs
	Internal resistance from L3 to GND			1		MΩ
	VDCDC3 discharge resistance	DCDC3 discharge =1		300		Ω

ELECTRICAL CHARACTERISTICS

VINDCDC1 = VINDCDC2 = VINDCDC3 = VCC = VINLDO = 3.6 V, VBACKUP = 3 V, T_A = –40°C to 85°C, typical values are at T_A = 25°C (unless otherwise noted)

PARAMETER		TEST CONDITIONS	MIN	TYP	MAX	UNIT
VLDO1 and VLDO2 LOW DROPOUT REGULATORS						
V _I	Input voltage range for LDO1, 2		1.5		6.5	V
V _O	LDO1 output voltage range		1		3.3	V
V _O	LDO2 output voltage range		1		3.3	V
I _O	Maximum output current for LDO1, LDO2	V _I = 1.8 V, V _O = 1.3 V V _I = 1.5 V, V _O = 1.3 V	200	120		mA
I _(SC)	LDO1 and LDO2 short circuit current limit	V _(LDO1) = GND, V _(LDO2) = GND			400	mA
	Minimum voltage drop at LDO1, LDO2	I _O = 50 mA, VINLDO = 1.8 V I _O = 50 mA, VINLDO = 1.5 V I _O = 200 mA, VINLDO = 1.8 V		65	120 150 300	mV
	Output voltage accuracy for LDO1, LDO2	I _O = 10 mA	–2%		1%	
	Line regulation for LDO1, LDO2	VINLDO1,2 = VLDO1,2 + 0.5 V (min. 2.5 V) to 6.5 V, I _O = 10 mA	–1%		1%	
	Load regulation for LDO1, LDO2	I _O = 0 mA to 50 mA	–1%		1%	
	Regulation time for LDO1, LDO2	Load change from 10% to 90%		10		μs
ANALOGIC SIGNALS DEFDCDC1, DEFDCDC2, DEFDCDC3						
V _{IH}	High level input voltage		1.3		VCC	V
V _{IL}	Low level input voltage		0		0.1	V
	Input bias current			0.001	0.05	μA
THERMAL SHUTDOWN						
T _(SD)	Thermal shutdown	Increasing junction temperature		160		°C
	Thermal shutdown hysteresis	Decreasing junction temperature		20		°C
INTERNAL UNDERVOLTAGE LOCK OUT						
UVLO	Internal UVLO	VCC falling	–2%	2.35	2%	V
V _(UVLO_HYST)	Internal UVLO comparator hysteresis			120		mV
VOLTAGE DETECTOR COMPARATORS						
	Comparator threshold (PWRFAIL_SNS, LOWBAT_SNS)	Falling threshold	–1%	1	1%	V
	Hysteresis		40	50	60	mV
	Propagation delay	25 mV overdrive			10	μs
POWER GOOD						
V _(PGOODF)		VDCDC1, VDCDC2, VDCDC3, VLDO1, VLDO2, decreasing	–12%	–10%	–8%	
V _(PGOODR)		VDCDC1, VDCDC2, VDCDC3, VLDO1, VLDO2, increasing	–7%	–5%	–3%	

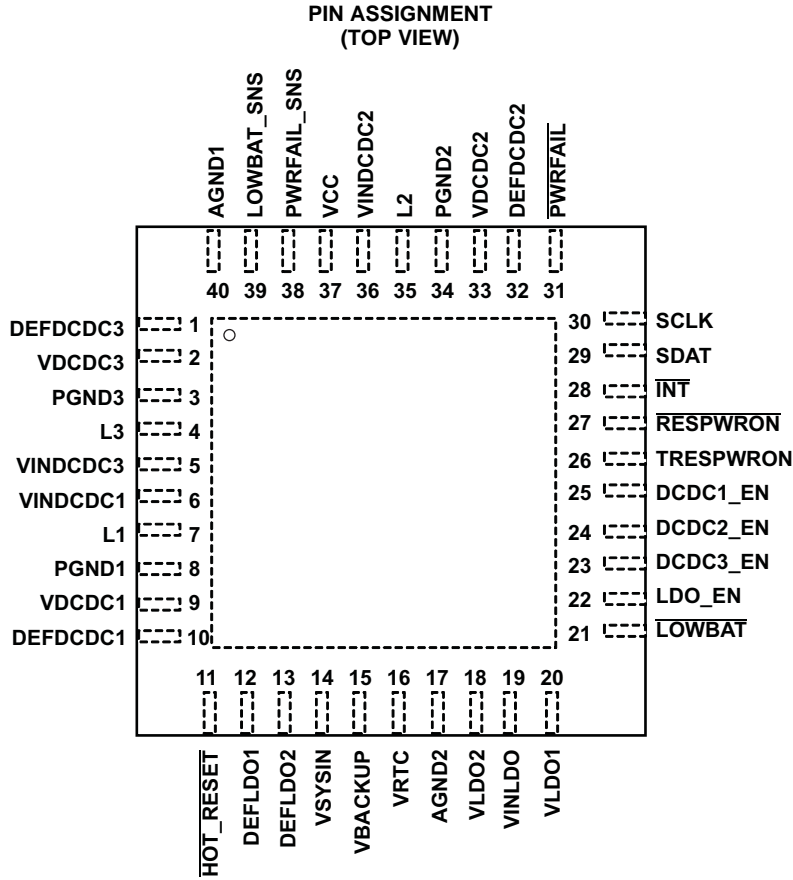

TERMINAL FUNCTIONS

TERMINAL NAME	NO.	I/O	DESCRIPTION
SWITCHING REGULATOR SECTION			
AGND1	40		Analog ground connection. All analog ground pins are connected internally on the chip.
AGND2	17		Analog ground connection. All analog ground pins are connected internally on the chip.
PowerPAD™	–		Connect the power pad to analog ground.
VINDCDC1	6	I	Input voltage for VDCDC1 step-down converter. This must be connected to the same voltage supply as VINDCDC2, VINDCDC3, and VCC.
L1	7		Switch pin of VDCDC1 converter. The VDCDC1 inductor is connected here.
VDCDC1	9	I	VDCDC1 feedback voltage sense input, connect directly to VDCDC1
PGND1	8		Power ground for VDCDC1 converter
VINDCDC2	36	I	Input voltage for VDCDC2 step-down converter. This must be connected to the same voltage supply as VINDCDC1, VINDCDC3, and VCC.
L2	35		Switch pin of VDCDC2 converter. The VDCDC2 inductor is connected here.
VDCDC2	33	I	VDCDC2 feedback voltage sense input, connect directly to VDCDC2
PGND2	34		Power ground for VDCDC2 converter
VINDCDC3	5	I	Input voltage for VDCDC3 step-down converter. This must be connected to the same voltage supply as VINDCDC1, VINDCDC2, and VCC.
L3	4		Switch pin of VDCDC3 converter. The VDCDC3 inductor is connected here.
VDCDC3	2	I	VDCDC3 feedback voltage sense input, connect directly to VDCDC3
PGND3	3		Power ground for VDCDC3 converter
VCC	37	I	Power supply for digital and analog circuitry of VDCDC1, VDCDC2, and VDCDC3 dc-dc converters. This must be connected to the same voltage supply as VINDCDC3, VINDCDC1, and VINDCDC2. Also supplies serial interface block

TERMINAL FUNCTIONS (continued)

TERMINAL		I/O	DESCRIPTION
NAME	NO.		
DEFDCDC1	10	I	Input signal indicating default VDCDC1 voltage, 0 = 3 V, 1 = 3.3 V. This pin can also be connected to a resistor divider between VDCDC1 and GND. If the output voltage of the DCDC1 converter is set in a range from 0.6 V to VINDCDC1 V.
DEFDCDC2	32	I	Input signal indicating default VDCDC2 voltage, 0 = 1.8 V, 1 = 2.5 V. This pin can also be connected to a resistor divider between VDCDC2 and GND. If the output voltage of the DCDC2 converter is set in a range from 0.6 V to VINDCDC2 V.
DEFDCDC3	1	I	Input signal indicating default VDCDC3 voltage, 0 = 1.3 V, 1 = 1.55 V. This pin can also be connected to a resistor divider between VDCDC3 and GND. If the output voltage of the DCDC3 converter is set in a range from 0.6 V to VINDCDC3 V.
DCDC1_EN	25	I	VDCDC1 enable pin. A logic high enables the regulator, a logic low disables the regulator.
DCDC2_EN	24	I	VDCDC2 enable pin. A logic high enables the regulator, a logic low disables the regulator.
DCDC3_EN	23	I	VDCDC3 enable pin. A logic high enables the regulator, a logic low disables the regulator.
LDO REGULATOR SECTION			
VINLDO	19	I	I Input voltage for LDO1 and LDO2
VLDO1	20	O	Output voltage of LDO1
VLDO2	18	O	Output voltage of LDO2
LDO_EN	22	I	Enable input for LDO1 and LDO2. Logic high enables the LDOs, logic low disables the LDOs
VBACKUP	15	I	Connect the backup battery to this input pin.
VRTC	16	O	Output voltage of the LDO/switch for the real time clock
VSYSIN	14	I	Input of system voltage for VRTC switch
DEFLD01	12	I	Digital input, used to set default output voltage of LDO1 and LDO2
DEFLD02	13	I	Digital input, used to set default output voltage of LDO1 and LDO2
CONTROL AND I²C SECTION			
HOT_RESET	11	I	Push button input used to reboot or wake-up processor via $\overline{\text{RESPWRON}}$ output pin
TRESPWRON	26	I	Connect the timing capacitor to this pin to set the reset delay time: 1 nF → 100 ms
$\overline{\text{RESPWRON}}$	27	O	Open drain System reset output
$\overline{\text{PWRFAIL}}$	31	O	Open drain output. Active low when $\overline{\text{PWRFAIL}}$ comparator indicates low VBAT condition.
$\overline{\text{LOW_BAT}}$	21	O	Open drain output of LOW_BAT comparator
INT	28	O	Open drain output
SCLK	30	I	Serial interface clock line
SDAT	29	I/O	Serial interface data/address
PWRFAIL_SNS	38	I	Input for the comparator driving the $\overline{\text{PWRFAIL}}$ output.
LOWBAT_SNS	39	I	Input for the comparator driving the $\overline{\text{LOW_BAT}}$ output.

FUNCTIONAL BLOCK DIAGRAM

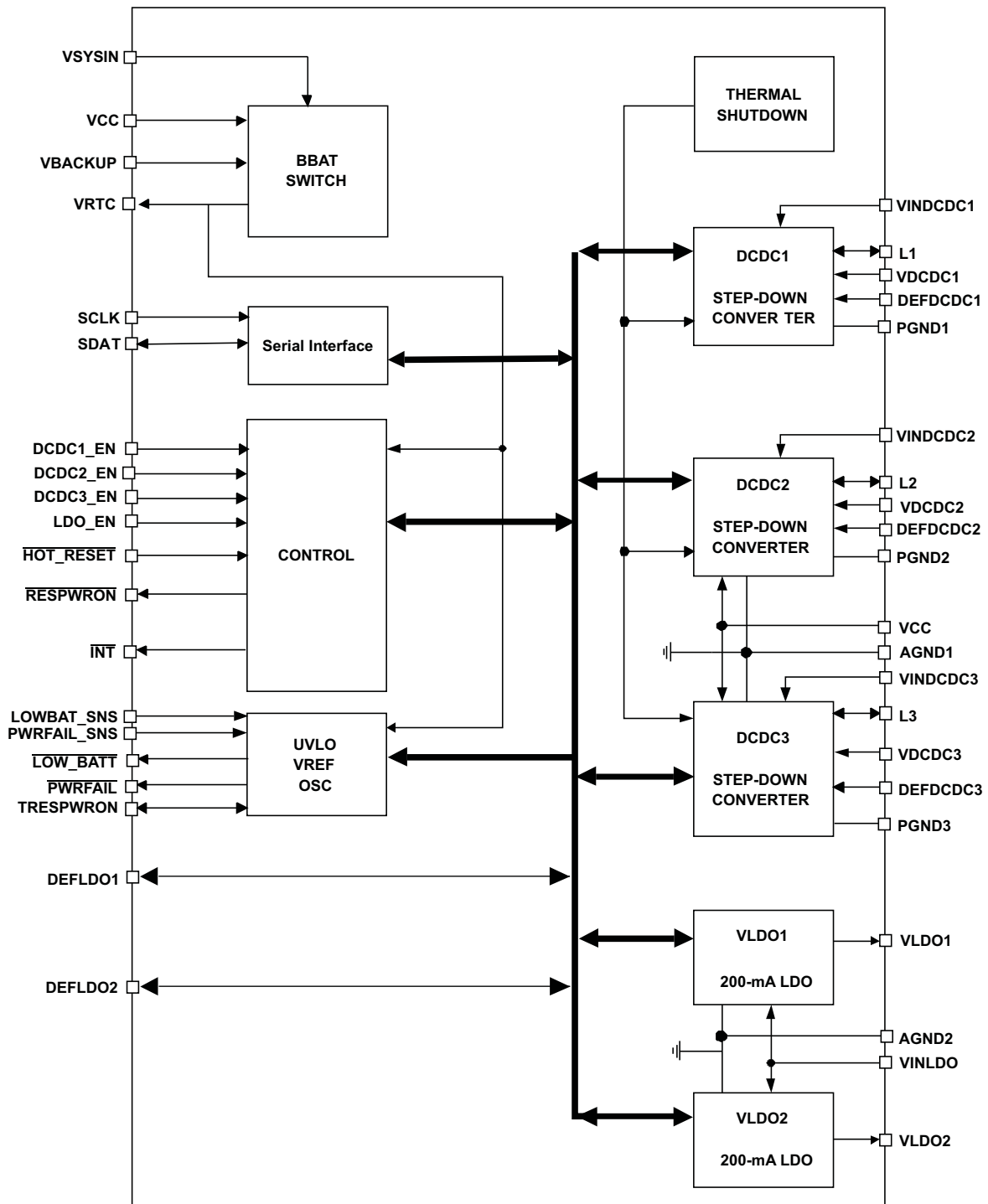

TYPICAL CHARACTERISTICS

Graphs were taken using the EVM with the following inductor/output capacitor combinations:

CONVERTER	INDUCTOR	OUTPUT CAPACITOR	OUTPUT CAPACITOR VALUE
VDCDC1	VLCF4020-2R2	C2012X5R0J106M	$2 \times 10 \mu\text{F}$
VDCDC2	VLCF4020-2R2	C2012X5R0J106M	$2 \times 10 \mu\text{F}$
VDCDC3	VLF4012AT-2R2M1R5	C2012X5R0J106M	$2 \times 10 \mu\text{F}$

Table 1. Table of Graphs

		FIGURE
η	Efficiency	1, 2, 3, 4, 5, 6, 7
	Line transient response	8, 9, 10
	Load transient response	11, 12, 13
	VDCDC2 PFM operation	14
	VDCDC2 low ripple PFM operation	15
	VDCDC2 PWM operation	16
	Startup VDCDC1, VDCDC2 and VDCDC3	17
	Startup LDO1 and LDO2	18
	Line transient response	19, 20, 21
	Load transient response	22, 23, 24

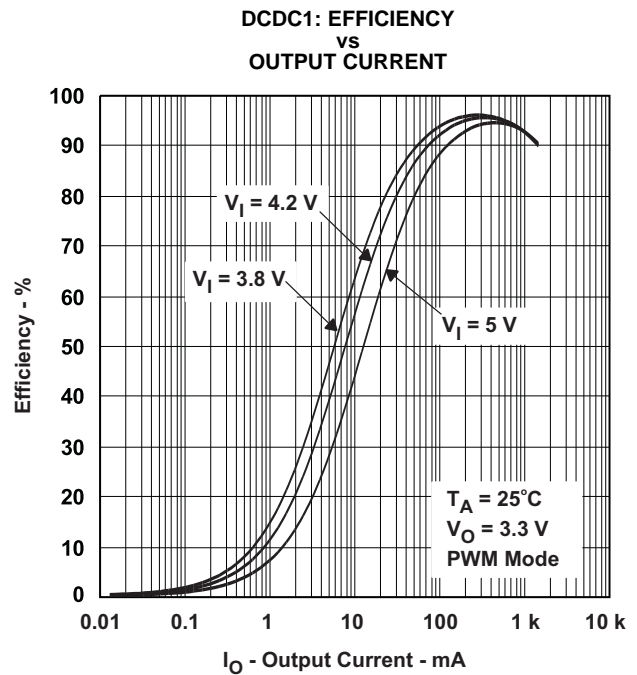
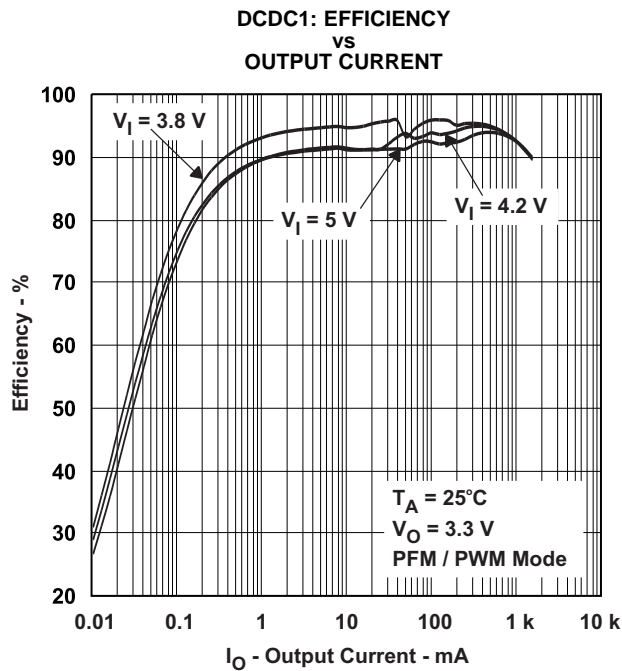

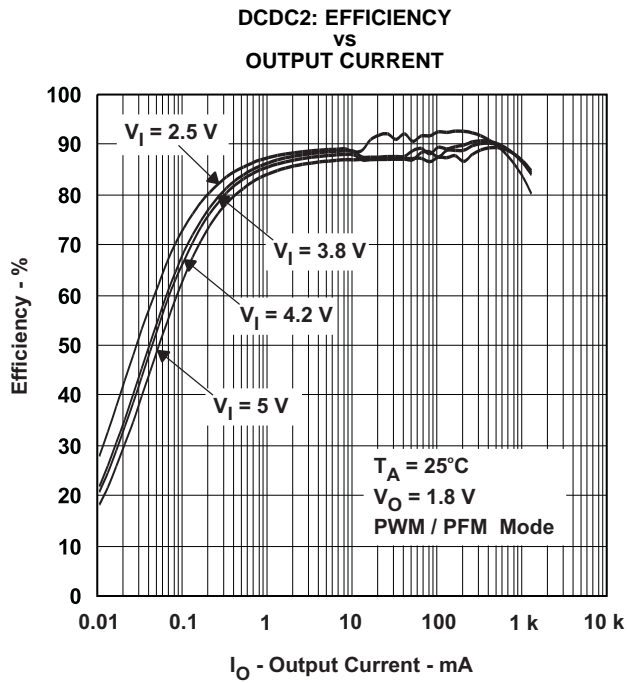

Figure 3.

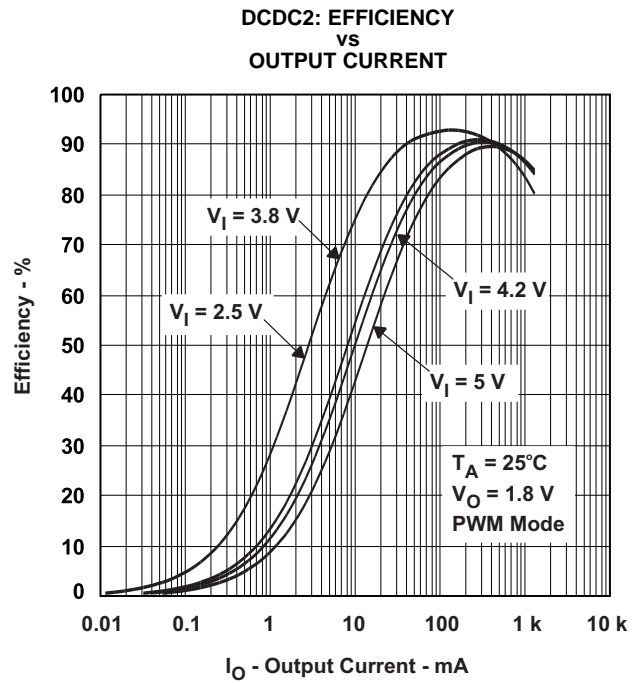

Figure 4.

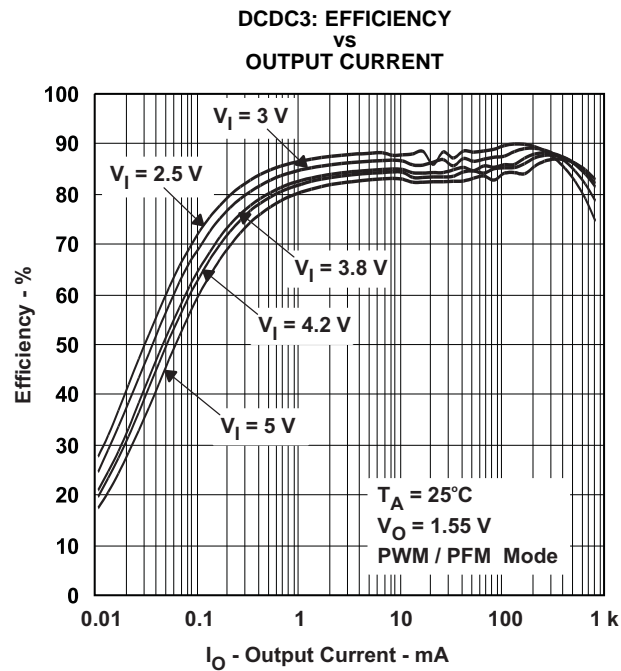

Figure 5.

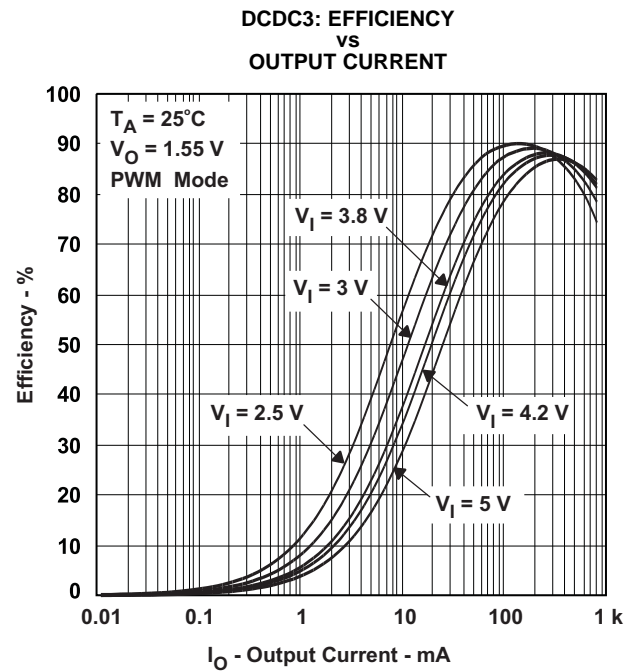

Figure 6.

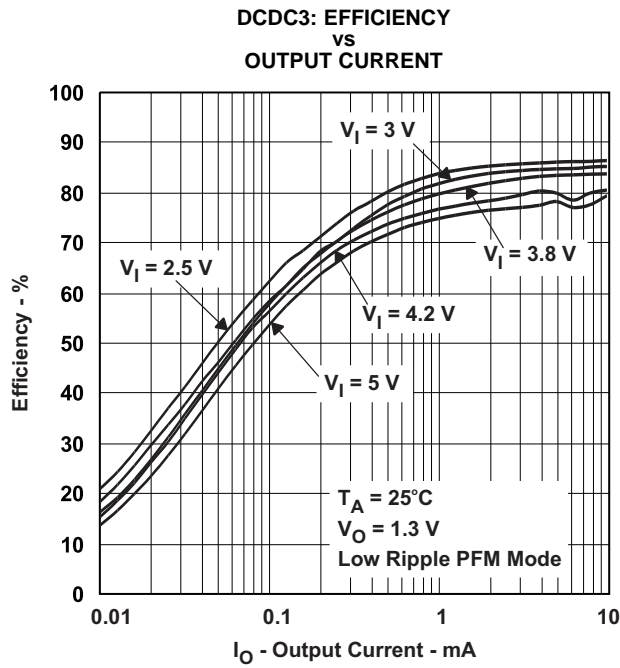

Figure 7.

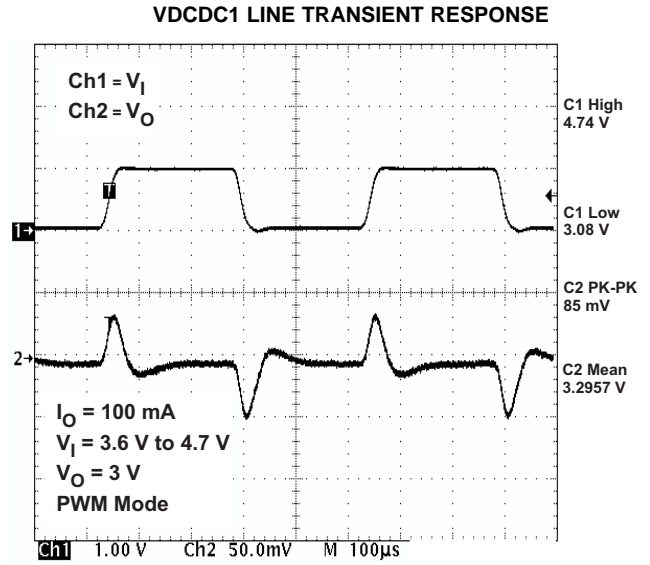

Figure 8.

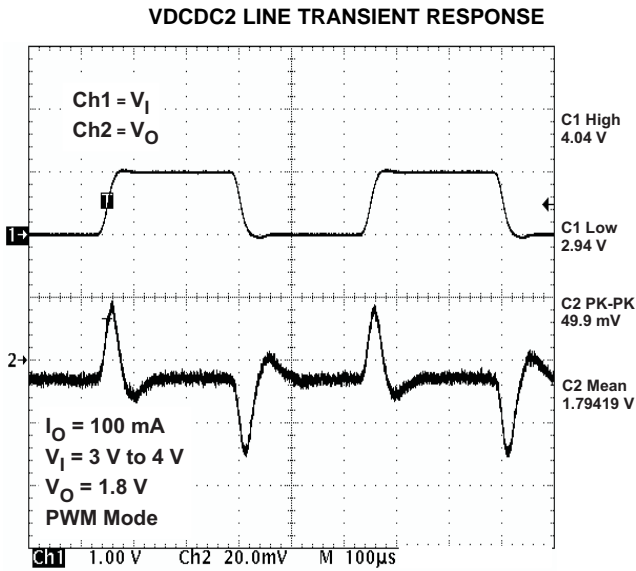

Figure 9.

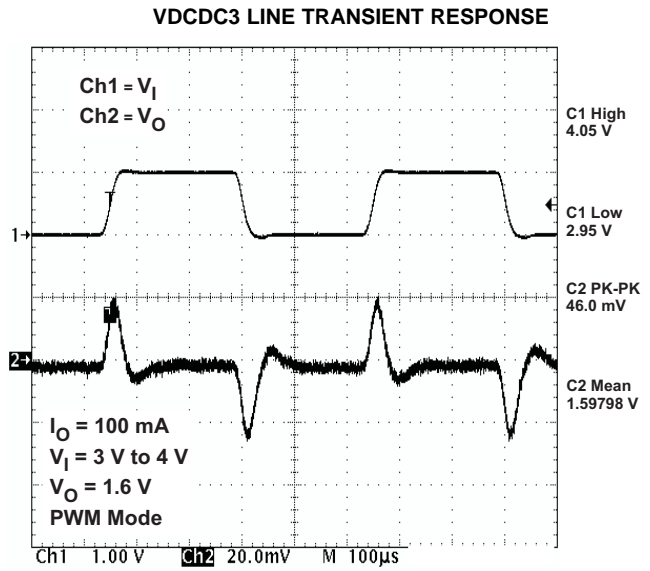

Figure 10.

VDCDC1 LOAD TRANSIENT RESPONSE

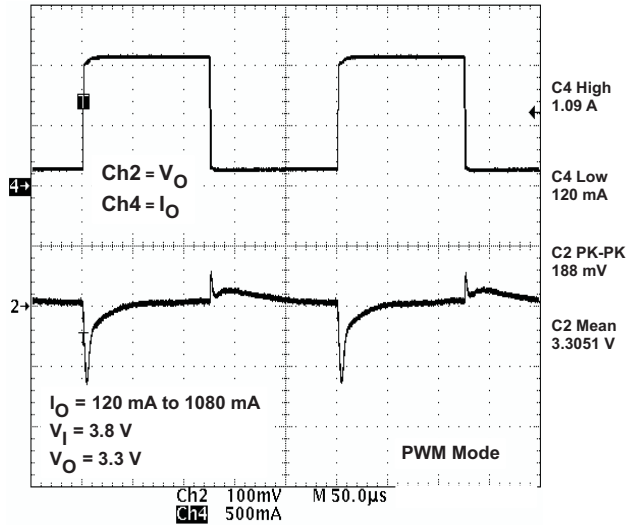

Figure 11.

VDCDC2 LOAD TRANSIENT RESPONSE

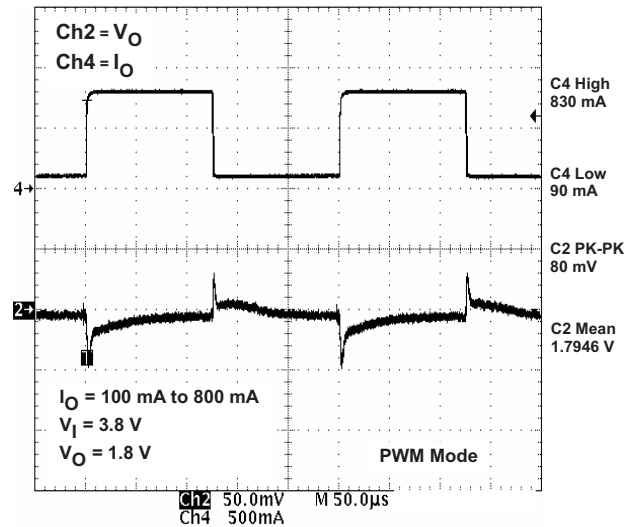

Figure 12.

VDCDC3 LOAD TRANSIENT RESPONSE

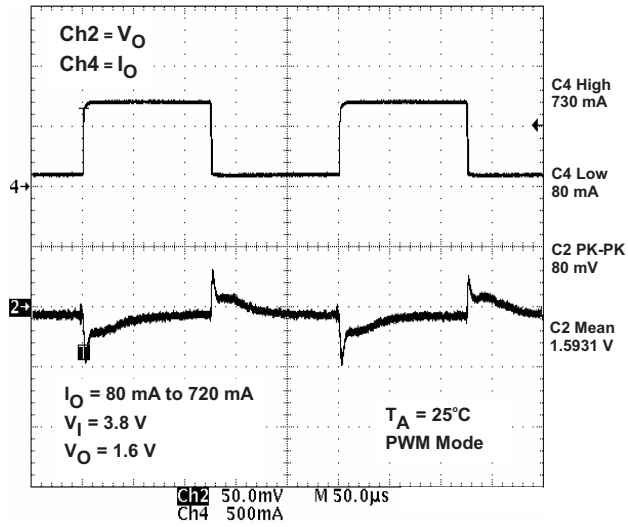

Figure 13.

VDCDC2 OUTPUT VOLTAGE RIPPLE

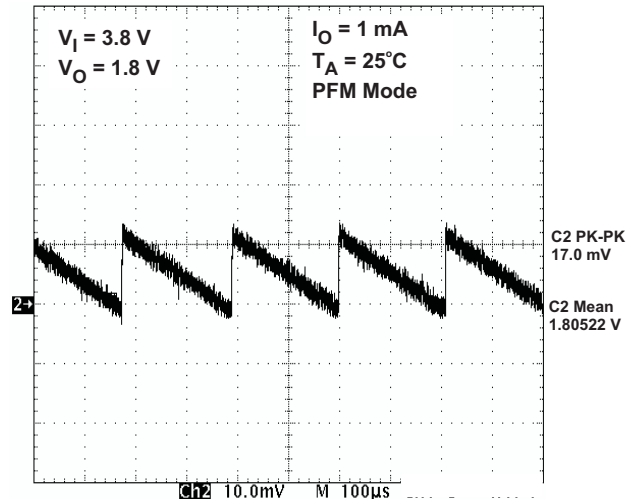

Figure 14.

VDCDC2 OUTPUT VOLTAGE RIPPLE

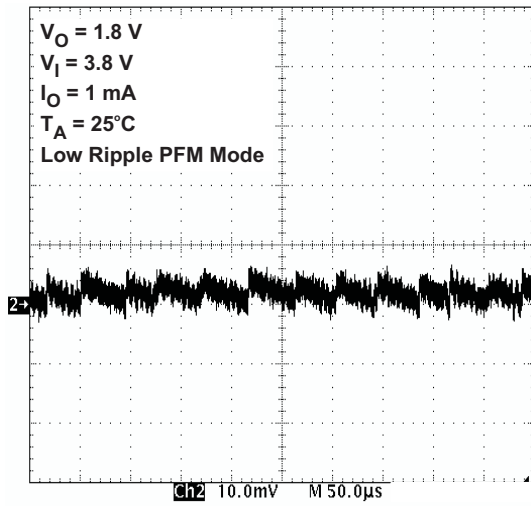

Figure 15.

VDCDC2 OUTPUT VOLTAGE RIPPLE

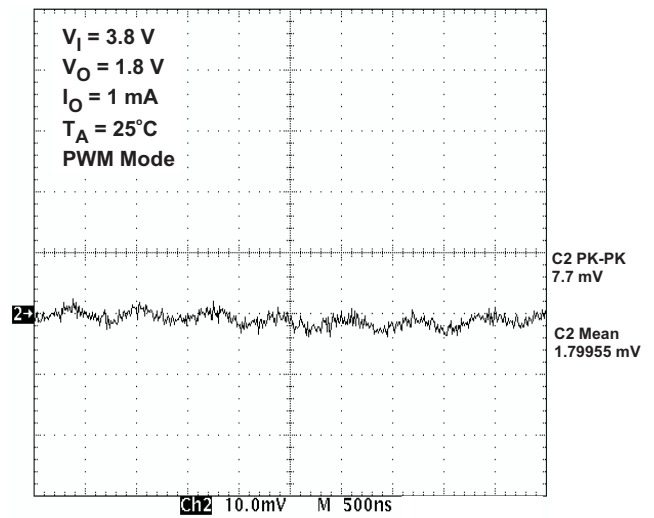

Figure 16.

STARTUP VDCDC1, VDCDC2, AND VDCDC3

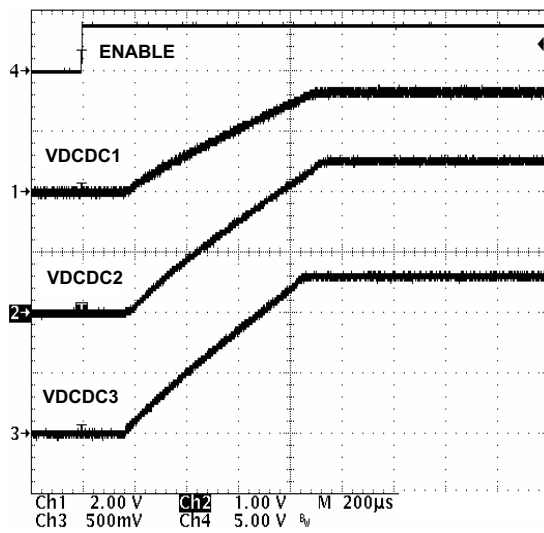

Figure 17.

STARTUP LDO1 AND LDO2

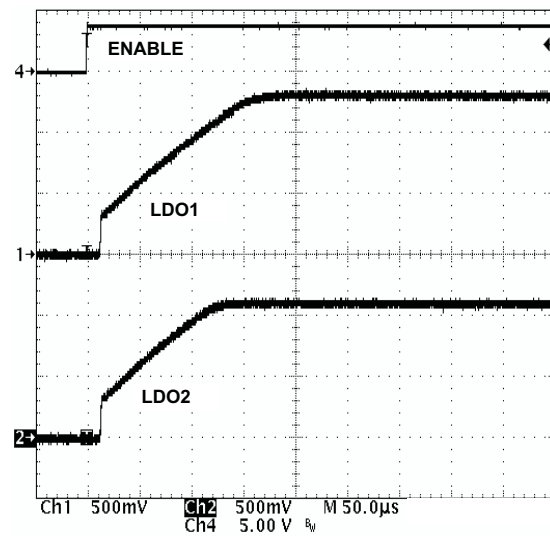

Figure 18.

LDO1 LINE TRANSIENT RESPONSE

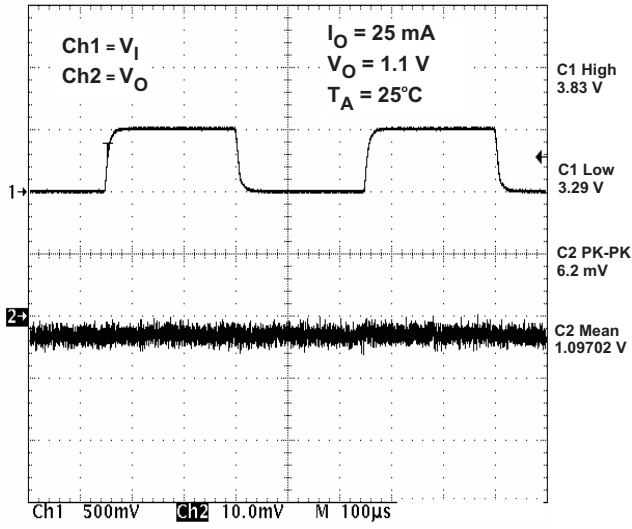

Figure 19.

LDO2 LINE TRANSIENT RESPONSE

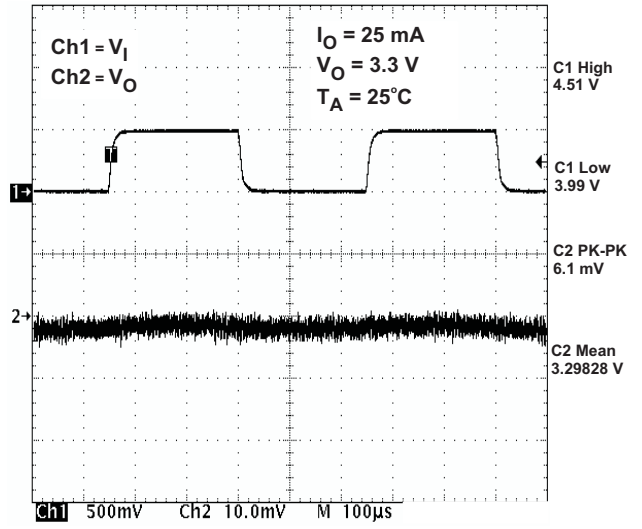

Figure 20.

VRTC LINE TRANSIENT RESPONSE

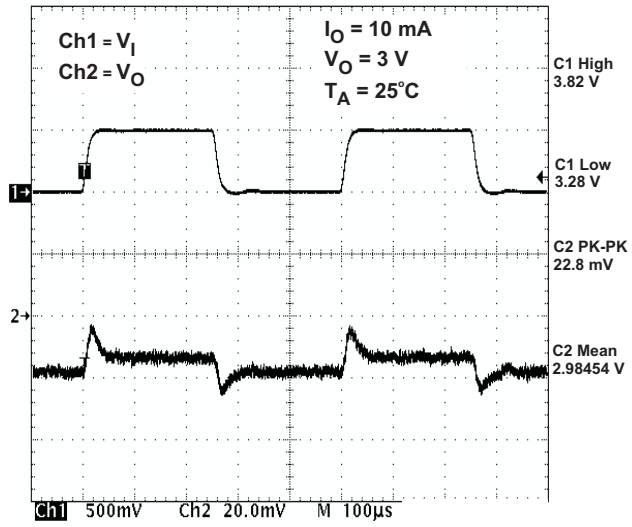

Figure 21.

LDO1 LOAD TRANSIENT RESPONSE

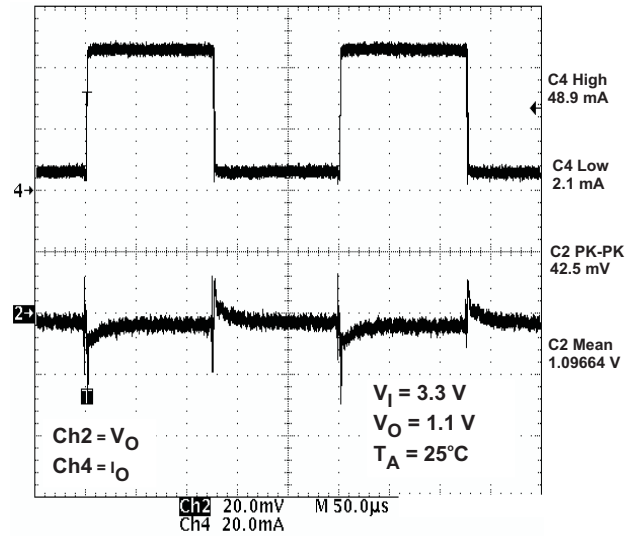

Figure 22.

LDO2 LOAD TRANSIENT RESPONSE

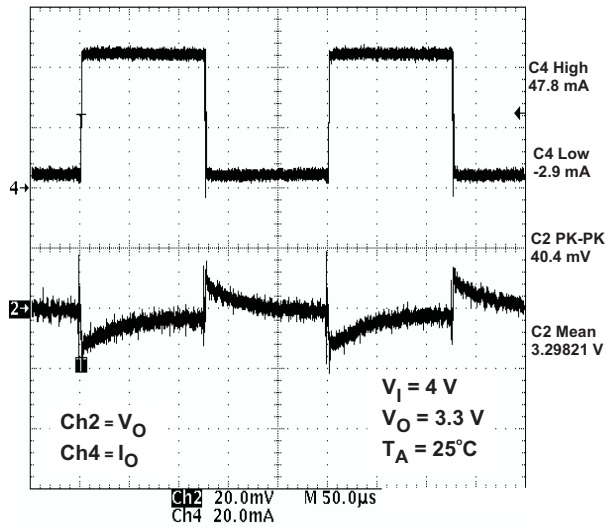

Figure 23.

VRTC LOAD TRANSIENT RESPONSE

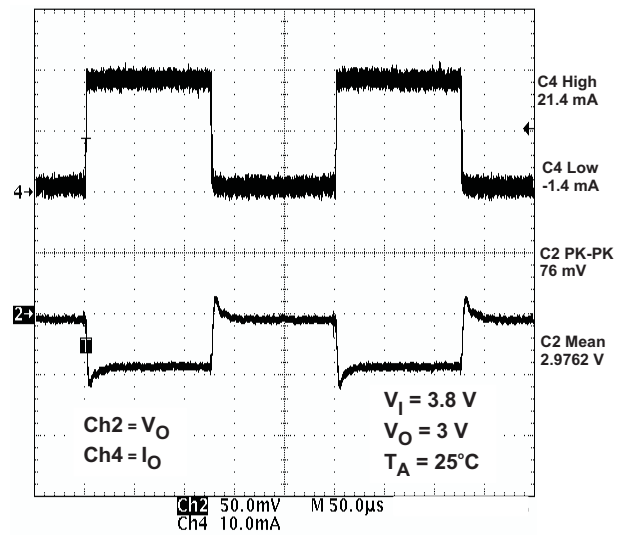

Figure 24.

DETAILED DESCRIPTION

VRTC OUTPUT AND OPERATION WITH OR WITHOUT BACKUP BATTERY

The VRTC pin is an always-on output, intended to supply up to 30 mA to a permanently required rail. This is the VCC_BATT rail of the Intel® PXA270 Bulverde processor for example.

In applications using a backup battery, the backup voltage can be either directly connected to the TPS65022 VBACKUP pin if a Li-Ion cell is used, or via a boost converter (e.g. TPS61070) if a single NiMH battery is used. The voltage applied to the VBACKUP pin is fed through a PMOS switch to the VRTC pin. The TPS65022 asserts the $\overline{\text{RESPWRON}}$ signal if VRTC drops below 2.4 V. This, together with 375 mV at 30 mA drop out for the PMOS switch means that the voltage applied at VBACKUP must be greater than 2.775 V for normal system operation.

When the voltage at the VSYSIN pin exceeds 2.65 V, the path from VBACKUP to VRTC is cut, and VRTC is supplied by a similar PMOS switch from the voltage source connected to the VSYSIN input. Typically this is the VDCC1 converter but can be any voltage source within the appropriate range.

In systems where no backup battery is used, the VBACKUP pin is connected to GND. In this case, a low power LDO is enabled, supplied from VCC and capable of delivering 30 mA to the 3 V output. This LDO is disabled if the voltage at the VSYSIN input exceeds 2.65 V. VRTC is then supplied from the external source connected to this pin as previously described.

Inside TPS65022 there is a switch (Vmax switch) which selects the higher voltage between VCC and VBACKUP. This is used as the supply voltage for some basic functions. The functions powered from the output of the Vmax switch are:

- $\overline{\text{INT}}$ output
- $\overline{\text{RESPWRON}}$ output
- $\overline{\text{HOT_RESET}}$ input
- $\overline{\text{LOW_BATT}}$ output
- $\overline{\text{PWRFAIL}}$ output
- Enable pins for dc-dc converters, LDO1 and LDO2
- Undervoltage lockout comparator (UVLO)
- Reference system with low frequency timing oscillators
- $\overline{\text{LOW_BATT}}$ and $\overline{\text{PWRFAIL}}$ comparators

The main 1.5-MHz oscillator, and the I²C™ interface are only powered from V_{CC}.

DETAILED DESCRIPTION (continued)

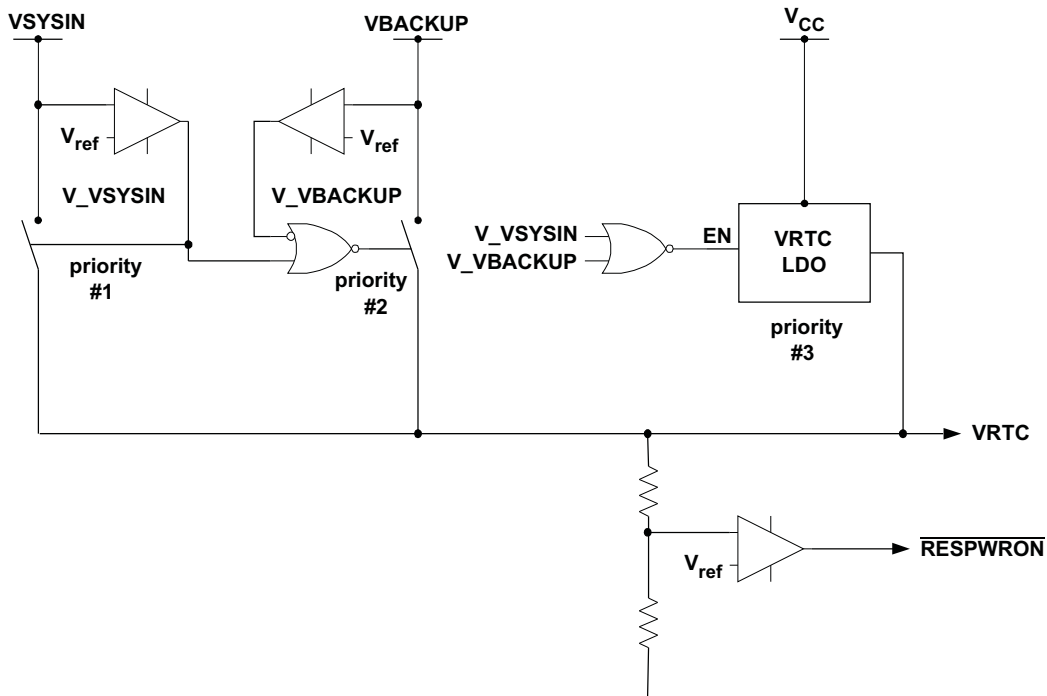

- A. V_VSYSIN, V_VBACKUP thresholds: falling = 2.55 V, rising = 2.65 V \pm 3%
- B. $\overline{\text{RESPWRON}}$ thresholds: falling = 2.4 V, rising = 2.52 V \pm 3%

Figure 25.

STEP-DOWN CONVERTERS, VDCDC1, VDCDC2, and VDCDC3

The TPS65022 incorporates three synchronous step-down converters operating typically at 1.5 MHz fixed frequency pulse width modulation (PWM) at moderate to heavy load currents. At light load currents, the converters automatically enter the power save mode (PSM), and operate with pulse frequency modulation (PFM). The VDCDC1 converter is capable of delivering 1.2 A output current, the VDCDC2 converter is capable of delivering 1 A and the VDCDC3 converter is capable of delivering up to 900 mA.

The converter output voltages can be programmed via the DEFDCDC1, DEFDCDC2 and DEFDCDC3 pins. The pins can either be connected to GND, VCC, or to a resistor divider between the output voltage and GND. The VDCDC1 converter defaults to 3 V or 3.3 V depending on the DEFDCDC1 configuration pin. If DEFDCDC1 is tied to ground, the default is 3 V. If it is tied to VCC, the default is 3.3 V. When the DEFDCDC1 pin is connected to a resistor divider, the output voltage can be set in the range of 0.6 V to VINDCDC1 V. See the application information section for more details.

The VDCDC2 converter defaults to 1.8 V or 2.5 V depending on the DEFDCDC2 configuration pin. If DEFDCDC2 is tied to ground, the default is 1.8 V. If it is tied to VCC, the default is 2.5 V. When the DEFDCDC2 pin is connected to a resistor divider, the output voltage can be set in the range of 0.6 V to VINDCDC2 V.

The VDCDC3 converter defaults to 1.3 V or 1.55 V depending on the DEFDCDC3 configuration pin. If DEFDCDC3 is tied to ground the default is 1.3 V. If it is tied to VCC, the default is 1.55 V. When the DEFDCDC3 pin is connected to a resistor divider, the output voltage can be set in the range of 0.6 V to VINDCDC3 V. The core voltage can be reprogrammed via the serial interface in the range of 0.8 V to 1.6 V with a programmable slew rate. The converter is forced into PWM operation whilst any programmed voltage change is underway, whether the voltage is being increased or decreased. The DEFDCDC3 pin is connected to a resistor divider, the output voltage can be set in the range of 0.6 V to VINDCDC3 V. The core voltage can be reprogrammed via the serial interface in the range of 0.8 V to 1.6 V with a programmable slew rate. The converter is forced into PWM operation whilst any programmed voltage change is underway, whether the voltage is being increased or decreased. The DEFDCDC3 pin is connected to a resistor divider, the output voltage can be set in the range of 0.6 V to VINDCDC3 V. The core voltage can be reprogrammed via the serial interface in the range of 0.8 V to 1.6 V with a programmable slew rate. The converter is forced into PWM operation whilst any programmed voltage change is underway, whether the voltage is being increased or decreased. The DEFDCDC3 pin is connected to a resistor divider, the output voltage can be set in the range of 0.6 V to VINDCDC3 V.

The step-down converter outputs (when enabled) are monitored by power good (PG) comparators, the outputs of which are available via the serial interface. The outputs of the dc-dc converters can be optionally discharged via on-chip 300-Ω resistors when the dc-dc converters are disabled.

DETAILED DESCRIPTION (continued)

During PWM operation, the converters use a unique fast response voltage mode controller scheme with input voltage feed-forward to achieve good line and load regulation allowing the use of small ceramic input and output capacitors. At the beginning of each clock cycle initiated by the clock signal, the P-channel MOSFET switch is turned on. The inductor current ramps up until the comparator trips and the control logic turns off the switch. The current limit comparator also turns off the switch if the current limit of the P-channel switch is exceeded. After the adaptive dead time used to prevent shoot through current, the N-channel MOSFET rectifier is turned on, and the inductor current ramps down. The next cycle is initiated by the clock signal, again turning off the N-channel rectifier and turning on the P-channel switch.

The three dc-dc converters operate synchronized to each other with the VDCDC1 converter as the master. A 180° phase shift between the VDCDC1 switch turn on and the VDCDC2 and a further 90° shift to the VDCDC3 switch turn on decreases the input RMS current and smaller input capacitors can be used. This is optimized for a typical application where the VDCDC1 converter regulates a Li-Ion battery voltage of 3.7 V to 3.3 V, the VDCDC2 converter from 3.7 V to 2.5 V, and the VDCDC3 converter from 3.7 V to 1.5 V. The phase of the three converters can be changed using the CON_CTRL register.

POWER SAVE MODE OPERATION

As the load current decreases, the converters enter the power save mode operation. During PSM, the converters operate in a burst mode (PFM mode) with a frequency between 750 kHz and 1.5 MHz, nominal for one burst cycle. However, the frequency between different burst cycles depends on the actual load current and is typically far less than the switching frequency with a minimum quiescent current to maintain high efficiency.

In order to optimize the converter efficiency at light load, the average current is monitored and if in PWM mode the inductor current remains below a certain threshold, then PSM is entered. The typical threshold to enter PSM is calculated as follows:

$$I_{\text{PFMDCDC1 enter}} = \frac{V_{\text{INDCDC1}}}{24 \Omega}$$

$$I_{\text{PFMDCDC2 enter}} = \frac{V_{\text{INDCDC2}}}{26 \Omega}$$

$$I_{\text{PFMDCDC3 enter}} = \frac{V_{\text{INDCDC3}}}{39 \Omega} \quad (1)$$

During the PSM the output voltage is monitored with a comparator, and by maximum skip burst width. As the output voltage falls below the threshold, set to the nominal V_O , the P-channel switch turns on and the converter effectively delivers a constant current defined as follows.

$$I_{\text{PFMDCDC1 leave}} = \frac{V_{\text{INDCDC1}}}{18 \Omega}$$

$$I_{\text{PFMDCDC2 leave}} = \frac{V_{\text{INDCDC2}}}{20 \Omega}$$

$$I_{\text{PFMDCDC3 leave}} = \frac{V_{\text{INDCDC3}}}{29 \Omega} \quad (2)$$

If the load is below the delivered current then the output voltage rises until the same threshold is crossed in the other direction. All switching activity ceases, reducing the quiescent current to a minimum until the output voltage has again dropped below the threshold. The power save mode is exited, and the converter returns to PWM mode if either of the following conditions are met:

1. the output voltage drops 2% below the nominal V_O due to increasing load current
2. the PFM burst time exceeds $16 \times 1/f_s$ (10.67 μs typical).

DETAILED DESCRIPTION (continued)

These control methods reduce the quiescent current to typically 14 μA per converter, and the switching activity to a minimum, thus achieving the highest converter efficiency. Setting the comparator thresholds at the nominal output voltage at light load current results in a low output voltage ripple. The ripple depends on the comparator delay and the size of the output capacitor. Increasing capacitor values makes the output ripple tend to zero. The PSM is disabled through the I²C interface to force the individual converters to stay in fixed frequency PWM mode.

LOW RIPPLE MODE

Setting Bit 3 in register CON-CTRL to 1 enables the low ripple mode for all of the dc-dc converters if operated in PFM mode. For an output current less than approximately 10 mA, the output voltage ripple in PFM mode is reduced, depending on the actual load current. The lower the actual output current on the converter, the lower the output ripple voltage. For an output current above 10 mA, there is only minor difference in output voltage ripple between PFM mode and low ripple PFM mode. As this feature also increases switching frequency, it is used to keep the switching frequency above the audible range in PFM mode down to a low output current.

SOFT START

Each of the three converters has an internal soft start circuit that limits the inrush current during start-up. The soft start is realized by using a very low current to initially charge the internal compensation capacitor. The soft start time is typically 750 μs if the output voltage ramps from 5% to 95% of the final target value. If the output is already precharged to some voltage when the converter is enabled, then this time is reduced proportionally. There is a short delay of typically 170 μs between the converter being enabled and switching activity actually starting. This is to allow the converter to bias itself properly, to recognize if the output is precharged, and if so to prevent discharging of the output while the internal soft start ramp catches up with the output voltage.

100% DUTY CYCLE LOW DROPOUT OPERATION

The TPS65022 converters offer a low input to output voltage difference while still maintaining operation with the use of the 100% duty cycle mode. In this mode the P-channel switch is constantly turned on. This is particularly useful in battery-powered applications to achieve longest operation time by taking full advantage of the whole battery voltage range. The minimum input voltage required to maintain dc regulation depends on the load current and output voltage. It is calculated as:

$$V_{in_min} = V_{out_min} + I_{out_max} \times (r_{DS(on)_max} + R_L) \quad (3)$$

with:

I_{out_max} = maximum load current (Note: ripple current in the inductor is zero under these conditions)

$r_{DS(on)_max}$ = maximum P-channel switch $r_{DS(on)}$

R_L = DC resistance of the inductor

V_{out_min} = nominal output voltage minus 2% tolerance limit

ACTIVE DISCHARGE WHEN DISABLED

When the VDCDC1, VDCDC2, and VDCDC3 converters are disabled, due to an UVLO, DCDC_EN or OVERTEMP condition, it is possible to actively pull down the outputs. This feature is disabled per default and is individually enabled via the CON_CTRL2 register in the serial interface. When this feature is enabled, the VDCDC1, VDCDC2, and VDCDC3 outputs are discharged by a 300 Ω (typical) load which is active as long as the converters are disabled.

POWER GOOD MONITORING

All three step-down converters and both the LDO1 and LDO2 linear regulators have power good comparators. Each comparator indicates when the relevant output voltage has dropped 10% below its target value with 5% hysteresis. The outputs of these comparators are available in the PGOODZ register via the serial interface. An interrupt is generated when any voltage rail drops below the 10% threshold. The comparators are disabled when the converters are disabled and the relevant PGOODZ register bits indicate that power is good.

DETAILED DESCRIPTION (continued)

LOW DROPOUT VOLTAGE REGULATORS

The low dropout voltage regulators are designed to operate well with low value ceramic input and output capacitors. They operate with input voltages down to 1.5 V. The LDOs offer a maximum dropout voltage of 300 mV at rated output current. Each LDO supports a current limit feature. Both LDOs are enabled by the LDO_EN pin, both LDOs can be disabled or programmed via the serial interface using the REG_CTRL and LDO_CTRL registers. The LDOs also have reverse conduction prevention. This allows the possibility to connect external regulators in parallel in systems with a backup battery. The TPS65022 step-down and LDO voltage regulators automatically power down when the V_{CC} voltage drops below the UVLO threshold or when the junction temperature rises above 160°C.

POWER GOOD MONITORING

Both the LDO1 and LDO2 linear regulators have power good comparators. Each comparator indicates when the relevant output voltage has dropped 10% below its target value, with 5% hysteresis. The outputs of these comparators are available in the PGOODZ register via the serial interface. An interrupt is generated when any voltage rail drops below the 10% threshold. The comparators are disabled when the LDOs are disabled and the relevant PGOODZ register bits indicate that power is good.

UNDERVOLTAGE LOCKOUT

The undervoltage lockout circuit for the five regulators on the TPS65022 prevents the device from malfunctioning at low-input voltages and from excessive discharge of the battery. It disables the converters and LDOs. The UVLO circuit monitors the VCC pin, the threshold is set internally to 2.35 V with 5% (120 mV) hysteresis. Note that when any of the dc-dc converters are running, there is an input current at the VCC pin, which is up to 3 mA when all three converters are running in PWM mode. This current needs to be taken into consideration if an external RC filter is used at the VCC pin to remove switching noise from the TPS65022 internal analog circuitry supply.

POWER-UP SEQUENCING

The TPS65022 power-up sequencing is designed to be entirely flexible and customer driven. This is achieved by providing separate enable pins for each switch-mode converter, and a common enable signal for the LDOs. The relevant control pins are described in [Table 2](#).

Table 2. Control Pins and Status Outputs for DC-DC Converters

PIN NAME	INPUT OUTPUT	FUNCTION
DEFDCDC3	I	Defines the default voltage of the VDCDC3 switching converter. DEFDCDC3 = 0 defaults VDCDC3 to 1.3 V, DEFDCDC3 = VCC defaults VDCDC3 to 1.55 V.
DEFDCDC2	I	Defines the default voltage of the VDCDC2 switching converter. DEFDCDC2 = 0 defaults VDCDC2 to 1.8 V, DEFDCDC2 = VCC defaults VDCDC2 to 2.5 V.
DEFDCDC1	I	Defines the default voltage of the VDCDC1 switching converter. DEFDCDC1 = 0 defaults VDCDC1 to 3 V, DEFDCDC1 = VCC defaults VDCDC1 to 3.3 V.
DCDC3_EN	I	Set DCDC3_EN = 0 to disable and DCDC3_EN = 1 to enable the VDCDC3 converter
DCDC2_EN	I	Set DCDC2_EN = 0 to disable and DCDC2_EN = 1 to enable the VDCDC2 converter
DCDC1_EN	I	Set DCDC1_EN = 0 to disable and DCDC1_EN = 1 to enable the VDCDC1 converter
HOT_RESET	I	The HOT_RESET pin generates a reset (RESPWRON) for the processor. HOT_RESET does not alter any TPS65022 settings except the output voltage of VDCDC3. Activating HOT_RESET sets the voltage of VDCDC3 to its default value defined with the DEFDCDC3 pin. HOT_RESET is internally de-bounced by the TPS65022.
RESPWRON	O	RESPWRON is held low when power is initially applied to the TPS65022. The VRTC voltage is monitored: RESPWRON is low when VRTC < 2.4 V and remains low for a time defined by the external capacitor at the TRESPWRON pin. RESPWRON can also be forced low by activation of the HOT_RESET pin.
TRESPWRON	I	Connect a capacitor here to define the RESET time at the RESPWRON pin. 1 nF typically gives 100 ms.

SYSTEM RESET + CONTROL SIGNALS

The $\overline{\text{RESPWRON}}$ signal can be used as a global reset for the application. It is an open drain output. The $\overline{\text{RESPWRON}}$ signal is generated according to the power good comparator of VRTC, and remains low for t_{respwron} seconds after VRTC has risen above 2.52 V (falling threshold is 2.4 V, 5% hysteresis). t_{respwron} is set by an external capacitor at the TRESPWRON pin. 1 nF gives typically 100 ms. $\overline{\text{RESPWRON}}$ is also triggered by the HOT_RESET input. This input is internally debounced, with a filter time of typically 30 ms.

The $\overline{\text{PWRFAIL}}$ and $\overline{\text{LOW_BAT}}$ signals are generated by two voltage detectors using the PWRFAIL_SNS and LOWBAT_SNS input signals. Each input signal is compared to a 1 V threshold (falling edge) with 5% (50 mV) hysteresis.

The DCDC3 converter is reset to its default output voltage defined by the DEFDCDC3 input, when $\overline{\text{HOT_RESET}}$ is asserted. Other I²C registers are not affected. Generally, the DCDC3 converter is set to its default voltage with one of these conditions: $\overline{\text{HOT_RESET}}$ active, VRTC lower than its threshold voltage, undervoltage lockout (UVLO) condition, $\overline{\text{RESPWRON}}$ active, both DCDC3-converter AND DCDC1-converter disabled. In addition, the voltage of VDCDC3 changes to 1xxx0, if the VDCDC1 converter is disabled. Where xxx is the state before VDCDC1 was disabled.

DEFLDO1 and DEFLDO2

These two pins are used to set the default output voltage of the two 200 mA LDOs. The digital value applied to the pins is latched during power up and determines the initial output voltage according to Table 3. The voltage of both LDOs can be changed during operation with the I²C interface as described in the interface description.

Table 3.

DEFLDO2	DEFLDO1	VLDO1	VLDO2
0	0	1.1 V	1.3 V
0	1	1.5 V	1.3 V
1	0	2.6 V	2.8 V
1	1	3.15 V	3.3 V

Interrupt Management and the $\overline{\text{INT}}$ Pin

The $\overline{\text{INT}}$ pin combines the outputs of the PGOOD comparators from each dc-dc converter and LDOs. The $\overline{\text{INT}}$ pin is used as a POWER_OK pin indicating when all enabled supplies are in regulation. If the PGOODZ register is read via the serial interface, any active bits are then blocked from the $\overline{\text{INT}}$ output pin.

Interrupts can be masked using the MASK register; default operation is not to mask any DCDC or LDO interrupts since this provides the POWER_OK function.

TIMING DIAGRAMS

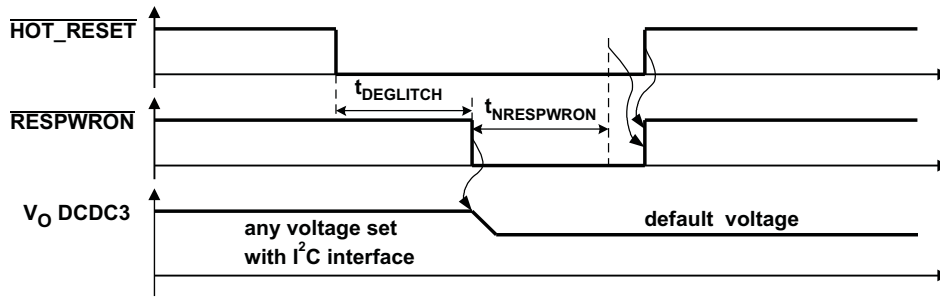

Figure 26. HOT_RESET Timing

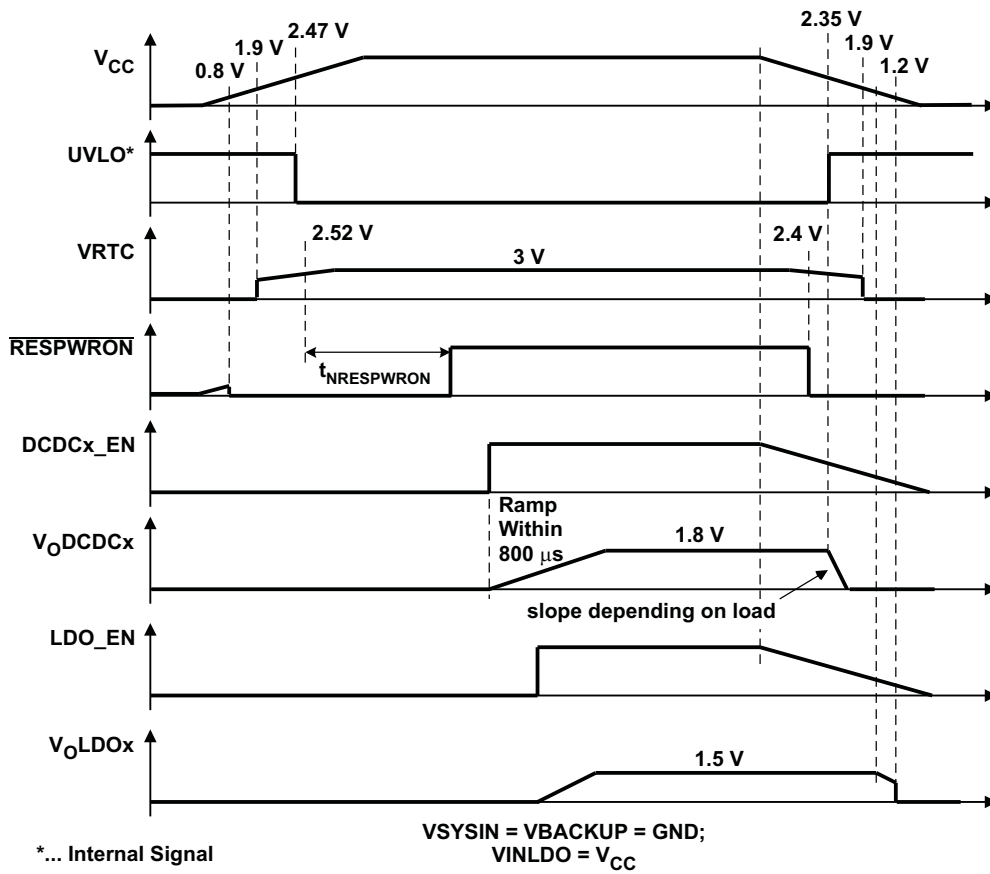

Figure 27. Power-Up and Power-Down Timing

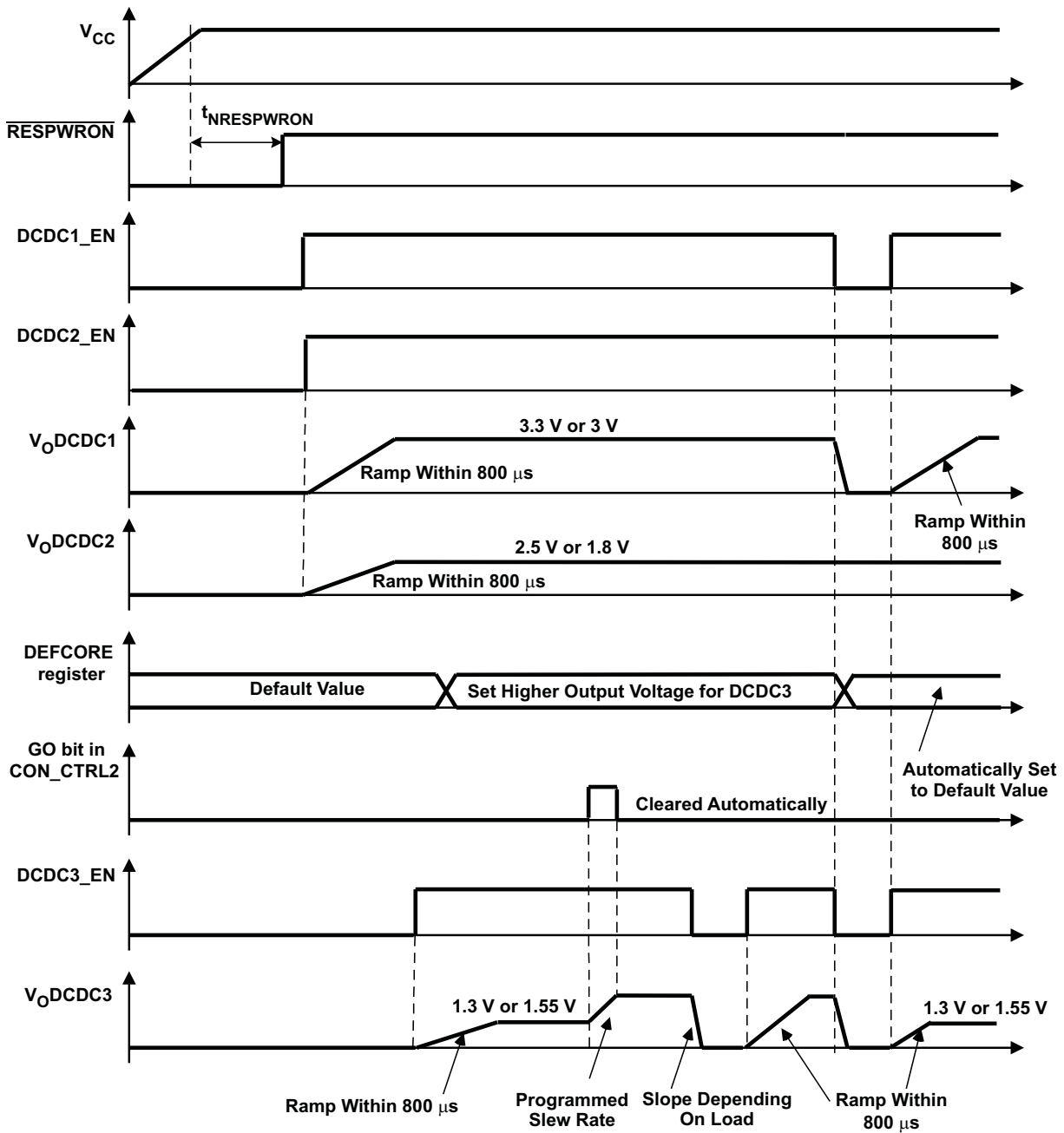

Figure 28. DVS Timing

SERIAL INTERFACE

The serial interface is compatible with the standard and fast mode I²C specifications, allowing transfers at up to 400 kHz. The interface adds flexibility to the power supply solution, enabling most functions to be programmed to new values depending on the instantaneous application requirements and charger status to be monitored. Register contents remain intact as long as V_{CC} remains above 2 V. The TPS65022 has a 7-bit address: 1001000, other addresses are available upon contact with the factory. Attempting to read data from the register addresses not listed in this section results in FFh being read out.

For normal data transfer, DATA is allowed to change only when CLK is low. Changes when CLK is high are reserved for indicating the start and stop conditions. During data transfer, the data line must remain stable

whenever the clock line is high. There is one clock pulse per bit of data. Each data transfer is initiated with a start condition and terminated with a stop condition. When addressed, the TPS65022 device generates an acknowledge bit after the reception of each byte. The master device (microprocessor) must generate an extra clock pulse that is associated with the acknowledge bit. The TPS65022 device must pull down the DATA line during the acknowledge clock pulse so that the DATA line is a stable low during the high period of the acknowledge clock pulse. The DATA line is a stable low during the high period of the acknowledge-related clock pulse. Setup and hold times must be taken into account. During read operations, a master must signal the end of data to the slave by not generating an acknowledge bit on the last byte that was clocked out of the slave. In this case, the slave TPS65022 device must leave the data line high to enable the master to generate the stop condition

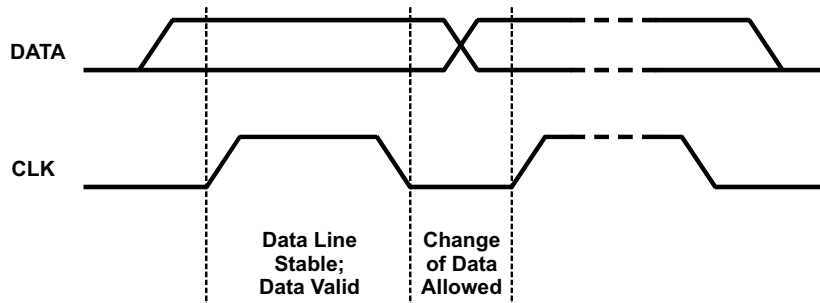

Figure 29. Bit Transfer on the Serial Interface

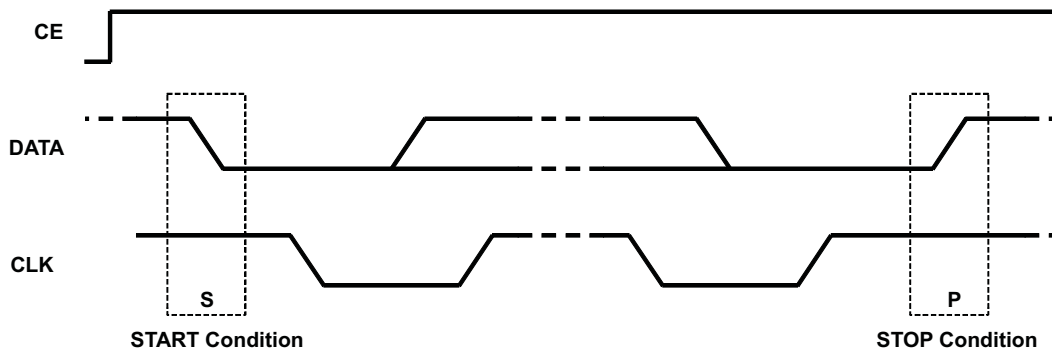
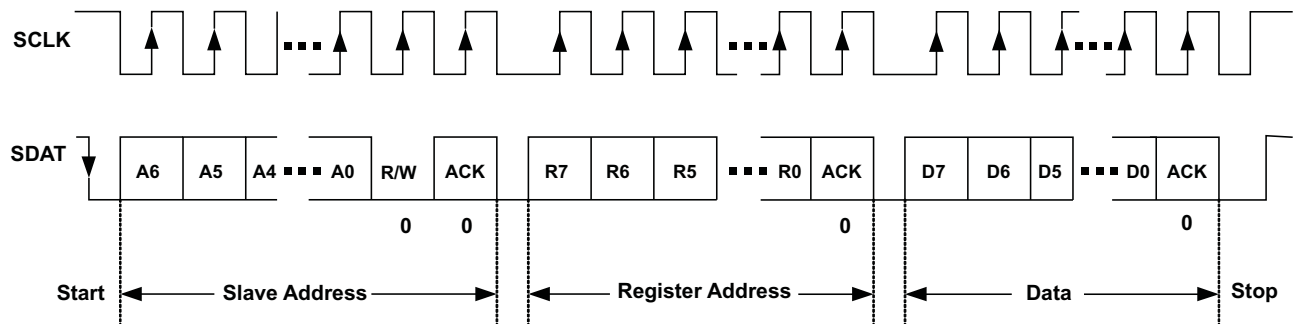

Figure 30. START and STOP Conditions



Note: SLAVE = TPS65020

Figure 31. Serial i/f WRITE to TPS65022 Device

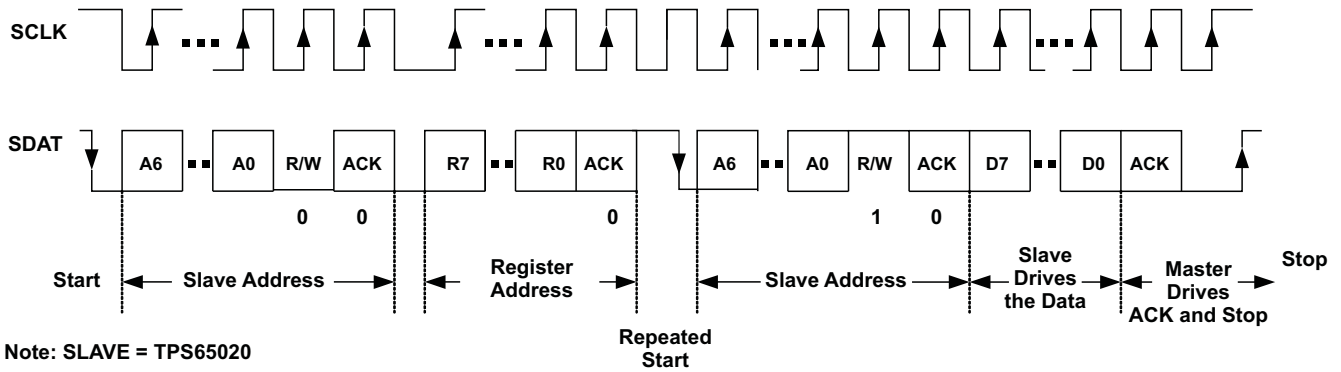

Figure 32. Serial i/f READ from TPS65022: Protocol A

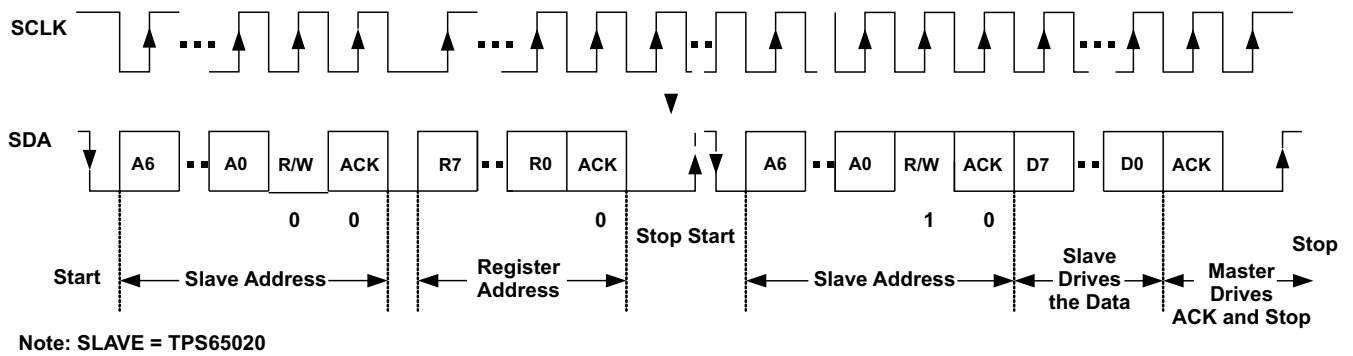

Figure 33. Serial i/f READ from TPS65022: Protocol B

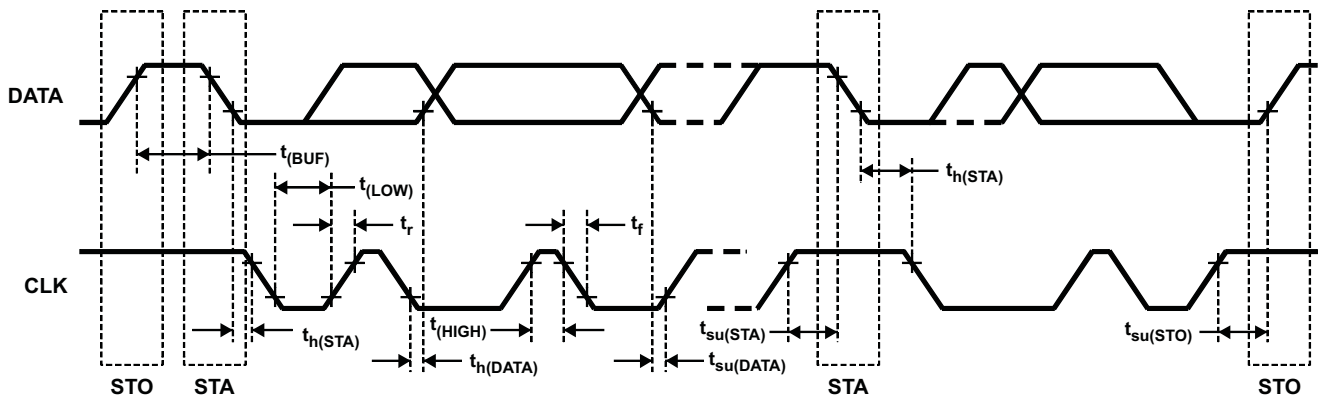

Figure 34. Serial i/f Timing Diagram

TPS65022

SLU5697 - JUNE 2006 [查询"TPS65022"供应商](#)

		MIN	MAX	UNIT
f_{MAX}	Clock frequency		400	kHz
$t_{WH(HIGH)}$	Clock high time	600		ns
$t_{WL(LOW)}$	Clock low time	1300		ns
t_R	DATA and CLK rise time		300	ns
t_F	DATA and CLK fall time		300	ns
$t_{h(STA)}$	Hold time (repeated) START condition (after this period the first clock pulse is generated)	600		ns
$t_{h(DATA)}$	Setup time for repeated START condition	600		ns
$t_{h(DATA)}$	Data input hold time	0		ns
$t_{su(DATA)}$	Data input setup time	100		ns
$t_{su(STO)}$	STOP condition setup time	600		ns
$t_{(BUF)}$	Bus free time	1300		ns

VERSION. Register Address: 00h (read only)

VERSION	B7	B6	B5	B4	B3	B2	B1	B0
Bit name and function	0	0	1	0	0	0	1	0
Read/Write	R	R	R	R	R	R	R	R

PGOODZ. Register Address: 01h (read only)

PGOODZ	B7	B6	B5	B4	B3	B2	B1	B0
Bit name and function	PWRFAILZ	LOWBATTZ	PGOODZ VDCDC1	PGOODZ VDCDC2	PGOODZ VDCDC3	PGOODZ LDO2	PGOODZ LDO1	
Set by signal	PWRFAIL	LOWBATT	PGOODZ VDCDC1	PGOODZ VDCDC2	PGOODZ VDCDC3	PGOODZ LDO2	PGOODZ LDO1	
Default value loaded by:	PWRFAILZ	LOWBATTZ	PGOOD VDCDC1	PGOOD VDCDC2	PGOOD VDCDC3	PGOOD LDO2	PGOOD LDO1	
Read/Write	R	R	R	R	R	R	R	R

Bit 7 PWRFAILZ:

- 0 = indicates that the PWRFAIL_SNS input voltage is above the 1-V threshold.
- 1 = indicates that the PWRFAIL_SNS input voltage is below the 1-V threshold.

Bit 6 LOWBATTZ:

- 0 = indicates that the LOWBATT_SNS input voltage is above the 1-V threshold.
- 1 = indicates that the LOWBATT_SNS input voltage is below the 1-V threshold.

Bit 5 PGOODZ VDCDC1:

- 0 = indicates that the VDCDC1 converter output voltage is within its nominal range. This bit is zero if the VDCDC1 converter is disabled.
- 1 = indicates that the VDCDC1 converter output voltage is below its target regulation voltage

Bit 4 PGOODZ VDCDC2:

- 0 = indicates that the VDCDC2 converter output voltage is within its nominal range. This bit is zero if the VDCDC2 converter is disabled.
- 1 = indicates that the VDCDC2 converter output voltage is below its target regulation voltage

Bit 3 PGOODZ VDCDC3: .

- 0 = indicates that the VDCDC3 converter output voltage is within its nominal range. This bit is zero if the VDCDC3 converter is disabled and during a DVM controlled output voltage transition
- 1 = indicates that the VDCDC3 converter output voltage is below its target regulation voltage

Bit 2 PGOODZ LDO2:

- 0 = indicates that the LDO2 output voltage is within its nominal range. This bit is zero if LDO2 is disabled.
- 1 = indicates that LDO2 output voltage is below its target regulation voltage

Bit 1 PGOODZ LDO1

- 0 = indicates that the LDO1 output voltage is within its nominal range. This bit is zero if LDO1 is disabled.
- 1 = indicates that the LDO1 output voltage is below its target regulation voltage

MASK. Register Address: 02h (read/write) Default Value: C0h

MASK	B7	B6	B5	B4	B3	B2	B1	B0
Bit name and function	MASK PWRFAILZ	MASK LOWBATTZ	MASK VDCDC1	MASK VDCDC2	MASK VDCDC3	MASK LDO2	MASK LDO1	
Default	1	1	0	0	0	0	0	0
Default value loaded by:	UVLO	UVLO	UVLO	UVLO	UVLO	UVLO	UVLO	
Read/Write	R/W	R/W	R/W	R/W	R/W	R/W	R/W	

The MASK register can be used to mask particular fault conditions from appearing at the \overline{INT} pin. MASK<n> = 1 masks PGOODZ<n>.

REG_CTRL. Register Address: 03h (read/write) Default Value: FFh

The REG_CTRL register is used to disable or enable the power supplies via the serial interface. The contents of the register are logically AND'ed with the enable pins to determine the state of the supplies. A UVLO condition resets the REG_CTRL to 0xFF, so the state of the supplies defaults to the state of the enable pin. The REG_CTRL bits are automatically reset to default when the corresponding enable pin is low.

REG_CTRL	B7	B6	B5	B4	B3	B2	B1	B0
Bit name and function			VDCDC1 ENABLE	VDCDC2 ENABLE	VDCDC3 ENABLE	LDO2 ENABLE	LDO1 ENABLE	
Default	1	1	1	1	1	1	1	1
Set by signal			DCDC1_ENZ	DCDC2_ENZ	DCDC3_ENZ	LDO_ENZ	LDO_ENZ	
Default value loaded by:			UVLO	UVLO	UVLO	UVLO	UVLO	
Read/Write			R/W	R/W	R/W	R/W	R/W	

Bit 5 VDCDC1 ENABLE

DCDC1 Enable. This bit is logically AND'ed with the state of the DCDC1_EN pin to turn on the DCDC1 converter. Reset to 1 by a UVLO condition, the bit can be written to 0 or 1 via the serial interface. The bit is reset to 1 when the pin DCDC1_EN is pulled to GND, allowing DCDC1 to turn on when DCDC1_EN returns high.

Bit 4 VDCDC2 ENABLE

DCDC2 Enable. This bit is logically AND'ed with the state of the DCDC2_EN pin to turn on the DCDC2 converter. Reset to 1 by a UVLO condition, the bit can be written to 0 or 1 via the serial interface. The bit is reset to 1 when the pin DCDC2_EN is pulled to GND, allowing DCDC2 to turn on when DCDC2_EN returns high.

Bit 3 VDCDC3 ENABLE

DCDC3 Enable. This bit is logically AND'ed with the state of the DCDC3_EN pin to turn on the DCDC3 converter. Reset to 1 by a UVLO condition, the bit can be written to 0 or 1 via the serial interface. The bit is reset to 1 when the pin DCDC3_EN is pulled to GND, allowing DCDC3 to turn on when DCDC3_EN returns high.

Bit 2 LDO2 ENABLE

LDO2 Enable. This bit is logically AND'ed with the state of the LDO2_EN pin to turn on LDO2. Reset to 1 by a UVLO condition, the bit can be written to 0 or 1 via the serial interface. The bit is reset to 1 when the pin LDO_EN is pulled to GND, allowing LDO2 to turn on when LDO_EN returns high.

Bit 1 LDO1 ENABLE

LDO1 Enable. This bit is logically AND'ed with the state of the LDO1_EN pin to turn on LDO1. Reset to 1 by a UVLO condition, the bit can be written to 0 or 1 via the serial interface. The bit is reset to 1 when the pin LDO_EN is pulled to GND, allowing LDO1 to turn on when LDO_EN returns high.

CON_CTRL. Register Address: 04h (read/write) Default Value: B1h

CON_CTRL	B7	B6	B5	B4	B3	B2	B1	B0
Bit name and function	DCDC2 PHASE1	DCDC2 PHASE0	DCDC3 PHASE1	DCDC3 PHASE0	LOW RIPPLE	FPWM DCDC2	FPWM DCDC1	FPWM DCDC3
Default	1	0	1	1	0	0	0	1
Default value loaded by:	UVLO	UVLO	UVLO	UVLO	UVLO	UVLO	UVLO	UVLO
Read/Write	R/W	R/W	R/W	R/W	R/W	R/W	R/W	R/W

The CON_CTRL register is used to force any or all of the converters into forced PWM operation, when low output voltage ripple is vital. It is also used to control the phase shift between the three converters in order to minimize the input rms current, hence reduce the required input blocking capacitance. The DCDC1 converter is taken as the reference and consequently has a fixed zero phase shift.

CON_CTRL<7:6>	DCDC2 CONVERTER DELAYED BY	CON_CTRL<5:4>	DCDC3 CONVERTER DELAYED BY
00	zero	00	zero
01	1/4 cycle	01	1/4 cycle
10	1/2 cycle	10	1/2 cycle
11	3/4 cycle	11	3/4 cycle

Bit 3 LOW RIPPLE:

- 0 = PFM mode operation optimized for high efficiency for all converters
- 1 = PFM mode operation optimized for low output voltage ripple for all converters

Bit 2 FPWM DCDC2:

- 0 = DCDC2 converter operates in PWM / PFM mode
- 1 = DCDC2 converter is forced into fixed frequency PWM mode

Bit 1 FPWM DCDC1:

- 0 = DCDC1 converter operates in PWM / PFM mode
- 1 = DCDC1 converter is forced into fixed frequency PWM mode

Bit 0 FPWM DCDC3:

- 0 = DCDC3 converter operates in PWM / PFM mode
- 1 = DCDC3 converter is forced into fixed frequency PWM mode

CON_CTRL2. Register Address: 05h (read/write) Default Value: 40h

CON_CTRL2	B7	B6	B5	B4	B3	B2	B1	B0
Bit name and function	GO	Core adj allowed				DCDC2 discharge	DCDC1 discharge	DCDC3 discharge
Default	0	1	0	0	0	0	0	0
Default value loaded by:	UVLO + DONE	RESET(1)				UVLO	UVLO	UVLO
Read/Write	R/W	R/W				R/W	R/W	R/W

The CON_CTRL2 register can be used to take control the inductive converters.

RESET(1): CON_CTRL2[6] is reset to its default value by one of these events:

- undervoltage lockout (UVLO)
- DCDC1_EN and DCDC3_EN pulled low
- $\overline{\text{HOT_RESET}}$ pulled low
- $\overline{\text{RESPWRON}}$ active
- VRTC below threshold

Bit 7 GO:

0 = no change in the output voltage for the DCDC3 converter

1 = the output voltage of the DCDC3 converter is changed to the value defined in DEFCORE with the slew rate defined in DEFSLEW. This bit is automatically cleared when the DVM transition is complete. The transition is considered complete in this case when the desired output voltage code has been reached, not when the VDCDC3 output voltage is actually in regulation at the desired voltage.

Bit 6 CORE ADJ Allowed:

0 = the output voltage is set with the I²C register

1 = DEFDCDC3 is either connected to GND or VCC or an external voltage divider. When connected to GND or VCC, VDCDC3 defaults to 1.3 V or 1.55 V respectively at start-up

Bit 2–0 0 = the output capacitor of the associated converter is not actively discharged when the converter is disabled

1 = the output capacitor of the associated converter is actively discharged when the converter is disabled. This decreases the fall time of the output voltage at light load

DEFCORE. Register Address: 06h (read/write) Default Value: 14h/1Eh

DEFCORE	B7	B6	B5	B4	B3	B2	B1	B0
Bit name and function				CORE4	CORE3	CORE2	CORE1	CORE0
Default	0	0	0	1	DEFDCDC3	1	DEFDCDC3	0
Default value loaded by:				RESET(2)	RESET(1)	RESET(1)	RESET(1)	RESET(2)
Read/Write				R/W	R/W	R/W	R/W	R/W

RESET(1): DEFCORE[3:1] are reset to the default value by one of these events:

- undervoltage lockout (UVLO)
- DCDC1_EN and DCDC3_EN pulled low
- $\overline{\text{HOT_RESET}}$ pulled low
- $\overline{\text{RESPWRON}}$ active
- VRTC below threshold

RESET(2): DEFCORE[4] and DEFCORE[0] are reset to the default value by one of these events:

- undervoltage lockout (UVLO)
- DCDC1_EN pulled low
- $\overline{\text{HOT_RESET}}$ pulled low
- $\overline{\text{RESPWRON}}$ active
- VRTC below threshold

CORE4	CORE3	CORE2	CORE1	CORE0	VDCDC3		CORE4	CORE3	CORE2	CORE1	CORE0	VDCDC3
0	0	0	0	0	0.8 V		1	0	0	0	0	1.2 V
0	0	0	0	1	0.825 V		1	0	0	0	1	1.225 V
0	0	0	1	0	0.85 V		1	0	0	1	0	1.25 V
0	0	0	1	1	0.875 V		1	0	0	1	1	1.275 V
0	0	1	0	0	0.9 V		1	0	1	0	0	1.3 V
0	0	1	0	1	0.925 V		1	0	1	0	1	1.325 V
0	0	1	1	0	0.95 V		1	0	1	1	0	1.35 V
0	0	1	1	1	0.975 V		1	0	1	1	1	1.375 V
0	1	0	0	0	1 V		1	1	0	0	0	1.4 V
0	1	0	0	1	1.025 V		1	1	0	0	1	1.425 V
0	1	0	1	0	1.05 V		1	1	0	1	0	1.45 V
0	1	0	1	1	1.075 V		1	1	0	1	1	1.475 V
0	1	1	0	0	1.1 V		1	1	1	0	0	1.5 V
0	1	1	0	1	1.125 V		1	1	1	0	1	1.525 V
0	1	1	1	0	1.15 V		1	1	1	1	0	1.55 V
0	1	1	1	1	1.175 V		1	1	1	1	1	1.6 V

DEFSLEW. Register Address: 07h (read/write) Default Value: 06h

DEFSLEW	B7	B6	B5	B4	B3	B2	B1	B0
Bit name and function						SLEW2	SLEW1	SLEW0
Default						1	1	0
Default value loaded by:						UVLO	UVLO	UVLO
Read/Write						R/W	R/W	R/W

SLEW2	SLEW1	SLEW0	VDCDC3 SLEW RATE
0	0	0	0.15 mV/μs
0	0	1	0.3 mV/μs
0	1	0	0.6 mV/μs
0	1	1	1.2 mV/μs
1	0	0	2.4 mV/μs
1	0	1	4.8 mV/μs
1	1	0	9.6 mV/μs
1	1	1	Immediate

LDO_CTRL. Register Address: 08h (read/write) Default Value: set with DEFLDO1 and DEFLDO2

LDO_CTRL	B7	B6	B5	B4	B3	B2	B1	B0
Bit name and function		LDO2_2	LDO2_1	LDO2_0		LDO1_2	LDO1_1	LDO1_0
Default		DEFLDOx	DEFLDOx	DEFLDOx		DEFLDOx	DEFLDOx	DEFLDOx
Default value loaded by:		UVLO	UVLO	UVLO		UVLO	UVLO	UVLO
Read/Write		R/W	R/W	R/W		R/W	R/W	R/W

The LDO_CTRL registers can be used to set the output voltage of LDO1 and LDO2.

The default voltage is set with DEFLDO1 and DEFLDO2 pins as described in [Table 3](#).

LDO1_2	LDO1_1	LDO1_0	LDO1 OUTPUT VOLTAGE	LDO2_2	LDO2_1	LDO2_0	LDO2 OUTPUT VOLTAGE
0	0	0	1 V	0	0	0	1.05 V
0	0	1	1.1 V	0	0	1	1.2 V
0	1	0	1.35 V	0	1	0	1.3 V
0	1	1	1.5 V	0	1	1	1.8 V
1	0	0	2.2 V	1	0	0	2.5 V
1	0	1	2.6 V	1	0	1	2.8 V
1	1	0	2.85 V	1	1	0	3 V
1	1	1	3.15 V	1	1	1	3.3 V

DESIGN PROCEDURE

Inductor Selection for the DC-DC Converters

Each of the converters in the TPS65022 typically use a 3.3 μ H output inductor. Larger or smaller inductor values are used to optimize the performance of the device for specific operation conditions. The selected inductor has to be rated for its dc resistance and saturation current. The dc resistance of the inductance influences directly the efficiency of the converter. Therefore, an inductor with lowest dc resistance should be selected for highest efficiency.

For a fast transient response, a 2.2- μ H inductor in combination with a 22- μ F output capacitor is recommended.

[Equation 4](#) calculates the maximum inductor current under static load conditions. The saturation current of the inductor should be rated higher than the maximum inductor current as calculated with [Equation 4](#). This is needed because during heavy load transient the inductor current rises above the value calculated under [Equation 4](#).

$$\Delta I_L = V_{out} \times \frac{1 - \frac{V_{out}}{V_{in}}}{L \times f} \quad (4)$$

$$I_{Lmax} = I_{outmax} + \frac{\Delta I_L}{2} \quad (5)$$

with:

f = Switching Frequency (1.5 MHz typical)

L = Inductor Value

ΔI_L = Peak-to-Peak inductor ripple current

I_{LMAX} = Maximum Inductor current

The highest inductor current occurs at maximum V_{in} .

Open core inductors have a soft saturation characteristic, and they can usually handle higher inductor currents versus a comparable shielded inductor.

A more conservative approach is to select the inductor current rating just for the maximum switch current of the TPS65022 (2 A for the VDCDC1 and VDCDC2 converters, and 1.5 A for the VDCDC3 converter). The core material from inductor to inductor differs and has an impact on the efficiency especially at high switching frequencies.

See [Table 4](#) and the typical applications for possible inductors.

Table 4. Tested Inductors

DEVICE	INDUCTOR VALUE	TYPE	COMPONENT SUPPLIER
DCDC3 converter	3.3 μH	CDRH2D14NP-3R3	Sumida
	3.3 μH	LPS3010-332	Coilcraft
	3.3 μH	VLF4012AT-3R3M1R3	TDK
	2.2 μH	VLF4012AT-2R2M1R5	TDK
DCDC2 converter	3.3 μH	CDRH2D18/HPNP-3R3	Sumida
	3.3 μH	VLF4012AT-3R3M1R3	TDK
	2.2 μH	VLCF4020-2R2	TDK
DCDC1 converter	3.3 μH	CDRH3D14/HPNP-3R2	Sumida
	3.3 μH	CDRH4D28C-3R2	Sumida
	3.3 μH	MSS5131-332	Coilcraft
	2.2 μH	VLCF4020-2R2	TDK

Output Capacitor Selection

The advanced Fast Response voltage mode control scheme of the inductive converters implemented in the TPS65022 allow the use of small ceramic capacitors with a typical value of 10 μF for each converter without having large output voltage under and overshoots during heavy load transients. Ceramic capacitors having low ESR values have the lowest output voltage ripple and are recommended. See [Table 5](#) for recommended components.

If ceramic output capacitors are used, the capacitor RMS ripple current rating always meets the application requirements. Just for completeness, the RMS ripple current is calculated as:

$$I_{\text{RMS}C_{\text{out}}} = V_{\text{out}} \times \frac{1 - \frac{V_{\text{out}}}{V_{\text{in}}}}{L \times f} \times \frac{1}{2 \times \sqrt{3}} \quad (6)$$

At nominal load current, the inductive converters operate in PWM mode. The overall output voltage ripple is the sum of the voltage spike caused by the output capacitor ESR plus the voltage ripple caused by charging and discharging the output capacitor:

$$\Delta V_{\text{out}} = V_{\text{out}} \times \frac{1 - \frac{V_{\text{out}}}{V_{\text{in}}}}{L \times f} \times \left(\frac{1}{8 \times C_{\text{out}} \times f} + \text{ESR} \right) \quad (7)$$

Where the highest output voltage ripple occurs at the highest input voltage V_{in} .

At light load currents, the converters operate in PSM and the output voltage ripple is dependent on the output capacitor value. The output voltage ripple is set by the internal comparator delay and the external capacitor. The typical output voltage ripple is less than 1% of the nominal output voltage.

Input Capacitor Selection

Because of the nature of the buck converter having a pulsating input current, a low ESR input capacitor is required for best input voltage filtering and minimizing the interference with other circuits caused by high input voltage spikes. Each dc-dc converter requires a 10- μ F ceramic input capacitor on its input pin VINDCDCx. The input capacitor is increased without any limit for better input voltage filtering. The VCC pin is separated from the input for the dc-dc converters. A filter resistor of up to 10R and a 1- μ F capacitor is used for decoupling the VCC pin from switching noise. Note that the filter resistor may affect the UVLO threshold since up to 3 mA can flow via this resistor into the VCC pin when all converters are running in PWM mode.

Table 5. Possible Capacitors

CAPACITOR VALUE	CASE SIZE	COMPONENT SUPPLIER	COMMENTS
22 μ F	1206	TDK C3216X5R0J226M	Ceramic
22 μ F	1206	Taiyo Yuden JMK316BJ226ML	Ceramic
22 μ F	0805	TDK C2012X5R0J226MT	Ceramic
22 μ F	0805	Taiyo Yuden JMK212BJ226MG	Ceramic
10 μ F	0805	Taiyo Yuden JMK212BJ106M	Ceramic
10 μ F	0805	TDK C2012X5R0J106M	Ceramic

Output Voltage Selection

The DEFDCDC1, DEFDCDC2, and DEFDCDC3 pins are used to set the output voltage for each step-down converter. See Table 6 for the default voltages if the pins are pulled to GND or to VCC. If a different voltage is needed, an external resistor divider can be added to the DEFDCDCx pin as shown in Figure 35.

The output voltage of VDCDC3 is set with the I²C interface. If the voltage is changed from the default, using the DEFDCDC3 pin, the output voltage only depends on the register value. Any resistor divider at DEFDCDC3 does not change the voltage set with the register.

Table 6.

PIN	LEVEL	DEFAULT OUTPUT VOLTAGE
DEFDCDC1	VCC	3.3 V
	GND	3 V
DEFDCDC2	VCC	2.5 V
	GND	1.8 V
DEFDCDC3	VCC	1.55 V
	GND	1.3 V

Using an external resistor divider at DEFDCDCx:

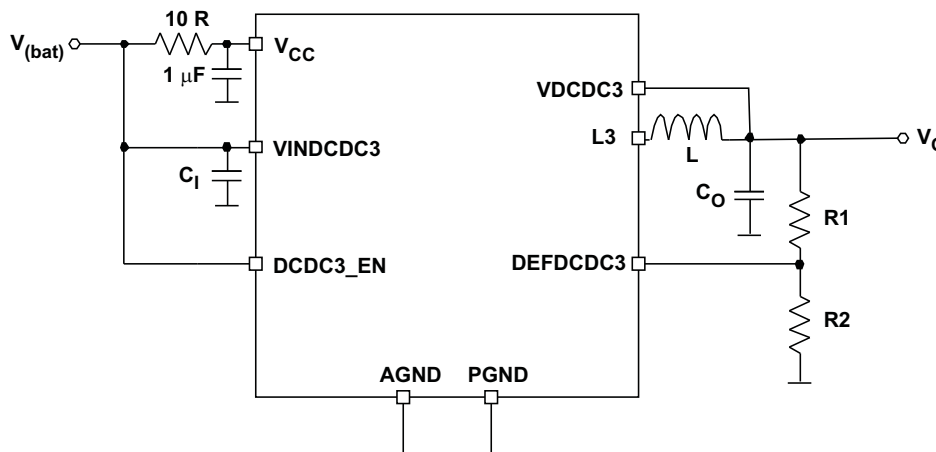

Figure 35. External Resistor Divider

When a resistor divider is connected to DEFDCDCx, the output voltage can be set from 0.6 V up to the input voltage $V_{(bat)}$. The total resistance ($R1+R2$) of the voltage divider should be kept in the 1-MR range in order to maintain a high efficiency at light load.

$$V_{(DEFDCDCx)} = 0.6 \text{ V}$$

$$V_{OUT} = V_{DEFDCDCx} \times \frac{R1 + R2}{R2} \quad R1 = R2 \times \left(\frac{V_{OUT}}{V_{DEFDCDCx}} \right) - R2 \quad (8)$$

VRTC Output

The VRTC output is typically connected to the Vcc_Batt pin of a Intel® PXA270 processor. During power-up of the processor, the TPS65022 internally switches from the LDO or the backup battery to the system voltage connected at the VSYSIN pin (see [Figure 25](#)). It is recommended that a 4.7-μF (minimum) capacitor be added to the VRTC pin.

LDO1 and LDO2

The LDOs in the TPS65022 are general-purpose LDOs which are stable using ceramics capacitors. The minimum output capacitor required is 2.2 μF. The LDOs output voltage can be changed to different voltages between 1 V and 3.3 V using the I²C interface. Therefore, they can also be used as general-purpose LDOs in applications powering processors different from PXA270. The supply voltage for the LDOs needs to be connected to the VINLDO pin, giving the flexibility to connect the lowest voltage available in the system and provides the highest efficiency.

TRESPWRON

This is the input to a capacitor that defines the reset delay time after the voltage at VRTC rises above 2.52 V. The timing is generated by charging and discharging the capacitor with a current of 2 μA between a threshold of 0.25 V and 1 V for 128 cycles. A 1-nF capacitor gives a delay time of 100 ms.

$$t_{(reset)} = 2 \times 128 \times \left(\frac{(1 \text{ V} - 0.25 \text{ V}) \times C_{(reset)}}{2 \mu\text{A}} \right) \quad (9)$$

Where:

$t_{(reset)}$ is the reset delay time

$C_{(reset)}$ is the capacitor connected to the TRESPWRON pin

V_{CC}-Filter

An RC filter connected at the VCC input is used to keep noise from the internal supply for the bandgap and other analog circuitry. A typical value of 10 R and 1 μF is used to filter the switching spikes, generated by the dc-dc converters. A larger resistor than 10 R should not be used because the current into VCC of up to 3 mA causes a voltage drop at the resistor causing the undervoltage lockout circuitry connected at VCC internally to switch off too early.

APPLICATION INFORMATION

TYPICAL CONFIGURATION FOR THE Intel® PXA270 BULVERDE PROCESSOR

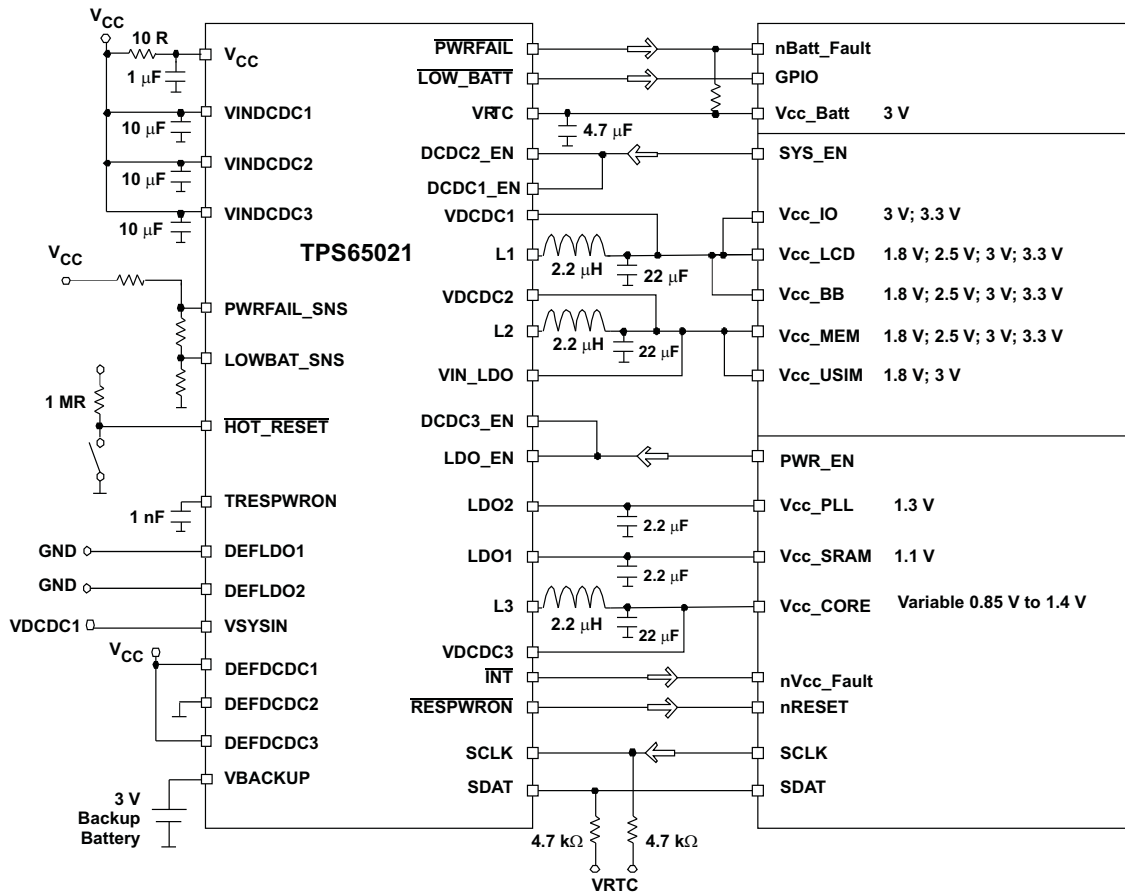

PACKAGING INFORMATION

Orderable Device	Status ⁽¹⁾	Package Type	Package Drawing	Pins	Package Qty	Eco Plan ⁽²⁾	Lead/Ball Finish	MSL Peak Temp ⁽³⁾
TPS65022RHAR	ACTIVE	VQFN	RHA	40	2500	Green (RoHS & no Sb/Br)	CU NIPDAU	Level-3-260C-168 HR
TPS65022RHARG4	ACTIVE	VQFN	RHA	40	2500	Green (RoHS & no Sb/Br)	CU NIPDAU	Level-3-260C-168 HR
TPS65022RHAT	ACTIVE	VQFN	RHA	40	250	Green (RoHS & no Sb/Br)	CU NIPDAU	Level-3-260C-168 HR
TPS65022RHATG4	ACTIVE	VQFN	RHA	40	250	Green (RoHS & no Sb/Br)	CU NIPDAU	Level-3-260C-168 HR

⁽¹⁾ The marketing status values are defined as follows:

ACTIVE: Product device recommended for new designs.

LIFEBUY: TI has announced that the device will be discontinued, and a lifetime-buy period is in effect.

NRND: Not recommended for new designs. Device is in production to support existing customers, but TI does not recommend using this part in a new design.

PREVIEW: Device has been announced but is not in production. Samples may or may not be available.

OBSOLETE: TI has discontinued the production of the device.

⁽²⁾ Eco Plan - The planned eco-friendly classification: Pb-Free (RoHS), Pb-Free (RoHS Exempt), or Green (RoHS & no Sb/Br) - please check <http://www.ti.com/productcontent> for the latest availability information and additional product content details.

TBD: The Pb-Free/Green conversion plan has not been defined.

Pb-Free (RoHS): TI's terms "Lead-Free" or "Pb-Free" mean semiconductor products that are compatible with the current RoHS requirements for all 6 substances, including the requirement that lead not exceed 0.1% by weight in homogeneous materials. Where designed to be soldered at high temperatures, TI Pb-Free products are suitable for use in specified lead-free processes.

Pb-Free (RoHS Exempt): This component has a RoHS exemption for either 1) lead-based flip-chip solder bumps used between the die and package, or 2) lead-based die adhesive used between the die and leadframe. The component is otherwise considered Pb-Free (RoHS compatible) as defined above.

Green (RoHS & no Sb/Br): TI defines "Green" to mean Pb-Free (RoHS compatible), and free of Bromine (Br) and Antimony (Sb) based flame retardants (Br or Sb do not exceed 0.1% by weight in homogeneous material)

⁽³⁾ MSL, Peak Temp. -- The Moisture Sensitivity Level rating according to the JEDEC industry standard classifications, and peak solder temperature.

Important Information and Disclaimer:The information provided on this page represents TI's knowledge and belief as of the date that it is provided. TI bases its knowledge and belief on information provided by third parties, and makes no representation or warranty as to the accuracy of such information. Efforts are underway to better integrate information from third parties. TI has taken and continues to take reasonable steps to provide representative and accurate information but may not have conducted destructive testing or chemical analysis on incoming materials and chemicals. TI and TI suppliers consider certain information to be proprietary, and thus CAS numbers and other limited information may not be available for release.

In no event shall TI's liability arising out of such information exceed the total purchase price of the TI part(s) at issue in this document sold by TI to Customer on an annual basis.

[查询"TPS65022"供应商](#)

RHA (S-PVQFN-N40)

PLASTIC QUAD FLATPACK NO-LEAD

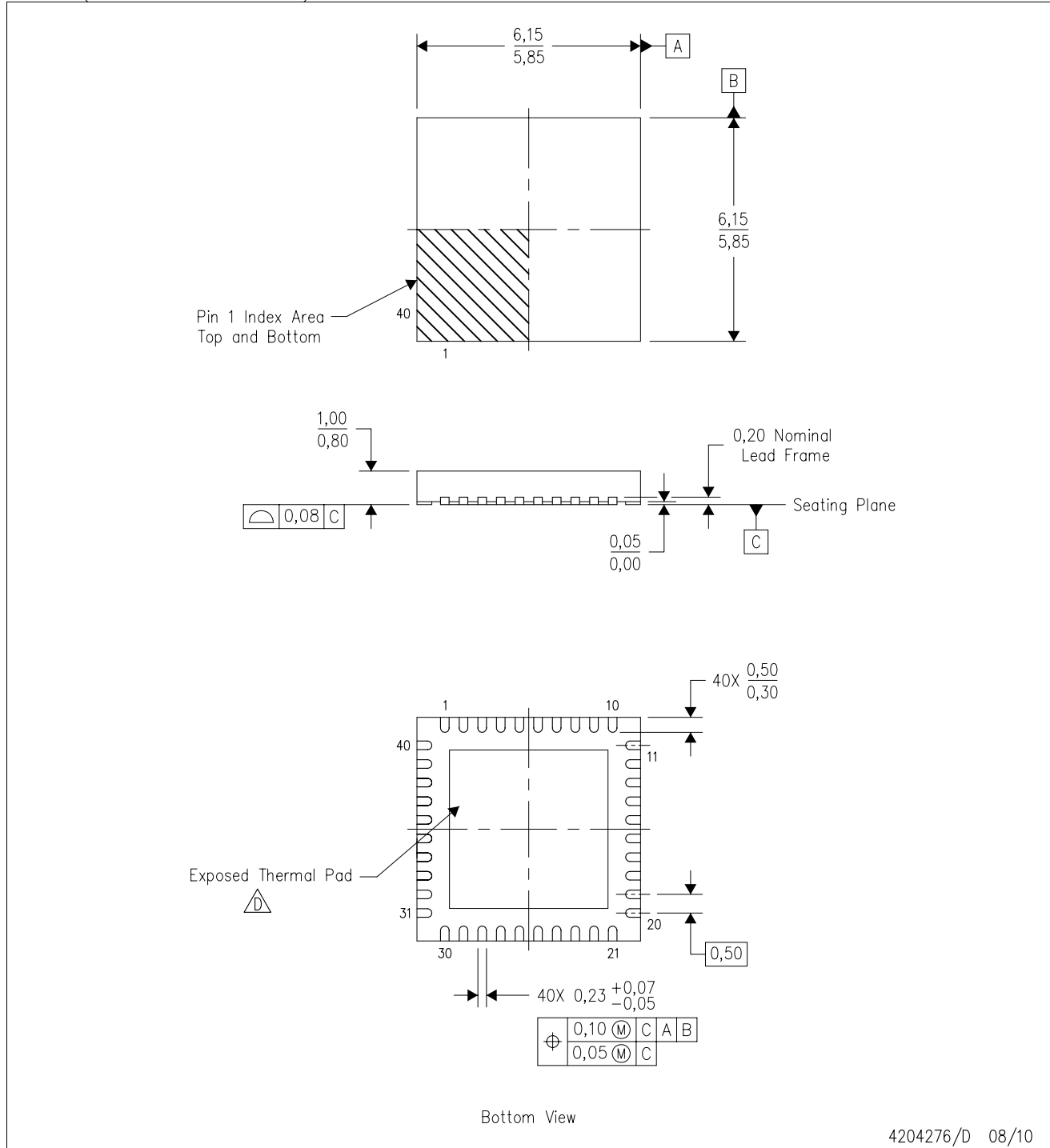

- NOTES:
- All linear dimensions are in millimeters. Dimensioning and tolerancing per ASME Y14.5M-1994.
 - This drawing is subject to change without notice.
 - QFN (Quad Flatpack No-Lead) Package configuration.
 - The package thermal pad must be soldered to the board for thermal and mechanical performance. See the Product Data Sheet for details regarding the exposed thermal pad dimensions.
 - Package complies to JEDEC MO-220 variation VJJD-2.

IMPORTANT NOTICE

Texas Instruments Incorporated and its subsidiaries (TI) reserve the right to make corrections, modifications, enhancements, improvements, and other changes to its products and services at any time and to discontinue any product or service without notice. Customers should obtain the latest relevant information before placing orders and should verify that such information is current and complete. All products are sold subject to TI's terms and conditions of sale supplied at the time of order acknowledgment.

TI warrants performance of its hardware products to the specifications applicable at the time of sale in accordance with TI's standard warranty. Testing and other quality control techniques are used to the extent TI deems necessary to support this warranty. Except where mandated by government requirements, testing of all parameters of each product is not necessarily performed.

TI assumes no liability for applications assistance or customer product design. Customers are responsible for their products and applications using TI components. To minimize the risks associated with customer products and applications, customers should provide adequate design and operating safeguards.

TI does not warrant or represent that any license, either express or implied, is granted under any TI patent right, copyright, mask work right, or other TI intellectual property right relating to any combination, machine, or process in which TI products or services are used. Information published by TI regarding third-party products or services does not constitute a license from TI to use such products or services or a warranty or endorsement thereof. Use of such information may require a license from a third party under the patents or other intellectual property of the third party, or a license from TI under the patents or other intellectual property of TI.

Reproduction of TI information in TI data books or data sheets is permissible only if reproduction is without alteration and is accompanied by all associated warranties, conditions, limitations, and notices. Reproduction of this information with alteration is an unfair and deceptive business practice. TI is not responsible or liable for such altered documentation. Information of third parties may be subject to additional restrictions.

Resale of TI products or services with statements different from or beyond the parameters stated by TI for that product or service voids all express and any implied warranties for the associated TI product or service and is an unfair and deceptive business practice. TI is not responsible or liable for any such statements.

TI products are not authorized for use in safety-critical applications (such as life support) where a failure of the TI product would reasonably be expected to cause severe personal injury or death, unless officers of the parties have executed an agreement specifically governing such use. Buyers represent that they have all necessary expertise in the safety and regulatory ramifications of their applications, and acknowledge and agree that they are solely responsible for all legal, regulatory and safety-related requirements concerning their products and any use of TI products in such safety-critical applications, notwithstanding any applications-related information or support that may be provided by TI. Further, Buyers must fully indemnify TI and its representatives against any damages arising out of the use of TI products in such safety-critical applications.

TI products are neither designed nor intended for use in military/aerospace applications or environments unless the TI products are specifically designated by TI as military-grade or "enhanced plastic." Only products designated by TI as military-grade meet military specifications. Buyers acknowledge and agree that any such use of TI products which TI has not designated as military-grade is solely at the Buyer's risk, and that they are solely responsible for compliance with all legal and regulatory requirements in connection with such use.

TI products are neither designed nor intended for use in automotive applications or environments unless the specific TI products are designated by TI as compliant with ISO/TS 16949 requirements. Buyers acknowledge and agree that, if they use any non-designated products in automotive applications, TI will not be responsible for any failure to meet such requirements.

Following are URLs where you can obtain information on other Texas Instruments products and application solutions:

Products		Applications	
Amplifiers	amplifier.ti.com	Audio	www.ti.com/audio
Data Converters	dataconverter.ti.com	Automotive	www.ti.com/automotive
DLP® Products	www.dlp.com	Communications and Telecom	www.ti.com/communications
DSP	dsp.ti.com	Computers and Peripherals	www.ti.com/computers
Clocks and Timers	www.ti.com/clocks	Consumer Electronics	www.ti.com/consumer-apps
Interface	interface.ti.com	Energy	www.ti.com/energy
Logic	logic.ti.com	Industrial	www.ti.com/industrial
Power Mgmt	power.ti.com	Medical	www.ti.com/medical
Microcontrollers	microcontroller.ti.com	Security	www.ti.com/security
RFID	www.ti-rfid.com	Space, Avionics & Defense	www.ti.com/space-avionics-defense
RF/IF and ZigBee® Solutions	www.ti.com/lprf	Video and Imaging	www.ti.com/video
		Wireless	www.ti.com/wireless-apps