

# ZERO RECOVERY™ RECTIFIER

## Features

- 600 Volt Schottky Rectifier
- Zero Reverse Recovery
- Zero Forward Recovery
- High Frequency Operation
- Temperature Independent Switching Behavior
- Extremely Fast Switching
- Positive Temperature Coefficient on  $V_f$

## Benefits

- Replace Bipolar with Unipolar Rectifiers
- Essentially No Switching Losses
- Higher Efficiency
- Reduction Of Rectifier Heat Sink
- Parallel Devices without Thermal Runaway

## Applications

- Switch Mode Power Supplies
- Power Factor Correction
- Motor Control

## Package

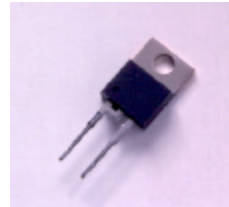

## Maximum Ratings

Parameter	Symbol	Value	Unit
Repetitive Peak Reverse Voltage	$V_{RRM}$	600	V
Surge Peak Reverse Voltage	$V_{RSM}$	600	V
DC Blocking Voltage	$V_{DC}$	600	V
Average Forward Current $T_C=150^\circ\text{C}$	$I_{F(AV)}$	1	A
Repetitive Peak Forward Surge Current $T_C=25^\circ\text{C}$ , $t_p=8.3\text{ms}$ , Half Sine Wave	$I_{FRM}$	5	A
Non-Repetitive Peak Forward Surge Current $T_C=25^\circ\text{C}$ , $t_p=10\mu\text{s}$ , Pulse	$I_{FSM}$	20	A
Power Dissipation $T_C = 25^\circ\text{C}$	$P_{tot}$	21.4	W
Operating Junction and Storage Temperature	$T_J, T_{stg}$	-55 to +175	$^\circ\text{C}$

**ELECTRICAL CHARACTERISTICS**

Parameter	Symbol	Min	Typ	Max	Units
Forward Voltage $I_F = 1A$ $T_J = 25^\circ C$ $I_F = 1A$ $T_J = 150^\circ C$	$V_F$		1.6 2.0	1.8 2.4	V
Reverse Current $V_R = 600V$ $T_J = 25^\circ C$ $V_R = 600V$ $T_J = 150^\circ C$	$I_R$		20 40	100 500	$\mu A$
Total Capacitive Charge $V_R = 600V, I_F = 1A, di/dt = 500 A/\mu s, T_J = 25^\circ C$	$Q_C$		3.3		nC
Total Capacitance $V_R = 0V, T_J = 25^\circ C, f = 1MHz$ $V_R = 200V, T_J = 25^\circ C, f = 1MHz$ $V_R = 400V, T_J = 25^\circ C, f = 1MHz$	C		80 11 8.5		pF

NOTE:

1. This is a majority carrier diode, so there is no reverse recovery charge.

**THERMAL CHARACTERISTICS**

Characteristic	Symbol	Min	Typ	Max	Units
Thermal Resistance from Junction to Case	$R_{\theta JC}$		7		$^\circ C/W$
Thermal Resistance from Junction to Ambient	$R_{\theta JA}$		60		$^\circ C/W$

**Typical Performance**

**Figure 1. Forward Characteristics**

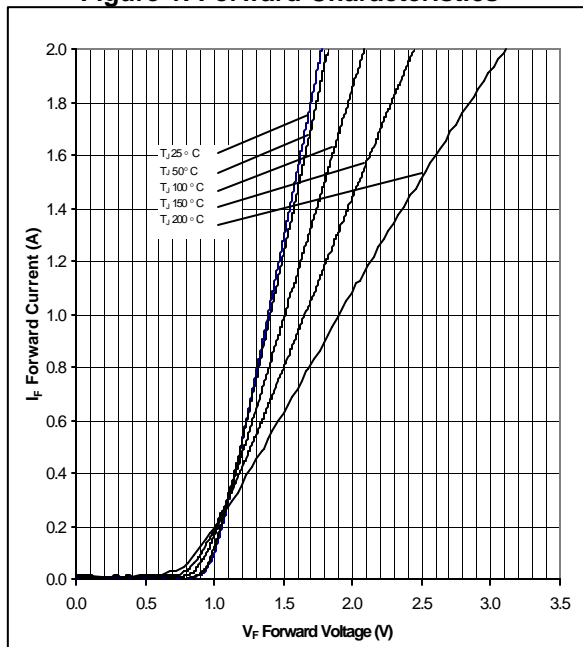

**Figure 2. Reverse Characteristics**

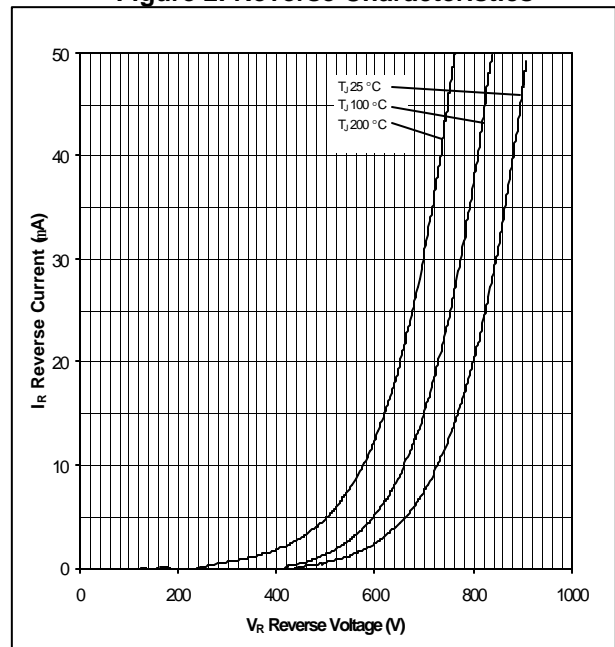

Figure 3. Current Derating

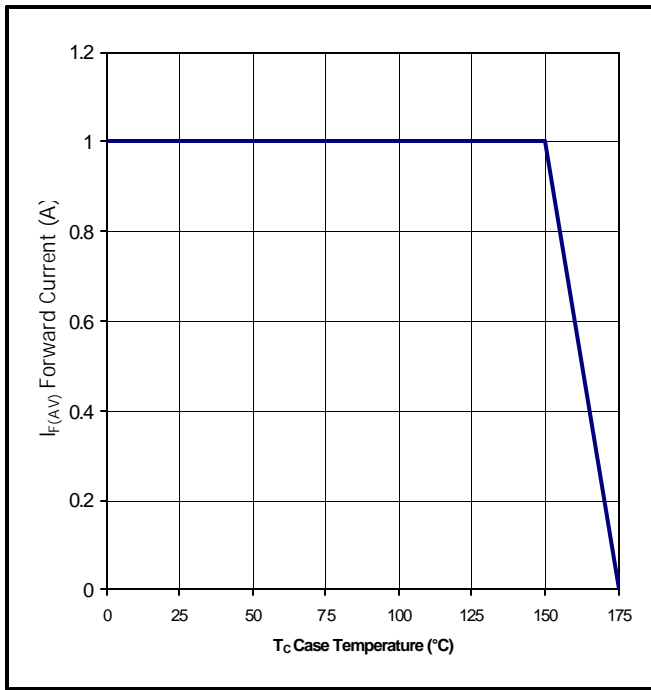
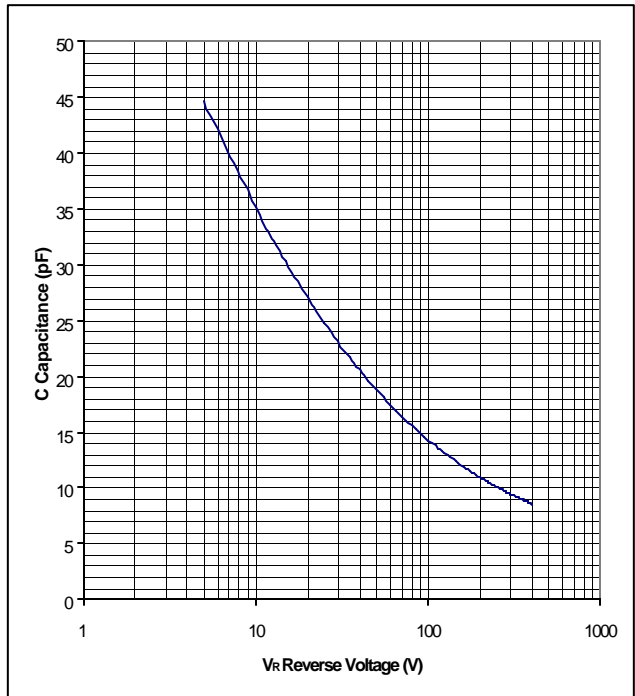
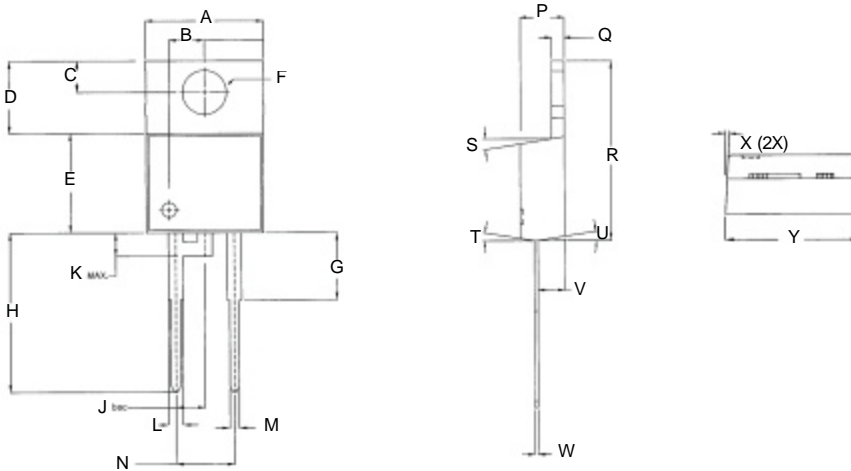

Figure 4. Capacitance vs. Reverse Voltage



**Package Dimensions**

**Package TO-220-2**



POS	Inches		Millimeters	
	Min	Max	Min	Max
A	.402	.408	10.211	10.364
B	.120	.124	3.048	3.150
C	.106	.110	2.692	2.794
D	.245	.251	6.223	6.375
E	.335	.345	8.509	8.763
F	.149	.153	3.784	3.886
G	.220	.240	5.588	6.096
H	.540	.550	13.716	13.970
J	.100 REF		2.540 REF	
K		.080		2.032
L	.050	.056	1.270	1.422
M	.032	.038	.813	.956
N	.197	.203	5.004	5.156
P	.170	.180	4.318	4.572
Q	.048	.052	1.219	1.321
R	.583	.593	14.808	15.062
S	6.5°	8.5°	6.5°	8.5°
T	6.5°	8.5°	6.5°	8.5°
U	6.5°	8.5°	6.5°	8.5°
V	.103	.107	2.616	2.718
W	.015	.021	.381	.533
X	2.0°	4.0°	2.0°	4.0°
Y	.396	.406	10.058	10.312

NOTE:

1. Dimension L, M, W apply for Solder Dip Finish.

**Package TO-252-2**

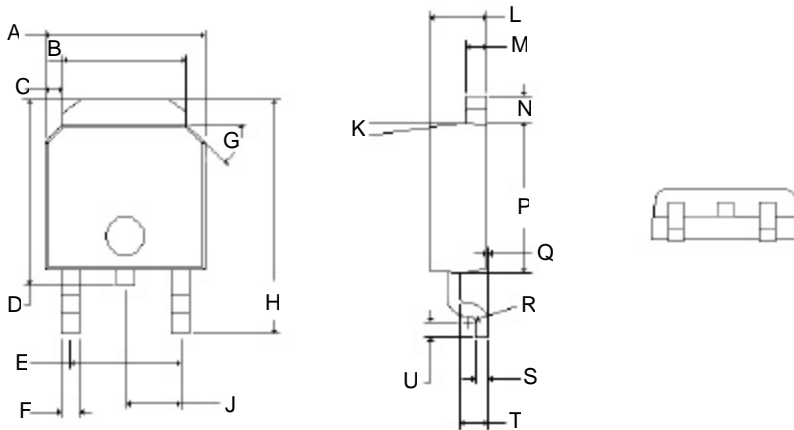

POS	Inches		Millimeters	
	Min	Max	Min	Max
A	.255	.265	6.477	6.731
B	.197	.205	5.004	5.207
C	.027	.033	.686	.838
D	.292	.322	7.417	8.179
E	.178	.182	4.521	4.623
F	.025	.035	.635	.889
G	44°	46°	44°	46°
H	.382	.397	9.703	10.084
J	.090TYP		2.286TYP	
K	6°	8°	6°	8°
L	.086	.094	2.184	2.388
M	.030	.034	.762	.864
N	.040	.044	1.016	1.118
P	.235	.245	5.969	6.223
Q	0.00	.004	0.00	.102
R	R0.01TYP		R0.31TYP	
S	.017	.023	.428	.588
T	.040	.044	1.016	1.118
U	.021	.027	.534	.686

Part Number	Package	Marking
CSD01060A	TO-220-2	SD01060
CSD01060E	TO-252-2	SD01060

Cree, Inc.  
Power Products  
4600 Silicon Drive  
Durham, NC 27703 • USA  
tel: 919-313-5300  
fax: 919-313-5451  
[www.cree.com](http://www.cree.com)

Copyright © 2001 Cree, Inc. All rights reserved.  
Permission is given to reproduce this document  
provided the entire document (including this  
copyright notice) is duplicated.

The information in this document is subject to  
change without notice.

Cree and the Cree logo are trademarks of Cree,  
Inc.