



查询"100114DC"供应商

F100114 Quint Differential Line Receiver

General Description

The F100114 is a monolithic quint differential line receiver with emitter-follower outputs. An internal reference supply (V_{BB}) is available for single-ended reception. When used in single-ended operation the apparent input threshold of the true inputs is 25 mV to 30 mV higher (positive) than the threshold of the complementary inputs. Unlike other F100K ECL devices, the inputs do not have input pull-down resistors.

Active current sources provide common-mode rejection of 1.0V in either the positive or negative direction. A defined output state exists if both inverting and non-inverting inputs are at the same potential between V_{EE} and V_{CC} . The defined state is logic HIGH on the $\bar{O}_a-\bar{O}_e$ outputs.

Refer to the F100314 datasheet for:

- PCC packaging
- Lower power
- Military versions
- Extended voltage specs (-4.2V to -5.7V)

Ordering Code: See Section 8

Logic Symbol

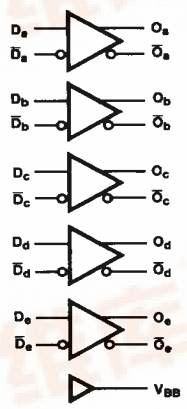

TL/F/9841-3

Pin Names	Description
D_a-D_e	Data Inputs
$\bar{D}_a-\bar{D}_e$	Inverting Data Inputs
O_a-O_e	Data Outputs
$\bar{O}_a-\bar{O}_e$	Complementary Data Outputs

Connection Diagrams

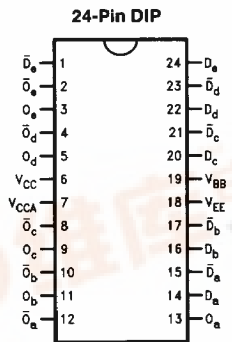

TL/F/9841-1

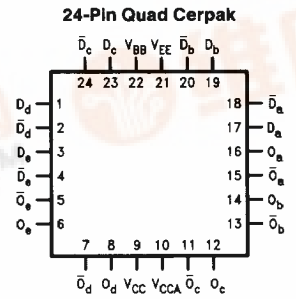

TL/F/9841-2

3



Absolute Maximum Ratings

Above which the useful life may be impaired (Note 1)

If Military/Aerospace specified devices are required, please contact the National Semiconductor Sales Office/Distributors for availability and specifications.

Storage Temperature -65°C to +150°C
Maximum Junction Temperature (T_J) +150°C

Case Temperature under Bias (T_C) 0°C to +85°C
V_{EE} Pin Potential to Ground Pin -7.0V to +0.5V
Input Voltage (DC) V_{EE} to +0.5V
Output Current (DC Output HIGH) -50 mA
Operating Range (Note 2) -5.7V to -4.2V

DC Electrical Characteristics

V_{EE} = -4.5V, V_{CC} = V_{CCA} = GND, T_C = 0°C to +85°C (Note 3)

Symbol	Parameter	Min	Typ	Max	Units	Conditions (Note 4)	
V _{OH}	Output HIGH Voltage	-1025	-955	-880	mV	V _{IN} = V _{IH} (Max) or V _{IL} (Min)	Loading with 50Ω to -2.0V
V _{OL}	Output LOW Voltage	-1810	-1705	-1620			
V _{OHC}	Output HIGH Voltage	-1035			mV	V _{IN} = V _{IH} (Min) or V _{IL} (Max)	Loading with 50Ω to -2.0V
V _{OLC}	Output LOW Voltage			-1610			
V _{BB}	Output Reference Voltage	-1380	-1320	-1260	mV	I _{VBB} = -250 μA	
V _{IH}	Single-Ended Input HIGH Voltage	-1165			mV	Guaranteed HIGH Signal for All Inputs (with one input tied to V _{BB})	
V _{IL}	Single-Ended Input LOW Voltage			-1475	mV	Guaranteed LOW Signal for All Inputs (with one input tied to V _{BB})	

DC Electrical Characteristics

V_{EE} = -4.2V, V_{CC} = V_{CCA} = GND, T_C = 0°C to +85°C (Note 3)

Symbol	Parameter	Min	Typ	Max	Units	Conditions (Note 4)	
V _{OH}	Output HIGH Voltage	-1020		-870	mV	V _{IN} = V _{IH} (Max) or V _{IL} (Min)	Loading with 50Ω to -2.0V
V _{OL}	Output LOW Voltage	-1810		-1605			
V _{OHC}	Output HIGH Voltage	-1030			mV	V _{IN} = V _{IH} (Min) or V _{IL} (Max)	Loading with 50Ω to -2.0V
V _{OLC}	Output LOW Voltage			-1595			
V _{BB}	Output Reference Voltage	-1396	-1320	-1244	mV	I _{VBB} = -250 μA	
V _{IH}	Single-Ended Input HIGH Voltage	-1150			mV	Guaranteed HIGH Signal for All Inputs (with one input tied to V _{BB})	
V _{IL}	Single-Ended Input LOW Voltage			-1475	mV	Guaranteed LOW Signal for All Inputs (with one input tied to V _{BB})	

DC Electrical Characteristics

V_{EE} = -4.8V, V_{CC} = V_{CCA} = GND, T_C = 0°C to +85°C (Note 3)

Symbol	Parameter	Min	Typ	Max	Units	Conditions (Note 4)	
V _{OH}	Output HIGH Voltage	-1035		-880	mV	V _{IN} = V _{IH} (Max) or V _{IL} (Min)	Loading with 50Ω to -2.0V
V _{OL}	Output LOW Voltage	-1830		-1620			
V _{OHC}	Output HIGH Voltage	-1045			mV	V _{IN} = V _{IH} (Min) or V _{IL} (Max)	Loading with 50Ω to -2.0V
V _{OLC}	Output LOW Voltage			-1610			
V _{BB}	Output Reference Voltage	-1396	-1320	-1244	mV	I _{VBB} = -250 μA	
V _{IH}	Single-Ended Input HIGH Voltage	-1165			mV	Guaranteed HIGH Signal for All Inputs (with one input tied to V _{BB})	
V _{IL}	Single-Ended Input LOW Voltage			-1490	mV	Guaranteed LOW Signal for All Inputs (with one input tied to V _{BB})	

Note 1: Absolute maximum ratings are those values beyond which the device may be damaged or have its useful life impaired. Functional operation under these conditions is not implied.

Note 2: Parametric values specified at -4.2V to -4.8V.

Note 3: The specified limits represent the "worst case" value for the parameter. Since these "worst case" values normally occur at the temperature extremes, additional noise immunity and guard banding can be achieved by decreasing the allowable system operating ranges.

Note 4: Conditions for testing shown in the tables are chosen to guarantee operation under "worst case" conditions.

DC Electrical Characteristics
 $V_{EE} = -4.2V$ to $-4.8V$ unless otherwise specified, $V_{CC} = V_{CCA} = GND$, $T_C = 0^\circ C$ to $+85^\circ C$

Symbol	Parameter	Min	Typ	Max	Units	Conditions
V_{DIFF}	Input Voltage Differential	150			mV	Required for Full Output Swing
V_{CM}	Common Mode Voltage			1.0	V	Permissible $\pm V_{CM}$ with Respect to V_{BB}
I_{IH}	Input HIGH Current			50	μA	$V_{IN} = V_{IH} (Max)$, $D_a - D_e = V_{BB}$, $\bar{D}_a - \bar{D}_e = V_{IL} (Min)$
I_{CBO}	Input Leakage Current	-10			μA	$V_{IN} = V_{EE}$, $D_a - D_e = V_{BB}$, $\bar{D}_a - \bar{D}_e = V_{IL} (Min)$
I_{EE}	Power Supply Current	-106	-73	-51	mA	$D_a - D_e = V_{BB}$, $\bar{D}_a - \bar{D}_e = V_{IL} (Min)$

Ceramic Dual-In-Line Package AC Electrical Characteristics
 $V_{EE} = -4.2V$ to $-4.8V$, $V_{CC} = V_{CCA} = GND$

Symbol	Parameter	$T_C = 0^\circ C$		$T_C = +25^\circ C$		$T_C = +85^\circ C$		Units	Conditions
		Min	Max	Min	Max	Min	Max		
t_{PLH} t_{PHL}	Propagation Delay Data to Output	0.55	1.90	0.60	2.00	0.70	2.40	ns	Figures 1 and 2
t_{TLH} t_{THL}	Transition Time 20% to 80%, 80% to 20%	0.55	1.30	0.45	1.20	0.45	1.40	ns	

Cerpak AC Electrical Characteristics
 $V_{EE} = -4.2V$ to $-4.8V$, $V_{CC} = V_{CCA} = GND$

Symbol	Parameter	$T_C = 0^\circ C$		$T_C = +25^\circ C$		$T_C = +85^\circ C$		Units	Conditions
		Min	Max	Min	Max	Min	Max		
t_{PLH} t_{PHL}	Propagation Delay Data to Output	0.55	1.70	0.60	1.80	0.70	2.20	ns	Figures 1 and 2
t_{TLH} t_{THL}	Transition Time 20% to 80%, 80% to 20%	0.55	1.20	0.45	1.10	0.45	1.30	ns	

[查询"100114DC"供应商](#)

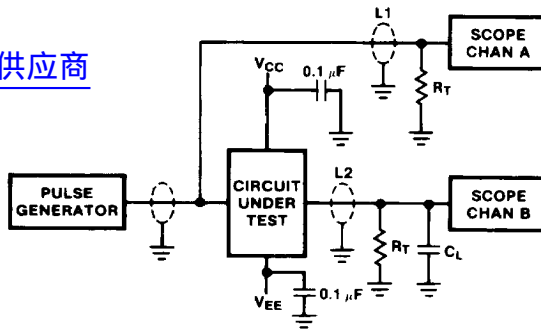

TL/F/9841-5

Notes:

- $V_{CC}, V_{CCA} = +2V, V_{EE} = -2.5V$
- $L1$ and $L2 =$ equal length 50Ω impedance lines
- $R_T = 50\Omega$ terminator internal to scope
- Decoupling $0.1 \mu F$ from GND to V_{CC} and V_{EE}
- All unused outputs are loaded with 50Ω to GND
- $C_L =$ Fixture and stray capacitance $\leq 3 pF$

FIGURE 1. AC Test Circuit

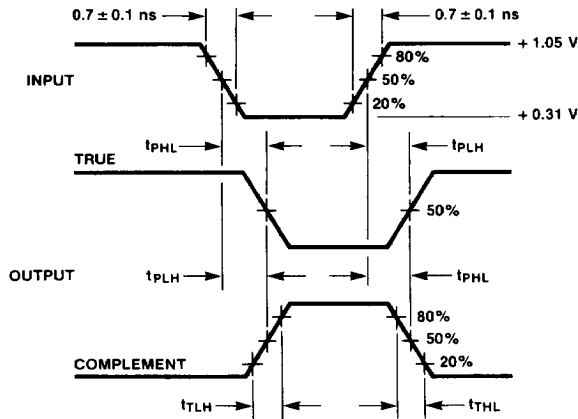

TL/F/9841-6

FIGURE 2. Propagation Delay and Transition Times