

Fixed Frequency, 99% Duty Cycle Peak Current Mode Notebook System Power Controller

Check for Samples: [TPS51220A](#)

FEATURES

- Input Voltage Range: 4.5 V to 32 V
- Output Voltage Range: 1 V to 12 V
- Selectable Light Load Operation (Continuous / Auto Skip / Out-Of-Audio™ Skip)
- Programmable Droop Compensation
- Voltage Servo Adjustable Soft Start
- 200-kHz to 1-MHz Fixed-Frequency PWM
- Selectable Current/ D-CAP™ Mode Architecture
- 180° Phase Shift Between Channels
- Resistor or Inductor DCR Current Sensing
- Adaptive Zero Crossing Circuit
- Powergood Output for Each Channel
- OCL/OVP/UVP/UVLO Protections (OVP Disable Option)
- Thermal Shutdown (Non-Latch)
- Output Discharge Function (Disable Option)
- Integrated Boot Strap MOSFET Switch
- QFN-32 (RTV/RSN) Package

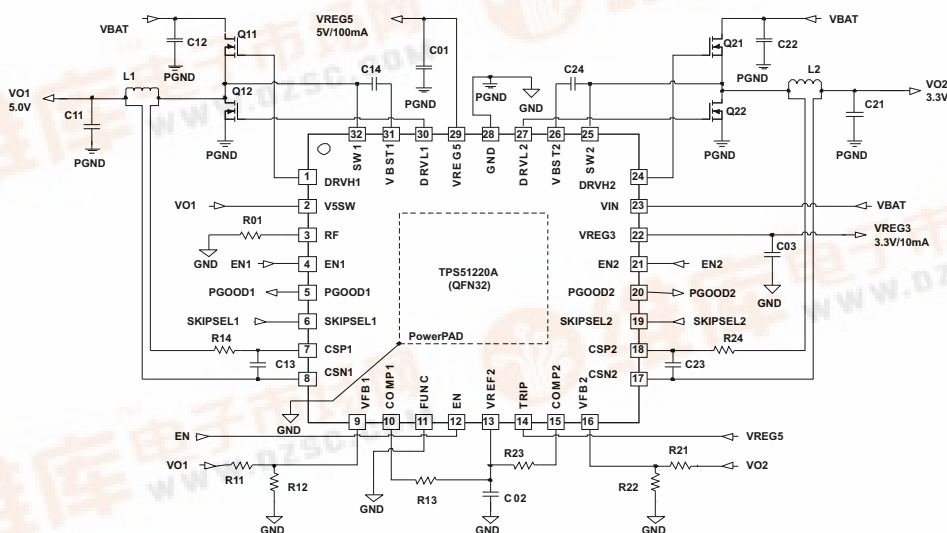
APPLICATIONS

- Notebook Computer System and I/O Bus
- Point of Load in LCD TV, MFP

DESCRIPTION

The TPS51220A is a dual synchronous buck regulator with two LDOs. It is optimized for 5-V/3.3-V system controller, enabling designers to cost effectively complete 2-cell to 4-cell notebook system power supply. The TPS51220A supports high efficiency, fast transient response, and 99% duty cycle operation. It supports supply input voltage ranging from 4.5 V to 32 V, and output voltages from 1 V to 12 V. Two types of control schemes can be chosen depending on the application. Peak current mode supports stability operation with lower ESR capacitor and output accuracy. The D-CAP mode supports fast transient response. The high duty (99%) operation and the wide input/output voltage range supports flexible design for small mobile PCs and a wide variety of other applications. The fixed frequency can be adjusted from 200 kHz to 1 MHz by a resistor, and each channel runs 180° out-of-phase. The TPS51220A can also synchronize to the external clock, and the interleaving ratio can be adjusted by its duty. The TPS51220A is available in the 32-pin 5x5/4x4 QFN package and is specified from -40°C to 85°C.

TYPICAL APPLICATION CIRCUIT



Please be aware that an important notice concerning availability, standard warranty, and use in critical applications of Texas Instruments semiconductor products and disclaimers thereto appears at the end of this data sheet.

Out-Of-Audio, D-CAP, PowerPAD are trademarks of Texas Instruments.

PRODUCTION DATA information is current as of publication date. Products conform to specifications per the terms of the Texas Instruments standard warranty. Production processing does not necessarily include testing of all parameters.

Copyright © 2008–2010, Texas Instruments Incorporated



TPS51220A

SLUS897D DECEMBER 2008 REVISED FEBRUARY 2010

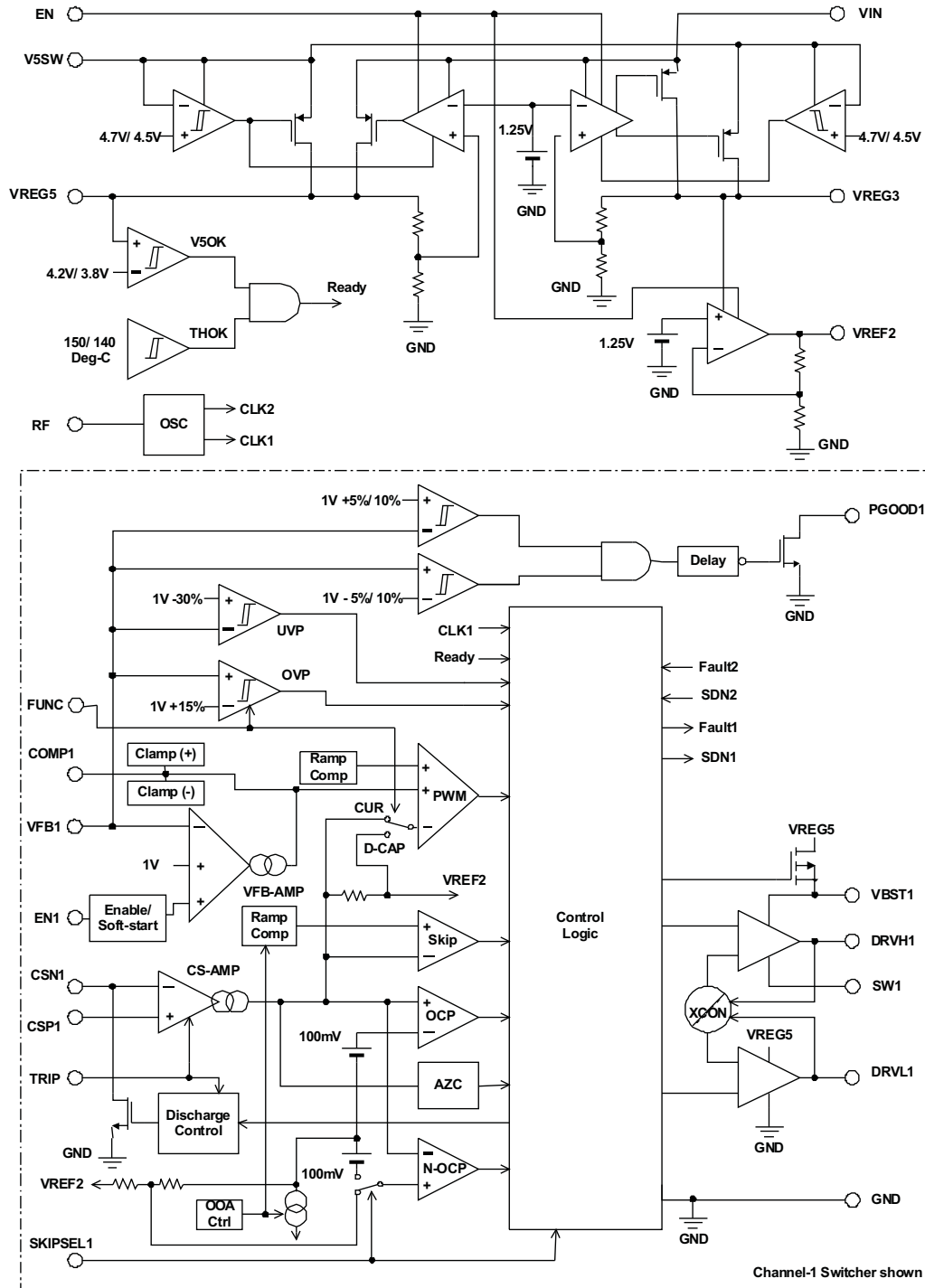
www.ti.com

[查询TPS51220A 供应链](#)



These devices have limited built-in ESD protection. The leads should be shorted together or the device placed in conductive foam during storage or handling to prevent electrostatic damage to the MOS gates.

FUNCTIONAL BLOCK DIAGRAM



ABSOLUTE MAXIMUM RATINGS⁽¹⁾

over operating free-air temperature range (unless otherwise noted)

		TPS51220A	UNIT
Input voltage range ⁽²⁾	VIN	-0.3 to 34	V
	VBST1, VBST2	-0.3 to 39	
	VBST1, VBST2 ⁽³⁾	-0.3 to 7	
	SW1, SW2	-7 to 34	
	CSP1, CSP2, CSN1, CSN2	-1 to 13.5	
	EN, EN1, EN2, VFB1, VFB2, TRIP, SKIPSEL1, SKIPSEL2, FUNC	-0.3 to 7	
	V5SW	-1 to 7	
	V5SW (to VREG5) ⁽⁴⁾	-7 to 7	
Output voltage range ⁽²⁾	DRVH1, DRVH2	-7 to 39	V
	DRVH1, DRVH2 ⁽³⁾	-0.3 to 7	V
	DRVL1, DRVL2, COMP1, COMP2, VREG5, RF, VREF2, PGOOD1, PGOOD2	-0.3 to 7	V
	VREG3	-0.3 to 3.6	V
T _J	Junction temperature	150	°C
T _{stg}	Storage temperature	-55 to 150	°C

- (1) Stresses beyond those listed under *Absolute Maximum Ratings* may cause permanent damage to the device. These are stress ratings only and functional operation of the device at these or any other conditions beyond those indicated under *recommended operating conditions* is not implied. Exposure to absolute-maximum-rated conditions for extended periods may affect device reliability.
- (2) All voltage values are with respect to the network ground terminal unless otherwise noted.
- (3) Voltage values are with respect to the corresponding SW terminal.
- (4) When EN is high and V5SW is grounded, or voltage is applied to V5SW when EN is low.

DISSIPATION RATINGS (2 oz. Trace and Copper Pad with Solder)

PACKAGE	T _A < 25°C POWER RATING (W)	DERATING FACTOR ABOVE T _A = 25°C (mW/°C)	T _A = 85°C POWER RATING (W)
32-pin RTV	1.7	17	0.7
32-pin RSN	2.3	23	0.9

RECOMMENDED OPERATING CONDITIONS

		MIN	TYP	MAX	UNIT
Supply voltage	VIN	4.5		32	V
	V5SW	-0.8		6	
I/O voltage	VBST1, VBST2	-0.1		37	V
	DRVH1, DRVH2	-4.		37	
	DRVH1, DRVH2 (wrt SW1, 2)	-0.1		6	
	DRVH1, DRVH2 (negative overshoot -6 V for t < 20% duration of the switching period)	-6		37	
	SW1, SW2	-4.		32	
	SW1, SW2 (negative overshoot -6 V for t < 20% duration of the switching period)	-6		32	
	CSP1, CSP2, CSN1, CSN2	-0.8		13	
	EN, EN1, EN2, VFB1, VFB2, TRIP, DRVL1, DRVL2, COMP1, COMP2, VREG5, RF, VREF2, PGOOD1, PGOOD2, SKIPSEL1, SKIPSEL2, FUNC	-0.1		6	
VREG3	-0.1		3.5		
T _A	Operating free-air temperature	-40		85	°C

TPS51220A

SLUS897D DECEMBER 2008 REVISED FEBRUARY 2010

www.ti.com
[查询TPS51220A 供货情况](#)

ORDERING INFORMATION

T _A	PACKAGE ⁽¹⁾	PINS	ORDERABLE DEVICE NUMBER	TRANSPORT MEDIA	QUANTITY	ECO PLAN
-40°C to 85°C	Plastic Quad Flat Pack (QFN)	32	TPS51220ARTVT	Tape and Reel	250	Green (RoHS and no Sb/Br)
			TPS51220ARTVR		3000	
			TPS51220ARSNT		250	
			TPS51220ARSNR		3000	

(1) For the most current package and ordering information, see the *Package Option Addendum* at the end of this document, or see the TI website at www.ti.com.

ELECTRICAL CHARACTERISTICS

over operating free-air temperature range, EN = 3.3V, VIN = 12V, V5SW = 5V (unless otherwise noted)

PARAMETER		TEST CONDITIONS	MIN	TYP	MAX	UNIT
SUPPLY CURRENT						
I _{VINSDN}	VIN shutdown current	VIN shutdown current, T _A = 25°C, No Load, EN = 0V, V5SW = 0 V		7	15	μA
I _{VINSTBY}	VIN Standby Current	VIN standby current, T _A = 25°C, No Load, EN1 = EN2 = V5SW = 0 V		80	120	μA
I _{VBATSTBY}	VBAT Standby Current	Vbat standby current, T _A = 25°C, No Load SKIPSEL2 = 2V, EN2 = open, EN1 = V5SW = 0V ⁽¹⁾		500		μA
I _{V5SW}	V5SW Supply Current	V5SW current, T _A = 25°C, No Load, ENx = 5V, VFBx = 1.05 V				
			TRIP = 5 V	0.8		
				0.9		mA
VREF2 OUTPUT						
V _{VREF2}	VREF2 Output Voltage	I _(VREF2) < ±10 μA, T _A = 25°C	1.98	2.00	2.02	V
		I _(VREF2) < ±100 μA, 4.5V < VIN < 32 V	1.97	2.00	2.03	
VREG3 OUTPUT						
V _{VREG3}	VREG3 Output Voltage	V5SW = 0 V, I _(VREG3) = 0 mA, T _A = 25°C	3.279	3.313	3.347	V
		V5SW = 0 V, 0 mA < I _(VREG3) < 10 mA, 5.5 V < VIN < 32 V	3.135	3.300	3.400	
I _{VREG3}	VREG3 Output Current	VREG3 = 3 V	10	15	20	mA
VREG5 OUTPUT						
V _{VREG5}	VREG5 Output Voltage	V5SW = 0 V, I _(VREG5) = 0 mA, T _A = 25°C	4.99	5.04	5.09	V
		V5SW = 0 V, 0 mA < I _(VREG5) < 100 mA, 6 V < VIN < 32 V	4.90	5.03	5.15	
		V5SW = 0 V, 0 mA < I _(VREG5) < 100 mA, 5.5 V < VIN < 32 V	4.50	5.03	5.15	
I _{VREG5}	VREG5 Output Current	V5SW = 0 V, VREG5 = 4.5 V	100	150	200	mA
		V5SW = 5 V, VREG5 = 4.5 V	200	300	400	
V _{THV5SW}	Switchover Threshold	Turning on	4.55	4.7	4.8	V
		Hysteresis	0.15	0.20	0.25	
t _{dV5SW}	Switchover Delay	Turning on		7.7		ms
R _{V5SW}	5V SW On-Resistance	I _(VREG5) = 100 mA		0.5		Ω
OUTPUT						
V _{VFB}	VFB Regulation Voltage Tolerance	T _A = 25°C, No Load	0.9925	1.000	1.0075	V
		T _A = -40°C to 85°C, No Load	0.990	1.000	1.010	
I _{VFB}	VFB Input Current	VFBx = 1.05 V, COMPx = 1.8 V, T _A = 25°C	-50		50	nA
R _{DISCHG}	CSNx Discharge Resistance	ENx = 0 V, CSNx = 0.5 V, T _A = 25°C		20	40	Ω

(1) Specified by design. Detail external condition follows application circuit of [Figure 57](#).

ELECTRICAL CHARACTERISTICS (continued)

over operating free-air temperature range, EN = 3.3V, VIN = 12V, V5SW = 5V (unless otherwise noted)

PARAMETER		TEST CONDITIONS	MIN	TYP	MAX	UNIT
VOLTAGE TRANSCONDUCTANCE AMPLIFIER						
g_{Mv}	Gain	$T_A = 25^\circ\text{C}$		500		μS
V_{ID}	Differential Input Voltage Range		-30		30	mV
$I_{COMPSINK}$	COMP Maximum Sink Current	COMPx = 1.8 V	$T_A = 0$ to 85°C	27	33	μA
			$T_A = -40$ to 85°C	22	33	μA
$I_{COMPSRC}$	COMP Maximum Source Current	COMPx = 1.8 V		-33	-43	μA
V_{COMP}	COMP Clamp Voltage		2.18	2.22	2.26	V
V_{COMPN}	COMP Negative Clamp Voltage		1.73	1.77	1.81	V
CURRENT AMPLIFIER						
G_C	Gain	TRIP = 0V/2V, CSNx = 5V, $T_A = 25^\circ\text{C}$ ⁽²⁾		3.333		
		TRIP = 3.3V/5V, CSNx = 5V, $T_A = 25^\circ\text{C}$ ⁽²⁾		1.667		
V_{IC}	Common mode Input Voltage Range		0		13	V
V_{ID}	Differential Input Voltage Range	$T_A = 25^\circ\text{C}$	-75		75	mV
POWERGOOD						
V_{THPG}	PG threshold	PG in from lower	92.5%	95%	97.5%	
		PG in from higher	102.5%	105%	107.5%	
		PG hysteresis		5%		
I_{PG}	PG sink current	PGOOD = 0.5 V		5		mA
$I_{PG(LK)}$	PG leak current	PGOOD = 5 V		0	1	μA
t_{PGDLY}	PGOOD delay	Delay for PG in	0.8	1.0	1.2	ms
SOFTSTART						
t_{SSDYL}	Soft Start Delay	Delay for Soft Start, ENx = Hi to SS-ramp starts		200		μs
t_{SS}	Soft Start Time	Internal Soft Start		960		μs
FREQUENCY AND DUTY CONTROL						
f_{SW}	Switching Frequency	$R_F = 330\text{ k}\Omega$	273	303	333	kHz
V_{THRF}	RF Threshold	Lo to Hi	0.7	1.3	2	V
		Hysteresis		0.2		V
f_{SYNC}	Sync Input Frequency Range ⁽²⁾		200		1000	kHz
$t_{ON(min)}$	Minimum On Time	$V_{(DRVH)} = 90\%$ to 10% , No Load, CCM/ OOA ⁽²⁾		120		ns
		$V_{(DRVH)} = 90\%$ to 10% , No Load, Auto-skip		160	250	ns
$t_{OFF(min)}$	Minimum Off Time	$V_{(DRVH)} = 10\%$ to 90% , No Load		290	400	ns
t_D	Dead time	DRVH-off to DRVL-on	10	30	50	ns
		DRVL-off to DRVH-on	30	40	70	ns
V_{DTH}	DRVH-off threshold	DRVH to GND ⁽²⁾		1		V
V_{DTL}	DRVL-off threshold	DRVL to GND ⁽²⁾		1		V

(2) Specified by design. Not production tested.

TPS51220A

SLUS897D DECEMBER 2008 / REVISED FEBRUARY 2010

www.ti.com

ELECTRICAL CHARACTERISTICS (continued)

over operating free-air temperature range, EN = 3.3V, VIN = 12V, V5SW = 5V (unless otherwise noted)

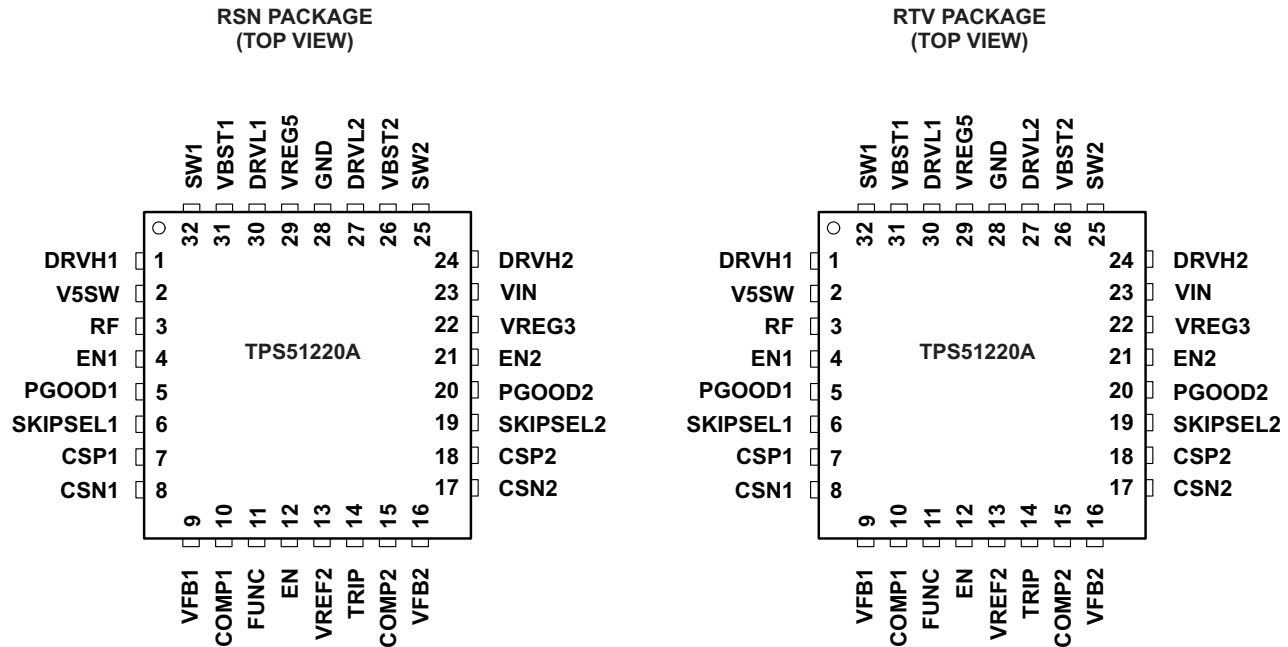
PARAMETER		TEST CONDITIONS	MIN	TYP	MAX	UNIT	
CURRENT SENSE							
V _{OCL-ULV}	Current limit threshold (ultra-low voltage)	TRIP=0V/ 2V, 2V<CSNx<12.6V	RTV package, T _A = 0 to 85°C	28	31	35	mV
			RSN package, T _A = 0 to 85°C	28	31	34	
		TRIP=0V/ 2V, 0.95V<CSNx<12.6V	T _A = -40 to 85°C	27	31	37	
			T _A = 0 to 85°C	27	31	36	
V _{OCL-LV}	Current limit threshold (low voltage)	TRIP=3.3V/ 5V, 2V<CSNx<12.6V	T _A = 0 to 85°C	56	60	65	mV
			T _A = -40 to 85°C	55	60	68	
		TRIP=3.3V/ 5V, 0.95V<CSNx<12.6V	T _A = 0 to 85°C	55	60	67	
			T _A = -40 to 85°C	54	60	72	
V _{ZCAJ}	Auto-Zero cross adjustable offset range	0.95V < CSNx < 12.6V, Auto-skip	Positive		5	mV	
		Negative		-5			
V _{ZC}	Zero cross detection comparator Offset	0.95V < CSNx < 12.6V, OOA	-4	0	4	mV	
V _{OCLN-ULV}	Negative current limit threshold (ultra-low voltage)	TRIP = 0V/2V, 0.95V < CSNx < 12.6V	T _A = 0 to 85°C	-23	-31	-40	mV
			T _A = -40 to 85°C	-22	-31	-44	
V _{OCLN-LV}	Negative current limit threshold (low voltage)	TRIP = 3.3V/5V, 0.95V < CSNx < 12.6V	T _A = 0 to 85°C	-50	-60	-73	mV
			T _A = -40 to 85°C	-49	-60	-77	
OUTPUT DRIVERS							
R _{DRVH}	DRVH resistance	Source, V _(VBST-DRVH) = 0.1 V		1.7	5	Ω	
		Sink, V _(DRVH-SW) = 0.1 V		1	3		
R _{DRVL}	DRVL resistance	Source, V _(VREG5-DRVL) = 0.1 V		1.3	4	Ω	
		Sink, V _(DRVL-GND) = 0.1 V		0.7	2		
UVP, OVP AND UVLO							
V _{OVP}	OVP Trip Threshold	OVP detect	110%	115%	120%		
t _{OVPDLY}	OVP Prop Delay			1.5		μs	
V _{UVP}	UVP Trip Threshold	UVP detect	65%	70%	73%		
t _{UVPDLY}	UVP Delay		0.8	1	1.2	ms	
V _{UVREF2}	VREF2 UVLO Threshold	Wake up	1.7	1.8	1.9	V	
		Hysteresis	75	100	125	mV	
V _{UVREG3}	VREG3 UVLO Threshold	Wake up	3	3.1	3.2	V	
		Hysteresis	0.10	0.15	0.20		
V _{UVREG5}	VREG5 UVLO Threshold	Wake up	4.1	4.2	4.3	V	
		Hysteresis	0.35	0.40	0.44	V	

ELECTRICAL CHARACTERISTICS (continued)

over operating free-air temperature range, EN = 3.3V, VIN = 12V, V5SW = 5V (unless otherwise noted)

PARAMETER		TEST CONDITIONS	MIN	TYP	MAX	UNIT
INTERFACE AND LOGIC THRESHOLD						
V _{EN}	EN Threshold	Wake up	0.8	1	1.2	V
		Hysteresis	0.1	0.2	0.3	
I _{ENLK}	EN leak current	EN = 0 V, or EN = 3.3 V	-1		1	μA
V _{EN12}	EN1/EN2 Threshold	Wake up	0.45	0.50	0.55	V
		Hysteresis	0.1	0.2	0.3	
V _{EN12SS}	EN1/EN2 SS Start Threshold	SS-ramp start threshold at external soft start		1		V
V _{EN12SSEND}	EN1/EN2 SS End Threshold	SS-End threshold at external soft start ⁽³⁾		2		V
I _{EN12}	EN1/EN2 Source Current	VEN1/EN2 = 0V	1.6	2	2.4	μA
V _{SKIPSEL}	SKIPSEL1/SKIPSEL2 Setting Voltage	Continuous			1.5	V
		Auto Skip	1.9		2.1	
		OOA Skip (min 1/8 Fsw)	3.2		3.4	
		OOA Skip (min 1/16 Fsw)	3.8			
V _{TRIP}	TRIP Setting Voltage	V _(OCL-ULV) , Discharge ON			1.5	V
		V _(OCL-ULV) , Discharge OFF	1.9		2.1	
		V _(OCL-LV) , Discharge OFF	3.2		3.4	
		V _(OCL-LV) , Discharge ON	3.8			
V _{FUNC}	FUNC Setting Voltage	Current mode, OVP enable			1.5	V
		D-CAP mode, OVP disable	1.9		2.1	
		D-CAP mode, OVP enable	3.2		3.4	
		Current mode, OVP disable	3.8			
I _{TRIP}	TRIP Input Current	TRIP = 0 V	-1		1	μA
		TRIP = 5 V	-1		1	
I _{SKIPSEL}	SKIPSEL Input Current	SKIPSELx = 0 V	-0.5		0.5	μA
		SKIPSELx = 5 V	-0.5		0.5	
BOOT STRAP SW						
V _{FBST}	Forward Voltage	V _{VREG5-VBST} , I _F = 10 mA, T _A = 25°C		0.10	0.20	V
I _{BSTLK}	VBST Leakage Current	V _{VBST} = 37 V, V _{SW} = 32 V		0.01	1.5	μA
THERMAL SHUTDOWN						
T _{SDN}	Thermal SDN Threshold	Shutdown temperature ⁽³⁾		150		°C
		Hysteresis ⁽³⁾		10		

(3) Specified by design. Not production tested.

DEVICE INFORMATION

PIN FUNCTIONS

PIN		I/O	DESCRIPTION
NAME	NO.		
DRVH1	1	O	High-side MOSFET gate driver outputs. Source 1.7 Ω, sink 1.0 Ω, SW-node referenced floating driver. Drive voltage corresponds to VBST to SW voltage.
DRVH2	24		
SW2	25	I/O	High-side MOSFET gate driver returns.
SW1	32		
VREG3	22	O	Always alive 3.3 V, 10 mA low dropout linear regulator output. Bypass to (signal) GND with more than 1-μF ceramic capacitance. Runs from VIN supply or from VREG5 when it is switched over to V5SW input.
EN1	4	I	Channel 1 and channel 2 SMPS Enable Pins. When turning on, apply greater than 0.55 V and less than 6 V, or leave floating. Connect to GND to disable. Adjustable soft-start capacitance to be attached here.
EN2	21		
PGOOD1	5	O	Powergood window comparator outputs for channel 1 and channel 2. The recommended applied voltage should be less than 6 V, and the recommended pull-up resistance value is from 100 kΩ to 1 MΩ.
PGOOD2	20		
SKIPSEL1	6	I	Skip mode selection pin. GND: Continuous conduction mode VREF2: Auto Skip VREG3: OOA Auto Skip, maximum 7 skips (suitable for $f_{sw} < 400\text{kHz}$) VREG5: OOA Auto Skip, maximum 15 skips (suitable for equal to or greater than 400kHz)
SKIPSEL2	19		
CSP1	7	I/O	Current sense comparator inputs (+). An RC network with high quality X5R or X7R ceramic capacitor should be used to extract voltage drop across DCR. 0.1-μF is a good value to start the design. See the current sensing scheme section for more details.
CSP2	18		
CSN1	8	I	Current sense comparator inputs (-). See the current sensing scheme section. Used as power supply for the current sense circuit for 5V or higher output voltage setting. Also, used for output discharge terminal.
CSN2	17		
VFB1	9	I	SMPS voltage feedback Inputs. Connect the feedback resistors divider, and should be referred to (signal) GND.
VFB2	16		
COMP1	10	I	Loop compensation pin for current mode (error amplifier output). Connect R (and C if required) from this pin to VREF2 for proper loop compensation with current mode operation. Ramp compensation adjustable pin for D-CAP mode, connect R from this pin to VREF2. 10 kΩ is a good value to start the design. 6 kΩ to 20 kΩ can be chosen. See the D-CAP MODE section for more details.
COMP2	15		
RF	3	I/O	Frequency setting pin. Connect a frequency setting resistor to (signal) GND. Connect to an external clock for synchronization.

PIN FUNCTIONS (continued)

PIN		I/O	DESCRIPTION
NAME	NO.		
FUNC	11	I	Control architecture and OVP functions selection pin. GND: Current mode, OVP enable VREF2: D-CAP mode, OVP disable VREG3: D-CAP mode, OVP enable VREG5: Current mode, OVP disable
VREF2	13	O	2-V reference output. Bypass to (signal) GND with 0.22- μ F of ceramic capacitance.
TRIP	14	I	Overcurrent trip level and discharge mode selection pin. GND: $V_{(OCL-ULV)}$, discharge on VREF2: $V_{(OCL-ULV)}$, discharge off VREG3: $V_{(OCL-LV)}$, discharge off VREG5: $V_{(OCL-LV)}$, discharge on
EN	12	I	VREF2 and VREG5 linear regulators enable pin. When turning on, apply greater than 1.2 V and less than 6 V. Connect to GND to disable.
VBST1	31	I	Supply inputs for high-side N-channel FET driver (boot strap terminal). Connect a capacitor (0.1- μ F or greater is recommended) from this pin to respective SW terminal. Additional SB diode from VREG5 to this pin is an optional.
VBST2	26		
DRVL1	30	O	Low-side MOSFET gate driver outputs. Source 1.3 Ω , sink 0.7 Ω , and GND referenced driver.
DRVL2	27		
V5SW	2	I	VREG5 switchover power supply input pin. When EN1 is high, PGOOD1 indicates GOOD and V5SW voltage is higher than 4.8 V, switch-over function is enabled. Note: When switch-over is enabled, VREG5 output voltage is approximately equal to the V5SW input voltage.
VREG5	29	O	5-V, 100-mA low dropout linear regulator output. Bypass to (power) GND using a 10- μ F ceramic capacitor. Runs from VIN supply. Internally connected to VBST and DRVL. Shuts off with EN. Switches over to V5SW when 4.8 V or above is provided. Note: When switch-over (see above V5SW) is enabled, VREG5 output voltage is approximately equal to V5SW input voltage.
VIN	23	I	Supply input for 5-V and 3.3-V linear regulator. Typically connected to VBAT.
GND	28	–	Ground

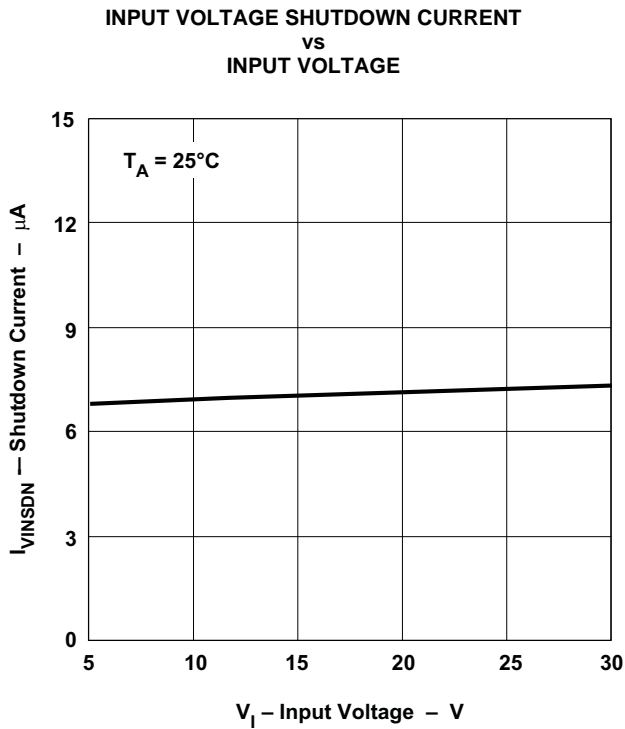
TYPICAL CHARACTERISTICS


Figure 1.

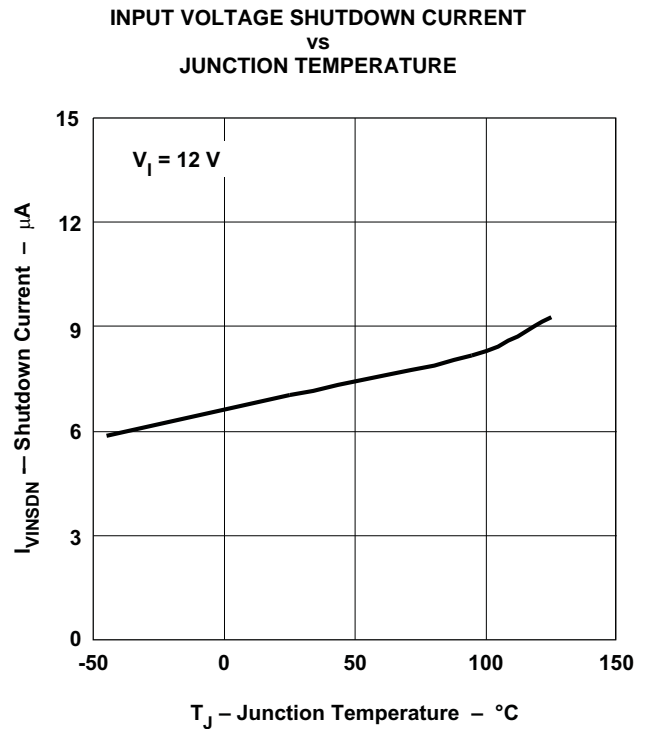


Figure 2.

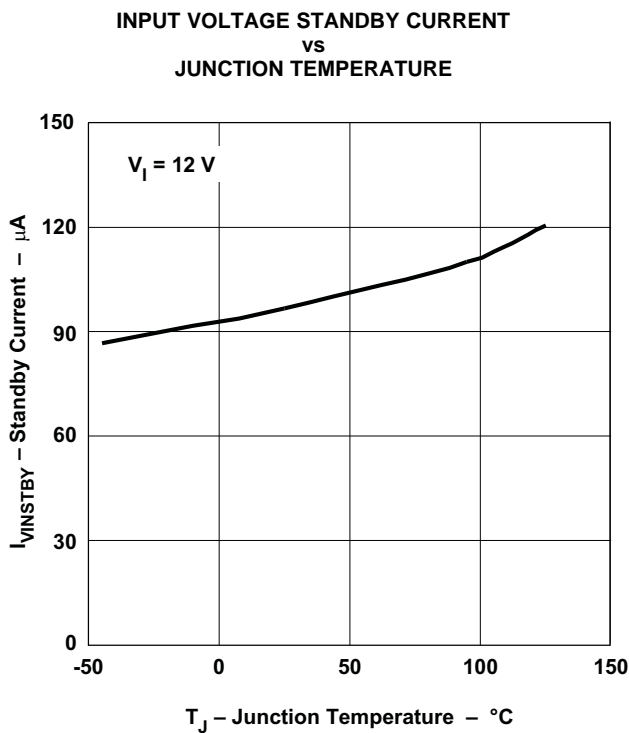


Figure 3.

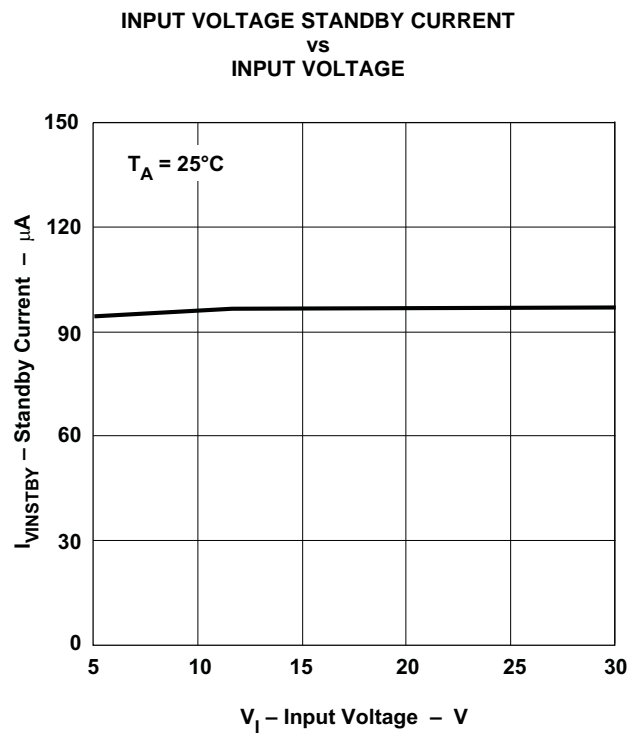


Figure 4.

TYPICAL CHARACTERISTICS (continued)

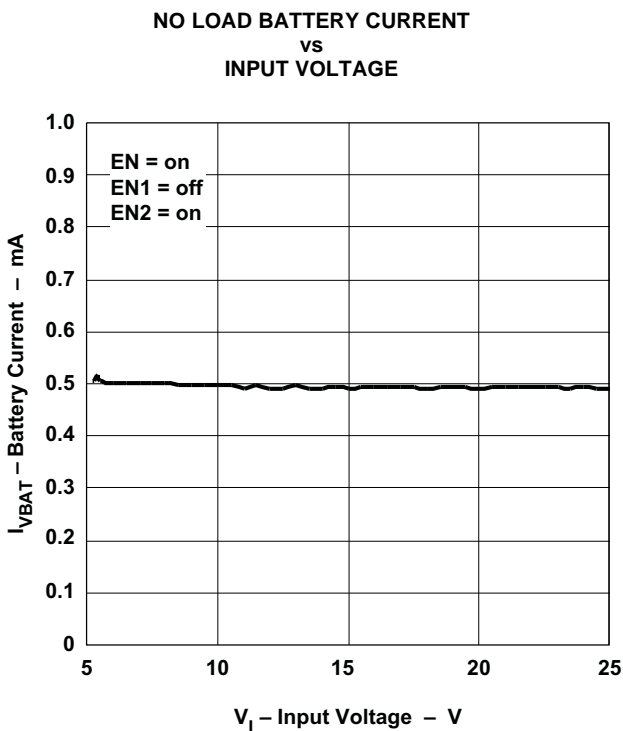


Figure 5.

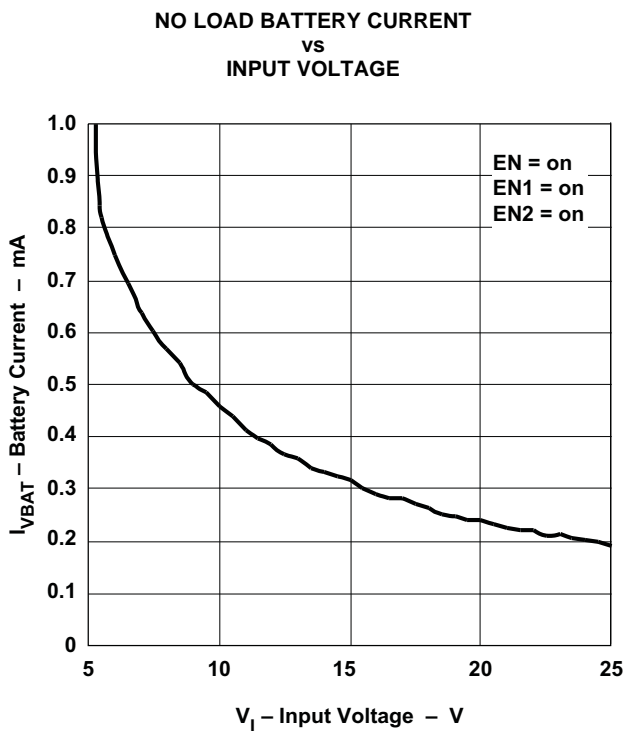


Figure 6.

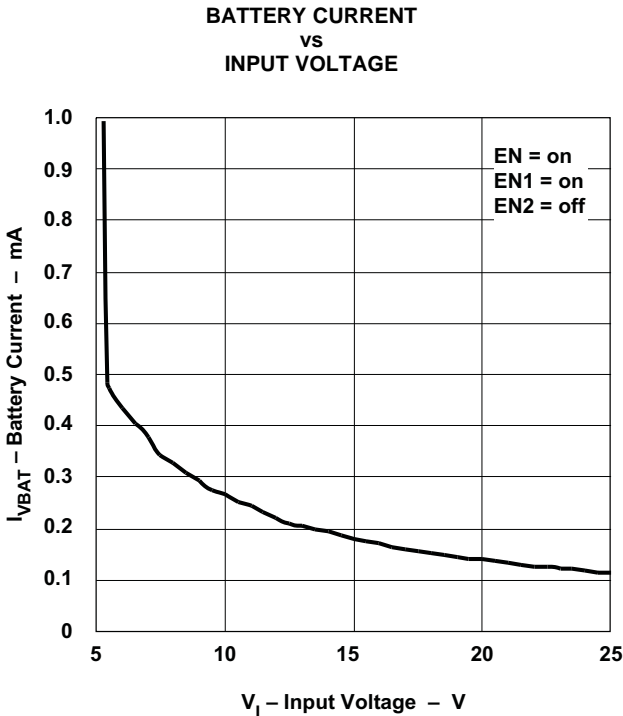


Figure 7.

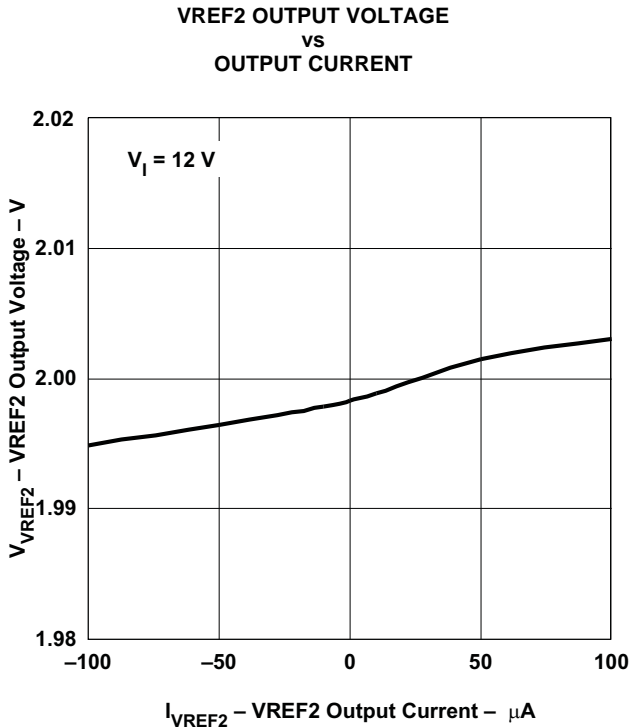


Figure 8.

TYPICAL CHARACTERISTICS (continued)

VREG3 OUTPUT VOLTAGE
VS
OUTPUT CURRENT

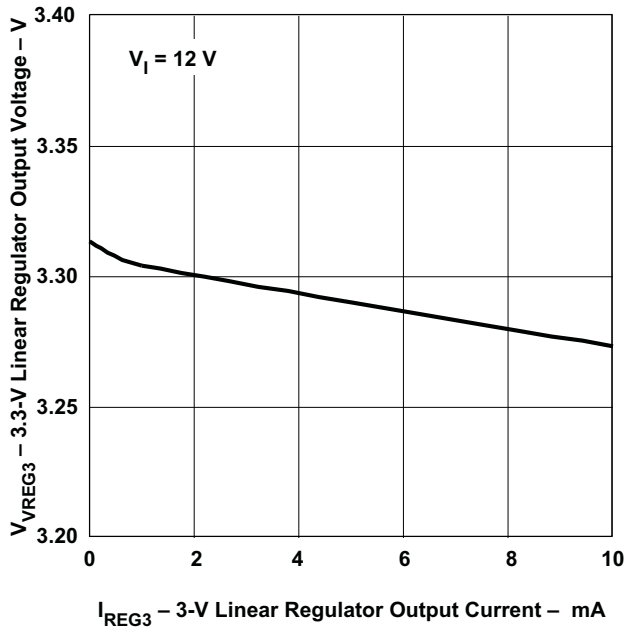


Figure 9.

VREG5 OUTPUT VOLTAGE
VS
OUTPUT CURRENT

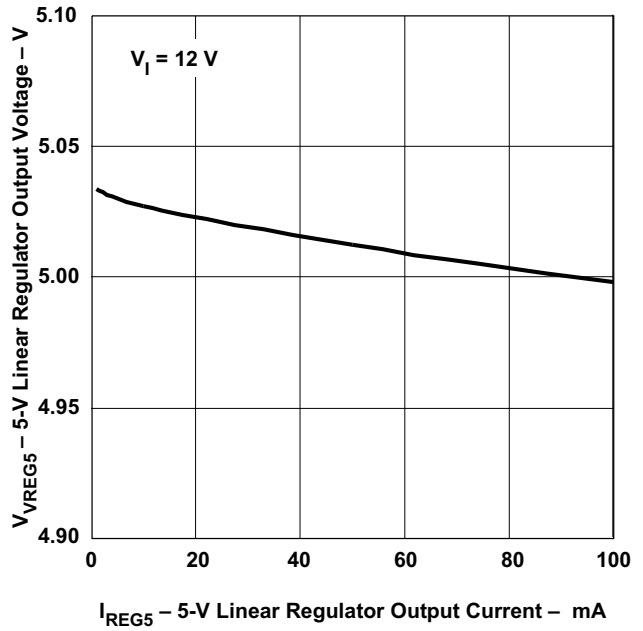


Figure 10.

SWITCHING FREQUENCY
VS
JUNCTION TEMPERATURE

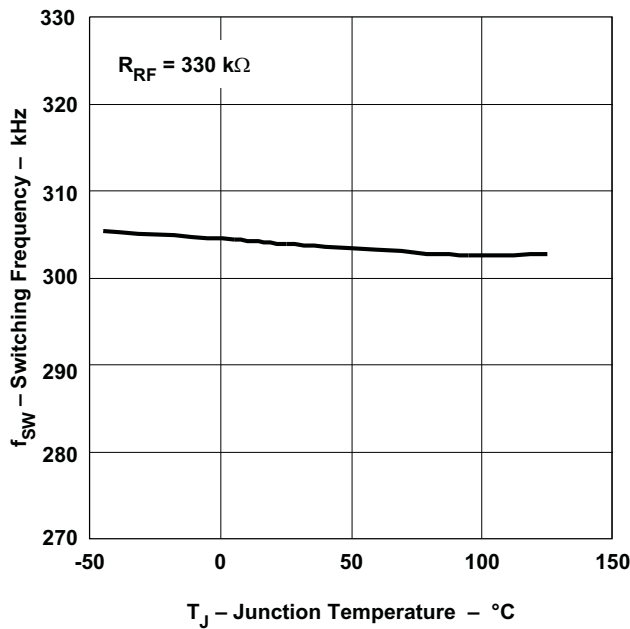


Figure 11.

FORWARD VOLTAGE OF BOOST SW
VS
JUNCTION TEMPERATURE

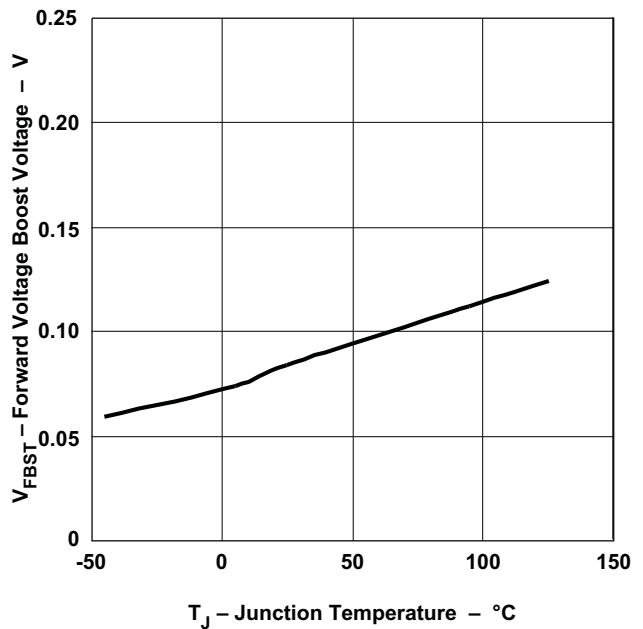


Figure 12.

TYPICAL CHARACTERISTICS (continued)

OVP/UVP THRESHOLD VOLTAGE
VS
JUNCTION TEMPERATURE

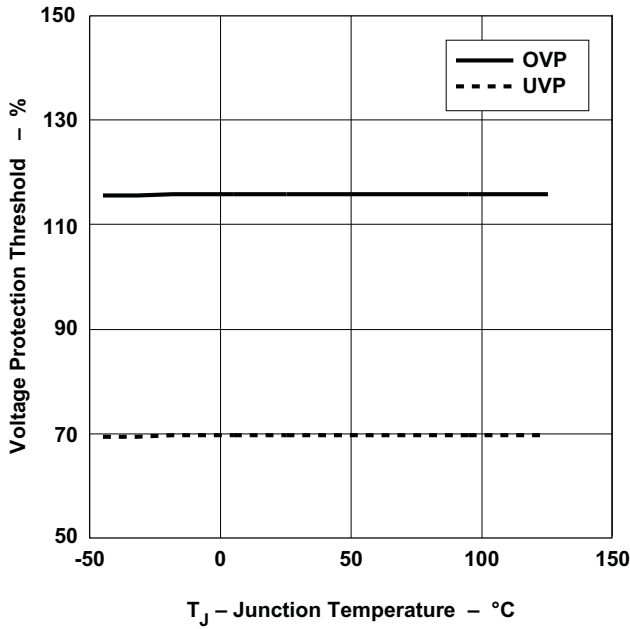


Figure 13.

VBST LEAKAGE CURRENT
VS
JUNCTION TEMPERATURE

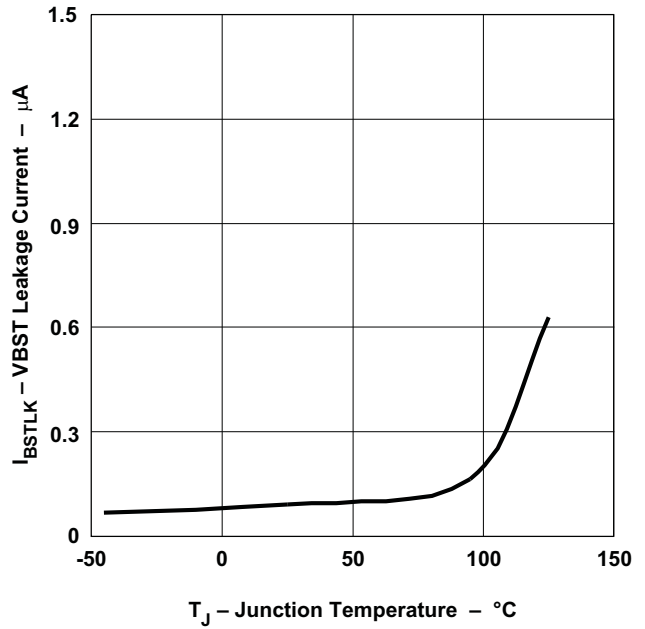


Figure 14.

CURRENT LIMIT THRESHOLD
VS
JUNCTION TEMPERATURE

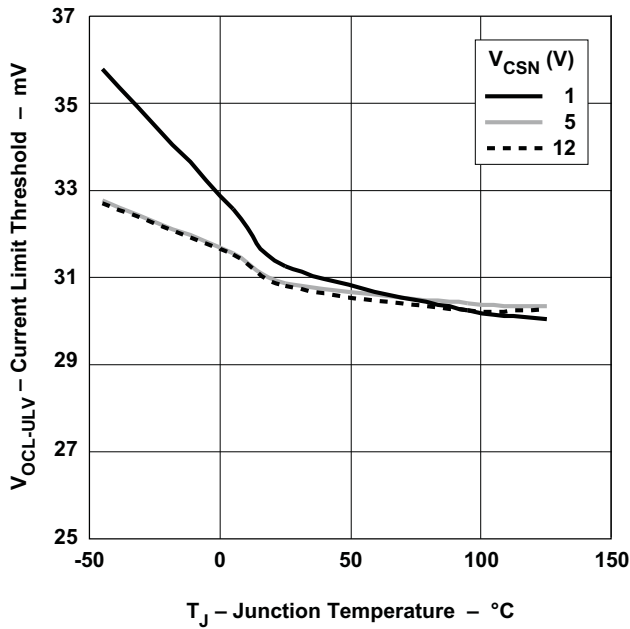


Figure 15.

CURRENT LIMIT THRESHOLD
VS
JUNCTION TEMPERATURE

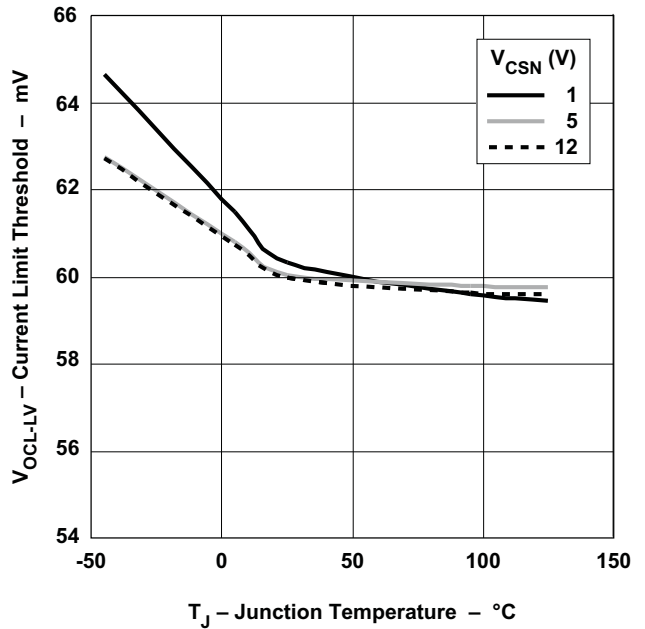


Figure 16.

TYPICAL CHARACTERISTICS (continued)

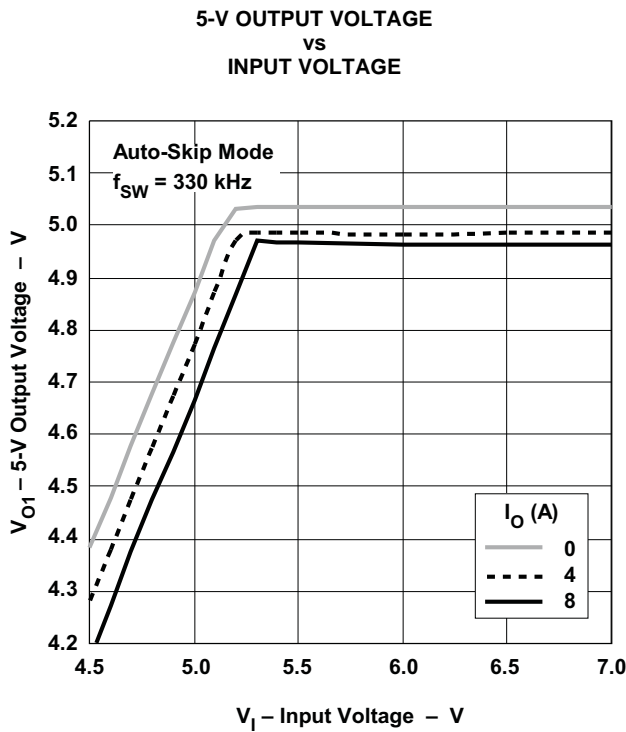


Figure 17.

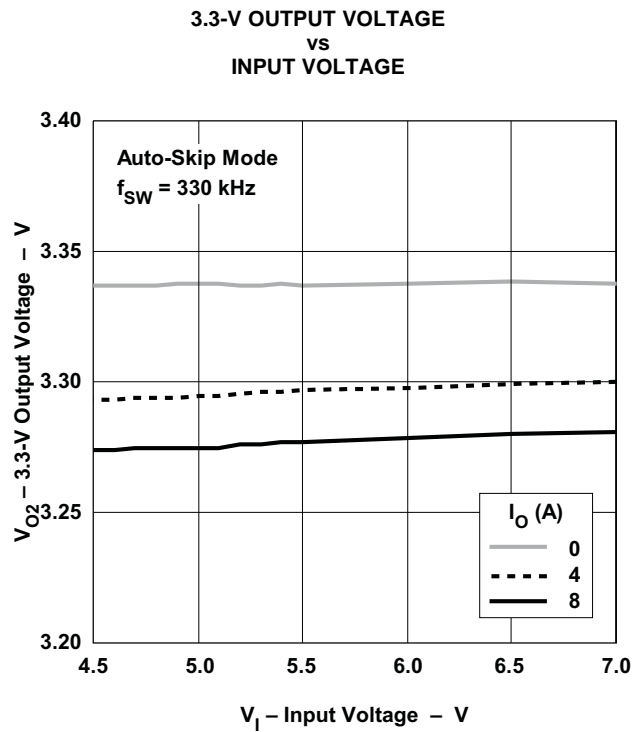


Figure 18.

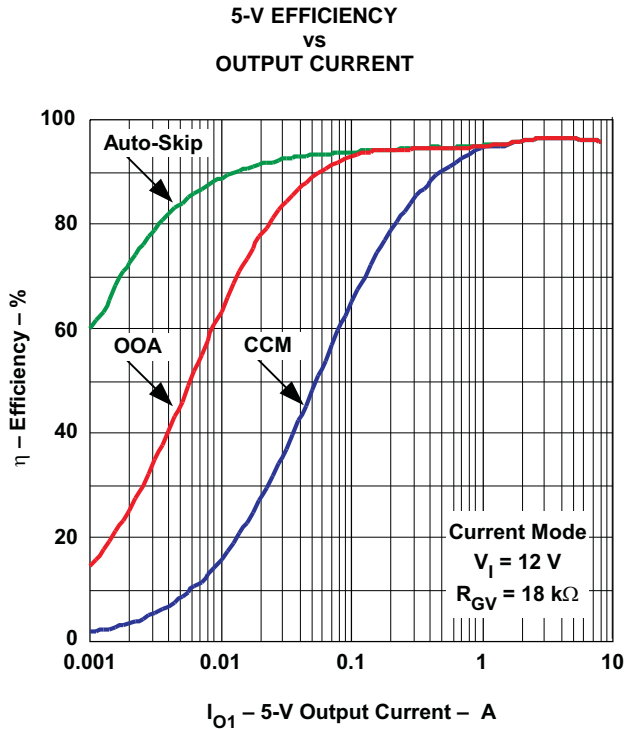


Figure 19.

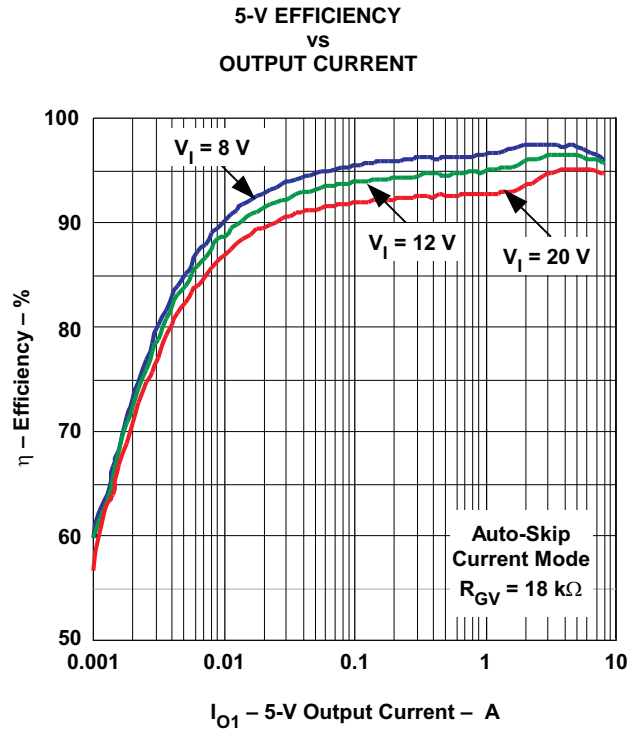


Figure 20.

TYPICAL CHARACTERISTICS (continued)

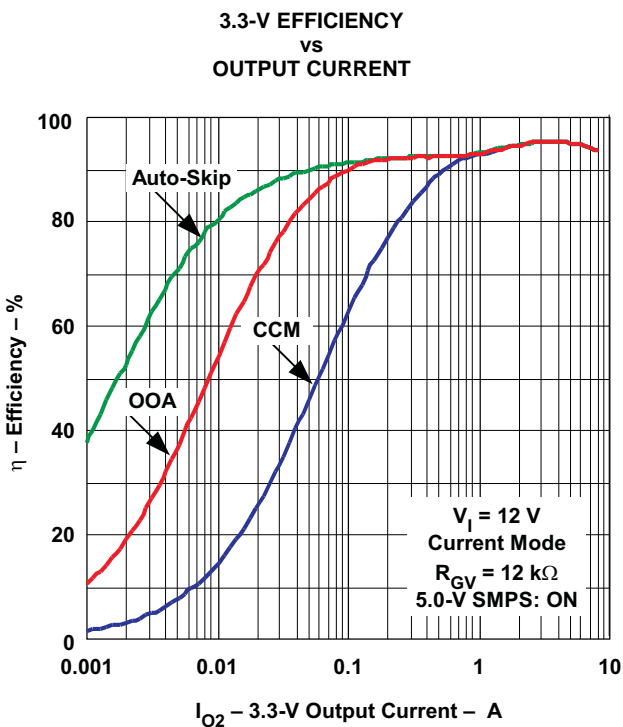


Figure 21.

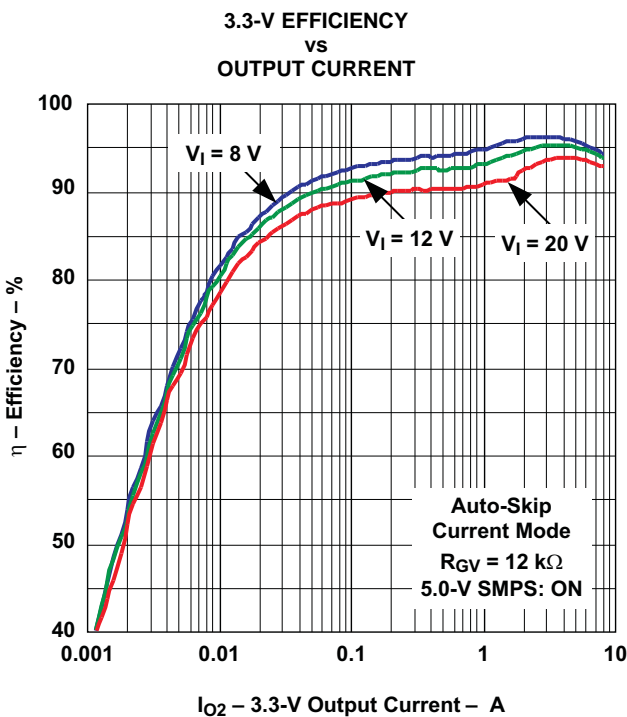


Figure 22.

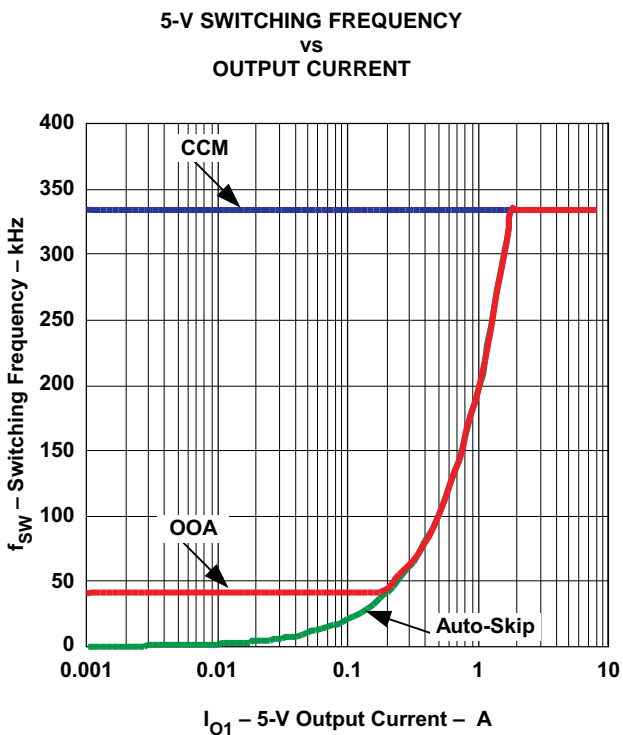


Figure 23.

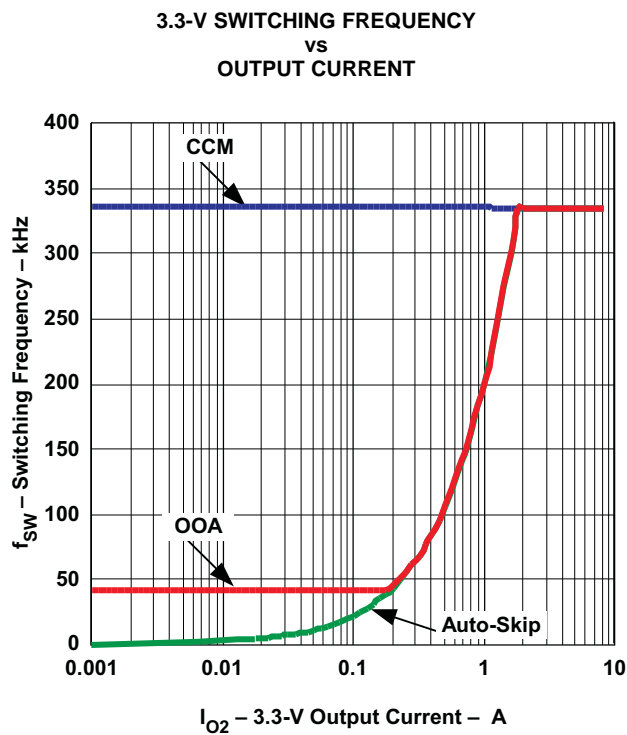


Figure 24.

TYPICAL CHARACTERISTICS (continued)

5-V OUTPUT VOLTAGE
vs
OUTPUT CURRENT

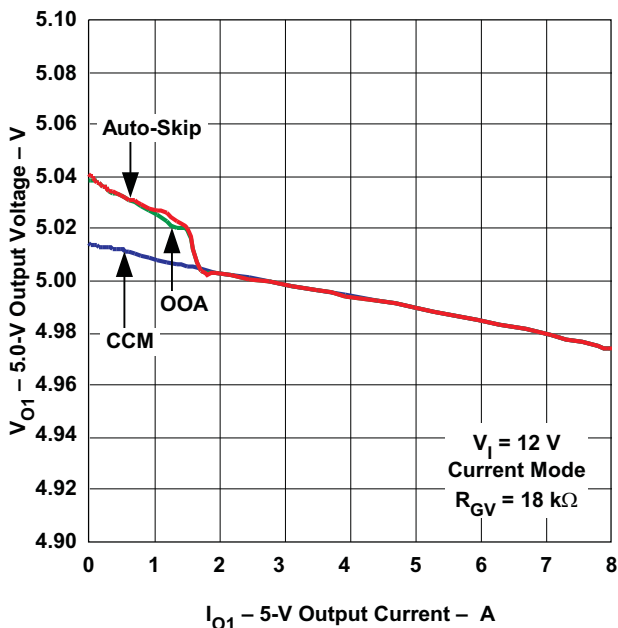


Figure 25.

3.3-V OUTPUT VOLTAGE
vs
OUTPUT CURRENT

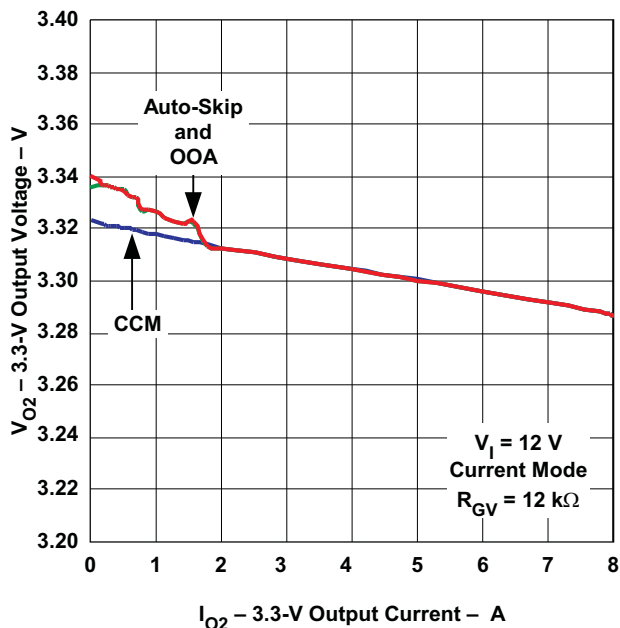


Figure 26.

5-V OUTPUT VOLTAGE
vs
OUTPUT CURRENT

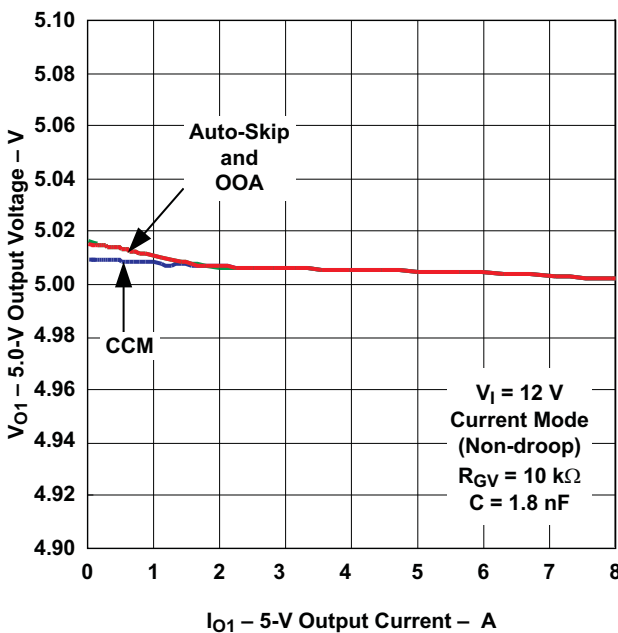


Figure 27.

3.3-V OUTPUT VOLTAGE
vs
OUTPUT CURRENT

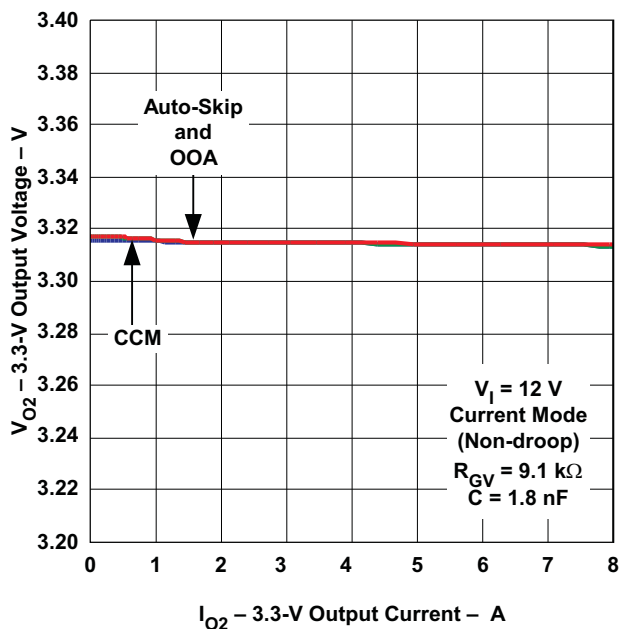


Figure 28.

TYPICAL CHARACTERISTICS (continued)

5-V OUTPUT VOLTAGE
VS
OUTPUT CURRENT

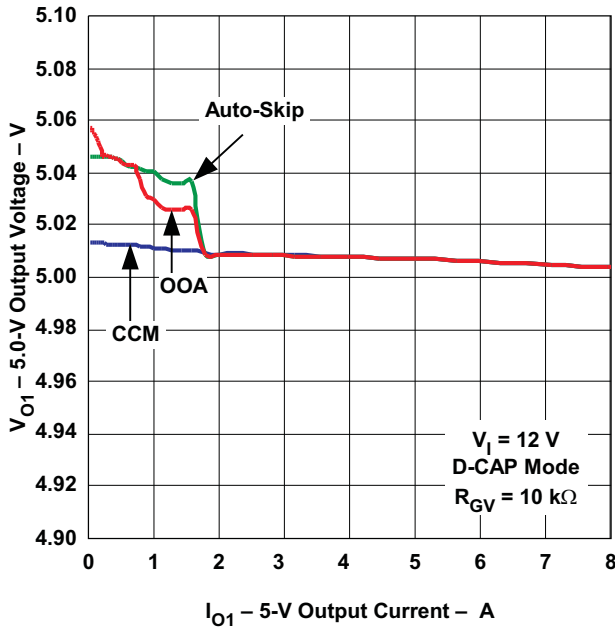


Figure 29.

3.3-V OUTPUT VOLTAGE
VS
OUTPUT CURRENT

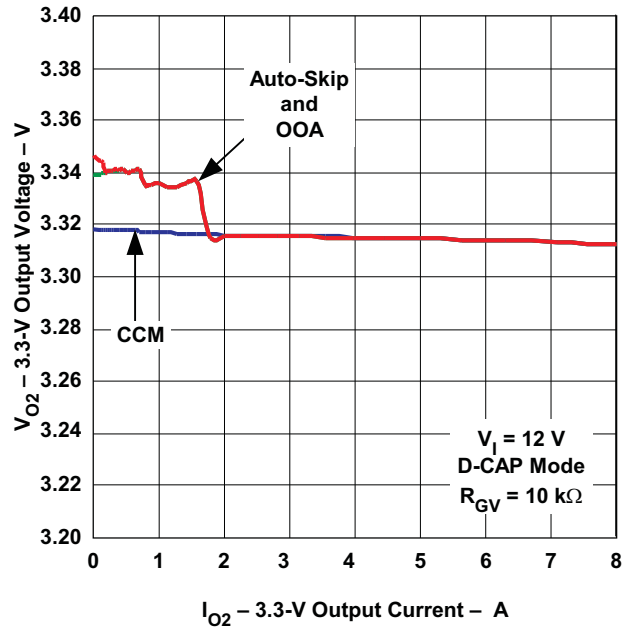


Figure 30.

5.0-V BODE-PLOT – GAIN AND PHASE
VS
FREQUENCY

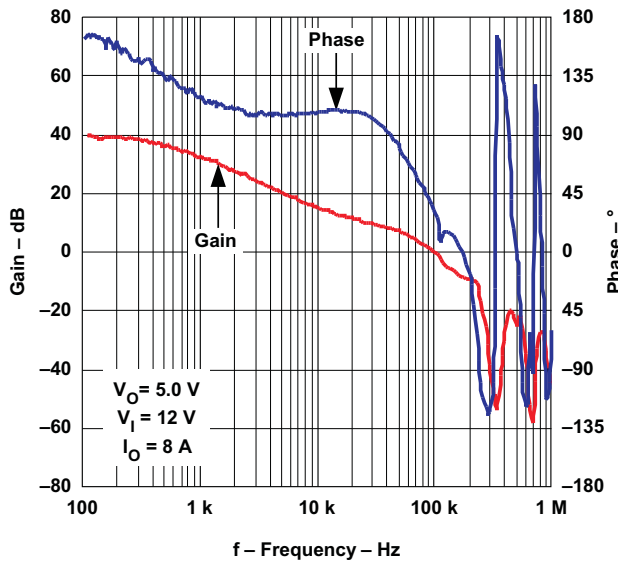


Figure 31.

3.3-V BODE-PLOT – GAIN AND PHASE
VS
FREQUENCY

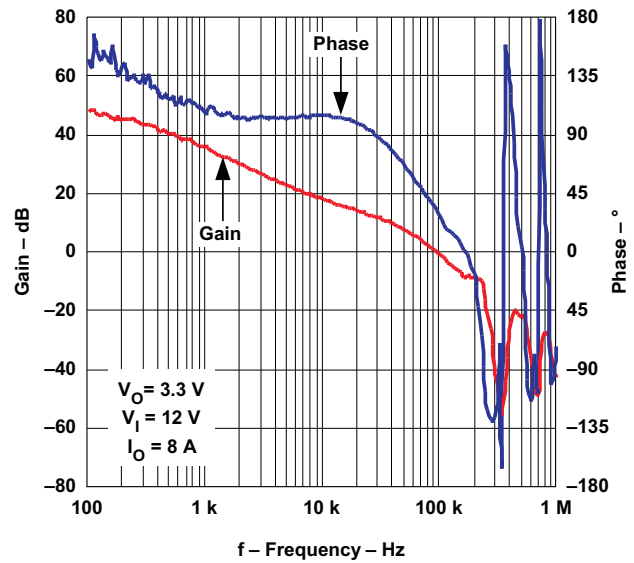


Figure 32.

[查询TPS51220A 供应商](#)

TYPICAL CHARACTERISTICS (continued)

5.0-V SWITCH-OVER WAVEFORMS

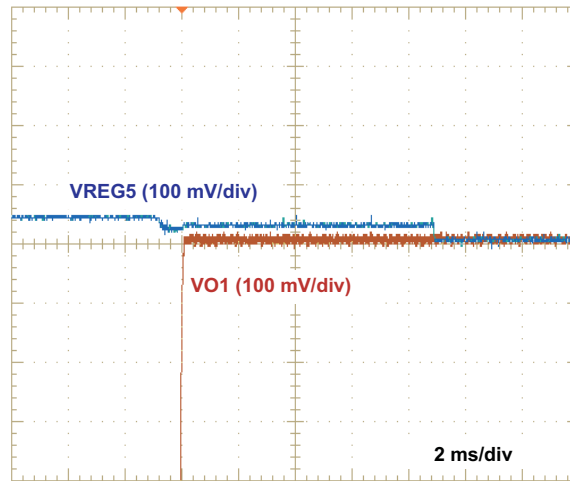


Figure 33.

TYPICAL CHARACTERISTICS

5.0-V START-UP WAVEFORMS

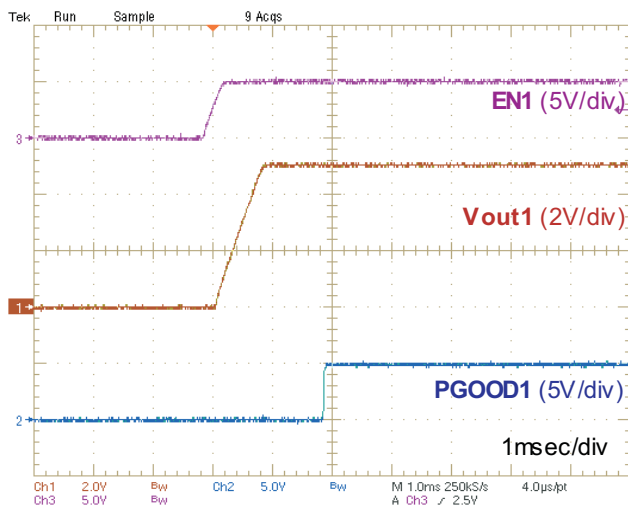


Figure 34.

3.3-V START-UP WAVEFORMS

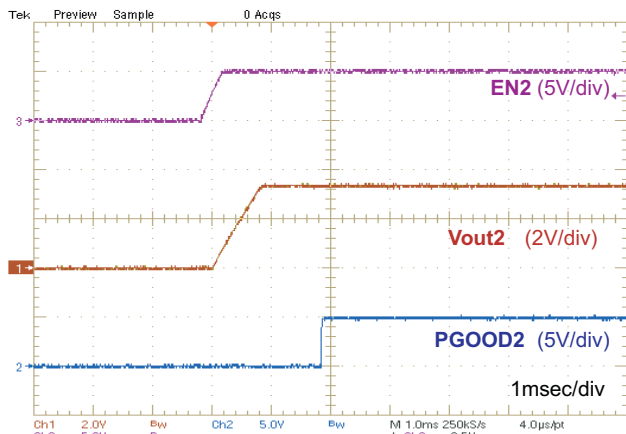


Figure 35.

5.0-V SOFT-STOP WAVEFORMS

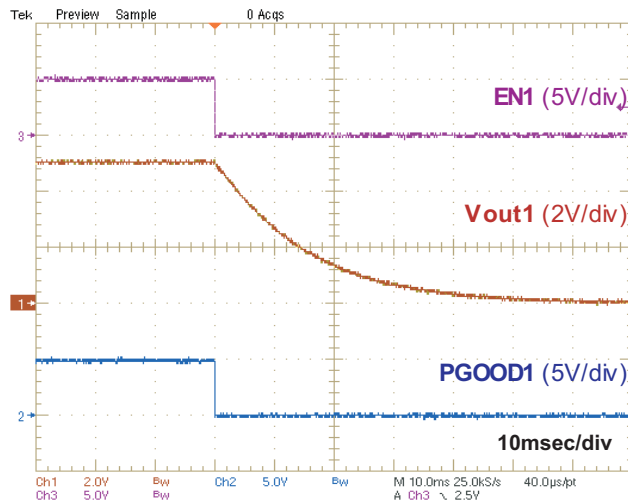


Figure 36.

3.3-V SOFT-STOP WAVEFORMS

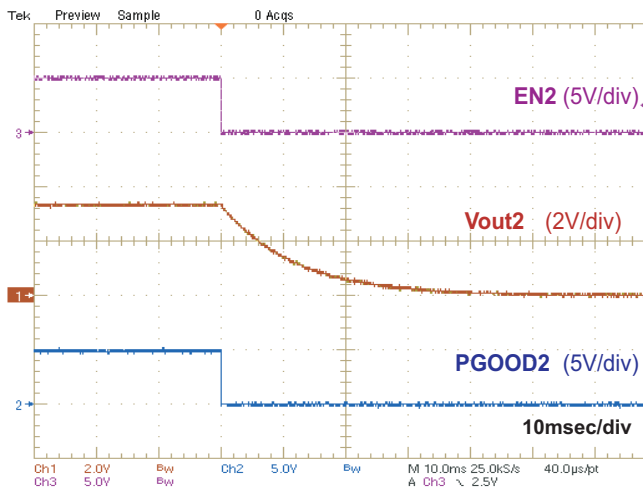


Figure 37.

TYPICAL CHARACTERISTICS (continued)

5.0-V LOAD TRANSIENT RESPONSE

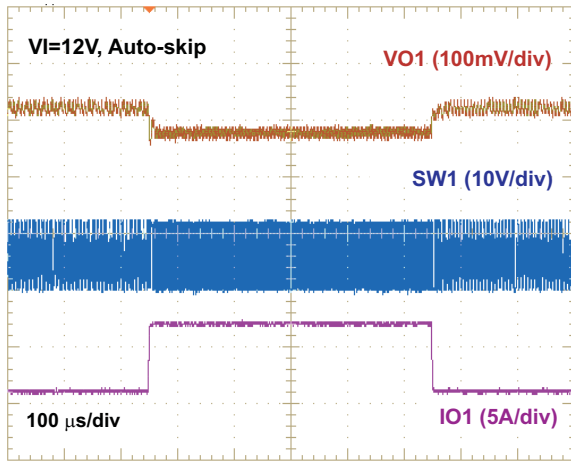


Figure 38.

3.3-V LOAD TRANSIENT RESPONSE

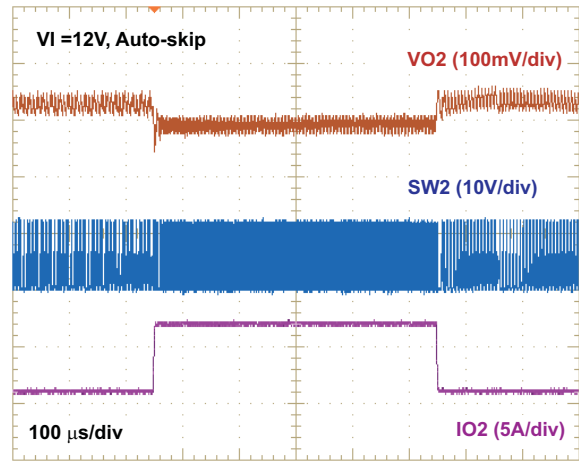


Figure 39.

DETAILED DESCRIPTION

ENABLE AND SOFT START

When EN is *Low*, the TPS51220A is in the shutdown state. Only the 3.3-V LDO stays alive, and consumes 7 μA (typically). When EN becomes *High*, the TPS51220A is in the standby state. The 2-V reference and the 5-V LDO become enabled, and consume about 80 μA with no load condition, and are ready to turn on SMPS channels. Each SMPS channel is turned on when ENx becomes *High*. After ENx is set to high, the TPS51220A begins the softstart sequence, and ramps up the output voltage from zero to the target voltage in 0.96 ms. However, if a slower soft-start is required, an external capacitor can be tied from the ENx pin to GND. In this case, the TPS51220A charges the external capacitor with the integrated 2- μA current source. An approximate external soft-start time would be $t_{\text{EX-SS}} = C_{\text{EX}} / I_{\text{EN12}}$, which means the time from ENx = 1 V to ENx = 2 V. The recommend capacitance is more than 2.2 nF.

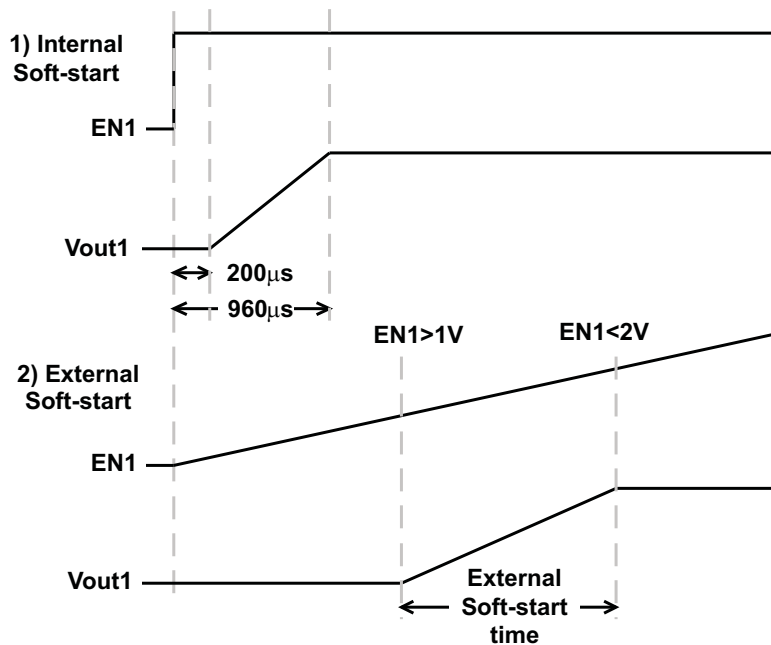


Figure 40. Enable and Soft-start Timing

Table 1. Enable Logic States

EN	EN1	EN2	VREG3	VREF2	VREG5	CH1	CH2
GND	Don't Care	Don't Care	ON	Off	Off	Off	Off
Hi	Lo	Lo	ON	ON	ON	Off	Off
Hi	Hi	Lo	ON	ON	ON	ON	Off
Hi	Lo	Hi	ON	ON	ON	Off	ON
Hi	Hi	Hi	ON	ON	ON	ON	ON

PRE-BIASED START-UP

The TPS51220A supports a pre-biased start up by preventing negative inductor current during soft-start when the output capacitor holds some charge. The initial DRVH signal waits until the voltage feedback signal becomes greater than the internal reference ramping up by the soft-start function. After that, the start-up occurs in the same way the soft-start condition fully discharges, regardless of the SKIPSELx selection.

TPS51220A

SLUS897D DECEMBER 2008 REVISED FEBRUARY 2010

www.ti.com

[查询TPS51220A 供应商](#)

3.3-V, 10-mA LDO (VREG3)

A 3.3-V, 10-mA, linear regulator is integrated in the TPS51220A. This LDO services some of the analog circuit in the device and provides a handy standby supply for 3.3-V *Always On* voltage in the notebook system. Apply a 2.2- μ F (at least 1- μ F), high quality X5R or X7R ceramic capacitor from VREG3 to (signal) GND in adjacent to the device.

2-V, 100- μ A Sink/Source Reference (VREF2)

This voltage is used for the reference of the loop compensation network. Apply a 0.22- μ F (at least 0.1- μ F), high-quality X5R or X7R ceramic capacitor from VREF2 to (signal) GND in adjacent to the device.

5.0-V, 100-mA LDO (VREG5)

A 5.0-V, 100-mA, linear regulator is integrated in the TPS51220A. This LDO services the main analog supply rail and provides the current for gate drivers until switch-over function becomes enable. Apply a 10- μ F (at least 4.7- μ F), high-quality X5R or X7R ceramic capacitor from VREG5 to (power) GND in adjacent to the device.

VREG5 SWITCHOVER

When EN1 is high, PGOOD1 indicates *GOOD* and a voltage of more than 4.8 V is applied to V5SW, the internal 5V-LDO is shut off and the VREG5 is shorted to V5SW by an internal MOSFET after an 7.7-ms delay. When the V5SW voltage becomes lower than 4.65 V, EN1 becomes low, or PGOOD1 indicates *BAD*, the internal switch is turned off, and the internal 5V-LDO resumes immediately.

BASIC PWM OPERATIONS

The main control loop of the SMPS is designed as a fixed frequency, pulse width modulation (PWM) controller. It supports two control schemes; a peak current mode and a proprietary D-CAP mode. Current mode achieves stable operation with any type of output capacitors, including low ESR capacitor(s) such as ceramic or specialty polymer capacitors. D-CAP mode does not require an external compensation circuit, and is suitable for relatively larger ESR capacitor(s) configuration. These control schemes are selected with FUNC pin. See [Table 4](#).

CURRENT MODE

The current mode scheme uses the output voltage information and the inductor current information to regulate the output voltage. The output voltage information is sensed by VFBx pin. The signal is compared with the internal 1-V reference and the voltage difference is amplified by a transconductance amplifier (VFB-AMP). The inductor current information is sensed by CSPx and CSNx pins. The voltage difference is amplified by another transconductance amplifier (CS-AMP). The output of the VFB-AMP indicates the target peak inductor current. If the output voltage decreases, the TPS51220A increases the target inductor current to raise the output voltage. Alternatively, if the output voltage rises, the TPS51220A decreases the target inductor current to reduce the output voltage.

At the beginning of each clock cycle, the high-side MOSFET is turned on, or becomes 'ON' state. The high-side MOSFET is turned off, or becomes *OFF* state, after the inductor current becomes the target value which is determined by the combination value of the output of the VFB-AMP and a ramp compensation signal. The ramp compensation signal is used to prevent sub-harmonic oscillation of the inductor current control loop. The high-side MOSFET is turned on again at the next clock cycle. By repeating the operation in this manner, the controller regulates the output voltage. The synchronous low-side or the *rectifying* MOSFET is turned on each *OFF* state to keep the conduction loss minimum.

D-CAP™ MODE

With the D-CAP mode operation, the PWM comparator compares VREF2 with the combination value of the COMP voltage, VFB-AMP output, and the ramp compensation signal. When the both signals are equal at the peak of the voltage sense signal, the comparator provides the *OFF* signal to the high-side MOSFET driver. Because the compensation network is implemented on the part and the output waveform itself is used as the error signal, external circuit is simplified. Another advantage is its inherent fast transient response. A trade-off is a sufficient amount of ESR required in the output capacitor. The D-CAP™ mode is suitable for relatively larger output ripple voltage application. The inductor current information is used for the overcurrent protection and light load operation.

PWM FREQUENCY CONTROL

The TPS51220A has a fixed frequency control scheme with 180° phase shift. The switching frequency can be determined by an external resistor which is connected between RF pin and GND, and can be calculated using Equation 1.

$$f_{sw} [\text{kHz}] = \frac{1 \times 10^5}{RF [\text{k}\Omega]} \quad (1)$$

TPS51220A can also synchronize to more than 2.5 V amplitude external clock by applying the signal to the RF pin. The set timing of channel 1 initiates at the raising edge (1.3 V typ) of the clock and channel 2 initiates at the falling edge (1.1 V typ). Therefore, the 50% duty signal makes both channels 180° phase shift.

When the external clock synchronization is selected, the following conditions are required.

- Remove RF resistor
- Add clock signal before EN1 or EN2 turning on

The TPS51220A does NOT support switching frequency change on-the-fly. (neither from the switching frequency set by the RF resistor to the external clock, nor vice versa)

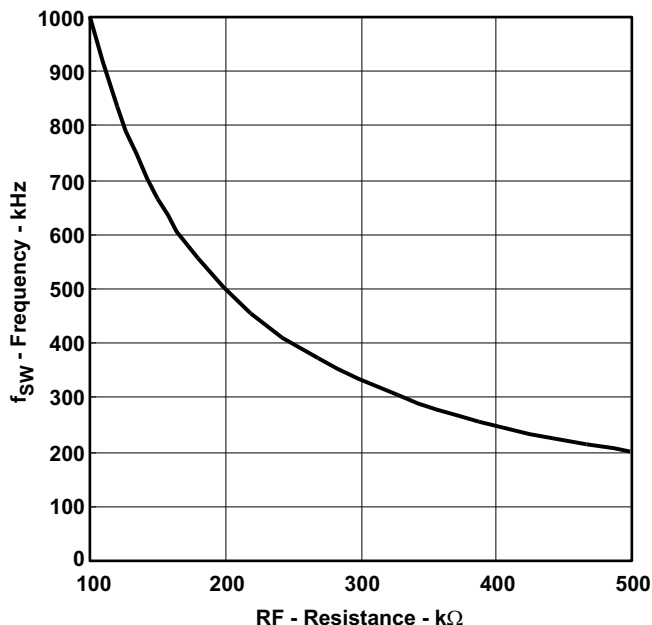


Figure 41. Switching Frequency vs RF

180 Degrees Phase Shift and Blanking Time

The two channels of the SMPS operate 180 degrees phase shift. This scheme helps in reducing the input RMS current. As a result, the device provides the benefits of saving the number and power loss of the input bulk capacitors. To minimize interaction between the two channels caused by switching noise, blanking time is implemented. The loop comparator output is masked during the blanking time to avoid false turning off the channel.

There are two cases where the inter-channel communication can take place:

1. One channel's switching node falling edge is close to another channel's switching node rising edge.
2. One channel's switching node falling edge is close to another channel's switching node falling edge.

In both cases, the TPS51220A shows jitter inherent to the blanking time. Since the device is a fixed frequency controller, the rising edge of the switching node is settled at the clock cycle. Consequently, jitter is observed at a period of switching node falling edge. This jitter does not represent small signal instability. In fact, jittering is a

normal action of control loop against timing deviation caused by any accidental event such as noise, or the blanking time, adjusting back to the regulation point. A small amount of jittering does not harm the voltage regulation. However; if the user wants a further reduction of jitter, using the external clock synchronization provides adjustable phase shift between channels to avoid overlapping of switching events. See the *PWM Frequency Control* section.

LIGHT LOAD OPERATION

The TPS51220A automatically reduces switching frequency at light load conditions to maintain high efficiency if *Auto Skip* or *Out-of-Audio™* mode is selected by SKIPSELx. This reduction of frequency is achieved by skipping pulses. As the output current decreases from heavy load condition, the inductor current is also reduced and eventually comes to the point that its *peak* reaches a predetermined current, $I_{LL(PEAK)}$, which indicates the boundary between heavy-load and light-load conditions. Once the top MOSFET is turned on, the TPS51220A does not allow it to be turned off until it reaches $I_{LL(PEAK)}$. This eventually causes an overvoltage condition to the output and pulse skipping. From the next pulse after zero-crossing is detected, $I_{LL(PEAK)}$ is limited by the ramp-down signal $I_{LL(PEAK)RAMP}$, which starts from 25% of the overcurrent limit setting ($I_{OCL(PEAK)}$): (see the *Current Protection* section) toward 5% of $I_{OCL(PEAK)}$ over one switching cycle to prevent causing large ripple. The transition load point to the light load operation $I_{LL(DC)}$ can be calculated in [Equation 2](#).

$$I_{LL(DC)} = I_{LL(PEAK)} - 0.5 \times I_{IND(RIPPLE)} \quad (2)$$

$$I_{IND(RIPPLE)} = \frac{1}{L \times f_{SW}} \times \frac{(V_{IN} - V_{OUT}) \times V_{OUT}}{V_{IN}}$$

where

- f_{SW} is the PWM switching frequency which is determined by RF resistor setting or external clock (3)

$$I_{LL(PEAK)RAMP} = (0.2 - 0.13 \times t \times f_{SW}) \times I_{OCL(PEAK)} \quad (4)$$

Switching frequency versus output current in the light load condition is a function of L , f , V_{IN} and V_{OUT} , but it decreases almost proportionally to the output current from the $I_{LL(DC)}$, as described in [Equation 2](#); while maintaining the switching synchronization with the clock. Due to the synchronization, the switching waveform in boundary load condition (close to $I_{LL(DC)}$) appears as a sub-harmonic oscillation; however, it is the intended operation.

If SKIPSELx is tied to GND, the TPS51220A works on a constant frequency of f_{SW} regardless its load current.

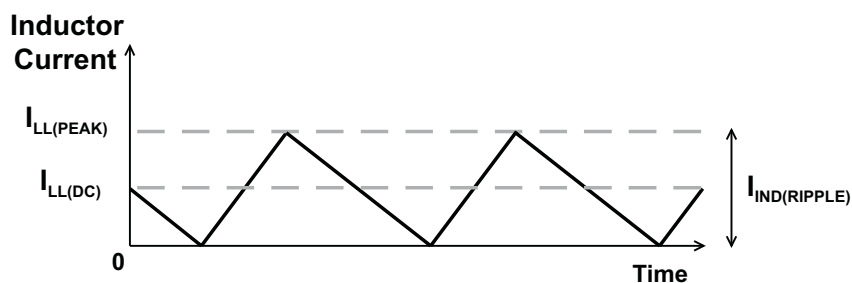


Figure 42. Boundary Between Pulse Skipping and CCM

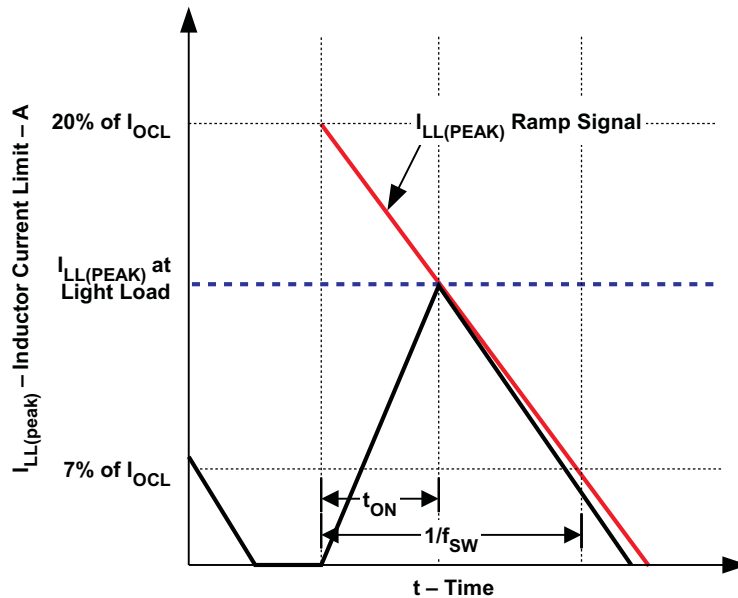


Figure 43. Inductor Current Limit at Pulse Skipping

Table 2. Skip Mode Selection

SKIPSELx	GND	VREF2	VREG3	VREG5
OPERATING MODE	Continuous Conduction	Auto Skip	OOA Skip (maximum 7 skips, for <400 kHz)	OOA Skip (maximum 15 skips, for equal to or greater than 400kHz)

OUT OF AUDIO SKIP OPERATION

Out-Of-Audio™ (OOA) light-load mode is a unique control feature that keeps the switching frequency above acoustic audible frequencies toward virtually no load condition while maintaining state-of-the-art high conversion efficiency. When OOA is selected, the switching frequency is kept higher than audible frequency range in any load condition. The TPS51220A automatically reduced switching frequency at light-load conditions. The OOA control circuit monitors the states of both MOSFETs and forces an ON state if the predetermined number of pulses are skipped. The high-side MOSFET is turned on before the output voltage declines down to the target value, so that eventually an overvoltage condition is caused. The OOA control circuit detects this overvoltage condition and begins modulating the skip-mode on time to keep the output voltage.

The TPS51220A supports a wide-switching frequency range, therefore, the OOA skip mode has two selections. See Table 2. When the 300-kHz switching frequency is selected, a maximum of seven (7) skips (SKIPSEL=3.3 V) makes the lowest frequency at 37.5 kHz. If a 15-skip maximum is chosen, it becomes 18.8 kHz, hence the maximum 7 skip is suitable for less than 400 kHz, and the maximum 15 skip is 400 kHz or greater.

99% DUTY CYCLE OPERATION

In a low-dropout condition such as 5-V input to 5-V output, the basic control loop attempts to maintain 100% of the high-side MOSFET ON. However, with the N-channel MOSFET used for the top switch, it is not possible to use the 100% on-cycle to charge the boot strap capacitor. When high duty is required, the TPS51220A extends the ON period (by skipping a maximum of three clock cycles and reducing the switching frequency to 25% of the steady state value) and asserts the OFF state after extended ON.

TPS51220A

SLUS897D DECEMBER 2008 REVISED FEBRUARY 2010

www.ti.com

[查询TPS51220A 供应链](#)

HIGH-SIDE DRIVER

The high-side driver is designed to drive high current, low $R_{DS(on)}$ N-channel MOSFET(s). The drive capability is represented by its internal resistance, which is 1.7Ω for VBSTx to DRVHx, and 1Ω for DRVHx to SWx. When configured as a floating driver, 5 V of bias voltage is delivered from VREG5 supply. The instantaneous drive current is supplied by the flying capacitor between VBSTx and SWx pins. The average drive current is equal to the gate charge at $V_{gs} = 5V$ times switching frequency. This gate drive current as well as the low-side gate drive current times 5 V makes the driving power which needs to be dissipated mainly from TPS51220A package. A dead time to prevent shoot through is internally generated between high-side MOSFET off to low-side MOSFET on, and low-side MOSFET off to high-side MOSFET on.

LOW-SIDE DRIVER

The low-side driver is designed to drive high-current low- $R_{DS(on)}$ N-channel MOSFET(s). The drive capability is represented by its internal resistance, which are 1.3Ω for VREG5 to DRVLx and 0.7Ω for DRVLx to GND. The 5-V bias voltage is delivered from VREG5 supply. The instantaneous drive current is supplied by an input capacitor connected between VREG5 and GND. The average drive current is also calculated by the gate charge at $V_{gs} = 5V$ times switching frequency.

CURRENT SENSING SCHEME

In order to provide both good accuracy and cost effective solution, the TPS51220A supports external resistor sensing and inductor DCR sensing. An RC network with high quality X5R or X7R ceramic capacitor should be used to extract voltage drop across DCR. $0.1\mu F$ is a good value to start the design. CSPx and CSNx should be connected to positive and negative terminal of the sensing device respectively. TPS51220A has an internal current amplifier. The gain of the current amplifier, G_c , is selected by TRIP terminal. In any setting, the output signal of the current amplifier becomes 100mV at the OCL setting point. This means that the current sensing amplifier normalize the current information signal based on the OCL setting. Attaching a RC network recommended even with a resistor sensing scheme to get an accurate current sensing; see the external parts selection session for detailed configurations.

ADAPTIVE ZERO CROSSING

TPS51220A has an adaptive zero crossing circuit which performs optimization of the zero inductor current detection at skip mode operation. This function pursues ideal low-side MOSFET turning off timing and compensates inherent offset voltage of the ZC comparator and delay time of the ZC detection circuit. It prevents SW-node swing-up caused by too late detection and minimizes diode conduction period caused by too early detection. As a result, better light load efficiency is delivered.

CURRENT PROTECTION

TPS51220A has cycle-by-cycle overcurrent limiting control. If the inductor current becomes larger than the overcurrent trip level, TPS51220A turns off high-side MOSFET, turns on low-side MOSFET and waits for the next clock cycle.

$I_{OCL(PEAK)}$ sets peak level of the inductor current. Thus, the dc load current at overcurrent threshold, $I_{OCL(DC)}$, can be calculated as follows;

$$I_{OCL(DC)} = I_{OCL(PEAK)} - 0.5 \times I_{IND(RIPPLE)} \quad (5)$$

$$I_{OCL(PEAK)} = \frac{V_{OCL}}{R_{SENSE}}$$

where

- R_{SENSE} is resistance of current sensing device
- $V_{(OCL)}$ is the overcurrent trip threshold voltage which is determined by TRIP pin voltages as shown in [Table 3](#) (6)

In an overcurrent condition, the current to the load exceeds the current to the output capacitor thus the output voltage tends to fall down, and it ultimately crosses the undervoltage protection threshold and shutdown.

Table 3. OCL Trip and Discharge Selection

TRIP	GND	VREF2	VREG3	VREG5
$V_{(OCL)}$ (OCL TRIP VOLTAGE)	$V_{(OCL-ULV)}$ (ULTRA-LOW VOLTAGE)	$V_{(OCL-LV)}$ (LOW VOLTAGE)		
DISCHARGE	Enable	Disable	Disable	Enable

POWERGOOD

The TPS51220A has powergood output for both switcher channels. The powergood function is activated after softstart has finished. If the output voltage becomes within $\pm 5\%$ of the target value, internal comparators detect power good state and the powergood signal becomes high after 1ms internal delay. If the output voltage goes outside of $\pm 10\%$ of the target value, the powergood signal becomes low after 1.5 μ s internal delay. Apply voltage should be less than 6V and the recommended pull-up resistance value is from 100k Ω to 1M Ω .

OUTPUT DISCHARGE CONTROL

The TPS51220A discharges output when ENx is low. The TPS51220A discharges outputs using an internal MOSFET which is connected to CSNx and GND. The current capability of these MOSFETs is limited to discharge the output capacitor slowly. If ENx becomes high during discharge, MOSFETs are turning off, and some output voltage remains. SMPS changes over to soft-start. The PWM initiates after the target voltage overtakes the remaining output voltage. This function can be disabled as shown in [Table 3](#).

TPS51220A

SLUS897D DECEMBER 2008 / REVISED FEBRUARY 2010

www.ti.com
[查询TPS51220A 供应链](#)

OVERVOLTAGE/UNDERVOLTAGE PROTECTION

TPS51220A monitors the output voltage to detect overvoltage and undervoltage. When the output voltage becomes 15% higher than the target value, the OVP comparator output goes high and the circuit latches as the high-side MOSFET driver OFF and the low-side MOSFET driver ON, and shuts off another channel.

When the feedback voltage becomes lower than 70% of the target voltage, the UVP comparator output goes high and an internal UVP delay counter begins counting. After 1 ms, TPS51220A latches OFF both high-side and low-side MOSFETs, and shuts off another channel. This UVP function is enabled after soft-start has completed. OVP function can be disabled as shown in [Table 4](#). The procedures for restarting from these protection states are:

1. toggle EN
2. toggle EN1 and EN2 or
3. once hit UVLO

Table 4. FUNC Logic States

FUNC	GND	VREF2	VREG3	VREG5
OVP	Enable	Disable	Enable	Disable
CONTROL SCHEME	Current mode	D-CAP mode	D-CAP mode	Current mode

UVLO PROTECTION

The TPS51220A has undervoltage lockout protections (UVLO) for VREG5, VREG3 and VREF2. When the voltage is lower than UVLO threshold voltage, TPS51220A shuts off each output as shown in [Table 5](#). This is non-latch protection.

Table 5. UVLO Protection

	CH1/ CH2	VREG5	VREG3	VREF2
VREG5 UVLO	Off	—	On	On
VREG3 UVLO	Off	Off	—	Off
VREF2 UVLO	Off	Off	On	—

THERMAL SHUTDOWN

The TPS51220A monitors the device temperature. If the temperature exceeds the threshold value, TPS51220A shuts off both SMPS and 5V-LDO, and decreases the VREG3 current limitation to 5 mA (typically). This is non-latch protection.

APPLICATION INFORMATION

EXTERNAL PARTS SELECTION

A buck converter using the TPS51220A consists of linear circuits and a switching modulator. Figure 44 and Figure 45 show basic scheme.

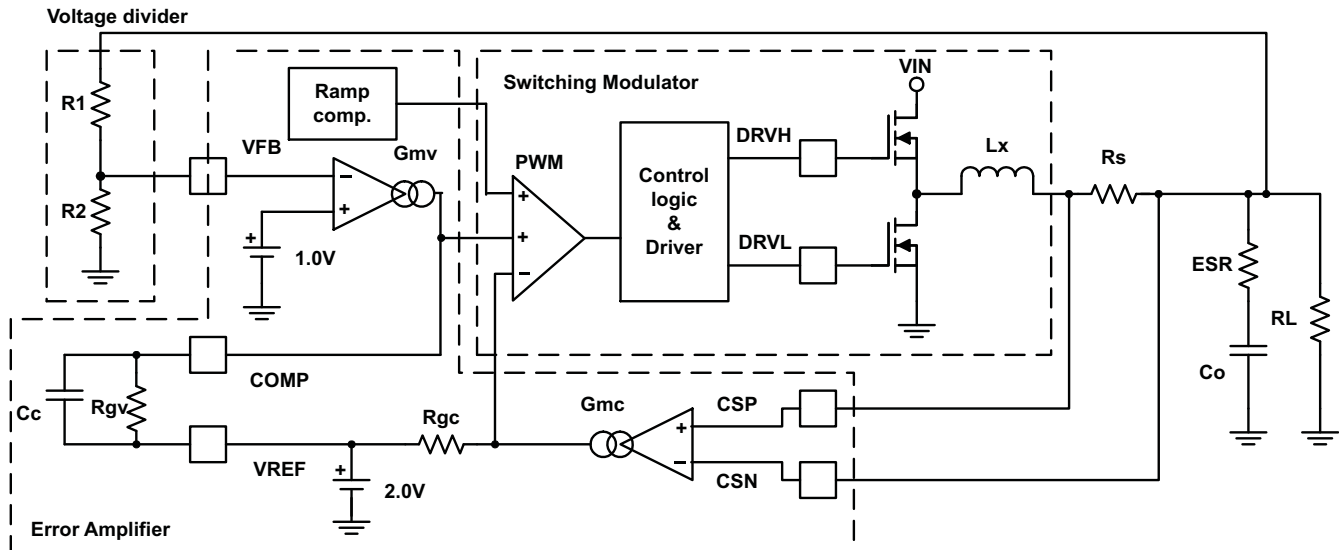


Figure 44. Simplified Current Mode Functional Blocks

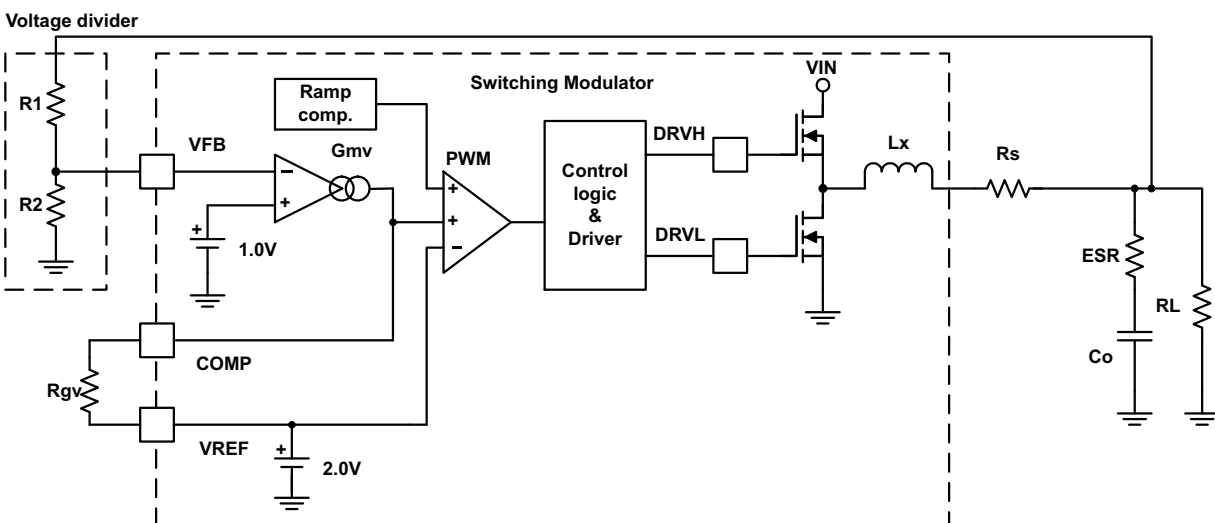


Figure 45. Simplified D-CAP Mode Functional Blocks

The external components can be selected by following manner.

1. **Determine output voltage dividing resistors.** (R1 and R2: shown in Figure 44) using Equation 7 .

$$R1 = (V_{OUT} - 1.0) \times R2 \quad (7)$$

For D-CAP mode, recommended R2 value is from 10kΩ to 20kΩ.

2. **Determine switching frequency.** Higher frequency allows smaller output capacitances, however, degrade efficiency due to increase of switching loss. Frequency setting resistor for RF-pin can be calculated by;

$$R_F[k\Omega] = \frac{1 \times 10^5}{f_{sw} [kHz]} \quad (8)$$

3. **Choose the inductor.** The inductance value should be determined to give the ripple current of approximately 25% to 50% of maximum output current. Recommended ripple current rate is about 30% to 40% at the typical input voltage condition, next equation uses 33%.

$$L = \frac{1}{0.33 \times I_{OUT(MAX)} \times f_{sw}} \times \frac{(V_{IN(TYP)} - V_{OUT}) \times V_{OUT}}{V_{IN(TYP)}} \quad (9)$$

The inductor also needs to have low DCR to achieve good efficiency, as well as enough room above peak inductor current before saturation.

4. Determine the OCL trip voltage threshold, $V_{(OCL)}$, and select the sensing resistor.

The OCL trip voltage threshold is determined by TRIP pin setting. To use a larger value improves the S/N ratio. Determine the sensing resistor using next equation. $I_{OCL(PEAK)}$ should be approximately $1.5 \times I_{OUT(MAX)}$ to $1.7 \times I_{OUT(MAX)}$.

$$R_{SENSE} = \frac{V_{OCL}}{I_{OCL(PEAK)}} \quad (10)$$

5. **Determine Rgv.** Rgv should be determined from preferable droop compensation value and is given by next equation based on the typical number of $G_{mv} = 500\mu S$.

$$R_{gv} = 0.1 \times \frac{I_{OUT(MAX)}}{I_{OCL(PEAK)}} \times V_{OUT} \times \frac{1}{G_{mv} \times V_{droop}} \quad (11)$$

$$R_{gv}[k\Omega] = 200 \times \frac{I_{OUT(MAX)}}{I_{OCL(PEAK)}} \times \frac{V_{OUT}[V]}{V_{droop}[mV]} \quad (12)$$

If no-droop is preferred, attach a series RC network circuit instead of single resistor. Series resistance is determined using [Equation 12](#). Series capacitance can be arbitrarily chosen to meet the RC time constant, but should be kept under 1/10 of f_0 . For D-CAP mode, Rgv is used for adjusting ramp compensation. 10k Ω is a good value to start design with. 6k Ω to 20k Ω can be chosen.

6. Determine output capacitance C_o to achieve a stable operation using the next equation. The 0 dB frequency, f_0 , should be kept under 1/3 of the switching frequency.

$$f_0 = \frac{5}{\pi} \times I_{OCL(PEAK)} \times \frac{1}{V_{OUT}} \times \frac{G_{mv} \times R_{gv}}{C_o} < \frac{f_{sw}}{3} \quad (13)$$

$$C_o > \frac{15}{\pi} \times I_{OCL(PEAK)} \times \frac{1}{V_{OUT}} \times \frac{G_{mv} \times R_{gv}}{f_{sw}} \quad (14)$$

For D-CAP mode, f_0 is determined by the output capacitor's characteristics as below.

$$f_0 = \frac{1}{2\pi \times ESR \times C_o} < \frac{f_{sw}}{3} \quad (15)$$

$$C_o > \frac{3}{2\pi \times ESR \times f_{sw}} \quad (16)$$

For better jitter performance, a sufficient amount of feedback signal is required at VFBx pin. The recommended signal level is approximately 30mV per t_{sw} (switching period) of the ramping up rate, and more than 4 mV of peak-to-peak voltage.

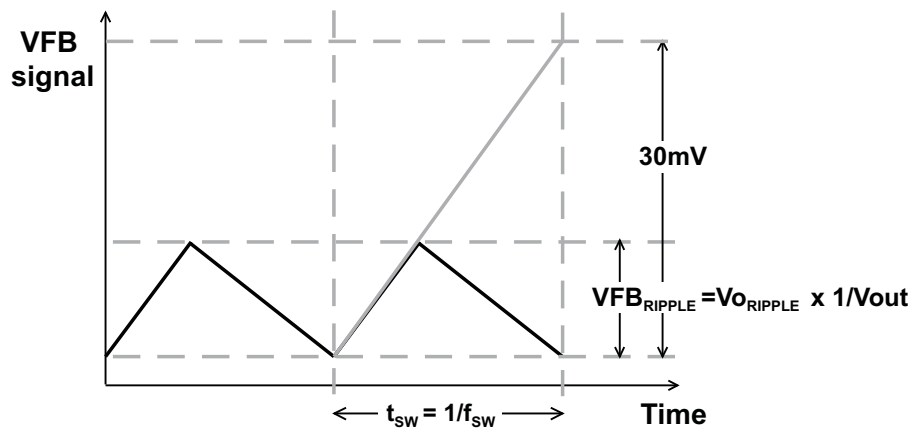


Figure 46. Required voltage feedback ramp signal

7. **Calculate C_c.** The purpose of this capacitance is to cancel zero caused by *ESR* of the output capacitor. If ceramic capacitor(s) is used, there is no need for C_c. If a combination of different capacitors is used, attach a RC network circuit instead of single capacitance to cancel zeros and poles caused by the output capacitors. With single capacitance, C_c is given in Equation 17.

$$C_c = C_o \times \frac{ESR}{R_{gv}} \quad (17)$$

For D-CAP mode, basically C_c is not needed.

8. **Choose MOSFETs** Generally, the on resistance affects efficiency at high load conditions as conduction loss. For a low output voltage application, the duty ratio is not high enough so that the on resistance of high-side MOSFET does not affect efficiency; however, switching speed (t_r and t_f) affects efficiency as switching loss. As for low-side MOSFET, the switching loss is usually not a main portion of the total loss.

RESISTOR CURRENT SENSING

For more accurate current sensing with an external resistor, the following technique is recommended. Adding an RC filter to cancel the parasitic inductance of resistor, this filter value is calculated using Equation 18.

$$C_x \times R_x = \frac{L_x}{R_s} \quad (18)$$

This equation means time-constant of C_x and R_x should match the one of L_x (ESL) and R_s.

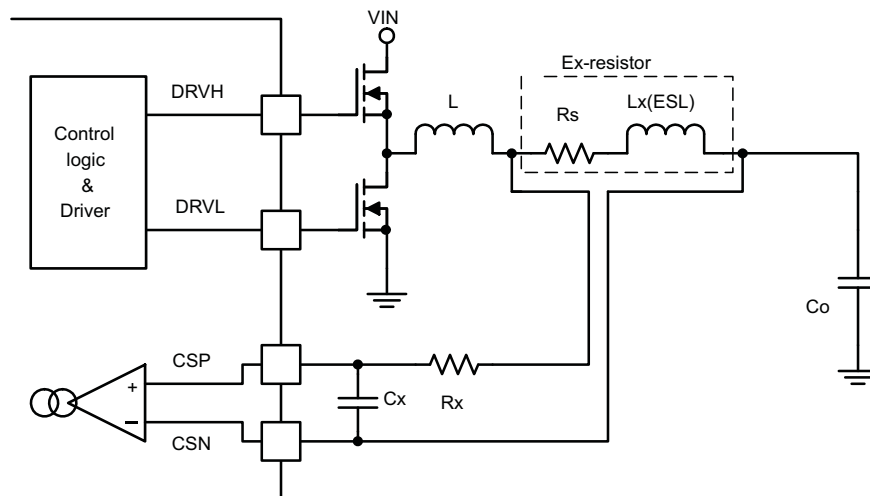


Figure 47. External Resistor Current Sensing

INDUCTOR DCR CURRENT SENSING

To use inductor DCR as current sensing resistor (R_s), the configuration needs to change as below. However, the equation that must be satisfied is the same as the one for the resistor sensing.

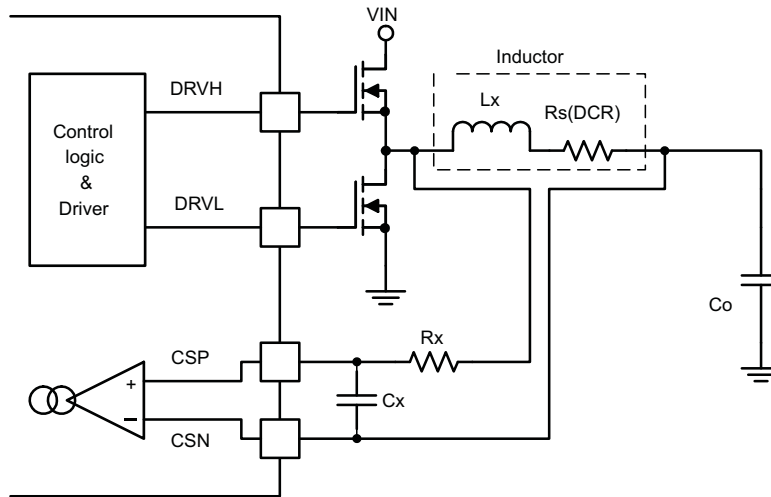


Figure 48. Inductor DCR Current Sensing

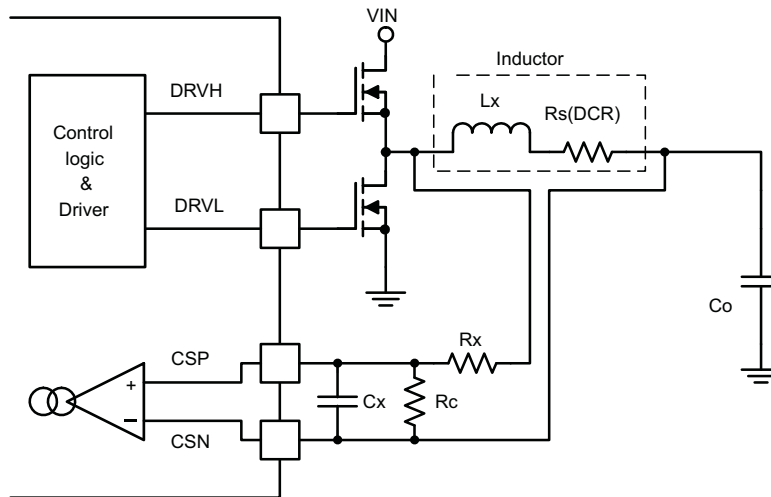


Figure 49. Inductor DCR Current Sensing With Voltage Divider

TPS51220A has fixed $V_{(OCL)}$ point (60 mV or 31 mV). In order to adjust for DCR, a voltage divider can be configured as described in [Figure 49](#).

For R_x , R_c and C_x can be calculated as shown below, and overcurrent limitation value can be calculated as follows:

$$C_x \times (R_x/R_c) = \frac{L_x}{R_s} \quad (19)$$

$$I_{OCL(PEAK)} = V_{OCL} \times \frac{1}{R_s} \times \frac{R_x + R_c}{R_c} \quad (20)$$

[Figure 50](#) shows the compensation technique for the temperature drifts of the inductor DCR value. This scheme assumes the temperature rise at the thermistor (R_{NTC}) is directly proportional to the temperature rise at the inductor.

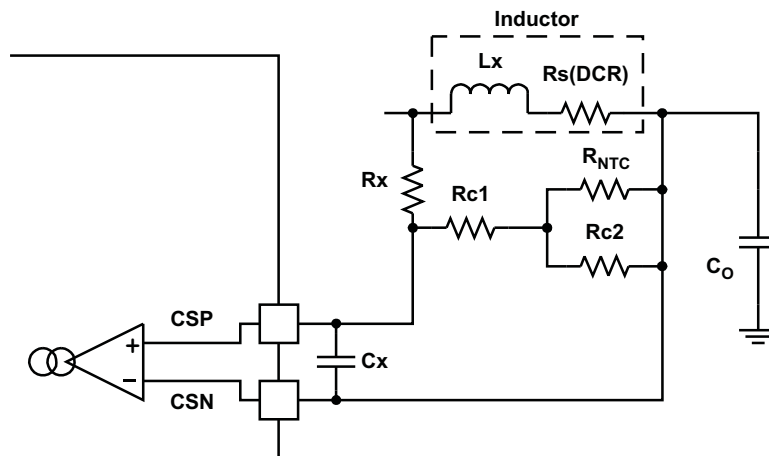


Figure 50. Inductor DCR Current Sensing With Temperature Compensate

LAYOUT CONSIDERATIONS

Certain points must be considered before starting a PCB layout work using the TPS51220A.

Placement

- Place RC network for CSP1 and CSP2 close to the device pins.
- Place bypass capacitors for VREG5, VREG3 and VREF2 close to the device pins.
- Place frequency-setting resistor close to the device pin.
- Place the compensation circuits for COMP1 and COMP2 close to the device pins.
- Place the voltage setting resistors close to the device pins, especially when D-CAP mode is chosen.

Routing (sensitive analog portion)

- Use separate traces for; see Figure 51
 - Output voltage sensing from current sensing (negative-side)
 - Output voltage sensing from V5SW input (when $V_{OUT} = 5V$)
 - Current sensing (positive-side) from switch-node

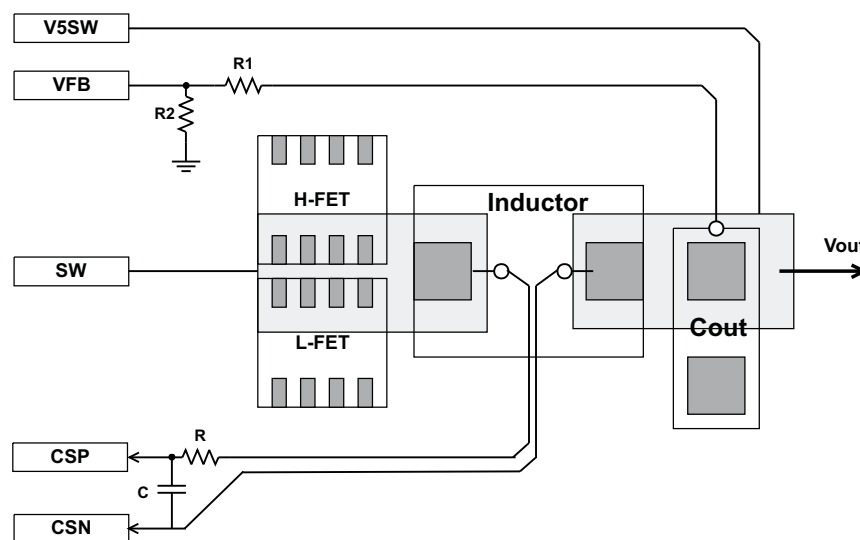


Figure 51. Sensing Trace Routings

- Use Kelvin sensing traces from the solder pads of the current sensing device (inductor or resistor) to current

sensing comparator inputs (CSPx and CSNx). (See [Figure 52](#))

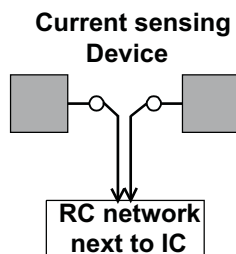


Figure 52. Current Sensing Traces

- Use small copper space for VFBx. These are short and narrow traces to avoid noise coupling
- Connect VFB resistor trace to the positive node of the output capacitor.
- Use signal GND for VREF2 and VREG3 capacitors, RF and VFB resistors, and the other sensitive analog components. Placing a signal GND plane (underneath the IC, and fully covered peripheral components) on the internal layer for shielding purpose is recommended. (See [Figure 53](#))
- Use a thermal land for PowerPAD™. Five or more vias, with 0.33-mm (13-mils) diameter connected from the thermal land to the internal GND plane, should be used to help dissipation. Do NOT connect the GND-pin to this thermal land on the surface layer, underneath the package.

Routing (power portion)

- Use wider/shorter traces of DRV1 for low-side gate drivers to reduce stray inductance.
- Use the parallel traces of SW and DRVH for high-side MOSFET gate drive, and keep them away from DRV1.
- Connect SW trace to source terminal of the high-side MOSFET.
- Use power GND for VREG5, VIN and V_{OUT} capacitors and low-side MOSFETs. Power GND and signal GND should be connected near the device GND terminal. (See [Figure 53](#))

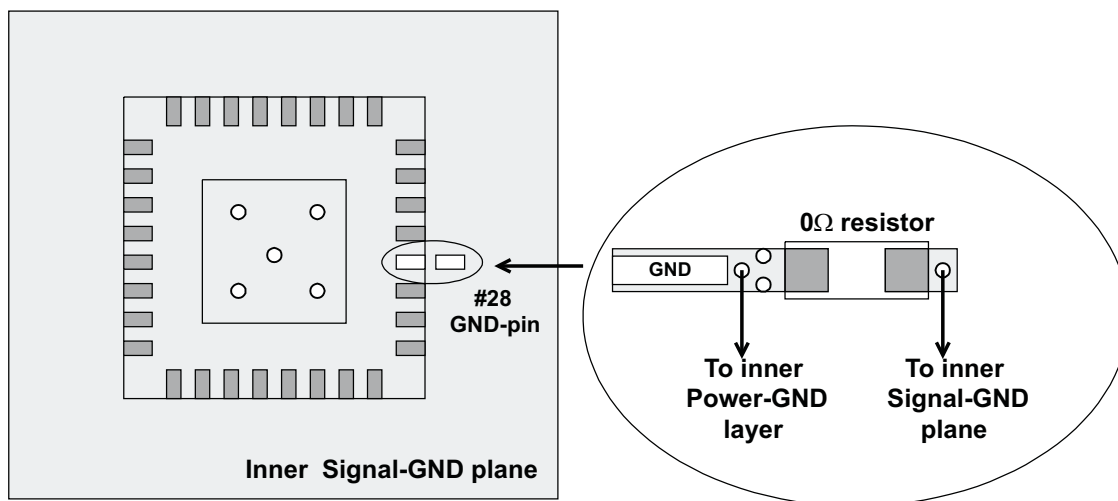


Figure 53. GND Layout Example

APPLICATION CIRCUITS

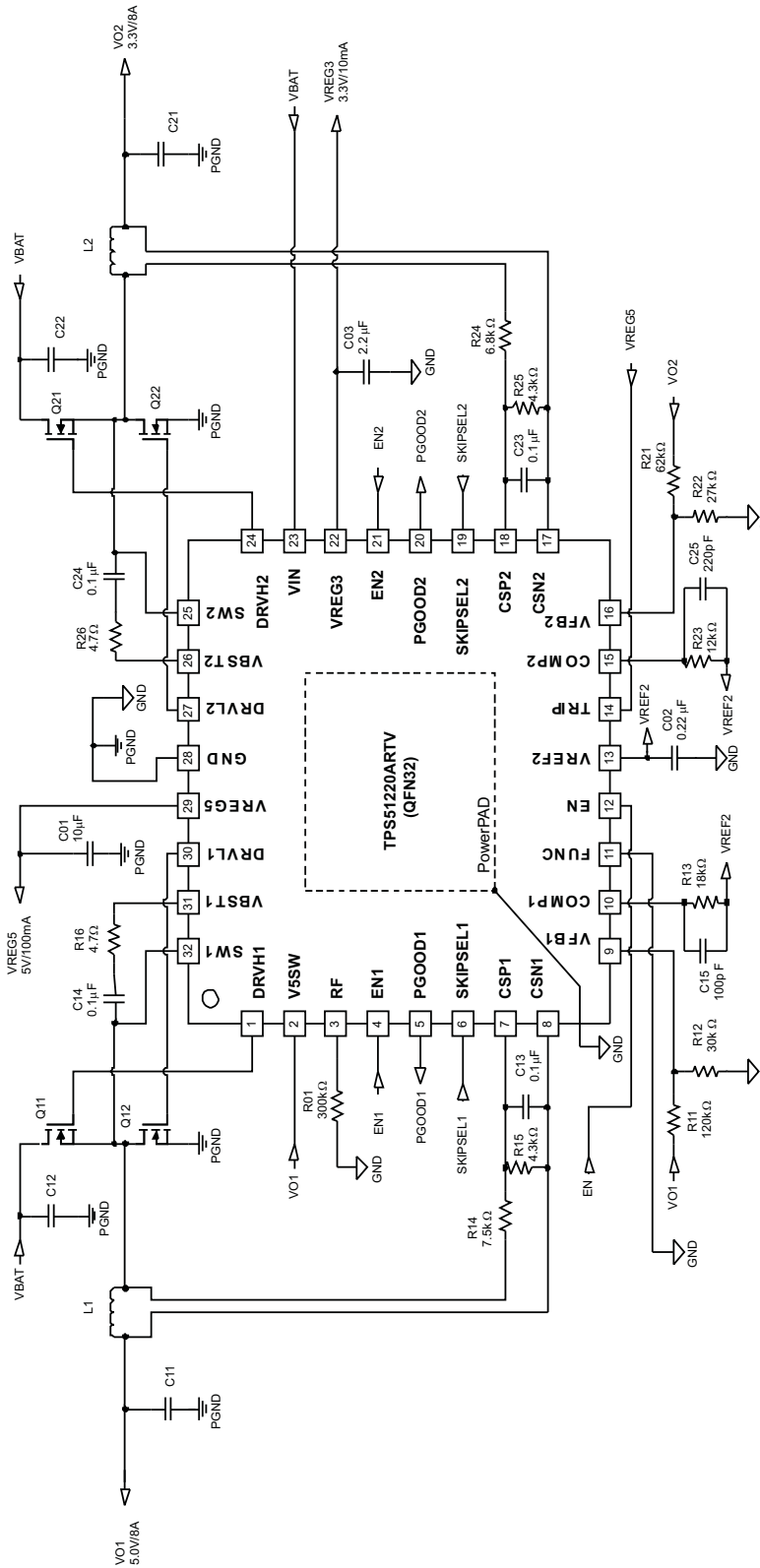


Figure 54. Current Mode, DCR Sensing, 5-V/8-A, 3.3-V/8-A, 330-kHz

TPS51220A

SLUS897D DECEMBER 2008 REVISED FEBRUARY 2010

www.ti.com
[查询TPS51220A 供应商](#)
Table 6. Current Mode, DCR Sensing, 5-V/8-A, 3.3-V/8-A, 330-kHz

SYMBOL	SPECIFICATION	MANUFACTURER	PART NUMBER
C11	2 × 330 μF, 6.3 V, 18 mΩ	Sanyo	6TPE330MIL
C12	2 × 10 μF, 25 V	Murata	GRM32DR71E106K
C21	470 μF, 4.0V, 15 mΩ	Sanyo	4TPE470MFL
C22	2 × 10 μF, 25 V	Murata	GRM32DR71E106K
L1	3.3 μH, 10.7 A, 10.5 mΩ	TOKO	FDV1040-3R3M
L2	3.3 μH, 10.7 A, 10.5 mΩ	TOKO	FDV1040-3R3M
Q11, Q21	30-V, 12 A, 10.5 mΩ	Fairchild	FDMS8692
Q12, Q22	30 V, 18 A, 5.4 mΩ	Fairchild	FDMS8672AS

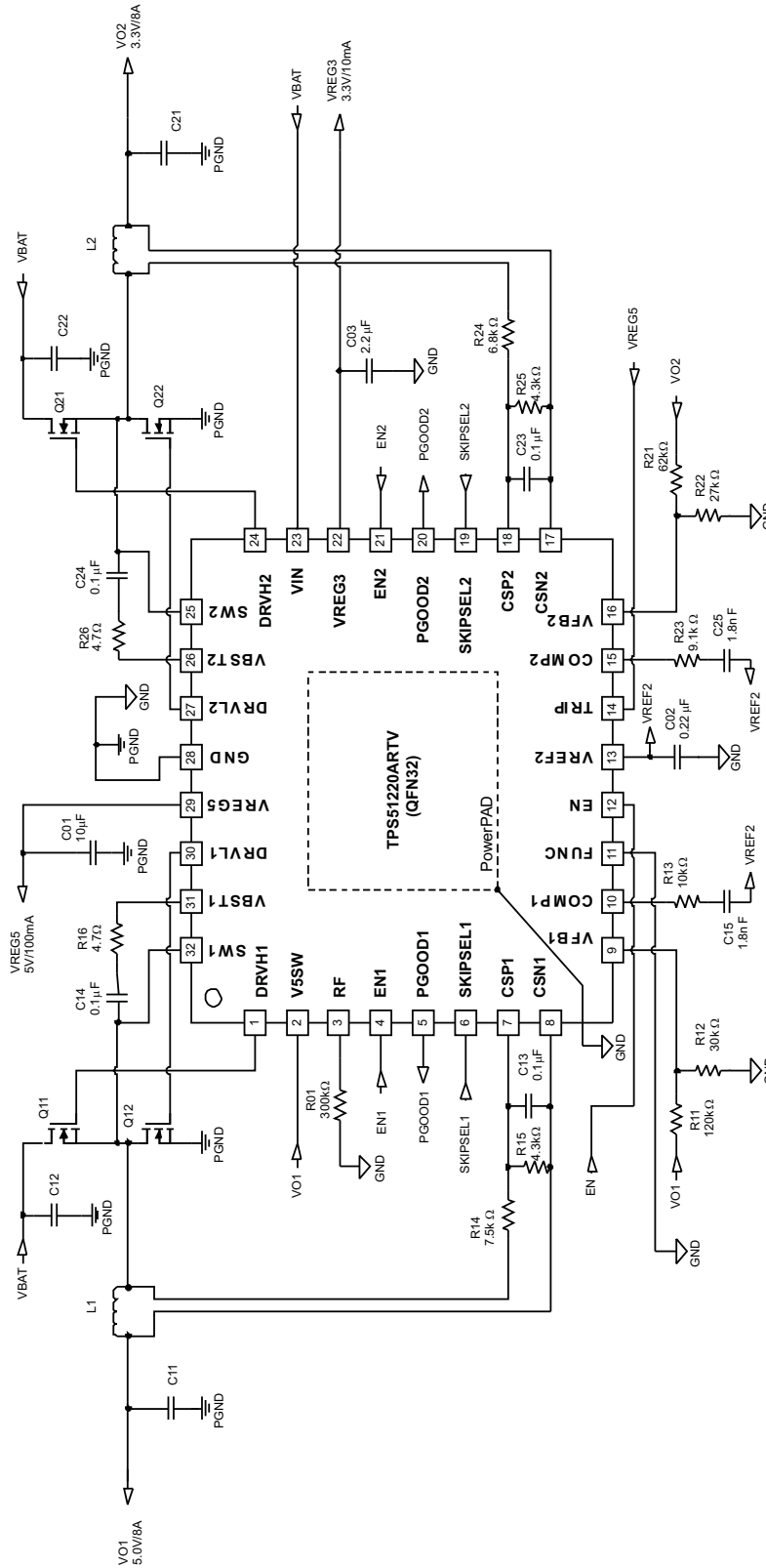


Figure 55. Current Mode (Non-Droop), DCR Sensing, 5-V/8-A, 3.3-V/8-A, 330-kHz

TPS51220A

SLUS897D DECEMBER 2008 REVISED FEBRUARY 2010

www.ti.com
[查询TPS51220A 供应商](#)
Table 7. Current Mode (Non-droop), DCR Sensing, 5-V/8-A, 3.3-V/8-A, 330-kHz

SYMBOL	SPECIFICATION	MANUFACTURER	PART NUMBER
C11	2 x 330 μ F, 6.3 V 18 m Ω	Sanyo	6TPE330MIL
C12	2 x 10 μ F, 25 V	Murata	GRM32DR71E106K
C21	470 μ F, 4.0V, 15 m Ω	Sanyo	4TPE470MFL
C22	2 x 10 μ F, 25 V	Murata	GRM32DR71E106K
L1	3.3 μ H, 10.7 A, 10.5 m Ω	TOKO	FDV1040-3R3M
L2	3.3 μ H, 10.7 A, 10.5 m Ω	TOKO	FDV1040-3R3M
Q11, Q21	30-V, 12-A, 10.5 m Ω	Fairchild	FDMS8692
Q12, Q22	30-V, 18-A, 5.4 m Ω	Fairchild	FDMS8672AS

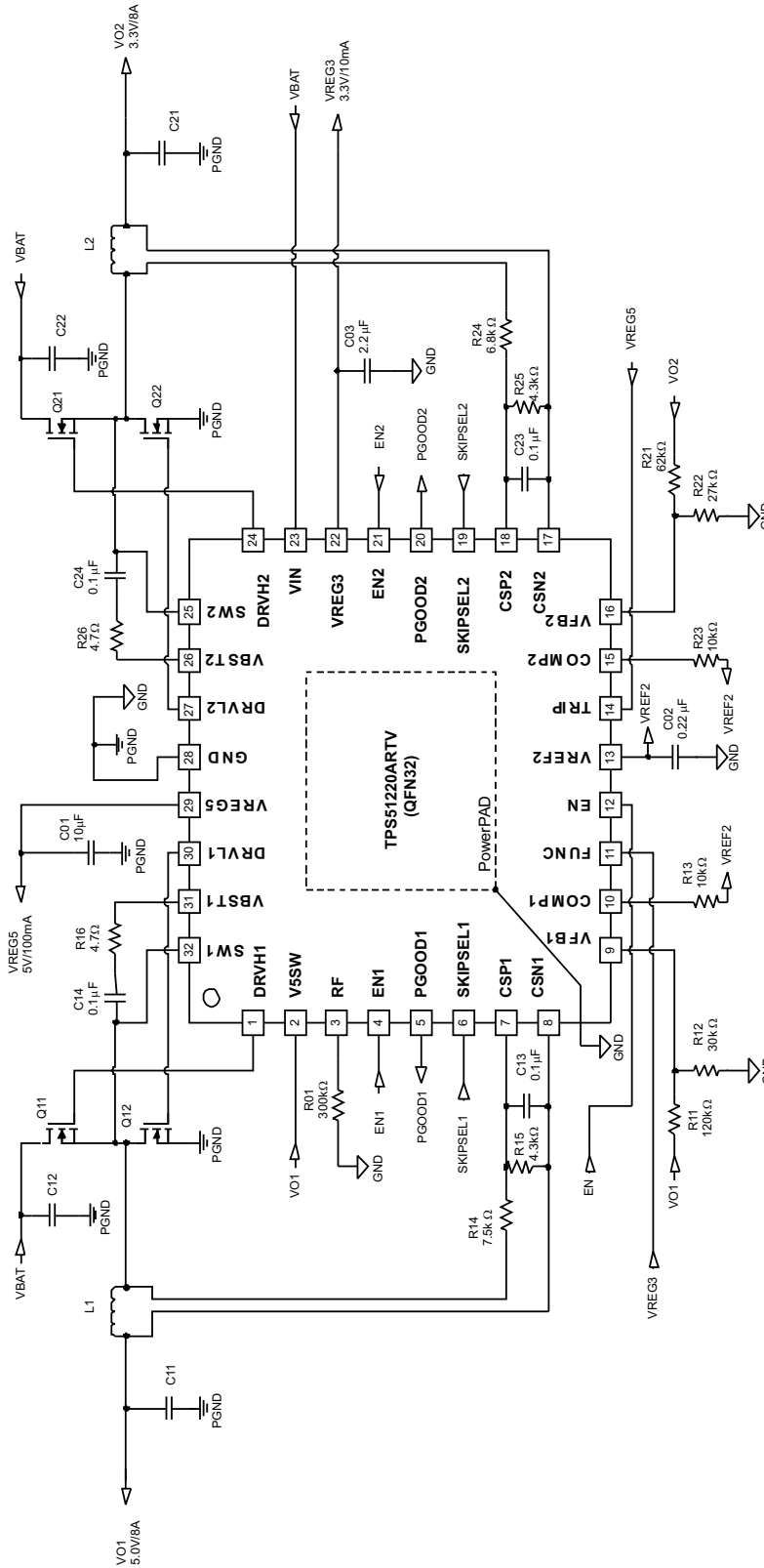


Figure 56. D-CAP Mode, DCR Sensing, 5-V/8-A, 3.3-V/8-A, 330-kHz

TPS51220A

SLUS897D DECEMBER 2008 REVISED FEBRUARY 2010

www.ti.com
[查询TPS51220A 供应商](#)
Table 8. D-CAP Mode, DCR Sensing, 5-V/ 8-A, 3.3-V/8-A, 330-kHz

SYMBOL	SPECIFICATION	MANUFACTURER	PART NUMBER
C11	2 x 330 μ F, 6.3 V, 18 m Ω	Sanyo	6TPE330MIL
C12	2 x 10 μ F, 25 V	Murata	GRM32DR71E106K
C21	470 μ F, 4.0V, 15 m Ω	Sanyo	4TPE470MFL
C22	2 x 10 μ F, 25 V	Murata	GRM32DR71E106K
L1	3.3 μ H, 10.7 A, 10.5 m Ω	TOKO	FDV1040-3R3M
L2	3.3 μ H, 10.7 A, 10.5 m Ω	TOKO	FDV1040-3R3M
Q11, Q21	30 V, 12 A, 10.5 m Ω	Fairchild	FDMS8692
Q12, Q22	30 V, 18 A, 5.4 m Ω	Fairchild	FDMS8672AS

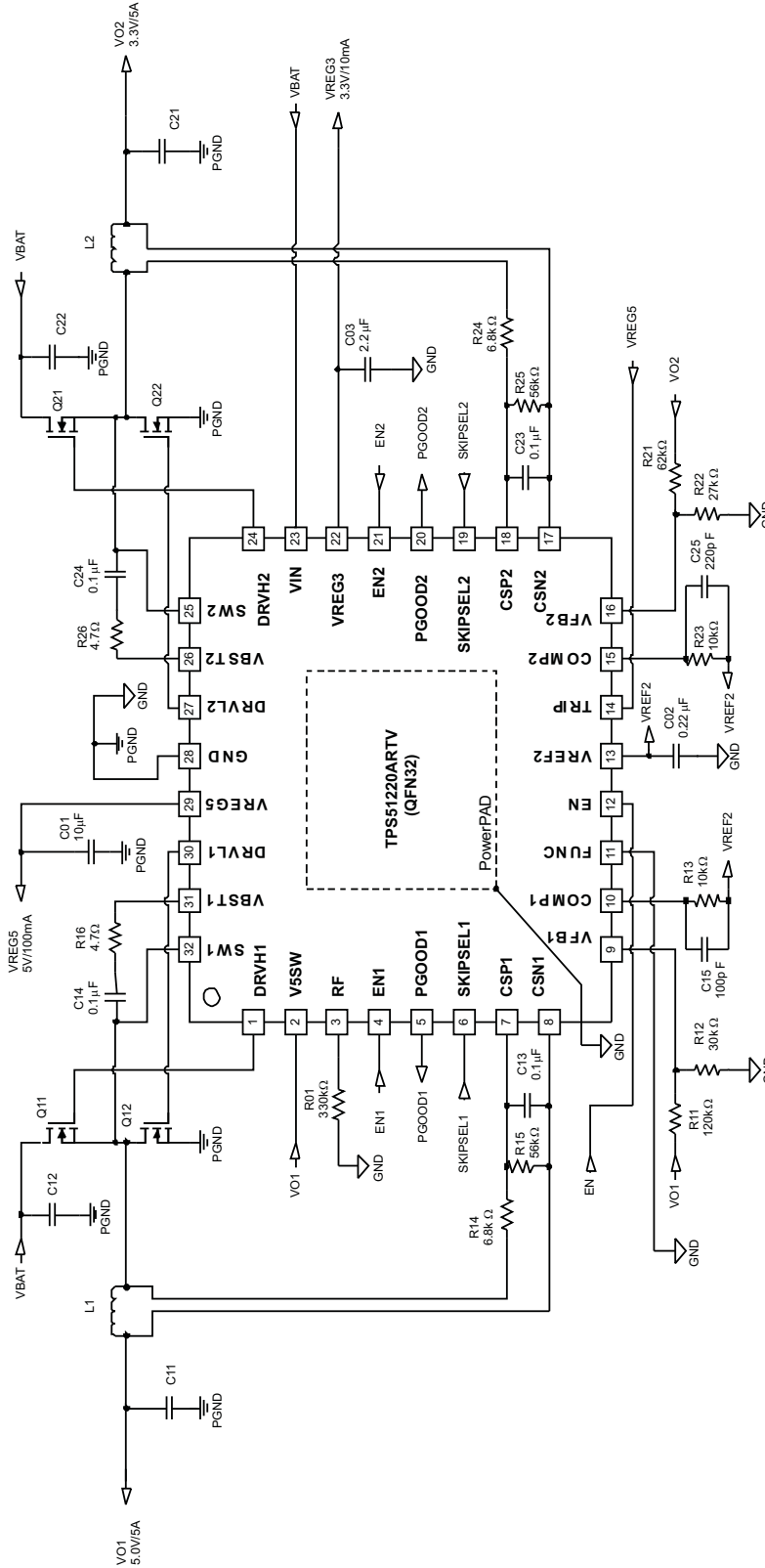


Figure 57. Current Mode, DCR Sensing, 5-V/5-A, 3.3-V/5-A, 300-kHz

TPS51220A

SLUS897D - DECEMBER 2008 - REVISED FEBRUARY 2010

www.ti.com
[查询TPS51220A 供应链](#)
Table 9. Current Mode, DCR Sensing, 5-V/5-A, 3.3-V/5-A, 300-kHz

SYMBOL	SPECIFICATION	MANUFACTURER	PART NUMBER
C11	2 × 120 μF, 6.3V, 15 mΩ	Panasonic	EEFCX0J121R
C12	2 × 10 μF, 25 V	Murata	GRM32DR71E106K
C21	2 × 220 μF, 4.0 V, 15 mΩ	Panasonic	EEFCX0G221R
C22	2 × 10 μF, 25 V	Murata	GRM32DR71E106K
L1	4.0 μH, 10.3 A, 6.6 mΩ	Sumida	CEP125-4R0MC-H
L2	4.0 μH, 10.3 A, 6.6 mΩ	Sumida	CEP125-4R0MC-H
Q11, Q21	30 V, 13.6 A, 9.5 mΩ	IR	IRF7821
Q12, Q22	30 V, 13.8 A, 5.8 mΩ	IR	IRF8113

REVISION HISTORY

Changes from Original (December 2008) to Revision A Page

- Changed $t_{(SSDYL)}$ - SoftStart Delay Typical value From: 140 To: 200 5
- Changed $t_{(SS)}$ - SoftStart Delay Typical value From: 800 To 960 5

Changes from Revision A (March 2009) to Revision B Page

- Changed SW1 and SW2 Abs Max range From: -5 to 34 To: -7 to 34 3
- Changed DRVH1, DRVH2 Abs Max range From: -5 to 39 To: -7 to 39 3
- Added a row to the Recommended Operating Conditions table - DRVH1, DRVH2 (negative overshoot -6 V for $t < 20\%$ duration of the switching period) 3
- Added a row to the Recommended Operating Conditions table - SW1, SW2 (negative overshoot -6 V for $t < 20\%$ duration of the switching period) 3
- Changed the legend of [Figure 22](#) From: $V_I = 12$ V To: Auto-Skip 15
- Changed the legend of [Figure 27](#) From $R_{GV} = 1$ kΩ To: $R_{GV} = 10$ k 16
- Changed the time scale of [Figure 36](#) From: 1 mec/div To: 10msec/div 19
- Changed the time scale of [Figure 37](#) From: 1 mec/div To: 10msec/div 19
- Added subsection: 180 Degrees Phase Shift and Blanking Time 23

Changes from Revision B (October 2009) to Revision C Page

- Added RSN dissipation rating information 3
- Added RSN package ordering information 4
- Added RSN package electrical specifications 6
- Added the RSN package pinout 8

Changes from Revision C (November 2009) to Revision D Page

- Changed the device number in the pin package drawings From: TPS51120A To: TPS51220A 8

PACKAGING INFORMATION

Orderable Device	Status ⁽¹⁾	Package Type	Package Drawing	Pins	Package Qty	Eco Plan ⁽²⁾	Lead/Ball Finish	MSL Peak Temp ⁽³⁾
TPS51220ARSNR	ACTIVE	QFN	RSN	32	3000	Green (RoHS & no Sb/Br)	CU NIPDAU	Level-2-260C-1 YEAR
TPS51220ARSNT	ACTIVE	QFN	RSN	32	250	Green (RoHS & no Sb/Br)	CU NIPDAU	Level-2-260C-1 YEAR
TPS51220ARTVR	ACTIVE	QFN	RTV	32	3000	Green (RoHS & no Sb/Br)	CU NIPDAU	Level-2-260C-1 YEAR
TPS51220ARTVT	ACTIVE	QFN	RTV	32	250	Green (RoHS & no Sb/Br)	CU NIPDAU	Level-2-260C-1 YEAR

⁽¹⁾ The marketing status values are defined as follows:

ACTIVE: Product device recommended for new designs.

LIFEBUY: TI has announced that the device will be discontinued, and a lifetime-buy period is in effect.

NRND: Not recommended for new designs. Device is in production to support existing customers, but TI does not recommend using this part in a new design.

PREVIEW: Device has been announced but is not in production. Samples may or may not be available.

OBSOLETE: TI has discontinued the production of the device.

⁽²⁾ Eco Plan - The planned eco-friendly classification: Pb-Free (RoHS), Pb-Free (RoHS Exempt), or Green (RoHS & no Sb/Br) - please check <http://www.ti.com/productcontent> for the latest availability information and additional product content details.

TBD: The Pb-Free/Green conversion plan has not been defined.

Pb-Free (RoHS): TI's terms "Lead-Free" or "Pb-Free" mean semiconductor products that are compatible with the current RoHS requirements for all 6 substances, including the requirement that lead not exceed 0.1% by weight in homogeneous materials. Where designed to be soldered at high temperatures, TI Pb-Free products are suitable for use in specified lead-free processes.

Pb-Free (RoHS Exempt): This component has a RoHS exemption for either 1) lead-based flip-chip solder bumps used between the die and package, or 2) lead-based die adhesive used between the die and leadframe. The component is otherwise considered Pb-Free (RoHS compatible) as defined above.

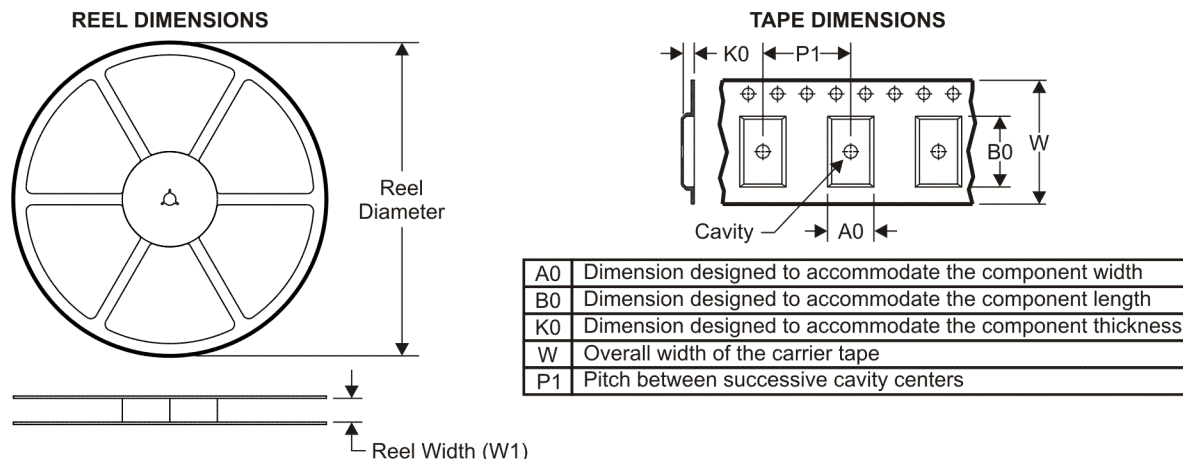
Green (RoHS & no Sb/Br): TI defines "Green" to mean Pb-Free (RoHS compatible), and free of Bromine (Br) and Antimony (Sb) based flame retardants (Br or Sb do not exceed 0.1% by weight in homogeneous material)

⁽³⁾ MSL, Peak Temp. -- The Moisture Sensitivity Level rating according to the JEDEC industry standard classifications, and peak solder temperature.

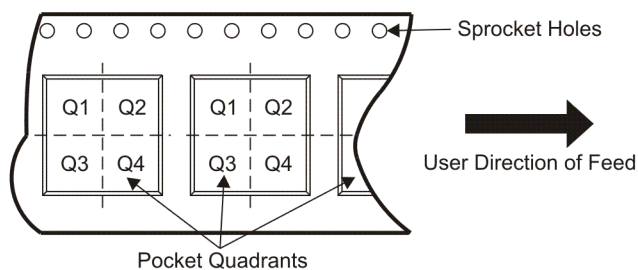
Important Information and Disclaimer:The information provided on this page represents TI's knowledge and belief as of the date that it is provided. TI bases its knowledge and belief on information provided by third parties, and makes no representation or warranty as to the accuracy of such information. Efforts are underway to better integrate information from third parties. TI has taken and continues to take reasonable steps to provide representative and accurate information but may not have conducted destructive testing or chemical analysis on incoming materials and chemicals. TI and TI suppliers consider certain information to be proprietary, and thus CAS numbers and other limited information may not be available for release.

In no event shall TI's liability arising out of such information exceed the total purchase price of the TI part(s) at issue in this document sold by TI to Customer on an annual basis.

TAPE AND REEL INFORMATION



QUADRANT ASSIGNMENTS FOR PIN 1 ORIENTATION IN TAPE



*All dimensions are nominal

Device	Package Type	Package Drawing	Pins	SPQ	Reel Diameter (mm)	Reel Width W1 (mm)	A0 (mm)	B0 (mm)	K0 (mm)	P1 (mm)	W (mm)	Pin1 Quadrant
TPS51220ARSNR	QFN	RSN	32	3000	330.0	12.4	4.25	4.25	1.15	8.0	12.0	Q2
TPS51220ARSNT	QFN	RSN	32	250	180.0	12.4	4.25	4.25	1.15	8.0	12.0	Q2
TPS51220ARTVR	QFN	RTV	32	3000	330.0	12.4	5.3	5.3	1.5	8.0	12.0	Q2
TPS51220ARTVT	QFN	RTV	32	250	180.0	12.4	5.3	5.3	1.5	8.0	12.0	Q2

TAPE AND REEL BOX DIMENSIONS

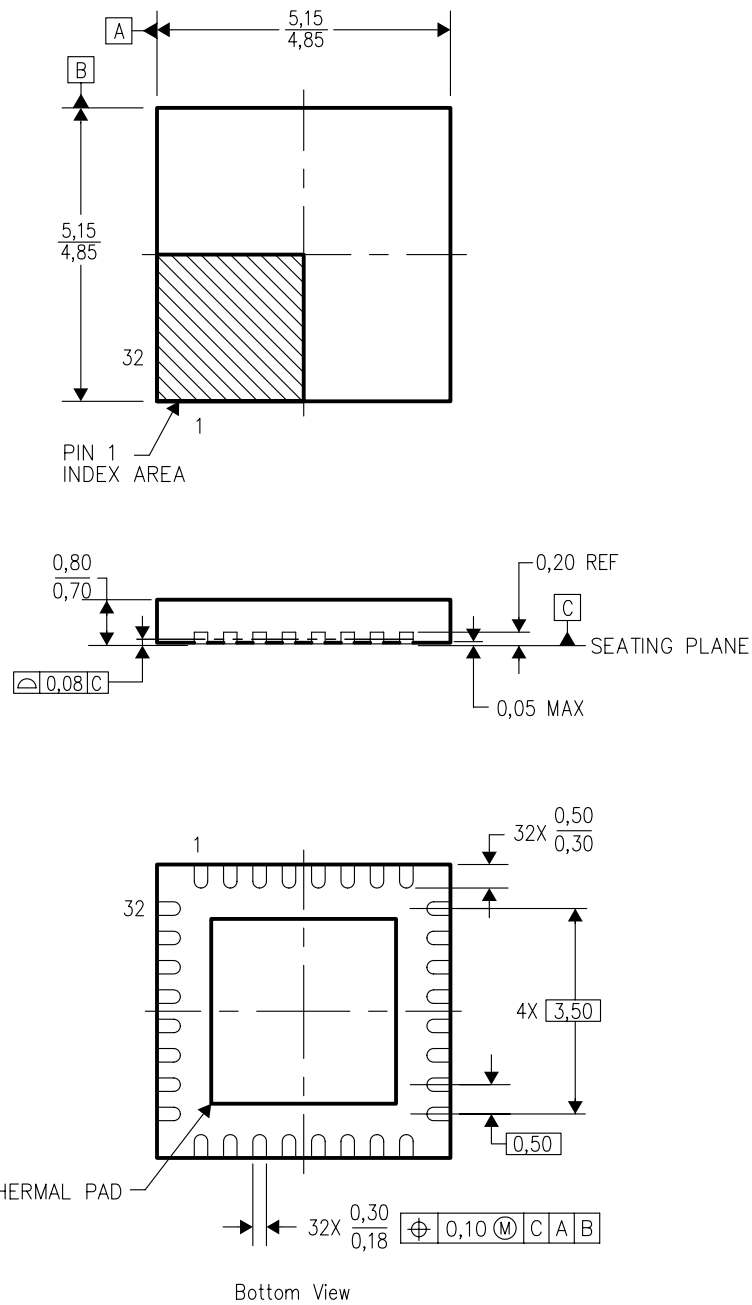


*All dimensions are nominal


Device	Package Type	Package Drawing	Pins	SPQ	Length (mm)	Width (mm)	Height (mm)
TPS51220ARSNR	QFN	RSN	32	3000	346.0	346.0	29.0
TPS51220ARSNT	QFN	RSN	32	250	190.5	212.7	31.8
TPS51220ARTVR	QFN	RTV	32	3000	346.0	346.0	29.0
TPS51220ARTVT	QFN	RTV	32	250	190.5	212.7	31.8

RTV (S-PQFP-N32)

PLASTIC QUAD FLATPACK



4206245/A 07/04

- NOTES:
- A. All linear dimensions are in millimeters. Dimensioning and tolerancing per ASME Y14.5-1994.
 - B. This drawing is subject to change without notice.
 - C. Quad Flatpack, No-Leads (QFN) package configuration.
 -  The package thermal pad must be soldered to the board for thermal and mechanical performance. See the Product Data Sheet for details regarding the exposed thermal pad dimensions.
 - E. Falls within JEDEC MO-220.

RTV (S-PWQFN-N32)

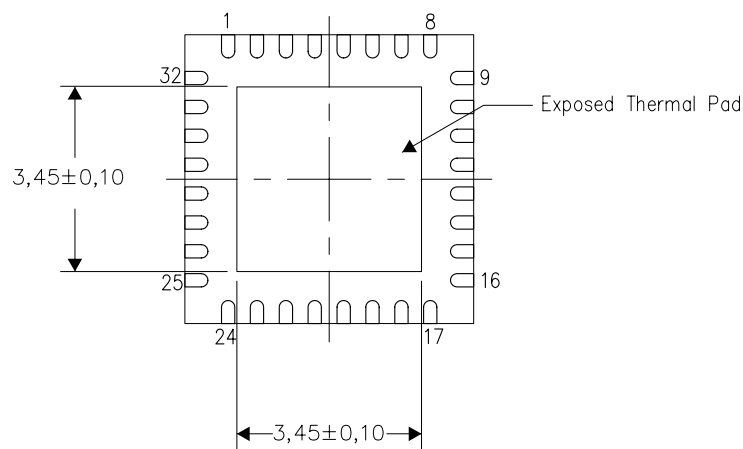
PLASTIC QUAD FLATPACK NO-LEAD

THERMAL INFORMATION

This package incorporates an exposed thermal pad that is designed to be attached directly to an external heatsink. The thermal pad must be soldered directly to the printed circuit board (PCB). After soldering, the PCB can be used as a heatsink. In addition, through the use of thermal vias, the thermal pad can be attached directly to the appropriate copper plane shown in the electrical schematic for the device, or alternatively, can be attached to a special heatsink structure designed into the PCB. This design optimizes the heat transfer from the integrated circuit (IC).

For information on the Quad Flatpack No-Lead (QFN) package and its advantages, refer to Application Report, QFN/SON PCB Attachment, Texas Instruments Literature No. SLUA271. This document is available at www.ti.com.

The exposed thermal pad dimensions for this package are shown in the following illustration.



Bottom View

Exposed Thermal Pad Dimensions

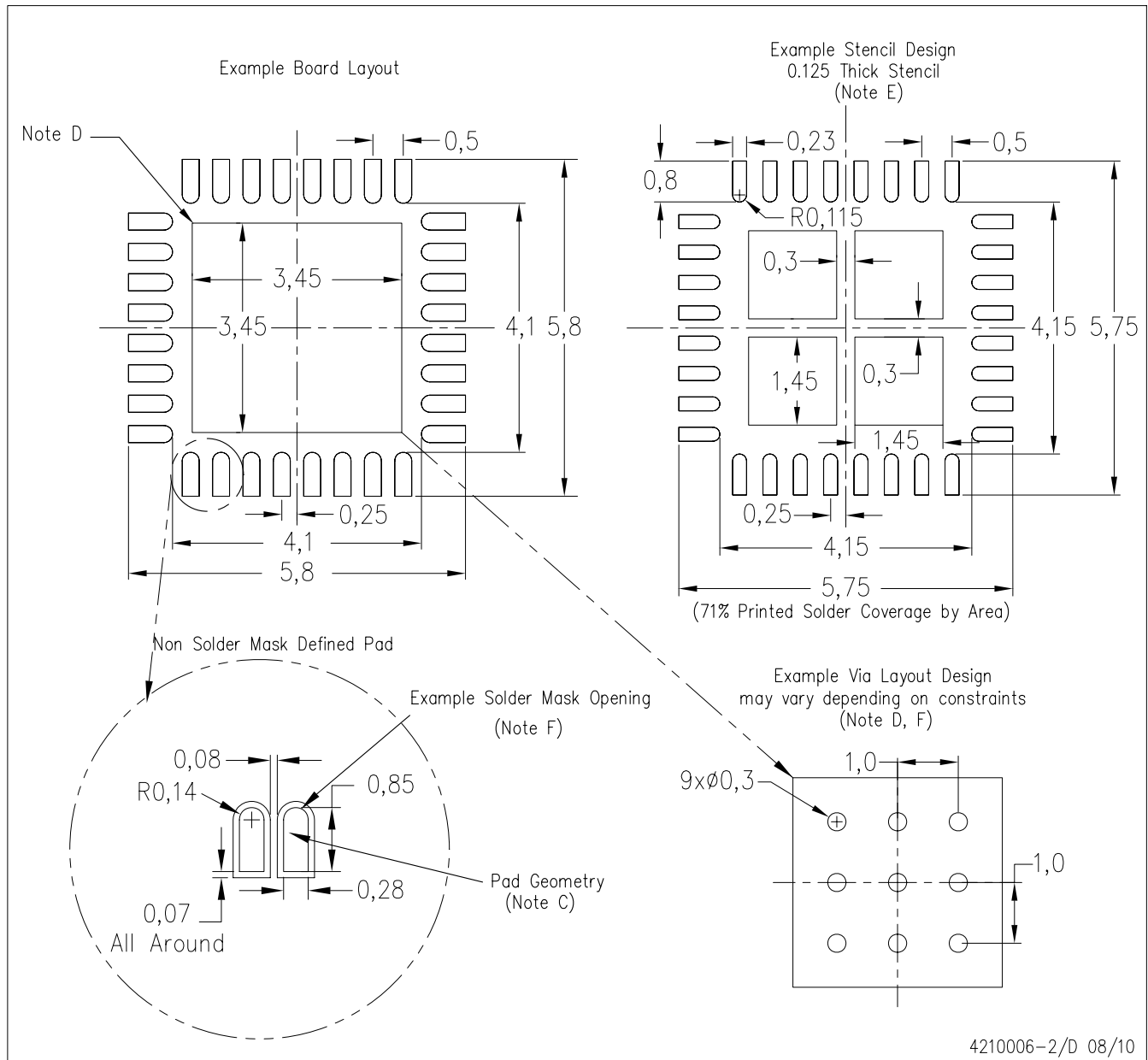
4206250-2/H 11/10

NOTE: A. All linear dimensions are in millimeters

[查询"TPS51220A"供应商](#)

RTV (S-PWQFN-N32)

PLASTIC QUAD FLATPACK NO-LEAD

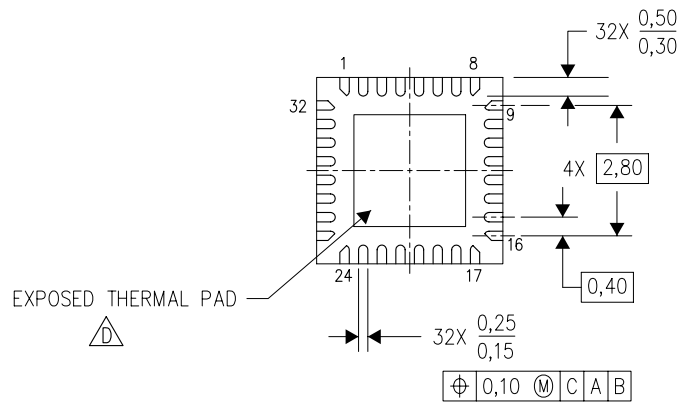
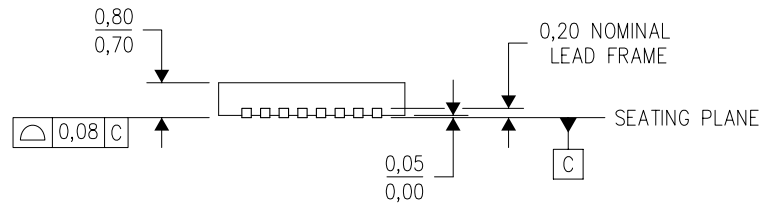
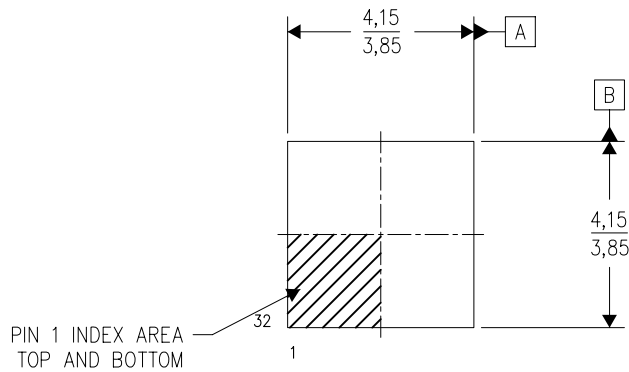


- NOTES:
- All linear dimensions are in millimeters.
 - This drawing is subject to change without notice.
 - Publication IPC-7351 is recommended for alternate designs.
 - This package is designed to be soldered to a thermal pad on the board. Refer to Application Note, Quad Flat-Pack Packages, Texas Instruments Literature No. SCBA017, SLUA271, and also the Product Data Sheets for specific thermal information, via requirements, and recommended board layout. These documents are available at www.ti.com <<http://www.ti.com>>.
 - Laser cutting apertures with trapezoidal walls and also rounding corners will offer better paste release. Customers should contact their board assembly site for stencil design recommendations. Refer to IPC 7525 for stencil design considerations.
 - Customers should contact their board fabrication site for recommended solder mask tolerances and via tenting recommendations for vias placed in the thermal pad.


[查询"TPS51220A"供应商](#)

RSN (S-PWQFN-N32)

PLASTIC QUAD FLATPACK NO-LEAD



4207561/B 03/10

- NOTES:
- A. All linear dimensions are in millimeters. Dimensioning and tolerancing per ASME Y14.5M-1994.
 - B. This drawing is subject to change without notice.
 - C. QFN (Quad Flatpack No-Lead) Package configuration.
 -  D. The package thermal pad must be soldered to the board for thermal and mechanical performance. See the Product Data Sheet for details regarding the exposed thermal pad dimensions.

THERMAL PAD MECHANICAL DATA

[查询"TPS51220A"供应商](#)

RSN (S=PWQFN=N32)

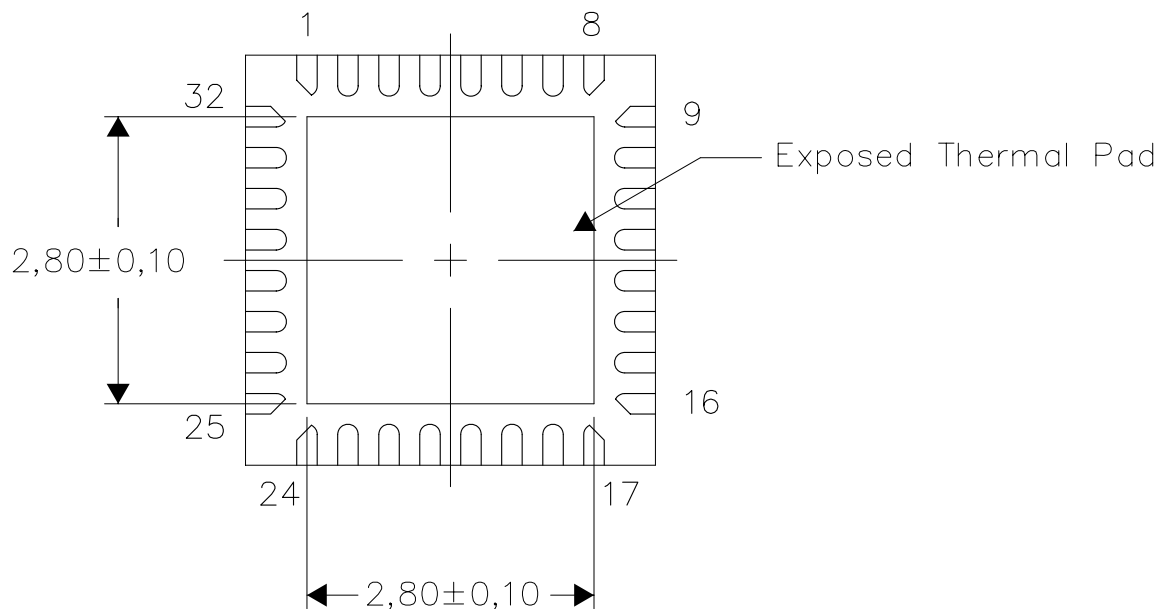
PLASTIC QUAD FLATPACK NO-LEAD

THERMAL INFORMATION

This package incorporates an exposed thermal pad that is designed to be attached directly to an external heatsink. The thermal pad must be soldered directly to the printed circuit board (PCB). After soldering, the PCB can be used as a heatsink. In addition, through the use of thermal vias, the thermal pad can be attached directly to the appropriate copper plane shown in the electrical schematic for the device, or alternatively, can be attached to a special heatsink structure designed into the PCB. This design optimizes the heat transfer from the integrated circuit (IC).

For information on the Quad Flatpack No-Lead (QFN) package and its advantages, refer to Application Report, QFN/SON PCB Attachment, Texas Instruments Literature No. SLUA271. This document is available at www.ti.com.

The exposed thermal pad dimensions for this package are shown in the following illustration.



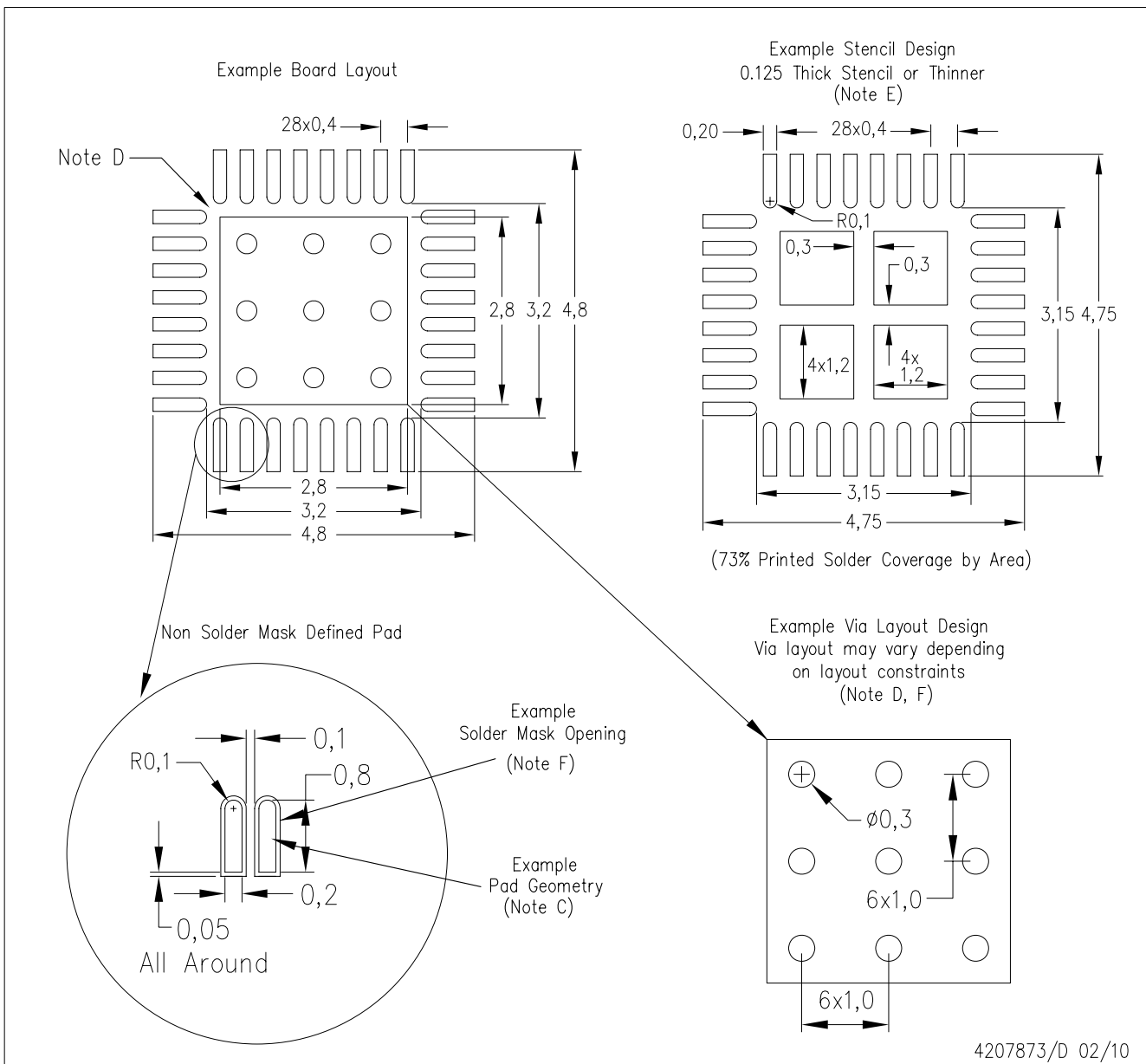
Bottom View

NOTE: All linear dimensions are in millimeters

Exposed Thermal Pad Dimensions

4209775-2/D 07/10

RSN (S-PWQFN-N32)



- NOTES:
- All linear dimensions are in millimeters.
 - This drawing is subject to change without notice.
 - Publication IPC-7351 is recommended for alternate designs.
 - This package is designed to be soldered to a thermal pad on the board. Refer to Application Note, Quad Flat-Pack Packages, Texas Instruments Literature No. SLUA271, and also the Product Data Sheets for specific thermal information, via requirements, and recommended board layout. These documents are available at www.ti.com <<http://www.ti.com>>.
 - Laser cutting apertures with trapezoidal walls and also rounding corners will offer better paste release. Customers should contact their board assembly site for stencil design recommendations. Refer to IPC 7525 for stencil design considerations.
 - Customers should contact their board fabrication site for recommended solder mask tolerances and via tenting recommendations for vias placed in the thermal pad.

[查询"TPS51220A"供应商](#)

IMPORTANT NOTICE

Texas Instruments Incorporated and its subsidiaries (TI) reserve the right to make corrections, modifications, enhancements, improvements, and other changes to its products and services at any time and to discontinue any product or service without notice. Customers should obtain the latest relevant information before placing orders and should verify that such information is current and complete. All products are sold subject to TI's terms and conditions of sale supplied at the time of order acknowledgment.

TI warrants performance of its hardware products to the specifications applicable at the time of sale in accordance with TI's standard warranty. Testing and other quality control techniques are used to the extent TI deems necessary to support this warranty. Except where mandated by government requirements, testing of all parameters of each product is not necessarily performed.

TI assumes no liability for applications assistance or customer product design. Customers are responsible for their products and applications using TI components. To minimize the risks associated with customer products and applications, customers should provide adequate design and operating safeguards.

TI does not warrant or represent that any license, either express or implied, is granted under any TI patent right, copyright, mask work right, or other TI intellectual property right relating to any combination, machine, or process in which TI products or services are used. Information published by TI regarding third-party products or services does not constitute a license from TI to use such products or services or a warranty or endorsement thereof. Use of such information may require a license from a third party under the patents or other intellectual property of the third party, or a license from TI under the patents or other intellectual property of TI.

Reproduction of TI information in TI data books or data sheets is permissible only if reproduction is without alteration and is accompanied by all associated warranties, conditions, limitations, and notices. Reproduction of this information with alteration is an unfair and deceptive business practice. TI is not responsible or liable for such altered documentation. Information of third parties may be subject to additional restrictions.

Resale of TI products or services with statements different from or beyond the parameters stated by TI for that product or service voids all express and any implied warranties for the associated TI product or service and is an unfair and deceptive business practice. TI is not responsible or liable for any such statements.

TI products are not authorized for use in safety-critical applications (such as life support) where a failure of the TI product would reasonably be expected to cause severe personal injury or death, unless officers of the parties have executed an agreement specifically governing such use. Buyers represent that they have all necessary expertise in the safety and regulatory ramifications of their applications, and acknowledge and agree that they are solely responsible for all legal, regulatory and safety-related requirements concerning their products and any use of TI products in such safety-critical applications, notwithstanding any applications-related information or support that may be provided by TI. Further, Buyers must fully indemnify TI and its representatives against any damages arising out of the use of TI products in such safety-critical applications.

TI products are neither designed nor intended for use in military/aerospace applications or environments unless the TI products are specifically designated by TI as military-grade or "enhanced plastic." Only products designated by TI as military-grade meet military specifications. Buyers acknowledge and agree that any such use of TI products which TI has not designated as military-grade is solely at the Buyer's risk, and that they are solely responsible for compliance with all legal and regulatory requirements in connection with such use.

TI products are neither designed nor intended for use in automotive applications or environments unless the specific TI products are designated by TI as compliant with ISO/TS 16949 requirements. Buyers acknowledge and agree that, if they use any non-designated products in automotive applications, TI will not be responsible for any failure to meet such requirements.

Following are URLs where you can obtain information on other Texas Instruments products and application solutions:

Products		Applications	
Amplifiers	amplifier.ti.com	Audio	www.ti.com/audio
Data Converters	dataconverter.ti.com	Automotive	www.ti.com/automotive
DLP® Products	www.dlp.com	Communications and Telecom	www.ti.com/communications
DSP	dsp.ti.com	Computers and Peripherals	www.ti.com/computers
Clocks and Timers	www.ti.com/clocks	Consumer Electronics	www.ti.com/consumer-apps
Interface	interface.ti.com	Energy	www.ti.com/energy
Logic	logic.ti.com	Industrial	www.ti.com/industrial
Power Mgmt	power.ti.com	Medical	www.ti.com/medical
Microcontrollers	microcontroller.ti.com	Security	www.ti.com/security
RFID	www.ti-rfid.com	Space, Avionics & Defense	www.ti.com/space-avionics-defense
RF/IF and ZigBee® Solutions	www.ti.com/lprf	Video and Imaging	www.ti.com/video
		Wireless	www.ti.com/wireless-apps

Mailing Address: Texas Instruments, Post Office Box 655303, Dallas, Texas 75265
Copyright © 2010, Texas Instruments Incorporated