

January 1996

LM1205/LM1207 130 MHz/85 MHz RGB Video Amplifier System with Blanking

General Description

The LM1205/LM1207 is a very high frequency video amplifier system intended for use in high resolution RGB monitor applications. In addition to the three matched video amplifiers, the LM1205/LM1207 contains three gated single ended input black level clamp comparators for brightness control, three matched DC controlled attenuators for contrast control, and three DC controlled sub-contrast attenuators providing gain trim capability for white balance. All DC control inputs offer high input impedance and an operation range from 0V to 4V for easy interface to bus controlled alignment systems. The LM1205/LM1207 also contains a blanking circuit which clamps the video output voltage during blanking to within 0.1V above ground. This feature provides blanking capability at the cathodes of the CRT. A spot killer is provided for CRT phosphor protection during power-down.

Features

- Three wideband video amplifiers 130 MHz (LM1205) @ -3 dB (4 V_{PP} output)
- Matched (± 0.1 dB or 1.2%) attenuators for contrast control

- Three externally gated single ended input comparators for cutoff and brightness control
- 0V to 4V, high input impedance DC contrast control (>40 dB range)
- 0V to 4V, high input impedance DC drive control for each video amplifier (-6 dB to 0 dB range)
- Spot killer, blanks output when V_{CC} < 10.6V
- Capable of 7 V_{PP} output swing (slight reduction in bandwidth)
- Output stage blanking
- Output stage directly drives most hybrid or discrete CRT drivers

Applications

- High resolution RGB CRT monitors
- Video AGC amplifiers
- Wideband amplifiers with gain and DC offset controls
- Interface amplifiers for LCD or CCD systems

Block and Connection Diagram

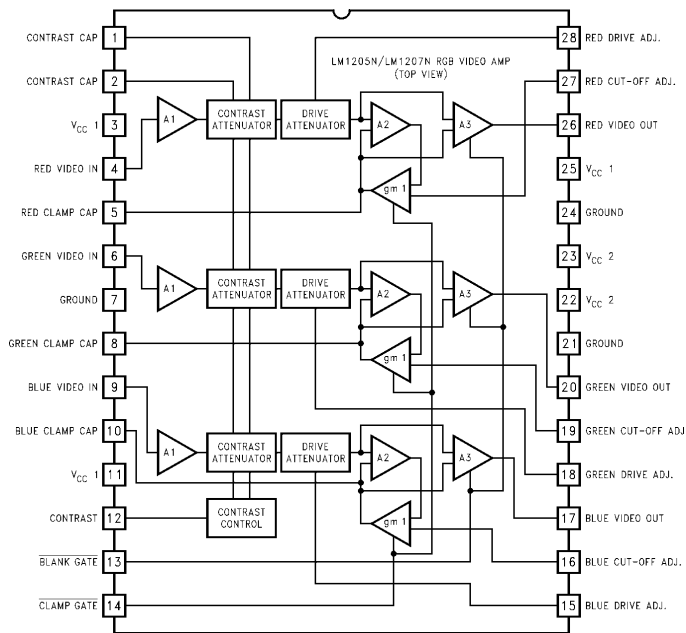

FIGURE 1

Order Number LM1205N or LM1207N
See NS Package Number N28B

TL/H/11881-1

LM1205/LM1207 130 MHz/85 MHz RGB Video Amplifier System with Blanking

Absolute Maximum Ratings (Note 1)

If Military/Aerospace specified devices are required, please contact the National Semiconductor Sales Office/Distributors for availability and specifications.

Supply Voltage (V_{CC})	15V
Pins 3, 11, 22, 23, 25 (Note 3)	
Peak Video Output Source Current	28 mA
(Any One Amp) Pins 17, 20 or 26	
Voltage at Any Input Pin (V_{IN})	$V_{CC} \geq V_{IN} \geq GND$
Power Dissipation (P_D)	2.5W
(Above 25°C Derate Based on θ_{JA} and T_J)	
Thermal Resistance (θ_{JA})	50°C/W
Junction Temperature (T_J)	150°C
ESD Susceptibility (Note 4)	2 kV
Pins 12, 13 and 14	1.9 kV
Storage Temperature	-65°C to 150°C
Lead Temperature (Soldering, 10 sec.)	265°C

Operating Ratings (Note 2)

Temperature Range	-20°C to 80°C
Supply Voltage (V_{CC})	$10.8V \leq V_{CC} \leq 13.2V$

DC Electrical Characteristics See DC Test Circuit (Figure 2), $T_A = 25^\circ\text{C}$; $V_{CC1} = V_{CC2} = 12V$. $V_{I2} = 4V$; $V_{I4} = 0V$; $V_{cut-off} = 1.0V$; $V_{I3} = 4V$; $V_{drive} = 4V$ unless otherwise stated.

Symbol	Parameter	Conditions	Typical (Note 5)	Limit (Note 6)	Units
I_S	Supply Current	$V_{CC1} + V_{CC2}$, $R_L = \infty$ (Note 7)	90	105	mA (max)
$V_{4, 6, 9}$	Video Amplifier Input Bias Voltage		2.8		V
R_{IN}	Video Input Resistance	Any One Amplifier	20		k Ω
V_{14l}	Clamp Gate Low Input Voltage	Clamp Comparators On	1.2	0.8	V (max)
V_{14h}	Clamp Gate High Input Voltage	Clamp Comparators Off	1.6	2.0	V (min)
I_{14l}	Clamp Gate Low Input Current	$V_{14} = 0V$	-1	-5	μA (max)
I_{14h}	Clamp Gate High Input Current	$V_{14} = 12V$	0.01	1.0	μA (max)
I_{clamp}	Clamp Cap Charge Current	Clamp Comparators On	± 750	± 500	μA (min)
I_{bias}	Clamp Cap Bias Discharge Current	Clamp Comparators Off	500		nA
V_{13l}	Blank Gate Low Input Voltage	Blank Gate On	1.2	0.8	V (max)
V_{13h}	Blank Gate High Input Voltage	Blank Gate Off	1.6	2.0	V (min)
I_{13l}	Blank Gate Low Input Current	$V_{13} = 0V$	-8.5	-11.0	μA (max)
I_{13h}	Blank Gate High Input Current	$V_{13} = 12V$	0.01	1.0	μA (max)
V_{OL}	Video Output Low Voltage	$V_{cut-off} = 0V$	0.15	0.5	V (max)
V_{OH}	Video Output High Voltage	$V_{cut-off} = 9V$	7.5	7	V (min)
$V_{O(1V)}$	Video Black Level Output Voltage	$V_{cut-off} = 1V$	1.0		V (Note 8)
$\Delta V_{O(1V)}$	Video Δ Black Level Output Voltage	Between Any Two Amplifiers, $V_{cut-off} = 1V$	± 100		mV (max)
$V_{OL}(\text{blanked})$	Video Output Blanked Voltage	$V_{I3} = 0V$	35	70	mV (max)
$I_{12, 15, 18 \text{ or } 28}$	Contrast/Drive Control Input Current	$V_{contrast} = V_{drive} = 0V \text{ to } 4V$	-250		nA
$I_{16, 19 \text{ and } 27}$	Cut-Off Control Input Current (All Inputs)	$V_{cut-off} = 0V \text{ to } 4V$	-500		nA
V_{spot}	Spot Killer Voltage	V_{CC} Adjusted to Activate	10.4	10.8	V (max)

AC Electrical Characteristics See AC Test Circuit (Figure 3), $T_A = 25^\circ\text{C}$; $V_{CC1} = V_{CC2} = 12\text{V}$. Manually adjust Video Output pins 17, 20, and 26 to 4V DC for the AC test unless otherwise stated. (Note 14)

Symbol	Parameter	Conditions	Typical (Note 5)	Limit (Note 6)	Units
$A_V \text{ max}$	Video Amplifier Gain	$V_{12} = 4\text{V}$, $V_{IN} = 635 \text{ mV}_{PP}$ $V_{drive} = 4\text{V}$	7.0	6.0	V/V (min)
			16.9	15.6	dB (min)
$\Delta A_V 2\text{V}$	Attenuation @ 2V	Ref: $A_V \text{ max}$, $V_{12} = 2\text{V}$	-6		dB
$\Delta A_V 0.25\text{V}$	Attenuation @ 0.25V	Ref: $A_V \text{ max}$, $V_{12} = 0.25\text{V}$	-40		dB
ΔDrive	Drive Control Range	$V_{drive} = 0\text{V to } 4\text{V}$, $V_{12} = 4\text{V}$	6		dB
$A_V \text{ match}$	Absolute Gain Match @ $A_V \text{ max}$	$V_{12} = 4\text{V}$, $V_{drive} = 4\text{V}$ (Note 9)	± 0.3		dB
$A_V \text{ track1}$	Gain Change Between Amplifiers	$V_{12} = 4\text{V to } 2\text{V}$ (Notes 9, 10)	± 0.1		dB
THD	Video Amplifier Distortion	$V_O = 1 \text{ V}_{PP}$, $f = 10 \text{ kHz}$	1		%
$f (-3 \text{ dB})$	Video Amplifier Bandwidth (Notes 11, 12)	$V_{12} = 4\text{V}$, $V_{drive} = 4\text{V}$, $V_O = 4 \text{ V}_{PP}$	LM1205	130	MHz
			LM1207	85	
$t_r(\text{Video})$	Video Output Rise Time (Note 11)	$V_O = 4 \text{ V}_{PP}$	LM1205	2.6	ns
			LM1207	4.3	
$t_f(\text{Video})$	Video Output Fall Time (Note 11)	$V_O = 4 \text{ V}_{PP}$	LM1205	3.6	ns
			LM1207	4.3	
$V_{sep} 10 \text{ kHz}$	Video Amplifier 10 kHz Isolation	$V_{12} = 4\text{V}$ (Note 13)	-70		dB
$V_{sep} 10 \text{ MHz}$	Video Amplifier 10 MHz Isolation	$V_{12} = 4\text{V}$ (Notes 11, 13)	-50		dB
$t_r(\text{Blank})$	Blank Output Rise Time (Note 11)	Blank Output = 1 V_{PP}	7		ns
$t_f(\text{Blank})$	Blank Output Fall Time (Note 11)	Blank Output = 1 V_{PP}	7		ns
$t_{pw}(\text{Clamp})$	Min. Back Porch Clamp Pulse Width		200		ns

Note 1: Absolute Maximum Ratings indicate limits beyond which damage to the device may occur.

Note 2: Operating Ratings indicate conditions for which the device is functional, but do not guarantee specific performance limits. For guaranteed specifications and test conditions, see the Electrical Characteristics. The guaranteed specifications apply only for the test conditions listed. Some performance characteristics may degrade when the device is not operated under the listed test conditions.

Note 3: V_{CC} supply pins 3, 11, 22, 23, 25 must be externally wired together to prevent internal damage during V_{CC} power on/off cycles.

Note 4: Human body model, 100 pF discharged through a 1.5 k Ω resistor.

Note 5: Typical specifications are specified at +25 $^\circ\text{C}$ and represent the most likely parametric norm.

Note 6: Tested limits are guaranteed to National's AOQL (Average Outgoing Quality Level).

Note 7: The supply current specified is the quiescent current for V_{CC1} and V_{CC2} with $R_L = \infty$, see Figure 2's test circuit. The supply current for V_{CC2} (pin 23) also depends on the output load. With video output at 1V DC, the additional current through V_{CC2} is 8 mA for Figure 2's test circuit.

Note 8: Output voltage is dependent on load resistor. Test circuit uses $R_L = 390\Omega$.

Note 9: Measure gain difference between any two amplifiers. $V_{IN} = 635 \text{ mV}_{PP}$.

Note 10: $\Delta A_V \text{ track}$ is a measure of the ability of any two amplifiers to track each other and quantifies the matching of the three attenuators. It is the difference in gain change between any two amplifiers with the contrast voltage (V_{12}) at either 4V or 2V measured relative to an $A_V \text{ max}$ condition, $V_{12} = 4\text{V}$. For example, at $A_V \text{ max}$ the three amplifiers' gains might be 17.1 dB, 16.9 dB and 16.8 dB and change to 11.2 dB, 10.9 dB, and 10.7 dB respectively for $V_{12} = 2\text{V}$. This yields the measured typical ± 0.1 dB channel tracking.

Note 11: When measuring video amplifier bandwidth or pulse rise and fall times, a double sided full ground plane printed circuit board without socket is recommended. Video amplifier 10 MHz isolation test also requires this printed circuit board. The reason for a double sided full ground plane PCB is that large measurement variations occur in single sided PCBs.

Note 12: Adjust input frequency from 10 MHz ($A_V \text{ max}$ reference level) to the -3 dB corner frequency ($f_{-3 \text{ dB}}$).

Note 13: Measure output levels of the other two undriven amplifiers relative to the driven amplifier to determine channel separation. Terminate the undriven amplifier inputs to simulate generator loading. Repeat test at $f_{IN} = 10 \text{ MHz}$ for $V_{sep} 10 \text{ MHz}$.

Note 14: During the AC tests the 4V DC level is the center voltage of the AC output signal. For example, if the output is 4 V_{PP} the signal will swing between 2V DC and 6V DC.

Typical Performance Characteristics $V_{CC} = 12V, T_A = 25^\circ C$ unless otherwise specified

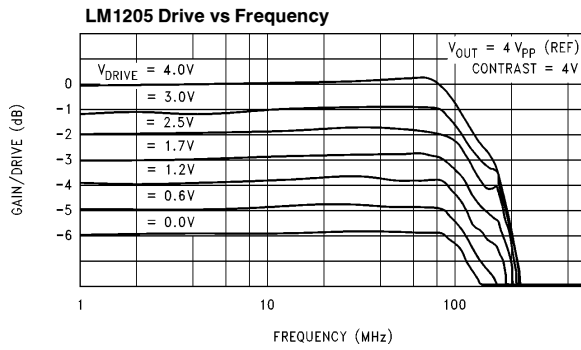
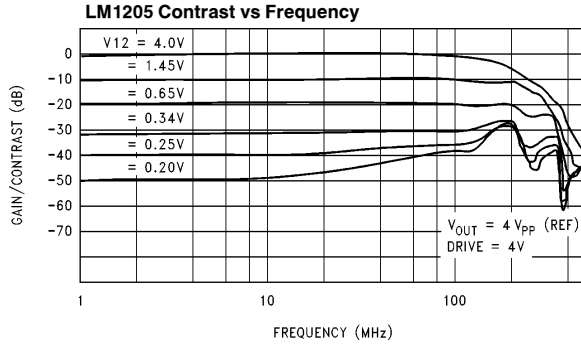
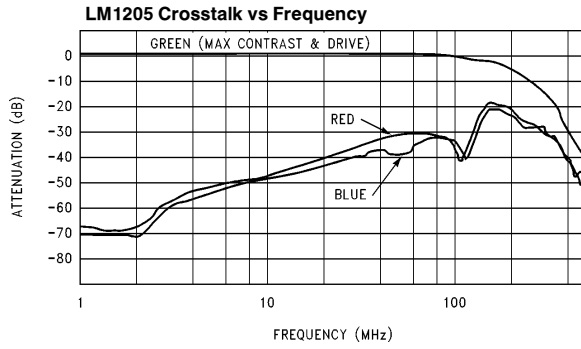
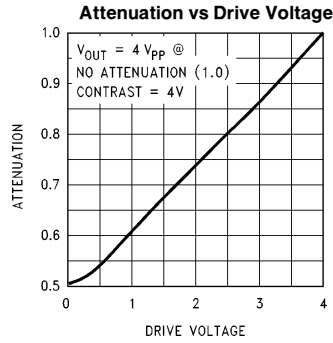
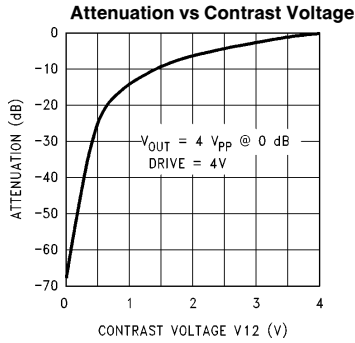

Typical Performance Characteristics $V_{CC} = 12V$, $T_A = 25^\circ C$ unless otherwise specified (Continued)

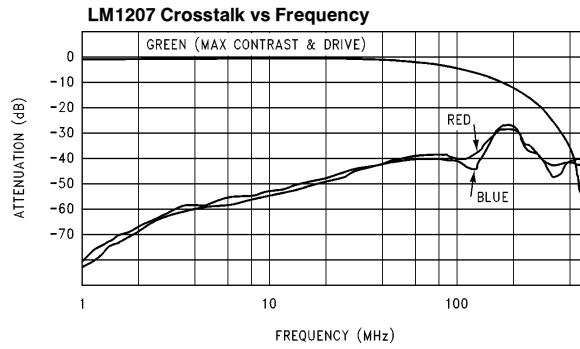

TL/H/11881-7

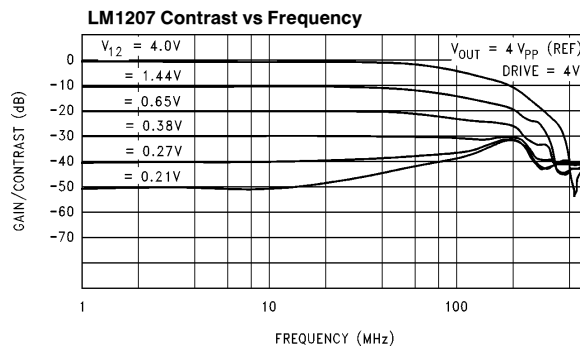

TL/H/11881-8

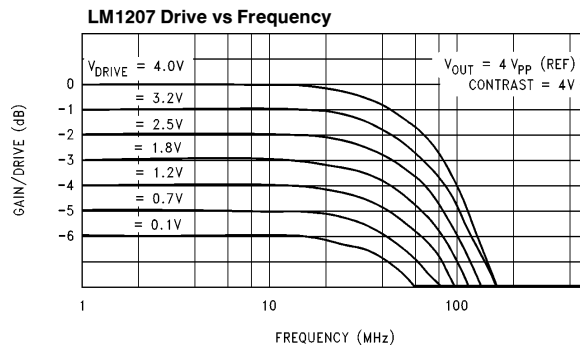

TL/H/11881-9

Applications Information (Continued)

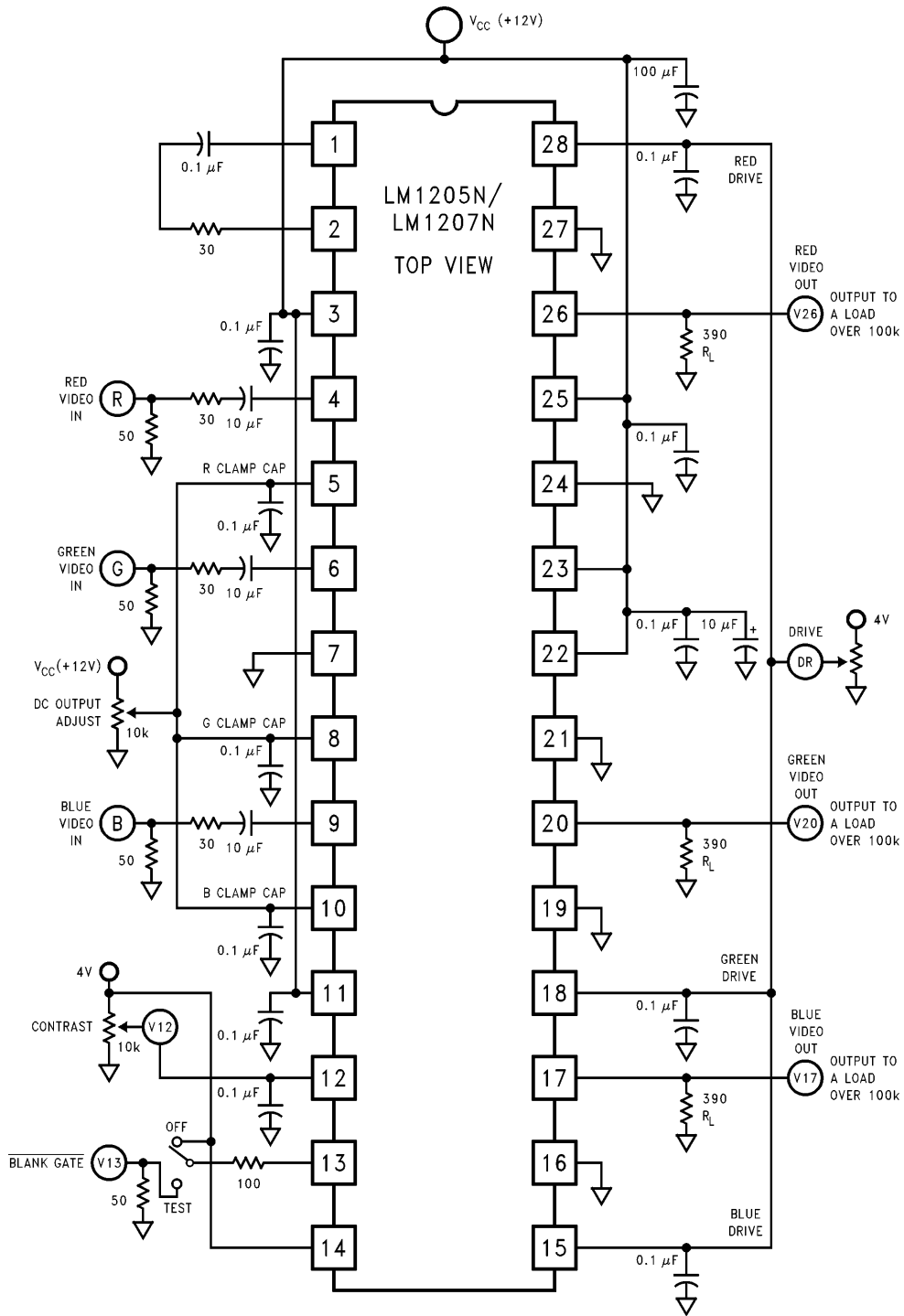
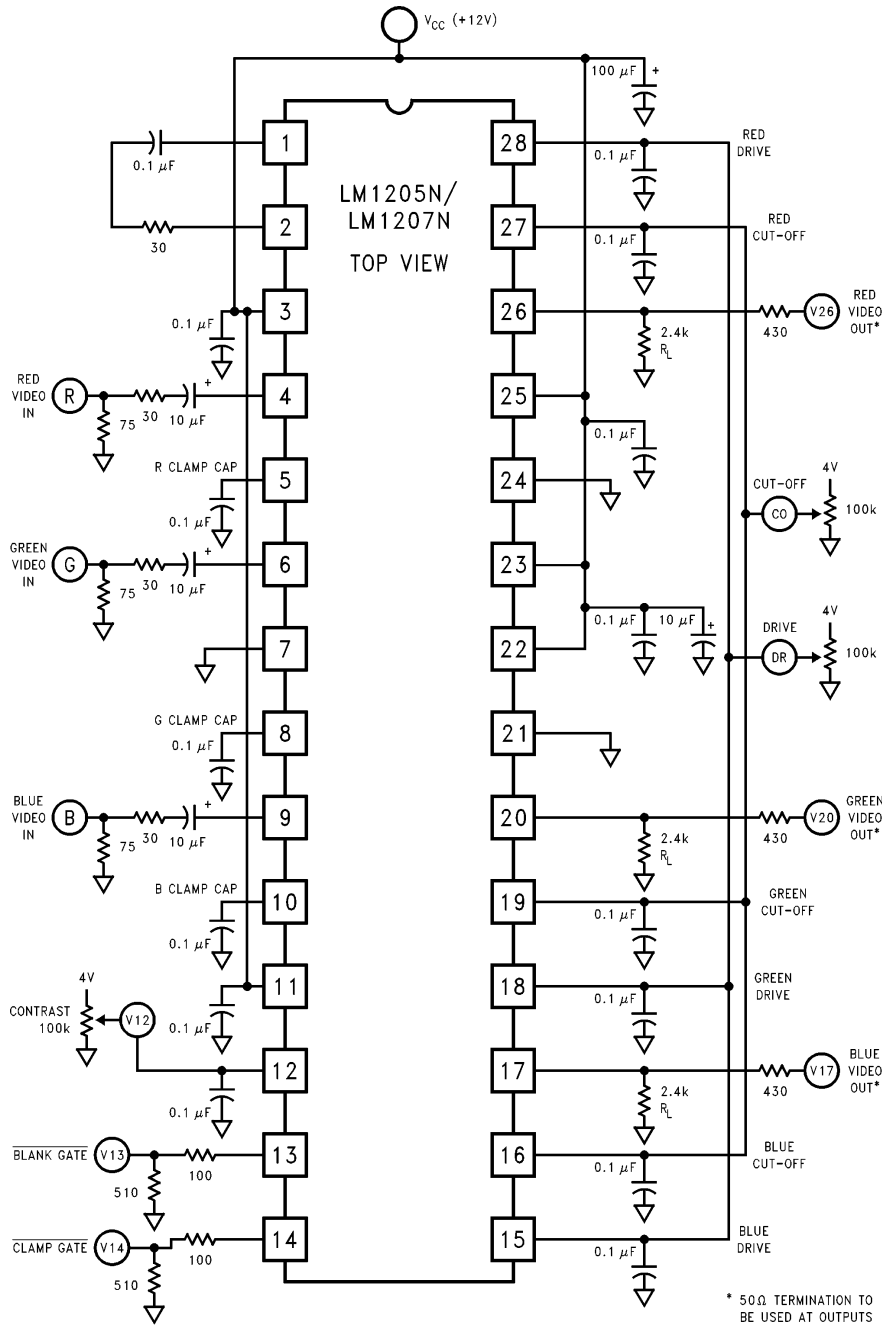

FIGURE 3. LM1205N/LM1207N AC Test Circuit

TL/H/11881-11

Applications Information (Continued)



* 50 Ω TERMINATION TO BE USED AT OUTPUTS

TL/H/11881-12

FIGURE 4. LM1205N/LM1207N PCB Test Circuit

Applications Information (Continued)

Figure 5 shows the block diagram of a typical analog RGB color monitor. The RGB monitor is used with CAD/CAM work stations, PC's, arcade games and in a wide range of other applications that benefit from the use of color display terminals. The RGB color monitor characteristics may differ in such ways as sweep rates, screen size, CRT color trio spacing (dot pitch), or in video amplifier bandwidths but will still be generally configured as shown in Figure 5. Separate horizontal and vertical sync signals may be required or they may be contained in the green video input signal. The video input signals are usually supplied by coax cable which is terminated into 75Ω at the monitor input and internally AC coupled to the video amplifiers. These input signals are approximately 1V peak to peak in amplitude and at the input of the high voltage video section, approximately 5V peak to peak. At the cathode of the CRT the video signals can be as high as 60V peak to peak. One important requirement of the three video amplifiers is that they match and track each other over the contrast and brightness control range. The Figure 5 block labeled "VIDEO AMPLIFICATION WITH GAIN AND DC CONTROL" describes the function of the LM1205/LM1207 which contains the three matched video amplifiers, contrast control and brightness control. The LM1205/LM1207 also provides the capability to blank at the cathode of the CRT.

Functional Description

Figure 6 is a detailed block diagram of the green channel of the LM1205/LM1207 along with the recommended external components. The IC pin numbers are circled and all external components are shown outside the dashed line. The other two video channels are identical to the green channel, only the numbers to the pins unique to each channel are different. The input video is normally terminated into 75Ω. The

termination resistor depends on the impedance of the coax cable being used, 75Ω being the most common impedance used in video applications. The video signal is AC coupled through a 10 μF capacitor to the input, pin 6. There is no standard for the DC level of a video signal, therefore the signal must be AC coupled to the LM1205/LM1207. Internal to the LM1205/LM1207 is a 2.8V reference, giving the input video an offset voltage of 2.8V. This voltage was selected to give the input video enough DC offset to guarantee that the lowest voltage of the video signal at pin 6 is far enough above ground to keep the LM1205/LM1207 in the active region. The 200Ω resistor at the input is for ESD protection and for current limiting during any voltage surge that may occur at the input, driving pin 6 above V_{CC}. The input video signal is buffered by -A1. In this circuit description an inverting amplifier is shown with a "-" (minus sign) in front of the amplifier designation. The output of -A1 goes to the contrast and drive attenuator sections.

The contrast and drive control sections are virtually identical. Both sections take a 0V to 4V input voltage, 4V giving the maximum gain for either the contrast or the drive. This is a high impedance input, allowing for an easy interface to 5V DACs. One may also use 100k potentiometers with no degradation in performance. The contrast control section is common to all three channels. It converts the input voltage at pin 12 to a couple of internal DC voltages that control the gain of the contrast attenuator. Referring to the Attenuation vs Contrast Voltage under typical performance characteristics note that a 4V control voltage results in no attenuation of the video signal. A 0.25V control voltage results in an attenuation of 40 dB. Again note that these internal control voltages are common to all three channels. To minimize crosstalk, these voltages go to pins 1 and 2. Minimizing crosstalk is done by adding the RC network shown in the block diagram (Figure 6).

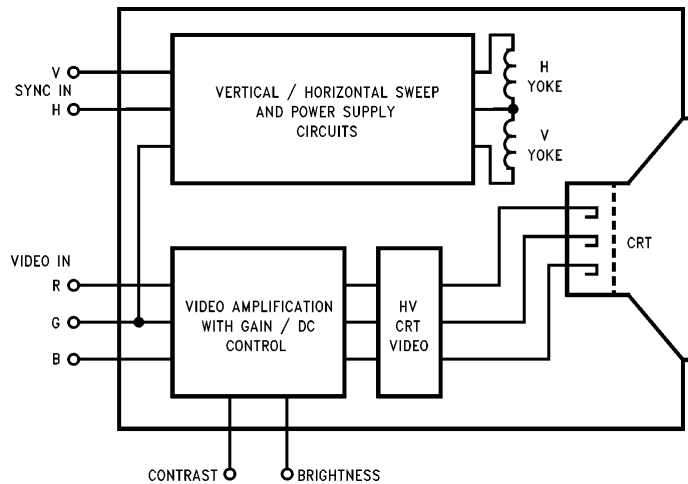

FIGURE 5. Typical RGB Color Monitor Block Diagram

TL/H/11881-13

Functional Description (Continued)

The 0V to 4V drive control signal comes in on pin 18. Each channel has its own drive section, therefore the crosstalk compensation needed for the contrast control voltages is not required for the drive control, thus no external pins for the drive control. The drive attenuator gives an attenuation range from 0 dB to -6 dB. A small gain adjustment range for the drive attenuator is desirable and intentionally designed because the drive is used only to balance the overall gain of each color channel, giving the correct color temperature on the CRT.

The output of the drive attenuator stage goes to A2, the amplifier in the DC restoration section. The video signal goes to the non-inverting input of A2. The inverting side of A2 goes to the output of gm1, the clamp comparator, and the clamp capacitor at pin 8.

During the back porch period of the video signal a negative going clamp pulse from pin 14 is applied to the clamp comparator, turning on the comparator. This period is where the black level of the video signal at the output of the LM1205/LM1207 is compared to the desired black level which is set at pin 19. *Figure 7* shows the timing of the clamp pulse relative to the video signal. The clamp capacitor is charged or discharged by gm1, generating the correction voltage needed at the inverting input of A2 to set the video output to the correct DC level. Removing the clamp pulse turns off gm1 with the correction voltage being maintained by the clamp capacitor during active video. Both the clamp pulse and the blank pulse at pin 13 are TTL voltage levels.

There are actually two output sections, -A3 and -A4. Both sections have been designed to be identical, except -A4 has more current drive capability. The output transistor shown is part of -A4, but has been shown separately so the user knows the configuration of the output stage. -A3 does not go to the outside world, it is used for feeding back the video signal for DC restoration. Its output goes directly

to the inverting input of the clamp comparator via the voltage divider formed by the 500 Ω and 4k resistors. -A4 will be close to the same output as -A3 and will temperature track due to the similar design of the two output stages. However, the current at the output of -A4 will be ten times the current at the output of -A3. To balance both outputs, a load resistance of 390 Ω needs to be connected from pin 20, the green video output pin, to ground. Another input to -A4 is the blank pulse. When a negative going blank pulse is applied to pin 13, the output of the LM1205/LM1207 is driven to less than 0.1V above ground. Using the timing shown in *Figure 7* for the blank pulse, the output of the LM1205/LM1207 will be less than 0.1V during the inactive portion of the video signal. This is a "blacker than black" condition, blanking the CRT at the cathodes. By using the blank function of the LM1205/LM1207 no grid blanking is necessary. Note that the DC restoration is done by feeding back the video signal from -A3, but blanking is done at -A4. By using the two output stages, blanking can be done at the CRT cathodes, and at the same time activate the DC restoration loop.

V_{CC1} goes to pins 3, 11, and 25 (see *Figure 1*). These three pins are all internally connected. For proper operation of the LM1205/LM1207 it is necessary to connect **all** the V_{CC1} pins to the input power to the PCB and bypass each pin with a 0.1 μ F capacitor. V_{CC2} is the input power at pins 22 and 23 for the three output stages. This is a separate power input from V_{CC1}, there are no internal connections between the two different power inputs. There must be a connection on the PCB between V_{CC1} and V_{CC2}. Pins 22 and 23 must be bypassed by a parallel connection of a 10 μ F and 0.1 μ F capacitors. The ground connections for the LM1205/LM1207 are at pins 7, 21, and 24. All three ground pins are internally connected, and these pins must also be connected externally to a good ground plane for proper operation of the LM1205/LM1207.

Functional Description (Continued)

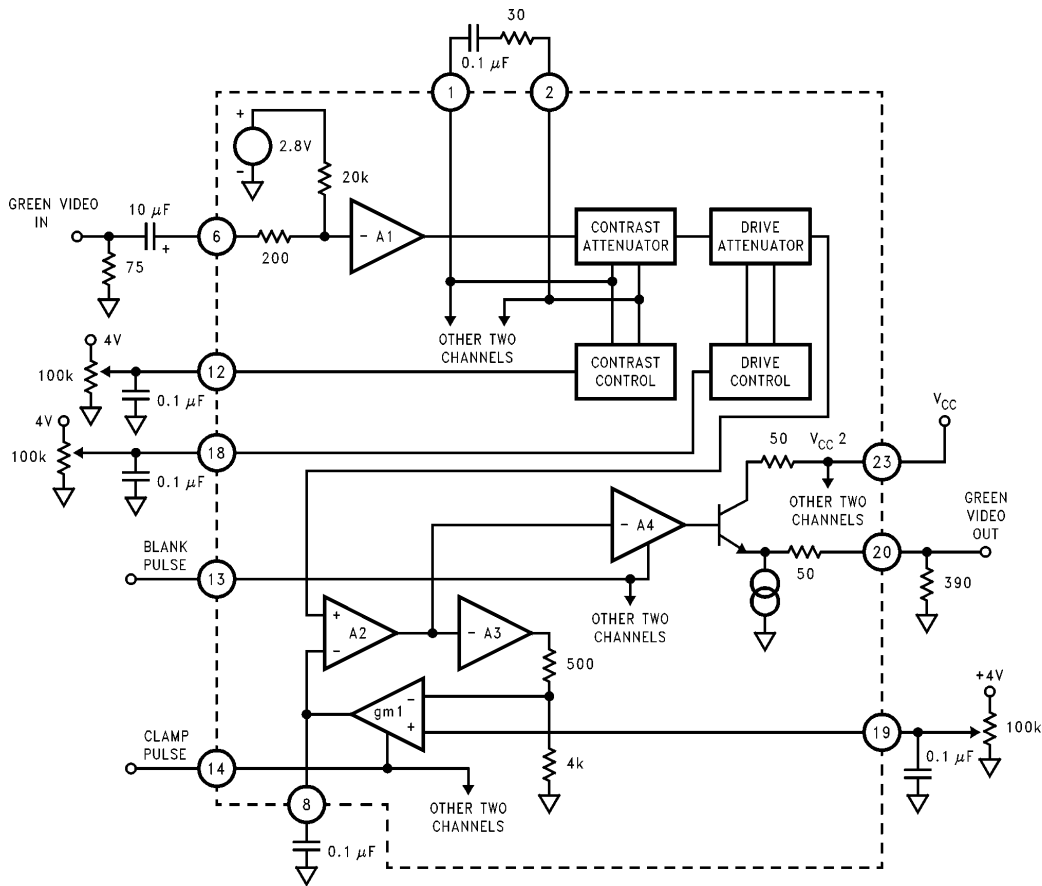

FIGURE 6. Block Diagram of LM1205/LM1207 Video Amplifier

TL/H/11881-14

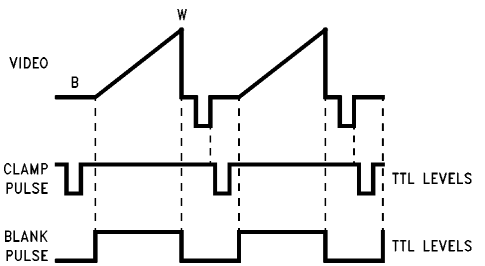

FIGURE 7. Timing Diagram

TL/H/11881-15

Circuit Description

VIDEO AMPLIFIER INPUT STAGE

Figure 8 is a simplified schematic of one of the three video amplifiers input stage along with the recommended external components. The IC pin numbers are circled and all external components are shown outside the dashed line. The video

input is applied to pin 6 via a 10 μF coupling capacitor and a 30Ω resistor. The resistor is added to limit the current through the input pin should an applied voltage surge rise above V_{CC} or drop below ground. The performance of the LM1205/LM1207 is not degraded by the 30Ω resistor. However, if EMI is a concern this resistor can be increased to well over 100Ω where the rise and fall times will start to become longer. DC bias to the input pin is provided by Q5 and its associated input circuitry. Z1 is a 5.6V zener that generates the input bias voltage. Q1 is a buffer to the zener reference voltage with 5.0V generated at its emitter. Q3 and Q4 are connected as diodes. Q2 is close to being a diode in this circuit. This configuration will give about 2.0V at the collector of Q2. R2 and R3 are a voltage divider, setting the base of Q5 to about 3.5V. This sets the emitter of Q5 to about 2.8V, the bias voltage of the video input. This bias voltage is necessary to assure that the entire video signal stays within the active operating region of the LM1205/LM1207. The bias voltage goes through R6, a 20k resistor, to the video input at pin 6. R4 and R6 are of the same value

Circuit Description (Continued)

and R4 is used to compensate for beta variations of the transistors. Note that the bias voltage passes through three diode drops (Q5, Q6, and Q7) before setting the voltage across R9. Q2, Q3, and Q4 also provide three diode drops to the bias voltage at the base of Q5, temperature compensating for the diode drops of Q5, Q6, and Q7. This insures that the bias voltage across R9 remains very constant over temperature, providing an accurate bias current for the differential transistor pair Q8 and Q9, thus assuring proper operation of the contrast control.

Q6 serves as a buffer to the input video signal. Its emitter drives the base of Q7. Thus the video signal modulates the current flowing through R9, which in turn modulates the currents through the differential pair formed by Q8 and Q9. The current flow through Q8 and Q9 is controlled by a DC voltage from the Contrast Control circuit. This DC voltage is common to all three channels. Increasing the voltage to the base of Q9 with respect to the base of Q8 increases the current flow through Q9. A higher current flow through Q9 increases the video gain (contrast) of the LM1205/LM1207. Q10 and Q11 also form a differential pair at the collector of Q9. The operation of this differential pair is similar to Q8 and Q9. The DC control voltage is from the Drive Control cir-

cuits. Each channel has its own drive control circuit. Increasing the voltage to the base of Q11 increases the video gain (drive) of the LM1205/LM1207. R10 and R11 are of the same value, but R10 is common to both Q10 and Q11. If all the current is flowing through Q10, the video amplitude would only be half of the maximum gain (all current flowing through Q11). This gives the drive control a total gain adjustment range of 6 dB. Since the drive control is only used to balance the color of each channel a small adjustment range is desirable. Q12 through Q17 are part of the final section shown in Figure 8. DC restoration is done at this stage. The clamp comparator (Figure 11) drives the clamp cap at pin 8 to a voltage that sets the correct black level of the video signal. This cap is also connected to the base of Q17. Q17 and Q16 are one half of the darlington differential pair. The clamp cap voltage establishes the current flow through R16, Q15, and R15. With the bases of Q14 and Q15 held to the same voltage the current through Q15 is mirrored into Q14 and the other half of the differential pair, Q12 and Q13. By this current mirror the voltage at the collector of Q14 is set to the correct DC value for the video signal by controlling the voltage drop across R13, completing the DC restoration.

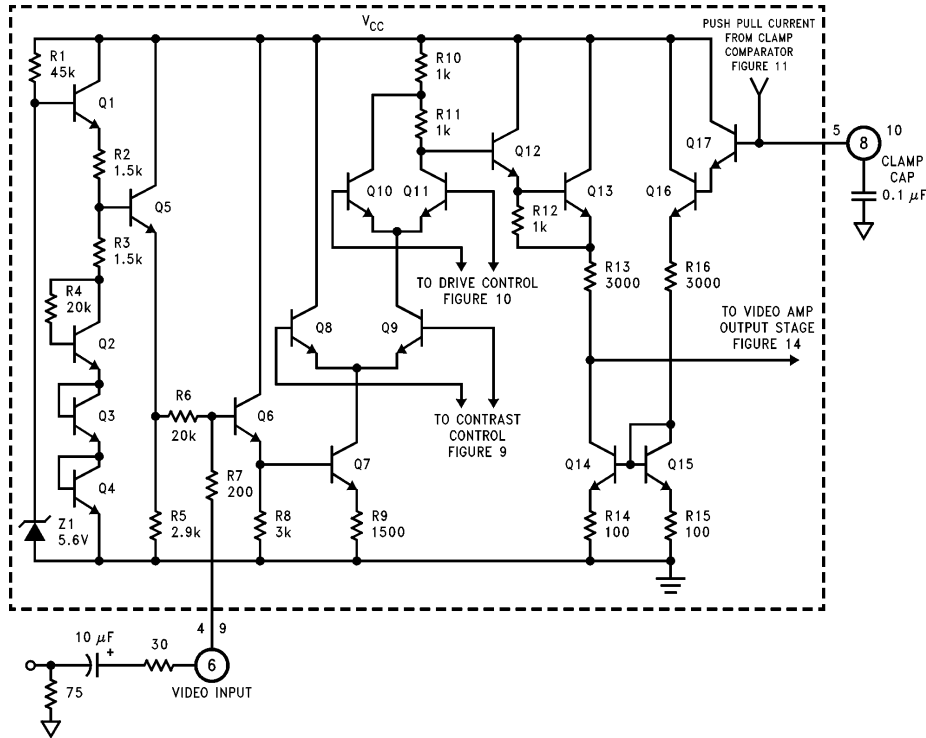

FIGURE 8. Simplified Schematic of LM1205/LM1207 Video Amplifier Input Stage

TL/H/11881-16

Circuit Description (Continued)

CONTRAST CONTROL

Figure 9 is a simplified schematic of the Contrast Control circuit. The output of this circuit is common to all three channels. A reference voltage is generated by Z2, Q34, Q35, R30, and R31. Q36, Q39, and Q41 are all current sources that are controlled by the reference voltage. The contrast signal has a 0V to 4V range with its input at pin 12. R32 is used for current limiting any voltage surge that may occur at pin 12. Note that the input stage (Q37, Q38, and Q42) are all PNP transistors. This configuration is necessary for operation down to near ground. At Q44 the input voltage is converted to a current by R33. The input stage will apply the same voltage across R33 as is applied at the input and with no temperature variations from the transistors. Q37 is connected to a current source (Q36) to keep a constant current flow through Q37 and a predictable diode voltage for the base-emitter of Q37. Q40 is connected as a diode and is biased by the current source Q39. The current through Q40 is mirrored into Q43, giving a current bias for Q42. Again this is done to give a predictable diode voltage for Q42. Q41 is a current source for both Q38 and Q42. With the current through Q42 already established, the rest of the current from Q41 flows through Q38. As one can see the input voltage is accurately reflected across R33 with no temperature coefficients from the input stage of the contrast control circuit.

Pin 1 of the contrast control output is held at a constant voltage two diode drops below $\frac{1}{2}V_{CC}$. To generate this reference the base of Q51 is held at exactly $\frac{1}{2}V_{CC}$. R44 and R45 form a voltage divider. With both Q53 and Q54 connected as diodes the voltage at the junction of R44 and R45 is $\frac{1}{2}V_{CC}$ plus one diode drop. Q52 is a buffer to this reference voltage, generating exactly $\frac{1}{2}V_{CC}$ at its emitter. Q51 is used to drive the bases of Q49 and Q50 to one diode drop below the reference voltage. Q50 is used to further buffer the reference voltage to the base of Q9 (see *Figure 8*) and the corresponding transistors in the other channels. Q48 is used to bias the collector of Q49 to $\frac{1}{2}V_{CC}$, the same voltage as the collector of Q47 when the differential pair is balanced. This keeps the characteristics of Q47 and Q49 well matched. Going back to Q44 and R33; these parts set up a current source that varies the current through R36. With a 2V contrast voltage the differential pair is balanced, meaning that the voltage drop across R36 is $\frac{1}{2}V_{CC}$. Q45 buffers the voltage at R36, driving the bases of Q46 and Q47. Q46 further buffers the voltage, driving the base of Q8 (see *Figure 8*) and the corresponding transistors in the other two

channels. In the balanced condition the voltage at pin 2 will also be two diode drops below $\frac{1}{2}V_{CC}$, giving a well balanced drive to the differential pair consisting of Q8 and Q9 in the video amplifier input stage. With the contrast voltage set to 0V, the voltage at pin 2 will increase by about 400 mV to 500 mV. A 4V contrast voltage decreases the voltage at pin 2 by about 400 mV to 500 mV from the balanced condition. Reviewing *Figure 8* note that decreasing the voltage at pin 2 will decrease the current flow through Q8. Thus the current flow through Q9 increases, increasing the gain of the LM1205/LM1207. So increasing the contrast control voltage at pin 12 increases the gain of the LM1205/LM1207. The contrast control voltage from Q46 and Q50 is common to all three channels. To minimize crosstalk it is necessary to add a decoupling capacitor of 0.1 μ F across R37 and R40. Since this can only be done externally, these two nodes are brought out to pins 1 and 2. The 30 Ω resistor is added in series with the capacitor for improving stability. To prevent a destructive current surge due to shorting either pins 1 or 2 to ground R38 was added for current limiting.

DRIVE CONTROL

Figure 10 is a simplified schematic of the Drive Control circuit. Each channel has its own drive control circuit. This circuit is almost identical to *Figure 9*, the contrast control circuit. It will be easier to cover the differences between the two circuits instead of going through virtually the same circuit description. Note that the input stage is **exactly** the same. The generation of the reference voltage at the right hand side of *Figure 10* is slightly different than the circuit in *Figure 9*. In the drive control circuit the reference voltage at the base of Q72 is to be $\frac{2}{3}V_{CC}$. In the contrast control circuit the reference voltage at the base of Q51 was to be $\frac{1}{2}V_{CC}$. To generate the $\frac{2}{3}V_{CC}$ R57 and R58 form a 2 to 1 voltage divider. With the two to one ratio it is now necessary to have three transistors connected as diodes, which are Q74, Q75, and Q76. Q73 is the buffer for this voltage divider and its emitter is exactly $\frac{2}{3}V_{CC}$ with temperature compensation. R52 and R53 also differ from their corresponding resistors in *Figure 9*, R36 and R39. The value difference is so the base of Q66 is also at $\frac{2}{3}V_{CC}$ when the input drive voltage is at 2V. R38 in *Figure 9* was needed for current limiting at the output pins. Since each channel has its own drive control circuit no filtering is required, eliminating the need for external pins. With no external pins no current limiting is necessary, thus the 1k resistor is not used in the drive control circuit.

Circuit Description (Continued)

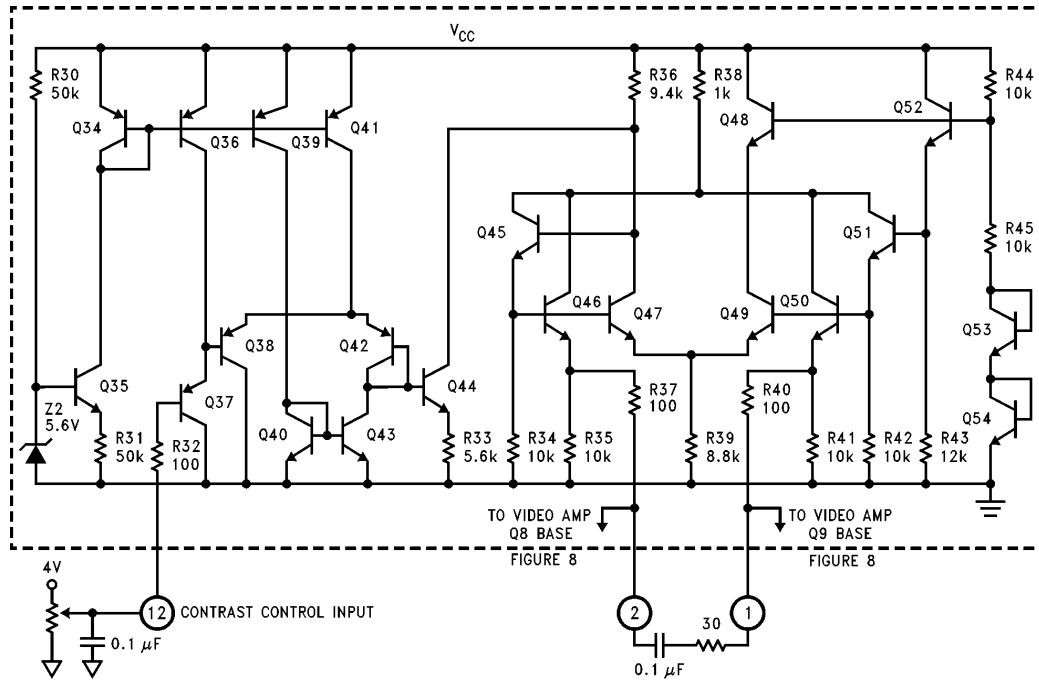

FIGURE 9. Simplified Schematic of LM1205/LM1207 Contrast Control

TL/H/11881-17

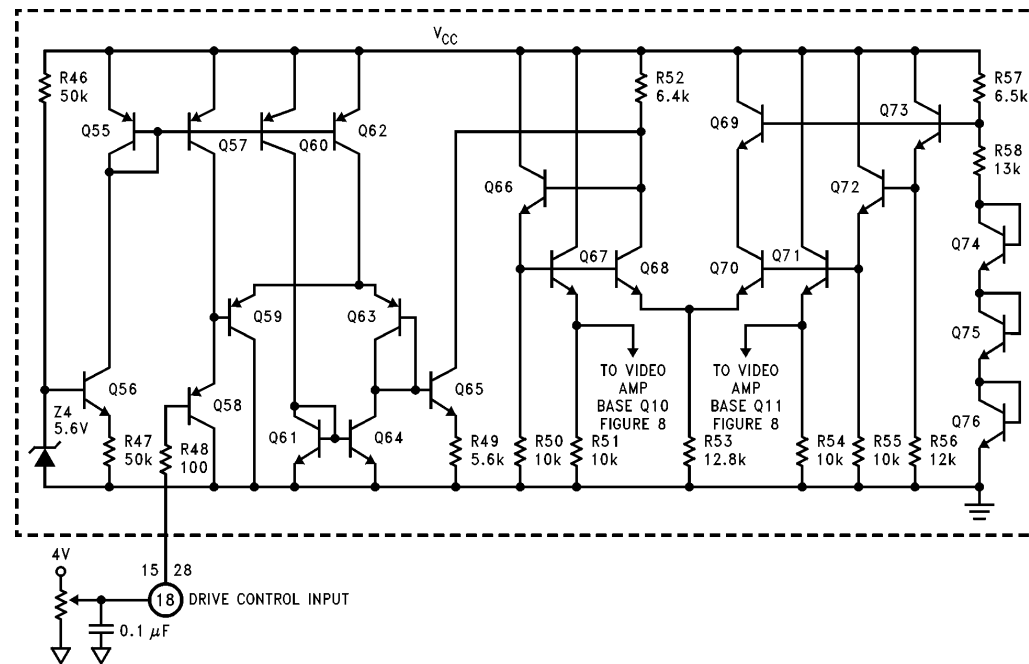

FIGURE 10. Simplified Schematic of LM1205/LM1207 Drive Control

TL/H/11881-18

Circuit Description (Continued)

CLAMP COMPARATOR CIRCUIT

Figure 11 is a simplified schematic of the clamp comparator circuit. Q85 and its input transistors, Q81 and Q82 are one half of the differential pair. The base of Q81 is connected to pin 19 via R62. This is the positive input to the comparator. Q88 and its input transistors, Q90 and Q91 are the other half of the differential pair. The base of Q92 is connected to the junction of R19 and R20 in Figure 14 via R73. This is the negative input to the comparator. R73 is included only to match the input characteristics of the positive input, which requires the 100Ω resistor. The negative comparator input is the feedback from the output stage as briefly described in the block diagram and covered in more detail in the output stage circuit description. Q86 is the current source for the differential pair. It is turned on and off by the output of the clamp gate circuit (Figure 12). Q102 of the clamp gate circuit has a current flow of about 225 μA when it is turned on. This current is mirrored into Q86. Assume that the inputs to the comparator are equal, making the differential pair balanced. In this condition Q85 and Q88 each have a current flow of 113 μA. Looking at the Q85 side of the circuit, Q84 will also have 113 μA of current flow. Q80 is set up as a current mirror to Q84, but its emitter resistor is one fourth the emitter resistance of Q84. Thus the current flow for Q80 is four times the current flow thru Q84, or 450 μA. Q83 has been added to help drive the base of Q80, increasing the accuracy of the current mirror. The collector of Q80 directly charges the capacitor as a current source of 450 μA. R65 is added to discharge the charge stored in the bases of Q80 and Q84. This is necessary to quickly turn off the current charge of the clamp capacitor as the comparator section is turned off. Q87, Q89, and Q90 work in exactly the same way. However, the collector of Q91 drives another current mirror with the 450 μA. This current flows thru Q78. Q77 is a current mirror with Q78, thus 450 μA also flows thru Q77. Q79 has been added to help drive the base of Q77, again adding to the accuracy of the current mirror. Since Q77 is on the ground side of the circuit it discharges the clamp

capacitor with 450 μA. In this balanced condition the charge and discharge current are equal, thus the voltage across the clamp capacitor remains unchanged.

Going back to the input stages, note that both inputs, Q81 and Q92, are driven by a 50 μA current source. This keeps both transistors turned on even when the differential pair, Q85 and Q88, is turned off. Q82 and Q90 are added to help drive the bases of Q85 and Q88 respectively. R64 and R72 are added to help discharge the charge stored in the bases of Q85 and Q88 as these two transistors are turned off. Since the input stage remains active the differential pair is quickly turned off. The comparator can also be more quickly turned on with the input stages remaining active. R67 is used to assure that the potential difference across the differential pair is minimal during turnoff. Without R67 there could be a little extra charge or discharge of the clamp capacitor during turnoff, creating an error in the black level of the video signal. Now assume that the input to pin 19 is slightly higher than the reference voltage to the negative input of the comparator. The voltage at the base of Q85 is now higher than the base of Q88. This creates an increased current flow thru Q85 and an equal decrease of current flow thru Q88. This current change is multiplied by four in the increase of current flow thru Q80. Likewise the current flow thru Q77 and Q91 is decreased by four times the current change in Q88. In the extreme case the current flow thru Q80 can increase to 900 μA and there would be no current flow thru Q77. Q80 does charge the clamp capacitor, thus the voltage across the capacitor will increase. The above is all reversed when the input to Q92 rises above the input level of Q81. If the base of Q86, the current source to the differential pair, is forced close to ground, then there is no current flow thru Q86 and the differential pair, Q85 and Q88. With the current flow thru the differential pair set the zero, all the current mirrors would also have no current flow. Thus the voltage on the clamp capacitor would remain constant, the desired result during active video.

Circuit Description (Continued)

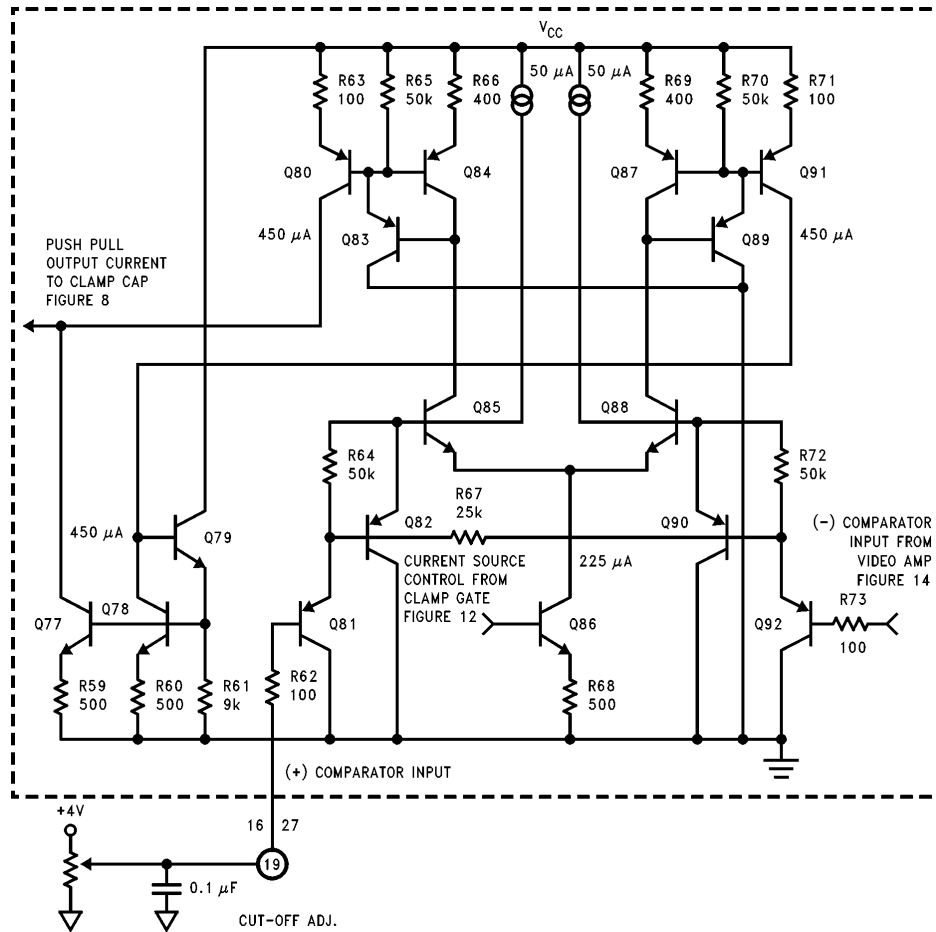

FIGURE 11. Simplified Schematic of LM1205/LM1207 Clamp Comparator Circuit

TL/H/11881-19

CLAMP GATE CIRCUIT

Figure 12 is a simplified schematic of the Clamp Gate circuit. A voltage reference is setup by Z3 and by Q104 and Q105 connected as diodes, generating a 7V base drive to Q94, Q99 and Q101. Q94 is used to bias the input stage. This stage is designed to accept TTL levels at pin 14. Q95 and Q97 form a differential pair. The base of Q97 is set to 2.1V by Q99 driving the voltage divider formed by R77 and R78. In a balanced condition the base of Q95 is also at 2.1V. Q96 is connected as a diode and the current flow thru it is mirrored into Q98. Also the input to pin 14 would be one diode drop below 2.1V, or around 1.4V. R74 is added to the

input for current limiting during any possible voltage surge at pin 14. With no resistors at the emitters of Q96 and Q98 this circuit will quickly switch. Below 1.4V (1.2V typical) Q95 is turned on and Q97 is turned off. Above 1.4V (1.6V typical) Q97 is turned on and Q95 is turned off. With Q97 turned on Q100 is also turned on. This pulls the current thru R79 to ground, turning off Q102 and Q103. Remember Q102 is a current mirror to Q86 in the clamp comparator. With Q102 turned off, the clamp comparator is also turned off. When the input signal goes below 1.2V, Q97 and Q100 will be turned off. This allows Q102 to turn on, turning on the clamp

Circuit Description (Continued)

comparators of the three video channels. Q103 is added to help drive the base of Q86 in the clamp comparator, increasing the accuracy of the current mirror. Q101 drives R79 and R80. This sets the current thru Q102, thus setting the current thru Q86 of the clamp comparator.

BLANK GATE CIRCUIT

Figure 13 is a simplified schematic of the Blank Gate circuit. With the exception of the simple output stage and the spot killer circuit, this circuit is almost identical to the clamp gate circuit. The only difference is that the output stage is driven from the opposite side of the differential pair. Thus Q111 is connected as a diode instead of Q109. With the input at pin 13 at a low level Q108 is turned on, also turning on Q29, the output transistor. Q29 is part of the blanking circuit in the output stage shown in Figure 14. When Q29 is turned on the output is clamped to a blanking level that is "blacker than black", allowing blanking to be done on the cathodes of the CRT.

The spot killer circuit is used to force the outputs of the LM1205/LM1207 into blanking when the V_{CC} drops below 10.6V. Forcing the outputs to a blacker-than-black level will

drive the cathode driver stage well above the black level, cutting off the beam current in the CRT. This prevents the bright spot from occurring when the monitor is turned off, preserving the phosphor of the CRT. The CRT will also have its beam current cut off during the time the monitor is first turned on. This is not a critical period for the CRT since the filaments have not warmed up to generate a current flow.

The comparator along with R89, R90, and Q115 all form the spot killer circuit. Q115 acts the same as Q106. When Q115 has a high signal at its base it is turned off and the outputs of the LM1205/LM1207 are in the normal operating mode. A low signal at the base of Q115 turns on this transistor, blanking the outputs of the LM1205/LM1207. Q115 is driven by the output of the comparator. The inverting input of the comparator is connected to an internal 1.2V reference. The non-inverting side is connected to a resistor divider network, R89 and R90. When V_{CC} is above 10.6V the non-inverting input is above the 1.2V reference, therefore the output of the comparator is high. This high output turns off Q115. Once the V_{CC} drops below 10.6V the comparator's output goes low, turning on Q115 which forces the outputs into the blanking mode.

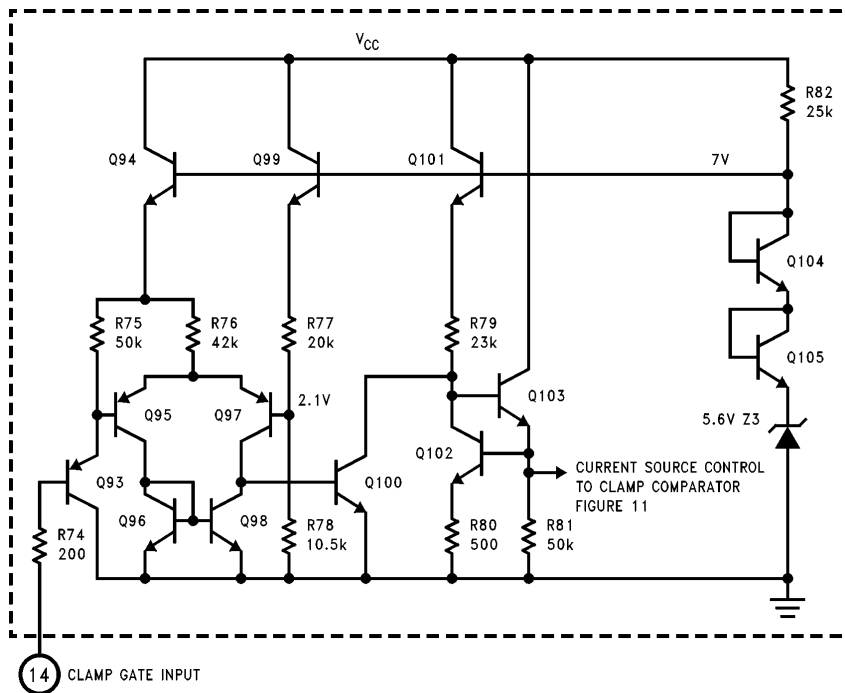

FIGURE 12. Simplified Schematic of LM1205/LM1207 Clamp Gate Circuit

TL/H/11881-20

Circuit Description (Continued)

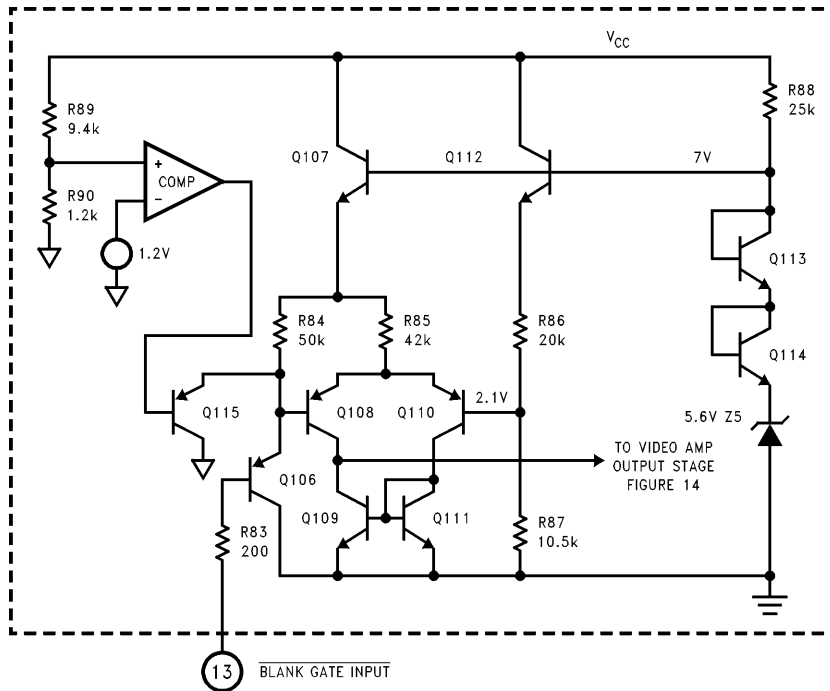

FIGURE 13. Simplified Schematic of LM1205/LM1207 Blank Gate Circuit

TL/H/11881-21

VIDEO AMPLIFIER OUTPUT STAGE WITH BLANK CIRCUIT

Figure 14 is a simplified schematic of the Video Amplifier Output Stage including the blanking circuit. Q18 serves as a buffer between the DC restoration stage shown in Figure 8 and the output stage. A current source is used to fix the current flow thru Q18 keeping it well within its operating range. The emitter of Q18 drives the bases of Q19 and Q24 with the current thru Q24 being twice that of Q19. Q19, along with Q20 thru Q23 duplicate the actual output stage going to pin 20. Q19 inverts the video signal (note that the video signal was inverted at Q7 in Figure 8). With two internal inversions of the video signal in the LM1205/LM1207, the output is non-inverted. The collector of Q19 gives a gain of -10 to the video signal and drives the base of Q20. Q21 through Q23 are all connected as diodes with the emitter of Q23 driving R19 and R20. The junction of R19 and R20 is connected to the base of Q92 via R73 (shown in Figure 11), this being the feedback to the negative input of the clamp comparator. This stage is independent of the actual output stage at pin 20, but is where the feedback is done for DC restoration. Therefore it is possible to blank the actual output stage below the black level without affecting the DC restoration feedback loop. Q24 is the equivalent part of Q19 in the actual output stage. It also inverts the video signal with a gain of -10 and drives the base of Q30. Q30 thru Q32 each give a diode drop to the level of the video signal, similar to being connected as diodes. Being connected as

emitter-followers these transistors also give current gain to the signal. Q33 comes close to also giving a diode drop to the signal, the voltage drop across R27 being insignificant. R27 has been added to give some isolation between Q33 and the internal circuits of the LM1205/LM1207, adding to the stability of the device. Q33 also has R29 in its emitter for isolation from capacitive loads and current limiting from any possible voltage surges. R28 is at the collector of Q33 is also for current limiting from voltage surges and minimizing crosstalk between the three channels through the VCC line. To match the loading of the feedback section the output at pin 20 should have a load of 390Ω. To minimize power consumption the feedback section uses resistor values 10 times larger than those at pin 20. The current source at the emitter of Q33 provides for the capability to set the black level as low as 0.5V.

The video signal does go thru a number of diode drops at the output stage. One may be concerned that the tracking over temperature could be a problem. The feedback section has been designed to temperature track the output stage. The feedback for DC restoration eliminates the temperature coefficients of the diode junctions. The remaining section to be covered is the blanking section. This section comprises of Q25 thru Q29. Q26 thru Q28 are connected as diodes. Q25 provides current gain to this stage to adequately pull down the base of Q30 during blanking and also adding another diode potential. During blanking the base of Q30 will be four diode drops above ground, plus the saturation volt-

Circuit Description (Continued)

age of Q29. There are also four diode drops from the base of Q30 to the output, pin 20. Therefore during blanking pin 20 will be less than 100 mV above ground, enabling the designer to blank at the cathode of the CRT. R23 is added to quickly turn off Q25 by discharging its base when the blanking signal is removed.

Figure 14 also shows the power and ground pins to the LM1205/LM1207. All the V_{CC1} pins (pins 3, 11, 25) are all internally connected together. A 0.1 μF bypass capacitor must be located close to each pin and connected to ground. Further bypassing is done by a 100 μF capacitor. This capacitor needs to be located on the board close to the LM1205/LM1207. Pins 22 and 23 are the V_{CC2} pins. A 10 μF and a 0.1 μF bypass capacitors must be located close to pins 22 and 23. Correct bypassing of pins 22 and 23 is **very important**. If the bypassing is not adequate then the outputs of the LM1205/LM1207 will have ringing, or even worse they may oscillate. The ground side of the bypass capacitors at pins 22 and 23 must be returned to a ground plane with no interruptions from other traces between these capacitors and the ground pins 21 and 24 of the LM1205/LM1207.

Applications of the LM1205/LM1207

Figure 15 is the schematic of the demonstration board designed at National. Figure 16 is the actual layout of the demonstration board. Note that the schematic shown in

Figure 15 is almost identical to the schematic shown in Figure 4. The only difference between the two schematics is that in Figure 15 each channel has individual adjustments for both drive and cutoff, making this circuit a good design for monitor applications. Each CRT will have a slightly different cutoff voltage for each color, making it necessary to provide separate adjustments in order to accurately set the cutoff for each color. The gain of each color of the CRT is also slightly different; if the color temperature of the display is to be accurately set then each channel of the LM1205/LM1207 must have individual gain adjustments. Thus each channel has its own drive control. Once the drive control is set, the gain between the three color channels will closely track as the contrast is adjusted. All the jumpers needed to design a single sided PC board are shown in the schematic. The resistors and jumpers with no reference designation are the connections between the PC board and the connectors mounted on the PC board. CN1 thru CN8 are BNC connectors.

A 30Ω resistor is in series with each of the video inputs. A voltage surge may occur at these inputs when either the inputs are first connected to another system, or when the system is powered up before the monitor is turned on. If this voltage surge exceeds the supply voltage (at ground potential if the monitor is not powered up) of the LM1205/LM1207, or goes below ground, current will flow through the parasitic devices of the LM1205/LM1207. This current is limited by the 30Ω resistors, preventing a potential catastrophic failure. A 100Ω resistor is added to the Blank Gate

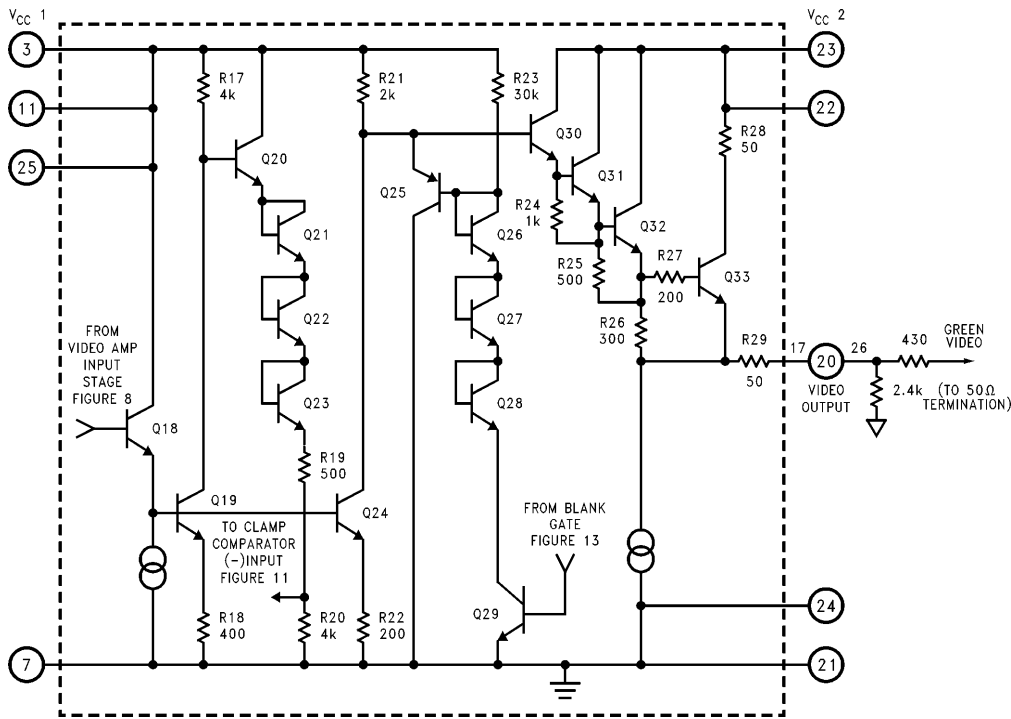

FIGURE 14. Simplified Schematic of LM1205/LM1207 Video Amplifier Output Stage with Blank Circuit

TL/H/11881-22

Applications of the LM1205/LM1207 (Continued)

and Clamp Gate inputs. These two resistors also limit the current during a voltage surge. A larger resistor is required because these inputs are DC coupled, allowing the current to continuously flow into these inputs before the monitor is turned on. 100Ω resistors are not recommended at the video inputs because this resistance value will start to roll off the frequency response of the LM1205/LM1207.

Note that the layout shown in *Figure 16* does have a very extensive ground plane. One must remember that the LM1205/LM1207 is a 130 MHz/85 MHz part and a single sided board is difficult to successfully design. A ground plane similar to the layout shown in *Figure 16* must be provided for good performance of the LM1205/LM1207 when using either a single sided or double sided board. The layout of this board demonstrates the importance of grounding. The results of this layout are shown in *Figures 17a* through *17d*. In these photographs the LM1205 rise time was 2.25 ns and its fall time was 3.00 ns. For the LM1207, the rise time was 4.10 ns and the fall time 3.85 ns. The output was a 4 V_{pp} signal and the cutoff voltage was set to 2V. The

overshoot will subsequently be filtered out by the loading effects of the CRT driver stage and the CRT itself. When the LM1205/LM1207 is designed into a video board one must keep the ground to the CRT driver stage separate from the ground of the LM1205/LM1207, connecting the two grounds together only at one point. National Semiconductor also manufactures a line of CRT drivers. Please contact National for additional information. These drivers greatly simplify the driver design allowing for shorter design cycles. Of course the LM1205/LM1207 can also be designed with a discrete driver stage. *Figure 18* shows a design using a simple cascode CRT driver. The LM1205/LM1207 block would be the same schematic as shown in *Figure 15*.

REFERENCES

- Zahid Rahim, "Guide to CRT Video Design," Application Note 861, National Semiconductor Corp., Jan. 1993
- Ott, Henry W. *Noise Reduction Techniques in Electronic Systems*, John Wiley & Sons, New York, 1976

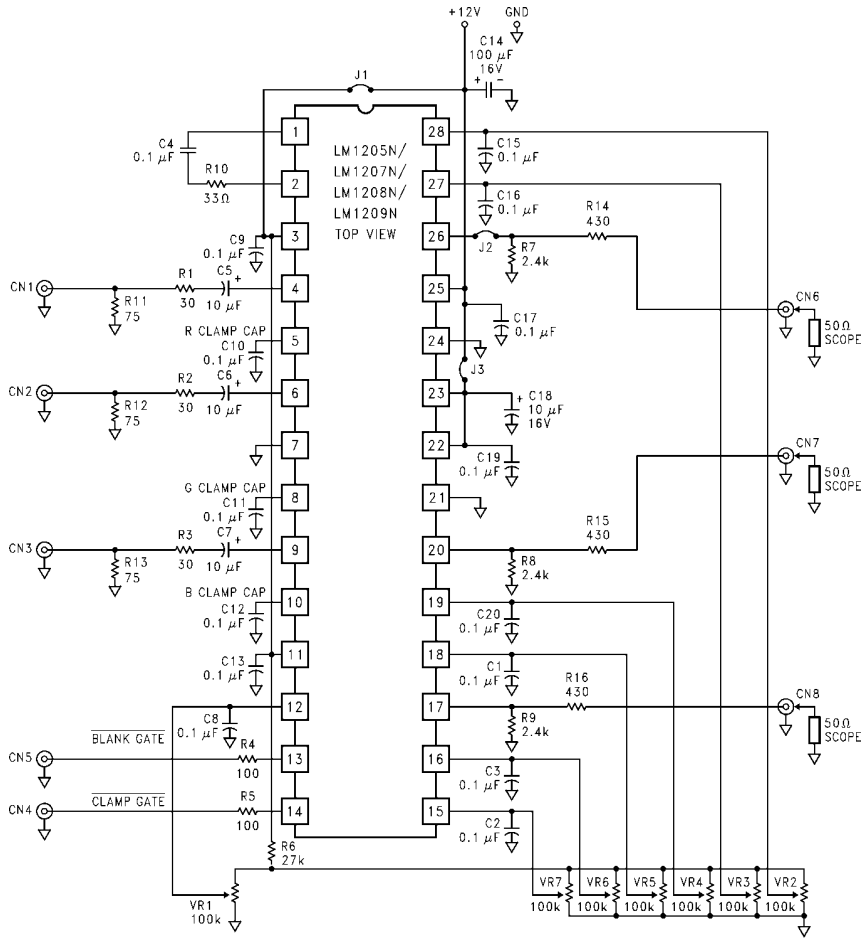
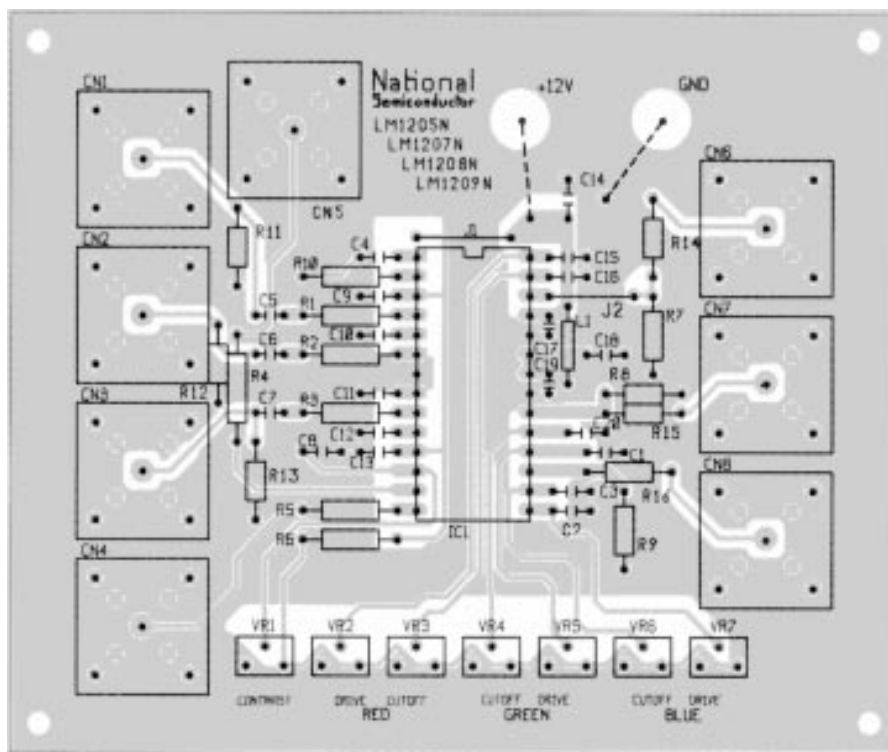

FIGURE 15. Demonstration Board Schematic

TL/H/11881-23

Applications of the LM1205/LM1207 (Continued)



TL/H/11881-24

FIGURE 16. Demonstration Board Layout

Applications of the LM1205/LM1207 (Continued)

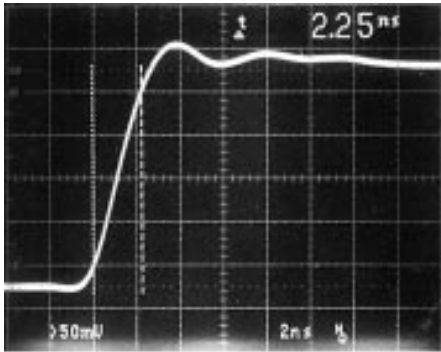

TL/H/11881-25

FIGURE 17a. LM1205 Rise Time

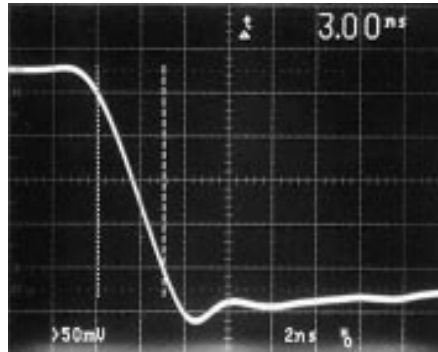

TL/H/11881-26

FIGURE 17b. LM1205 Fall Time

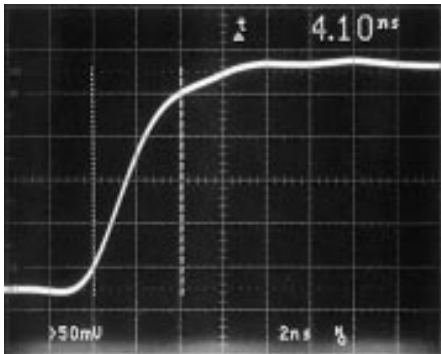

TL/H/11881-27

FIGURE 17c. LM1207 Rise Time

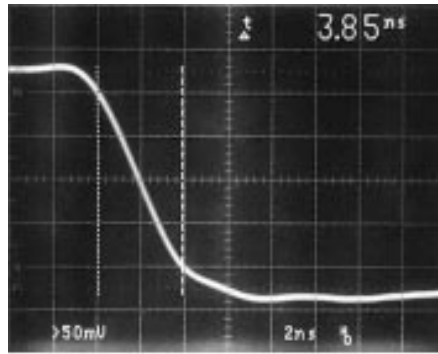

TL/H/11881-28

FIGURE 17d. LM1207 Fall Time

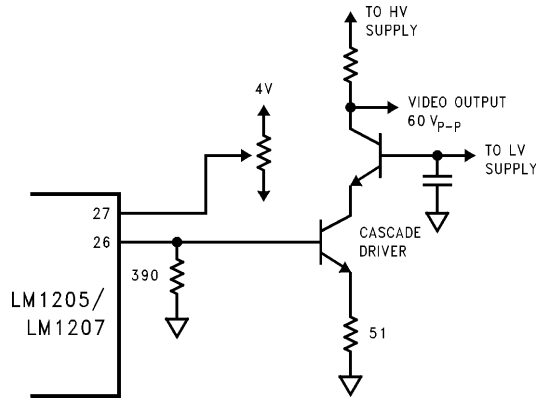

TL/H/11881-29

FIGURE 18. LM1205/LM1207 Typical Application

[查询"LM1205N"供应商](#)

