

**MEDIUM VOLTAGE NPN FAST-SWITCHING  
DARLINGTON TRANSISTOR**

- SGS-THOMSON PREFERRED SALESTYPE
- NPN DARLINGTON
- LOW BASE-DRIVE REQUIREMENTS
- FAST SWITCHING SPEED
- INTEGRATED ANTIPARALLEL COLLECTOR-EMITTER DIODE

**APPLICATIONS**

- HORIZONTAL DEFLECTION FOR MONOCHROME TVs
- GENERAL PURPOSE SWITCHING

**DESCRIPTION**

The BU810 is a Multiepitaxial Planar NPN Transistor in TO-220 package. It is intended for use in high frequency and efficiency converters, switching regulators and motor control.

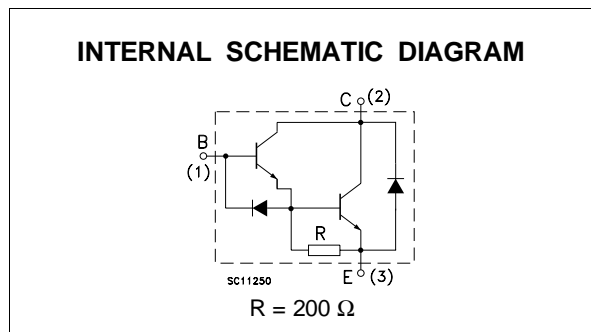
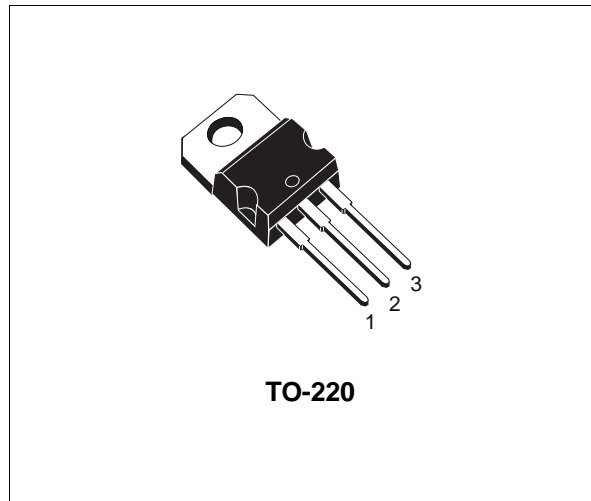

**ABSOLUTE MAXIMUM RATINGS**

Symbol	Parameter	Value	Unit
$V_{CBO}$	Collector-Base Voltage ( $I_E = 0$ )	600	V
$V_{CEO}$	Collector-Emitter Voltage ( $I_B = 0$ )	400	V
$V_{EBO}$	Emitter-Base Voltage ( $I_C = 0$ )	5	V
$I_C$	Collector Current	7	A
$I_{CM}$	Collector Peak Current	10	A
$I_B$	Base Current	2	A
$P_{tot}$	Total Power Dissipation at $T_{case} \leq 25 \text{ }^\circ\text{C}$	75	W
$T_{stg}$	Storage Temperature	-65 to 150	$^\circ\text{C}$
$T_j$	Junction Temperature	150	$^\circ\text{C}$

## THERMAL DATA

R <sub>thj-case</sub>	Thermal Resistance Junction-case	Max	1.66	°C/W
-----------------------	----------------------------------	-----	------	------

## ELECTRICAL CHARACTERISTICS (T<sub>case</sub> = 25 °C unless otherwise specified)

Symbol	Parameter	Test Conditions	Min.	Typ.	Max.	Unit
I <sub>CES</sub>	Collector Cut-off Current (V <sub>BE</sub> = 0)	V <sub>CE</sub> = 600 V			200	μA
I <sub>CEO</sub>	Collector Cut-off Current (I <sub>B</sub> = 0)	V <sub>CE</sub> = 400 V			1	mA
I <sub>EBO</sub> *	Emitter Cut-off Current (I <sub>C</sub> = 0)	V <sub>EB</sub> = 5 V			150	mA
V <sub>CEO(sus)</sub> *	Collector-Emitter Sustaining Voltage	I <sub>C</sub> = 0.1 A	400			V
V <sub>CE(sat)</sub> *	Collector-Emitter Saturation Voltage	I <sub>C</sub> = 2 A    I <sub>B</sub> = 20 mA			2	V
		I <sub>C</sub> = 4 A    I <sub>B</sub> = 200 mA			2.5	V
		I <sub>C</sub> = 7 A    I <sub>B</sub> = 0.7 A			3	V
V <sub>BE(sat)</sub> *	Base-Emitter Saturation Voltage	I <sub>C</sub> = 2 A    I <sub>B</sub> = 20 mA			2.2	V
		I <sub>C</sub> = 4 A    I <sub>B</sub> = 200 mA			3	V
V <sub>F</sub>	Diode Forward Voltage	I <sub>F</sub> = 7 A			3	V

## RESISTIVE SWITCHING TIMES

Symbol	Parameter	Test Conditions	Min.	Typ.	Max.	Unit
t <sub>on</sub>	Turn-on Time	V <sub>Clamp</sub> = 250V    I <sub>C</sub> = 2A    I <sub>B1</sub> = 20mA V <sub>BE(off)</sub> = -5 V			0.6	μs
t <sub>s</sub>	Storage Time				1.5	μs
t <sub>f</sub>	Fall Time				0.5	μs

## INDUCTIVE SWITCHING TIMES

Symbol	Parameter	Test Conditions	Min.	Typ.	Max.	Unit
t <sub>s</sub>	Storage Time	V <sub>Clamp</sub> = 250V    I <sub>C</sub> = 2A    I <sub>B1</sub> = 20mA V <sub>BE(off)</sub> = -5 V    L = 500μH			1.5	μs
t <sub>f</sub>	Fall Time				0.4	μs
t <sub>s</sub>	Storage Time	V <sub>Clamp</sub> = 250V    I <sub>C</sub> = 7A    I <sub>B1</sub> = 0.7A V <sub>BE(off)</sub> = -5 V    L = 500μH			1.5	μs
t <sub>f</sub>	Fall Time				0.4	μs

\* Pulsed : Pulse duration = 300 μs, duty cycle = 2%

**TO-220 MECHANICAL DATA**

DIM.	mm			inch		
	MIN.	TYP.	MAX.	MIN.	TYP.	MAX.
A	4.40		4.60	0.173		0.181
C	1.23		1.32	0.048		0.051
D	2.40		2.72	0.094		0.107
D1		1.27			0.050	
E	0.49		0.70	0.019		0.027
F	0.61		0.88	0.024		0.034
F1	1.14		1.70	0.044		0.067
F2	1.14		1.70	0.044		0.067
G	4.95		5.15	0.194		0.203
G1	2.4		2.7	0.094		0.106
H2	10.0		10.40	0.393		0.409
L2		16.4			0.645	
L4	13.0		14.0	0.511		0.551
L5	2.65		2.95	0.104		0.116
L6	15.25		15.75	0.600		0.620
L7	6.2		6.6	0.244		0.260
L9	3.5		3.93	0.137		0.154
DIA.	3.75		3.85	0.147		0.151

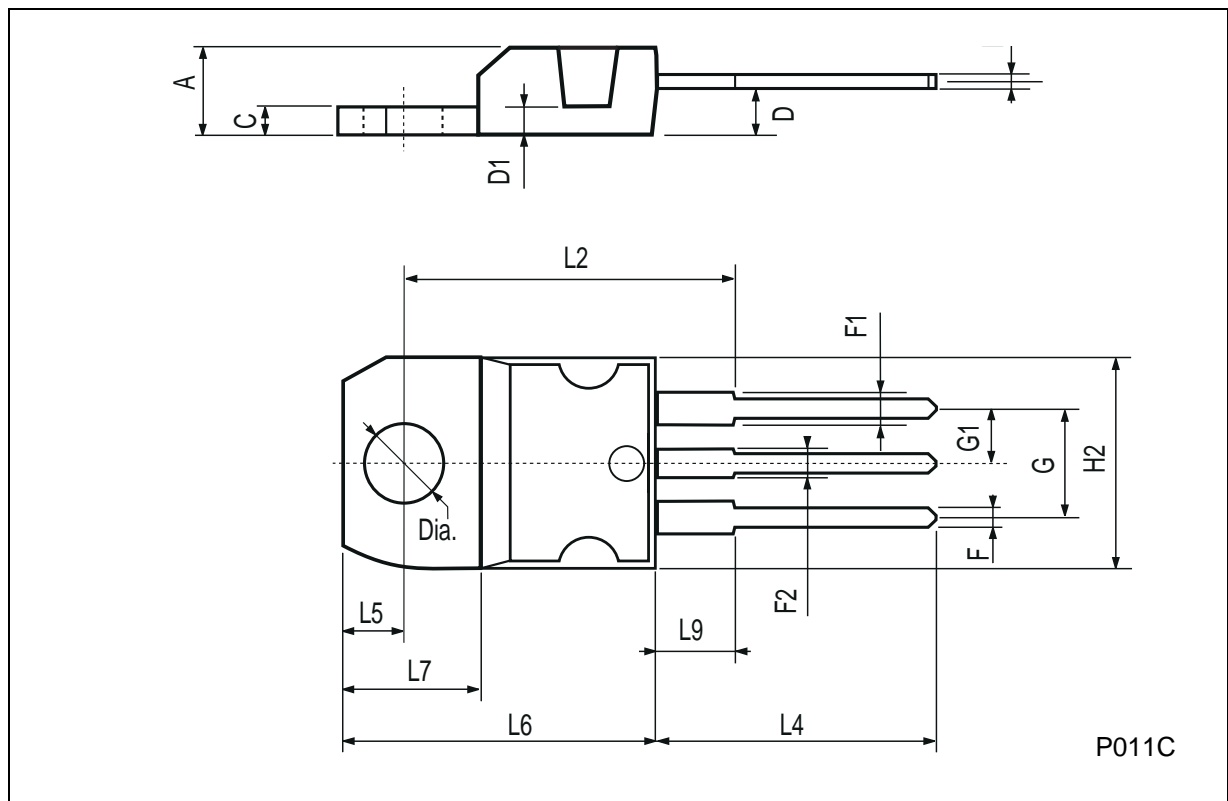

Information furnished is believed to be accurate and reliable. However, SGS-THOMSON Microelectronics assumes no responsibility for the consequences of use of such information nor for any infringement of patents or other rights of third parties which may result from its use. No license is granted by implication or otherwise under any patent or patent rights of SGS-THOMSON Microelectronics. Specifications mentioned in this publication are subject to change without notice. This publication supersedes and replaces all information previously supplied. SGS-THOMSON Microelectronics products are not authorized for use as critical components in life support devices or systems without express written approval of SGS-THOMSON Microelectronics.

© 1997 SGS-THOMSON Microelectronics - Printed in Italy - All Rights Reserved

SGS-THOMSON Microelectronics GROUP OF COMPANIES  
Australia - Brazil - Canada - China - France - Germany - Hong Kong - Italy - Japan - Korea - Malaysia - Malta - Morocco - The Netherlands -  
Singapore - Spain - Sweden - Switzerland - Taiwan - Thailand - United Kingdom - U.S.A  
...