

GERMANIUM POWER TRANSISTORS

Type Number	Case Type	V_{CE0} V	V_{EBO} V	V_{CER} V	V_{CES} V	CURRENT GAIN				SATURATION VOLTAGES				θ_{j-c} °C/W
						h_{FE} Min.	h_{FE} Max.	$V_{CE} @ I_C$ V	$I_C @ I_B$ A	$V_{CE(s)}$ V	$V_{BE(s)}$ V	$I_C @ I_B$ A	$I_C @ I_B$ A	

10 AMP GERMANIUM PNP (Cont.)

2N629	TO-3	80		40.0		60	10	30	2.0	10.0	1.00		10.0	1.000	.80
2N630	TO-3	100		50.0		75	10	30	2.0	10.0	1.00		10.0	1.000	.80
2N1073	TO-3	40		.8	40		20	60	2.0	5.0	1.00		5.0	.500	1.20
2N1073A	TO-3	80		.8	80		20	60	2.0	5.0	1.00		5.0	.500	1.20
2N1073B	TO-3	120		.8	120		20	60	2.0	5.0	1.00		5.0	.500	1.20
2N1430	TO-41*	120	100	1.0			30	120	2.0	5.0	.40	.90	10.0	1.000	1.20
2N2212	TO-41*	120	60	1.5	120		50	120	2.0	5.0	1.00	1.00	5.0	.500	.80
2N2288	TO-3	40	30	.8	40		20	60	2.0	5.0	1.00	1.00	5.0	.500	1.20
2N2289	TO-3	80	50	.8	80		20	60	2.0	5.0	1.00	1.00	5.0	.500	1.20
2N2290	TO-3	120	70	.8	120		20	60	2.0	5.0	1.00	1.00	5.0	.500	1.20
2N2291	TO-3	40	30	.8	40		50	120	2.0	5.0	1.00	1.00	5.0	.500	1.20
2N2292	TO-3	80	50	.8	80		50	120	2.0	5.0	1.00	1.00	5.0	.500	1.20
2N2293	TO-3	120	70	.8	120		50	120	2.0	5.0	1.00	1.00	5.0	.500	1.20
2N2294	TO-41*	40		.8	40		50	120	2.0	5.0	1.00	1.00	5.0	.500	1.20
2N2295	TO-41*	80		.8	80		50	120	2.0	5.0	1.00	1.00	5.0	.500	1.20
2N2296	TO-41*	120		.8	120		50	120	2.0	5.0	1.00	1.00	5.0	.500	1.20
2N2444	TO-3	80	80	1.0			75	120	2.0	3.0	1.00	1.50	5.0	.500	1.00
2N2869	TO-3	60	50	10.0			50	165	2.0	1.0	.75		5.0	.500	1.50
2N2870	TO-3	80	50	10.0			50	165	2.0	1.0	.50		5.0	.500	1.50
2N5156	TO-3	100	60	60.0			25	60	2.0	5.0	1.00	1.80	10.0	1.000	.80

*TO-3 with solder lugs

12 AMP GERMANIUM PNP

2N173	TO-36	60	50	40.0		50	35	70	2.0	5.0	.30		12.0	2.000	1.00
2N174A	TO-36	80	55	60.0		70	25	70	2.0	5.0	.90		12.0	2.000	.80
2N441	TO-36	40	40	20.0		40	20	40	2.0	5.0	.30		12.0	2.000	1.00
2N442	TO-36	50	45	30.0		45	20	40	2.0	5.0	.30		12.0	2.000	1.00
2N443	TO-36	60	55			50	20	40	2.0	5.0	.30		12.0	2.000	1.00

15 AMP GERMANIUM PNP

2N278	TO-36	50	45	30.0		45	35	70	2.0	5.0	.30		12.0	2.000	1.00
2N677	TO-3	50	20	25.0		30	20	60	2.0	10.0	1.00		10.0	1.000	.80
2N677A	TO-3	60	30	25.0		40	20	60	2.0	10.0	1.00		10.0	1.000	.80
2N677B	TO-3	90	60	25.0		70	20	60	2.0	10.0	1.00		10.0	1.000	.80
2N677C	TO-3	100	70	25.0		80	20	60	2.0	10.0	1.00		10.0	1.000	.80
2N678	TO-3	50	20	25.0		30	50	100	2.0	10.0	1.00		10.0	1.000	.80
2N678A	TO-3	60	30	25.0		40	50	100	2.0	10.0	1.00		10.0	1.000	.80
2N678B	TO-3	90	60	25.0		70	50	100	2.0	10.0	1.00		10.0	1.000	.80
2N678C	TO-3	100	70	25.0		80	50	100	2.0	10.0	1.00		10.0	1.000	.80
2N1031	TO-3	50		10.0		30	20	60	2.0	10.0	1.00		10.0	1.000	.80
2N1031A	TO-3	60		15.0		40	20	60	2.0	10.0	1.00		10.0	1.000	.80
2N1031B	TO-3	90		15.0		70	20	60	2.0	10.0	1.00		10.0	1.000	.80
2N1031C	TO-3	100		15.0		80	20	60	2.0	10.0	1.00		10.0	1.000	.80
2N1032	TO-3	50		10.0		30	50	100	2.0	10.0	1.00		10.0	1.000	.80
2N1032A	TO-3	60		15.0		40	50	100	2.0	10.0	1.00		10.0	1.000	.80
2N1032B	TO-3	90		15.0		70	50	100	2.0	10.0	1.00		10.0	1.000	.80
2N1032C	TO-3	100		15.0		80	50	100	2.0	10.0	1.00		10.0	1.000	.80
2N1099	TO-36	80	55	40.0		70	35	70	2.0	5.0	.30		12.0	2.000	.80
2N1100	TO-36	100	65	80.0		80	25	50	2.0	5.0	.30		12.0	2.000	.80
2N1120	TO-3	80		40.0		70	20	50	2.0	10.0	1.00		10.0	1.000	1.50
2N1146	TO-3	40		30.0		30	60	150	2.0	5.0	1.00		15.0	1.000	.80
2N1146A	TO-3	60		30.0		40	60	150	2.0	5.0	1.00		4.0	.200	2.50
2N1146B	TO-3	80		30.0		60	60	150	2.0	5.0	1.00		10.0	1.000	2.50
2N1146C	TO-3	100		30.0		75	60	150	2.0	5.0	1.00		15.0	1.000	.80
2N1147	TO-3	40		30.0		30	60	150	2.0	5.0	1.00		15.0	1.000	.80
2N1147A	TO-3	60		30.0		40	60	150	2.0	5.0	1.00		15.0	1.000	.80
2N1147B	TO-3	80		30.0		60	60	150	2.0	5.0	1.00		15.0	1.000	.80
2N1147C	TO-3	100		30.0		75	60	150	2.0	5.0	1.00		15.0	1.000	.80
2N1358	TO-36	80	40	60.0		70	25	50	2.0	5.0	.30		12.0	2.000	.80
2N1412	TO-36	100	65	60.0		80	25	50	2.0	5.0	.70		12.0	2.000	.80
2N1412A															
2N1549	TO-3	40		20.0		30	10	30	2.0	10.0	1.00		10.0	1.000	.80
2N1549A	TO-3	40		20.0		30	10	30	2.0	10.0	1.00		10.0	1.000	.80
2N1550	TO-3	60		30.0		45	10	30	2.0	10.0	1.00		10.0	1.000	.80
2N1550A	TO-3	60		30.0		45	10	30	2.0	10.0	1.00		10.0	1.000	.80
2N1551	TO-3	80		40.0		60	10	30	2.0	10.0	1.00		10.0	1.000	.80
2N1551A	TO-3	80		40.0		60	10	30	2.0	10.0	1.00		10.0	1.000	.80
2N1552	TO-3	100		50.0		75	10	30	2.0	10.0	1.00		10.0	1.000	.80
2N1552A	TO-3	100		50.0		75	10	30	2.0	10.0	1.00		10.0	1.000	.80
2N1553	TO-3	40	20	20.0		30	30	60	2.0	10.0	.50		10.0	1.000	.80

GERMANIUM POWER TRANSISTORS

查询"2N1031C"供应商

CASE OUTLINE DRAWINGS & DIMENSIONS

TO-5

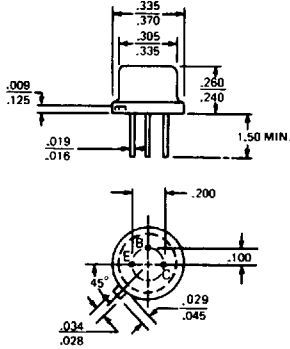

TO-8

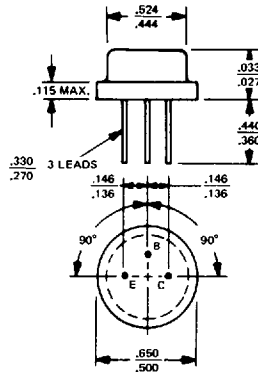

TO-37

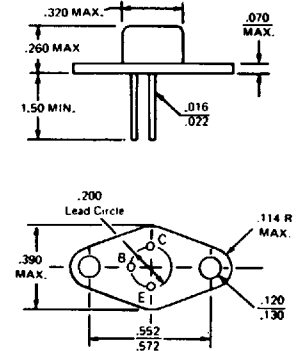

MT-27

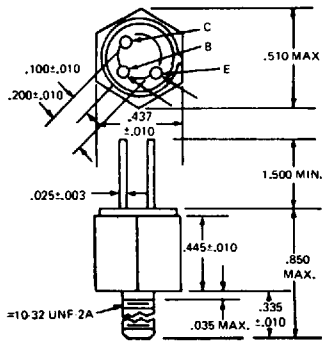

MT-28

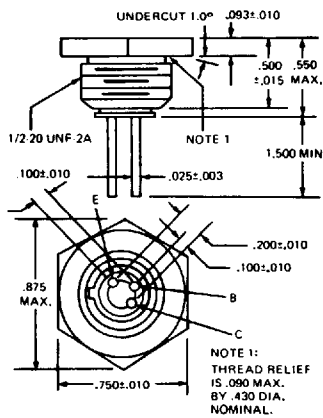

TO-3

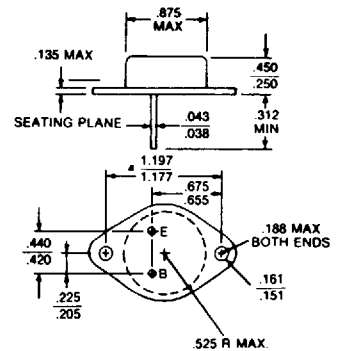

MODIFIED TO-3
(60 mil pins)

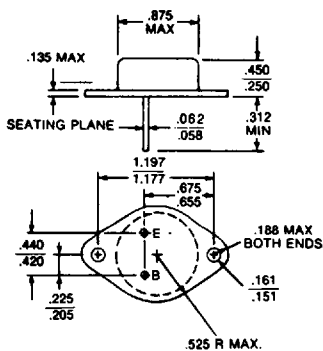

TO-41

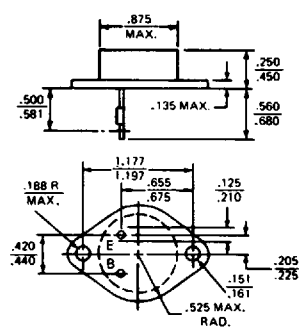

TO-36

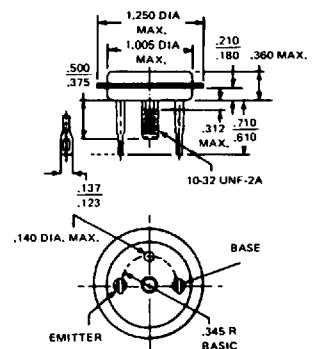

GERMANIUM POWER TRANSISTORS

查询"2N1031C"供应商

CASE OUTLINE DRAWINGS & DIMENSIONS

TO-13

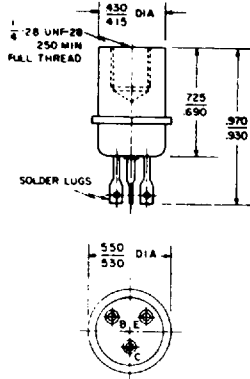

TO-66

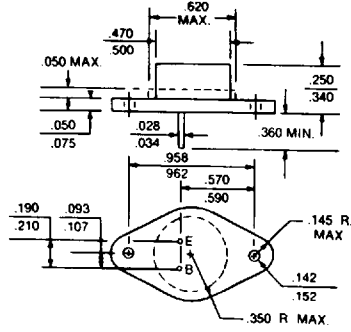

MS-7

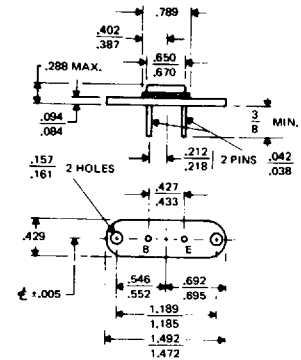

MT-22

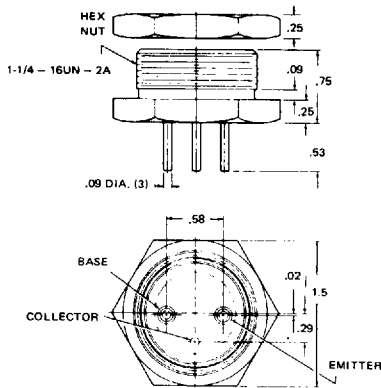

MT-23

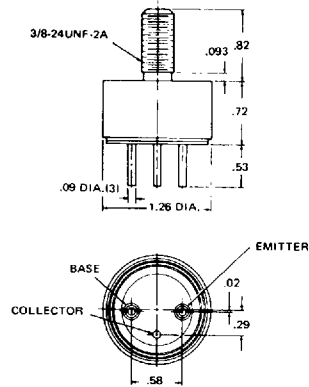

MT-7

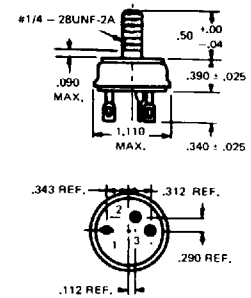

TO-68

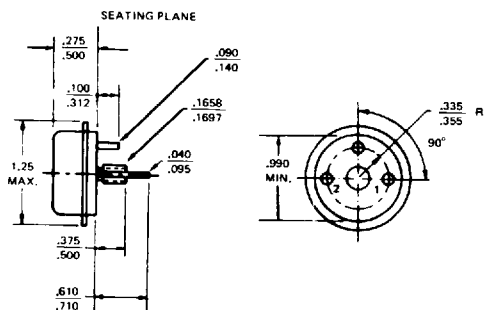

MT-36

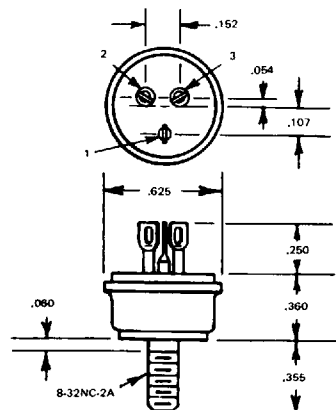

GERMANIUM POWER TRANSISTORS

查询"2N1031C"供应商

CASE OUTLINE DRAWINGS & DIMENSIONS

NS257

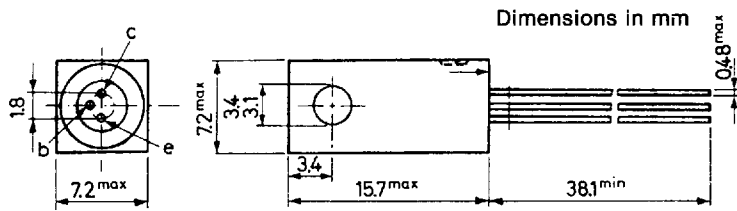

TO-1

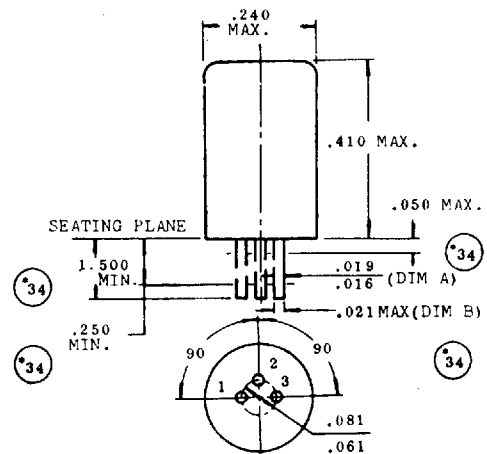

TO-18

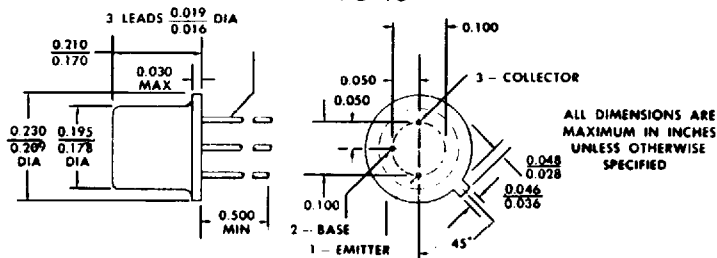

THE COLLECTOR IS ELECTRICAL CONTACT WITH THE CASE.

ALL JEDEC TO-18 DIMENSIONS AND NOTES ARE APPLICABLE.



GERMANIUM POWER DEVICES CORP.

300 Brickstone Square · York Street · P.O. Box 3065
Shawsheen Village Station · Andover, Massachusetts 01810
Telephone (508) 475-5982 · FAX (508) 470-1512

26

Printed in U.S.A.

■ 3947375 0000689 52T ■

54134