

Battery Disconnect Switch

FEATURES

- Solution for Bi-Directional Blocking Bi-Directional Conduction Switch
- 6- to 30-V Operation
- Ground Referenced Logic Level Inputs
- Integrated Low $r_{DS(on)}$ MOSFET
- Level-Shifted Gate Drive with Internal MOSFET
- Ultra Low Power Consumption in Off State (Leakage Current Only)
- Logic Supply Voltage is Not Required

DESCRIPTION

The Si4710CY is a level-shifted p-channel MOSFET. Operating two in a series, these MOSFETs can be used as a reverse blocking switch for battery disconnect applications. It is a solution for multiple battery technology designs or designs that require

isolation from the power bus during charging.

The Si4710CY is available in a 8-pin SOIC package and is rated for the commercial temperature range of -25 to 85°C .

FUNCTIONAL BLOCK DIAGRAM AND PIN CONFIGURATION

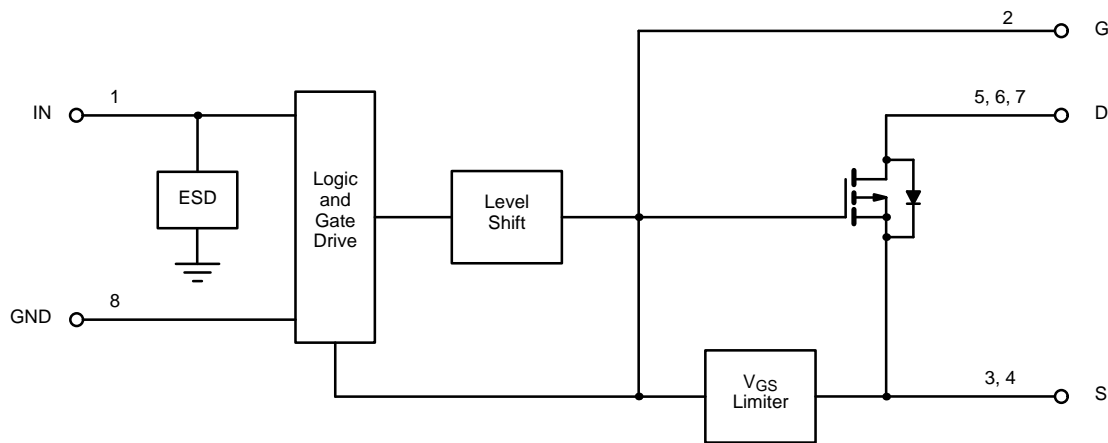

Half a circuit shown here.



ABSOLUTE MAXIMUM RATINGS

Voltage Referenced to GND		(t = steady state) 1.4 W
V_S, V_D^a	-0.3 V to 30 V	Thermal Resistance
V_{SD}	-0.3 V to 30 V	Max Junction-Ambient ^b (t = 10 sec) 55 C/W
V_{IN1}, V_{IN2}	-0.3 V to 15 V	(t = steady state) 90 C/W
V_{GS}	20 V	Max Junction-Foot (t = steady state) 27 C/W
Storage Temperature	-55 to 150°C	Notes
Power Dissipation ^b (t = 10 sec)	2.3 W	a. $V_{SD} \leq 30 V_{DC}$
		b. Device mounted with all leads soldered to 1" x 1" FR4 with laminated copper PC board.

Stresses beyond those listed under "Absolute Maximum Ratings" may cause permanent damage to the device. These are stress ratings only, and functional operation of the device at these or any other conditions beyond those indicated in the operational sections of the specifications is not implied. Exposure to absolute maximum rating conditions for extended periods may affect device reliability.

RECOMMENDED OPERATING RANGE

V_S, V_D	6 V to 30 V	Operating Temperature Range	-25 to 85°C
V_{IN1}, V_{IN2}	0 V to 13.2 V	Junction Temperature	-25 to 150°C
I_{DS}	0 A to 6 A		

SPECIFICATIONS									
Parameter	Symbol	Specific Test Conditions	Limits				Unit		
			Temp ^a	Min ^b	Typ ^c	Max ^b			
On-Resistance	r_{DS}	$V_S = 10 V, I_D = 1 A, V_{IN} = H$	Room		0.014	0.018	Ω		
Leakage Current	$I_{DS(off)}$	$V_{DS} = 10 V$	Room			1	μA		
Power Consumption	I_S GND(off)	$V_S = 17 V$	Room			1			
	I_S GND(on)		Room		1.1	6			
Input Voltage Low	V_{INL}	$V_S = 10 V$	Full			0.8	V		
Input Voltage High	V_{INH}		Full	2.5					
Input Leakage Current	I_{INH}	$V_{IN} = 5.0 V$	Full			5	μA		
Turn-On Delay	IN to D or S	$V_S = 10 V, R_L = 5 \Omega, \text{Test Circuit 1}$	$t_{ON(IN)}$	Room		3.0	6	μs	
Turn-Off Delay			$t_{OFF(IN)}$	Room		1.5	3		
Rise Time			t_{RISE}	Room		1.25	3		
Fall Time			t_{FALL}	Room		50	150		ns
Voltage Across Pin 6 and 7			V_{GS}	$V_S = 30 V$	Room		10.2		18
Forward Diode	V_{SD}	$I_D = -1 A$	Room			1.1			

- Notes
- Room = 25°C, Full = as determined by the operating temperature suffix.
 - The algebraic convention whereby the most negative value is a minimum and the most positive a maximum.
 - Typical values are for DESIGN AID ONLY, not guaranteed nor subject to production testing.

TIMING DIAGRAMS

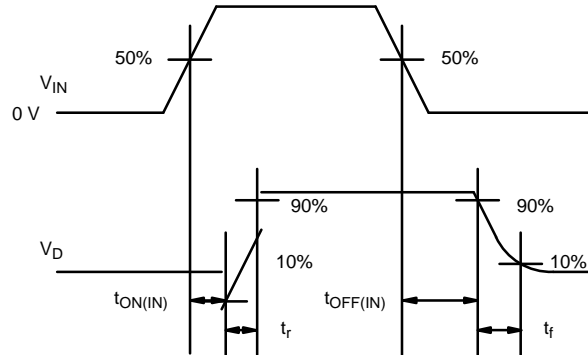
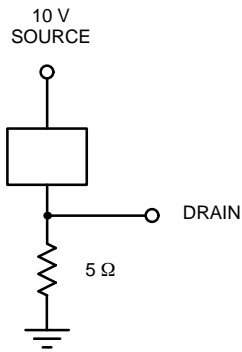

TEST CIRCUIT 1

PIN CONFIGURATION

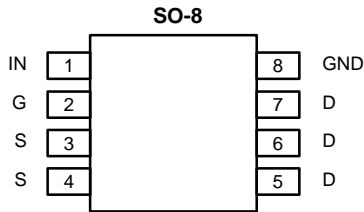

Order Number: Si4710CY

TRUTH TABLE	
V_{IN}	Switch
0	Off
0	Off
1	On
1	On

PIN DESCRIPTION		
Pin Number	Symbol	Description
5, 6	D	Drain connection for MOSFET.
8	GND	Ground
1	IN	Logic input, IN. High level turns on the switch.
2	G	Gate output to MOSFET.
3, 4	S	Source connection for MOSFET.

TYPICAL CHARACTERISTICS (25°C UNLESS NOTED)

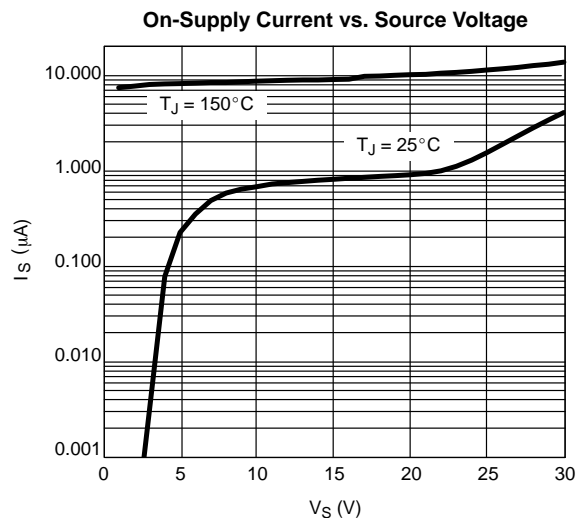
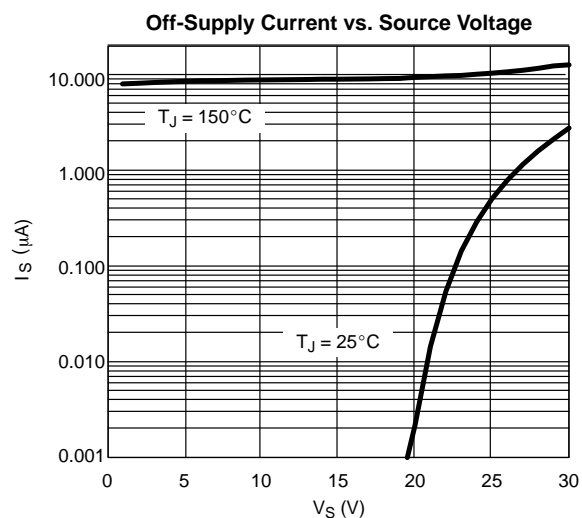
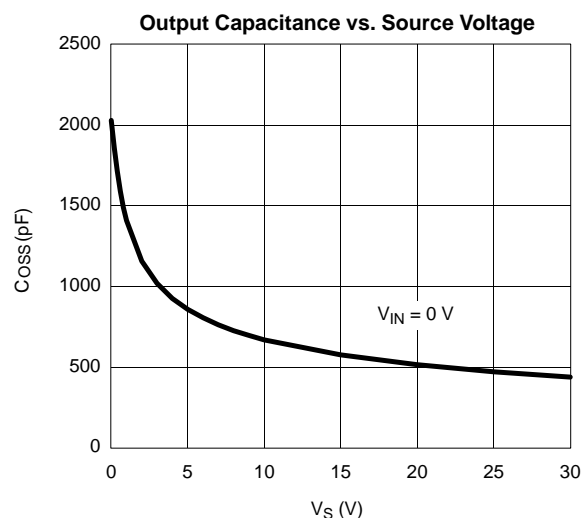
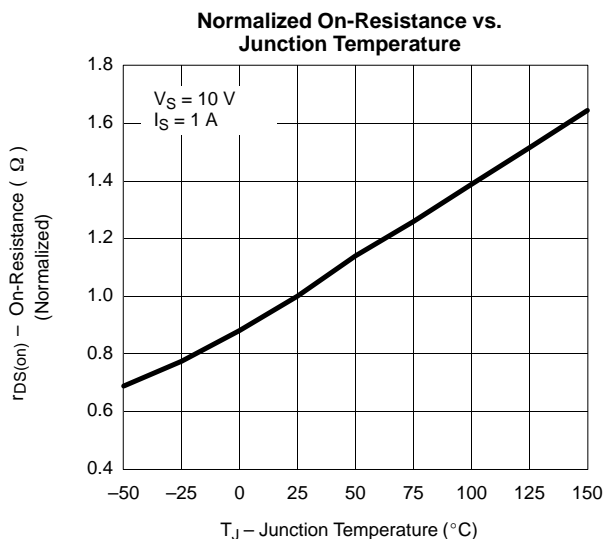
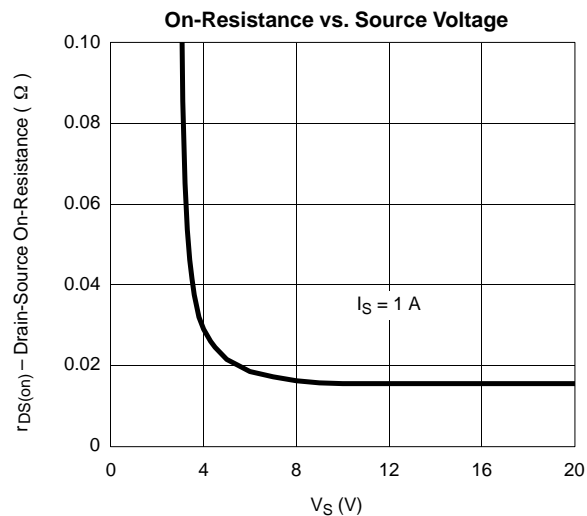
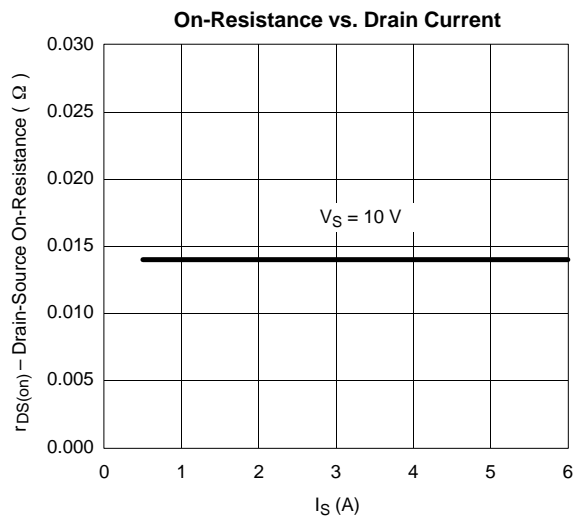



TYPICAL CHARACTERISTICS (25°C UNLESS NOTED)

Drain-Source Diode Forward Voltage

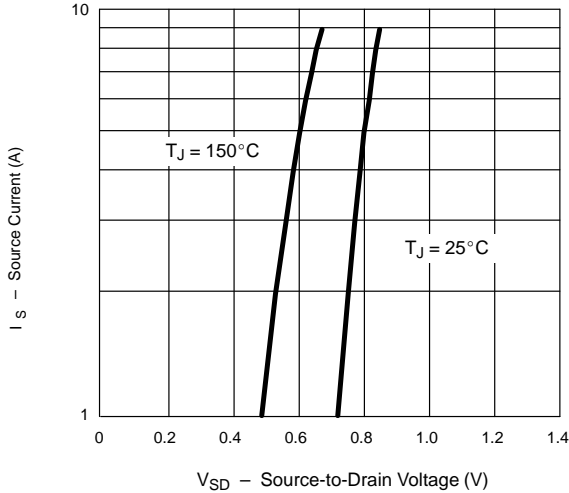

Input Voltage Trip Point vs. Temperature

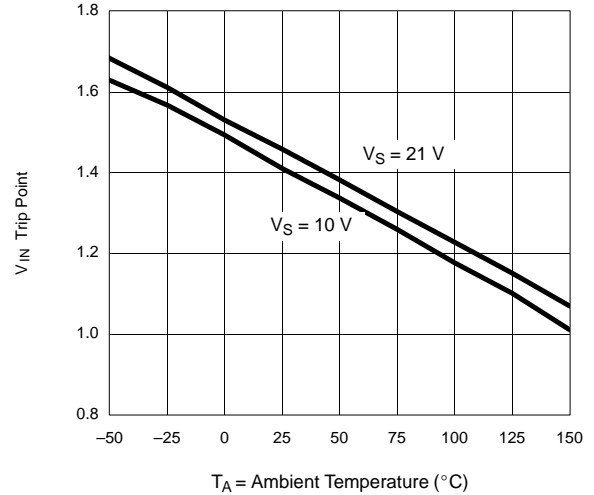

Turn-On Delay vs. Temperature

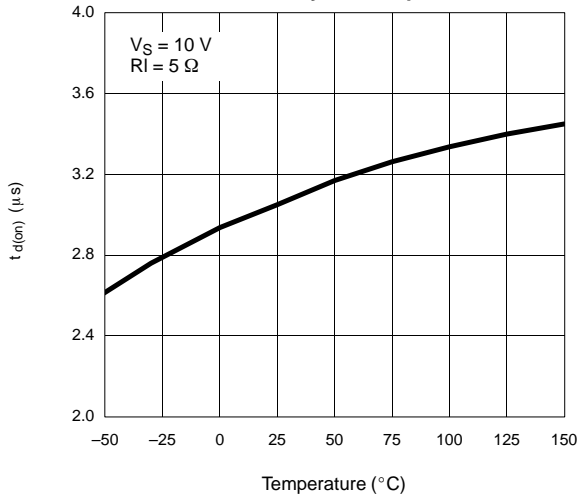

Turn-off Delay vs. Temperature

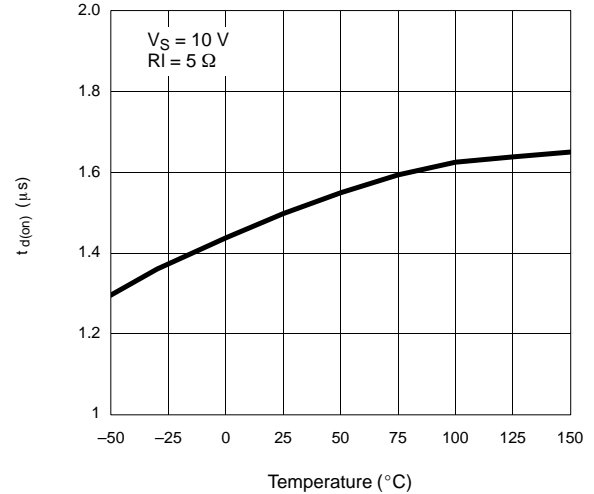

Rise Time vs. Temperature

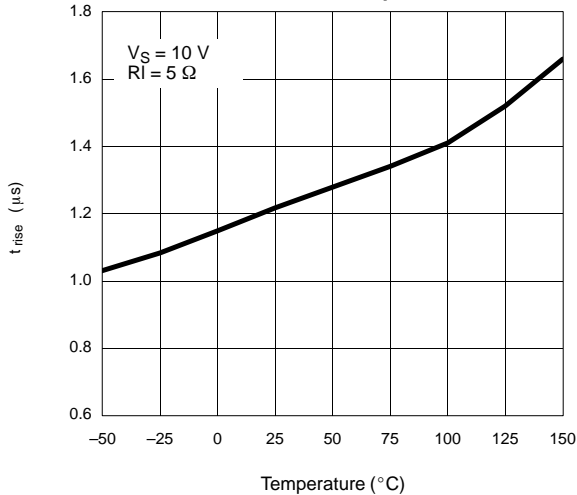

Fall Time vs. Temperature

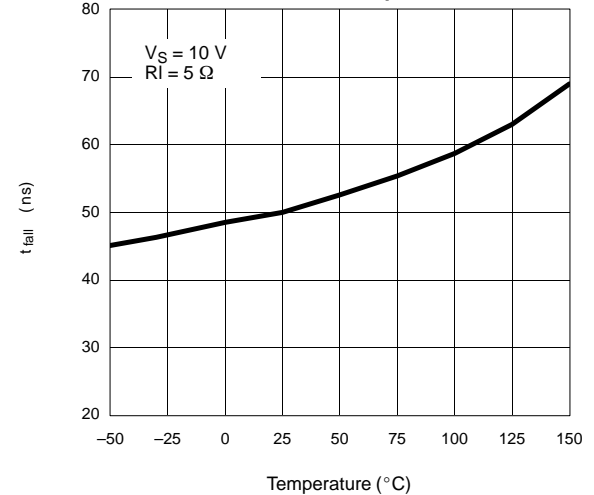

TYPICAL CHARACTERISTICS (25°C UNLESS NOTED)

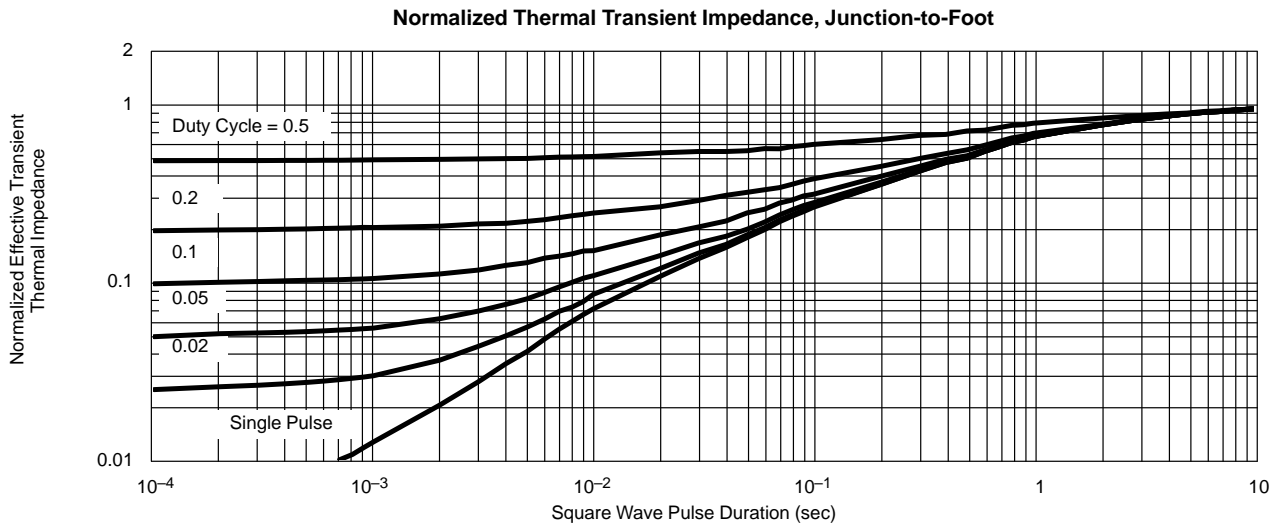
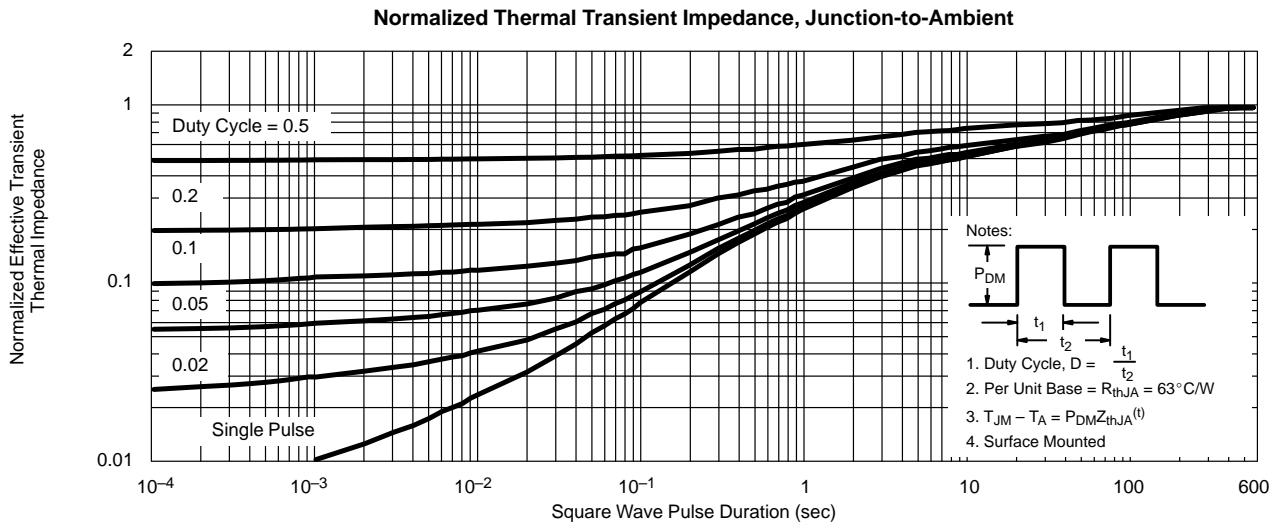
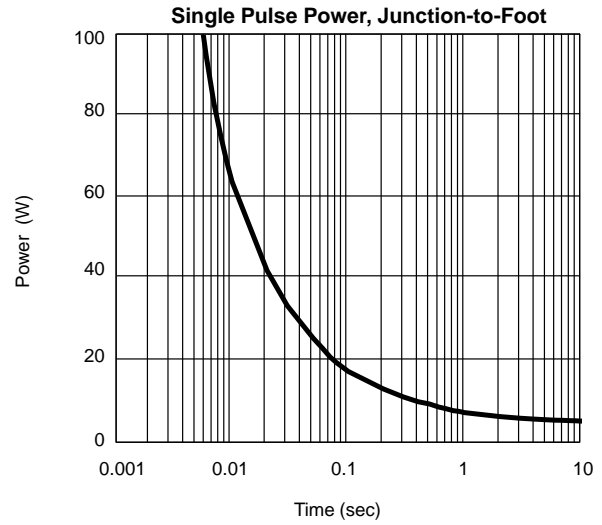
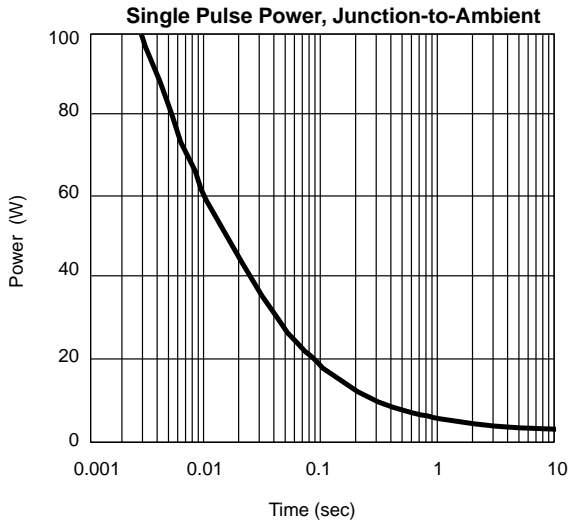

APPLICATION DRAWINGS

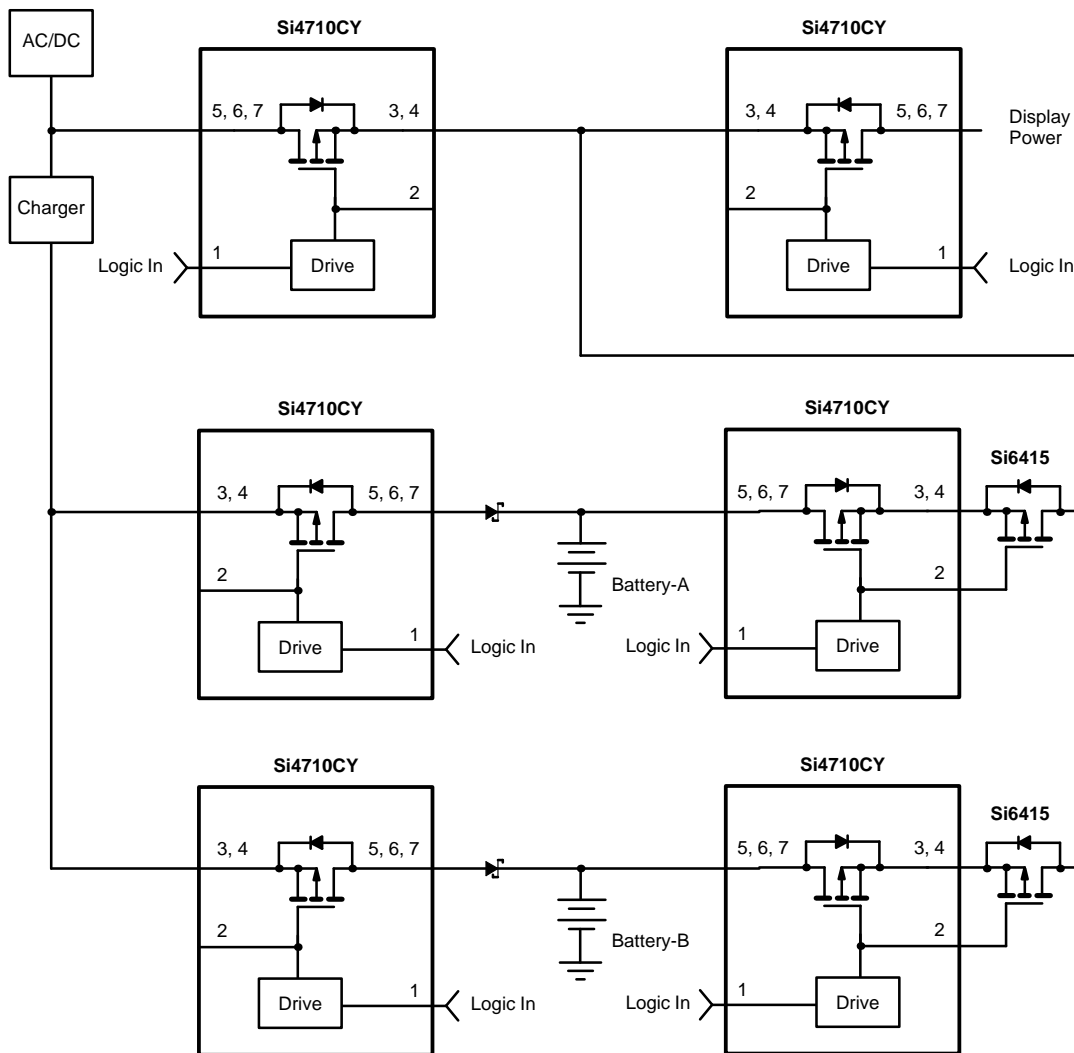

Figure 1: High-Performance Laptop PC

APPLICATION DRAWINGS

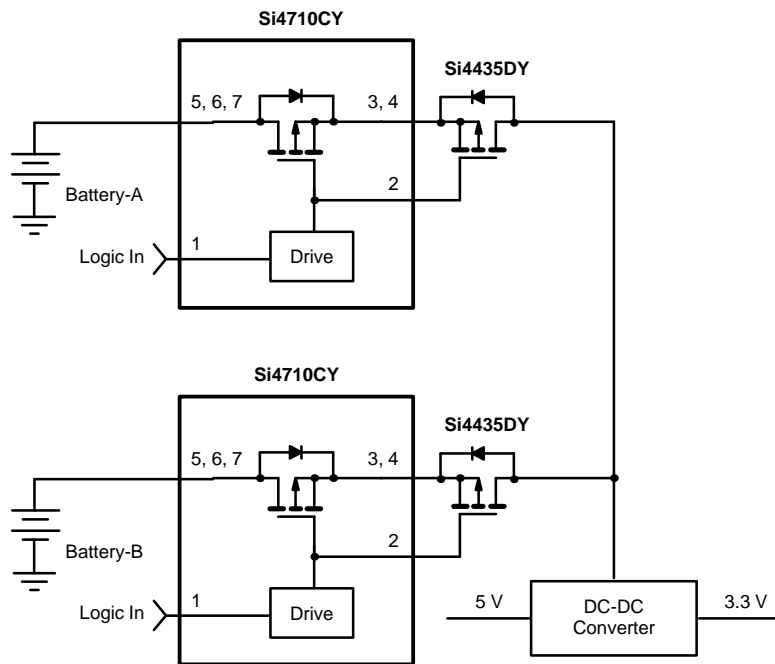

Figure 2:

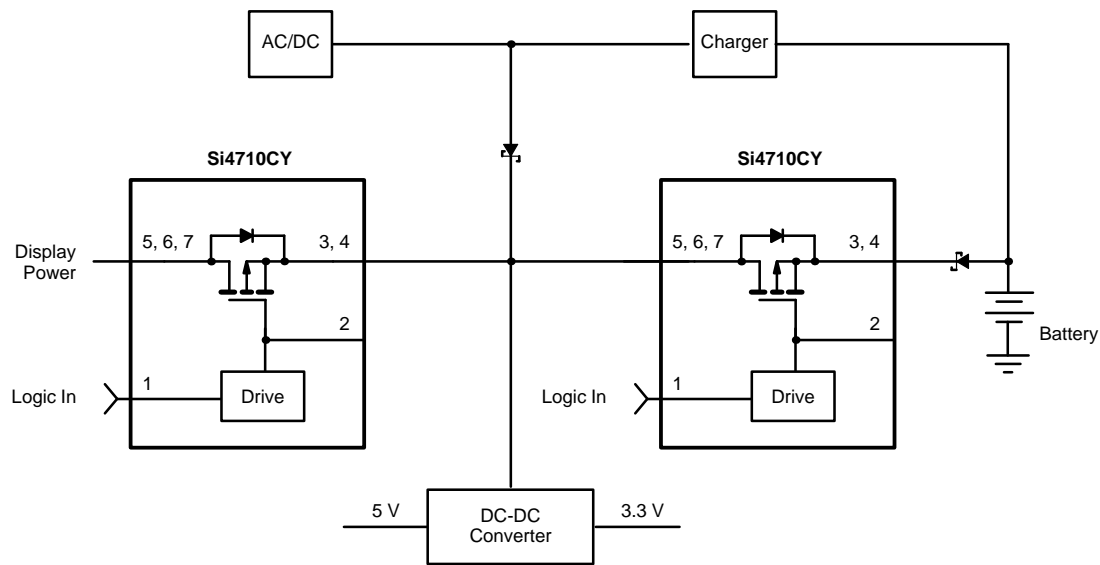

Figure 3: Low-Cost Laptop PC

APPLICATION DRAWINGS

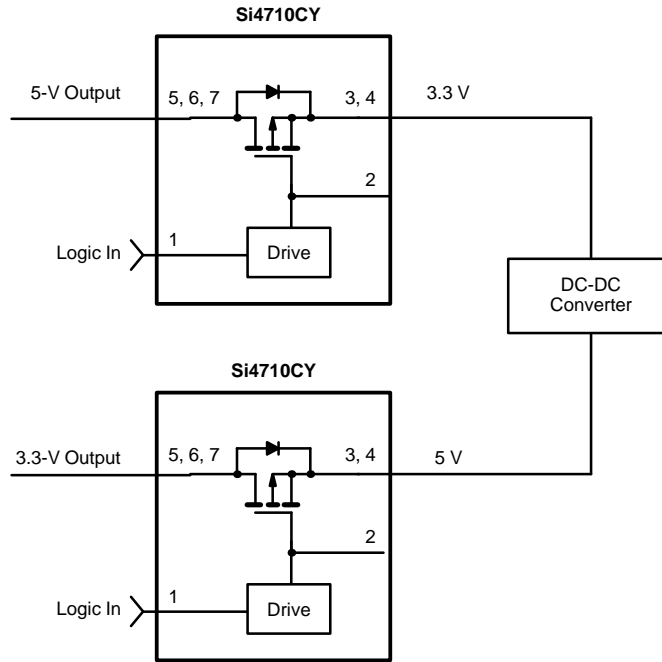

Figure 4: ACPI Power Saving Switcher