

GENERAL DESCRIPTION

The EV2355DN-00A is the Evaluation Board for MPS' MP2355 Step-Down DC/DC Converter. It features a wide supply range of 4.75V to 23V and a continuous output current up to 3A. The output voltage is set to 3.3V, but can be easily adjusted to other levels from 1.22V. A 380KHz high switching frequency allows the use of small, low cost capacitors and inductors. Current mode control and an integrated power MOSFET minimize component count, board area, and solution cost. Fault condition protection includes cycle-by-cycle current limiting, thermal shutdown, and under-voltage lockout. Internal soft-start reduces the turn-on stress. The small 8-pin SOIC package with exposed pad minimizes board area and provides excellent thermal management.

ELECTRICAL SPECIFICATION

Parameter	Symbol	Value	Units
Supply Voltage	V _{IN}	4.75 to 23	V
Output Voltage	V _{OUT}	3.3	V
Output Current	I _{OUT}	0 to 3	A

FEATURES

- Up to 3A Continuous Output Current
- Wide 4.75V to 23V Operating Input Range
- Monolithic Buck with 100mΩ Internal FET
- Fixed 380KHz Frequency
- All Ceramic Input and Output Capacitors
- Programmable Soft-Start
- Programmable Input Under-Voltage Lockout

APPLICATIONS

- Distributed Power Systems
- Battery Chargers
- Pre-Regulator for Linear Regulators

"MPS" and "Monolithic Power Systems", are Registered Trademarks of Monolithic Power Systems, Inc.

EV2355DN-00A EVALUATION BOARD

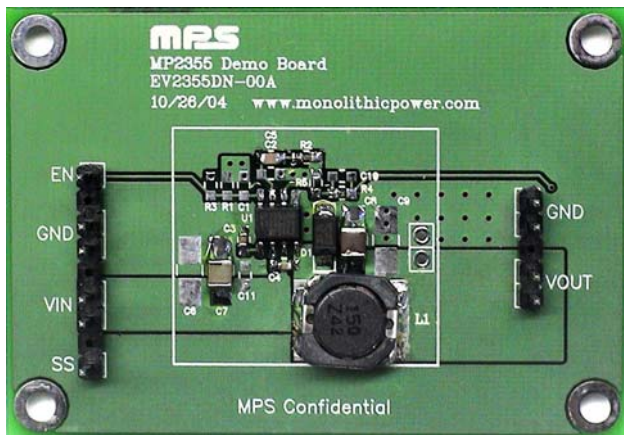

Dimensions (2.6"X x 1.9"Y x 0.4"Z)

Board Number	MPS IC Number
EV2355DN-00A	MP2355

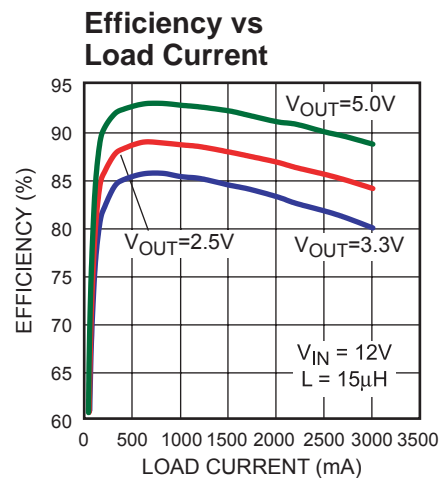

MP2355_EC01

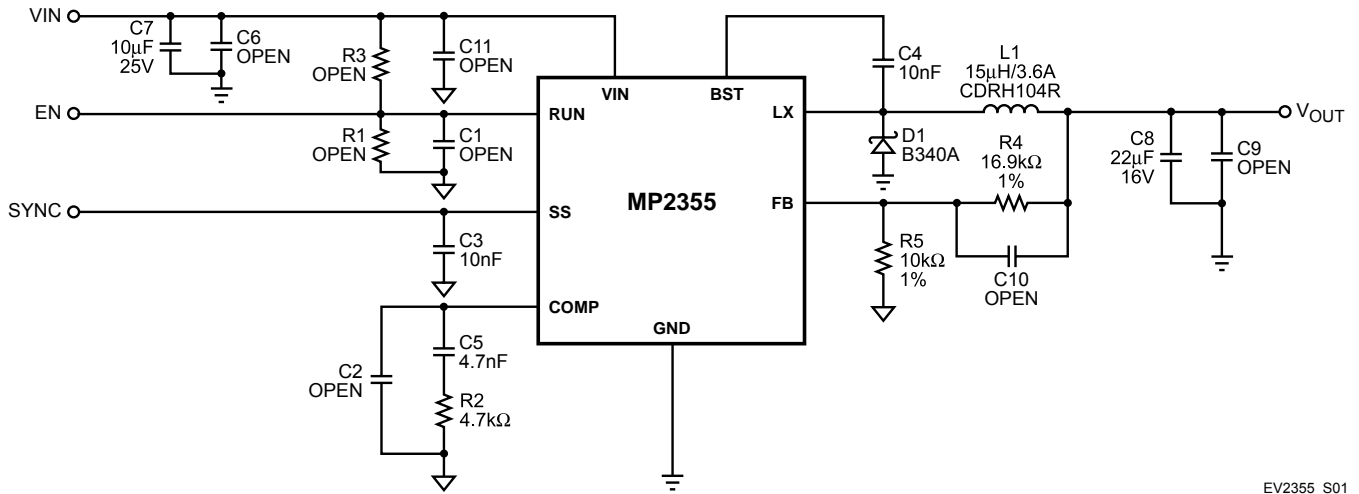
EVALUATION BOARD SCHEMATIC

EV2355_S01

EV2355DN-00A BILL OF MATERIALS

Qty	Ref	Value	Description	Package	Manufacturer	Manufacturer P/N
2	C3, C4	10nF	Ceramic Cap, 50V, X7R	SM0805	AVX	08055C103KAT2A
1	C7	10µF	Ceramic Cap, 25V, X5R	SM1210	AVX	12103D106KAT2A
1	C5	4.7nF	Ceramic Cap, 50V, X7R	SM0805	AVX	08055C472KAT2A
6	C1, C2, C6, C9, C10, C11		Do Not Stuff			
1	C8	22µF	Ceramic Cap, 16V, X5R	SM1210	AVX	1210YD226KAT2A
1	D1		Schottky Diode, 40V, 3A	SMA	Diodes Inc	B340A-13
1	L1	15µH	Inductor, 3.6A	SMD	Sumida	CDRH104R
1	R4	16.9kΩ	Film Res, 1%	SM0805	Panasonic	ERJ-6ENF1692V
1	R2	4.7kΩ	Film Res, 5%	SM0805	Panasonic	ERJ-6GEYJ472V
1	R5	10kΩ	Film Res, 1%	SM0805	Panasonic	ERJ-6ENF1002V
2	R1, R3		Do Not Stuff			
1	U1		DC-DC Converter	SO8	MPS	MP2355DN

PRINTED CIRCUIT BOARD LAYOUT

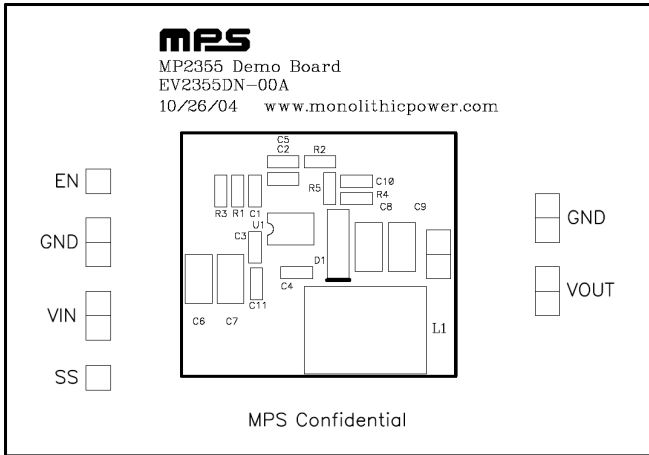

Figure 1—Top Silk Layer

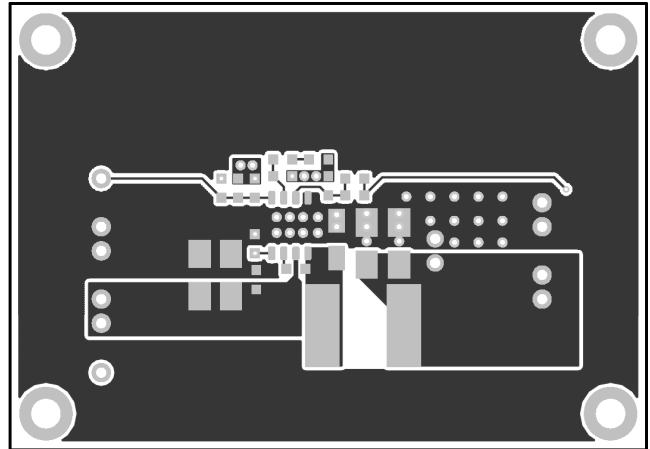

Figure 2—Top Layer

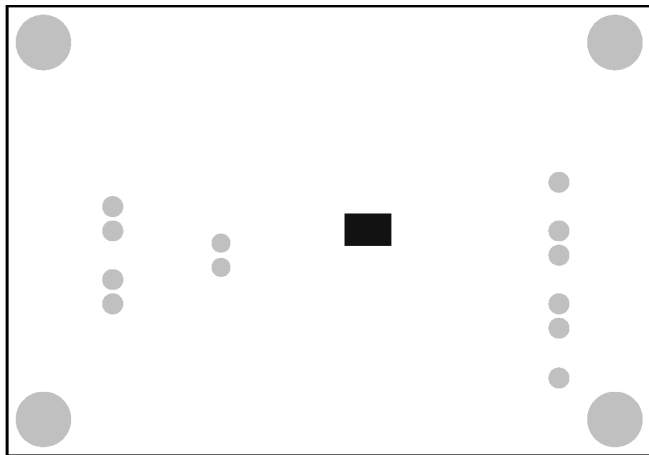

Figure 3— Bottom Mask Layer

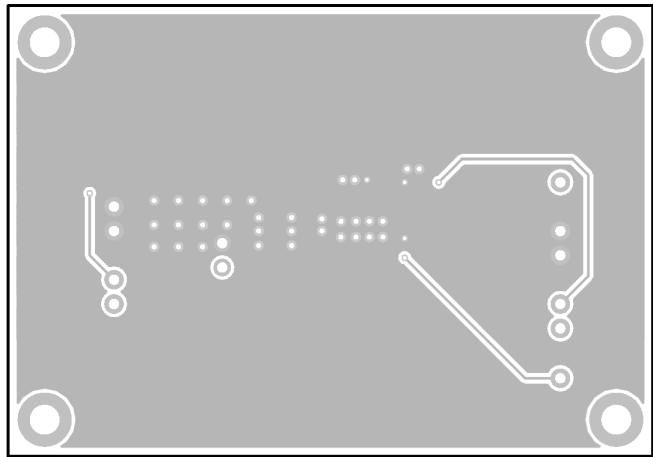

Figure 4— Bottom Layer

QUICK START GUIDE

1. Connect the positive terminal of the load to VOUT pins, and the negative terminal of the load to GND pins
2. Preset the power supply output to 4.75V to 23V and turn off the power supply.
3. Connect the positive terminal of the power supply output to the VIN pin and the negative terminal of the power supply output to the GND pin
4. Turn the power supply on. The MP2355 will automatically startup.
5. To use the Enable function, apply a digital input to EN pin. Drive EN higher than 2.5V to turn on the regulator, drive EN less than 0.7V to turn it off.
6. An input under voltage lockout (UVLO) function can be implemented by the addition of a resistor divider R4 and R5.

The EN threshold is 2.5V, so V_{IN} UVLO threshold is $\left(1 + \frac{R4}{R5}\right) \times 2.5V$

The output voltage of this board is preset to 3.3V. This board is laid out to accommodate most commonly used inductors and output capacitors and to be programmed for most standard output voltages. For other output voltages, please refer to the Application Information section in the MP2355 datasheet.

NOTICE: The information in this document is subject to change without notice. Please contact MPS for current specifications. Users should warrant and guarantee that third party Intellectual Property rights are not infringed upon when integrating MPS products into any application. MPS will not assume any legal responsibility for any said applications.