

Model MDP, 4892, & 4898 Stackable Double Banana Plug with Cable Guide

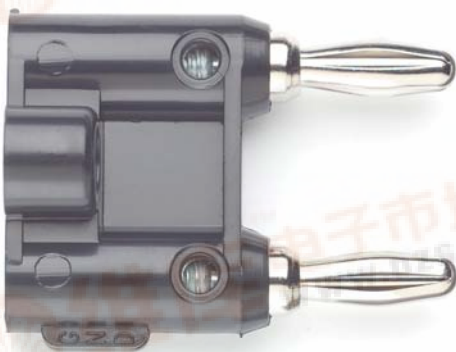

Model MDP, 4892, 4898
Stackable Double Banana Plug with Cable Guide

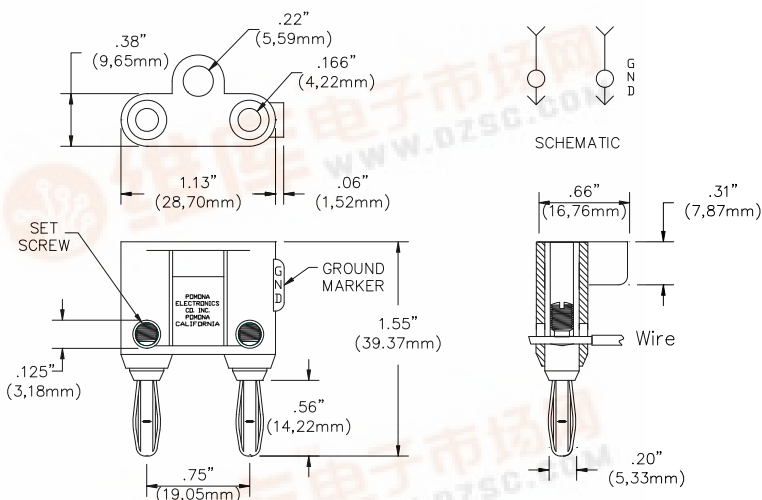

Features

- Simplified attachment of cables or small components by means of set screws.
- For test versatility, banana plugs can be vertically stacked.
- Banana plug spring is Beryllium Copper for long insertion life.
- Model 4898 features Polyphenylene Sulfide for high temperature operation.
- Model 4892 features gold plating for superior electrical connection.

Materials

Banana Plug Body:

MDP & 4898: Nickel Plated Brass
Model 4892: Gold Plated Brass

Spring:

MDP & 4898: Nickel Plated Beryllium Copper
Model 4892: Gold Plated Beryllium Copper

Insulation:

MDP & 4892: ABS
Model 4898: Polyphenylene Sulfide

Set Screws: Zinc Plated Steel, 8-32 Single

Specifications

Operating Voltage:

Hands free usage in controlled voltage environments: 5000 Vrms maximum.

For CE compliance: not intended for hand-held use at voltages above 33 Vrms/70 Vdc.

Current: 15 Amperes

Operating Temperature:

Model MDP & 4892: +122°F (+50°C) Max.
Model 4898: +302°F (+150°C) Max.

Ordering Information

Model: MDP-Color

Colors = 0 (Black), 1 (Brown), 2 (Red), 3 (Orange), 4 (Yellow), 5 (Green), 6 (Blue), 7 (Violet), 8 (Gray), 9 (White)

Model: 4892-0 (Gold Plated, Black)

Model: 4892-2 (Gold Plated, Red)

Model: 4898-0 (Polyphenylene Sulfide, Black)

Model: 4898-6 (Polyphenylene Sulfide, Blue)

Ordering Example: 4892-2, Gold Plated Double Banana Plug, Color: Red

Model: 4914 (replacement set screws 100/pk)

All dimensions are in inches. Tolerances (except noted): .xx = ±.02" (.51 mm), .xxx = ±.005" (.127 mm). All specifications are to the latest revisions. Specifications are subject to change without notice. Registered trademarks are the property of their respective companies.

USA: Sales: 800-490-2361
Technical Support: technicalsupport@pomonatest.com
Fax: 425-446-5844

Europe: 31-(0) 40 2675 150 International: 425-446-5500

Where to Buy: www.pomonaelectronics.com

