

**DESCRIPTION**

The LXM1618-05-4x is a Single Output 4W Direct Drive™ CCFL (Cold Cathode Fluorescent Lamp) Inverter Module specifically designed for driving LCD backlight lamps. It is ideal for driving typical 8.4" to 12.1" panels.

The maximum output current is externally programmable over a range of 5 to 6.5mA in 0.5mA steps to allow the inverter to properly match to a wide array of LCD panel lamp current specifications. The modules include a dimming input that permits brightness control from either a DC voltage source, a PWM signal or an external potentiometer.

LXM1618 modules unlike the LXM1617 series does not provide wide range 'burst' mode dimming, rather dimming is provided by amplitude control of the output current waveform, this limits the potential dim range to typically less than 5:1.

For applications not requiring wide range dimming, amplitude control results in lower ripple on the input supply and reduced potential transient noise generation. Many STN type panels are particularly well suited for current amplitude dimming.

The modules convert DC voltage from the system battery or AC adapter directly to high frequency, high-voltage waves required to ignite and operate CCFL lamps. A 12V input inverter is also available (LXM1618-12-4x).

The modules design is based on Microsemi's new LX1689 backlight controller, which provides a number of cost and performance advantages due to the controller's high level of integration.

Other benefits of this new topology are stable fixed-frequency operation, secondary-side strike-voltage regulation and both open and shorted lamp protection with fault timeout.

**KEY FEATURES**

- Externally Programmable Maximum Output Current
- Easy to Use Brightness Control
- Output Short-Circuit Protection and Automatic Strike-Voltage Regulation and Timeout
- Analog Current Amplitude Dimming Method
- Fixed Frequency Operation
- Rated From -20 to 70°C
- UL60950 E175910

**APPLICATIONS**

- Notebook And Sub-Notebook
- Portable Instrumentation
- Desktop Displays
- Industrial Display Controls

**BENEFITS**

- Compact, Low Profile Design
- Mates to Wide Variety of LCD Panels
- Output Open Circuit Voltage Regulation Minimizes Corona Discharge For High Reliability

**IMPORTANT:** For the most current data, consult MICROSEMI's website: <http://www.microsemi.com>  
Protected by U.S. Patents: 5,923,129; 5,930,121; 6,198,234; Patents Pending

**PRODUCT HIGHLIGHT**

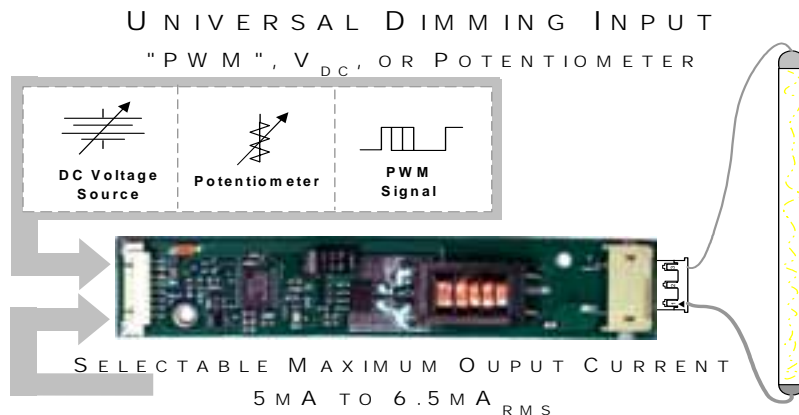

**PACKAGE ORDER INFO**

PART NUMBER	OUTPUT CONNECTOR	INVERTER MATES DIRECTLY TO PANEL CONNECTORS
LXM1618-05-41	JST SM02(8.0)B-BHS-1-TB or Yeon Ho 20015WR-05A00	JST BHR-03VS-1
LXM1618-05-42	JST SM02B-BHSS-1-TB or Yeon Ho 35001WR-02A00	JST BHSR-02VS-1
LXM1618-05-43	Honda QZ-19-A3MYL #02	Honda QZ-19-3F01

**ABSOLUTE MAXIMUM RATINGS (NOTE 1)**

Input Signal Voltage ( $V_{IN1}$ ).....	-0.3V to 6.5V
Input Power .....	5.5W
Output Voltage, no load .....	Internally Limited to 1600V <sub>RMS</sub>
Output Current.....	7.5mA <sub>RMS</sub> (Internally Limited)
Output Power.....	4.0W
Input Signal Voltage ( SLEEP Input) .....	-0.3V to 5.5V
Input Signal Voltage (BRITE).....	-0.3V to 5.5V
Ambient Operating Temperature, zero airflow .....	-20°C to 70°C
Storage Temperature Range .....	-40°C to 85°C

Note 1: Exceeding these ratings could cause damage to the device. All voltages are with respect to Ground. Currents are positive into, negative out of specified terminal.

**RECOMMENDED OPERATING CONDITIONS (R.C.)**

This module has been designed to operate over a wide range of input and output conditions. However, best efficiency and performance will be obtained if the module is operated under the condition listed in the 'R.C.' column. Min. and Max. columns indicate values beyond which the inverter, although operational, will not function optimally.

Parameter	Symbol	Recommended Operating Conditions			Units
		Min	R.C.	Max	
Input Supply Voltage Range (Fully Regulated Lamp Current)	$V_{IN1}$	4.75	5	5.25	V
Input Supply Voltage Range (Functional)		4.5	5	5.5	
Output Power	$P_O$		3.5	4.0	W
Linear BRITE Control Input Voltage Range <sup>1</sup>	$V_{BRT\_ADJ}$	0.65 to 0.9		2.0	V
Lamp Operating Voltage	$V_{LAMP}$	465	550	635*	V <sub>RMS</sub>
Lamp Current (Full Brightness)	$I_{OLAMP}$	5		6.5	mA <sub>RMS</sub>
Operating Ambient Temperature Range	$T_A$	-20		70	°C

<sup>1</sup> The minimum  $V_{BRT\_ADJ}$  voltage depends on the panel characteristics, depending on the panel it can vary from 0.65V to 0.9V

<sup>2</sup> Total output power must not exceed 4W. Higher voltage lamps may require maximum output current to be set lower than 6.5mA<sub>RMS</sub>

**ELECTRICAL CHARACTERISTICS**

Unless otherwise specified, the following specifications apply over the recommended operating condition and ambient temperature of 25°C except where otherwise noted.

Parameter	Symbol	Test Conditions	LXM1618-05-4x			Units
			Min	Typ	Max	
<b>OUTPUT PIN CHARACTERISTICS</b>						
Full Bright Lamp Current	$I_{L(MAX)}$	$V_{BRT\_ADJ} \geq 2.0V_{DC}$ , $\overline{SLEEP} \geq 2.0V$ , $V_{IN1} = 5V_{DC}$ $I_{SET1} = \text{Ground}$ , $I_{SET2} = \text{Ground}$	4.5	5	5.5	mA <sub>RMS</sub>
Full Bright Lamp Current	$I_{L(MAX)}$	$V_{BRT\_ADJ} \geq 2.0V_{DC}$ , $\overline{SLEEP} \geq 2.0V$ , $V_{IN1} = 5V_{DC}$ $I_{SET1} = \text{Ground}$ , $I_{SET2} = \text{Open}$	5.0	5.5	6.0	mA <sub>RMS</sub>
Full Bright Lamp Current	$I_{L(MAX)}$	$V_{BRT\_ADJ} \geq 2.0V_{DC}$ , $\overline{SLEEP} \geq 2.0V$ , $V_{IN1} = 5V_{DC}$ $I_{SET1} = \text{Open}$ , $I_{SET2} = \text{Ground}$	5.5	6	6.5	mA <sub>RMS</sub>
Full Bright Lamp Current	$I_{L(MAX)}$	$V_{BRT\_ADJ} \geq 2.0V_{DC}$ , $\overline{SLEEP} \geq 2.0V$ , $V_{IN1} = 5V_{DC}$ $I_{SET1} = \text{Open}$ , $I_{SET2} = \text{Open}$	6.0	6.5	7.0	mA <sub>RMS</sub>
Min. Average Lamp Current	$I_{L(MIN)}$	$V_{BRT\_ADJ} = 0.65V_{DC}$ , $\overline{SLEEP} \geq 2.0V$ , $V_{IN1} = 5V_{DC}$ $I_{SET1} = I_{SET2} = \text{Ground}$		1.5 *		mA <sub>RMS</sub>
Lamp Start Voltage	$V_{LS}$	-20°C < $T_A$ < 70°C, $V_{IN1} > 4.5V_{DC}$	1300	1400		V <sub>RMS</sub>
Operating Frequency	$f_O$	$V_{BRT\_ADJ} = 2.5V_{DC}$ , $\overline{SLEEP} \geq 2.0V$ , $V_{IN1} = 5V$	76	80	83	kHz

\* The Inverter is capable of a lower output current than may be recommended by the panel manufacturer. It is the user responsibility to set the minimum brightness (BRITE) input at or above the panel specification for minimum current.

**ELECTRICAL CHARACTERISTICS (CONTINUED)**

Unless otherwise specified, the following specifications apply over the recommended operating condition and ambient temperature of 25°C except where otherwise noted.

Parameter	Symbol	Test Conditions	LXM1618-05-4x			Units
			Min	Typ	Max	
<b>BRITE INPUT</b>						
Input Current	I <sub>BRT</sub>	V <sub>BRT_ADJ</sub> = 0V <sub>DC</sub>		-300		μA <sub>DC</sub>
		V <sub>BRT_ADJ</sub> = 3V <sub>DC</sub>		50		μA <sub>DC</sub>
Minimum Input for Max. Lamp Current	V <sub>BRT_ADJ</sub>	I <sub>O(LAMP)</sub> = Maximum Lamp Current		2.0	2.05	V <sub>DC</sub>
Minimum Input for Min. Lamp Current	V <sub>BRT_ADJ</sub>	I <sub>O(LAMP)</sub> = Minimum Lamp Current	0.65*			V <sub>DC</sub>
<b>SLEEP INPUT</b>						
RUN Mode	V <sub>SLEEP</sub>		2.0		V <sub>IN1</sub>	V <sub>DC</sub>
SLEEP Mode	V <sub>SLEEP</sub>		-0.3		0.8	V <sub>DC</sub>
<b>SET<sub>1,2</sub> INPUT</b>						
SET <sub>1,2</sub> Low Threshold	V <sub>L</sub>				0.4	V
Input Current	I <sub>SET</sub>	V <sub>SET</sub> ≤ 0.4V		-300		μA
<b>POWER CHARACTERISTICS</b>						
Sleep Current	I <sub>IN(MIN)</sub>	V <sub>IN1</sub> = 5V <sub>DC</sub> , SLEEP ≤ 0.8V	0.0	5	20	μA <sub>DC</sub>
Run Current	I <sub>RUN</sub>	V <sub>IN1</sub> = 5V <sub>DC</sub> , SLEEP ≥ 2.0V, I <sub>SET1</sub> = Open I <sub>SET2</sub> = Ground, V <sub>LAMP</sub> = 550V <sub>RMS</sub>		830		mA <sub>DC</sub>
Efficiency	η	V <sub>IN1</sub> = 5V <sub>DC</sub> , SLEEP ≥ 2.0V, I <sub>SET1</sub> = Open I <sub>SET2</sub> = Ground, V <sub>LAMP</sub> = 550V <sub>RMS</sub>		80		%

\* The Inverter is capable of a lower output current than may be recommended by the panel manufacturer. It is the user's responsibility to set the minimum brightness (BRITE) input at or above the panel specification for minimum current. This is likely greater than the 0.65V minimum input.

**FUNCTIONAL PIN DESCRIPTION**

CONN	PIN	DESCRIPTION
<b>CN1 (Molex 53261-0890) Mates with 51021-0800 housing, 50079-8100 pins. Mates with LX9501 input cable assembly</b>		
CN1-1	V <sub>IN1</sub>	Main Input Power Supply (4.75V ≤ V <sub>IN1</sub> ≤ 5.25V)
CN1-2		
CN1-3	GND	Power Supply Return
CN1-4		
CN1-5	SLEEP	ON/OFF Control. (0V < SLEEP < 0.8 = OFF, SLEEP ≥ 2.0V = ON)
CN1-6	BRITE	Brightness Control (0.65V to 2.0V <sub>DC</sub> ). 2.0V <sub>DC</sub> gives maximum lamp current.
CN1-7	SET <sub>1</sub>	SET <sub>1</sub> MSB Connecting this pin to ground decreases the output current (see Table 1)
CN1-8	SET <sub>2</sub>	SET <sub>2</sub> LSB Connecting this pin to ground decreases the output current (see Table 1)
<b>CN2 for LXM1618-05-41 and -42 (JST SM02(8.0)B-BHS-1-TB / Yeon Ho 20015WR-05A00 or SM02B-BHSS-1-TB / Yeon Ho 35001WR-02A00)</b>		
CN2-1	V <sub>HI</sub>	High voltage connection to high Side of lamp. Connect to lamp terminal with shortest lead length. <b>DO NOT</b> connect to Ground.
CN2-2	V <sub>LO</sub>	Connection to low side of lamp. Connect to lamp terminal with longer lead length. <b>DO NOT</b> connect to Ground
<b>CN2 for LXM1618-05-43 (Honda QZ-19-A3MYL #02)</b>		
CN2-3	V <sub>HI</sub>	High voltage connection to high side of lamp. Connect to lamp terminal with shortest lead length. <b>DO NOT</b> connect to Ground.
CN2-1	V <sub>LO</sub>	Connection to low side of lamp. Connect to lamp terminal with longer lead length. <b>DO NOT</b> connect to Ground

**TABLE 1 SETTING OUTPUT CURRENT**

**OUTPUT CURRENT SETTINGS**

SET <sub>1</sub> (Pin 7)	SET <sub>2</sub> (Pin 8)	Nominal Output Current
Open*	Open*	6.5mA
Open*	Ground	6.0mA
Ground	Open*	5.5mA
Ground	Ground	5.0mA

\* If driven by a logic signal it should be open collector or open drain only, not a voltage source.

**PHYSICAL DIMENSIONS**

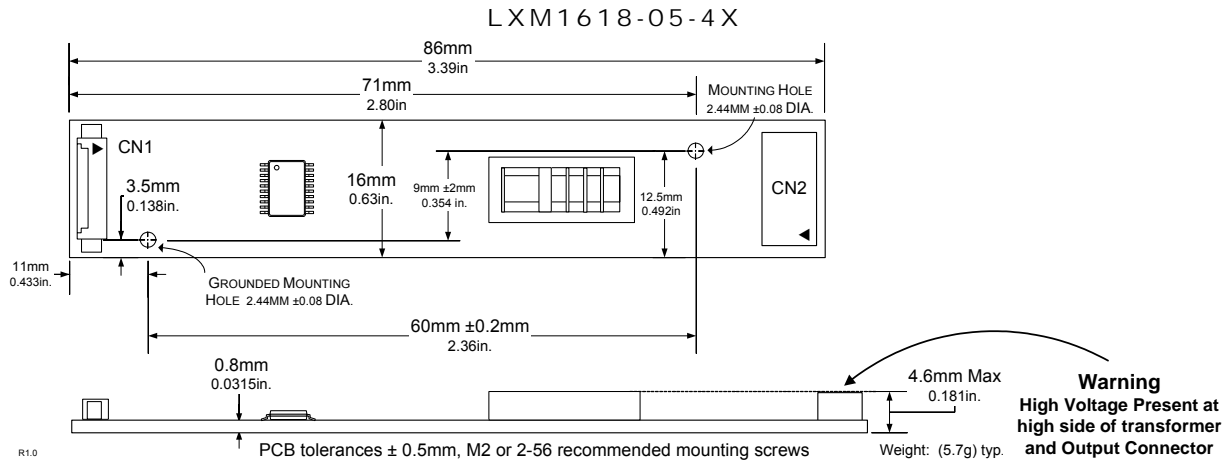

All dimensions are in millimeters, inches are for reference only

**SIMPLIFIED BLOCK DIAGRAM**

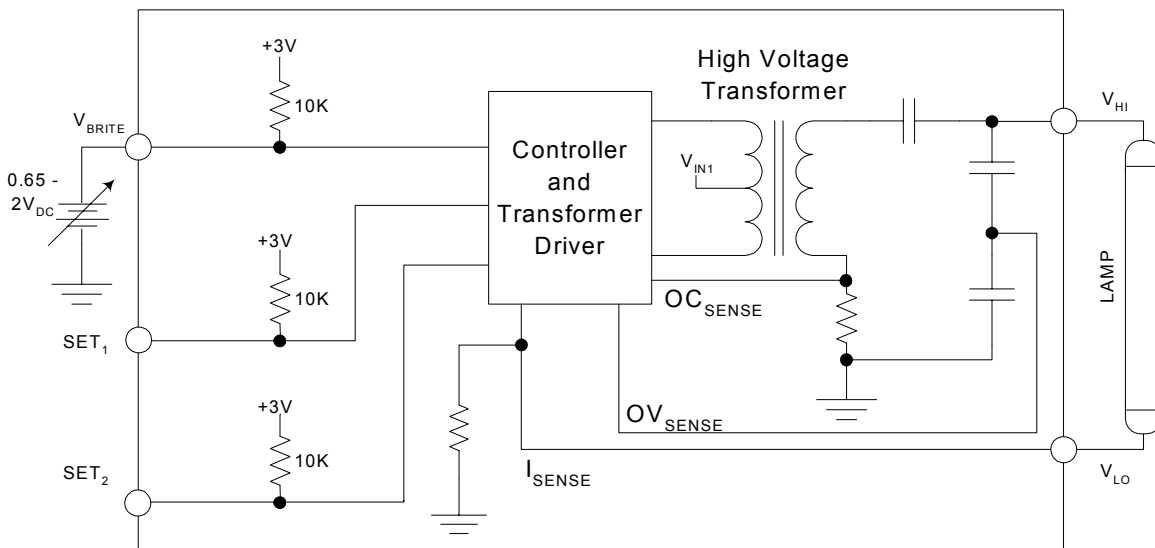

TYPICAL APPLICATION

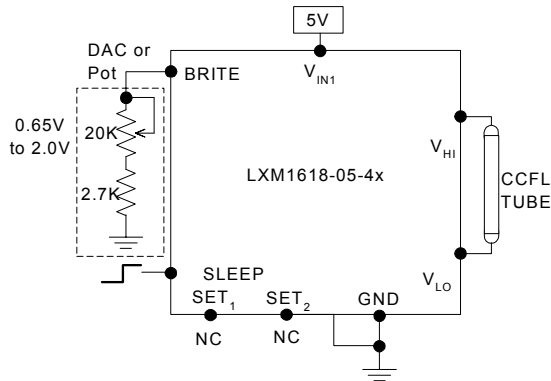

Figure 1 – Brightness Control (output current set to maximum)

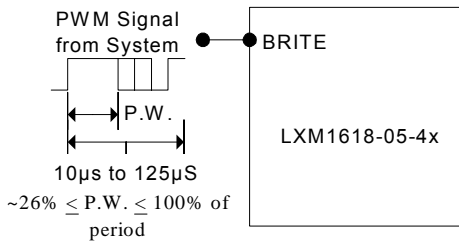
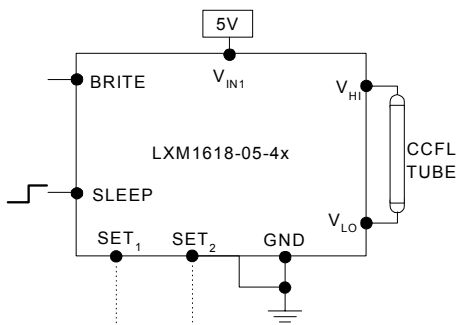

Figure 1A – PWM Brightness Control



L	L	5.0mA <sub>RMS</sub>
L	H	5.5mA <sub>RMS</sub>
H	L	6.0mA <sub>RMS</sub>
H	H	6.5mA <sub>RMS</sub>

L=GND; H=Open

Figure 2 – Max Output Current (SET<sub>1</sub> and SET<sub>2</sub> Inputs)

- The brightness control may be a voltage output DAC or other voltage source, a digital pot or 20K manual pot. The inverter contains an internal 10K pull-up to 3V to bias the pot add a 2.7K resistor to set the lower threshold voltage. A 3.3V Logic Level PWM signal from a micro-controller may also be used as shown in Figure 1A.
- If you need to turn the inverter ON/OFF remotely, connect to TTL logic signal to the SLEEP input.
- Connect V<sub>HI</sub> to high voltage wire from the lamp. Connect V<sub>LO</sub> to the low voltage wire (wire with thinner insulation). Never connect V<sub>LO</sub> to circuit ground as this will defeat lamp current regulation. If both lamp wires have heavy high voltage insulation, connect the longest wire to V<sub>LO</sub>. This wire is typically white.
- Use the SET<sub>1</sub> and SET<sub>2</sub> (see Figure 2) inputs to select the desired maximum output current. Using these two pins in combination allows the inverter to match a wide variety of panels from different manufactures. Generally the best lamp lifetime and efficiency correlates with driving the CCFL at the manufactures nominal current setting. However the SET<sub>1</sub> and SET<sub>2</sub> inputs allow the user the flexibility to adjust the current to the maximum allowable output current to increase panel brightness at the expense of some reduced lamp life.
- Although the SET pins are designed such that just leaving them open or grounding them is all that is needed to set the output current, they can also be actively set. Using an open collector or open drain logic signal will allow you to reduce the lamp current for situations where greater dim range is required, as an example in nighttime situations. In conjunction with a light sensor or other timer the panel could be set to higher brightness (maximum output current) for daytime illumination and lower brightness (minimum or typical output current) at nighttime. Since the dim ratio is a factor the peak output current, using this technique the effective dim ratio can be increased. Conversely the SET inputs could be used to overdrive the lamp temporarily to facilitate faster lamp warm up at initial lamp turn on. Of course any possible degradation on lamp life from such practices is the users responsibility as not all lamps are designed to be overdriven.
- The inverter has a built in fault timeout function. If the output is open (lamp disconnected or broken) or shorted the inverter will attempt to strike the lamp for several seconds. After about 2 seconds without success the inverter will shutdown. In order to restart the inverter it is necessary to toggle the sleep input or cycle the V<sub>IN1</sub> input supply.



**Microsemi**  
INTEGRATED PRODUCTS

[查询"LXM1618-05-41"供应商](#)

PanelMatch™

LXM1618-05-4x

5V 4W CCFL Programmable Inverter Module

PRODUCTION DATASHEET

NOTES

PRODUCTION DATA – Information contained in this document is proprietary to Microsemi and is current as of publication date. This document may not be modified in any way without the express written consent of Microsemi. Product processing does not necessarily include testing of all parameters. Microsemi reserves the right to change the configuration and performance of the product and to discontinue product at any time.