

# 2SK3608-01L,S,SJ

查询"2SK3608"供应商  
**FUJI POWER MOSFET**  
**Super FAP-G Series**

## N-CHANNEL SILICON POWER MOSFET

### Features

- High speed switching
- Low on-resistance
- No secondary breakdown
- Low driving power
- Avalanche-proof

### Applications

- Switching regulators
- UPS (Uninterruptible Power Supply)
- DC-DC converters

### Maximum ratings and characteristic Absolute maximum ratings

● (Tc=25°C unless otherwise specified)

Item	Symbol	Ratings	Unit
Drain-source voltage	V <sub>DS</sub>	200	V
	V <sub>DSX</sub> *5	170	V
Continuous drain current	I <sub>D</sub>	±13	A
Pulsed drain current	I <sub>D(puls)</sub>	±52	A
Gate-source voltage	V <sub>GS</sub>	±30	V
Non-repetitive Avalanche current	I <sub>AS</sub> *2	13	A
Maximum Avalanche Energy	E <sub>AS</sub> *1	175	mJ
Maximum Drain-Source dV/dt	dV <sub>DS</sub> /dt *4	20	kV/μs
Peak Diode Recovery dV/dt	dV/dt *3	5	kV/μs
Max. power dissipation	P <sub>D</sub>	T <sub>a</sub> =25°C	1.67
		T <sub>c</sub> =25°C	50
Operating and storage temperature range	T <sub>ch</sub>	+150	°C
	T <sub>stg</sub>	-55 to +150	°C

\*1 L=1.65mH, V<sub>CC</sub>=48V \*2 T<sub>ch</sub>≤150°C \*3 I<sub>F</sub>≤-I<sub>D</sub>, -di/dt=50A/μs, V<sub>CC</sub>≤BV<sub>DSS</sub>, T<sub>ch</sub>≤150°C

\*4 V<sub>DS</sub> ≤ 200V \*5 V<sub>GS</sub>=-30V

### Electrical characteristics (Tc =25°C unless otherwise specified)

Item	Symbol	Test Conditions	Min.	Typ.	Max.	Units
Drain-source breakdown voltage	V <sub>(BR)DSS</sub>	I <sub>D</sub> = 250μA V <sub>GS</sub> =0V	200			V
Gate threshold voltage	V <sub>GS(th)</sub>	I <sub>D</sub> = 250μA V <sub>DS</sub> =V <sub>GS</sub>	3.0		5.0	V
Zero gate voltage drain current	I <sub>DSS</sub>	V <sub>DS</sub> =200V V <sub>GS</sub> =0V			25	μA
		V <sub>DS</sub> =160V V <sub>GS</sub> =0V			250	
Gate-source leakage current	I <sub>GSS</sub>	V <sub>GS</sub> =±30V V <sub>DS</sub> =0V		10	100	nA
Drain-source on-state resistance	R <sub>DS(on)</sub>	I <sub>D</sub> =6.5A V <sub>GS</sub> =10V		131	170	mΩ
Forward transconductance	g <sub>fs</sub>	I <sub>D</sub> =6.5A V <sub>DS</sub> =25V	5.5	11		S
Input capacitance	C <sub>iss</sub>	V <sub>DS</sub> =75V		770	1155	pF
Output capacitance	C <sub>oss</sub>	V <sub>GS</sub> =0V		110	165	
Reverse transfer capacitance	C <sub>rss</sub>	f=1MHz		5	7.5	
Turn-on time t <sub>on</sub>	td(on)	V <sub>CC</sub> =48V I <sub>D</sub> =6.5A		12	18	ns
	t <sub>r</sub>	V <sub>GS</sub> =10V		2.6	3.9	
Turn-off time t <sub>off</sub>	td(off)	R <sub>GS</sub> =10 Ω		22	33	
	t <sub>f</sub>			6.1	9.2	
Total Gate Charge	Q <sub>G</sub>	V <sub>CC</sub> =100V		21	31.5	nC
Gate-Source Charge	Q <sub>GS</sub>	I <sub>D</sub> =13A		8	12	
Gate-Drain Charge	Q <sub>GD</sub>	V <sub>GS</sub> =10V		5	7.5	
Avalanche capability	I <sub>AV</sub>	L=100μH T <sub>ch</sub> =25°C	13			A
Diode forward on-voltage	V <sub>SD</sub>	I <sub>F</sub> =13A V <sub>GS</sub> =0V T <sub>ch</sub> =25°C		1.10	1.65	V
Reverse recovery time	t <sub>rr</sub>	I <sub>F</sub> =13A V <sub>GS</sub> =0V		0.15		μs
Reverse recovery charge	Q <sub>rr</sub>	-di/dt=100A/μs T <sub>ch</sub> =25°C		0.88		μC

### Thermal characteristics

Item	Symbol	Test Conditions	Min.	Typ.	Max.	Units
Thermal resistance	R <sub>th(ch-c)</sub>	channel to case			2.5	°C/W
	R <sub>th(ch-a)</sub>	channel to ambient			75.0	°C/W

### Outline Drawings (mm)

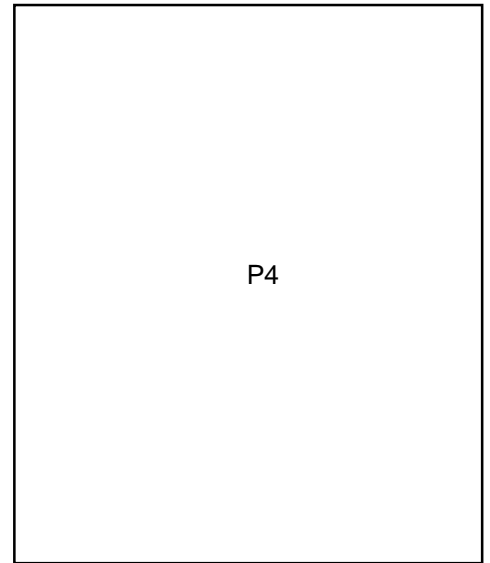

### Equivalent circuit schematic

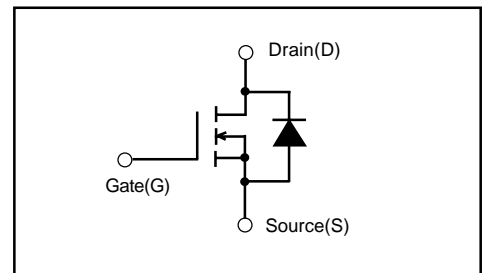

[查询"2SK3608"供应商](#)

## Characteristics

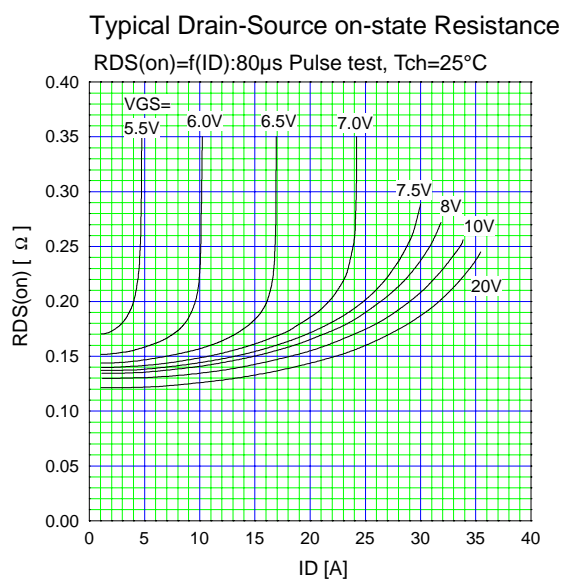
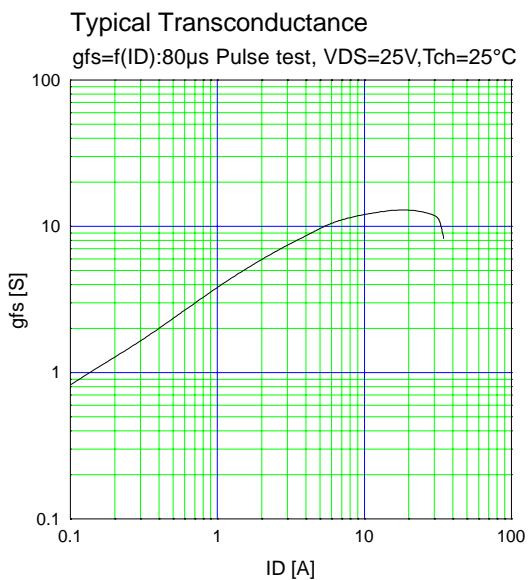
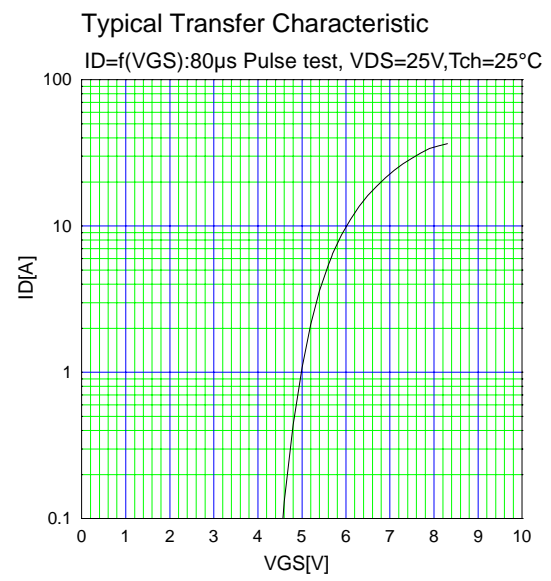
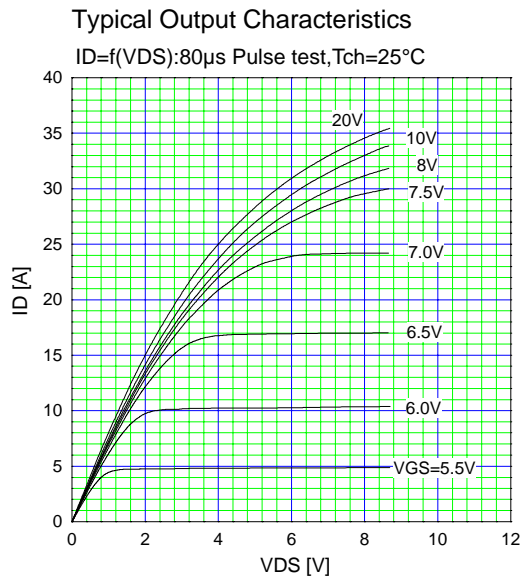
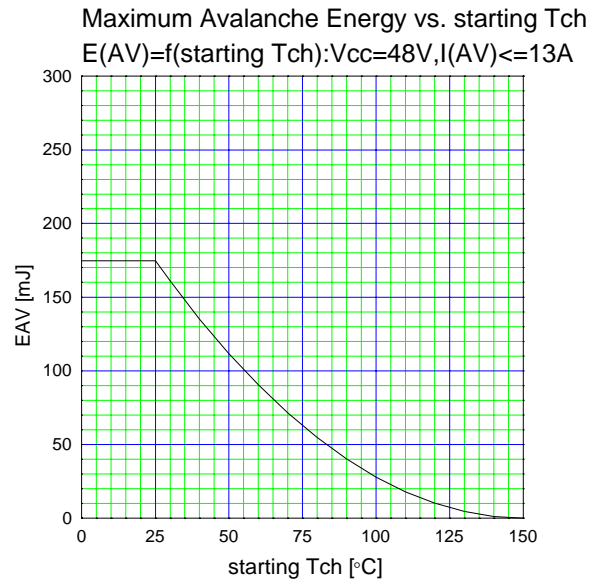
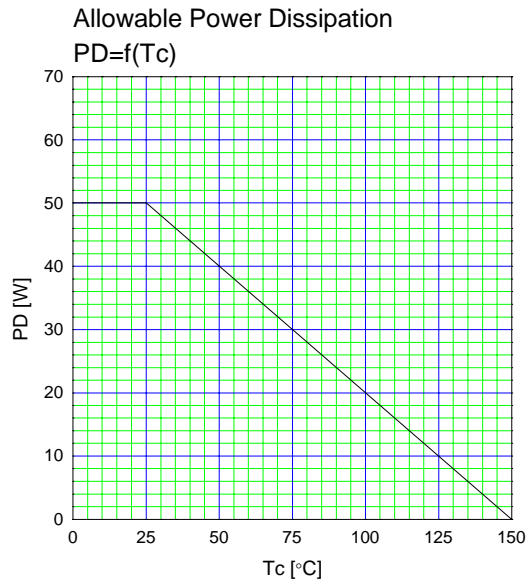

[查询"2SK3608"供应商](#)

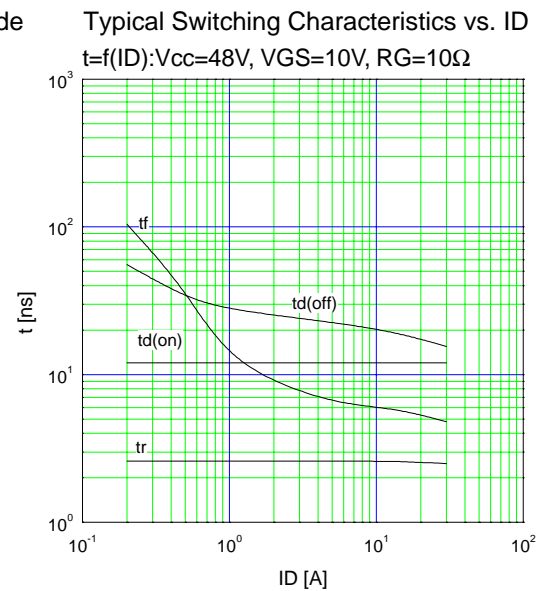
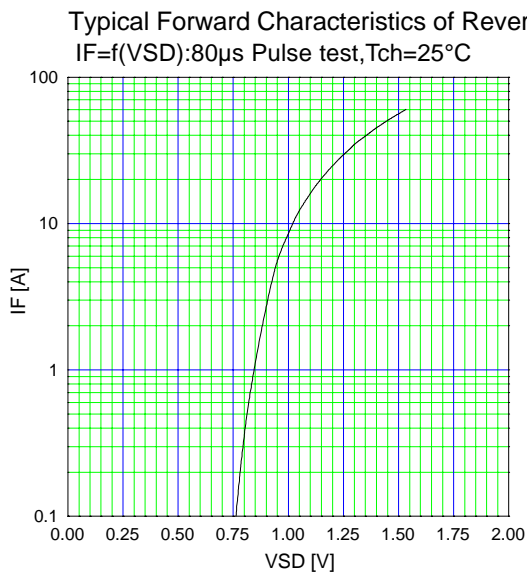
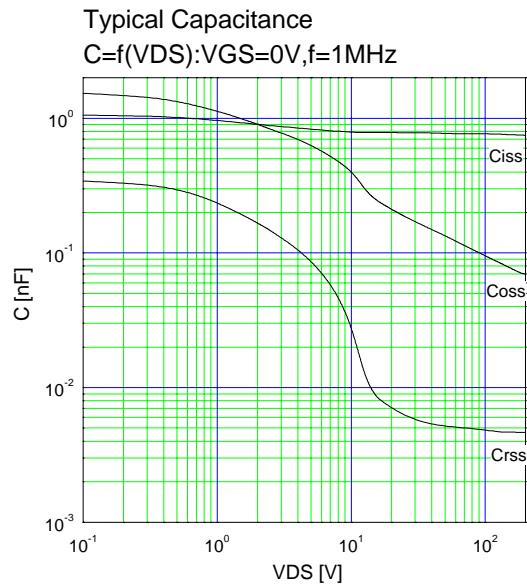
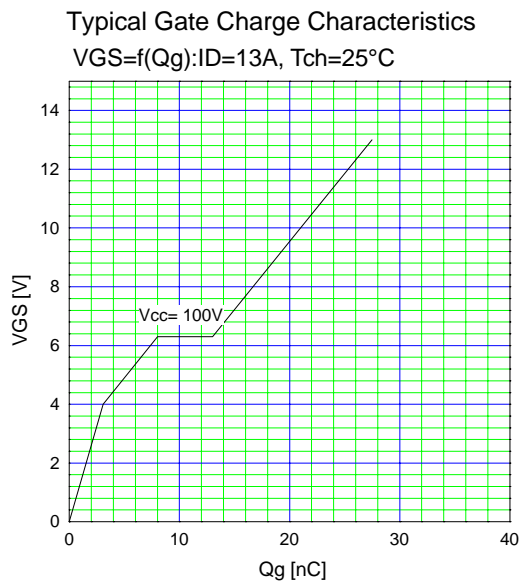
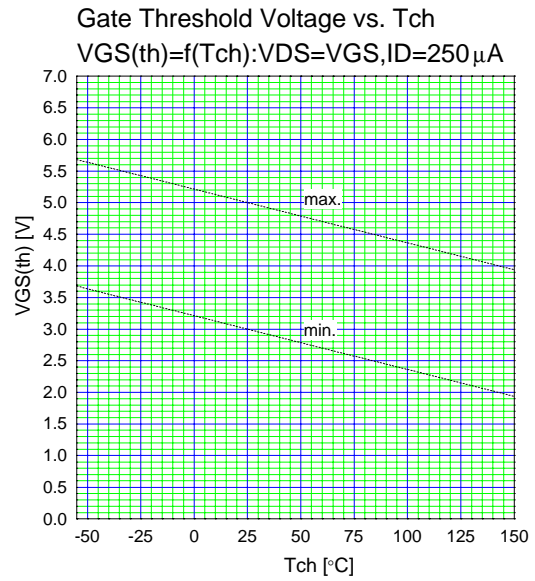
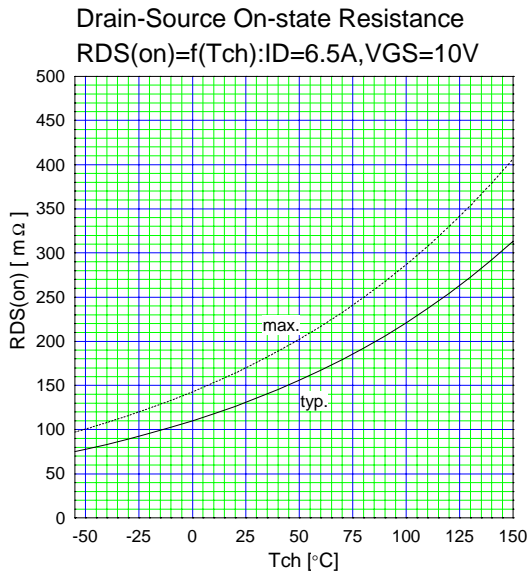

[查询"2SK3608"供应商](#)

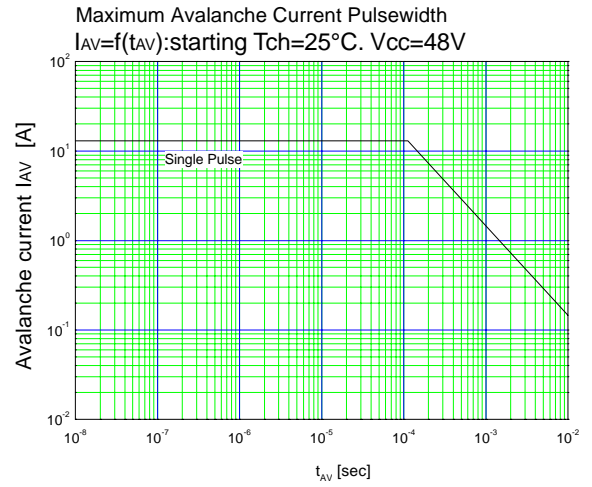
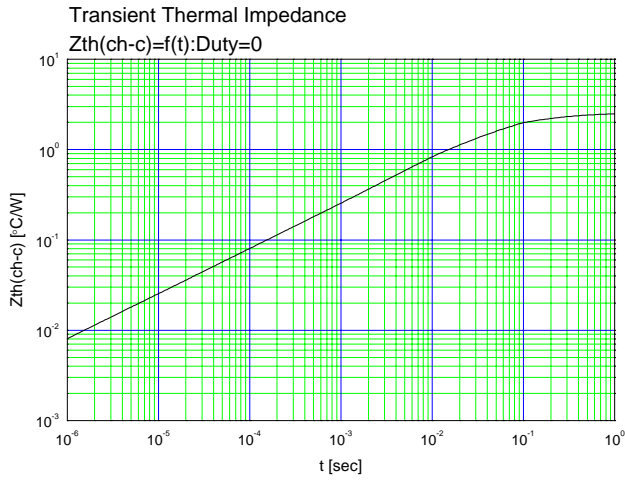

## Outline Drawings (mm)

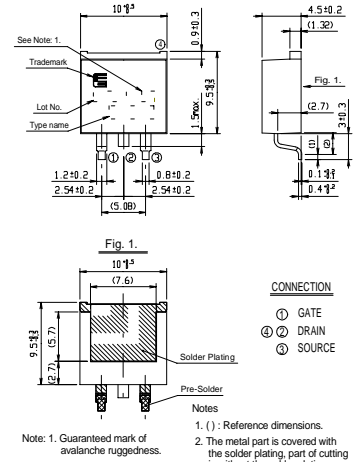
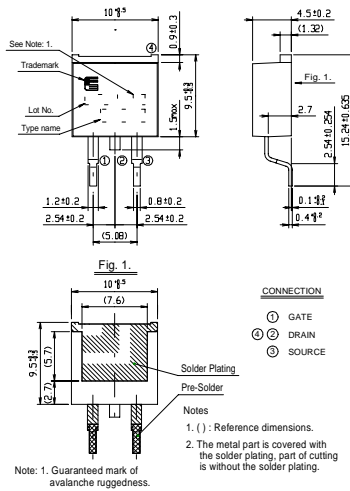
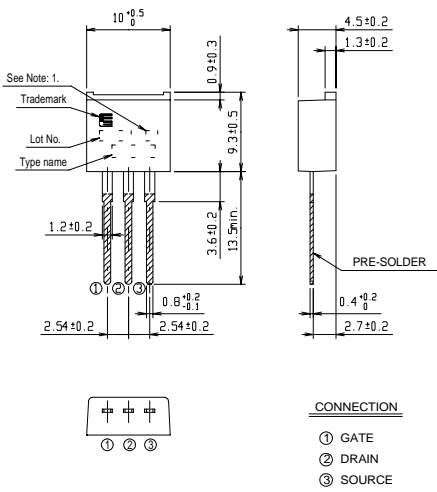

Note: 1. Guaranteed mark of avalanche ruggedness.