



v04.1109



HMC-C200

DIELECTRIC RESONATOR OSCILLATOR MODULE, 8.0 - 8.3 GHz



Typical Applications

The HMC-C200 DRO Module is ideal for:

- Test & Measurement Equipment
- Lab Instrumentation
- Industrial / Medical Equipment
- Military, EW, ECM & Communications

Functional Diagram

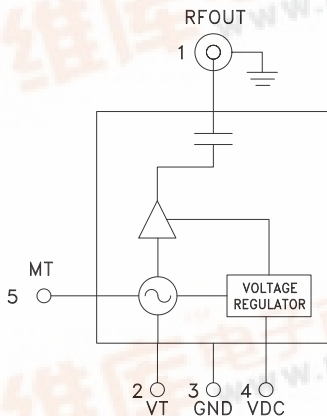

Features

- Tuning Frequency: 8.0 - 8.3 GHz
- Low SSB Phase Noise: -122 dBc/Hz @ 10 kHz Offset
- Single Positive Supply: +6 to +15V @ 116 mA
- Internal Voltage Regulator
- Internal Buffer Amplifier
- High Output Power: +14.5 dBm
- 40°C to + 85°C Operating Temperature

General Description

The HMC-C200 is a high performance dielectric resonator oscillator (DRO) that incorporates Hittite's ultra-low phase noise technology and provides -122 dBc/Hz SSB phase noise at 10 kHz offset. The output buffer also provides 14.5 dBm of output power. Internal temperature compensation allows this DRO to operate over a temperature range of -40°C to + 85°C with a frequency drift of only 2ppm/°C. The Vtune port accepts an analog tuning voltage from +7 to +12V and provides a range of ±1 MHz from the center frequency. The DRO is packaged in a small, moisture sealed 1.5"x1.5" (36 x 36 mm) module with a field replaceable SMA Connector. The HMC-C200 can be used as a drop-in module if the SMA connector is not used.

Electrical Specifications, $T_A = +25^\circ \text{C}$, Frequency = 8.2 GHz, VDC = +6.5V

Parameter	Min.	Typ.	Max.	Units
Frequency Range	8.0	8.2	8.3	GHz
Frequency Accuracy		±250		kHz
Power Output, Center Frequency	12	13.5		dBm
SSB Phase Noise @ 1 kHz Offset, Center Frequency		-95		dBc/Hz
SSB Phase Noise @ 10 kHz Offset, Center Frequency	-117	-122		dBc/Hz
SSB Phase Noise @ 100 kHz Offset, Center Frequency		-140		dBc/Hz
SSB Phase Noise @ 1 MHz Offset, Center Frequency		-150		dBc/Hz
Tune Voltage (VT)	7	9	12	V
Electric Tuning Range		±1		MHz
2nd Harmonic (2Fo)		-28		dBc
3rd Harmonic (3Fo)		-35		dBc





v03.1009



HMC-C200

DIELECTRIC RESONATOR OSCILLATOR MODULE, 8.0 - 8.3 GHz

Electrical Specifications (Continued)

Parameter	Min.	Typ.	Max.	Units
Frequency Pushing		5		kHz/V
Frequency Pulling (into 2.0:1 VSWR)		5		kHz pp
Output Return Loss		12		dB
Frequency Drift Rate (Temperature)		2		ppm/°C
Voltage Supply (VDC)	6		15	V
Supply Current @ VDC = +6.5V		116		mA
Frequency Drift vs. Time @ 25°C		1		ppm/year

Phase Noise vs. Temperature @ 8.2 GHz

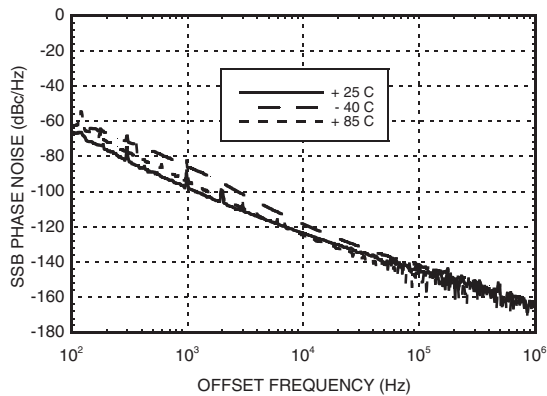

Output Frequency vs. Temperature

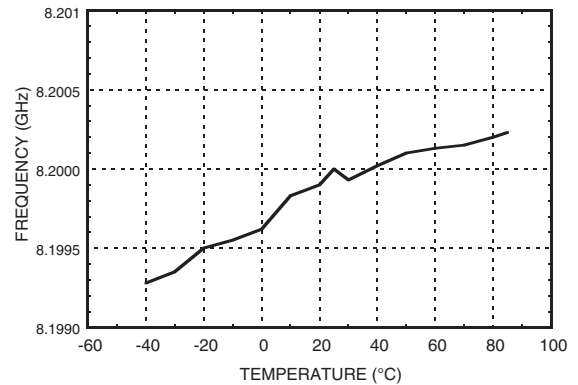

Output Power vs. Temperature @ 8.2 GHz

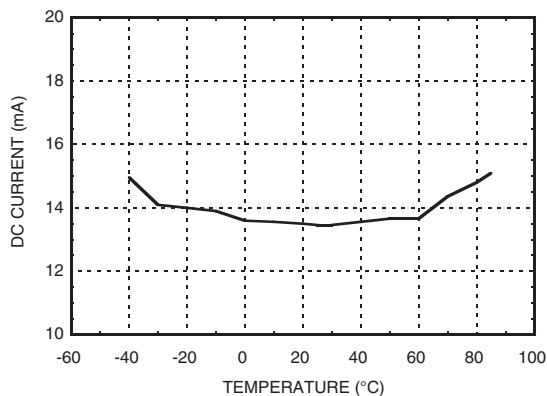

VDC Current vs. Temperature @ 8.2 GHz

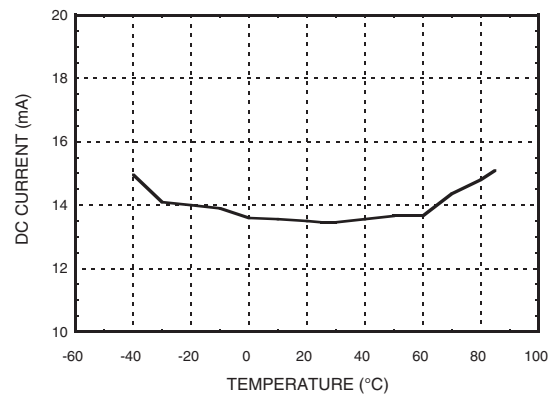



MICROWAVE CORPORATION v03.1009



HMC-C200

DIELECTRIC RESONATOR OSCILLATOR MODULE, 8.0 - 8.3 GHz

Frequency & Power vs. Tuning Voltage

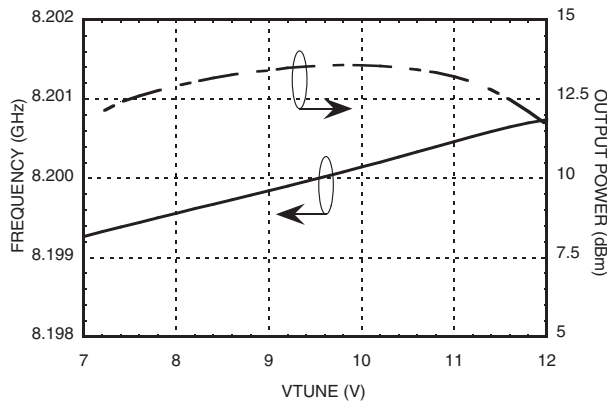

Vibration Sensitivity

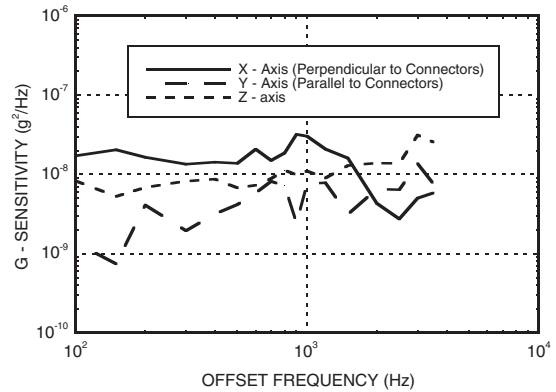

Absolute Maximum Ratings

VDC	+15V
VT	0 to +15V
Storage Temperature	-65 to +150 °C
Operating Temperature	-40 to +85 °C

Pin Descriptions

Pin Number	Function	Description	Interface Schematic
1	RFOUT	RF output (AC coupled) uses a female SMA connector.	
2	VT	Control Voltage and Modulation Input uses a female SMA connector. Modulation bandwidth dependent on drive source impedance.	
3	GND	Must be connected to power supply ground.	
4	VDC	Supply Voltage Vdc = +6V to +15V.	
5	MT	Mechanical Tuning Screw. (This is initially set at the factory per customer specified frequency, See Application Notes herein)	

Ordering Instructions

Each HMC-C200 DRO requires tuning to a specific frequency in the 8.0 - 8.3 GHz range. To order an HMC-C200, this frequency must be specified at the time of purchase. Hittite guarantees a ± 250 kHz range around this specified frequency upon delivery. Please refer to the Application Notes for more details. For example, when ordering an HMC-C200 centered at 8.200 GHz, specify HMC-C200-8200.

Outline Drawing

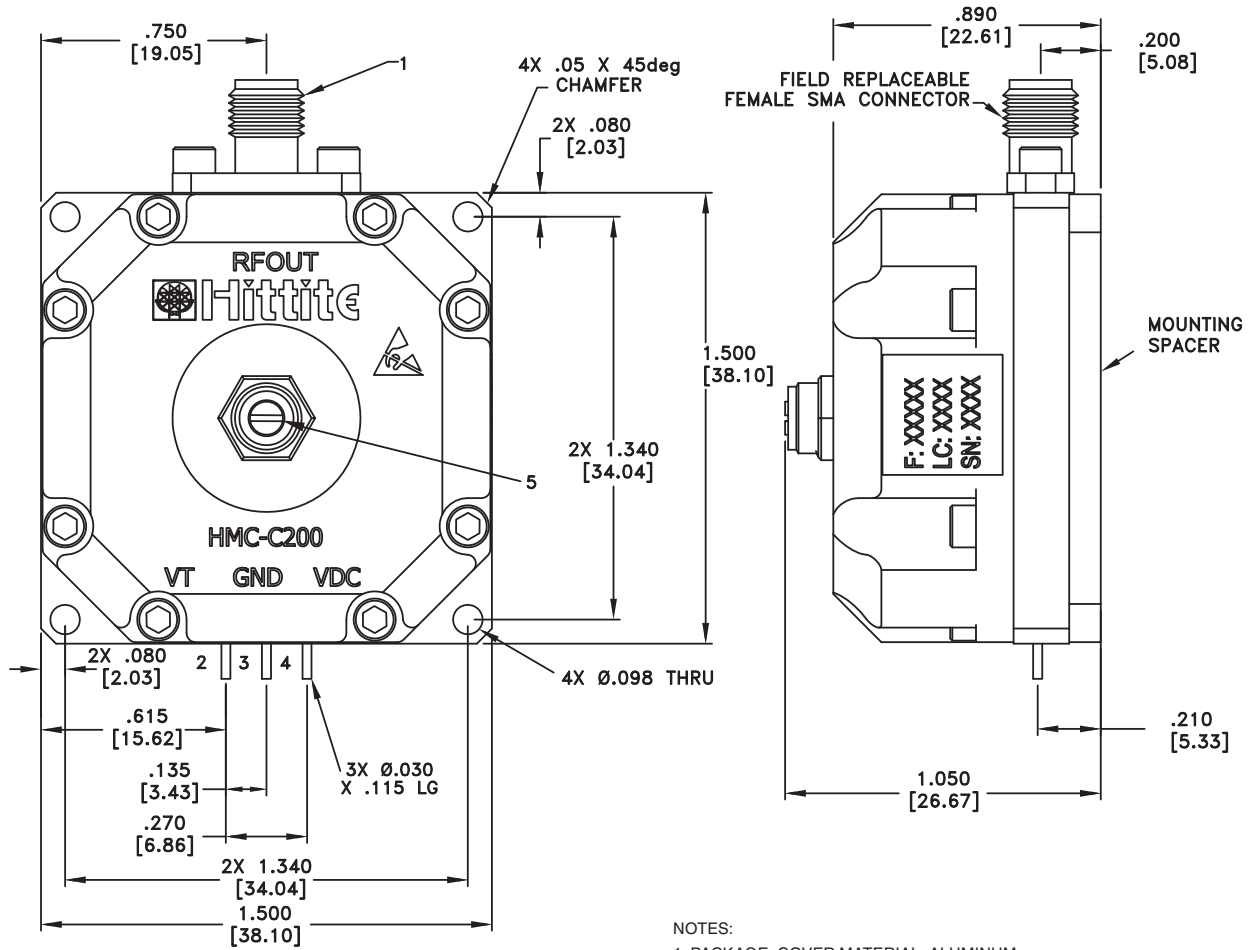

Package Information

Package Type	C-18
--------------	------

NOTES:

1. PACKAGE, COVER MATERIAL: ALUMINUM.
2. FINISH: GOLD PLATE OVER NICKEL PLATE.
3. MOUNTING SPACER: NICKEL PLATED ALUMINUM.
4. ALL DIMENSIONS ARE IN INCHES [MILLIMETERS].
5. TOLERANCES: UNLESS OTHERWISE SPECIFIED
 - 5.1 .XX = $\pm .02$ [51]
 - 5.2 .XXX = $\pm .010$ [25]



HMC-C200

DIELECTRIC RESONATOR OSCILLATOR MODULE, 8.0 - 8.3 GHz

Application Notes

DRO Tuning Procedure:

1. A mechanical tuning screw (MT) is provided that can adjust the center frequency by approximately ± 20 MHz from the factory setting. This screw is set at factory per customer specified frequency. Adjusting the screw clockwise increases the frequency while turning the screw counterclockwise decreases the frequency. The mechanical tuning screw (MT) has stops at either end of its approximately 8 turn range. **Do not attempt to force screw the past stops.**
2. Connect the RF output to a Spectrum Analyzer and adjust the mechanical tuner (MT) to set the output frequency to within 1 MHz of the desired value.
3. Set Spectrum Analyzer settings for a 10 MHz span centered on the desired output frequency. Change the Reference Value of the Spectrum Analyzer to be approximately 15 dBm and change the vertical scale to be 1dB / division such that the peak oscillation frequency is visible on the screen.
4. Use the tune voltage (VT) to maximize the DRO output power and note the frequency. **Note: The tune voltage should never be adjusted higher than +15V.**
5. If the frequency is meeting the new requirement and the output power is greater than 12 dBm, then the tuning procedure is complete. If the frequency is not meeting the requirement then carefully readjust the mechanical tuner (MT) and tune voltage (VT) until the output frequency is within the required range.

Please Note:

1. The tune voltage (VT) sustains oscillation over a fairly narrow range (approximately 1 MHz) before output power, temperature stability and phase noise performance starts to degrade. In some cases it is possible for the tune voltage (VT) to be adjusted to the point where oscillation stops. Therefore, the mechanical tuning screw (MT) should be used as a coarse tune and the tune voltage (VT) is effectively a fine tune. In PLL applications where the tune voltage (VT) is used within the loop, this limited voltage range must be considered during the design of the loop. A limiting circuit must be used to keep the VT voltage within the optimal range.
2. If the output power is less than 12 dBm then the DRO may be at the correct frequency but the phase noise performance and the stability over temperature may both have been degraded. It is therefore recommended that the customer verify phase noise and stability after custom tuning.



v03.1009



HMC-C200

DIELECTRIC RESONATOR OSCILLATOR MODULE, 8.0 - 8.3 GHz

Fixed Output Frequency Application

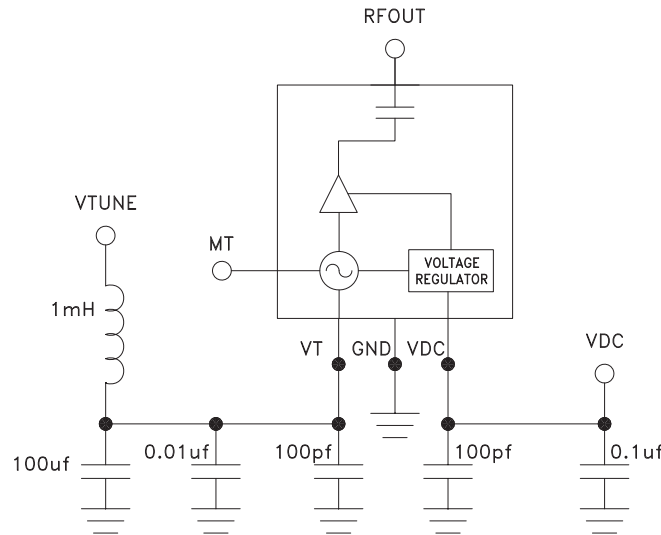

Phase Locked Application

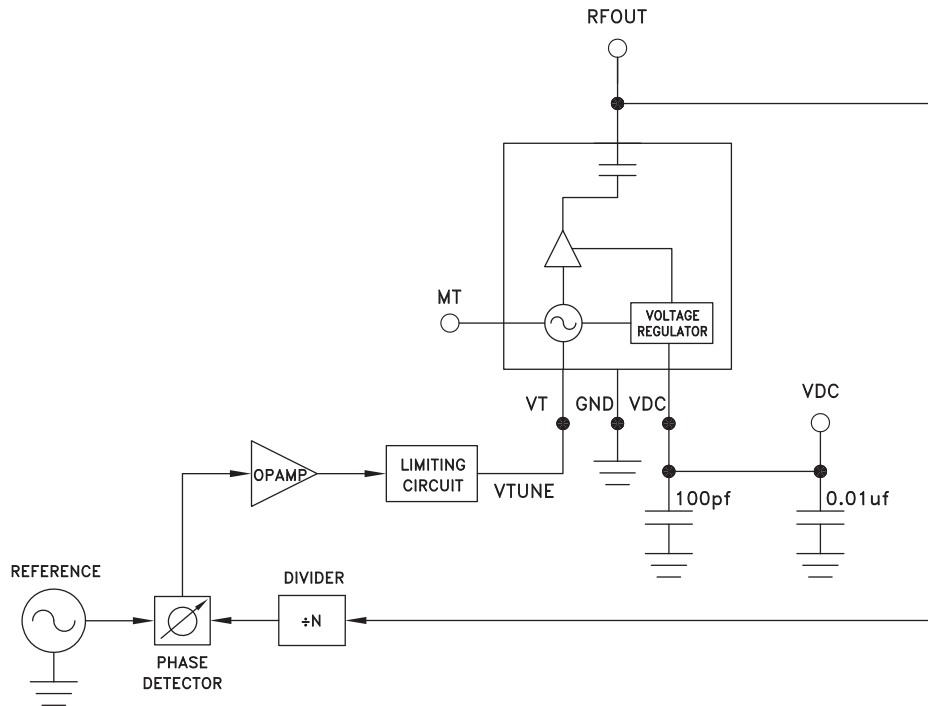

This datasheet has been downloaded from:

www.EEworld.com.cn

Free Download

Daily Updated Database

100% Free Datasheet Search Site

100% Free IC Replacement Search Site

Convenient Electronic Dictionary

Fast Search System

www.EEworld.com.cn