

查询"EC27"供应商

EC27 Series



ECLIPTEK[®]
CORPORATION

- RoHS Compliant (Pb-Free)
- LVHCMOS output
- 2.5V Supply Voltage
- Ceramic SMD package
- Stability to ± 20 ppm
- Standby Function
- Available on Tape and Reel

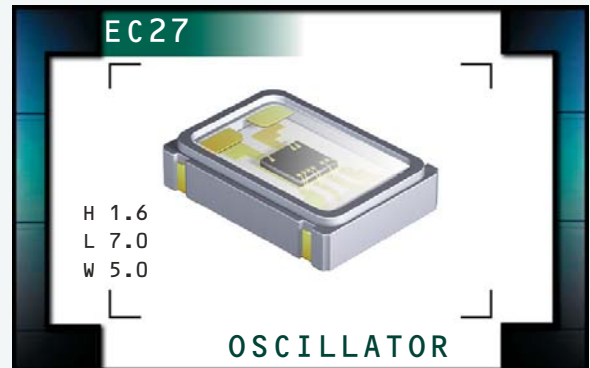

ELECTRICAL SPECIFICATIONS

Frequency Range (F₀)	1.544MHz to 125.000MHz, 125.009MHz, 125.00937MHz, 125.010MHz, 127.000MHz, 128.000MHz, 130.000MHz, 132.000MHz, 133.000MHz, 133.333MHz, 137.472MHz, 142.850MHz, and 150.000MHz																
Operating Temperature Range (OTR)	0°C to 70°C or -40°C to 85°C																
Storage Temperature Range (STR)	-55°C to 125°C																
Supply Voltage (V_{DD})	2.5V _{DC} $\pm 5\%$																
Input Current (I_{DD})	<table border="0"> <tbody> <tr> <td>1.544MHz to 9.999MHz</td> <td>3mA Maximum</td> </tr> <tr> <td>10.000MHz to 24.999MHz</td> <td>5mA Maximum</td> </tr> <tr> <td>25.000MHz to 34.999MHz</td> <td>8mA Maximum</td> </tr> <tr> <td>35.000MHz to 49.999MHz</td> <td>15mA Maximum</td> </tr> <tr> <td>50.000MHz to 69.999MHz</td> <td>20mA Maximum</td> </tr> <tr> <td>70.000MHz to 110.000MHz</td> <td>25mA Maximum</td> </tr> <tr> <td>110.001MHz to 125.000MHz</td> <td>35mA Maximum</td> </tr> <tr> <td>125.001MHz to 150.000MHz</td> <td>45mA Maximum</td> </tr> </tbody> </table>	1.544MHz to 9.999MHz	3mA Maximum	10.000MHz to 24.999MHz	5mA Maximum	25.000MHz to 34.999MHz	8mA Maximum	35.000MHz to 49.999MHz	15mA Maximum	50.000MHz to 69.999MHz	20mA Maximum	70.000MHz to 110.000MHz	25mA Maximum	110.001MHz to 125.000MHz	35mA Maximum	125.001MHz to 150.000MHz	45mA Maximum
1.544MHz to 9.999MHz	3mA Maximum																
10.000MHz to 24.999MHz	5mA Maximum																
25.000MHz to 34.999MHz	8mA Maximum																
35.000MHz to 49.999MHz	15mA Maximum																
50.000MHz to 69.999MHz	20mA Maximum																
70.000MHz to 110.000MHz	25mA Maximum																
110.001MHz to 125.000MHz	35mA Maximum																
125.001MHz to 150.000MHz	45mA Maximum																
Frequency Tolerance/Stability	Inclusive of all conditions: Calibration Tolerance at 25°C, Frequency Stability over the Operating Temperature Range, Supply Voltage Change, Output Load Change, First Year Aging at 25°C, Shock, and Vibration ± 100 ppm, ± 50 ppm, ± 25 ppm, or ± 20 ppm																
Output Voltage Logic High (V_{OH})	90% of V _{DD} Minimum I _{OH} =-8mA																
Output Voltage Logic Low (V_{OL})	10% of V _{DD} Maximum I _{OL} =+8mA																
Rise Time / Fall Time (T_R/T_F)	<table border="0"> <tbody> <tr> <td>20% to 80% of Waveform, 1.544MHz to 24MHz</td> <td>6 nSeconds Maximum</td> </tr> <tr> <td>20% to 80% of Waveform, 24.001MHz to 110MHz</td> <td>4 nSeconds Maximum</td> </tr> <tr> <td>20% to 80% of Waveform, 110.001MHz to 150MHz</td> <td>2 nSeconds Maximum</td> </tr> </tbody> </table>	20% to 80% of Waveform, 1.544MHz to 24MHz	6 nSeconds Maximum	20% to 80% of Waveform, 24.001MHz to 110MHz	4 nSeconds Maximum	20% to 80% of Waveform, 110.001MHz to 150MHz	2 nSeconds Maximum										
20% to 80% of Waveform, 1.544MHz to 24MHz	6 nSeconds Maximum																
20% to 80% of Waveform, 24.001MHz to 110MHz	4 nSeconds Maximum																
20% to 80% of Waveform, 110.001MHz to 150MHz	2 nSeconds Maximum																
Duty Cycle (SYM)	<table border="0"> <tbody> <tr> <td>50% of Waveform</td> <td>50 ± 10(%) (Standard)</td> </tr> <tr> <td>50% of Waveform (at 25°C, at V_{DD}=2.5Vdc over >125MHz)</td> <td>50 ± 5(%) (Optional)</td> </tr> </tbody> </table>	50% of Waveform	50 ± 10 (%) (Standard)	50% of Waveform (at 25°C, at V _{DD} =2.5Vdc over >125MHz)	50 ± 5 (%) (Optional)												
50% of Waveform	50 ± 10 (%) (Standard)																
50% of Waveform (at 25°C, at V _{DD} =2.5Vdc over >125MHz)	50 ± 5 (%) (Optional)																
Load Drive Capability (C_{LOAD})	15pF HCMOS Load Maximum																
Tri-State Input Voltage	<table border="0"> <tbody> <tr> <td>No Connection</td> <td>Enables Output</td> </tr> <tr> <td>V_{IH}: $\geq 90\%$ of V_{DD}</td> <td>Enables Output</td> </tr> <tr> <td>V_{IL}: $\leq 10\%$ of V_{DD}</td> <td>Disables Output: High Impedance</td> </tr> </tbody> </table>	No Connection	Enables Output	V _{IH} : $\geq 90\%$ of V _{DD}	Enables Output	V _{IL} : $\leq 10\%$ of V _{DD}	Disables Output: High Impedance										
No Connection	Enables Output																
V _{IH} : $\geq 90\%$ of V _{DD}	Enables Output																
V _{IL} : $\leq 10\%$ of V _{DD}	Disables Output: High Impedance																
Standby Current	Disabled Output: High Impedance 10 μ A Maximum																
Aging (at 25°C)	± 5 ppm/year Maximum																
Start Up Time (T_S)	10 mSeconds Maximum																
RMS Phase Jitter	12kHz to 20MHz offset frequency 1pSeconds Maximum																

MANUFACTURER
ECLIPTEK CORP.

CATEGORY
OSCILLATOR

SERIES
EC27

PACKAGE
CERAMIC

VOLTAGE
2.5V

CLASS
OS52

REV. DATE
11/06

查询"EC27"供应商

PART NUMBERING GUIDE

EC27 00 ET TS - 30.000M TR

FREQUENCY TOLERANCE / STABILITY

00=±100ppm Maximum (Standard)
 45=±50ppm Maximum, 25=±25ppm Maximum
 20=±20ppm Maximum

OPERATING TEMPERATURE RANGE

Blank=0°C to 70°C (Standard)
 ET=-40°C to 85°C

PACKAGING OPTIONS

Blank=Bulk (Standard)
 TR=Tape and Reel

FREQUENCY

DUTY CYCLE

Blank=50±10%(%) (Standard)
 T=50±5(%)

MECHANICAL DIMENSIONS

ALL DIMENSIONS IN MILLIMETERS

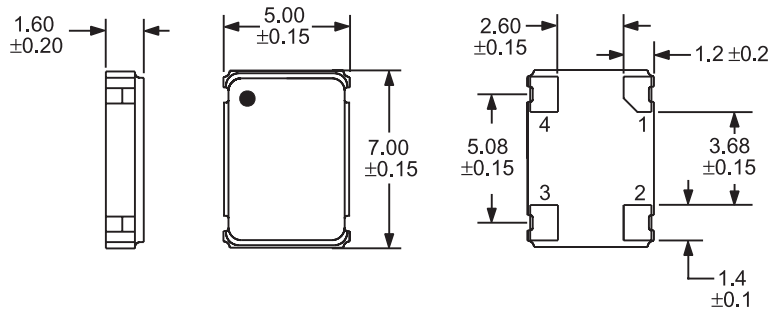

SUGGESTED SOLDER PAD LAYOUT

ALL DIMENSIONS IN MILLIMETERS

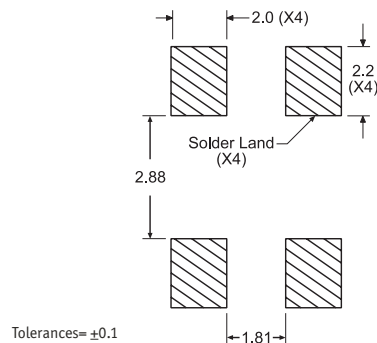

TAPE AND REEL DIMENSIONS

ALL DIMENSIONS IN MILLIMETERS

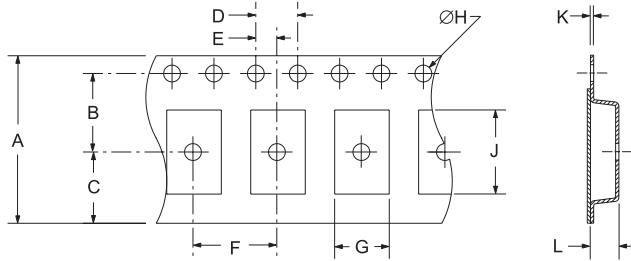

TAPE	A	B	C	D	E
	16±.3-.1	7.5±.1	6.75±.1	4 ±.1	2±.1
F	G	H	J	K	L
8±.1	B0*	1.5 ±.1-0	A0*	.3 ±.05	K0*

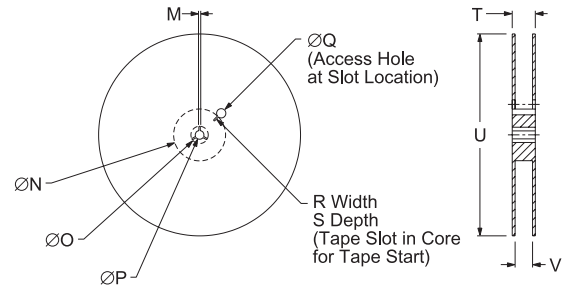

REEL	M	N	O	P	Q
	1.5 MIN	50 MIN	20.2 MIN	13±.2	40 MIN
R	S	T	U	V	QTY/REEL
2.5 MIN	10 MIN	22.4 MAX	360 MAX	16.4±2-0	1,000

*Compliant to EIA 481A

ENVIRONMENTAL/MECHANICAL SPECIFICATIONS

Characteristic

Specification

Fine Leak Test	MIL-STD-883, Method 1014, Condition A
Gross Leak Test	MIL-STD-883, Method 1014, Condition C
Mechanical Shock	MIL-STD-202, Method 213, Condition C
Vibration	MIL-STD-883, Method 2007, Condition A
Solderability	MIL-STD-883, Method 2002
Temperature Cycling	MIL-STD-883, Method 1010
Resistance to Soldering Heat	MIL-STD-202, Method 210
Resistance to Solvents	MIL-STD-202, Method 215

MARKING SPECIFICATIONS

Line 1: ECLIPTEK

Line 2: XX.XXX M

Frequency in MHz (5 Digits Maximum + Decimal)

Line 3: XXY ZZ

Week of Year

Last Digit of Year

Ecliptek Manufacturing Identifier

MANUFACTURER	CATEGORY	SERIES	PACKAGE	VOLTAGE	CLASS	REV. DATE
ECLIPTEK CORP.	OSCILLATOR	EC27	CERAMIC	2.5V	OS52	11/06



Ecliptek MEMS Oscillators

- *Lower Cost, Quicker Delivery Alternative!*

The EMO™ family of oscillators offers exceptional performance, shorter delivery and significant cost advantages by utilizing a revolutionary new MEMS resonator technology. This important innovation enables Ecliptek to offer the ultimate in flexibility with delivery of 2 days for samples and 5 to 10 days for quantities up to 10,000 pieces on tape and reel.

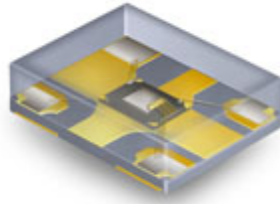

Supply Voltage (V _{DC})	Package Dimensions (all dimensions in millimeters)			
	5 x 7	3.2 x 5	2.5 x 3.2	2 x 2.5
1.8	EMK11	EMK21	EMK31	EMK41
2.5	EMK12	EMK22	EMK32	EMK42
3.3	EMK13	EMK23	EMK33	EMK43

Would you like to request EMO™ samples or a quotation now?

[Click Here](#)

Want to learn more about the Ecliptek EMO™ family of MEMS oscillators?

[Click Here](#)

Product Features:

- Improved frequency stability through the use of a MEMS resonator
- 1.8VDC, 2.5VDC, or 3.3VDC supply voltages
- Frequency range of 1MHz to 125MHz, HCMOS output
- Frequency stability to ±50ppm, -40°C to +85°C operation
- Tri-state or power down functions
- RoHS compliant
- High temperature +260°C reflow capability
- EIA compliant tape and reel packaging
- Four SMD package sizes

If you have any questions or would like additional information regarding the Ecliptek EMO™ family of oscillators, please contact our [Sales Department](#).