



查询"NESG3033M14-T3"供应商

NPN SILICON GERMANIUM RF TRANSISTOR NESG3033M14

NPN SiGe RF TRANSISTOR FOR LOW NOISE, HIGH-GAIN AMPLIFICATION 4-PIN LEAD-LESS MINIMOLD (M14, 1208 PKG)

FEATURES

- The device is an ideal choice for low noise, high-gain amplification
NF = 0.6 dB TYP. @ $V_{CE} = 2\text{ V}$, $I_C = 6\text{ mA}$, $f = 2.0\text{ GHz}$
- Maximum stable power gain: MSG = 20.5 dB TYP. @ $V_{CE} = 2\text{ V}$, $I_C = 15\text{ mA}$, $f = 2.0\text{ GHz}$
- SiGe HBT technology (UHS3) adopted: $f_{max} = 110\text{ GHz}$
- This product is improvement of ESD of NESG3032M14.
- 4-pin lead-less minimold (M14, 1208 PKG)

ORDERING INFORMATION

Part Number	Order Number	Package	Quantity	Supplying Form
NESG3033M14	NESG3033M14-A	4-pin lead-less minimold (M14, 1208 PKG) (Pb-Free)	50 pcs (Non reel)	<ul style="list-style-type: none"> • 8 mm wide embossed taping • Pin 1 (Collector), Pin 4 (Emitter) face the perforation side of the tape
NESG3033M14-T3	NESG3033M14-T3-A		10 kpcs/reel	

Remark To order evaluation samples, contact your nearby sales office.
Unit sample quantity is 50 pcs.

ABSOLUTE MAXIMUM RATINGS ($T_A = +25^\circ\text{C}$)

Parameter	Symbol	Ratings	Unit
Collector to Base Voltage	V_{CBO} ^{Note 1}	5.0	V
Collector to Emitter Voltage	V_{CEO}	4.3	V
Base Current	I_B ^{Note 1}	12	mA
Collector Current	I_C	35	mA
Total Power Dissipation	P_{tot} ^{Note 2}	150	mW
Junction Temperature	T_j	150	$^\circ\text{C}$
Storage Temperature	T_{stg}	-65 to +150	$^\circ\text{C}$

Notes 1. V_{CBO} and I_B are limited by the permissible current of the protection element.

2. Mounted on $1.08\text{ cm}^2 \times 1.0\text{ mm}$ (t) glass epoxy PWB

Caution Observe precautions when handling because these devices are sensitive to electrostatic discharge.

The information in this document is subject to change without notice. Before using this document, please confirm that this is the latest version.

RECOMMENDED OPERATING RANGE (TA = +25°C)

Parameter	Symbol	MIN.	TYP.	MAX.	Unit
Input Power	P _{in}	-	-	0	dBm
Base Feedback Resister	R _b	-	-	100	kΩ

Remark When the voltage return bias circuit like the figure below is used, a current increase is seen because the ESD protection element is turned on when recommended range of motion in the above table is exceeded. However, there is no influence of reliability, including deterioration.

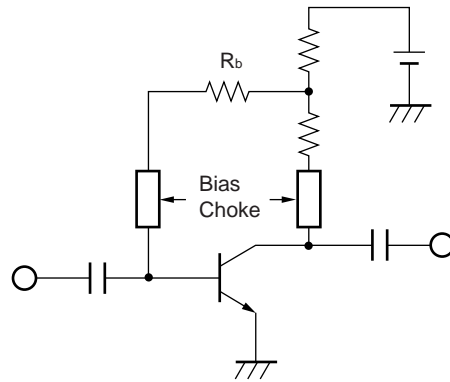

ELECTRICAL CHARACTERISTICS (T_A = +25°C)

Parameter	Symbol	Test Conditions	MIN.	TYP.	MAX.	Unit
DC Characteristics						
Collector Cut-off Current	I _{CBO}	V _{CB} = 5 V, I _E = 0 mA	–	–	100	nA
Emitter Cut-off Current	I _{EBO}	V _{EB} = 1 V, I _C = 0 mA	–	–	100	nA
DC Current Gain	h _{FE} ^{Note 1}	V _{CE} = 2 V, I _C = 6 mA	220	300	380	–
RF Characteristics						
Insertion Power Gain	S _{21e} ²	V _{CE} = 2 V, I _C = 15 mA, f = 2.0 GHz	15.0	17.5	–	dB
Noise Figure	NF	V _{CE} = 2 V, I _C = 6 mA, f = 2.0 GHz, Z _S = Z _{Sopt} , Z _L = Z _{Lopt}	–	0.60	0.85	dB
Associated Gain	G _a	V _{CE} = 2 V, I _C = 6 mA, f = 2.0 GHz, Z _S = Z _{Sopt} , Z _L = Z _{Lopt}	–	17.5	–	dB
Reverse Transfer Capacitance	C _{re} ^{Note 2}	V _{CB} = 2 V, I _E = 0 mA, f = 1 MHz	–	0.15	0.25	pF
Maximum Stable Power Gain	MSG ^{Note 3}	V _{CE} = 2 V, I _C = 15 mA, f = 2.0 GHz	17.5	20.5	–	dB
Gain 1 dB Compression Output Power	P _{O(1 dB)}	V _{CE} = 3 V, I _{C(set)} = 20 mA, f = 2.0 GHz, Z _S = Z _{Sopt} , Z _L = Z _{Lopt}	–	12.5	–	dBm
3rd Order Intermodulation Distortion Output Intercept Point	OIP ₃	V _{CE} = 3 V, I _{C(set)} = 20 mA, f = 2.0 GHz, Z _S = Z _{Sopt} , Z _L = Z _{Lopt}	–	24.0	–	dBm

- Notes 1.** Pulse measurement: PW ≤ 350 μs, Duty Cycle ≤ 2%
2. Collector to base capacitance when the emitter grounded

3. $MSG = \left| \frac{S_{21}}{S_{12}} \right|$

h_{FE} CLASSIFICATION

Rank	FB
Marking	zL
h _{FE} Value	220 to 380

[查询"NESG3033M14-T3"供应商](#)

PACKAGE DIMENSIONS

4-PIN LEAD-LESS MINIMOLD (M14, 1208 PKG) (UNIT: mm)

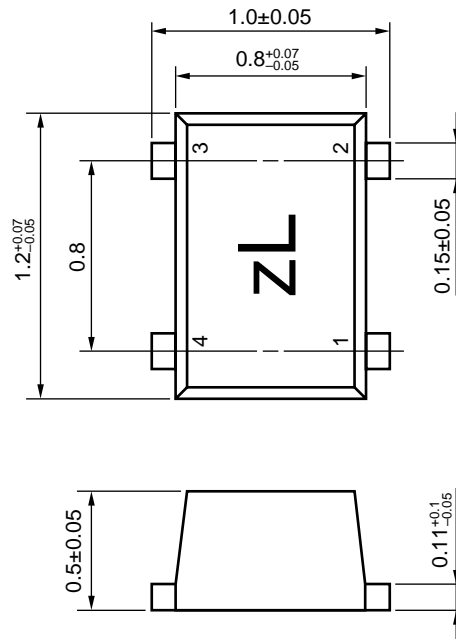

PIN CONNECTIONS

1. Collector
2. Emitter
3. Base
4. NC (Connected with Pin 2)

- **The information in this document is current as of September, 2006. The information is subject to change without notice. For actual design-in, refer to the latest publications of NEC Electronics data sheets or data books, etc., for the most up-to-date specifications of NEC Electronics products. Not all products and/or types are available in every country. Please check with an NEC Electronics sales representative for availability and additional information.**
- No part of this document may be copied or reproduced in any form or by any means without the prior written consent of NEC Electronics. NEC Electronics assumes no responsibility for any errors that may appear in this document.
- NEC Electronics does not assume any liability for infringement of patents, copyrights or other intellectual property rights of third parties by or arising from the use of NEC Electronics products listed in this document or any other liability arising from the use of such products. No license, express, implied or otherwise, is granted under any patents, copyrights or other intellectual property rights of NEC Electronics or others.
- Descriptions of circuits, software and other related information in this document are provided for illustrative purposes in semiconductor product operation and application examples. The incorporation of these circuits, software and information in the design of a customer's equipment shall be done under the full responsibility of the customer. NEC Electronics assumes no responsibility for any losses incurred by customers or third parties arising from the use of these circuits, software and information.
- While NEC Electronics endeavors to enhance the quality, reliability and safety of NEC Electronics products, customers agree and acknowledge that the possibility of defects thereof cannot be eliminated entirely. To minimize risks of damage to property or injury (including death) to persons arising from defects in NEC Electronics products, customers must incorporate sufficient safety measures in their design, such as redundancy, fire-containment and anti-failure features.
- NEC Electronics products are classified into the following three quality grades: "Standard", "Special" and "Specific".

The "Specific" quality grade applies only to NEC Electronics products developed based on a customer-designated "quality assurance program" for a specific application. The recommended applications of an NEC Electronics product depend on its quality grade, as indicated below. Customers must check the quality grade of each NEC Electronics product before using it in a particular application.

"Standard": Computers, office equipment, communications equipment, test and measurement equipment, audio and visual equipment, home electronic appliances, machine tools, personal electronic equipment and industrial robots.

"Special": Transportation equipment (automobiles, trains, ships, etc.), traffic control systems, anti-disaster systems, anti-crime systems, safety equipment and medical equipment (not specifically designed for life support).

"Specific": Aircraft, aerospace equipment, submersible repeaters, nuclear reactor control systems, life support systems and medical equipment for life support, etc.

The quality grade of NEC Electronics products is "Standard" unless otherwise expressly specified in NEC Electronics data sheets or data books, etc. If customers wish to use NEC Electronics products in applications not intended by NEC Electronics, they must contact an NEC Electronics sales representative in advance to determine NEC Electronics' willingness to support a given application.

(Note)

- (1) "NEC Electronics" as used in this statement means NEC Electronics Corporation and also includes its majority-owned subsidiaries.
- (2) "NEC Electronics products" means any product developed or manufactured by or for NEC Electronics (as defined above).

► For further information, please contact

NEC Compound Semiconductor Devices Hong Kong Limited

E-mail: contact@ncsd-hk.necel.com

Hong Kong Head Office TEL: +852-3107-7303 FAX: +852-3107-7309

Taipei Branch Office TEL: +886-2-8712-0478 FAX: +886-2-2545-3859

Korea Branch Office TEL: +82-2-558-2120 FAX: +82-2-558-5209

NEC Electronics (Europe) GmbH <http://www.eu.necel.com/>

TEL: +49-211-6503-0 FAX: +49-211-6503-1327

California Eastern Laboratories, Inc. <http://www.cel.com/>

TEL: +1-408-988-3500 FAX: +1-408-988-0279

Compound Semiconductor Devices Division

NEC Electronics Corporation

URL: <http://www.ncsd.necel.com/>



4590 Patrick Henry Drive
Santa Clara, CA 95054-1817
Telephone: (408) 919-2500
Facsimile: (408) 988-0279

Subject: Compliance with EU Directives

CEL certifies, to its knowledge, that semiconductor and laser products detailed below are compliant with the requirements of European Union (EU) Directive 2002/95/EC Restriction on Use of Hazardous Substances in electrical and electronic equipment (RoHS) and the requirements of EU Directive 2003/11/EC Restriction on Penta and Octa BDE.

CEL Pb-free products have the same base part number with a suffix added. The suffix –A indicates that the device is Pb-free. The –AZ suffix is used to designate devices containing Pb which are exempted from the requirement of RoHS directive (*). In all cases the devices have Pb-free terminals. All devices with these suffixes meet the requirements of the RoHS directive.

This status is based on CEL's understanding of the EU Directives and knowledge of the materials that go into its products as of the date of disclosure of this information.

Restricted Substance per RoHS	Concentration Limit per RoHS (values are not yet fixed)	Concentration contained in CEL devices	
		-A	-AZ
Lead (Pb)	< 1000 PPM	Not Detected	(*)
Mercury	< 1000 PPM	Not Detected	
Cadmium	< 100 PPM	Not Detected	
Hexavalent Chromium	< 1000 PPM	Not Detected	
PBB	< 1000 PPM	Not Detected	
PBDE	< 1000 PPM	Not Detected	

If you should have any additional questions regarding our devices and compliance to environmental standards, please do not hesitate to contact your local representative.

Important Information and Disclaimer: Information provided by CEL on its website or in other communications concerning the substance content of its products represents knowledge and belief as of the date that it is provided. CEL bases its knowledge and belief on information provided by third parties and makes no representation or warranty as to the accuracy of such information. Efforts are underway to better integrate information from third parties. CEL has taken and continues to take reasonable steps to provide representative and accurate information but may not have conducted destructive testing or chemical analysis on incoming materials and chemicals. CEL and CEL suppliers consider certain information to be proprietary, and thus CAS numbers and other limited information may not be available for release.

In no event shall CEL's liability arising out of such information exceed the total purchase price of the CEL part(s) at issue sold by CEL to customer on an annual basis.

See CEL Terms and Conditions for additional clarification of warranties and liability.