

LMK02002

Precision Clock Conditioner with Integrated PLL

General Description

The LMK02002 precision clock conditioner combines the functions of jitter cleaning/reconditioning, multiplication, and distribution of a reference clock. The device integrates a high performance Integer-N Phase Locked Loop (PLL), and four LVPECL clock output distribution blocks.

Each clock distribution block includes a programmable divider, a phase synchronization circuit, a programmable delay, a clock output mux, and an LVPECL output buffer. This allows multiple integer-related and phase-adjusted copies of the reference to be distributed to eight system components.

The clock conditioner comes in a 48-pin LLP package and is footprint compatible with other clocking devices in the same family.

Features

- 20 fs additive jitter
- Integrated Integer-N PLL with outstanding normalized phase noise contribution of -224 dBc/Hz
- Clock output frequency range of 1 to 800 MHz
- 4 LVPECL clock outputs
- Dedicated divider and delay blocks on each clock output
- Pin compatible family of clocking devices
- 3.15 to 3.45 V operation
- Package: 48 pin LLP (7.0 x 7.0 x 0.8 mm)

Target Applications

- Data Converter Clocking
- Networking, SONET/SDH, DSLAM
- Wireless Infrastructure
- Medical
- Test and Measurement
- Military / Aerospace

Functional Block Diagram

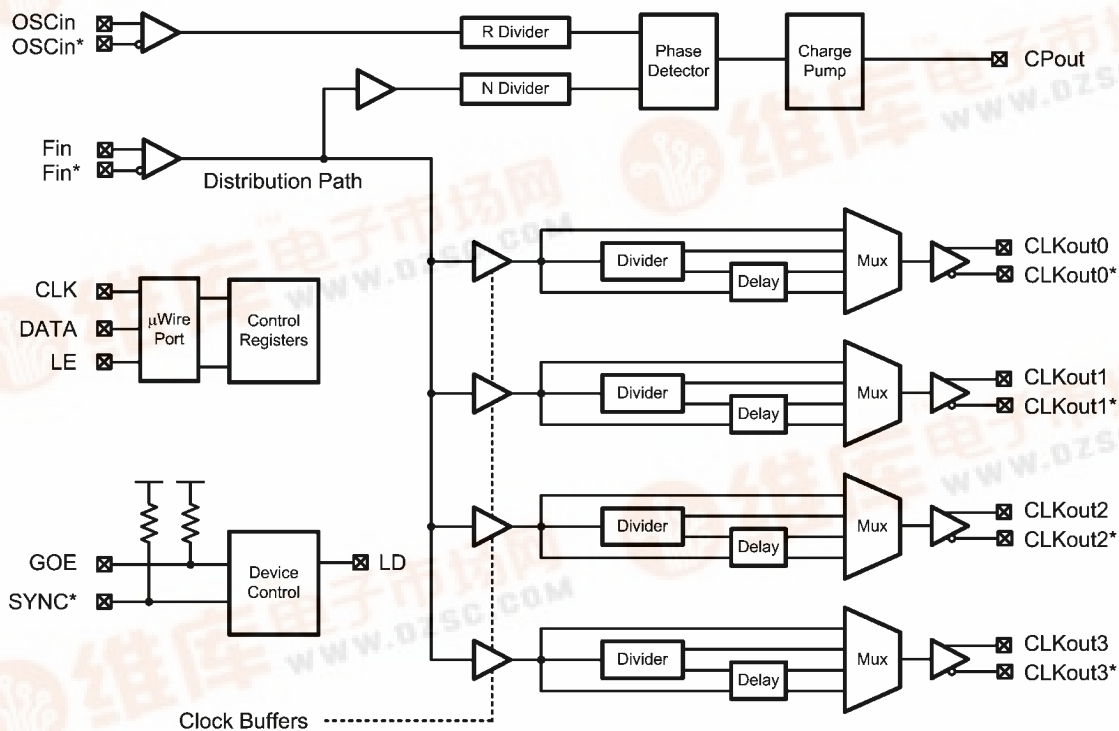

30023301



Connection Diagram

[查询"LMK02002"供应商](#)

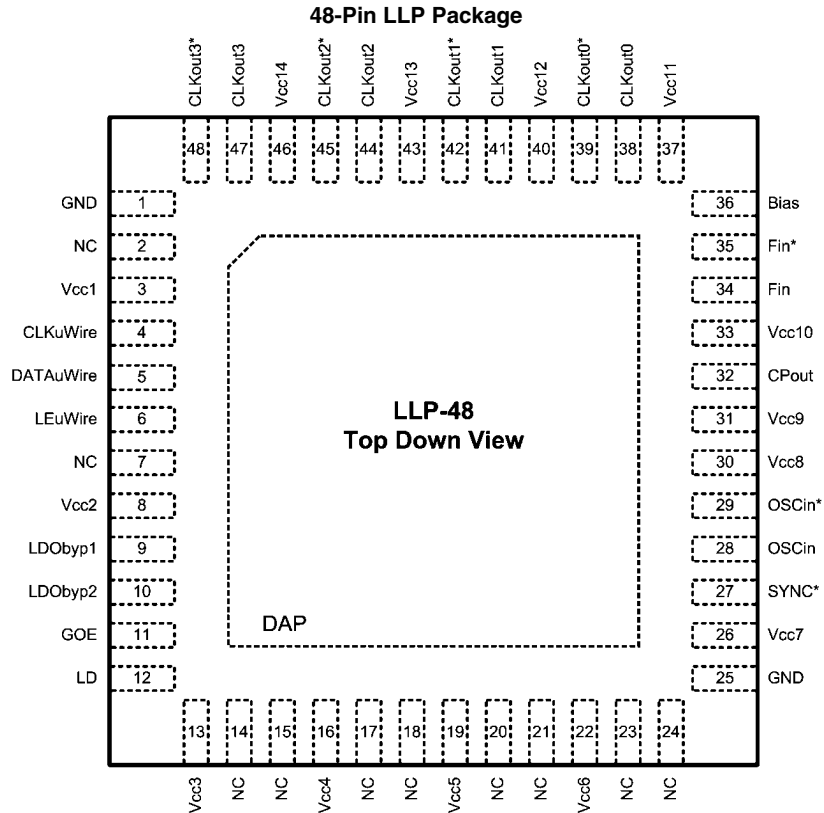

Pin Descriptions

Pin #	Pin Name	I/O	Description
1, 25	GND	-	Ground
2, 7, 14, 15, 17, 18, 20, 21, 23, 24	NC	-	No Connection to these pins
3, 8, 13, 16, 19, 22, 26, 30, 31, 33, 37, 40, 43, 46	Vcc1, Vcc2, Vcc3, Vcc4, Vcc5, Vcc6, Vcc7, Vcc8, Vcc9, Vcc10, Vcc11, Vcc12, Vcc13, Vcc14	-	Power Supply
4	CLKuWire	I	MICROWIRE Clock Input
5	DATAuWire	I	MICROWIRE Data Input
6	LEuWire	I	MICROWIRE Latch Enable Input
9, 10	LDObyp1, LDObyp2	-	LDO Bypass
11	GOE	I	Global Output Enable
12	LD	O	Lock Detect and Test Output
27	SYNC*	I	Global Clock Output Synchronization
28, 29	OSCin, OSCin*	I	Oscillator Clock Input; Must be AC coupled
32	CPout	O	Charge Pump Output
34, 35	Fin, Fin*	I	Frequency Input; Must be AC coupled
36	Bias	I	Bias Bypass
38, 39	CLKout0, CLKout0*	O	LVPECL Clock Output 0
41, 42	CLKout1, CLKout1*	O	LVPECL Clock Output 1
44, 45	CLKout2, CLKout2*	O	LVPECL Clock Output 2
47, 48	CLKout3, CLKout3*	O	LVPECL Clock Output 3
DAP	DAP	-	Die Attach Pad is Ground

Absolute Maximum Ratings (Notes 1, 2)

查询"LMK02002"供应商

If Military/Aerospace specified devices are required, please contact the National Semiconductor Sales Office/ Distributors for availability and specifications.

Parameter	Symbol	Ratings	Units
Power Supply Voltage	V_{CC}	-0.3 to 3.6	V
Input Voltage	V_{IN}	-0.3 to ($V_{CC} + 0.3$)	V
Storage Temperature Range	T_{STG}	-65 to 150	°C
Lead Temperature (solder 4 s)	T_L	+260	°C
Junction Temperature	T_J	125	°C

Recommended Operating Conditions

Parameter	Symbol	Min	Typ	Max	Units
Ambient Temperature	T_A	-40	25	85	°C
Power Supply Voltage	V_{CC}	3.15	3.3	3.45	V

Note 1: "Absolute Maximum Ratings" indicate limits beyond which damage to the device may occur, including inoperability and degradation of device reliability and/or performance. Functional operation of the device and/or non-degradation at the Absolute Maximum Ratings or other conditions beyond those indicated in the Recommended Operating Conditions is not implied. The Recommended Operating Conditions indicate conditions at which the device is functional and the device should not be operated beyond such conditions.

Note 2: This device is a high performance integrated circuit with ESD handling precautions. Handling of this device should only be done at ESD protected work stations. The device is rated to a HBM-ESD of > 2 kV, a MM-ESD of > 200 V, and a CDM-ESD of > 1.2 kV.

Package Thermal Resistance

Package	θ_{JA}	θ_{J-PAD} (Thermal Pad)
48-Lead LLP (Note 3)	27.4° C/W	5.8° C/W

Note 3: Specification assumes 16 thermal vias connect the die attach pad to the embedded copper plane on the 4-layer JEDEC board. These vias play a key role in improving the thermal performance of the LLP. It is recommended that the maximum number of vias be used in the board layout.

Electrical Characteristics (Note 4)

(3.15 V ≤ V_{CC} ≤ 3.45 V, -40 °C ≤ T_A ≤ 85 °C, Differential Inputs/Outputs; except as specified. Typical values represent most likely parametric norms at $V_{CC} = 3.3$ V, $T_A = 25$ °C, and at the Recommended Operation Conditions at the time of product characterization and are not guaranteed).

Symbol	Parameter	Conditions	Min	Typ	Max	Units
Current Consumption						
I_{CC}	Power Supply Current (Note 5)	Entire device; CLKout0 & CLKout3 enabled in Bypass Mode		159		mA
		Entire device; All Outputs Off (no emitter resistors placed)		70		
I_{CC}^{PD}	Power Down Current	POWERDOWN = 1		1		mA
Reference Oscillator						
f_{OSCin}^{square}	Reference Oscillator Input Frequency Range for Square Wave	AC coupled; Differential (V_{OD})	1		200	MHz
V_{OSCin}^{square}	Square Wave Input Voltage for OSCin and OSCin*		0.2		1.6	V _{pp}
Frequency Input						
f_{Fin}	Frequency Input Frequency Range		1		800	MHz
$SLEW_{Fin}$	Frequency Input Slew Rate	(Notes 6, 10)	0.5			V/ns
$DUTY_{Fin}$	Frequency Input Duty Cycle		40		60	%
P_{Fin}	Input Power Range for Fin or Fin*	AC coupled	-13		8	dBm

Symbol	Parameter	Conditions	Min	Typ	Max	Units	
PLL							
f_{COMP}	Phase Detector Frequency				40	MHz	
$I_{SRCECPout}$	Charge Pump Source Current	$V_{CPout} = V_{CC}/2$, PLL_CP_GAIN = 1x		100		μA	
		$V_{CPout} = V_{CC}/2$, PLL_CP_GAIN = 4x		400			
		$V_{CPout} = V_{CC}/2$, PLL_CP_GAIN = 16x		1600			
		$V_{CPout} = V_{CC}/2$, PLL_CP_GAIN = 32x		3200			
$I_{SINKCPout}$	Charge Pump Sink Current	$V_{CPout} = V_{CC}/2$, PLL_CP_GAIN = 1x		-100		μA	
		$V_{CPout} = V_{CC}/2$, PLL_CP_GAIN = 4x		-400			
		$V_{CPout} = V_{CC}/2$, PLL_CP_GAIN = 16x		-1600			
		$V_{CPout} = V_{CC}/2$, PLL_CP_GAIN = 32x		-3200			
$I_{CPoutTRI}$	Charge Pump TRI-STATE [®] Current	$0.5 V < V_{CPout} < V_{CC} - 0.5 V$		2	10	nA	
$I_{CPout\%MIS}$	Magnitude of Charge Pump Sink vs. Source Current Mismatch	$V_{CPout} = V_{CC} / 2$ $T_A = 25^\circ C$		3		%	
$I_{CPoutVTUNE}$	Magnitude of Charge Pump Current vs. Charge Pump Voltage Variation	$0.5 V < V_{CPout} < V_{CC} - 0.5 V$ $T_A = 25^\circ C$		4		%	
$I_{CPoutTEMP}$	Magnitude of Charge Pump Current vs. Temperature Variation			4		%	
PN10kHz	PLL 1/f Noise at 10 kHz Offset (Note 7) Normalized to 1 GHz Output Frequency	PLL_CP_GAIN = 1x		-117		dBc/Hz	
		PLL_CP_GAIN = 32x		-122			
PN1Hz	Normalized Phase Noise Contribution (Note 8)	PLL_CP_GAIN = 1x		-219		dBc/Hz	
		PLL_CP_GAIN = 32x		-224			
Clock Distribution Section (Note 9) - LVPECL Clock Outputs (CLKout0 to CLKout3)							
$Jitter_{ADD}$	Additive RMS Jitter (Note 9)	$R_L = 100 \Omega$ Distribution Path = 800 MHz Bandwidth = 12 kHz to 20 MHz	CLKoutX_MUX = Bypass		20		fs
			CLKoutX_MUX = Divided CLKoutX_DIV = 4		75		
t_{SKEW}	CLKoutX to CLKoutY (Note 10)	Equal loading and identical clock configuration Termination = 50Ω to $V_{CC} - 2 V$	-30	± 3	30	ps	
V_{OH}	Output High Voltage	Termination = 50Ω to $V_{CC} - 2 V$ CLKoutX output frequency = 200 MHz		$V_{CC} - 0.98$		V	
V_{OL}	Output Low Voltage			$V_{CC} - 1.8$		V	
V_{OD}	Differential Output Voltage		660	810	965	mV	
Digital LVTTTL Interfaces (Note 11)							
V_{IH}	High-Level Input Voltage		2.0		V_{CC}	V	
V_{IL}	Low-Level Input Voltage				0.8	V	
I_{IH}	High-Level Input Current	$V_{IH} = V_{CC}$	-5.0		5.0	μA	
I_{IL}	Low-Level Input Current	$V_{IL} = 0$	-40.0		5.0	μA	
V_{OH}	High-Level Output Voltage	$I_{OH} = +500 \mu A$	$V_{CC} - 0.4$			V	
V_{OL}	Low-Level Output Voltage	$I_{OL} = -500 \mu A$			0.4	V	

Symbol	Parameter	Conditions	Min	Typ	Max	Units
查询"LMK02002"供应商 Digital MICROWIRE Interfaces (Note 12)						
V_{IH}	High-Level Input Voltage		1.6		V_{CC}	V
V_{IL}	Low-Level Input Voltage				0.4	V
I_{IH}	High-Level Input Current	$V_{IH} = V_{CC}$	-5.0		5.0	μA
I_{IL}	Low-Level Input Current	$V_{IL} = 0$	-5.0		5.0	μA
MICROWIRE Timing						
t_{CS}	Data to Clock Set Up Time	See Data Input Timing	25			ns
t_{CH}	Data to Clock Hold Time	See Data Input Timing	8			ns
t_{CWH}	Clock Pulse Width High	See Data Input Timing	25			ns
t_{CWL}	Clock Pulse Width Low	See Data Input Timing	25			ns
t_{ES}	Clock to Enable Set Up Time	See Data Input Timing	25			ns
t_{CES}	Enable to Clock Set Up Time	See Data Input Timing	25			ns
t_{EWH}	Enable Pulse Width High	See Data Input Timing	25			ns

Note 4: The Electrical Characteristics tables list guaranteed specifications under the listed Recommended Operating Conditions except as otherwise modified or specified by the Electrical Characteristics Conditions and/or Notes. Typical specifications are estimations only and are not guaranteed.

Note 5: See 3.4 for more current consumption / power dissipation calculation information.

Note 6: For all frequencies the slew rate, $SLEW_{Fin}$, is measured between 20% and 80%.

Note 7: A specification in modeling PLL in-band phase noise is the 1/f flicker noise, $L_{PLL_flicker}(f)$, which is dominant close to the carrier. Flicker noise has a 10 dB/decade slope. PN_{10kHz} is normalized to a 10 kHz offset and a 1 GHz carrier frequency. $PN_{10kHz} = L_{PLL_flicker}(10\text{ kHz}) - 20\log(F_{out} / 1\text{ GHz})$, where $L_{PLL_flicker}(f)$ is the single side band phase noise of only the flicker noise's contribution to total noise, $L(f)$. To measure $L_{PLL_flicker}(f)$ it is important to be on the 10 dB/decade slope close to the carrier. A high phase detector frequency and a clean crystal are important to isolating this noise source from the total phase noise, $L(f)$. $L_{PLL_flicker}(f)$ can be masked by the reference oscillator performance if a low power or noisy source is used. The total PLL inband phase noise performance is the sum of $L_{PLL_flicker}(f)$ and $L_{PLL_flat}(f)$.

Note 8: A specification in modeling PLL in-band phase noise is the Normalized Phase Noise Contribution, $L_{PLL_flat}(f)$, of the PLL and is defined as $PN_{1Hz} = L_{PLL_flat}(f) - 20\log(N) - 10\log(f_{COMP})$. $L_{PLL_flat}(f)$ is the single side band phase noise measured at an offset frequency, f , in a 1 Hz Bandwidth and f_{COMP} is the phase detector frequency of the synthesizer. $L_{PLL_flat}(f)$ contributes to the total noise, $L(f)$. To measure $L_{PLL_flat}(f)$ the offset frequency, f , must be chosen sufficiently smaller than the loop bandwidth of the PLL, and yet large enough to avoid a substantial noise contribution from the reference and flicker noise. $L_{PLL_flat}(f)$ can be masked by the reference oscillator performance if a low power or noisy source is used.

Note 9: The Clock Distribution Section includes all parts of the device except the PLL section. Typical Additive Jitter specifications apply to the clock distribution section only.

Note 10: Specification is guaranteed by characterization and is not tested in production.

Note 11: Applies to GOE, LD, and SYNC*.

Note 12: Applies to CLKuWire, DATAuWire, and LEuWire.

Serial Data Timing Diagram

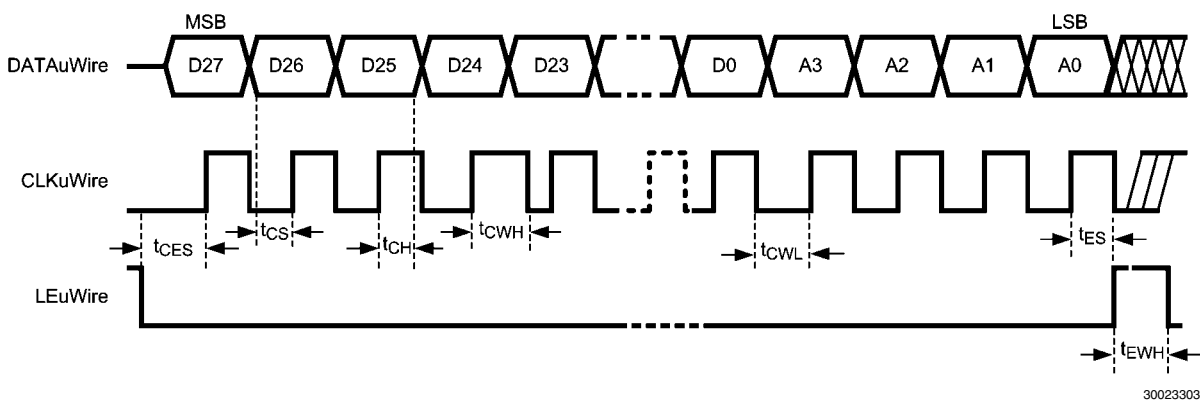

Data bits set on the DATAuWire signal are clocked into a shift register, MSB first, on each rising edge of the CLKuWire signal. On the rising edge of the LEuWire signal, the data is sent from the shift register to the addressed register determined by the LSB bits. After the programming is complete the CLKuWire, DATAuWire, and LEuWire signals should be returned to a low state.

Charge Pump Current Specification Definitions

[查询"LMK02002"供应商](#)

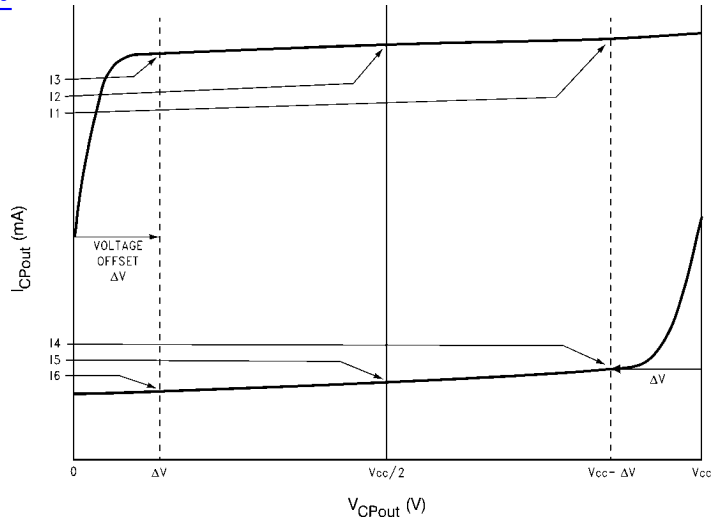

30023331

I1 = Charge Pump Sink Current at $V_{CPout} = V_{cc} - \Delta V$

I2 = Charge Pump Sink Current at $V_{CPout} = V_{cc}/2$

I3 = Charge Pump Sink Current at $V_{CPout} = \Delta V$

I4 = Charge Pump Source Current at $V_{CPout} = V_{cc} - \Delta V$

I5 = Charge Pump Source Current at $V_{CPout} = V_{cc}/2$

I6 = Charge Pump Source Current at $V_{CPout} = \Delta V$

ΔV = Voltage offset from the positive and negative supply rails. Defined to be 0.5 V for this device.

Charge Pump Output Current Magnitude Variation vs. Charge Pump Output Voltage

$$I_{CPout} \text{ Vs } V_{CPout} = \frac{|I1| - |I3|}{|I1| + |I3|} \times 100\%$$

$$= \frac{|I4| - |I6|}{|I4| + |I6|} \times 100\%$$

30023332

Charge Pump Sink Current vs. Charge Pump Output Source Current Mismatch

$$I_{CPout} \text{ Sink Vs } I_{CPout} \text{ Source} = \frac{|I2| - |I5|}{|I2| + |I5|} \times 100\%$$

30023333

Charge Pump Output Current Magnitude Variation vs. Temperature

$$I_{CPout} \text{ Vs } T_A = \frac{|I2|_{T_A} - |I2|_{T_A=25^\circ C}}{|I2|_{T_A=25^\circ C}} \times 100\%$$

$$= \frac{|I5|_{T_A} - |I5|_{T_A=25^\circ C}}{|I5|_{T_A=25^\circ C}} \times 100\%$$

30023334

1.0 Functional Description

The LMK02002 precision clock conditioner combines the functions of jitter cleaning/reconditioning, multiplication, and distribution of a reference clock. The device integrates a high performance Integer-N Phase Locked Loop (PLL), and four LVPECL clock output distribution blocks.

Each clock distribution block includes a programmable divider, a phase synchronization circuit, a programmable delay, a clock output mux, and an LVPECL output buffer. This allows multiple integer-related and phase-adjusted copies of the reference to be distributed to eight system components.

The clock conditioner comes in a 48-pin LLP package and is footprint compatible with other clocking devices in the same family.

1.1 BIAS PIN

To properly use the device, bypass Bias (pin 36) with a low leakage 1 μ F capacitor connected to Vcc. This is important for low noise performance.

1.2 LDO BYPASS

To properly use the device, bypass LDObyp1 (pin 9) with a 10 μ F capacitor and LDObyp2 (pin 10) with a 0.1 μ F capacitor.

1.3 OSCILLATOR INPUT PORT (OSCin, OSCin*)

The purpose of OSCin is to provide the PLL with a reference signal. The OSCin port must be AC coupled, refer to the System Level Diagram in the Application Information section. The OSCin port may be driven single ended by AC grounding OSCin* with a 0.1 μ F capacitor.

1.4 FREQUENCY INPUT PORT (Fin, Fin*)

The purpose of Fin is to provide the PLL with a feedback signal from an external oscillator. The Fin port may be driven single ended by AC grounding Fin*.

1.5 CLKout DELAYS

Each individual clock output includes a delay adjustment. Clock output delay registers (CLKoutX_DLY) support a 150 ps step size and range from 0 to 2250 ps of total delay.

1.6 LVPECL OUTPUTS

Each LVPECL output may be disabled individually by programming the CLKoutX_EN bits. All the outputs may be disabled simultaneously by pulling the GOE pin low or programming EN_CLKout_Global to 0.

1.7 GLOBAL CLOCK OUTPUT SYNCHRONIZATION

The SYNC* pin synchronizes the clock outputs. When the SYNC* pin is held in a logic low state, the divided outputs are also held in a logic low state. When the SYNC* pin goes high, the divided clock outputs are activated and will transition to a high state simultaneously. Clocks in the bypassed state are not affected by SYNC* and are always synchronized with the divided outputs.

The SYNC* pin must be held low for greater than one clock cycle of the Frequency Input port, also known as the distribution path. Once this low event has been registered, the outputs will not reflect the low state for four more cycles. Similarly once the SYNC* pin becomes high, the outputs will not simultaneously transition high until four more distribution path clock cycles have passed. See the timing diagram below for

further detail. In the timing diagram below the clocks are programmed as CLKout0_MUX = Bypassed, CLKout1_MUX = Divided, CLKout1_DIV = 2, CLKout2_MUX = Divided, and CLKout2_DIV = 4.

SYNC* Timing Diagram

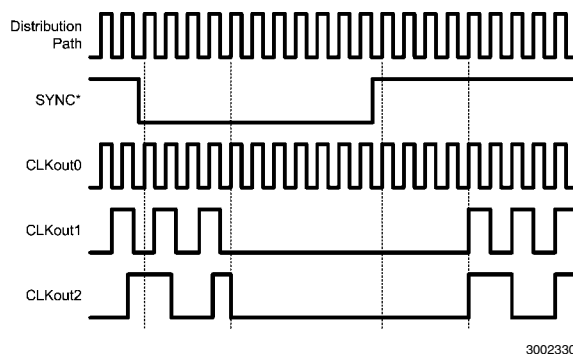

30023304

The SYNC* pin provides an internal pull-up resistor as shown on the functional block diagram. If the SYNC* pin is not terminated externally the clock outputs will operate normally. If the SYNC* function is not used, clock output synchronization is not guaranteed.

1.8 CLKout OUTPUT STATES

Each clock output may be individually enabled with the CLKoutX_EN bits. Each individual output enable control bit is gated with the Global Output Enable input pin (GOE) and the Global Output Enable bit (EN_CLKout_Global).

All clock outputs can be disabled simultaneously if the GOE pin is pulled low by an external signal or EN_CLKout_Global is set to 0.

CLKoutX_EN bit	EN_CLKout_Global bit	GOE pin	Clock X Output State
1	1	Low	Low
Don't care	0	Don't care	Off
0	Don't care	Don't care	Off
1	1	High / No Connect	Enabled

When an LVPECL output is in the Off state, the outputs are at a voltage of approximately 1 volt.

1.9 GLOBAL OUTPUT ENABLE AND LOCK DETECT

The GOE pin provides an internal pull-up resistor. If it is not terminated externally, the clock output states are determined by the Clock Output Enable bits (CLKoutX_EN) and the EN_CLKout_Global bit.

By programming the PLL_MUX register to Digital Lock Detect Active High (See 2.5.2), the Lock Detect (LD) pin can be connected to the GOE pin in which case all outputs are set low automatically if the synthesizer is not locked.

1.10 POWER ON RESET

When supply voltage to the device increases monotonically from ground to Vcc, the power on reset circuit sets all registers to their default values, see 2.3.1 for more information on default register values. Voltage should be applied to all Vcc pins simultaneously.

2.0 General Programming Information

[查询"LMK02002"供应商](#)

The LMK02002 device is programmed using several 32-bit registers which control the device's operation. The registers consist of a data field and an address field. The last 4 register bits, ADDR[3:0] form the address field. The remaining 28 bits form the data field DATA[27:0].

During programming, LEuWire is low and serial data is clocked in on the rising edge of clock (MSB first). When LEuWire goes high, data is transferred to the register bank selected by the address field. Only registers R0 to R7, R11, R14, and R15 need to be programmed for proper device operation.

It is required to program register R14.

2.1 RECOMMENDED PROGRAMMING SEQUENCE

The recommended programming sequence involves programming R0 with the reset bit set (RESET = 1) to ensure the device is in a default state. It is not necessary to program R0 again. Registers are programmed in order with R15 being the last register programmed. An example programming sequence is shown below.

- Program R0 with the reset bit set (RESET = 1). This ensures the device is in a default state.
- Program R4 to R7 as necessary with desired clocks with appropriate enable, mux, divider, and delay settings.
- Program R11 with DIV4 setting if necessary.
- Program R14 with global clock output bit, power down setting, PLL mux setting, and PLL R divider. It is required to program register R14.
 - R14 must be programmed in accordance with the register map as shown in the register map (see 2.2).
- Program R15 with PLL charge pump gain, and PLL N divider.

2.2 LMK02002 REGISTER MAP

Register	31	30	29	28	27	26	25	24	23	22	21	20	19	18	17	16	15	14	13	12	11	10	9	8	7	6	5	4	3	2	1	0
	Data [27:0]																	A3			A2		A1		A0							
R0	RESET	0	0	0	0	0	0	0	0	0	0	0	0	0	0	0	0	0	0	0	0	0	0	0	0	0	0	0	0	0	0	
R4	0	0	0	0	0	0	0	0	0	0	0	0	0	0	CLKout0_MUX [1:0]	0	0	0	0	0	0	0	0	0	0	0	0	0	0	0	0	
R5	0	0	0	0	0	0	0	0	0	0	0	0	0	0	CLKout1_MUX [1:0]	0	0	0	0	0	0	0	0	0	0	0	0	0	0	0	0	
R6	0	0	0	0	0	0	0	0	0	0	0	0	0	0	CLKout2_MUX [1:0]	0	0	0	0	0	0	0	0	0	0	0	0	0	0	0	0	
R7	0	0	0	0	0	0	0	0	0	0	0	0	0	0	CLKout3_MUX [1:0]	0	0	0	0	0	0	0	0	0	0	0	0	0	0	0	0	
R11	0	0	0	0	0	0	0	0	0	0	0	0	0	0	1	0	0	0	0	0	0	0	0	0	0	0	0	0	0	0	0	
R14	0	0	1	0	0	0	0	0	0	0	0	0	0	0	0	0	0	0	0	0	0	0	0	0	0	0	0	0	0	0	0	
R15	PLL_CP_GAIN [1:0]	0	0	0	0	0	0	0	0	0	0	0	0	0	0	0	0	0	0	0	0	0	0	0	0	0	0	0	0	0	0	
				POWERDOWN	EN_CLKout_Global	TRI-STATE	PLL_CP_POL	PLL_MUX [3:0]										PLL_R [11:0]														

2.3 REGISTER R4 to R7

Registers R4 through R7 control the eight clock outputs. Register R4 controls CLKout0, Register R5 controls CLKout1, and so on. There is one additional bit in register R0 called RESET. Aside from this, the functions of these bits are identical. The X in CLKoutX_MUX, CLKoutX_DIV, CLKoutX_DLY, and CLKoutX_EN denote the actual clock output which may be from 0 to 3.

2.3.1 RESET bit -- R0 only

This bit is only in register R0. The use of this bit is optional and it should be set to '0' if not used. Setting this bit to a '1' forces all registers to their power on reset condition and therefore automatically clears this bit. If this bit is set, all other R0 bits are ignored and R0 needs to be programmed again if used with its proper values and RESET = 0.

Bit Name	Default Bit Value	Bit State	Bit Description	Register	Bit Location
RESET	0	No reset, normal operation	Reset to power on defaults	R0	31
CLKoutX_MUX	0	Bypassed	CLKoutX mux mode	R4 to R7	18:17
CLKoutX_EN	0	Disabled	CLKoutX enable		16
CLKoutX_DIV	1	Divide by 2	CLKoutX clock divide		15:8
CLKoutX_DLY	0	0 ps	CLKoutX clock delay		7:4
DIV4	0	PDF ≤ 20 MHz	Phase Detector Frequency	R11	15
EN_CLKout_Global	1	Normal - CLKouts normal	Global clock output enable	R14	27
POWERDOWN	0	Normal - Device active	Device power down		26
PLL_CP_TRI	0	Normal - PLL active	TRI-STATE PLL charge pump		25
PLL_CP_POL	0	Negative Polarity CP	Polarity of charge pump		24
PLL_MUX	0	Disabled	Multiplexer control for LD pin	R19	23:20
PLL_R	10	R divider = 10	PLL R divide value		19:8
PLL_CP_GAIN	0	100 uA	Charge pump current	R15	31:30
PLL_N	760	N divider = 760	PLL N divide value		25:8

2.3.2 CLKoutX_MUX[1:0] -- Clock Output Multiplexers

These bits control the Clock Output Multiplexer for each clock output. Changing between the different modes changes the

blocks in the signal path and therefore incurs a delay relative to the bypass mode. The different MUX modes and associated delays are listed below.

CLKoutX_MUX [1:0]	Mode	Added Delay Relative to Bypass Mode
0	Bypassed (default)	0 ps
1	Divided	100 ps
2	Delayed	400 ps (In addition to the programmed delay)
3	Divided and Delayed	500 ps (In addition to the programmed delay)

2.3.3 CLKoutX_DIV[7:0] -- Clock Output Dividers

These bits control the clock output divider value. In order for these dividers to be active, the respective CLKoutX_MUX (See 2.3.2) bit must be set to either "Divided" or "Divided and Delayed" mode. After all the dividers are programmed, the SYNC* pin must be used to ensure that all edges of the clock outputs are aligned (See 1.7). The Clock Output Dividers follow the VCO Divider so the final clock divide for an output is VCO Divider × Clock Output Divider. By adding the divider block to the output path a fixed delay of approximately 100 ps is incurred.

The actual Clock Output Divide value is twice the binary value programmed as listed in the table below.

CLKoutX_DIV[7:0]								Clock Output Divider value
0	0	0	0	0	0	0	0	Invalid
0	0	0	0	0	0	0	1	2 (default)
0	0	0	0	0	0	1	0	4
0	0	0	0	0	0	1	1	6
0	0	0	0	0	1	0	0	8
0	0	0	0	0	1	0	1	10
.
1	1	1	1	1	1	1	1	510

2.3.4 CLKoutX_DLY[3:0] -- Clock Output Delays

These bits control the delay stages for each clock output. In order for these delays to be active, the respective CLKoutX_MUX (See 2.3.2) bit must be set to either "Delayed" or "Divided and Delayed" mode. By adding the delay block to the output path a fixed delay of approximately 400 ps is incurred in addition to the delay shown in the table below.

CLKoutX_DLY[3:0]	Delay (ps)
0	0 (default)
1	150
2	300
3	450
4	600
5	750
6	900
7	1050
8	1200

CLKoutX_DLY[3:0]	Delay (ps)
查询"LMK02002"供应商	1350
10	1500
11	1650
12	1800
13	1950
14	2100
15	2250

2.3.5 CLKoutX_EN bit -- Clock Output Enables

These bits control whether an individual clock output is enabled or not. If the EN_CLKout_Global bit (See 2.5.4) is set to zero or if GOE pin is held low, all CLKoutX_EN bit states will be ignored and all clock outputs will be disabled. See 1.8 for more information on CLKout states.

CLKoutX_EN bit	Conditions	CLKoutX State
0	EN_CLKout_Global bit = 1	Disabled (default)
1	GOE pin = High / No Connect 1	Enabled

2.4 REGISTER R11

This register only has one bit and only needs to be programmed in the case that the phase detector frequency is greater than 20 MHz and digital lock detect is used. Otherwise, it is automatically defaulted to the correct values.

2.4.1 DIV4

This bit divides the frequency presented to the digital lock detect circuitry by 4. It is necessary to get a reliable output from the digital lock detect output in the case of a phase detector frequency greater than 20 MHz.

DIV4	Digital Lock Detect Circuitry Mode
0	Not divided; Phase detector frequency \leq 20 MHz (default)
1	Divided by 4; Phase detector frequency $>$ 20 MHz

2.5 REGISTER R14

The LMK02002 requires register R14 to be programmed as shown in the register map (see 2.2).

2.5.1 PLL_R[11:0] -- R Divider Value

These bits program the PLL R Divider and are programmed in binary fashion.

PLL_R[11:0]											PLL R Divide Value	
0	0	0	0	0	0	0	0	0	0	0	0	Invalid
0	0	0	0	0	0	0	0	0	0	0	1	1
0	0	0	0	0	0	0	0	0	0	1	0	2
.
0	0	0	0	0	0	0	0	1	0	1	0	10 (default)
.
1	1	1	1	1	1	1	1	1	1	1	1	4095

2.5.2 PLL_MUX[3:0] -- Multiplexer Control for LD Pin

These bits set the output mode of the LD pin. The table below lists several different modes.

PLL_MUX[3:0]	Output Type	LD Pin Function
0	Hi-Z	Disabled (default)
1	Push-Pull	Logic High
2	Push-Pull	Logic Low
3	Push-Pull	Digital Lock Detect (Active High)
4	Push-Pull	Digital Lock Detect (Active Low)
5	Push-Pull	Analog Lock Detect
6	Open Drain NMOS	Analog Lock Detect
7	Open Drain PMOS	Analog Lock Detect
8	Invalid	
9	Push-Pull	N Divider Output/2 (50% Duty Cycle)
10	Invalid	
11	Push-Pull	R Divider Output/2 (50% Duty Cycle)
12 to 15	Invalid	

2.5.3 POWERDOWN bit -- Device Power Down

This bit can power down the device. Enabling this bit powers down the entire device and all blocks, regardless of the state of any of the other bits or pins.

POWERDOWN bit	Mode
0	Normal Operation (default)
1	Entire Device Powered Down

2.5.4 EN_CLKout_Global bit -- Global Clock Output Enable

This bit overrides the individual CLKoutX_EN bits (See 2.3.5). When this bit is set to 0, all clock outputs are disabled, regardless of the state of any of the other bits or pins. See 1.8 for more information on CLKout states.

EN_CLKout_Global bit	Clock Outputs
0	All Off
1	Normal Operation (default)

2.5.5 PLL_CP_TRI bit -- PLL Charge Pump TRI-STATE

This bit sets the PLL charge pump TRI-STATE.

PLL_CP_TRI	PLL Charge Pump
0	Normal operation (default)
1	TRI-STATE

2.5.6 PLL_CP_POL bit -- PLL Charge Pump Polarity

This bit sets the polarity of the charge pump to either negative or positive. A negative charge pump is used with a VCO or VCXO which decreases frequency with increasing tuning voltage. A positive charge pump is used with a VCO or VCXO which increases frequency with increasing tuning voltage.

PLL_CP_POL	PLL Charge Pump Polarity
0	Negative (default)
1	Positive

[查询"LMK02002"供应商](#)

2.6 Register R15

2.6.1 PLL_N[17:0] PLL N Divider

These bits program the divide value for the PLL N Divider. The PLL N Divider follows the VCO Divider and precedes the PLL phase detector. Since the VCO Divider is also in the feedback path from the VCO to the PLL Phase Detector, the total N divide value, N_{Total} , is also influenced by the VCO Divider value. $N_{Total} = PLL\ N\ Divider \times VCO\ Divider$. The VCO frequency is calculated as, $f_{VCO} = f_{OSCin} \times PLL\ N\ Divider \times VCO\ Divider / PLL\ R\ Divider$. Since the PLL N divider is a pure binary counter, there are no illegal divide values for PLL_N [17:0] except for 0.

PLL_N[17:0]	PLL N Divider Value
0 0 0 0 0 0 0 0 0 0 0 0 0 0 0 0 0 0	Invalid
0 0 0 0 0 0 0 0 0 0 0 0 0 0 0 0 0 1	1
.
0 0 0 0 0 0 0 0 1 0 1 1 1 1 1 0 0 0	760 (default)
.
1 1 1 1 1 1 1 1 1 1 1 1 1 1 1 1 1 1	262143

2.6.2 PLL_CP_GAIN[1:0] -- PLL Charge Pump Gain

These bits set the charge pump gain of the PLL.

PLL_CP_GAIN[1:0]	Charge Pump Gain
0	1x (default)
1	4x
2	16x
3	32x

3.0 Application Information

[查询"LMK02002"供应商](#)

3.1 SYSTEM LEVEL DIAGRAM

The following shows the LMK02002 in a typical application. In this setup the clock may be multiplied, reconditioned, and redistributed.

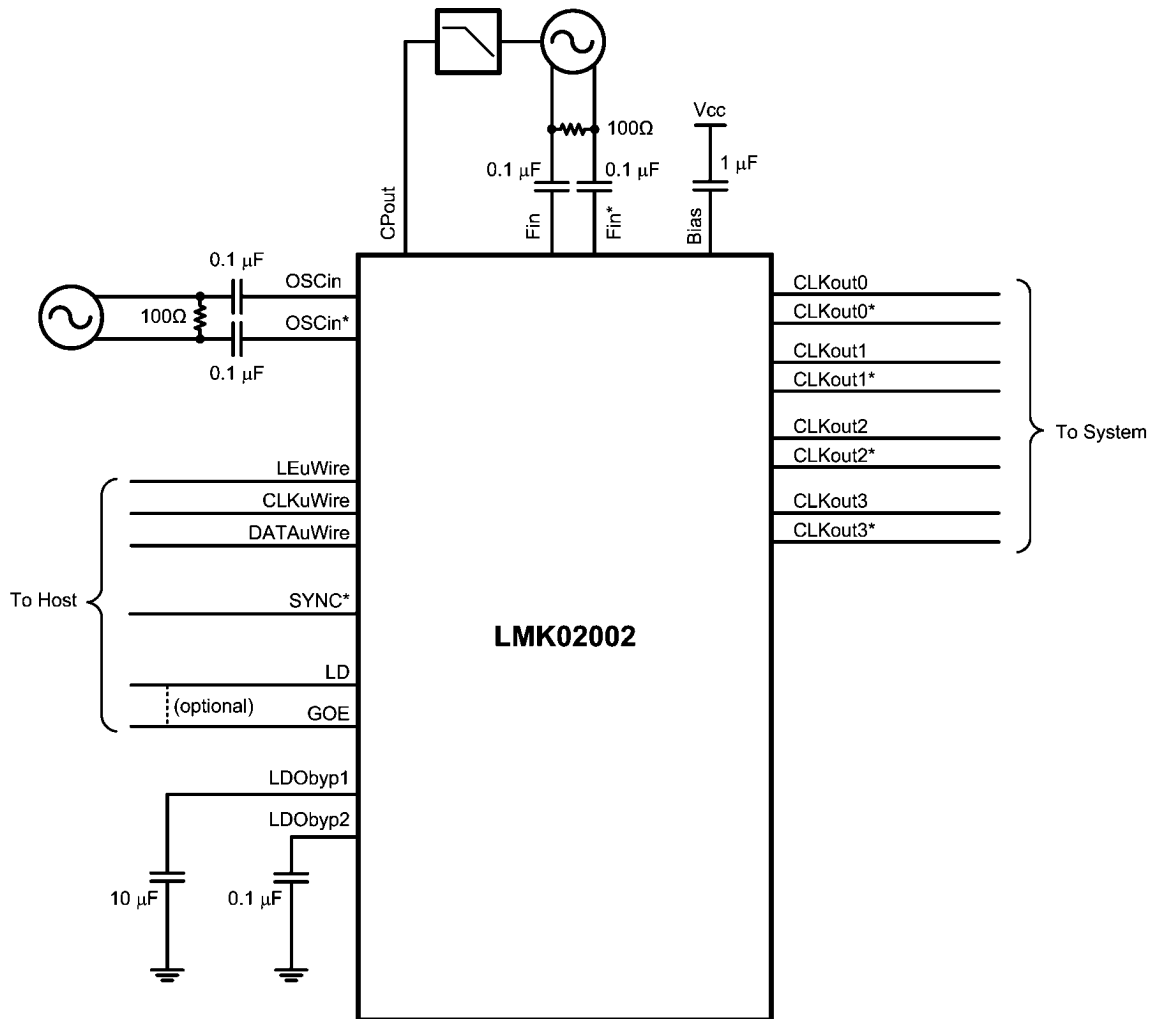

30023370

FIGURE 1. Typical Application

3.2 BIAS PIN

To properly use the device, bypass Bias (pin 36) with a low leakage 1 μ F capacitor connected to Vcc. This is important for low noise performance.

3.3 LDO BYPASS

To properly use the device, bypass LDObyp1 (pin 9) with a 10 μ F capacitor and LDObyp2 (pin 10) with a 0.1 μ F capacitor.

3.4 CURRENT CONSUMPTION / POWER DISSIPATION

Calculations

Due to the myriad of possible configurations the following table serves to provide enough information to allow the user to

calculate estimated current consumption of the LMK02002. Unless otherwise noted $V_{CC} = 3.3\text{ V}$, $T_A = 25\text{ }^\circ\text{C}$.

Table 3.4 - Block Current Consumption

Block	Condition	Current Consumption at 3.3 V (mA)	Power Dissipated in device (mW)	Power Dissipated in LVPECL emitter resistors (mW)
Entire device, core current	All outputs off; No LVPECL emitter resistors connected	70	231	-
Clock buffers (internal)	The low clock buffer is enabled anytime one of CLKout0 through CLKout3 are enabled	9	29.7	-
Output buffers	LVPECL output, bypass mode (includes 120 Ω emitter resistors)	40	72	60
	LVPECL output, disabled mode (includes 120 Ω emitter resistors)	17.4	38.3	19.1
	LVPECL output, disabled mode. No emitter resistors placed; open outputs	0	0	-
Divide circuitry per output	Divide enabled, divide = 2	5.3	17.5	-
	Divide enabled, divide > 2	8.5	28.0	-
Delay circuitry per output	Delay enabled, delay < 8	5.8	19.1	-
	Delay enabled, delay > 7	9.9	32.7	-
Entire device	CLKout0 & CLKout3 enabled in bypass mode	159	404.7	120

From Table 3.4 the current consumption can be calculated in any configuration. For example, the current for the entire device with two LVPECL (CLKout0 and CLKout3) outputs in bypass mode can be calculated by adding up the following blocks: core current, clock buffers, and two LVPECL output buffer currents. There will also be two LVPECL outputs drawing emitter current, but some of the power from the current draw is dissipated in the external 120 Ω resistors which doesn't add to the power dissipation budget for the device. If delays or divides are switched in, then the additional current for these stages needs to be added as well.

For power dissipated by the device, the total current entering the device is multiplied by the voltage at the device minus the power dissipated in any emitter resistors connected to any of the LVPECL outputs. If no emitter resistors are connected to the LVPECL outputs, this power will be 0 watts. For example, in the case of two LVPECL (CLKout0 and CLKout3) operating at 3.3 volts, we calculate $3.3\text{ V} \times (70 + 9 + 40 + 40)\text{ mA} = 3.3\text{ V} \times 159\text{ mA} = 524.7\text{ mW}$. Because the LVPECL outputs have emitter resistors hooked up and the power dissipated by these resistors is 60 mW for each clock, the total device power dissipation is $524.7\text{ mW} - 120\text{ mW} = 404.7\text{ mW}$.

When an LVPECL output is active, $\sim 1.9\text{ V}$ is the average voltage on each output as calculated from the LVPECL V_{OH} &

V_{OL} typical specification. Therefore the power dissipated in each emitter resistor is approximately $(1.9\text{ V})^2 / 120\ \Omega = 30\text{ mW}$. When an LVPECL output is disabled, the emitter resistor voltage is $\sim 1.07\text{ V}$. Therefore the power dissipated in each emitter resistor is approximately $(1.07\text{ V})^2 / 120\ \Omega = 9.5\text{ mW}$.

3.5 THERMAL MANAGEMENT

Power consumption of the LMK02002 can be high enough to require attention to thermal management. For reliability and performance reasons the die temperature should be limited to a maximum of 125 $^\circ\text{C}$. That is, as an estimate, T_A (ambient temperature) plus device power consumption times θ_{JA} should not exceed 125 $^\circ\text{C}$.

The package of the device has an exposed pad that provides the primary heat removal path as well as excellent electrical grounding to the printed circuit board. To maximize the removal of heat from the package a thermal land pattern including multiple vias to a ground plane must be incorporated on the PCB within the footprint of the package. The exposed pad must be soldered down to ensure adequate heat conduction out of the package. A recommended land and via pattern is shown in *Figure 2*. More information on soldering LLP packages can be obtained at www.national.com.

[查询"LMK02002"供应商](#)

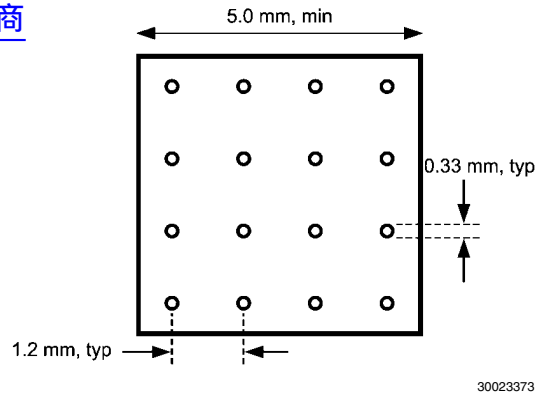
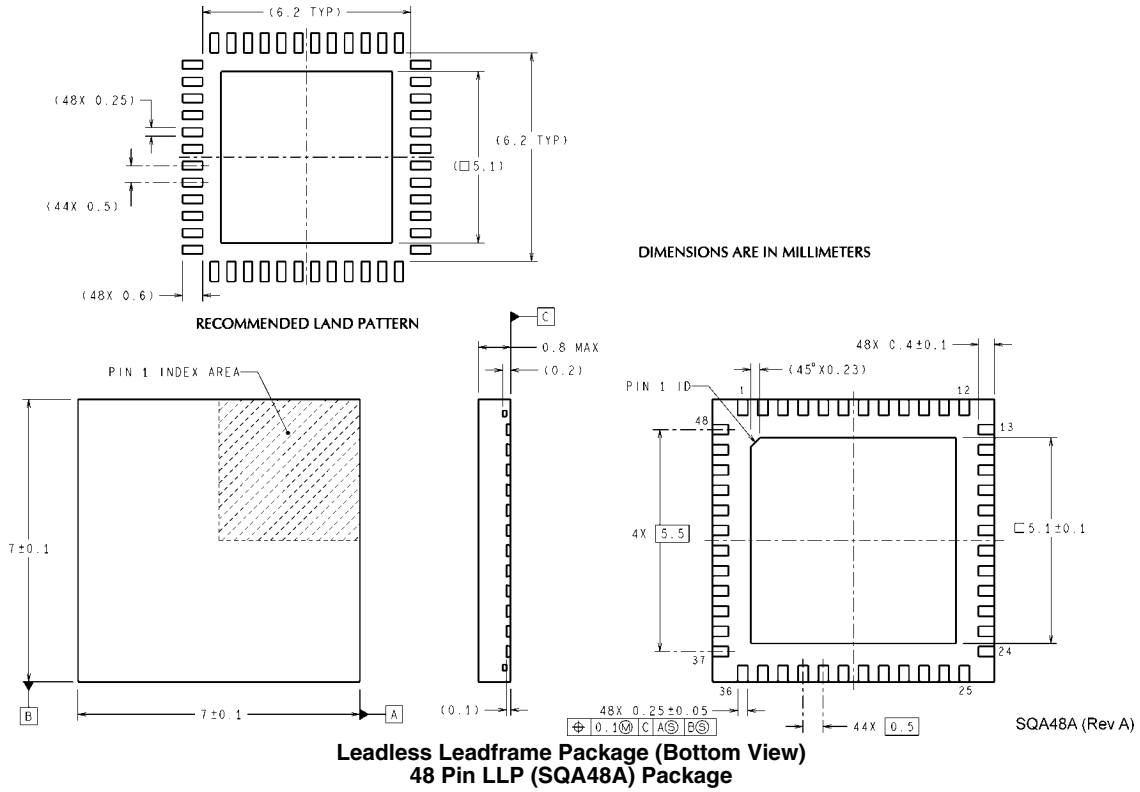

FIGURE 2.

To minimize junction temperature it is recommended that a simple heat sink be built into the PCB (if the ground plane layer is not exposed). This is done by including a copper area of about 2 square inches on the opposite side of the PCB from the device. This copper area may be plated or solder coated to prevent corrosion but should not have conformal coating (if

possible), which could provide thermal insulation. The vias shown in *Figure 2* should connect these top and bottom copper layers and to the ground layer. These vias act as “heat pipes” to carry the thermal energy away from the device side of the board to where it can be more effectively dissipated.

Physical Dimensions inches (millimeters) unless otherwise noted
[查询"LMK02002"供应商](#)



Order Number	Package Marking	Packing	LVPECL Outputs
LMK02002ISQ	K02002 I	250 Unit Tape and Reel	4
LMK02002ISQX	K02002 I	2500 Unit Tape and Reel	4

Notes

[查询"LMK02002"供应商](#)

[查询"LMK02002"供应商](#)

Notes

THE CONTENTS OF THIS DOCUMENT ARE PROVIDED IN CONNECTION WITH NATIONAL SEMICONDUCTOR CORPORATION ("NATIONAL") PRODUCTS. NATIONAL MAKES NO REPRESENTATIONS OR WARRANTIES WITH RESPECT TO THE ACCURACY OR COMPLETENESS OF THE CONTENTS OF THIS PUBLICATION AND RESERVES THE RIGHT TO MAKE CHANGES TO SPECIFICATIONS AND PRODUCT DESCRIPTIONS AT ANY TIME WITHOUT NOTICE. NO LICENSE, WHETHER EXPRESS, IMPLIED, ARISING BY ESTOPPEL OR OTHERWISE, TO ANY INTELLECTUAL PROPERTY RIGHTS IS GRANTED BY THIS DOCUMENT.

TESTING AND OTHER QUALITY CONTROLS ARE USED TO THE EXTENT NATIONAL DEEMS NECESSARY TO SUPPORT NATIONAL'S PRODUCT WARRANTY. EXCEPT WHERE MANDATED BY GOVERNMENT REQUIREMENTS, TESTING OF ALL PARAMETERS OF EACH PRODUCT IS NOT NECESSARILY PERFORMED. NATIONAL ASSUMES NO LIABILITY FOR APPLICATIONS ASSISTANCE OR BUYER PRODUCT DESIGN. BUYERS ARE RESPONSIBLE FOR THEIR PRODUCTS AND APPLICATIONS USING NATIONAL COMPONENTS. PRIOR TO USING OR DISTRIBUTING ANY PRODUCTS THAT INCLUDE NATIONAL COMPONENTS, BUYERS SHOULD PROVIDE ADEQUATE DESIGN, TESTING AND OPERATING SAFEGUARDS.

EXCEPT AS PROVIDED IN NATIONAL'S TERMS AND CONDITIONS OF SALE FOR SUCH PRODUCTS, NATIONAL ASSUMES NO LIABILITY WHATSOEVER, AND NATIONAL DISCLAIMS ANY EXPRESS OR IMPLIED WARRANTY RELATING TO THE SALE AND/OR USE OF NATIONAL PRODUCTS INCLUDING LIABILITY OR WARRANTIES RELATING TO FITNESS FOR A PARTICULAR PURPOSE, MERCHANTABILITY, OR INFRINGEMENT OF ANY PATENT, COPYRIGHT OR OTHER INTELLECTUAL PROPERTY RIGHT.

LIFE SUPPORT POLICY

NATIONAL'S PRODUCTS ARE NOT AUTHORIZED FOR USE AS CRITICAL COMPONENTS IN LIFE SUPPORT DEVICES OR SYSTEMS WITHOUT THE EXPRESS PRIOR WRITTEN APPROVAL OF THE CHIEF EXECUTIVE OFFICER AND GENERAL COUNSEL OF NATIONAL SEMICONDUCTOR CORPORATION. As used herein:

Life support devices or systems are devices which (a) are intended for surgical implant into the body, or (b) support or sustain life and whose failure to perform when properly used in accordance with instructions for use provided in the labeling can be reasonably expected to result in a significant injury to the user. A critical component is any component in a life support device or system whose failure to perform can be reasonably expected to cause the failure of the life support device or system or to affect its safety or effectiveness.

National Semiconductor and the National Semiconductor logo are registered trademarks of National Semiconductor Corporation. All other brand or product names may be trademarks or registered trademarks of their respective holders.

Copyright© 2007 National Semiconductor Corporation

For the most current product information visit us at www.national.com



**National Semiconductor
Americas Customer
Support Center**
Email:
new.feedback@nsc.com
Tel: 1-800-272-9959

**National Semiconductor Europe
Customer Support Center**
Fax: +49 (0) 180-530-85-86
Email: europe.support@nsc.com
Deutsch Tel: +49 (0) 69 9508 6208
English Tel: +49 (0) 870 24 0 2171
Français Tel: +33 (0) 1 41 91 8790

**National Semiconductor Asia
Pacific Customer Support Center**
Email: ap.support@nsc.com

**National Semiconductor Japan
Customer Support Center**
Fax: 81-3-5639-7507
Email: jpn.feedback@nsc.com
Tel: 81-3-5639-7560