

EM78M611E

**Universal Serial Bus
Series Microcontroller**

**Product
Specification**

DOC. VERSION 1.1

ELAN MICROELECTRONICS CORP.

November 2006



Trademark Acknowledgments:

IBM is a registered trademark and PS/2 is a trademark of IBM.

Windows is a trademark of Microsoft Corporation.

ELAN and ELAN logo  are trademarks of ELAN Microelectronics Corporation.

Copyright © 2006 by ELAN Microelectronics Corporation

All Rights Reserved

Printed in Taiwan

The contents of this specification are subject to change without further notice. ELAN Microelectronics assumes no responsibility concerning the accuracy, adequacy, or completeness of this specification. ELAN Microelectronics makes no commitment to update, or to keep current the information and material contained in this specification. Such information and material may change to conform to each confirmed order.

In no event shall ELAN Microelectronics be made responsible for any claims attributed to errors, omissions, or other inaccuracies in the information or material contained in this specification. ELAN Microelectronics shall not be liable for direct, indirect, special incidental, or consequential damages arising from the use of such information or material.

The software (if any) described in this specification is furnished under a license or nondisclosure agreement, and may be used or copied only in accordance with the terms of such agreement.

ELAN Microelectronics products are not intended for use in life support appliances, devices, or systems. Use of ELAN Microelectronics product in such applications is not supported and is prohibited.

NO PART OF THIS SPECIFICATION MAY BE REPRODUCED OR TRANSMITTED IN ANY FORM OR BY ANY MEANS WITHOUT THE EXPRESSED WRITTEN PERMISSION OF ELAN MICROELECTRONICS.



ELAN MICROELECTRONICS CORPORATION

Headquarters:

No. 12, Innovation Road 1
Hsinchu Science Park
Hsinchu, TAIWAN 30077
Tel: +886 3 563-9977
Fax: +886 3 563-9966
<http://www.emc.com.tw>

Hong Kong:

Elan (HK) Microelectronics Corporation, Ltd.
Flat A, 19F., World Tech Centre
95 How Ming Street, Kwun Tong
Kowloon, HONG KONG
Tel: +852 2723-3376
Fax: +852 2723-7780
elanhk@emc.com.hk

USA:

Elan Information Technology Group (U.S.A.)
1821 Saratoga Ave., Suite 250
Saratoga, CA 95070
U.S.A.
Tel: +1 408 366-8225
Fax: +1 408 366-8220

Europe:

Elan Microelectronics Corp. (Europe)
Siewerdstrasse 105
8050 Zurich, SWITZERLAND
Tel: +41 43 299-4060
Fax: +41 43 299-4079
<http://www.elan-europe.com>

Shenzhen:

Elan Microelectronics Shenzhen, Ltd.
SSMEC Bldg., 3F, Gaoxin S. Ave.
Shenzhen Hi-Tech Industrial Park
Shenzhen, Guangdong, CHINA
Tel: +86 755 2601-0565
Fax: +86 755 2601-0500

Shanghai:

Elan Microelectronics Shanghai, Ltd.
23/Bldg. #115 Lane 572, Bibo Road
Zhangjiang Hi-Tech Park
Shanghai, CHINA
Tel: +86 21 5080-3866
Fax: +86 21 5080-4600



Contents

1	General Description	1
2	Features	1
3	Type Definition.....	3
4	Application.....	3
5	Pin Assignment	4
6	Pin Description.....	6
7	Block Diagram	7
8	Function Description.....	8
8.1	Program Memory	8
8.2	Data Memory	9
8.2.1	Special Purpose Register	9
8.2.2	Operation Registers	10
8.2.2.1	R0 (Indirect Addressing Register)	10
8.2.2.2	R1 (Timer / Clock Counter)	10
8.2.2.3	R2 (Program Counter & Stack)	10
8.2.2.4	R3 (Status Register)	11
8.2.2.5	R4 (RAM Select Register)	13
8.2.2.6	R5 (Port 5 I/O Register).....	13
8.2.2.7	R6 (Port 6 I/O Register).....	13
8.2.2.8	R7 (Port 7 I/O Register).....	13
8.2.2.9	R8 (Port 8 I/O Register).....	13
8.2.2.10	R9 (Port 9 I/O Register).....	13
8.2.2.11	RA (EEPROM Control Register).....	14
8.2.2.12	RB (Pattern Detect Application Control Register)	14
8.2.2.13	RC (USB Application Status Register)	14
8.2.2.12	RD (USB Application FIFO Address Register)	15
8.2.2.13	RE (USB Application FIFO Data Register).....	15
8.2.2.14	RF (Interrupt Status Register)	15
8.2.3	Control Registers.....	16
8.2.3.1	A (Accumulator).....	16
8.2.3.2	CONT (Control Register).....	17
8.2.3.3	IOC5 ~IOC9 I/O (Port Direction Control Registers)	18
8.2.3.4	IOCA (Operation Mode Control Register)	18
8.2.3.5	IOCB (Port 9 Wake-up Pin Select Register)	19
8.2.3.7	IOCD (Port 9 Pull High Control Register).....	19
8.2.3.8	IOCE (Special Function Control Register).....	20
8.2.3.9	IOCF (Interrupt Mask Register).....	21



8.3	Extra Control Register.....	21
8.4	USB Application FIFOs	21
8.5	USB Application	22
8.5.1	USB Device Controller	22
8.5.2	Device Address and Endpoints	23
8.6	Reset	23
8.6.1	Power-on Reset.....	23
8.6.2	Watchdog Reset.....	23
8.6.3	USB Reset.....	23
8.7	Saving Power Mode.....	23
8.7.1	Power Down Mode.....	23
8.7.2	Dual Clock Mode	24
8.8	Interrupt	24
8.9	Pattern Detect Application (PDA)	25
8.9.1	Function Description.....	25
8.9.2	Control Register	26
8.9.3	Sampling Rate and Debounce Length	26
8.10	Pulse Width Modulation (PWM)	28
8.10.1	Function Description.....	28
8.10.2	Duty Cycle	28
8.10.3	Control Register	28
8.11	Analog-To-Digital Converter (ADC)	29
8.11.1	Function Description.....	29
8.11.2	Control Register	29
8.12	EEPROM.....	31
9	Absolute Maximum Ratings.....	32
10	DC Electrical Characteristic.....	32
11	Application Circuit.....	34

APPENDIX

A	Special Register Map	35
B	Instruction Set	37
C	Code option Register	39

Specification Revision History

Doc. Version	Revision Description	Date
1.0	Preliminary version	2006/04/17
1.1	Released version	2006/11/24

1 General Description

The EM78611E is a series of 8-bit Universal Serial Bus RISC architecture microcontroller, Multi-Time Programming (MTP) microcontrollers. It is specifically designed for USB low speed device application and to support standard devices such as PS/2 keyboard. The EM78611E also supports one device address and three endpoints. With no firmware involved, these series of microcontrollers can automatically identify and decode Standard USB Command to Endpoint Zero.

The EM78611E has eight-level stacks and six interrupt sources. It has 144 bytes of general purpose SRAM, 6K bytes of program ROM, and an embedded 4 bytes of E²PROM.

These series of ICs have many powerful features, including:

- Dual clock mode which allows the device to run on low power saving frequency.
- Pattern Detect Application function which is used in a serial transmission to count waveform width.
- Pause Width Modulation that can generate a duty-cycle-programmable signal.
- 24-channel AD converter with up to 10 bits resolution.

2 Features

- Operating voltage: 4.4V ~ 5.5V
- Low-cost solution for low-speed USB devices, such as keyboard, joystick, and Gamepad
- USB Specification Compliance
 - Universal Serial Bus Specification Version 1.1
 - USB Device Class Definition for Human Interface Device (HID), Firmware Specification Version 1.1
 - Supports one device address and three endpoints
- USB Application
 - P75 (D-) has an internal pull-high resistor (1.5 K Ω)
 - USB protocol handling
 - USB device state handling
 - Identifying and decoding of Standard USB commands to EndPoint Zero
- PS/2 Application Support
 - Built-in PS/2 port interface for keyboard and mouse



- Built-in 8-bit RISC MCU
 - 8-level stacks for subroutine nesting and interrupt
 - 8-bit real time clock/counter (TCC) with overflow interrupt
 - Six available interrupts
 - Built-in RC oscillator free running for Watchdog Timer and Dual clock mode
 - Two independent programmable prescalers for WDT and TCC
 - Two power saving methods:
 1. Power-down mode (Sleep mode)
 2. Dual clock mode
 - Two clocks per instruction cycle
 - Multi-time programmable
- I/O Ports
 - Up to 11 LED sink pins
 - Each GPIO pin of Ports 5, 6, 8, P90~P93, P95 and P96; has an internal programmable pull-high resistor (25K Ω)
 - Each GPIO pin of Port 6, P74 ~ P77 and Port 9 can wake up the MCU from sleep mode by input state change
- Internal Memory
 - Built-in 6K \times 13 bits Program ROM
 - Built-in 144 bytes general purpose registers (SRAM)
 - Built-in USB Application FIFOs
 - Built-in 4 bytes EEPROM with a minimum of 4K write/erase cycles
- Operation Frequency
 - Normal Mode: MCU runs with an external oscillator frequency of 6 MHz or 12 MHz
 - Dual Clock Mode: MCU runs at a frequency of 256kHz (or 32 kHz, 4kHz, 500Hz), emitted by the internal oscillator with the external ceramic resonator turned off to save power.
- Built-in Pattern Detect Application for serial signal transmission
- Built-in Pulse Width Modulation (PWM)
 - Up to 2 channels PWM function on P92 (PWM1) and P93 (PWM2)
 - Up to 8-bit resolution PWM output
 - Up to 8 selections of duty cycles



- Built-in 24-Channel Analog-to-Digital Converter (ADC)
 - Up to 24 channels
 - Up to 10 bits resolution
 - 4 ADC conversion rates: 256K/128K/64K/32K
- Built-in 3.3V Voltage Regulator
 - For MCU power supply
 - Pull-up source for the external USB resistor on D-pin
- Package Type:
 - 40-pin PDIP (600mil) (EM78M611EXAP)
 - 44-pin QFP (10×10mm, footprint=3.2mm) (EM78M611EXAQ)
 - 20-pin PDIP (300mil)/SOP (300mil) (EM78M611EXBP/BM)
 - 20-pin SSOP (209mil) (EM78M611EXDM)
 - 24-pin PDIP (600mil)/SOP (300mil) (EM78M611EXCP/CM)
 - 24-pin SSOP (150mil) (EM78M611EXEM)

3 Type Definition

The EM78M611E series has six types of packaging. Each type is divided into two modules, namely; original, and with both E²PROM and A/D Converter. Hence, packaging configuration for each series is defined. Table 3.1 below summarizes which series of the EM78M611E belong to which module.

Table 3-1 Packaging Summary of EM78M611E Series IC

Original	With Both
EM78M611EA**	EM78M611ED**

4 Application

- USB Keyboard only
- USB and PS/2 both compatible with Keyboard
- USB Keyboard with USB Mouse
- USB Joystick

5 Pin Assignment

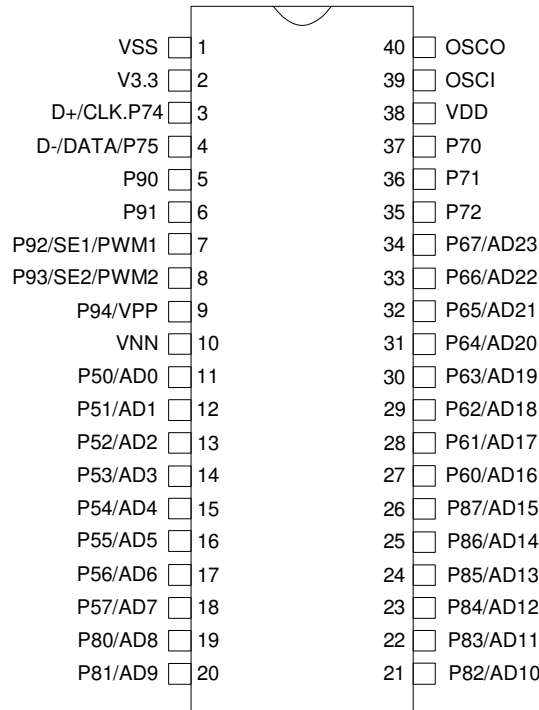

Fig. 3-1 EM78M611EXAP (40-Pin DIP)

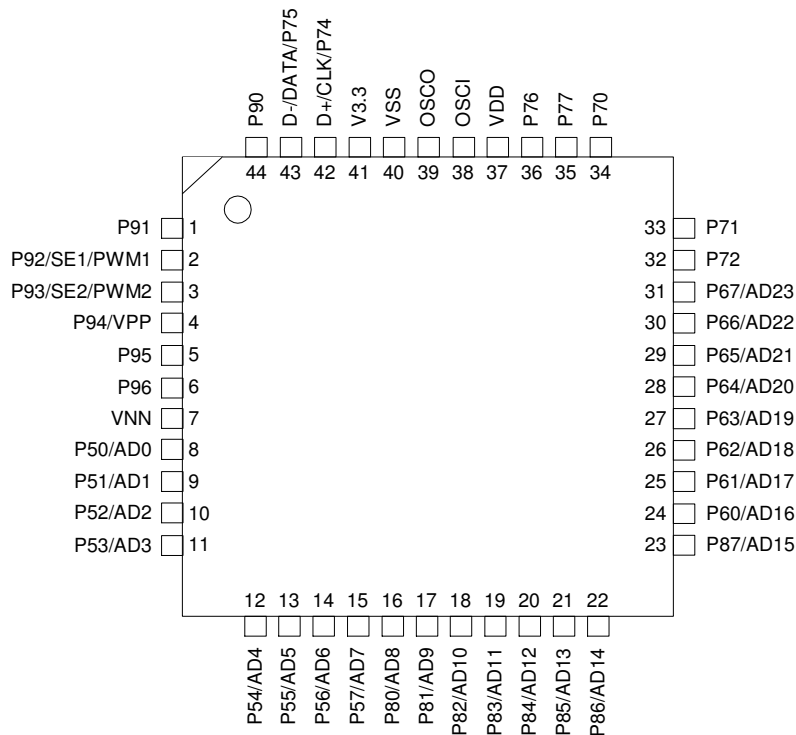

Fig. 3-2 EM78M611EXAQ (44-Pin QFP)

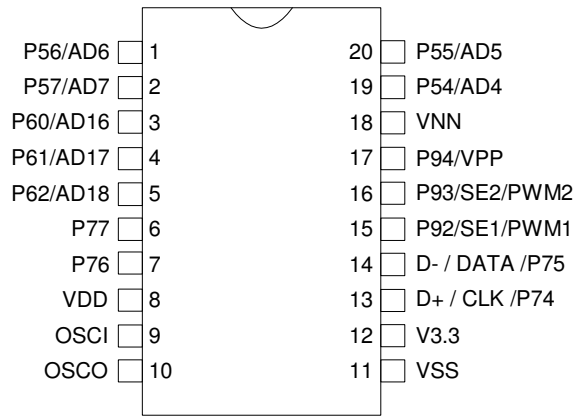

Fig. 3-3 EM78M611EXBP/BM/DM (20-Pin DIP/SOP/SSOP)

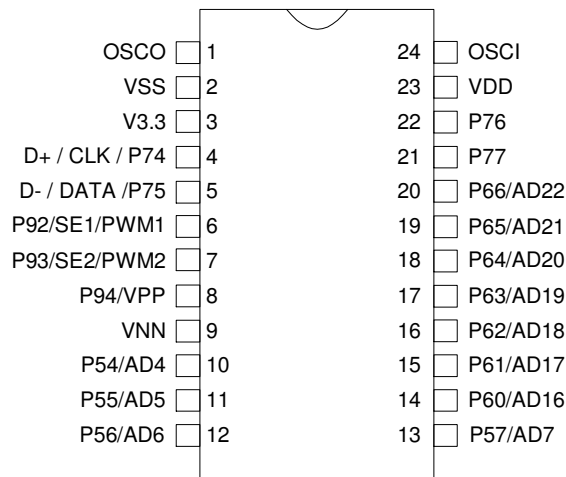

Fig. 3-4 EM78M611EXCP/CM/EM (24-Pin DIP/SOP/SSOP)



6 Pin Description

Symbol	I/O	Function
P50 ~ P57	I/O	General 8-bit bidirectional input/output port. All pins on this port can be internally pulled-high by software control.
P60 ~ P67	I/O	General 8-bit bidirectional input/output port. All pins on this port can be internally pulled-high by software control.
P70 ~ P72 P76 ~ P77	I/O	LED sink pins P76 ~ P77 will have an internally pulled-high resistor when the EM78M611E is running in PS/2 mode.
P80 ~ P87	I/O	General 8-bit bidirectional input/output port. All pins on this port can be internally pulled-high by software control.
P90 ~ P93 P95 ~ P96	I/O	General 6-bit bidirectional input/output port. All pins on this port can be internally pulled-high by software control or LED sink pins.
P94 / Vpp	I	Input only. MTP program pin.
PWM1 PWM2	O	PWM output pins.
D+/CLK/P74	I/O	USB plus data line interface or CLK for PS/2 keyboard. When the EM78M611E is running in PS/2 mode, this pin will have an internal pulled-high resistor (2.2K Ω), with VDD=5.0V.
D-/DATA/P75	I/O	USB minus data line interface or DATA for PS/2 keyboard. When the EM78M611E is running in PS/2 mode, this pin will have an internal pulled-high resistor (2.2K Ω), with V _{3.3} =3.3V. When the EM78M611E is running in USB mode, this pin will have an internal pulled-high resistor (1.5K Ω), with VDD=3.3V.
OSCI	I	6MHz / 12MHz ceramic resonator input.
OSCO	O	Return path for 6MHz / 12MHz ceramic resonator.
VNN	-	MTP program pin. Used in programming the on-chip ROM. During normal operation, this pin is connected to Ground.
V3.3	PWR	3.3V regulator output
VDD	PWR	Power supply pin
GND	PWR	Ground pin



7 Block Diagram

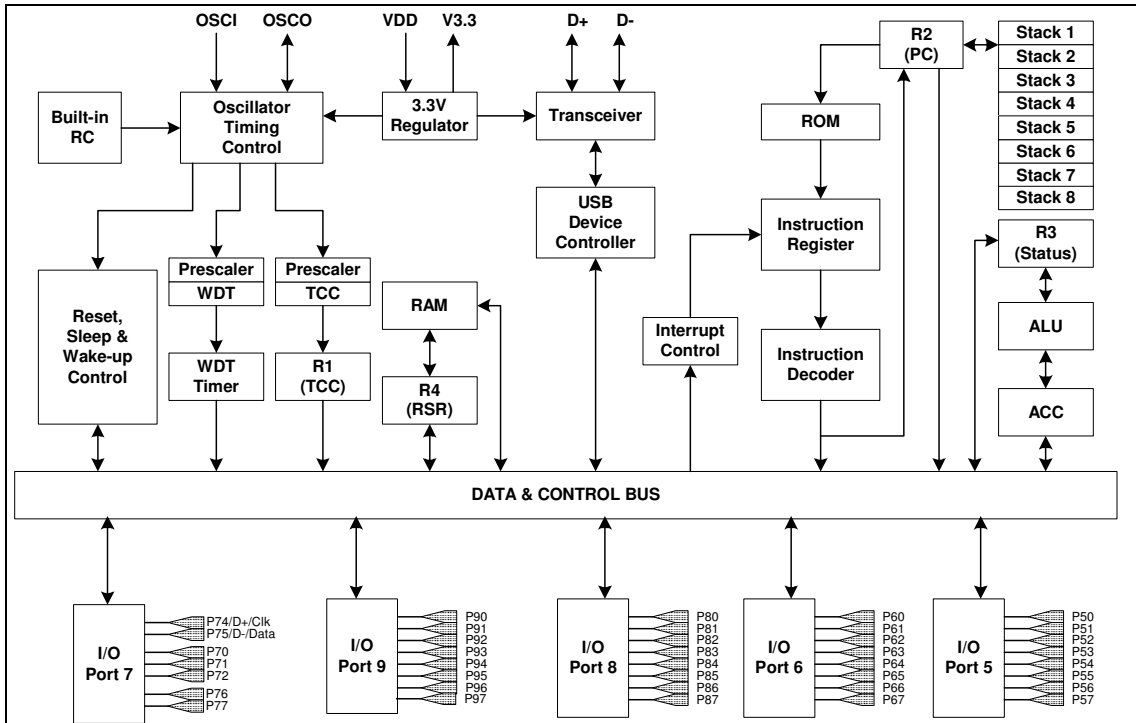



8 Function Description

The EM78M611E memory is organized into three spaces, namely; User Program memory in 6K×13 bits ROM space, Data Memory in 144 bytes SRAM space, EEPROM space and USB Application FIFOs for EndPoint0, EndPoint1, and EndPoint2. Furthermore, several registers are used for special purposes.

8.1 Program Memory

The program space of the EM78M611E is 6K words, and is divided into six pages. Each page is 1K words long. After a reset, the 13-bit Program Counter (PC) points to location zero of the program space.

The Interrupt Vector is at 0x0001 and accommodates TCC interrupt, RF1 (SE1) timing counter interrupt, RF2 (SE2) timing counter interrupt, P74~P77 State Changed interrupt, EndPoint0 interrupt, USB Suspend interrupt, USB Reset interrupt, and USB Host Resume interrupt.

After an interrupt, the MCU will fetch the next instruction from the corresponding address as illustrated in the following diagram.

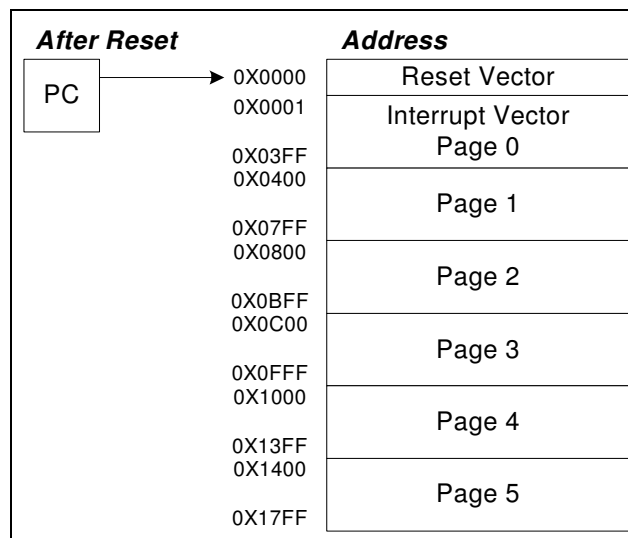

8.2 Data Memory

The Data Memory has 144 bytes SRAM space. It has also an on-chip USB Application FIFO space for USB Application. Figure 8-1 (next page) shows the organization of the Data Memory Space.

8.2.1 Special Purpose Register

When the microcontroller executes instructions, specific registers are implemented to ensure proper operation of essential functions such as Status Register which records the calculation status, Port I/O Control Registers which control the I/O pins' direction, etc. Lots of other special purpose registers are provided for various functions.

Note that Special Control Registers can only be read or written to by two instructions: IOR and IOW.

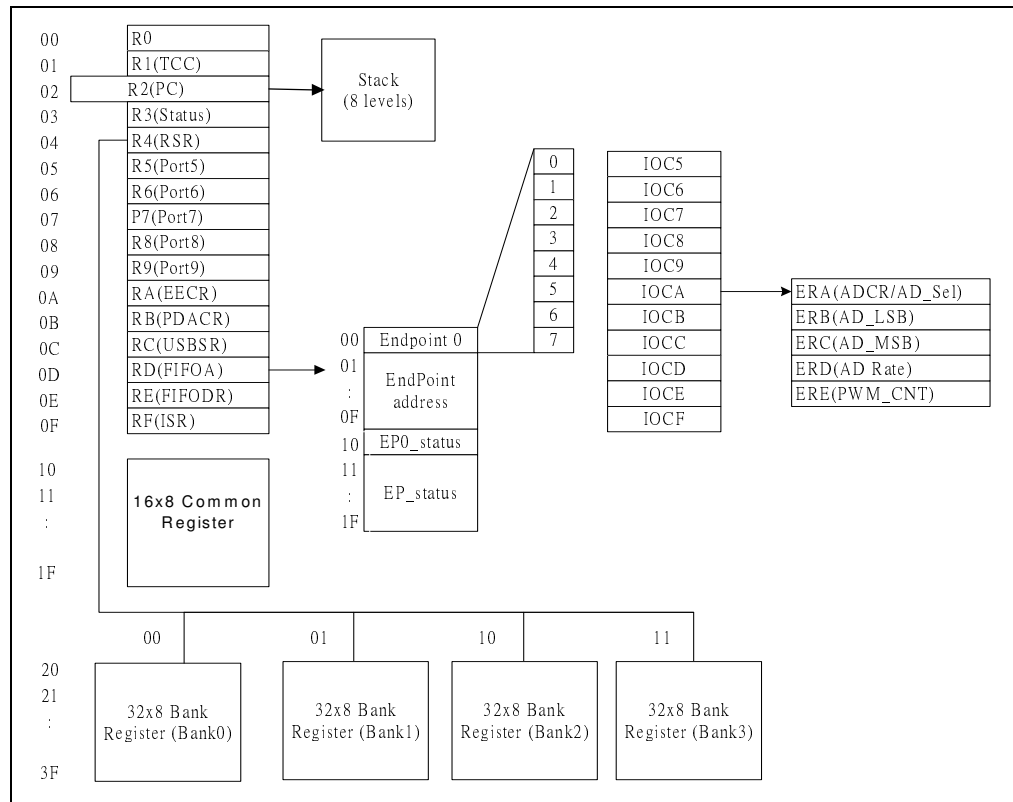

Fig. 8-1 Data RAM Organization of EM78M611E



8.2.2 Operation Registers

The following subsections describe each of the Operation Registers of the Special Purpose Registers. The Operation Registers are arranged according to the order of the registers' address. Note that some registers are read only, while others are both readable and writable.

8.2.2.1 R0 (Indirect Addressing Register) *Default Value: (0B_0000_0000)*

R0 is not a physically implemented register. Its major function is as an indirect addressing pointer. Any instruction using R0 as a pointer actually accesses data pointed by the RAM Select Register (R4).

8.2.2.2 R1 (Timer / Clock Counter) *Default Value: (0B_0000_0000)*

The TCC register is an 8-bit timer or counter. It is readable and writable as any other register. The Timer module will be incremented after execution of every instruction cycles. User can work around this by writing an adjusted value. The Timer interrupt is generated when the R1 register overflows from FFh to 00h. This overflow sets bit TCIF (RF[0]). The interrupt can be masked by clearing bit TCIE (IOCF[0]). After Power-on reset and Watchdog reset, the initial value of this register is 0x00.

8.2.2.3 R2 (Program Counter & Stack) *Default Value: (0B_0000_0000)*

The EM78M611E Program Counter is a 13-bit register that allows accessing of the 6k words of the Program Memory with 8 level stacks. The eight LSB bits, A0~A7, are located at R2, while the three MSB bits, A12~A10, are located at R3. The Program Counter is cleared after Power-on reset or Watchdog reset. The first instruction that is executed after a reset is located at address 00h.

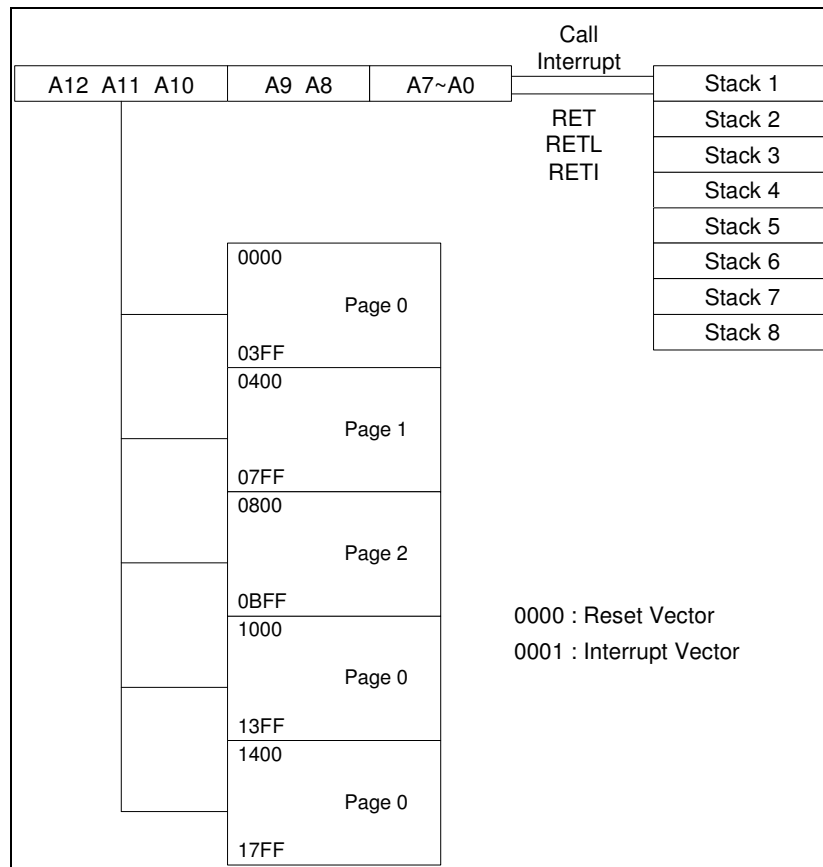

8.2.2.4 R3 (Status Register) Default Value:(0B_0001_1XXX)

Bit 7	Bit 6	Bit 5	Bit 4	Bit 3	Bit 2	Bit 1	Bit 0
PS2	PS1	PS0	T	P	Z	DC	C

R3 [0] Carry/Borrow Flag

0 = No carry-out from the result's Most Significant bit

1 = A carry-out from the result's Most Significant bit occurred

NOTE

For Borrow, the polarity is reversed. For rotate (RRC, RLC) instructions, this bit is loaded with either high or low-order bit of the source register.

R3 [1] Auxiliary Carry/Borrow Flag. For ADD, SUB Instructions

0 = No carry-out from the 4th low-order bit of the result

1 = A carry-out from the 4th low-order bit of the result occurred

NOTE

For Borrow, the polarity is reversed.



R3 [2] Zero flag. It will be set to 1 when the result of an arithmetic or logic operation is zero.

R3 [3] Power down flag. It will be set to 1 during Power-on phase or by "WDTC" command and cleared when the MCU enters into Power down mode. It remains in its previous state after a Watchdog Reset.

0: Power down

1: Power-on

R3 [4] Time-out flag. It will be set to 1 during Power-on phase or by "WDTC" command. It is reset to 0 by WDT time-out.

0: Watchdog timer overflow occurs

1: No Watchdog timer overflow

The various states of Power down flag and Time-out flag at different conditions are shown below:

T	P	Condition
1	1	Power-on reset
1	1	WDTC instruction
0	*P	WDT time-out
1	0	Power down mode
1	0	Wake up caused by port change during Power down mode

*P: Previous status before WDT reset

R3 [5-7] Page selection bits. These three bits are used to select the program memory page.

PS2	PS1	PS0	Program Memory Page [Address]
0	0	0	Page 0 [0000-03FF]
0	0	1	Page 1 [0400-07FF]
0	1	0	Page 2 [0800-0BFF]
0	1	1	Page 3 [0C00-0FFF]
1	0	0	Page 4 [1000-13FF]
1	0	1	Page 5 [1400-17FF]



8.2.2.5 R4 (RAM Select Register) Default Value: (0B_00XX_XXXX)

Bit 7	Bit 6	Bit 5	Bit 4	Bit 3	Bit 2	Bit 1	Bit 0
BK1	BK0	Ad5	Ad4	Ad3	Ad2	Ad1	Ad0

R4 (RAM select register) contains the address of the registers.

R4 [0~5] used to select registers in 0x00h~0x3Fh. The address 0x00~0x1F is common space. After 0x1Fh, SRAM is divided into four banks, using Bank Select Register.

R4 [6, 7] used to select the registers bank (refer to the table below). The following are two examples:

- (1) R4=00001100 and R4=10001100 point to the same register 0x0Ch. Since 0x0Ch is in the common space, Bit 6 and Bit 7 are meaningless.
- (2) R4=10111100 points to the register 0x3C in Bank 2.

R4[7]Bk1	R4[6]Bk0	RAM Bank #
0	0	Bank 0
0	1	Bank 1
1	0	Bank 2
1	1	Bank 3

8.2.2.6 R5 (Port 5 I/O Register) Default Value: (0B_0000_0000)

Bit 7	Bit 6	Bit 5	Bit 4	Bit 3	Bit 2	Bit 1	Bit 0
P57	P56	P55	P54	P53	P52	P51	P50

8.2.2.7 R6 (Port 6 I/O Register) Default Value: (0B_0000_0000)

Bit 7	Bit 6	Bit 5	Bit 4	Bit 3	Bit 2	Bit 1	Bit 0
P67	P66	P65	P64	P63	P62	P61	P60

8.2.2.8 R7 (Port 7 I/O Register) Default Value: (0B_0000_X000)

Bit 7	Bit 6	Bit 5	Bit 4	Bit 3	Bit 2	Bit 1	Bit 0
P77	P76	D- / P75 / DATA	D+ / P74 / CLK	-	P72	P71	P70

8.2.2.9 R8 (Port 8 I/O Register) Default Value: (0B_0000_0000)

Bit 7	Bit 6	Bit 5	Bit 4	Bit 3	Bit 2	Bit 1	Bit 0
P87	P86	P85	P84	P83	P82	P81	P80

8.2.2.10 R9 (Port 9 I/O Register) Default Value: (0B_X00X_0000)

Bit 7	Bit 6	Bit 5	Bit 4	Bit 3	Bit 2	Bit 1	Bit 0
-	P96	P95	-	P93	P92	P91	P90



8.2.2.11 RA (EEPROM Control Register) *Default Value: (0B_1111_1111)*

RA is a command register for EEPROM control. For detailed usage of this register, refer to Section 8.2.3 which describes the EEPROM embedded in the EM78M611E.

8.2.2.12 RB (Pattern Detect Application Control Register)

Default Value: (0B_0000_0000)

RB is a control register for controlling the Pattern Detect Application function. For detailed description of this register, refer to Section 8.7.2 which describes the PDA function.

8.2.2.13 RC (USB Application Status Register) *Default Value: (0B_0000_0000)*

Bit 7	Bit 6	Bit 5	Bit 4	Bit 3	Bit 2	Bit 1	Bit 0
EP0_W	EP0_R	EP1_R	EP2_R	EP2_W	Host_Suspend	EP0_Busy	Stall

RC [0] Stall flag. While the MCU receives an unsupported command or invalid parameters from host, this bit will be set to 1 by the firmware to notify the UDC to return a STALL handshake. When a successful Setup transaction is received, this bit is cleared automatically. This bit is readable and writable.

RC [1] EP0_Busy flag. When this bit is equal to "1," it indicates that the UDC is writing data into the EP0's FIFO or reading data from it. During this time, the firmware will avoid accessing the FIFO until UDC finishes writing or reading. This bit is only readable.

RC [2] Host Suspend flag. If this bit is equal to 1, it indicates that USB bus has no traffic for a specified period of 3.0 ms. This bit will also be cleared automatically when there is bus activity. This bit is only readable.

RC [3] EP2_W flag. This bit is set when the UDC receives a successful data from USB Host to EP2. Upon detecting that this bit is equal to one, the firmware will execute a read sequence to the EP2's FIFO, after which this bit is cleared. Otherwise, the subsequent data from USB Host won't be accepted by the UDC.

RC [4, 5, 6] EP0_R / EP1_R / EP2_R flag. These three bits inform the UDC to read the data from the FIFO. Then the UDC will send the data to the Host automatically. After UDC finishes reading the data from the FIFO, this bit will be cleared automatically.

Therefore, before writing data into FIFO's, the firmware will first check this bit to avoid overwriting the data. These three bits can only be set by firmware and cleared by hardware.

RC [7] EP0_W flag. After the UDC completes writing data to the FIFO, this bit will be set automatically. The firmware will clear it as soon as it gets the data from EP0's FIFO. Only when this bit is cleared that the UDC will be able to write a new data into the FIFO.

Therefore, before the firmware can write data into the FIFO, this bit must first be set by the firmware to prevent the UDC from writing data at the same time. This bit is both readable and writable.



8.2.2.12 RD (USB Application FIFO Address Register)

Default Value: (0B_0000_0000)

Bit 7	Bit 6	Bit 5	Bit 4	Bit 3	Bit 2	Bit 1	Bit 0
0	0	0	UAD4	UAD3	UAD2	UAD1	UAD0

RD [0~4] USB Application FIFO address registers. These five bits are the address pointers of USB Application FIFO.

RD [5~7] Undefined registers. The default value is zero.

8.2.2.13 RE (USB Application FIFO Data Register)

Default Value: (0B_0000_0000)

Bit 7	Bit 6	Bit 5	Bit 4	Bit 3	Bit 2	Bit 1	Bit 0
UD7	UD6	UD5	UD4	UD3	UD2	UD1	UD0

RE (USB Application FIFO data register) contains the data in the register of which address is pointed by RD.

NOTE

For example, if user wants to read the fourth byte of EndPoint Zero, user has to use the address of EP0 (0x00) and Data Byte Pointer of EP0 (0x10) to access it.

// Read the 4th byte of the EP0 FIFO

// First, assign the data byte pointer of EP0 register (0X10) with 0X03.

MOVA, @0X10

MOV RD, a // Move data in A to RD register

MOVA, @0X03

MOV RE, A // Move data in A to RE register

// Then read the content from EP0 FIFO (0x00) 4th byte

MOVA, @0X00

MOV RD, A // Assign address point to EP0 FIFO

MOVA, RE // Read the fourth byte data (Byte 3) of the EP0 FIFO

MOV A, 0X0E // Read the fifth byte data (Byte 4) of the EP0 FIFO

8.2.2.14 RF (Interrupt Status Register) Default Value: (0B_0000_0000)

Bit 7	Bit 6	Bit 5	Bit 4	Bit 3	Bit 2	Bit 1	Bit 0
USB Host Resume_IF	SE2_IF	SE1_IF	Port7 state change_1F	USB Reset_IF	USB Suspend_IF	EP0_IF	TCC_IF

RF [0] TCC Overflow interrupt flag. It will be set while TCC overflows, and is cleared by firmware.

RF [1] EndPoint Zero interrupt flag. It will be set when the EM78M611E receives Vendor/Customer Command to EndPoint Zero. This bit is cleared by firmware.



- RF [2] USB Suspend interrupt flag. It will be set when the EM78M611E finds the USB Suspend Signal on USB bus. This bit is cleared by the firmware.
- RF [3] USB Reset interrupt flag. It will be set when the host issues the USB Reset signal.
- RF [4] P74/P75/P76/P77 Port state change interrupt flag.

In PS2 Mode, only pins configured as inputs can cause this interrupt to occur. These pins (P74, P75, P76 and P77) are compared with the value latched on the last read of Port 7.

In USB Mode, P76 and P77 have this function.

NOTE

*RF [4]: Port State Change Interrupt Flag,
EM78M611
USB Mode – P76 and P77 DO NOT have interrupt function.
PS2 Mode – P74/P75/P76/P77 have interrupt function.
EM78M611E
P74/P75/P76/P77 all have interrupt function (in USB & PS2 mode)*

- RF [5, 6] SE1 / SE2 Pattern Detect Interrupt flag. These two flags are used for Pattern detect application.
- RF [7] USB Host Resume interrupt flag. It will be set only in Dual clock mode when the USB suspend signal becomes low.

NOTE

*RF [7]: USB Host Resume_IF
In EM78M611, this bit is always '1'. It is **not** for use.
In EM78M611E, this bit is **O.K.** for use.*

8.2.3 Control Registers

Some special purpose registers are available for special control purposes. Except for the Accumulator (ACC), these registers must be read and written with special instructions. One of these registers, CONT, can only be read by the instruction "CONTR" and written by "CONTW" instruction. The other special control registers can be read by the instruction "IOR" and written by the instruction "IOW".

The following paragraphs describe only the general functions of the control registers.

8.2.3.1 A (Accumulator)

The accumulator is an 8-bit register that holds operands and results of arithmetic calculations. It is not addressable. After an interrupt occurs, the Accumulator is auto-saved by hardware.



8.2.3.2 CONT (Control Register) Default Value: (0B_0011_1111)

Bit 7	Bit 6	Bit 5	Bit 4	Bit 3	Bit 2	Bit 1	Bit 0
LED	INT	TSR2	TSR1	TSR0	PSR2	PSR1	PSR0

Except for Bit 6 (Interrupt enable control bit), the CONT register can be read by the instruction "CONTR" and written by the instruction "CONTW".

CONT [0~2] Watchdog Timer prescaler bits. These three bits are used as the Watchdog Timer prescaler.

CONT [3~5] TCC Timer prescaler bits.

The relationship between the prescaler value and these bits are shown below:

PSR2/TSR2	PSR1/TSR1	PSR0/TSR0	TCC Rate	WDT Rate
0	0	0	1: 2	1: 1
0	0	1	1: 4	1: 2
0	1	0	1: 8	1: 4
0	1	1	1: 16	1: 8
1	0	0	1: 32	1: 16
1	0	1	1: 64	1: 32
1	1	0	1: 128	1: 64
1	1	1	1: 256	1: 128

NOTE

WDT Timing base is "Power-on time". Set by the code option [2, 1.]
 Ex. Code option [2, 1] = 01 (2ms), and Prescaler = 1:128.
 WDT overflow time is: $2mS * 2^7 = 256 mS$

CONT [6] Interrupt enable control bit. This bit toggles Interrupt function between enable and disable. It is set to 1 by the interrupt disable instruction "DISI" and reset by the interrupt enable instructions "ENI" or "RETI."

0 : Disable the Interrupt function

1 : Enable the Interrupt function

CONT [7] LED bit. This bit is used to enable the LED sink capacity of P76 and P77.

0 : Disable the LED sink capacity of P76, P77

1 : Enable the LED sink capacity of P76, P77



8.2.3.3 IOC5 ~IOC9 I/O (Port Direction Control Registers)

Default Value: (0B_1111_1111)

These are I/O port (Port 5 ~ Port 7) direction control registers. Each bit controls the I/O direction of three I/O ports respectively. When these bits are set to 1, the relative I/O pins become input pins. Similarly, the I/O pins becomes outputs when the relative control bits are cleared.

- 0 : Output direction
- 1 : Input direction

8.2.3.4 IOCA (Operation Mode Control Register) *Default Value: (0B_1110_0000)*

Bit 7	Bit 6	Bit 5	Bit 4	Bit 3	Bit 2	Bit 1	Bit 0
Dual_Frq.1	Dual_Frq.0	-	Remote_Wake up	ExReg_Sel	PDA	PS/2	USB

IOCA [0, 1] These two bits are used to select the operation mode.

IOCA[1]	IOCA[0]	Operation Mode
0	0	Detect Mode
0	1	USB Mode
1	0	PS/2 Mode
1	1	USB Test Mode

IOCA[2] Pattern Detect Application function enable bit. This bit is used to enable the Pattern Detect Application (PDA) function. For details about this function refer to Section 8.11.

- 0 : Disable PDA function
- 1 : Enable PDA function

IOCA[3] Extra control register select bit. The five extra control registers (REA, REB, REC, RED, and REE) are located in 0xA~0xE. To access these five registers, set the bit as follows:

- 0 : Select RA~RE
- 1 : Select Extra Control register ERA~ERE

IOCA[4] Indicate whether the device is currently requested to support remote wake up or not. The Remote Wake-up field can be modified by SetFeature () and ClearFeature () requests.

- 0 : Do Not support remote wake up
- 1 : Supports remote wake up

NOTE

*IOCA[4]: Remote_Wake up bit
EM78M611 do **NOT** support this function. Only EM78M611E does.*



IOCA [6, 7] Select the operation frequency in Dual Clock Mode. Four frequencies are available and can be chosen as Dual Clock Mode in running the MCU program.

Dual_Frq.1	Dual_Frq.0	Frequency
0	0	500Hz
0	1	4kHz
1	0	32kHz
1	1	256kHz

8.2.3.5 IOCB (Port 9 Wake-up Pin Select Register)

Default Value: (0B_X111_1111)

Bit 7	Bit 6	Bit 5	Bit 4	Bit 3	Bit 2	Bit 1	Bit 0
–	/P96	/P95	/P94	/P93	/P92	/P91	/P90

IOCB [0~6] These bits are used to select which of the Port 9 pins is to be assigned to wake up the MCU while in Power down mode.

0 : Enable the function

1 : Disable the function

IOCB[7] Reserved bit

8.2.3.6 IOCC (Port 9 LED Sink Capacity Control Register)

Default Value: (0B_X00X_0000)

Bit 7	Bit 6	Bit 5	Bit 4	Bit 3	Bit 2	Bit 1	Bit 0
–	P96	P95	–	P93	P92	P91	P90

IOCC [0~3, 5, 6] LED sink control bit. These bits are used to enable the LED sink capacity of P90 ~ P97

0 : Disable the LED sink capacity of respective pin

1 : Enable the LED sink capacity of respective pin

IOCC [4, 7] Reserved bits

8.2.3.7 IOCD (Port 9 Pull High Control Register) Default Value: (0B_X11X_1111)

Bit 7	Bit 6	Bit 5	Bit 4	Bit 3	Bit 2	Bit 1	Bit 0
–	/PH96	/PH95	–	/PH93	/PH92	/PH91	/PH90

IOCD [0~3, 5, 6] These bits control the 25KΩ pull-high resistor of individual pins in Port 9.

0 : Enable the pull-high function

1 : Disable the pull-high function

IOCD [4, 7] Reserved bits



8.2.3.8 IOCE (Special Function Control Register) Default Value: (0B_1101_0111)

Bit 7	Bit 6	Bit 5	Bit 4	Bit 3	Bit 2	Bit 1	Bit 0
/Dual clock	/WUE	WTE	RUN	Device_Resume	/PU8	/PU6	/PU5

IOCE [0, 1, 2] Port 5, Port 6, and Port 8 pull-high control bits.

- 0 : Enable
- 1 : Disable

IOCE [3] Setting this bit will allow the UDC to execute resume signaling. This bit is set by firmware to generate a signal to wake-up the USB host and is cleared as soon as the USB Suspend signal becomes low. It can only be used in Dual clock mode when the USB suspend signal becomes low.

NOTE

IOCE[3]: Device_Resume bit
*In EM78M611, this bit is always '0'. It is **not** for use.*
*In EM78M611E, this bit is **O.K.** for use.*

IOCE [4] Run bit. This bit can be cleared by firmware and set during power-on, or by the hardware at a falling edge of the wake-up signal. When this bit is cleared, the clock system is disabled and the MCU enters into Power down mode. At the transition of wake-up signal from high to low, this bit is set to enable the clock system.

- 0 : Sleep mode. The EM78M611E is in power down mode.
- 1 : Run mode. The EM78M611E is working normally.

IOCE [5] Watchdog Timer enable bit. The bit disables/enables the Watchdog Timer.

- 0 : Disable WDT
- 1 : Enable WDT

IOCE [6] Enable the wake-up function as triggered by port-changed. This bit is set by UDC.

- 0 : Enable the wake-up function
- 1 : Disable the wake-up function

IOCE [7] Dual clock Control bit. This bit is used to select the frequency of system clock. When this bit is cleared, the MCU will run on very low frequency for power saving and the UDC will stop working.

- 0 : Selects to run on slow frequency
- 1 : Selects EM78M611E to run on normal frequency



8.2.3.9 IOCF (Interrupt Mask Register) Default Value : (0B_0000_0000)

Bit 7	Bit 6	Bit 5	Bit 4	Bit 3	Bit 2	Bit 1	Bit 0
USB Host Resume_I E	SE2_IE	SE1_IE	Port7 state change_1E	USB Reset_IE	USB Suspend_IE	EP0_IE	TCC_IE

IOCF [0~7] TCC / EP0 / USB Suspend / USB Reset / Port 7 State Change / SE1_IE / SE2_IE / USB Host Resume interrupt enable bits. These eight bits control the TCC interrupt function, EP0 interrupt, USB Suspend interrupt, USB Reset interrupt, Port 7 State Change interrupt and USB Host Resume interrupt respectively. Individual interrupt is enabled by setting its associated control bit in the IOCF to "1."

0 : Disable Interrupt

1 : Enable Interrupt

Only when the global interrupt is enabled by the ENI instruction will the individual interrupt work. After DISI instruction, any interrupt will not work even if the respective control bits of IOCF are set to 1.

The USB Host Resume Interrupt works only in Dual clock mode. This is because when the MCU is in sleep mode, it will be automatically woken up by the UDC Resume signal.

8.3 Extra Control Register

Five extra control registers are available to control some special functions. The five registers are ERA (AD Control register), ERB (AD_LSB), ERC (AD_MSB), ERD (AD_Rate), and ERE (PWM Control register)

Remember to set IOCA[3] before accessing these five registers. The operating method is the same as with other control registers.

8.4 USB Application FIFOs

For USB Application, EM78M611E provides an 8-byte First-In-First-Out (FIFO) buffer for each endpoint. The buffer cannot be accessed directly. However, a corresponding Data Byte Pointer register for each endpoint is made available to address the individual byte of the FIFO buffer. The content of the individual byte will map to a special register.

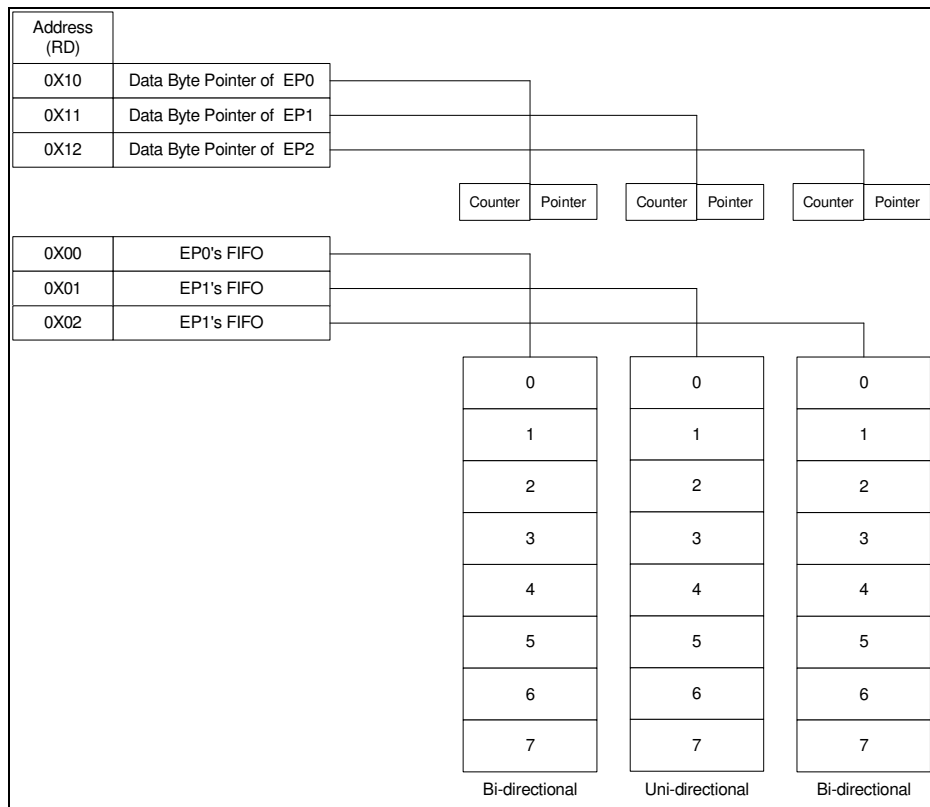

8.5 USB Application

EM78M611E is designed specially for USB device application and has many powerful functions that support the firmware to free itself from complex situation in various aspects of USB application.

8.5.1 USB Device Controller

The EM78M611E built-in USB Device Controller (UDC) can interpret the USB Standard Command and respond automatically without involving firmware. The embedded Series Interface Engine (SIE) handles the serialization and de-serialization of actual USB transmission. Thus, a developer can concentrate his efforts more in perfecting the device actual functions and spend less energy in dealing with USB transaction.

The UDC handles and decodes most Standard USB commands defined in the USB Specification Rev1.1. If the UDC receives an unsupported command, it will set a flag to notify the MCU of the receipt of such command. The Standard Commands that the EM78M611E supports includes; **Clear Feature, Get Configuration, Get Interface, Get Status, Set Address, Set Configuration, Set Feature, and Set Interface.**

Each time the UDC receives a USB command, it writes the command into the EP0's FIFO. Only when it receives unsupported command will the UDC notify the MCU through interrupt.

Hence, the EM78M611E is very flexible under USB application since the developer can freely choose the method of decoding the USB command as dictated by different situation.

8.5.2 Device Address and Endpoints

EM78M611E supports one device address and three endpoints, EP0 for control endpoint, EP1 and EP2 for interrupt endpoint. Sending data to USB host in EM78M611E is very easy. Just write data into EP's FIFO, then set flag, and the UDC will handle the rest. It will then confirm that the USB host has received the correct data from EM78M611E.

8.6 Reset

The EM78M611E provides three types of reset: (1) Power-on Reset, (2) Watchdog Reset, and (3) USB Reset.

8.6.1 Power-on Reset

Power-on Reset occurs when the device is attached to power and a reset signal is initiated. The signal will last until the MCU becomes stable. After a Power-on Reset, the MCU enters into the following predetermined states (see below), and then, it is ready to execute the program.

- a. The program counter is cleared.
- b. The TCC timer and Watchdog timer are cleared.
- c. Special registers and Special Control registers are all set to their initial values.

8.6.2 Watchdog Reset

When the Watchdog timer overflows, it causes the Watchdog to reset. After it resets, the program is executed from the beginning and some registers will be reset. The UDC however, remains unaffected.

8.6.3 USB Reset

When the UDC detects a USB Reset signal on the USB Bus, an MCU interrupt occurs, after which it proceeds to perform the specified process that follows. After a USB device is attached to the USB port, it cannot respond to any bus transactions until it receives a USB Reset signal from the bus.

8.7 Saving Power Mode

The EM78M611E provides two options of power-saving modes for energy conservation, i.e., Power Down mode and Dual clock mode.

8.7.1 Power Down Mode

The EM78M611E enters into Power Down mode by clearing the RUN register (IOCE[4]). During this mode, the oscillator is turned off and the MCU goes to sleep. It will wake up when signal from USB host is resumed, or when a Watchdog reset occurs or when an input port state changes.

If the MCU wakes up when I/O port status changes, the direction of the I/O port should be set at input direction, and then read the state of port. For example:



```
:  
// Set the Port 6 to input port  
MOV      A, @0xFF  
IOW      PORT6  
// Read the state of Port 6  
MOV      PORT6, PORT6  
// Clear the RUN bit  
IOR      0xE  
AND      A, 0B11101111  
IOW      0xE  
:  
:
```

8.7.2 Dual Clock Mode

The EM78M611E has one internal oscillator for power saving application. Clearing the Bit IOCE [7] will enable the low frequency oscillator. At the same time, the external oscillator will be turned off. Then the MCU will run under very low frequency to conserve power. Four types of frequency are available for selection in setting bits IOCA [6, 7].

The USB Host Resume Interrupt can only be used in this mode. If this interrupt is enabled, the MCU will be interrupted when the USB Host Resume signal is detected on USB Bus.

8.8 Interrupt

The EM78M611E has one interrupt vector in 0x0001. When an interrupt occurs during an MCU program run, it will jump to the interrupt vector (0x0001) and execute the instructions sequentially from the interrupt vector. RF is the interrupt status register, which records the interrupt status in the relative flags/bits.

The interrupt condition could be one of the following:

TCC Overflow: When the Timer Clock / Counter Register (R1) overflows, the status flag RF[0] will be set to 1. Its interrupt vector is 0X0001.

Port 7 State Change: When the input signals in Port 7 changes, the status flag RF[4] will be set to 1. Its interrupt vector is 0X0001.

SE1 Pattern Detection Interrupt Conditions: If the Pattern Detection Application function is enabled, there will be four conditions with which interrupt is generated, and the status flag RF[5] is set to 1 (interrupt vector is 0X0001).

- a) Signal from P.92 changes to low and the Pattern Counter value is bigger than R11 register value.

- b) Signal from P.92 changes to high, and Pattern Counter value bigger than R10 register value.
- c) P.92 remains high, and the Pattern Counter value is equal to 0XFF.
- d) P.92 remains low, and the Pattern Counter value is equal to 0XFF.

SE2 Pattern Counter Interrupt Conditions: If the Pattern Detection Application function is enabled, there will be three conditions with which interrupt is generated and the status flag RF[6] is set to 1 (interrupt vector is 0X0001).

- a) Signal from P.93 changes to low and the Pattern Counter value is bigger than R13 register value.
- b) Signal from P.93 changes to high and the Pattern Counter value is bigger than R12 register value.
- c) P.93 remains high, and the Pattern Counter value is equal to 0XFF.
- d) P.93 remains low, and the Pattern Counter value is equal to 0XFF.

EP0 interrupt: When the UDC successfully accepts a setup transaction from host to EndPoint0, the status flag RF[1] is set to 1. Its interrupt vector is 0X0001.

USB suspend: When UDC detects a USB Suspend signal on the USB bus, the status flag RF[2] is set to 1. Its interrupt vector is 0X0001.

USB Reset: When the UDC detects a USB Reset signal on the USB bus, the status flag R[3] is set to 1. Its interrupt vector is 0X0001.

USB Host Resume: When the UDC detects that the USB bus is no longer in Suspend condition and without Device Resume signal, the status flag R[7] is set to 1. Its interrupt vector is 0X0001.

IOCF is an interrupt mask register which can be set bit by bit. While their respective bit is written to 0, the hardware interrupt will inhibit, that is, the EM78M611E will not jump to the interrupt vector to execute instructions. But the interrupt status flags still records the conditions no matter whether the interrupt is masked or not. The interrupt status flags must be cleared by firmware before leaving the interrupt service routine and enabling other interrupt.

The global interrupt is enabled by the ENI (RETI) instruction and is disabled by the DISI instruction.

8.9 Pattern Detect Application (PDA)

8.9.1 Function Description

This function is designed for the serial signal transmission, e.g., the transmission between a wireless device and its receiver box. The EM78M611 has two sets of built-in Pattern Detect Application block that ensures the EM78M611 is equipped with a compound device, such as the receiver box controller for a wireless keyboard paired with a wireless mouse.



Pattern Detect Application (PDA) can calculate the length of one pattern and interrupt the MCU while the serial signal is transiting from high to low (or vise-versa). Then the MCU reads the length value from a specified register.

8.9.2 Control Register

The PDA includes an enable control bit, one control register and 4-length counter registers in 0x10 ~0x13.

IOCA [2] PDA Enable Control Bit

When this bit is set, the PDA function starts and the P92 and P93 become input pin automatically to sample the serial signal.

0 : disable PDA function

1 : enable PDA function

RB (PDA Control Register) Default Value: (0B_0000_0000)

Bit 7	Bit 6	Bit 5	Bit 4	Bit 3	Bit 2	Bit 1	Bit 0
SE2.F	SE1.F	SR.2	SR.1	SR.0	DB2	DB1	DB0

This register is used to define two parameters of PDA function; signal sampling rate and debounce length. When a pattern ends, the value in the counter is loaded into its respective register and the RB[6] or RB[7] is set to indicate which type of pattern (high or low) is at its end or which type of pattern counter is on overflow.

0: low pattern

1: high pattern

R10 (P.92 Low Pattern Counter)

This register records the length of P.92 in low status.

R11 (P.92 High Pattern Counter)

This register records the length of P.92 in high status.

R12 (P.93 Low Pattern Counter)

This register record the length of P.93 in low status.

R13 (P.93 High Pattern Counter)

This register records the length of P.93 in high status.

R10~R13 function as general registers if this function is not enabled. Once the enabled bit is set, these four registers will be loaded with the value of the pattern counter.

8.9.3 Sampling Rate and Debounce Length

Although the two-pattern detect pins are separate, and each pin has its own pattern counter, both pins use the same Sampling Rate and Debounce Length parameters.

The PDA samples the serial signal every fixed interval. The pattern counter will be incremented by one at sampling time if the signal remains unchanged. If the signal is at



high state, then the "high pattern counter" will increase; otherwise the "low pattern counter" increases. As long as the signal state changes, the PDA will debounce signal and load the value of pattern counter into the respectively register for the firmware to read. For example, if the signal in P.92 is in "low" state, the low counter of P.92 will count continuously until the state of the input signal in P.92 changes. When a state change occurs (in this case, the signal changes from "low" to "high" state), the PDA will take a time break (which is equal to the result of sampling interval multiplied by the debounce length), to avoid possible noise. After the debounce length time, if the signal remains in high state, the high pattern counter will start to count and load the low pattern counter's value into R10. At the same time, RB[6] is cleared to indicate that low pattern is over.

The correlation between the control register value and debounce time are as follows:

DB.2	DB.1	DB.0	Debounce Time
0	0	0	0
0	0	1	Sampling clock
0	1	0	Sampling clock × 2
0	1	1	Sampling clock × 3
1	0	0	Sampling clock × 4
1	0	1	Sampling clock × 5
1	1	0	Sampling clock × 6
1	1	1	Sampling clock × 7

On the other hand, when the signal of P92 always remains "low", the low pattern counter of P92 will eventually overflow. Once the counter overflows, the content of the counter will also be loaded into R10, that is, the register is written to 0xFF, and the counter is reset to count from zero again.

If the hardware interrupt of PDA function is enabled, (IOCF[5] is equal to "1"), then the program will go to 0x0001 to execute interrupt routine while the content of a pattern counter is loaded into the register.

The correlation between the value of control register and actual sampling rate are as shown below:

SR.2	SR.1	SR.0	Sampling Rate (External oscillator frequency = 6MHz)	Sampling Rate (External oscillator frequency = 12MHz)
0	0	0	N.A.	N.A.
0	0	1	N.A.	N.A.
0	1	0	1500 (Count / mSec)	N.A.
0	1	1	750 (Count / mSec)	1500 (Count/ mSec)
1	0	0	375 (Count / mSec)	750 (Count / mSec)
1	0	1	188 (Count / mSec)	375 (Count / mSec)
1	1	0	94 (Count / mSec)	188 (Count / mSec)
1	1	1	47 (Count / mSec)	94 (Count / mSec)



After the PDA function is enabled (by setting IOCA[2] to 1), user can write a default value to the High Pattern counter register and Low Pattern counter register. Then set the corresponding interrupt enable bit (IOCF[5]). When the counting value of one “H” pattern is bigger than the default value of R11, the Pattern Detecting interrupt will be generated. Similarly, if the counting value of one “L” pattern is bigger than the default value of R10, Low Pattern Detecting interrupt will occur. Thus, the EM78M611 is notified and aware that one effective pattern is received from P.92.

If user does not need these two interrupts, they can be masked. The new value of counting a pattern will still be loaded to the R10 and R11. The firmware must poll and determine whether the value of these two registers has changed or not.

8.10 Pulse Width Modulation (PWM)

8.10.1 Function Description

In PWM mode, both PWM1 (P.92) and PWM2 (P.93) produce plus programmable signal of up to 8 bits resolution.

The PWM Period is defined as $0xFF \times \text{Timer Counter Clock}$. The Timer Counter clock source is controlled by an extra control register, ERE. For example; if the Clock source is 1MHz, then the Period will be 255 μ seconds.

$$\text{Period} = 255 \times (1/\text{Timer Counter Clock})$$

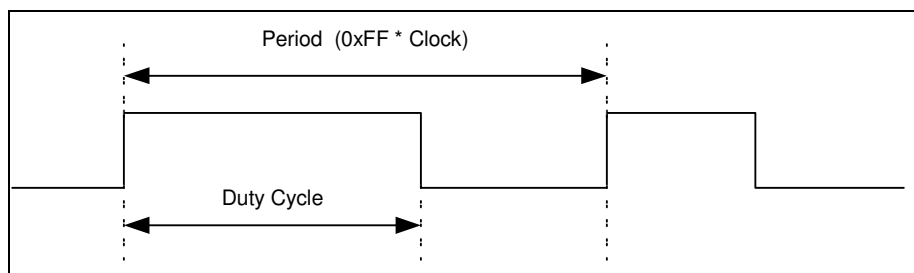

Fig. 8-2 The PWM Output Timing

8.10.2 Duty Cycle

The PWM duty cycle is defined by writing to the R10/R11 Register for PWM1/PWM2.

$$\begin{aligned} \text{Duty Cycle} &= (R10 / 255) \times 100\% \text{ for PWM1} \\ &= (R11 / 255) \times 100\% \text{ for PWM2} \end{aligned}$$

8.10.3 Control Register

R10 (PWM1 Duty Cycle Register)

A specified value keeps the output of PWM1 to remain at high for a Period.

R11 (PWM2 Duty Cycle Register)

A specified value keeps the output of PWM2 to remain at high for a Period.

ERE(PWM Control Register) Default Value: (0B_0000_0001)

Bit 7	Bit 6	Bit 5	Bit 4	Bit 3	Bit 2	Bit 1	Bit 0
PEN2	PEN1	-	-	-	PS2	PS1	PS0



ERE [0~2] PWM Clock Prescaler

PS2	PS1	PS0	Clock (Hz)	Period/255 (s)
0	0	0	Fosc/3	0.5μ
0	0	1	Fosc/6	1μ
0	1	0	Fosc/12	2μ
0	1	1	Fosc/24	4μ
1	0	0	Fosc/48	8μ
1	0	1	Fosc/96	16μ
1	1	0	Fosc/192	32μ
1	1	1	Fosc/384	64μ

ERE [6, 7] PWM1/PWM2 Enable Bit

0 : Disable

1 : Enable

8.11 Analog-To-Digital Converter (ADC)

8.11.1 Function Description

The Analog to Digital converter consists of a 5-bit analog multiplexer, one Control Register (ERA), and two data registers (RBS & RCS) for 10-bit resolution.

The ADC module utilizes successive approximation to convert the unknown analog signal to a digital value. The result is fed to the ADDATA. Input channels are selected by the analog input multiplexer via the ADCS/RAS bits AD0~AD4.

10-bit resolution: 0x00-00~0xC0-FF (0b11000000-11111111)

Start (0x00-00): $0 \text{ Vref} \sim (1/1024) \times \text{Vref}$

Full (0xC0-FF): $(1023/1024) \times \text{Vref} \sim \text{Vref}$

Conversion Time: 12 clock time of internal clock source

8.11.2 Control Register

ERA (AD Channel Select Register) *Default Value: (0B_0001_1111)*

Bit 7	Bit 6	Bit 5	Bit 4	Bit 3	Bit 2	Bit 1	Bit 0
ADC	0	0	AD4	AD3	AD2	AD1	AD0



ERA [0~4]: AD Channel Selector

AD4	AD3	AD2	AD1	AD0	Channel	I/O Port
0	0	0	0	0	0	P50
0	0	0	0	1	1	P51
0	0	0	1	0	2	P52
0	0	0	1	1	3	P53
0	0	1	0	0	4	P54
0	0	1	0	1	5	P55
0	0	1	1	0	6	P56
0	0	1	1	1	7	P57
0	1	0	0	0	8	P80
0	1	0	0	1	9	P81
0	1	0	1	0	10	P82
0	1	0	1	1	11	P83
0	1	1	0	0	12	P84
0	1	1	0	1	13	P85
0	1	1	1	0	14	P86
0	1	1	1	1	15	P87
1	0	0	0	0	16	P60
1	0	0	0	1	17	P61
1	0	0	1	0	18	P62
1	0	0	1	1	19	P63
1	0	1	0	0	20	P64
1	0	1	0	1	21	P65
1	0	1	1	0	22	P66
1	0	1	1	1	23	P67

ERA [7] AD Converter ready flag

0 → 1: Start AD Conversion (set by firmware).

1 → 0: When AD conversion is finished and has moved digital data into the AD Data Register, this bit will be set by hardware.

NOTE

Hardware can enable this function only at AD Channel Select of the functional I/O port. After a power-on reset, the initial value of this register is 0b0001_1111.

ERB (AD LSB Data Register) Default Value: (0B_0000_0000)

Bit 7	Bit 6	Bit 5	Bit 4	Bit 3	Bit 2	Bit 1	Bit 0
Bit 1	Bit 0	0	0	0	0	0	0

8 bits AD LSB Digital Data



ERC (AD MSB Data Register) *Default Value: (0B_0000_0000)*

Bit 7	Bit 6	Bit 5	Bit 4	Bit 3	Bit 2	Bit 1	Bit 0
Bit 9	Bit 8	Bit 7	Bit 6	Bit 5	Bit 4	Bit 3	Bit 2

2 bits AD MSB Digital Data.

ERD (AD Control Register) *Default Value: (0B_0000_0000)*

Bit 7	Bit 6	Bit 5	Bit 4	Bit 3	Bit 2	Bit 1	Bit 0
0	0	0	0	0	-	ADPS1	ADPS0

ERD [0 1]: The clock source of AD converting time.

- 00: 256kHz
- 01: 128kHz
- 10: 64kHz
- 11: 32kHz

8.12 EEPROM

Four bytes of EEPROM are located in the R2C~R2F of Bank 3. The stored data of EEPROM are not erased when the power is off and can be read and re-written by firmware. In some special case of application, for example, cordless keyboard controller, it can store important data, such as the cordless keyboard's device identical number.

A control register, ERA controls the EEPROM, that is, to read, write, or to erase the data from EEPROM. Writing a command into this register will execute an action to the EEPROM. The command value is defined in the following table. Note that there is an execution time laps for each command. Before writing the next command into the control register, allow enough time for the EEPROM to finish the previous command.

Command Value	Action	Execution Time
0B_0000_0000	Read	1 ms
0B_0000_0001	Write	9 ms
0B_0000_0010	Erase	128 ms
0B_0000_0011	Disable	N.A.



9 Absolute Maximum Ratings

Symbol	Min	Max	Unit
Temperature under bias	0	70	°C
Storage temperature	-65	150	°C
Input voltage	-0.5	6.0	V
Output voltage	-0.5	6.0	V

10 DC Electrical Characteristic

T = 25°C, VDD=5V, VSS=0V

Symbol	Parameter	Condition	Min	Type	Max	Unit
3.3V Regulator						
V _{Rag}	Output voltage of 3.3V Regulator	V _{DD} = 5V	3.0	3.3	3.6	V
V _{ResetL}	Low Power Reset detecting low Voltage	-	-	-	2.2	V
V _{ResetH}	Low Power Reset detecting high Voltage	-	3.0	-	-	V
I _{reg}	3.3V Regulator driving capacity	V _{3.3} = 3.3V	-	-	100	mA
MCU Operation						
I _{IL}	Input Leakage Current for input pins	V _{IN} =V _{DD} , V _{SS}	-	-	±1	µA
V _{IHX}	Clock Input High Voltage	OSCI	2.5	-	-	V
V _{ILX}	Clock Input Low Voltage	OSCI	-	-	1.0	V
I _{CC1}	VDD operating supply current – Normal frequency operation mode	Freq. = 6MHz	-	-	10	mA
I _{CC2}	VDD operating supply current – Normal frequency operation mode	Freq. = 12MHz	-	-	20	mA
I _{CC3}	VDD operating supply current – Dual clock mode	Freq. = 256kHz	-	-	250	µA
I _{SB1}	Operating supply current 1 – Power down mode	WDT disabled	-	-	100	µA
GPIO Pins						
V _{IH}	Input High Voltage	Port 5 & Port 6 & Port 7 & Port 8 & Port 9	2.0	-	-	V
V _{IL}	Input Low Voltage	Port 5 & Port 6 & Port 7 & Port 8 & Port 9	-	-	0.8	V
I _{OH1}	Output High Voltage (P70~P73, P76 and P77)	I _{Sink} = 10.0mA V _{DD} = 5V	-	10	-	mA



Symbol	Parameter	Condition	Min	Type	Max	Unit
I _{OH2}	Output High Voltage (P74, P75)	I _{Sink} = 5.0mA V _{DD} = 5V	–	5	–	mA
I _{OH3}	Output High Voltage (Port 5 & Port 6 & Port 8 and P90~P93, P95, P96)	I _{Sink} = 10.0mA V _{REG} = 3.3V	–	10	–	mA
I _{OL1}	Output Low Voltage (P76 and P77 normal mode)	I _{Sink} = 10.0mA V _{DD} = 5V	–	10	–	mA
I _{OL2}	Output Low Voltage (P74, P75)	I _{Sink} = 10.0mA V _{DD} = 5V	–	5	–	mA
I _{OL3}	Output Low Voltage (P70~P73, P76 and P77 sink LED)	I _{Sink} = 10.0mA V _{DD} = 5V	–	10	–	mA
I _{OL4}	Output Low Voltage (P90 ~ P93, P95, P96 normal mode)	I _{Sink} = 10.0mA V _{REG} = 3.3V	–	10	–	mA
I _{OL5}	Output Low Voltage (P90 ~ P93, P95, P96 sink LED)	I _{Sink} = 10.0mA V _{REG} = 3.3V	–	10	–	mA
R _{PH1}	Pull-high resistor (Port 5, 6, 8, 9)	Input pin with pull-high resistor , V _{REG} = 3.3V	–	25	–	KΩ
R _{PH2}	Pull-high resistor(P.74 ~ P.77) (P74/P75) PS2 mode	Input pin with pull-high resistor , V _{DD} = 5V	–	2.2	–	KΩ
USB Interface						
V _{OH}	Static Output High	USB operation Mode	2.8	–	3.6	V
V _{OL}	Static Output Low		–	–	0.3	V
V _{DI}	Differential Input Sensitivity		0.2	–	–	V
V _{CM}	Differential Input Command Mode Range		0.8	–	2.5	V
V _{SE}	Single Ended Receiver Threshold		0.8	–	2.0	V
C _{IN}	Transceiver Capacitance		–	–	20	pF
V _{RG}	Output Voltage of Internal Regulator		3.0	–	3.6	V
R _{PH3}	Pull-high resistor (P.75 / D-)		–	1.5	–	KΩ

11 Application Circuit

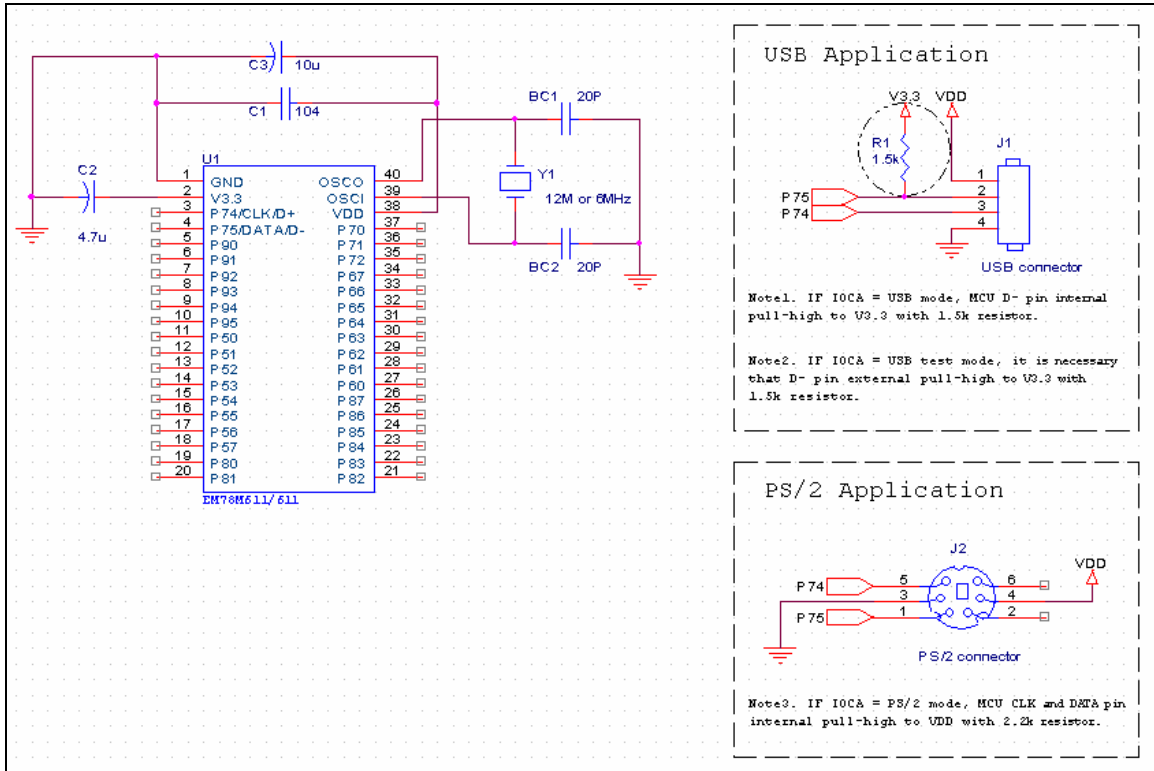

NOTE

A. BC1 , BC2 : load Capacitor

B. C1 (bypass capacitor) : that placed adjacent to V_{DD} pin , to minimize noise.

C. C2 , C3 (power capacitor) : that placed adjacent to the Power source , will improve transient response and ripple rejection.



APPENDIX

A Special Register Map

Operation Registers

Address	Name	Bit 7	Bit 6	Bit 5	Bit 4	Bit 3	Bit 2	Bit1	Bit 0	Default Value
0x00	R0	Indirect Addressing Register								0B_0000_0000
0x01	R1 (TCC)	Timer/Clock Counter								0B_0000_0000
0x02	R2 (PC)	Program Counter								0B_0000_0000
0x03	R3 (STATUS)	PS2	PS1	PS0	T	P	Z	DC	C	0B_0001_1xxx
0x04	R4 (RSR)	BK1	BK0	Select the register(Address: 00~3F) in indirect addressing mode						
0x05	R5 (Port 5)	P57	P56	P55	P54	P53	P52	P51	P50	0B_0000_0000
0x06	R 6 (Port 6)	P67	P66	P65	P64	P63	P62	P61	P60	0B_0000_0000
0x07	R 7 (Port 7)	P77	P76	P75/D- /DATA	P74/D+ /CLK	-	P72	P71	P70	0B_0000_u000
0x08	R8 (Port 8)	P87	P86	P85	P84	P83	P82	P81	P80	0B_0000_0000
0x09	R9 (Port 9)	-	P96	P95	-	P93	P92	P91	P90	0B_u00u_0000
0x0A	RA	-	-	-	-	-	EE_OK	EE_C1	EE_C0	0B_1111_1111
0x0B	RB	SE2.F	SE1.F	SR.2	SR.1	SR.0	DB2	DB1	DB0	0B_1111_1111
0x0C	RC	EP0_W	EP0_R	EP1_R	EP2_R	EP2_W	UDC_SUSPEND	UDC_Writing	STALL	0B_0000_0000
0x0D	RD	USB Application FIFO Address Register								0B_0000_0000
0x0E	RE	USB Application FIFO Data Register								0B_0000_0000
0x0F	RF	USB Host Resume_IF	SE1_IF	SE1_IF	Port 7 state change_1F	USB Reset_IF	USB Suspend_IF	EP0_IF	TCC_IF	0B_0000_0000



Control Registers

Address	Name	Bit 7	Bit 6	Bit 5	Bit 4	Bit 3	Bit 2	Bit 1	Bit 0	Default Value
	CONT	S7	INT	TSR2	SR1	TSR0	PSR2	PSR1	PSR0	0B_0011_1111
0x05	IOC5	Port 5 Direction Control Register								0B_1111_1111
0x06	IOC6	Port 6 Direction Control Register								0B_1111_1111
0x07	IOC7	Port 7 Direction Control Register								0B_1111_1111
0x08	IOC8	Port 8 Direction Control Register								0B_1111_1111
0x09	IOC9	Port 9 Direction Control Register								0B_1111_1111
0x0A	IOCA	Dual_Frq.1	Dual_Frq.0	-	Remote_Wake Up	ExReg_Sel	PDA	PS/2	USB	0B_11x0_0000
0x0B	IOCB	-	/P96	/P95	/P94	/P93	/P92	/P91	/P90	0B_x111_1111
0x0C	IOCC	-	P96	P95	-	P93	P92	P91	P90	0B_x00x_0000
0x0D	IOCD	-	/P96	/P95	-	/P93	/P92	/P91	/P90	0B_x00x_0000
0x0E	IOCE	/Dual clock	/WUE	WTE	RUN	Device_R esume	/PU8	/PU6	/PU5	0B_1101_0111
0x0F	IOCF	USB Host Resume_ IE	SE2_IE	SE1_IE	Port 7 state change_1F	USB Reset_IE	USB Suspend_ IE	EP0_IE	TCC_IE	0B_0000_0000

Extra Register (IOCA[3] = 1)

Address	Name	Bit 7	Bit 6	Bit 5	Bit 4	Bit 3	Bit 2	Bit 1	Bit 0	Default Value
0x0A	ERA	ADC	-	-	AD4	AD3	AD2	AD1	AD0	0B_0001_1111
0x0B	ERB	Digital Data (Bit 1~Bit 0)								0B_0000_0000
0x0C	ERC	Digital Data (Bit 10~Bit 2)								0B_0000_0000
0x0D	ERD	-	-	-	-	-	-	ADSP1	ADSP0	0B_0000_0000
0x0E	ERE	PEN2	PEN1	-	-	-	PS2	PS1	PS0	0B_0000_0001



B Instruction Set

Each instruction in the instruction set is a 13-bit word divided into an OP code and one or more operands. All instructions are executed within one single instruction cycle (consisting of two oscillator periods), unless the program counter is changed by-

- (a) Executing the instruction "MOV R2, A", "ADD R2,A", "TBL", or any other instructions that write to R2 (e.g. "SUB R2,A", "BS R2,6", "CLR R2", ...).
- (b) Execute CALL, RET, RETI, RETL, JMP, Conditional skip (JBS, JBC, JZ, JZA, DJZ, DJZA) which were tested to be true.

Under these cases, the execution takes two instruction cycles.

In addition, the instruction set has the following features:

- (1). Every bit of any register can be set, cleared, or tested directly.
- (2). The I/O register can be regarded as general register. That is, the same instruction can operate on I/O register.

Legend:

R = Register designator that specifies which one of the 64 registers (including operation and general purpose registers) is to be utilized by the instruction.

Bits 6 and 7 in R4 determine the selected register bank.

b = Bit field designator that selects the value for the bit located in the register R and which affects the operation.

k = 8 or 10-bit constant or literal value

Binary Instruction	Hex	Mnemonic	Operation	Status Affected
0 0000 0000 0000	0000	NOP	No Operation	None
0 0000 0000 0001	0001	DAA	Decimal Adjust A	C
0 0000 0000 0010	0002	CONTW	A → CONT	None
0 0000 0000 0011	0003	SLEP	0 → WDT, Stop oscillator	T, P
0 0000 0000 0100	0004	WDTC	0 → WDT	T, P
0 0000 0000 rrrr	000r	IOW R	A → IOCR	None ¹
0 0000 0001 0000	0010	ENI	Enable Interrupt	None
0 0000 0001 0001	0011	DISI	Disable Interrupt	None
0 0000 0001 0010	0012	RET	[Top of Stack] → PC	None
0 0000 0001 0011	0013	RETI	[Top of Stack] → PC, Enable Interrupt	None
0 0000 0001 0100	0014	CONTR	CONT → A	None
0 0000 0001 rrrr	001r	IOR R	IOCR → A	None ¹
0 0000 0010 0000	0020	TBL	R2+A → R2, Bits 8~9 of R2 unchanged	Z, C, DC
0 0000 01rr rrrr	00rr	MOV R,A	A → R	None
0 0000 1000 0000	0080	CLRA	0 → A	Z
0 0000 11rr rrrr	00rr	CLR R	0 → R	Z
0 0001 00rr rrrr	01rr	SUB A,R	R-A → A	Z, C, DC
0 0001 01rr rrrr	01rr	SUB R,A	R-A → R	Z, C, DC



Binary Instruction	Hex	Mnemonic	Operation	Status Affected
0 0001 10rr rrrr	01rr	DECA R	$R-1 \rightarrow A$	Z
0 0001 11rr rrrr	01rr	DEC R	$R-1 \rightarrow R$	Z
0 0010 00rr rrrr	02rr	OR A,R	$A \vee VR \rightarrow A$	Z
0 0010 01rr rrrr	02rr	OR R,A	$A \vee VR \rightarrow R$	Z
0 0010 10rr rrrr	02rr	AND A,R	$A \& R \rightarrow A$	Z
0 0010 11rr rrrr	02rr	AND R,A	$A \& R \rightarrow R$	Z
0 0011 00rr rrrr	03rr	XOR A,R	$A \oplus R \rightarrow A$	Z
0 0011 01rr rrrr	03rr	XOR R,A	$A \oplus R \rightarrow R$	Z
0 0011 10rr rrrr	03rr	ADD A,R	$A + R \rightarrow A$	Z, C, DC
0 0011 11rr rrrr	03rr	ADD R,A	$A + R \rightarrow R$	Z, C, DC
0 0100 00rr rrrr	04rr	MOV A,R	$R \rightarrow A$	Z
0 0100 01rr rrrr	04rr	MOV R,R	$R \rightarrow R$	Z
0 0100 10rr rrrr	04rr	COMA R	$\neg R \rightarrow A$	Z
0 0100 11rr rrrr	04rr	COM R	$\neg R \rightarrow R$	Z
0 0101 00rr rrrr	05rr	INCA R	$R+1 \rightarrow A$	Z
0 0101 01rr rrrr	05rr	INC R	$R+1 \rightarrow R$	Z
0 0101 10rr rrrr	05rr	DJZA R	$R-1 \rightarrow A$, skip if zero	None
0 0101 11rr rrrr	05rr	DJZ R	$R-1 \rightarrow R$, skip if zero	None
0 0110 00rr rrrr	06rr	RRCA R	$R(n) \rightarrow A(n-1)$, $R(0) \rightarrow C$, $C \rightarrow A(7)$	C
0 0110 01rr rrrr	06rr	RRC R	$R(n) \rightarrow R(n-1)$, $R(0) \rightarrow C$, $C \rightarrow R(7)$	C
0 0110 10rr rrrr	06rr	RLCA R	$R(n) \rightarrow A(n+1)$, $R(7) \rightarrow C$, $C \rightarrow A(0)$	C
0 0110 11rr rrrr	06rr	RLC R	$R(n) \rightarrow R(n+1)$, $R(7) \rightarrow C$, $C \rightarrow R(0)$	C
0 0111 00rr rrrr	07rr	SWAPA R	$R(0-3) \rightarrow A(4-7)$, $R(4-7) \rightarrow A(0-3)$	None
0 0111 01rr rrrr	07rr	SWAP R	$R(0-3) \leftrightarrow R(4-7)$	None
0 0111 10rr rrrr	07rr	JZA R	$R+1 \rightarrow A$, skip if zero	None
0 0111 11rr rrrr	07rr	JZ R	$R+1 \rightarrow R$, skip if zero	None
0 100b brrr rrrr	0xxx	BC R,b	$0 \rightarrow R(b)$	None ²
0 101b brrr rrrr	0xxx	BS R,b	$1 \rightarrow R(b)$	None
0 110b brrr rrrr	0xxx	JBC R,b	if $R(b)=0$, skip	None
0 111b brrr rrrr	0xxx	JBS R,b	if $R(b)=1$, skip	None
1 00kk kkkk kkkk	1kkk	CALL k	$PC+1 \rightarrow [SP]$, $(Page, k) \rightarrow PC$	None
1 01kk kkkk kkkk	1kkk	JMP k	$(Page, k) \rightarrow PC$	None
1 1000 kkkk kkkk	18kk	MOV A,k	$k \rightarrow A$	None
1 1001 kkkk kkkk	19kk	OR A,k	$A \vee k \rightarrow A$	Z
1 1010 kkkk kkkk	1Akk	AND A,k	$A \& k \rightarrow A$	Z
1 1011 kkkk kkkk	1Bkk	XOR A,k	$A \oplus k \rightarrow A$	Z
1 1100 kkkk kkkk	1Ckk	RETL k	$k \rightarrow A$, $[Top\ of\ Stack] \rightarrow PC$	None
1 1101 kkkk kkkk	1Dkk	SUB A,k	$k-A \rightarrow A$	Z, C, DC
1 1111 kkkk kkkk	1Fkk	ADD A,k	$k+A \rightarrow A$	Z, C, DC

Note: ¹ This instruction is applicable to IOCx only.

² This instruction is not recommended for RE, RF operation.



C Code Option Register

EM78M611E has two Code option registers, which are not part of the normal program memory. The option bits cannot be accessed during normal program execution.

Address 000:

Bit	12	11	10	9	8	7	6	5	4	3	2	1	0
Mnemonic	ID_8	ID_7	ID_6	ID_5	ID_4	ID_3	ID_2	ID_1	ID_0	OST_1	OST_0	Frequency	/Protect

Address 001:

Bit	5	4	3	2	1	0
Mnemonic	/AD_Hold	/R.S.	-	-	Package_1	Package_0

Bit	12	11	10	9	8	7	6
Mnemonic	QTP_Code1	QTP_Code0	EP2_ Maxsize_2	EP2_ Maxsize_1	EP2_ Maxsize_0	EP2_ DIR	EP2_ Enable

Address 000:

Bit 1 (Frequency) : Frequency Selection

0 : MCU run on 12 MHz

1 : MCU run on 6 MHz

Bits 3~2 (OST_1 ~ OST_0) : Oscillator start-up time.

00 : 500µs

01 : 2ms

10 : 8ms

11 : 16ms

Bits 4~12 : User ID

Address 001:

Bits 1~0 (Package_1 ~ Package_0) : Package type selection

00 : Not defined

01 : 40 pins

10 : Not defined

11 : 44 pins

Bits 3~2 : Reserved bits



Bit 4 (/R.S.) : D- Pull-up Resistance

0 : Connect Resistor Switch

1 : Disconnect Resistor Switch

Bit 5 (/AD_Hold) : Halts the MCU during AD conversion

0 : Halts the MCU during AD conversion

1 : MCU keeps running during AD conversion

Bit 6 (EP2_Enable) : Endpoint 2 Enable

0 : Disable

1 : Enable

Bit 7 (EP2_Dir) : Endpoint 2 Direction

0 : OUT

1 : IN

Bits 10~8 (EP2_Maxsize_2~0) : Endpoint 2 maximum size

000 : 1 Byte

001 : 2 Bytes

010 : 3 Bytes

011 : 4 Bytes

100 : 5 Byte

101 : 6 Bytes

110 : 7 Bytes

111 : 8 Bytes

Bits 12~11: Values are fixed