

## 3.2W Mono Class-D Audio Power Amplifier With 12-dB Gain and Auto Short-Circuit Recovery

Check for Samples: [TPA2039D1](#)

### FEATURES

- **Powerful Mono Class-D Speaker Amplifier**
  - 3.24 W (4 Ω, 5 V, 10% THDN)
  - 2.57 W (4 Ω, 5 V, 1% THDN)
  - 1.80 W (8 Ω, 5 V, 10% THDN)
  - 1.46 W (8 Ω, 5 V, 1% THDN)
- **+12 dB Fixed Gain**
- **Integrated Image Reject Filter for DAC Noise Reduction**
- **Low Output Noise of 27 μV**
- **Low Quiescent Current of 1.5 mA**
- **Differential Input Impedance of 150 kΩ**
- **Auto-Recovering Short-Circuit Protection**
- **Thermal-Overload Protection**
- **Filter-Free Mono Class-D Amp**
- **9-Ball 1,21 mm × 1,16 mm 0,4mm Pitch WCSP**

### APPLICATIONS

- **Wireless or Cellular Handsets and PDAs**
- **Portable Navigation Devices**
- **General Portable Audio Devices**

### DESCRIPTION

The TPA2039D1 is a 3.2 W high efficiency filter-free class-D audio power amplifier (class-D amp) with 12 dB of fixed gain in a tiny 1.21 mm x 1.16 mm wafer chip scale package (WCSP). The device requires only one external component.

Features like 93% efficiency, 1.5 mA quiescent current, 0.1 μA shutdown current, 82-dB PSRR, 27 μV output noise and improved RF immunity make the TPA2039D1 class-D amplifier ideal for cellular handsets. A fast start-up time of 4 ms with no audible pop makes the TPA2039D1 ideal for PDA and smart-phone applications.

### APPLICATION CIRCUIT

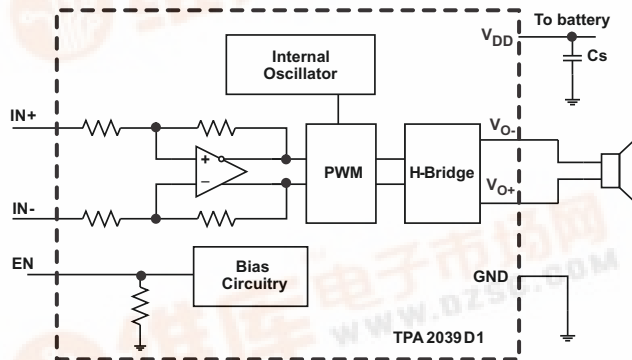

TPA2039D1  
 9-BALL 0.4mm PITCH  
 WAFER CHIP SCALE PACKAGE (YFF)  
 (TOP VIEW OF PCB)

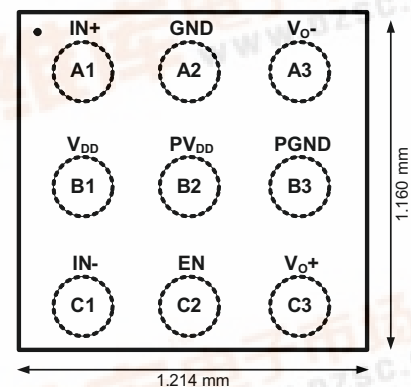

Please be aware that an important notice concerning availability, standard warranty, and use in critical applications of Texas Instruments semiconductor products and disclaimers thereto appears at the end of this data sheet.

PRODUCTION DATA information is current as of publication date. Products conform to specifications per the terms of the Texas Instruments standard warranty. Production processing does not necessarily include testing of all parameters.

Copyright © 2009–2010, Texas Instruments Incorporated



# TPA2039D1

SL00652A DECEMBER 2009 / REVISED JUNE 2010

[www.ti.com](http://www.ti.com)

These devices have limited built-in ESD protection. The leads should be shorted together or the device placed in conductive foam during storage or handling to prevent electrostatic damage to the MOS gates.

## ORDERING INFORMATION

$T_A$	PACKAGED DEVICES <sup>(1)</sup>	PART NUMBER <sup>(2)</sup>	SYMBOL
-40°C to 85°C	9-ball WSCP	TPA2039D1YFFR	DAR
		TPA2039D1YFFT	DAR

- (1) For the most current package and ordering information, see the Package Option Addendum at the end of this document, or see the TI Web site at [www.ti.com](http://www.ti.com)
- (2) The YFF package is only available taped and reeled. The suffix "R" indicates a reel of 3000, the suffix "T" indicates a reel of 250.

## ABSOLUTE MAXIMUM RATINGS

over operating free-air temperature range,  $T_A = 25^\circ\text{C}$  (unless otherwise noted)<sup>(1)</sup>

		VALUE	UNIT	
$V_{DD}, PV_{DD}$	Supply voltage	In active mode	-0.3 to 6.0	V
		In shutdown mode	-0.3 to 6.0	V
$V_I$	Input voltage	EN, IN+, IN-	-0.3 to $V_{DD} + 0.3$	V
$R_L$	Minimum load resistance	3.2	$\Omega$	
	Output continuous total power dissipation	See Dissipation Rating Table		
$T_A$	Operating free-air temperature range	-40 to 85	$^\circ\text{C}$	
$T_J$	Operating junction temperature range	-40 to 150	$^\circ\text{C}$	
$T_{stg}$	Storage temperature range	-65 to 85	$^\circ\text{C}$	

- (1) Stresses beyond those listed under *absolute maximum ratings* may cause permanent damage to the device. These are stress ratings only, and functional operation of the device at these or any other conditions beyond those indicated under *recommended operating conditions* is not implied. Exposure to Absolute Maximum Ratings conditions for extended periods may affect device reliability.

## DISSIPATION RATINGS

PACKAGE	DERATING FACTOR <sup>(1)</sup>	$T_A < 25^\circ\text{C}$	$T_A = 70^\circ\text{C}$	$T_A = 85^\circ\text{C}$
YFF (WCSP)	4.2 mW/ $^\circ\text{C}$	525 mW	336 mW	273 mW

- (1) Derating factor measure with high K board.

## RECOMMENDED OPERATING CONDITIONS

		MIN	MAX	UNIT
$V_{DD}, PV_{DD}$	Class-D supply voltage	2.5	5.5	V
$V_{IH}$	High-level input voltage	EN	1.3	V
$V_{IL}$	Low-level input voltage	EN	0.35	V
$V_{IC}$	Common mode input voltage range	$V_{DD} = 2.5\text{V}, 5.5\text{V}, \text{CMRR} \geq 49 \text{ dB}$		V
$T_A$	Operating free-air temperature	-40	85	$^\circ\text{C}$

**ELECTRICAL CHARACTERISTICS**
 $T_A = 25^\circ\text{C}$  (unless otherwise noted)

PARAMETER		TEST CONDITIONS	MIN	TYP	MAX	UNIT
$ V_{OS} $	Output offset voltage (measured differentially)	$V_I = 0\text{ V}$ , $V_{DD} = 2.5\text{ V to }5.5\text{ V}$		1	10	mV
$ I_{IH} $	High-level EN input current	$V_{DD} = 5.5\text{ V}$ , $V_{EN} = 5.5\text{ V}$			50	$\mu\text{A}$
$ I_{IL} $	Low-level EN input current	$V_{DD} = 5.5\text{ V}$ , $V_{EN} = 0\text{ V}$			1	$\mu\text{A}$
$I_{(Q)}$	Quiescent current	$V_{DD} = 5.5\text{ V}$ , no load		1.8	2.5	mA
		$V_{DD} = 3.6\text{ V}$ , no load		1.5	2.3	
		$V_{DD} = 2.5\text{ V}$ , no load		1.3	2.1	
$I_{(SD)}$	Shutdown current	$V_{EN} = 0.35\text{ V}$ , $V_{DD} = 3.6\text{ V}$		0.1	2	$\mu\text{A}$
$R_{O, SD}$	Output impedance in shutdown mode	$V_{EN} = 0.35\text{ V}$		2		k $\Omega$
$f_{(SW)}$	Switching frequency	$V_{DD} = 2.5\text{ V to }5.5\text{ V}$	250	300	350	kHz
$A_V$	Gain	$V_{DD} = 2.5\text{ V to }5.5\text{ V}$ , $R_L = \text{no load}$	11.5	12	12.5	dB
$R_{EN}$	Resistance from EN to GND			300		k $\Omega$
$R_{IN}$	Single ended input resistance	$V_{EN} \geq V_{IH}$		75		k $\Omega$
		$V_{EN} \leq V_{IL}$		75		

**OPERATING CHARACTERISTICS**
 $V_{DD} = 3.6\text{ V}$ ,  $T_A = 25^\circ\text{C}$ ,  $R_L = 8\ \Omega$  (unless otherwise noted)

PARAMETER		TEST CONDITIONS	MIN	TYP	MAX	UNIT
$P_O$	Output power	THD + N = 10%, $f = 1\text{ kHz}$ , $R_L = 4\ \Omega$	$V_{DD} = 5\text{ V}$		3.24	W
			$V_{DD} = 3.6\text{ V}$		1.62	
			$V_{DD} = 2.5\text{ V}$		0.70	
		THD + N = 1%, $f = 1\text{ kHz}$ , $R_L = 4\ \Omega$	$V_{DD} = 5\text{ V}$		2.57	W
			$V_{DD} = 3.6\text{ V}$		1.32	
			$V_{DD} = 2.5\text{ V}$		0.57	
		THD + N = 10%, $f = 1\text{ kHz}$ , $R_L = 8\ \Omega$	$V_{DD} = 5\text{ V}$		1.80	W
			$V_{DD} = 3.6\text{ V}$		0.91	
			$V_{DD} = 2.5\text{ V}$		0.42	
		THD + N = 1%, $f = 1\text{ kHz}$ , $R_L = 8\ \Omega$	$V_{DD} = 5\text{ V}$		1.46	W
			$V_{DD} = 3.6\text{ V}$		0.74	
			$V_{DD} = 2.5\text{ V}$		0.33	
$V_n$	Noise output voltage	$V_{DD} = 3.6\text{ V}$ , Inputs AC grounded with $C_1 = 2\ \mu\text{F}$ , $f = 20\text{ Hz to }20\text{ kHz}$	A-weighting		27	$\mu\text{V}_{RMS}$
			No weighting		36	
THD+N	Total harmonic distortion plus noise	$V_{DD} = 5.0\text{ V}$ , $P_O = 1.0\text{ W}$ , $f = 1\text{ kHz}$ , $R_L = 8\ \Omega$		0.12%		
		$V_{DD} = 3.6\text{ V}$ , $P_O = 0.5\text{ W}$ , $f = 1\text{ kHz}$ , $R_L = 8\ \Omega$		0.05%		
		$V_{DD} = 2.5\text{ V}$ , $P_O = 0.2\text{ W}$ , $f = 1\text{ kHz}$ , $R_L = 8\ \Omega$		0.05%		
		$V_{DD} = 5.0\text{ V}$ , $P_O = 2.0\text{ W}$ , $f = 1\text{ kHz}$ , $R_L = 4\ \Omega$		0.32%		
		$V_{DD} = 3.6\text{ V}$ , $P_O = 1.0\text{ W}$ , $f = 1\text{ kHz}$ , $R_L = 4\ \Omega$		0.11%		
		$V_{DD} = 2.5\text{ V}$ , $P_O = 0.4\text{ W}$ , $f = 1\text{ kHz}$ , $R_L = 4\ \Omega$		0.12%		
PSRR	AC power supply rejection ratio	$V_{DD} = 3.6\text{ V}$ , Inputs AC grounded with $C_1 = 2\ \mu\text{F}$ , $200\text{ mV}_{pp}$ ripple, $f = 217\text{ Hz}$		82	dB	
CMRR	Common mode rejection ratio	$V_{DD} = 3.6\text{ V}$ , $V_{IC} = 1\text{ V}_{PP}$ , $f = 217\text{ Hz}$		77	dB	
$T_{SU}$	Startup time from shutdown	$V_{DD} = 3.6\text{ V}$		4	ms	

# TPA2039D1

SL00652A DECEMBER 2009 / REVISED JUNE 2010

[www.ti.com](http://www.ti.com)

## OPERATING CHARACTERISTICS (continued)

 $V_{DD} = 3.6\text{ V}$ ,  $T_A = 25^\circ\text{C}$ ,  $R_L = 8\ \Omega$  (unless otherwise noted)

PARAMETER	TEST CONDITIONS	MIN	TYP	MAX	UNIT
$I_{SC}$	Short circuit protection threshold	$V_{DD} = 3.6\text{ V}$ , $V_{O+}$ shorted to $V_{DD}$		2	A
		$V_{DD} = 3.6\text{ V}$ , $V_{O-}$ shorted to $V_{DD}$		2	
		$V_{DD} = 3.6\text{ V}$ , $V_{O+}$ shorted to GND		2	
		$V_{DD} = 3.6\text{ V}$ , $V_{O-}$ shorted to GND		2	
		$V_{DD} = 3.6\text{ V}$ , $V_{O+}$ shorted to $V_{O-}$		2	
$T_{AR}$	Time for which output is disabled after a short circuit event, after which auto-recovery trials are continuously made	$V_{DD} = 2.5\text{ V to }5.5\text{ V}$		100	ms

## Terminal Functions

TERMINAL		I/O	DESCRIPTION
NAME	WCSP BALL		
IN-	C1	I	Negative differential audio input.
IN+	A1	I	Positive differential audio input.
$V_{O-}$	A3	O	Negative BTL audio output.
$V_{O+}$	C3	O	Positive BTL audio output.
GND	A2	I	Analog ground terminal. Must be connected to same potential as PGND using a direct connection to a single point ground.
PGND	B3	I	High-current Analog ground terminal. Must be connected to same potential as GND using a direct connection to a single point ground.
$V_{DD}$	B1	I	Power supply terminal. Must be connected to same power supply as $PV_{DD}$ using a direct connection. Voltage must be within values listed in Recommended Operating Conditions table.
$PV_{DD}$	B2	I	High-current Power supply terminal. Must be connected to same power supply as $V_{DD}$ using a direct connection. Voltage must be within values listed in Recommended Operating Conditions table.
EN	C2	I	Enable terminal. Connect to Logic High voltage to enable device, Logic Low voltage to disable (shutdown).

## FUNCTIONAL BLOCK DIAGRAM

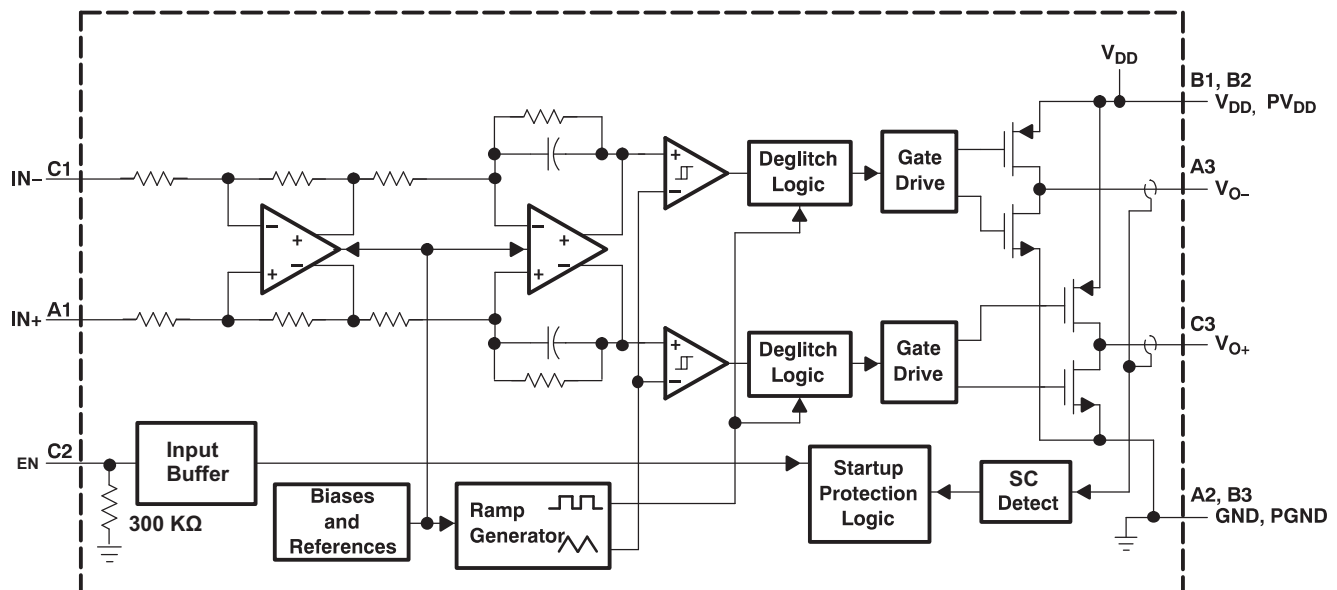

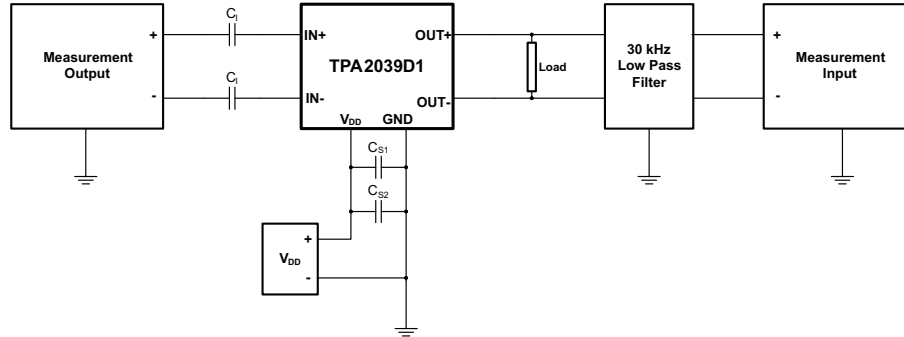
**TEST SETUP FOR GRAPHS**

1.  $C_1$  was shorted for any common-mode input voltage measurement. All other measurements were taken with  $C_1 = 0.1\text{-}\mu\text{F}$  (unless otherwise noted).
2.  $C_{S1} = 0.1\text{-}\mu\text{F}$  is placed very close to the device. The optional  $C_{S2} = 10\text{-}\mu\text{F}$  is used for datasheet graphs.
3. The 30-kHz low-pass filter is required even if the analyzer has an internal low-pass filter. An RC low-pass filter (1k $\Omega$ , 4700pF) is used on each output for the data sheet graphs.

TYPICAL CHARACTERISTICS

$V_{DD} = 3.6\text{ V}$ ,  $C_1 = 0.1\ \mu\text{F}$ ,  $C_{S1} = 0.1\ \mu\text{F}$ ,  $C_{S2} = 10\ \mu\text{F}$ ,  $T_A = 25^\circ\text{C}$ ,  $R_L = 8\ \Omega$  (unless otherwise noted)

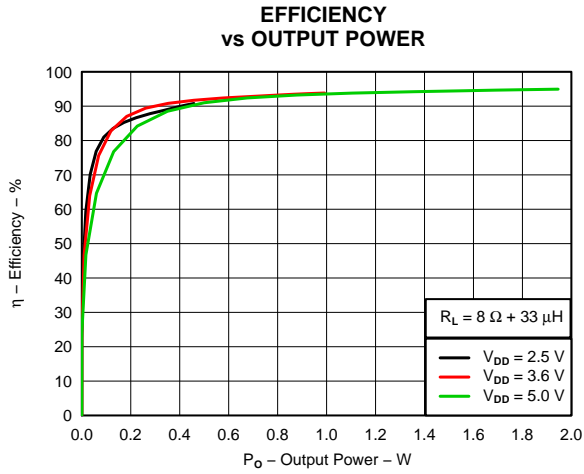

Figure 1.

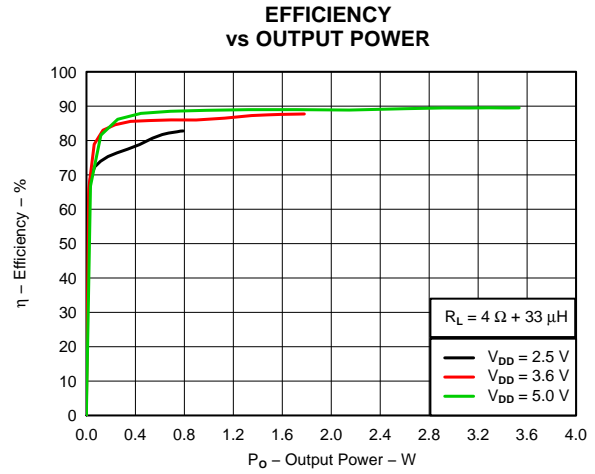

Figure 2.

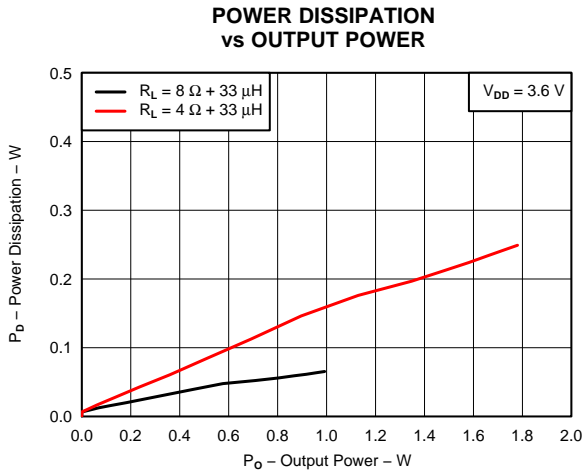

Figure 3.

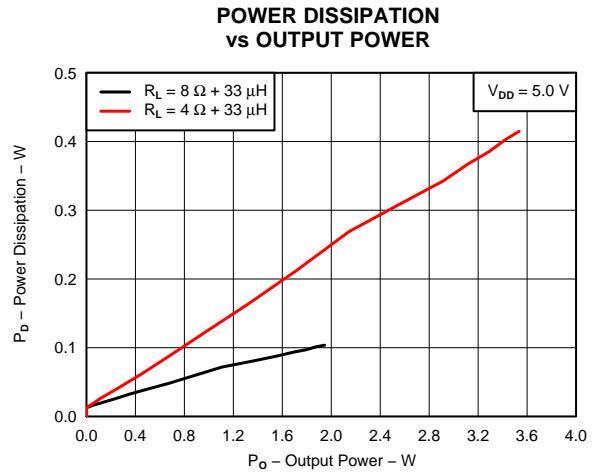

Figure 4.

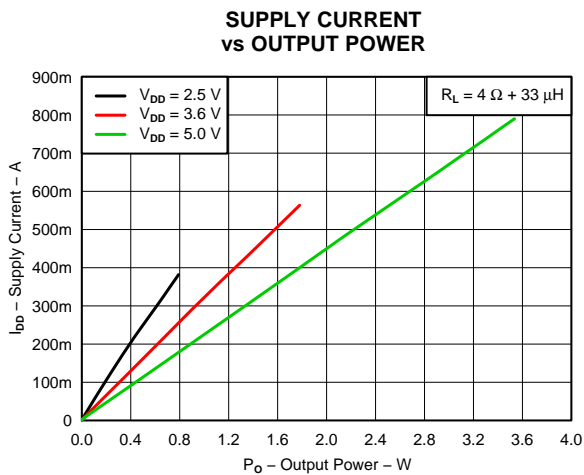

Figure 5.

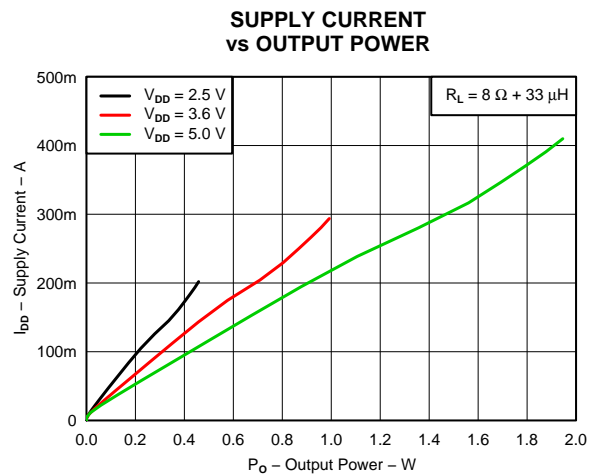

Figure 6.

TYPICAL CHARACTERISTICS (continued)

$V_{DD} = 3.6\text{ V}$ ,  $C_1 = 0.1\ \mu\text{F}$ ,  $C_{S1} = 0.1\ \mu\text{F}$ ,  $C_{S2} = 10\ \mu\text{F}$ ,  $T_A = 25^\circ\text{C}$ ,  $R_L = 8\ \Omega$  (unless otherwise noted)

SUPPLY CURRENT vs SUPPLY VOLTAGE

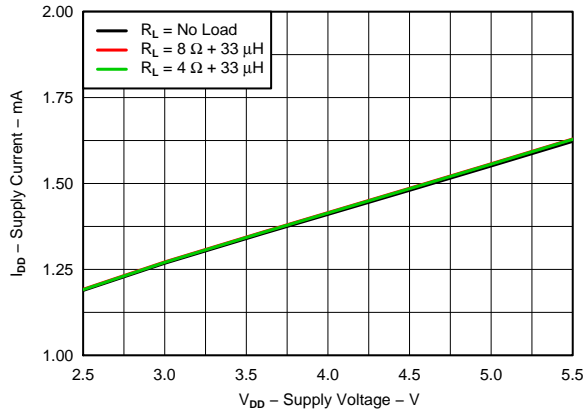

Figure 7.

SUPPLY CURRENT vs EN VOLTAGE

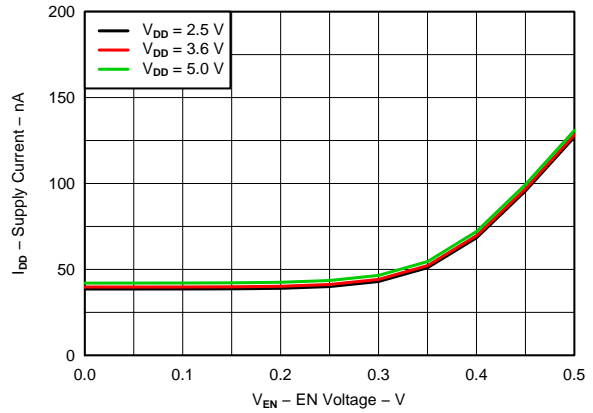

Figure 8.

OUTPUT POWER vs LOAD RESISTANCE

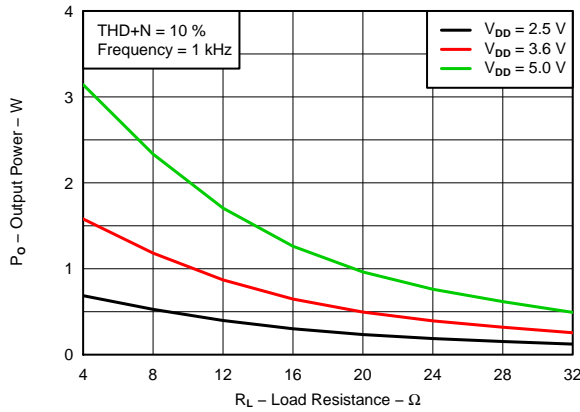

Figure 9.

OUTPUT POWER vs LOAD RESISTANCE

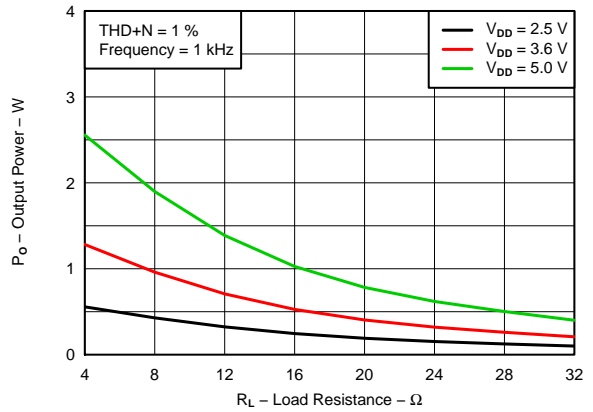

Figure 10.

OUTPUT POWER vs SUPPLY VOLTAGE

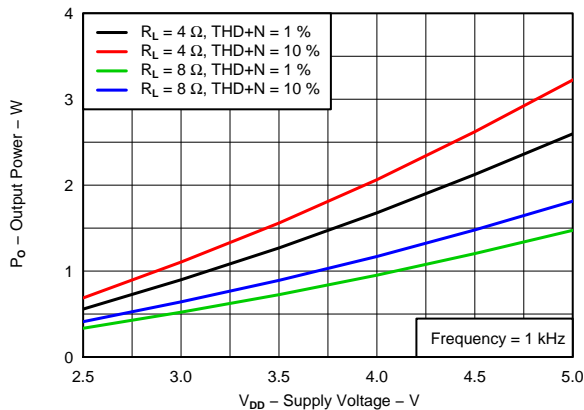

Figure 11.

THD + NOISE vs OUTPUT POWER

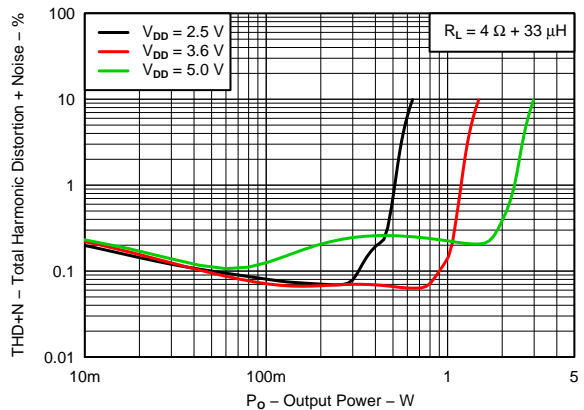

Figure 12.

TYPICAL CHARACTERISTICS (continued)

$V_{DD} = 3.6\text{ V}$ ,  $C_1 = 0.1\ \mu\text{F}$ ,  $C_{S1} = 0.1\ \mu\text{F}$ ,  $C_{S2} = 10\ \mu\text{F}$ ,  $T_A = 25^\circ\text{C}$ ,  $R_L = 8\ \Omega$  (unless otherwise noted)

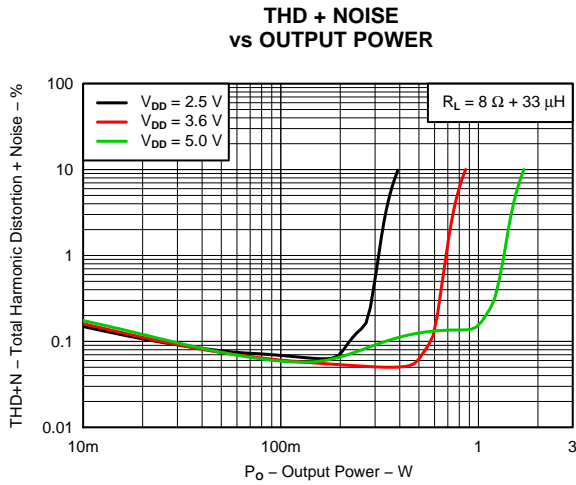

Figure 13.

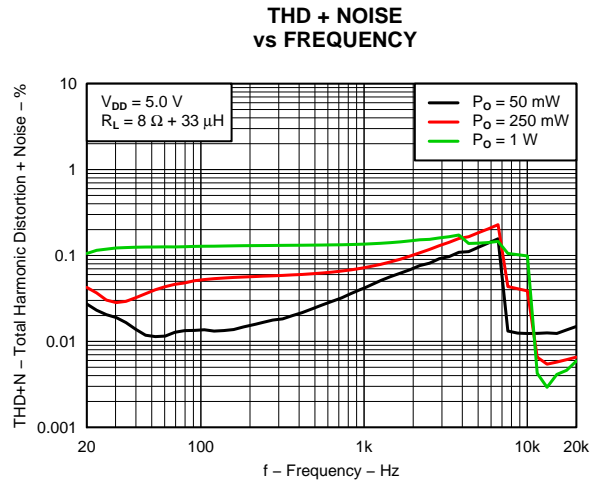

Figure 14.

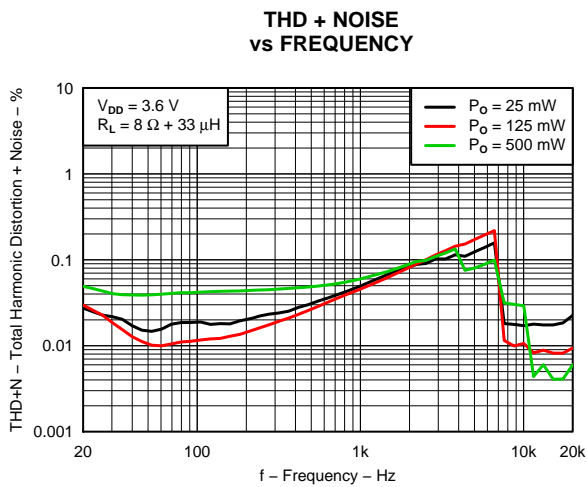

Figure 15.

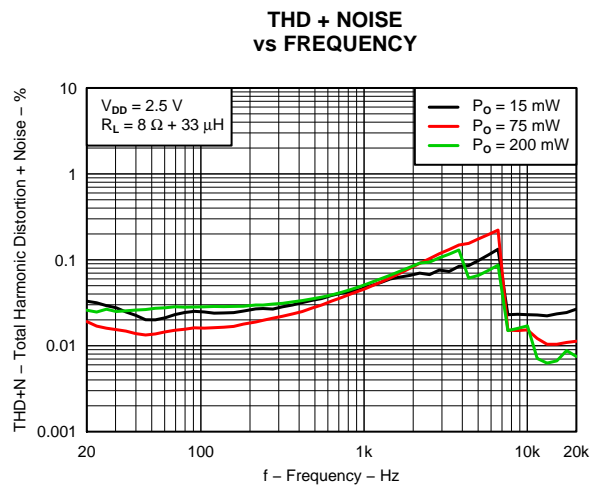

Figure 16.

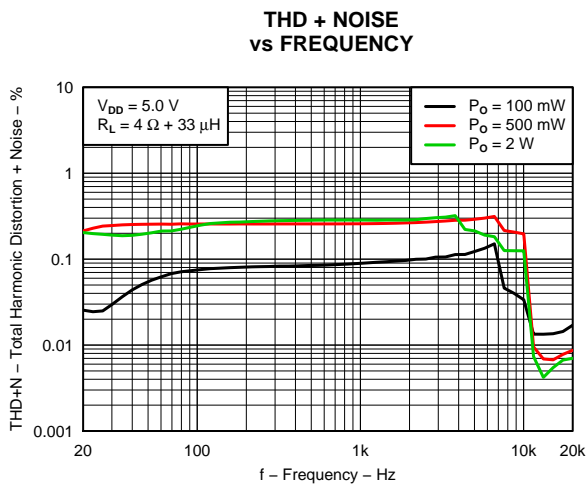

Figure 17.

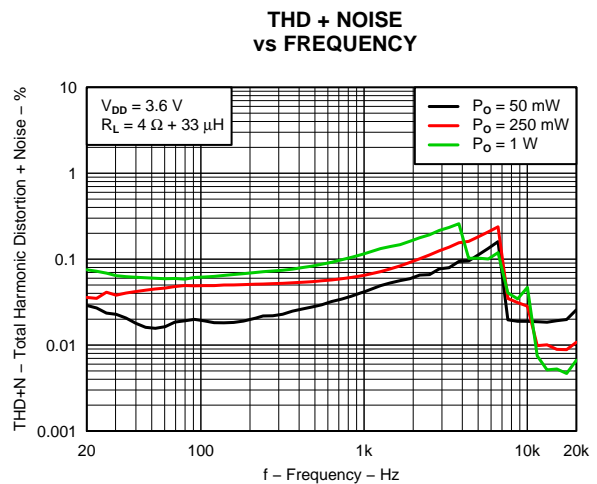

Figure 18.



TYPICAL CHARACTERISTICS (continued)

$V_{DD} = 3.6\text{ V}$ ,  $C_1 = 0.1\ \mu\text{F}$ ,  $C_{S1} = 0.1\ \mu\text{F}$ ,  $C_{S2} = 10\ \mu\text{F}$ ,  $T_A = 25^\circ\text{C}$ ,  $R_L = 8\ \Omega$  (unless otherwise noted)

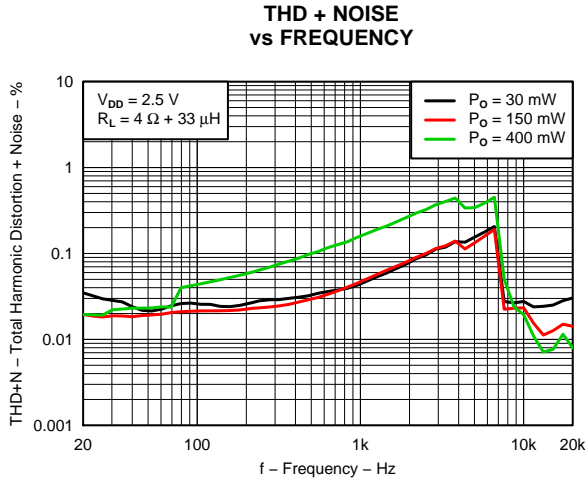

Figure 19.

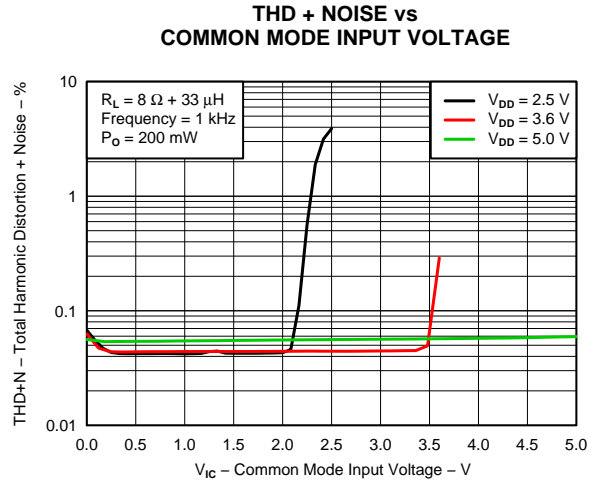

Figure 20.

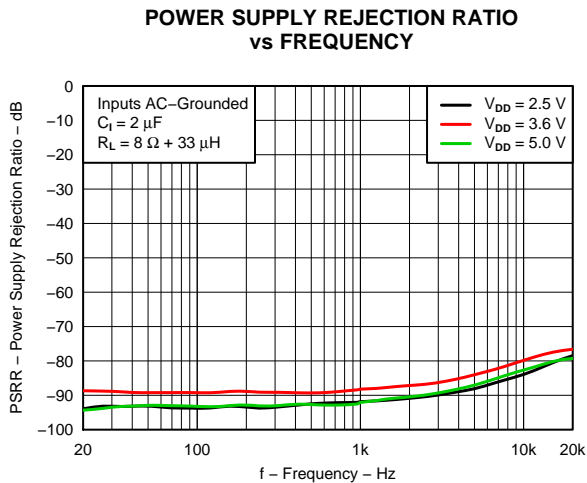

Figure 21.

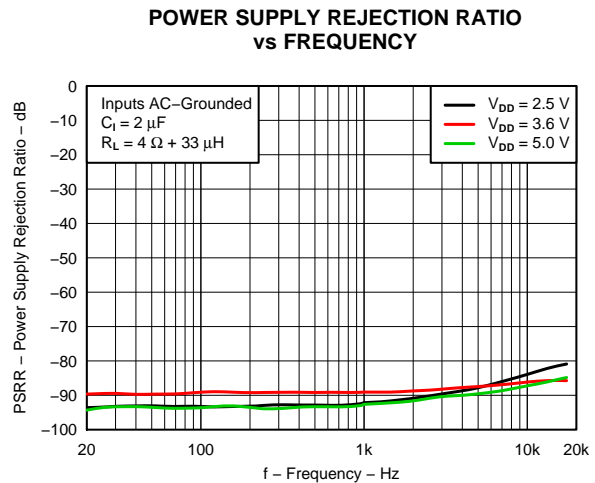

Figure 22.

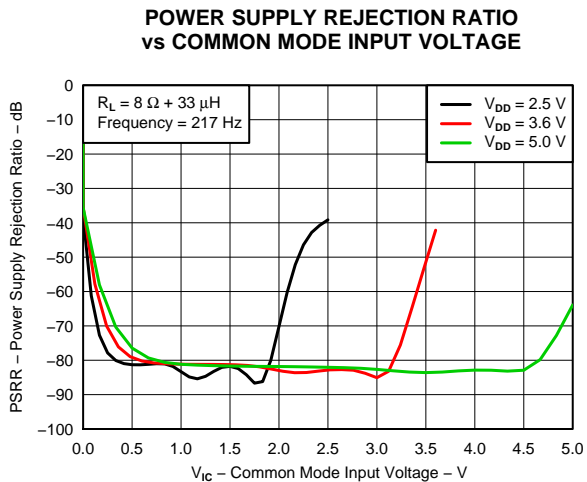

Figure 23.

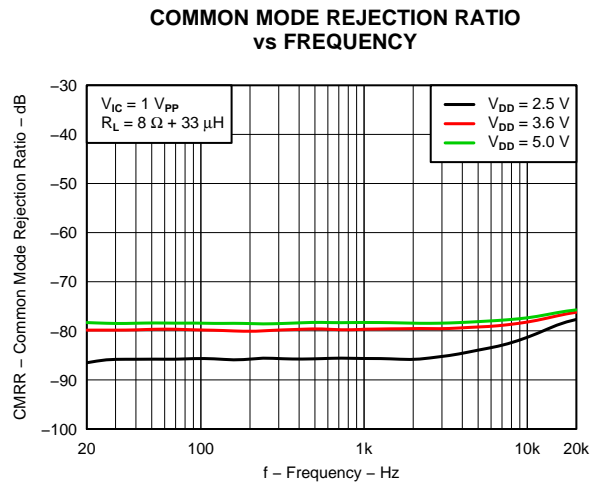
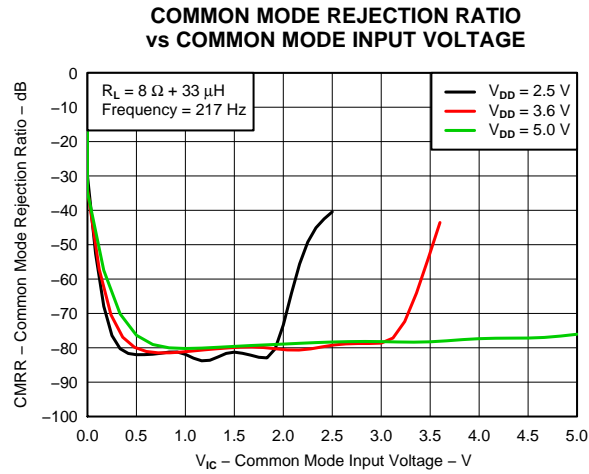

Figure 24.

TYPICAL CHARACTERISTICS (continued)

$V_{DD} = 3.6\text{ V}$ ,  $C_1 = 0.1\ \mu\text{F}$ ,  $C_{S1} = 0.1\ \mu\text{F}$ ,  $C_{S2} = 10\ \mu\text{F}$ ,  $T_A = 25^\circ\text{C}$ ,  $R_L = 8\ \Omega$  (unless otherwise noted)



**GSM POWER SUPPLY REJECTION  
vs TIME**

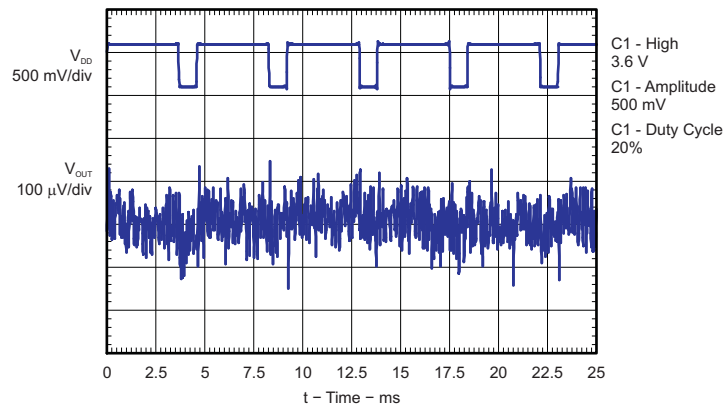

**GSM POWER SUPPLY REJECTION  
vs FREQUENCY**

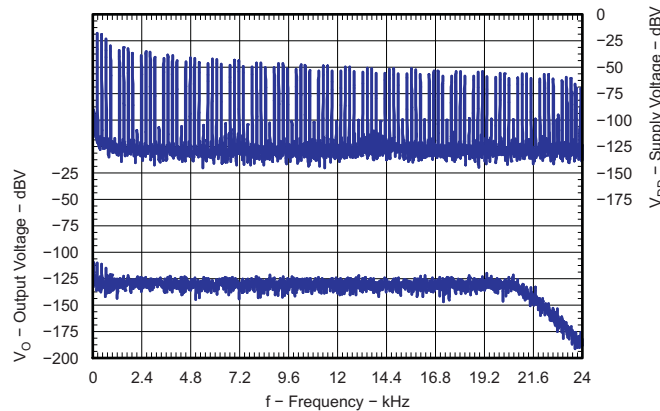

## APPLICATION INFORMATION

### SHORT CIRCUIT AUTO-RECOVERY

When a short-circuit event occurs, the TPA2039D1 goes to shutdown mode and activates the integrated auto-recovery process whose aim is to return the device to normal operation once the short-circuit is removed. This process repeatedly examines (once every 100ms) whether the short-circuit condition persists, and returns the device to normal operation immediately after the short-circuit condition is removed. This feature helps protect the device from large currents and maintain a good long-term reliability.

### INTEGRATED IMAGE REJECT FILTER FOR DAC NOISE REJECTION

In applications which use a DAC to drive Class-D amplifiers, out-of-band noise energy present at the DAC's image frequencies fold back into the audio-band at the output of the Class-D amplifier. An external low-pass filter is often placed between the DAC and the Class-D amplifier in order to attenuate this noise.

The TPA2039D1 has an integrated Image Reject Filter with a low-pass cutoff frequency of 130 kHz, which significantly attenuates this noise. Depending on the system noise specification, the integrated Image Reject Filter may help eliminate external filtering, thereby saving board space and component cost.

### COMPONENT SELECTION

Figure 28 shows the TPA2039D1 typical schematic with differential inputs, while Figure 29 shows the TPA2039D1 with differential inputs and input capacitors. Figure 30 shows the TPA2039D1 with a single-ended input.

#### Decoupling Capacitors ( $C_{S1}$ , $C_{S2}$ )

The TPA2039D1 is a high-performance class-D audio amplifier that requires adequate power supply decoupling to ensure the efficiency is high and total harmonic distortion (THD) is low. For higher frequency transients, spikes, or digital hash on the line, a good low equivalent-series-resistance (ESR) ceramic capacitor  $C_{S1} = 0.1\mu\text{F}$ , placed as close as possible to the device  $V_{DD}$  lead works best. Placing  $C_{S1}$  close to the TPA2039D1 is important for the efficiency of the class-D amplifier, because any resistance or inductance in the trace between the device and the capacitor can cause a loss in efficiency. For filtering lower-frequency noise signals, a  $10\mu\text{F}$  or greater capacitor ( $C_{S2}$ ) placed near the audio power amplifier would also help, but it is not required in most applications because of the high PSRR of this device. Typically, the smaller the capacitor's case size, the lower the inductance and the closer it can be placed to the TPA2039D1. X5R and X7R dielectric capacitors are recommended for both  $C_{S1}$  and  $C_{S2}$ .

#### Input Capacitors ( $C_I$ )

The TPA2039D1 does not require input coupling capacitors if the design uses a differential source that is biased within the common-mode input voltage range. That voltage range is listed in the Recommended Operating Conditions table. If the input signal is not biased within the recommended common-mode input range, such as in needing to use the input as a high pass filter, shown in Figure 29, or if using a single-ended source, shown in Figure 30, input coupling capacitors are required. The same value capacitors should be used on both IN+ and IN– for best pop performance. The 3-dB high-pass cutoff frequency  $f_C$  of the filter formed by the input coupling capacitor  $C_I$  and the input resistance  $R_I$  (typically 75 k $\Omega$ ) of the TPA2039D1 is given by Equation 1:

$$f_C = \frac{1}{(2\pi R_I C_I)} \quad (1)$$

The value of the input capacitor is important to consider as it directly affects the bass (low frequency) performance of the circuit. Speaker response may also be taken into consideration when setting the corner frequency using input capacitors. Solving for the input coupling capacitance, we get:

$$C_I = \frac{1}{(2\pi R_I f_C)} \quad (2)$$

If the corner frequency is within the audio band, the capacitors should have a tolerance of  $\pm 10\%$  or better, because any mismatch in capacitance causes an impedance mismatch at the corner frequency and below.

# TPA2039D1

SL00652A DECEMBER 2009 / REVISED JUNE 2010

[www.ti.com](http://www.ti.com)

For a flat low-frequency response, use large input coupling capacitors (0.1  $\mu\text{F}$  or larger). X5R and X7R dielectric capacitors are recommended.

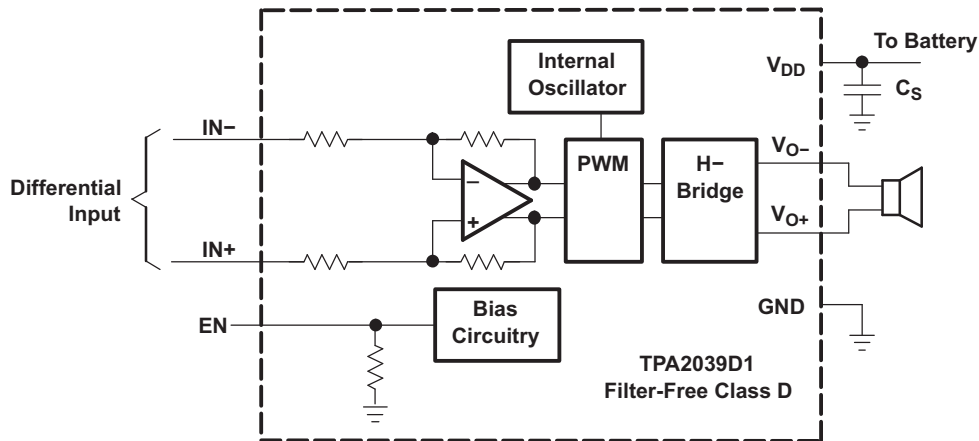

**Figure 28. Typical TPA2039D1 Application Schematic With DC-coupled Differential Input**

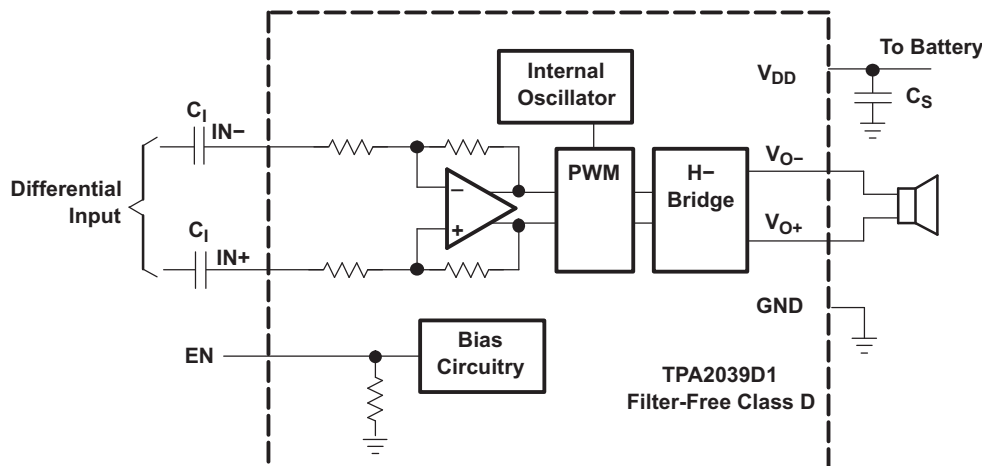

**Figure 29. TPA2039D1 Application Schematic With Differential Input and Input Capacitors**

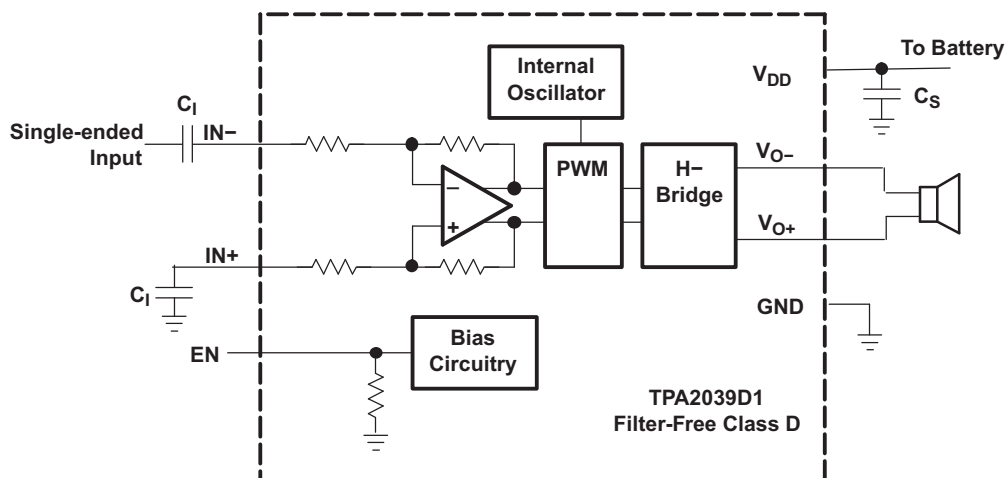

**Figure 30. TPA2039D1 Application Schematic With Single-Ended Input**

## EFFICIENCY AND THERMAL INFORMATION

The maximum ambient operating temperature of the TPA2039D1 depends on the load resistance, power supply voltage and heat-sinking ability of the PCB system. The derating factor for the YFF package is shown in the dissipation rating table. Converting this to  $\theta_{JA}$ :

$$\theta_{JA} = \frac{1}{\text{Derating Factor}} \quad (3)$$

Given  $\theta_{JA}$  (from the Package Dissipation ratings table), the maximum allowable junction temperature (from the Absolute Maximum ratings table), and the maximum internal dissipation (from Power Dissipation vs Output Power figures) the maximum ambient temperature can be calculated with the following equation. Note that the units on these figures are Watts RMS. Because of crest factor (ratio of peak power to RMS power) from 9–15 dB, thermal limitations are not usually encountered.

$$T_{A\text{Max}} = T_{J\text{Max}} - \theta_{JA} P_{D\text{max}} \quad (4)$$

The TPA2039D1 is designed with thermal protection that turns the device off when the junction temperature surpasses 150°C to prevent damage to the IC. Note that the use of speakers less resistive than 4-Ω (typ) is not advisable. Below 4-Ω (typ) the thermal performance of the device dramatically reduces because of increased output current and reduced amplifier efficiency. The Absolute Maximum rating of 3.2-Ω covers the manufacturing tolerance of a 4-Ω speaker and speaker impedance decrease due to frequency.  $\theta_{JA}$  is a gross approximation of the complex thermal transfer mechanisms between the device and its ambient environment. If the  $\theta_{JA}$  calculation reveals a potential problem, a more accurate estimate should be made.

## WHEN TO USE AN OUTPUT FILTER

Design the TPA2039D1 without an Inductor / Capacitor (LC) output filter if the traces from the amplifier to the speaker are short. Wireless handsets and PDAs are great applications for this class-D amplifier to be used without an output filter.

The TPA2039D1 does not require an LC output filter for short speaker connections (approximately 100 mm long or less). A ferrite bead can often be used in the design if failing radiated emissions testing without an LC filter; and, the frequency-sensitive circuit is greater than 1 MHz. If choosing a ferrite bead, choose one with high impedance at high frequencies, but very low impedance at low frequencies. The selection must also take into account the currents flowing through the ferrite bead. Ferrites can begin to lose effectiveness at much lower than rated current values. See the TPA2039D1 EVM User's Guide for components used successfully by TI.

Figure 31 shows a typical ferrite-bead output filter.

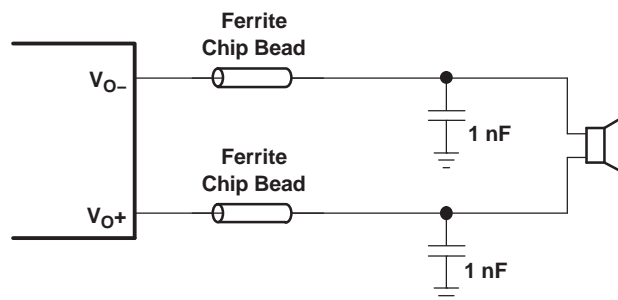
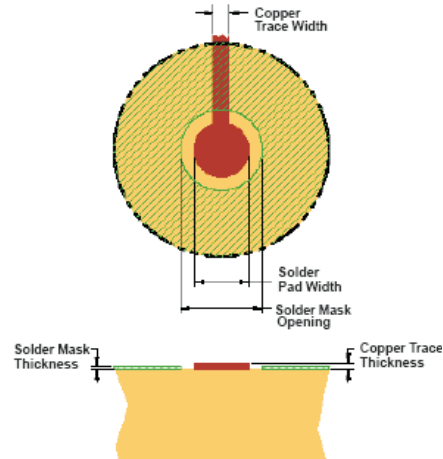

Figure 31. Typical Ferrite Chip Bead Filter

## PRINTED CIRCUIT BOARD LAYOUT

In making the pad size for the WCSP balls, it is recommended that the layout use nonsolder mask defined (NSMD) land. With this method, the solder mask opening is made larger than the desired land area, and the opening size is defined by the copper pad width. [Figure 32](#) shows the appropriate diameters for a WCSP layout.



**Figure 32. Land Pattern Image and Dimensions**

SOLDER PAD DEFINITIONS	COPPER PAD	SOLDER MASK OPENING <sup>(5)</sup>	COPPER THICKNESS	STENCIL OPENING <sup>(6)(7)</sup>	STENCIL THICKNESS
Nonsolder mask defined (NSMD)	0.23 mm	0.310 mm	1 oz max (0.032 mm)	0.275 mm x 0.275 mm Sq. (rounded corners)	0.1 mm thick

1. Circuit traces from NSMD defined PWB lands should be 75  $\mu\text{m}$  to 100  $\mu\text{m}$  wide in the exposed area inside the solder mask opening. Wider trace widths reduce device stand off and impact reliability.
2. Best reliability results are achieved when the PWB laminate glass transition temperature is above the operating the range of the intended application.
3. Recommend solder paste is Type 3 or Type 4.
4. For a PWB using a Ni/Au surface finish, the gold thickness should be less 0.5  $\mu\text{m}$  to avoid a reduction in thermal fatigue performance.
5. Solder mask thickness should be less than 20  $\mu\text{m}$  on top of the copper circuit pattern
6. Best solder stencil performance is achieved using laser cut stencils with electro polishing. Use of chemically etched stencils give inferior solder paste volume control.
7. Trace routing away from WCSP device should be balanced in X and Y directions to avoid unintentional component movement due to solder wetting forces.

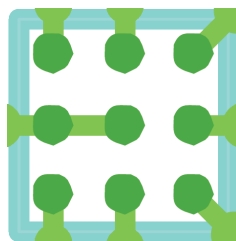

**Figure 33. Layout Snapshot**

An on-pad via is not required to route the middle ball B2 ( $PV_{DD}$ ) of the TPA2039D1. Just short ball B2 ( $PV_{DD}$ ) to ball B1 ( $V_{DD}$ ) and connect both to the supply trace as shown in [Figure 33](#). This simplifies board routing and saves manufacturing cost.

**Package Dimensions**

D	E
Max = 1190µm	Max = 1244µm
Min = 1130µm	Min = 1184µm

**REVISION HISTORY**

**Changes from Original (December 2009) to Revision A**

**Page**

- Changed the Package Dimensions table. D was Max = 1244µm, Min = 1184µm. E was Max = 1190µm, Min = 1130µm ..... [15](#)



www.ti.com

PACKAG

## PACKAGING INFORMATION

Orderable Device	Status <sup>(1)</sup>	Package Type	Package Drawing	Pins	Package Qty	Eco Plan <sup>(2)</sup>	Lead/Ball Finish	MSL Peak Temp
TPA2039D1YFFR	ACTIVE	DSBGA	YFF	9	3000	Green (RoHS & no Sb/Br)	SNAGCU	Level-1-260C
TPA2039D1YFFT	ACTIVE	DSBGA	YFF	9	250	Green (RoHS & no Sb/Br)	SNAGCU	Level-1-260C

<sup>(1)</sup> The marketing status values are defined as follows:

**ACTIVE:** Product device recommended for new designs.

**LIFEBUY:** TI has announced that the device will be discontinued, and a lifetime-buy period is in effect.

**NRND:** Not recommended for new designs. Device is in production to support existing customers, but TI does not recommend using this part in a new design.

**PREVIEW:** Device has been announced but is not in production. Samples may or may not be available.

**OBSOLETE:** TI has discontinued the production of the device.

<sup>(2)</sup> Eco Plan - The planned eco-friendly classification: Pb-Free (RoHS), Pb-Free (RoHS Exempt), or Green (RoHS & no Sb/Br) - please check <http://www.ti.com> for more information and additional product content details.

**TBD:** The Pb-Free/Green conversion plan has not been defined.

**Pb-Free (RoHS):** TI's terms "Lead-Free" or "Pb-Free" mean semiconductor products that are compatible with the current RoHS requirements for all RoHS materials, except lead, which may not exceed 0.1% by weight in homogeneous materials. Where designed to be soldered at high temperatures, TI Pb-Free products are suitable for use in high temperature applications.

**Pb-Free (RoHS Exempt):** This component has a RoHS exemption for either 1) lead-based flip-chip solder bumps used between the die and package, or 2) lead-based eutectic solder used between the leadframe and die. The component is otherwise considered Pb-Free (RoHS compatible) as defined above.

**Green (RoHS & no Sb/Br):** TI defines "Green" to mean Pb-Free (RoHS compatible), and free of Bromine (Br) and Antimony (Sb) based flame retardants (both of which are RoHS prohibited materials) in homogeneous material.

<sup>(3)</sup> MSL, Peak Temp. -- The Moisture Sensitivity Level rating according to the JEDEC industry standard classifications, and peak solder temperature.

**Important Information and Disclaimer:** The information provided on this page represents TI's knowledge and belief as of the date that it is provided. TI disclaims any warranty, express or implied, for the information provided by third parties, and makes no representation or warranty as to the accuracy of such information. Efforts are underway to better integrate information from third parties into TI's data sheets and Datasheets. TI continues to take reasonable steps to provide representative and accurate information but may not have conducted destructive testing or chemical analysis on all materials and is not responsible for any issues that arise from such testing or analysis. TI and TI suppliers consider certain information to be proprietary, and thus CAS numbers and other limited information may not be available for release. TI is not responsible for any errors or omissions in this information.

In no event shall TI's liability arising out of such information exceed the total purchase price of the TI part(s) at issue in this document sold by TI to Customer.



TAPE AND REEL INFORMATION



QUADRANT ASSIGNMENTS FOR PIN 1 ORIENTATION IN TAPE

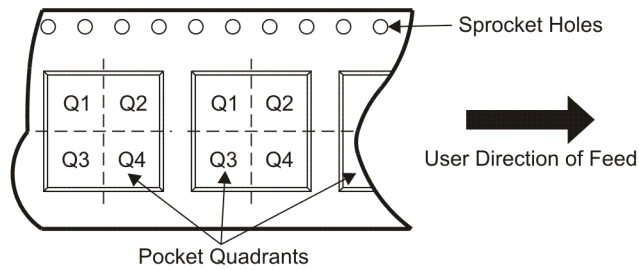

\*All dimensions are nominal

Device	Package Type	Package Drawing	Pins	SPQ	Reel Diameter (mm)	Reel Width W1 (mm)	A0 (mm)	B0 (mm)	K0 (mm)	P1 (mm)	W (mm)	Pin1 Quadrant
TPA2039D1YFFR	DSBGA	YFF	9	3000	180.0	8.4	1.34	1.34	0.81	4.0	8.0	Q1
TPA2039D1YFFT	DSBGA	YFF	9	250	180.0	8.4	1.34	1.34	0.81	4.0	8.0	Q1

**TAPE AND REEL BOX DIMENSIONS**



\*All dimensions are nominal

Device	Package Type	Package Drawing	Pins	SPQ	Length (mm)	Width (mm)	Height (mm)
TPA2039D1YFFR	DSBGA	YFF	9	3000	190.5	212.7	31.8
TPA2039D1YFFT	DSBGA	YFF	9	250	190.5	212.7	31.8

[查询"TPA2039D1"供应商](#)

YFF (S-XBGA-N9)

DIE-SIZE BALL GRID ARRAY

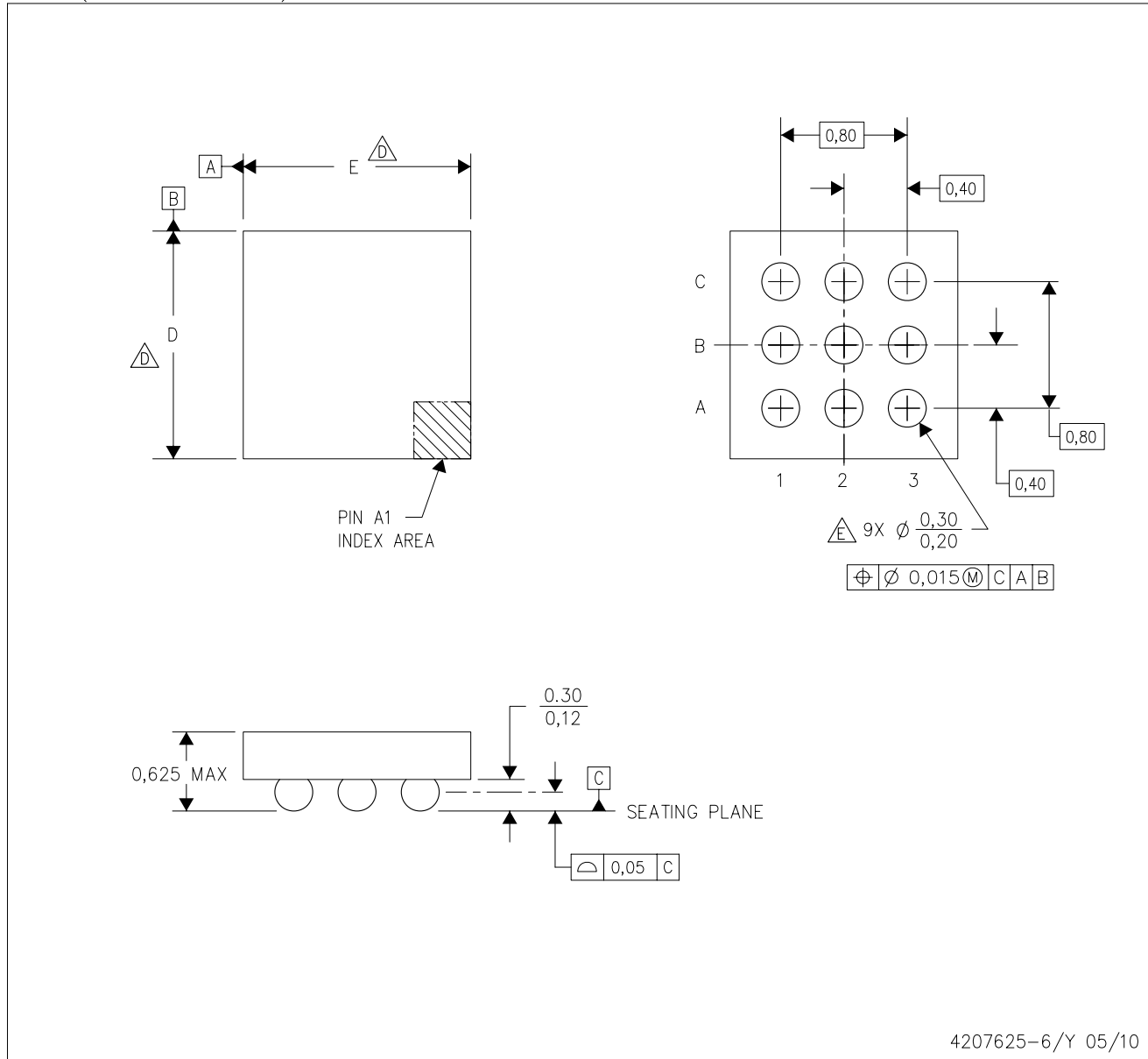

- NOTES:
- A. All linear dimensions are in millimeters. Dimensioning and tolerancing per ASME Y14.5M-1994.
  - B. This drawing is subject to change without notice.
  - C. NanoFree™ package configuration.
  - $\triangle$  Devices in YFF package can have dimensions D ranging from 1.16 to 1.85 mm and dimension E ranging from 1.16 to 1.85 mm. To determine the exact package size of a particular device, refer to the device datasheet or contact a local TI representative.
  - E. Reference Product Data Sheet for array population.  
3 x 3 matrix pattern is shown for illustration only.
  - F. This package contains Pb-free balls.

NanoFree is a trademark of Texas Instruments.

## IMPORTANT NOTICE

Texas Instruments Incorporated and its subsidiaries (TI) reserve the right to make corrections, modifications, enhancements, improvements, and other changes to its products and services at any time and to discontinue any product or service without notice. Customers should obtain the latest relevant information before placing orders and should verify that such information is current and complete. All products are sold subject to TI's terms and conditions of sale supplied at the time of order acknowledgment.

TI warrants performance of its hardware products to the specifications applicable at the time of sale in accordance with TI's standard warranty. Testing and other quality control techniques are used to the extent TI deems necessary to support this warranty. Except where mandated by government requirements, testing of all parameters of each product is not necessarily performed.

TI assumes no liability for applications assistance or customer product design. Customers are responsible for their products and applications using TI components. To minimize the risks associated with customer products and applications, customers should provide adequate design and operating safeguards.

TI does not warrant or represent that any license, either express or implied, is granted under any TI patent right, copyright, mask work right, or other TI intellectual property right relating to any combination, machine, or process in which TI products or services are used. Information published by TI regarding third-party products or services does not constitute a license from TI to use such products or services or a warranty or endorsement thereof. Use of such information may require a license from a third party under the patents or other intellectual property of the third party, or a license from TI under the patents or other intellectual property of TI.

Reproduction of TI information in TI data books or data sheets is permissible only if reproduction is without alteration and is accompanied by all associated warranties, conditions, limitations, and notices. Reproduction of this information with alteration is an unfair and deceptive business practice. TI is not responsible or liable for such altered documentation. Information of third parties may be subject to additional restrictions.

Resale of TI products or services with statements different from or beyond the parameters stated by TI for that product or service voids all express and any implied warranties for the associated TI product or service and is an unfair and deceptive business practice. TI is not responsible or liable for any such statements.

TI products are not authorized for use in safety-critical applications (such as life support) where a failure of the TI product would reasonably be expected to cause severe personal injury or death, unless officers of the parties have executed an agreement specifically governing such use. Buyers represent that they have all necessary expertise in the safety and regulatory ramifications of their applications, and acknowledge and agree that they are solely responsible for all legal, regulatory and safety-related requirements concerning their products and any use of TI products in such safety-critical applications, notwithstanding any applications-related information or support that may be provided by TI. Further, Buyers must fully indemnify TI and its representatives against any damages arising out of the use of TI products in such safety-critical applications.

TI products are neither designed nor intended for use in military/aerospace applications or environments unless the TI products are specifically designated by TI as military-grade or "enhanced plastic." Only products designated by TI as military-grade meet military specifications. Buyers acknowledge and agree that any such use of TI products which TI has not designated as military-grade is solely at the Buyer's risk, and that they are solely responsible for compliance with all legal and regulatory requirements in connection with such use.

TI products are neither designed nor intended for use in automotive applications or environments unless the specific TI products are designated by TI as compliant with ISO/TS 16949 requirements. Buyers acknowledge and agree that, if they use any non-designated products in automotive applications, TI will not be responsible for any failure to meet such requirements.

Following are URLs where you can obtain information on other Texas Instruments products and application solutions:

<b>Products</b>		<b>Applications</b>	
Amplifiers	<a href="http://amplifier.ti.com">amplifier.ti.com</a>	Audio	<a href="http://www.ti.com/audio">www.ti.com/audio</a>
Data Converters	<a href="http://dataconverter.ti.com">dataconverter.ti.com</a>	Automotive	<a href="http://www.ti.com/automotive">www.ti.com/automotive</a>
DLP® Products	<a href="http://www.dlp.com">www.dlp.com</a>	Communications and Telecom	<a href="http://www.ti.com/communications">www.ti.com/communications</a>
DSP	<a href="http://dsp.ti.com">dsp.ti.com</a>	Computers and Peripherals	<a href="http://www.ti.com/computers">www.ti.com/computers</a>
Clocks and Timers	<a href="http://www.ti.com/clocks">www.ti.com/clocks</a>	Consumer Electronics	<a href="http://www.ti.com/consumer-apps">www.ti.com/consumer-apps</a>
Interface	<a href="http://interface.ti.com">interface.ti.com</a>	Energy	<a href="http://www.ti.com/energy">www.ti.com/energy</a>
Logic	<a href="http://logic.ti.com">logic.ti.com</a>	Industrial	<a href="http://www.ti.com/industrial">www.ti.com/industrial</a>
Power Mgmt	<a href="http://power.ti.com">power.ti.com</a>	Medical	<a href="http://www.ti.com/medical">www.ti.com/medical</a>
Microcontrollers	<a href="http://microcontroller.ti.com">microcontroller.ti.com</a>	Security	<a href="http://www.ti.com/security">www.ti.com/security</a>
RFID	<a href="http://www.ti-rfid.com">www.ti-rfid.com</a>	Space, Avionics & Defense	<a href="http://www.ti.com/space-avionics-defense">www.ti.com/space-avionics-defense</a>
RF/IF and ZigBee® Solutions	<a href="http://www.ti.com/lprf">www.ti.com/lprf</a>	Video and Imaging	<a href="http://www.ti.com/video">www.ti.com/video</a>
		Wireless	<a href="http://www.ti.com/wireless-apps">www.ti.com/wireless-apps</a>