

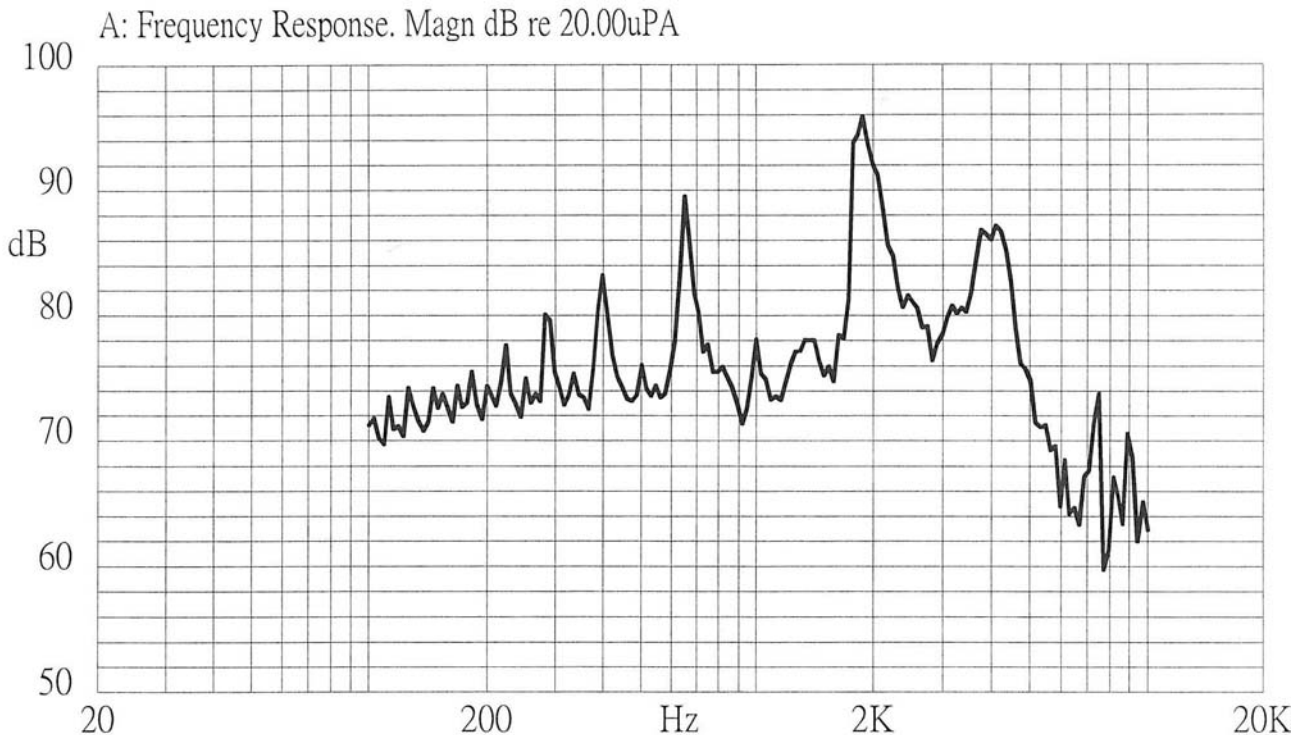

### Specifications

Rated voltage	6 Vo-p	
Operating voltage	3.0 - 12.0 Vo-p	
Mean current	50 mA max.	
Coil resistance	50 ±7.0 Ω	Applying rated voltage, 2048 Hz square wave, ½ duty
Sound output	Min. 85 (Typical 96) dBA	Distance at 10cm (A-weight free air). Applying rated voltage of 2048 Hz, square wave, ½ duty.
Rated frequency	2,048 Hz	
Operating temperature	-20 ~ +60° C	
Storage temperature	-30 ~ +70° C	
Dimensions	ø16.0 x H14.0 mm	See attached drawing
Weight	4.6 g	
Material	PPO (Black)	
Terminal	Pin type (Au Plating)	See attached drawing
RoHS	yes	

### Frequency Response Curve

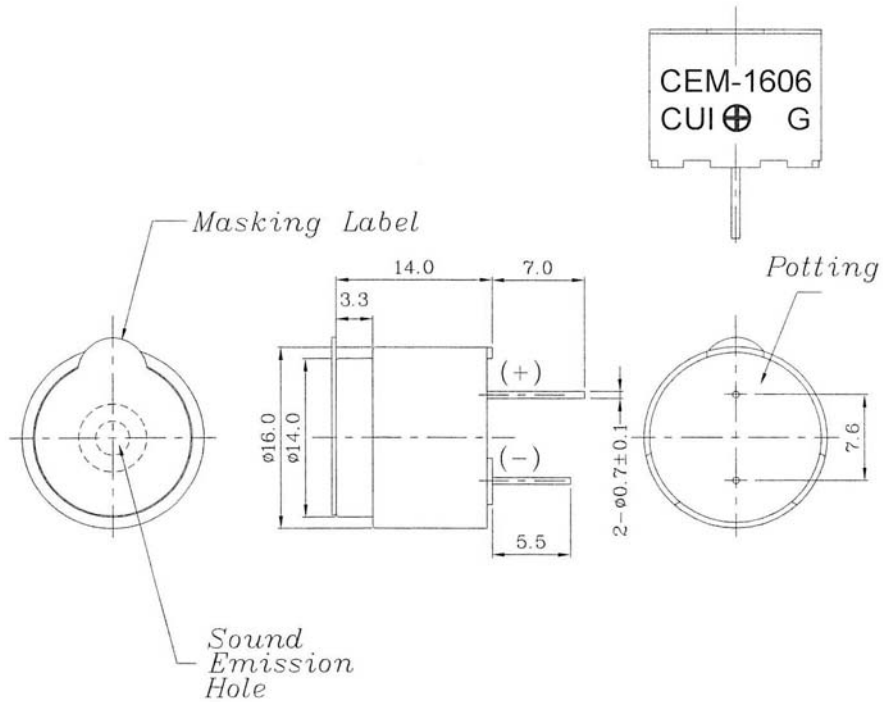
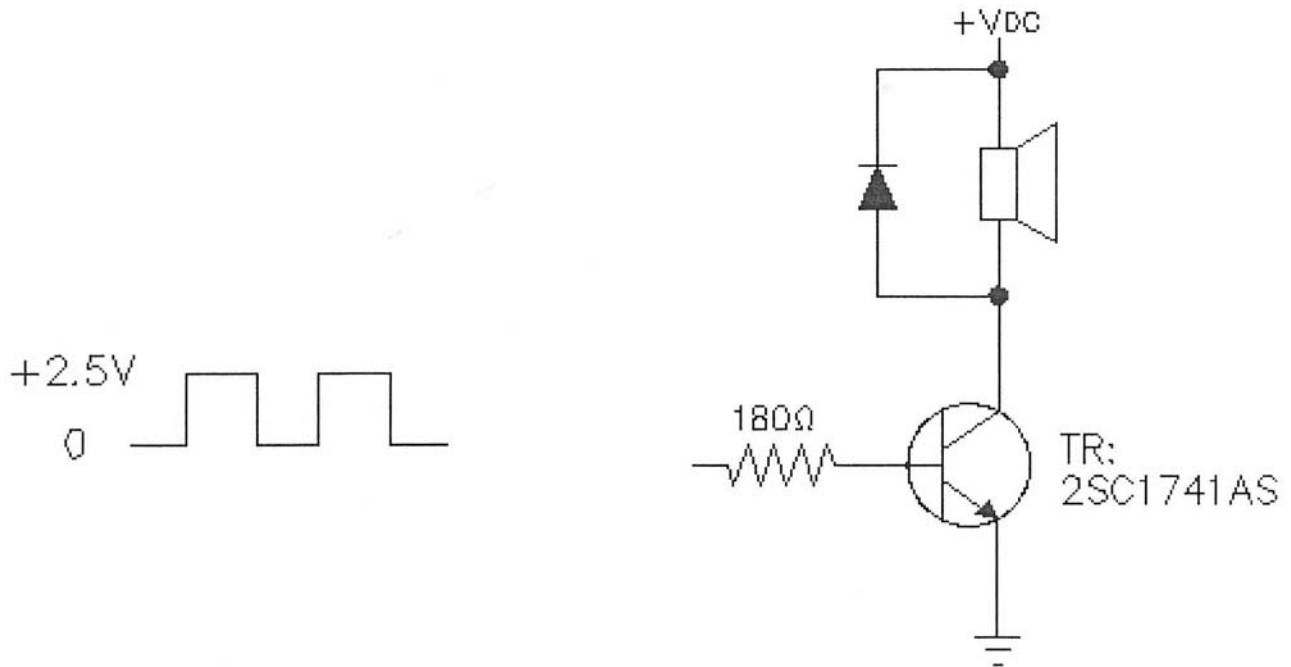

**Appearance Drawing**

 Tolerance:  $\pm 0.5$ 

**Measurement Method**

**Mechanical Characteristics**

Item	Test Condition	Evaluation Standard
Solderability	Lead terminals are immersed in rosin for 5 seconds and then immersed in solder bath of $270 \pm 5^\circ\text{C}$ for $3 \pm 1$ seconds.	90% min. lead terminals should be wet with solder. (Except the edge of the terminal.)
Soldering Heat Resistance	Lead terminals are immersed up to 1.5 mm from the buzzer's body in solder bath of $260 \pm 5^\circ\text{C}$ for $3 \pm 1$ seconds.	No in interference in operation.
Terminal Mechanical Strength	Apply a force of 9.8 N (1.0 kg) to each terminal in each axial direction.	No damage or cutting off.
Vibration	The buzzer will be measured after applying a vibration amplitude of 1.5mm with 10 to 55 Hz band of vibration frequency to each of the 3 perpendicular directions for 2 hours.	After the test, the part should meet specifications without any damage to the appearance and the SPL should be within $\pm 10$ dBA of the initial measurement.
Drop Test	The part is to be dropped from a height of 75 cm onto a 40 mm thick wooden board 3 times in 3 axis (X, Y, Z) for a total of 9 drops.	

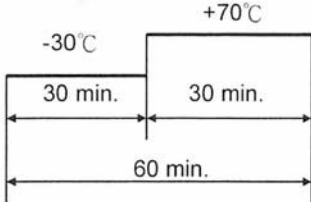
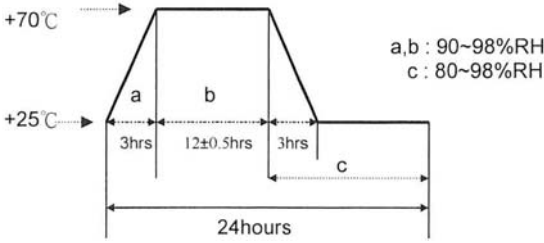
**Environment Test**

Item	Test Condition	Evaluation Standard
High temp. test	The part will be subjected to $+70^\circ\text{C}$ for 96 hours.	
Low temp. test	The part will be subjected to $-30^\circ\text{C}$ for 96 hours	
Thermal shock	The part will be subjected to 10 cycles. One cycle will consist of: <div style="text-align: center;">  </div>	
Temp./Humidity cycle	The part shall be subjected to 10 cycles. One cycle will be 24 hours and consist of: <div style="text-align: center;">  </div>	After the test, the part should meet specifications without any damage to the appearance or performance except SPL. After 4 hours at $25^\circ\text{C}$ , the SPL should be within $\pm 10$ dBA of the initial measurement.

## Reliability Tests

Item	Test Condition	Evaluation Standard
Operating (Life Test)	1. Continuous life test: The part will be subjected to 72 hours at 45°C with 6 V, 2048 Hz applied.  2. Intermittent life test: A duty cycle of 1 minute on, 1 minute off, a minimum of 10,000 times at room temp. (+25 ±10°C) with 6 V, 2048 Hz applied.	After the test, the part shall meet specifications without any damage to the appearance. After 4 hours at +25°C, the SPL should be within ±10 dBA of the initial SPL.

## Test Conditions

Standard Test Condition	a) Temperature: +5 ~ +35°C	b) Humidity: 45 - 85%	c) Pressure: 860 - 1060 mbar
Judgement Test Condition	a) Temperature: +25±2°C	b) Humidity: 60 - 70%	c) Pressure: 860 - 1060 mbar

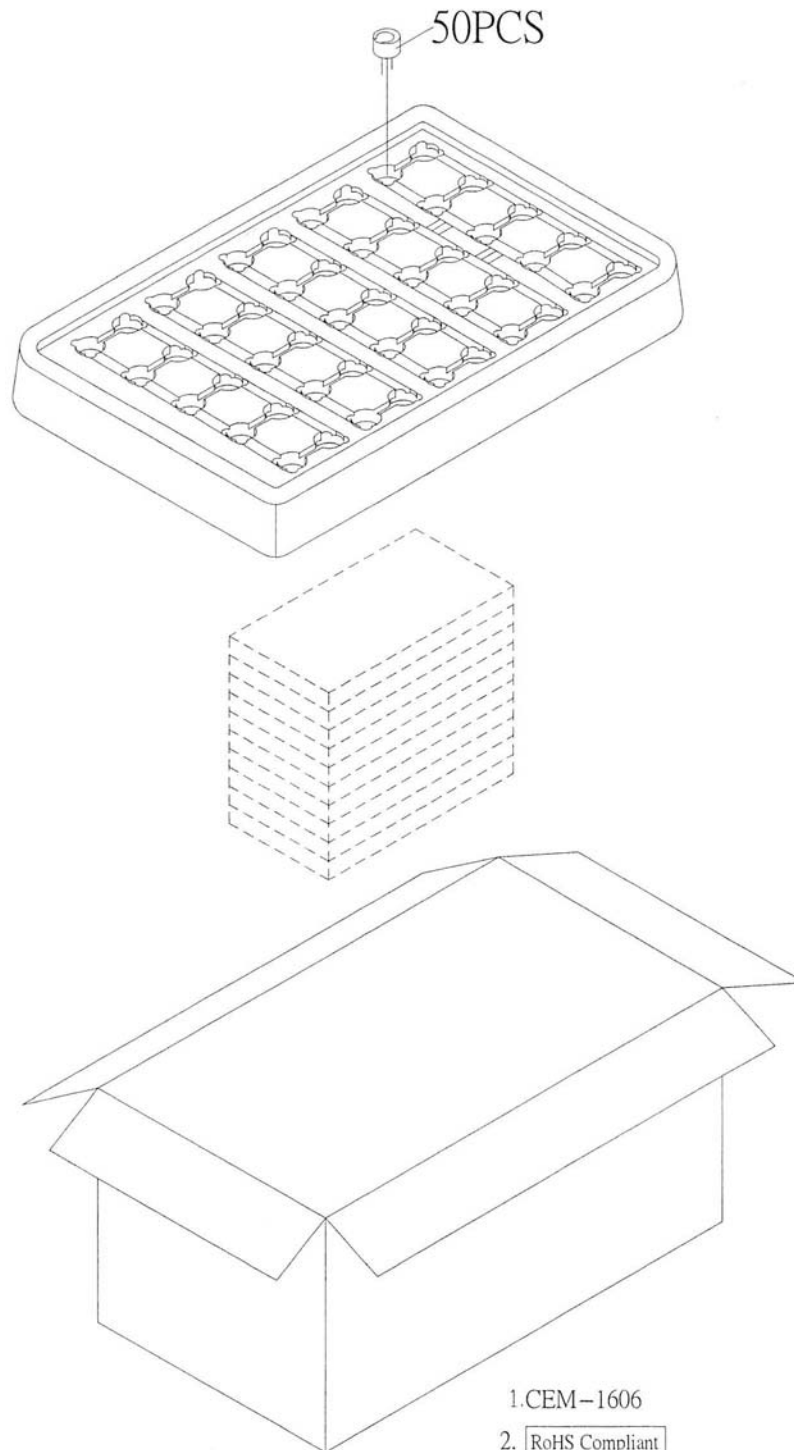
**Packaging**

	320mmx170mmx28mm	1x50PCS=50PCS
	340mmx190mmx310mm	10x50PCS=500PCS
	690mmx390mmx350mm	4x500PCS=2000PCS