

Rad-Tolerant Class-V, Precision Analog Controller

Check for Samples: [UC19432-SP](#)

FEATURES

- QML-V Qualified, SMD 5962-09233
- Rad Tolerant: 30 kRad(Si) TID ⁽¹⁾
 - TID Dose Rate = 10 mRad/sec
- Programmable Transconductance for Optimum Current Drive
- Accessible 1.3 V precision Reference
- Both Error Amplifier Inputs Available
- 0.7% Overall Reference Tolerance
- 0.4% Initial Accuracy
- 2.4-V to 24-V Operating Supply Voltage and User Programmable Reference
- Reference Accuracy Maintained for Entire Range of Supply Voltage

(1) Radiation tolerance is a typical value based upon initial device qualification. Radiation Lot Acceptance Testing is available - contact factory for details.

- Superior Accuracy and Easier Compensation for Optoisolator Application
- Low Quiescent Current (0.5 mA Typ)

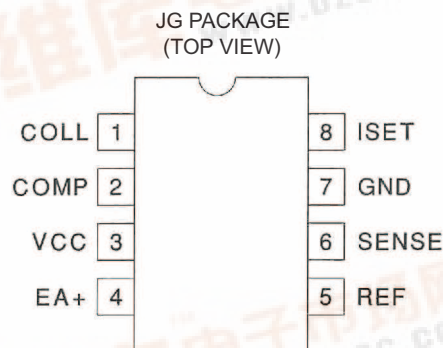

DESCRIPTION

The UC19432 is an adjustable precision analog controller with 100-mA sink capability if the ISET pin is grounded. A resistor between ISET and ground will modify the transconductance while decreasing the maximum current sink. This will add further control in the optocoupler configuration. The trimmed precision reference along with the non-inverting error amplifier inputs are accessible for custom configuration. A sister device, the UC19431 adjustable shunt regulator, has an on-board resistor network providing six preprogrammed voltage levels, as well as external programming capability.

ORDERING INFORMATION

T _A	PACKAGE	ORDERABLE PART NUMBER	TOP-SIDE MARKING
-55°C to 125°C	CDIP-8	5962-0923301VPA	UC19432-SP



Please be aware that an important notice concerning availability, standard warranty, and use in critical applications of Texas Instruments semiconductor products and disclaimers thereto appears at the end of this data sheet.

PRODUCTION DATA information is current as of publication date. Products conform to specifications per the terms of the Texas Instruments standard warranty. Production processing does not necessarily include testing of all parameters.

Copyright © 2009–2010, Texas Instruments Incorporated



FUNCTIONAL BLOCK DIAGRAM

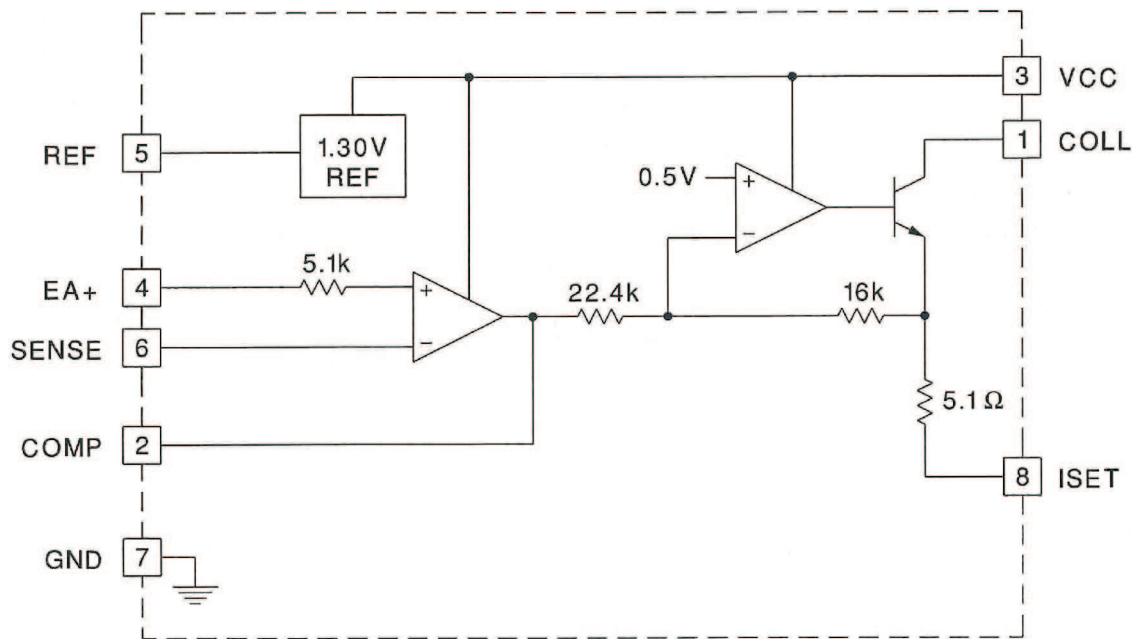

ABSOLUTE MAXIMUM RATINGS⁽¹⁾

over operating free-air temperature range (unless otherwise noted)

		VALUE	UNIT
VCC	Supply voltage	24	V
V _{COLL}	Regulated output	24	V
SENSE, EA+	EA input	6	V
COMP	EA compensation	6	V
REF	Reference output	6	V
I _{COLL}	Output sink current (continuous or time average)	125	mA
ISET	Output source current (continuous or time average)	-125	mA
	Power dissipation at T _A ≤ 25°C Derate 8 mW/°C for T _A > 25°C	1	W
	Storage temperature range	-65 to 150	°C
	Junction temperature	-55 to 150	°C
	Lead temperature (soldering, 10 seconds)	300	°C

(1) Stresses beyond those listed under "absolute maximum ratings" may cause permanent damage to the device. These are stress ratings only. Exposure to absolute-maximum-rated conditions for extended periods may affect device reliability.

ELECTRICAL CHARACTERISTICS

over operating free-air temperature range, COLL output = 2.4 V to 24 V, VCC = 15 V, I_{COLL} = 10 mA, T_A = T_J = –55°C to 125°C (unless otherwise noted).

PARAMETER	TEST CONDITIONS	MIN	TYP	MAX	UNIT
Reference voltage tolerance	T _A = 25°C, V _{COLL} = 5 V	1.295	1.3	1.305	V
Reference temperature tolerance	V _{COLL} = 5 V	1.291	1.3	1.309	V
Reference line regulation	VCC = 2.4 V to 24 V, V _{COLL} = 5 V		10	38	mV
Reference load regulation	I _{COLL} = 10 mA TO 50 mA, V _{COLL} = 5 V		10	38	mV
Reference sink current				10	μA
Reference source current		-10			μA
EA input bias current		-0.5	-0.2		μA
EA input offset voltage		-4		4	mV
EA+ Operational voltage limitations		0.9		1.6	V
EA output current sink (internally limited)		16			μA
EA output current source				-0.8	mA
Minimum operating current	VCC = 24 V, V _{COLL} = 5 V		0.5	0.8	mA
Collector current limit ⁽¹⁾	V _{COLL} = VCC = 24 V, Ref = 1.3 V, ISET = GND		130	155	mA
Collector saturation	I _{COLL} = 20 mA	0.7	1.1	1.5	V
Transconductance (gm) ^{(1) (2)}	VCC = 2.4 V to 24 V, V _{COLL} = 3 V, ISET = GND	-170	-140	-110	mS
Error amplifier AVOL		60	90		dB
Error amplifier GBW		1.5	3		MHz
Transconductance amplifier GBW			3		MHz

(1) Programmed transconductance and collector current limit equations are specified in the ISET pin description.

(2) Measured as ΔI_{COLL}/ΔV_{COMP} for I_{COLL} = 5 mA to 20 mA.

PIN DESCRIPTIONS

COLL The collector of the output transistor with a maximum voltage of 24 V. This pin is the output of the transconductance amplifier. The overall open loop voltage gain of the transconductance amplifier is gm x R_L, where gm is designed to be –140 mS ±30 mS and R_L represents the output load.

COMP The output of the error amplifier and the input to the transconductance amplifier. This pin is available to compensate the high frequency gain of the error amplifier. It is internally voltage limited to approximately 2 V.

EA+ The non-inverting input to the error amplifier.

GND The reference and power ground for the device. The power ground of the output transistor is isolated on the chip from the substrate ground used to bias the remainder of the device.

ISET The current set pin for the transconductance amplifier. The transconductance will be –140 mS as specified in the electrical table if this pin is grounded. If a resistance, R_L, is added to the ISET pin, the resulting new transconductance is calculated using Equation 1. The maximum current will be approximated by Equation 2.

$$gm = \frac{-0.714}{(5.1 \Omega + R_L)} \quad (1)$$

$$I_{MAX} = \frac{0.65 V}{5.1 \Omega + R_L} \quad (2)$$

REF The output of the trimmed precision reference. It can source or sink 10 μA and still maintain less than ±1% output variation.

SENSE The inverting terminal of the error amplifier used as both the voltage sense input to the error amplifier and its other compensation point. The error amplifier uses the SENSE input to compare against the 1.3-V on-chip reference.

The SENSE pin is also used as the under-voltage lockout (UVLO). It is intended to keep the chip from operating until the internal reference is properly biased. The threshold is approximately 1 V. It is important that once the UVLO is released, the error amplifier can drive the transconductance amplifier to stabilize the loop. If a capacitor is connected between the SENSE and COMP pins to create a pole, it will limit the slew rate of the error amplifier. To increase the bandwidth and ensure startup a low load current, it is recommended to create a zero along with the pole as shown in the UC19431 shunt regulator application. The error amplifier must slew 2 V to drive the transconductance amplifier initially on.

VCC The power connection for the device. The minimum to maximum operating voltage is 2.4 V to 24 V. The quiescent current is typically 0.5 mA.

OVER-VOLTAGE COMPARATOR APPLICATION

The signal V_{IN} senses the input voltage. As long as the input voltage is less than 5.5 V, the output is equal to the voltage on V_{IN} . During this region of operation, the diode is reversed biased which keeps the EA+ pin at 1.3 V. When V_{IN} exceeds the over-voltage threshold of 5.5 V, the output is driven low. This forward biases the diode and creates hysteresis by changing the threshold to 4.5 V.

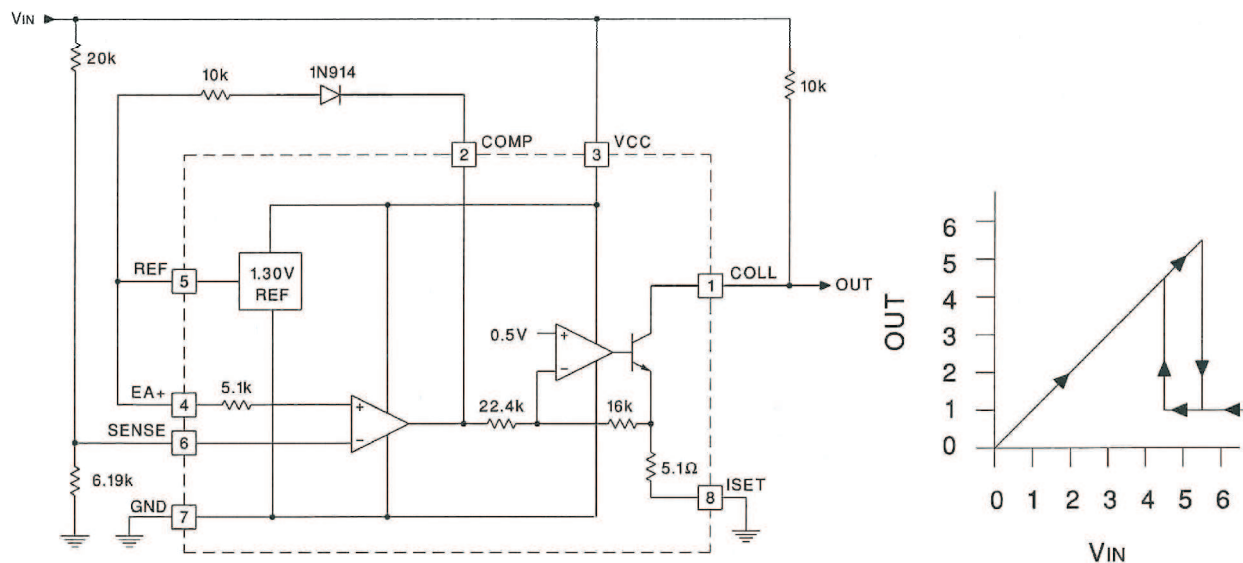

Figure 1. 5.5-V Over-Voltage Comparator With Hysteresis

OPTOCOUPLER APPLICATION

The optocoupler application shown in Figure 2 takes advantage of the accessible pins REF and ISET. The ISET pin has a 33-Ω resistor to ground that protects the optocoupler by limiting the current to about 16 mA. This also lowers the transconductance to approximately 19 mS. The ability to adjust the transconductance gives the designer further control of the loop gain. The REF pin is available to satisfy any high precision voltage requirements.

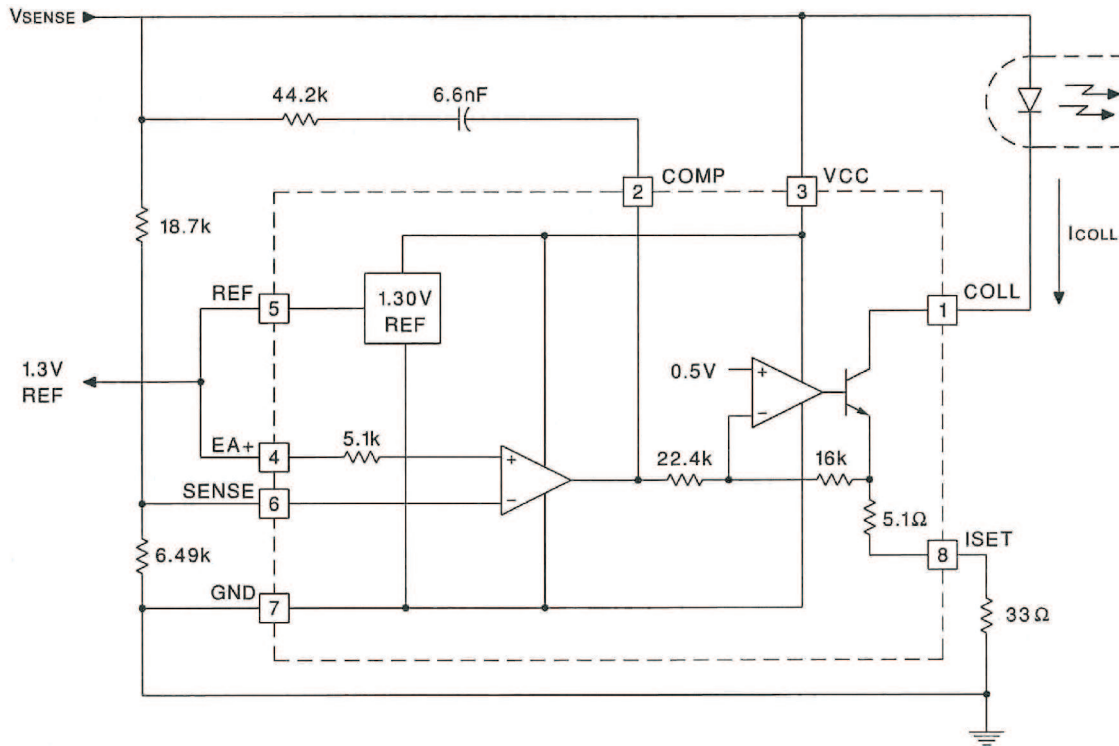

Figure 2. 5-V Optocoupler Application



www.ti.com

PACKAG

PACKAGING INFORMATION

Orderable Device	Status ⁽¹⁾	Package Type	Package Drawing	Pins	Package Qty	Eco Plan ⁽²⁾	Lead/Ball Finish	MSL Peak Temp
5962-0923301VPA	PREVIEW	CDIP	JG	8	50	TBD	Call TI	Call TI

⁽¹⁾ The marketing status values are defined as follows:

ACTIVE: Product device recommended for new designs.

LIFEBUY: TI has announced that the device will be discontinued, and a lifetime-buy period is in effect.

NRND: Not recommended for new designs. Device is in production to support existing customers, but TI does not recommend using this part in a new design.

PREVIEW: Device has been announced but is not in production. Samples may or may not be available.

OBSOLETE: TI has discontinued the production of the device.

⁽²⁾ Eco Plan - The planned eco-friendly classification: Pb-Free (RoHS), Pb-Free (RoHS Exempt), or Green (RoHS & no Sb/Br) - please check <http://www.ti.com> for more information and additional product content details.

TBD: The Pb-Free/Green conversion plan has not been defined.

Pb-Free (RoHS): TI's terms "Lead-Free" or "Pb-Free" mean semiconductor products that are compatible with the current RoHS requirements for all RoHS materials, with the exception of lead not exceed 0.1% by weight in homogeneous materials. Where designed to be soldered at high temperatures, TI Pb-Free products are suitable for use in applications that require high temperature soldering processes.

Pb-Free (RoHS Exempt): This component has a RoHS exemption for either 1) lead-based flip-chip solder bumps used between the die and package, or 2) lead-based eutectic solder used between the leadframe and die. The component is otherwise considered Pb-Free (RoHS compatible) as defined above.

Green (RoHS & no Sb/Br): TI defines "Green" to mean Pb-Free (RoHS compatible), and free of Bromine (Br) and Antimony (Sb) based flame retardants (excluding those materials permitted in homogeneous material).

⁽³⁾ MSL, Peak Temp. -- The Moisture Sensitivity Level rating according to the JEDEC industry standard classifications, and peak solder temperature.

Important Information and Disclaimer: The information provided on this page represents TI's knowledge and belief as of the date that it is provided. TI disclaims any warranty, expressed or implied, for the information provided by third parties, and makes no representation or warranty as to the accuracy of such information. Efforts are underway to better integrate information from third parties into TI's data sheets and Datasheets. TI continues to take reasonable steps to provide representative and accurate information but may not have conducted destructive testing or chemical analysis on all materials included in its products. TI and TI suppliers consider certain information to be proprietary, and thus CAS numbers and other limited information may not be available for release.

In no event shall TI's liability arising out of such information exceed the total purchase price of the TI part(s) at issue in this document sold by TI to Customer.

OTHER QUALIFIED VERSIONS OF UC19432-SP :

- Catalog: [UC19432](#)

NOTE: Qualified Version Definitions:

- Catalog - TI's standard catalog product

JG (R-GDIP-T8)

CERAMIC DUAL-IN-LINE

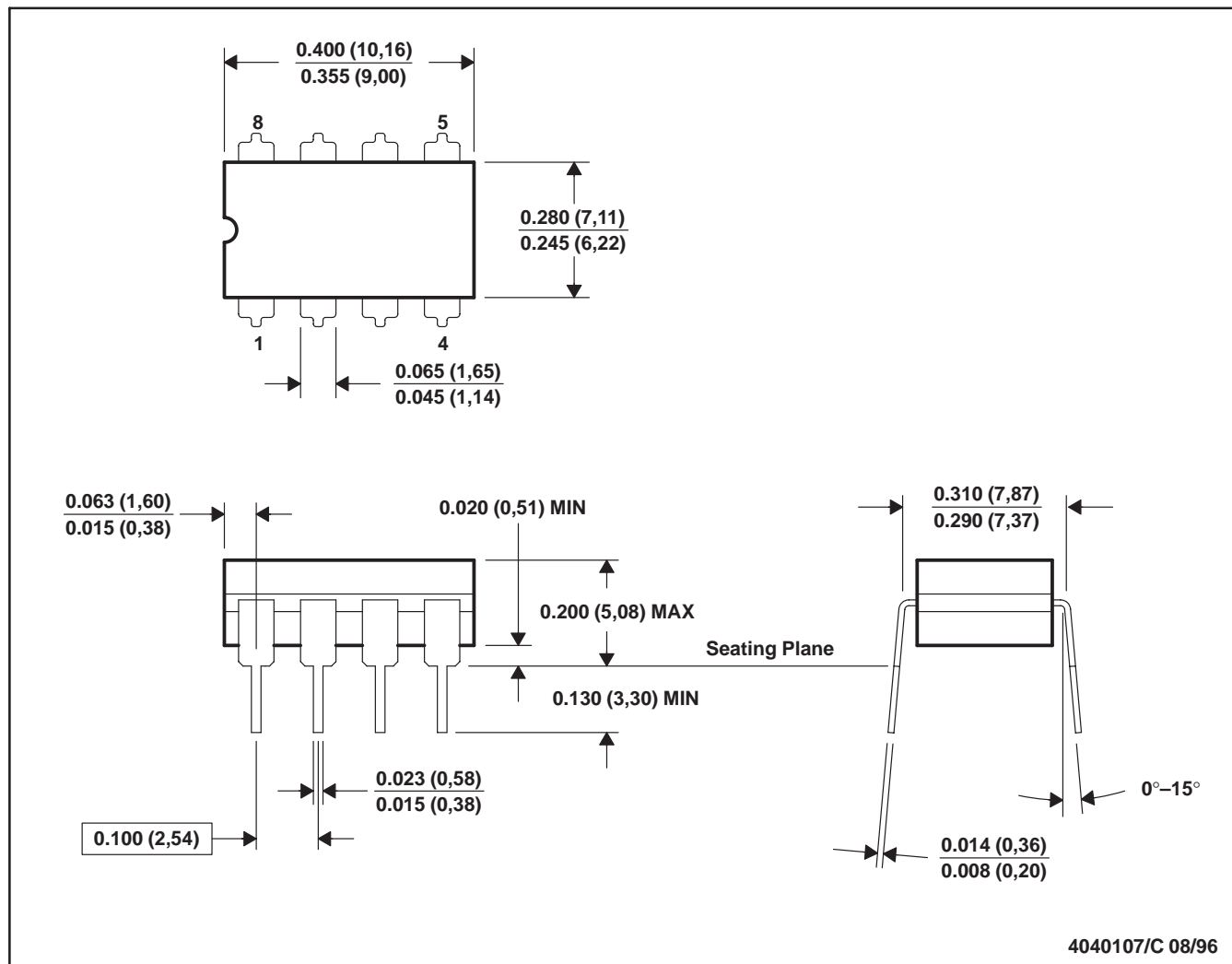

- NOTES: A. All linear dimensions are in inches (millimeters).
 B. This drawing is subject to change without notice.
 C. This package can be hermetically sealed with a ceramic lid using glass frit.
 D. Index point is provided on cap for terminal identification.
 E. Falls within MIL STD 1835 GDIP1-T8

IMPORTANT NOTICE

Texas Instruments Incorporated and its subsidiaries (TI) reserve the right to make corrections, modifications, enhancements, improvements, and other changes to its products and services at any time and to discontinue any product or service without notice. Customers should obtain the latest relevant information before placing orders and should verify that such information is current and complete. All products are sold subject to TI's terms and conditions of sale supplied at the time of order acknowledgment.

TI warrants performance of its hardware products to the specifications applicable at the time of sale in accordance with TI's standard warranty. Testing and other quality control techniques are used to the extent TI deems necessary to support this warranty. Except where mandated by government requirements, testing of all parameters of each product is not necessarily performed.

TI assumes no liability for applications assistance or customer product design. Customers are responsible for their products and applications using TI components. To minimize the risks associated with customer products and applications, customers should provide adequate design and operating safeguards.

TI does not warrant or represent that any license, either express or implied, is granted under any TI patent right, copyright, mask work right, or other TI intellectual property right relating to any combination, machine, or process in which TI products or services are used. Information published by TI regarding third-party products or services does not constitute a license from TI to use such products or services or a warranty or endorsement thereof. Use of such information may require a license from a third party under the patents or other intellectual property of the third party, or a license from TI under the patents or other intellectual property of TI.

Reproduction of TI information in TI data books or data sheets is permissible only if reproduction is without alteration and is accompanied by all associated warranties, conditions, limitations, and notices. Reproduction of this information with alteration is an unfair and deceptive business practice. TI is not responsible or liable for such altered documentation. Information of third parties may be subject to additional restrictions.

Resale of TI products or services with statements different from or beyond the parameters stated by TI for that product or service voids all express and any implied warranties for the associated TI product or service and is an unfair and deceptive business practice. TI is not responsible or liable for any such statements.

TI products are not authorized for use in safety-critical applications (such as life support) where a failure of the TI product would reasonably be expected to cause severe personal injury or death, unless officers of the parties have executed an agreement specifically governing such use. Buyers represent that they have all necessary expertise in the safety and regulatory ramifications of their applications, and acknowledge and agree that they are solely responsible for all legal, regulatory and safety-related requirements concerning their products and any use of TI products in such safety-critical applications, notwithstanding any applications-related information or support that may be provided by TI. Further, Buyers must fully indemnify TI and its representatives against any damages arising out of the use of TI products in such safety-critical applications.

TI products are neither designed nor intended for use in military/aerospace applications or environments unless the TI products are specifically designated by TI as military-grade or "enhanced plastic." Only products designated by TI as military-grade meet military specifications. Buyers acknowledge and agree that any such use of TI products which TI has not designated as military-grade is solely at the Buyer's risk, and that they are solely responsible for compliance with all legal and regulatory requirements in connection with such use.

TI products are neither designed nor intended for use in automotive applications or environments unless the specific TI products are designated by TI as compliant with ISO/TS 16949 requirements. Buyers acknowledge and agree that, if they use any non-designated products in automotive applications, TI will not be responsible for any failure to meet such requirements.

Following are URLs where you can obtain information on other Texas Instruments products and application solutions:

Products		Applications	
Amplifiers	amplifier.ti.com	Audio	www.ti.com/audio
Data Converters	dataconverter.ti.com	Automotive	www.ti.com/automotive
DLP® Products	www.dlp.com	Communications and Telecom	www.ti.com/communications
DSP	dsp.ti.com	Computers and Peripherals	www.ti.com/computers
Clocks and Timers	www.ti.com/clocks	Consumer Electronics	www.ti.com/consumer-apps
Interface	interface.ti.com	Energy	www.ti.com/energy
Logic	logic.ti.com	Industrial	www.ti.com/industrial
Power Mgmt	power.ti.com	Medical	www.ti.com/medical
Microcontrollers	microcontroller.ti.com	Security	www.ti.com/security
RFID	www.ti-rfid.com	Space, Avionics & Defense	www.ti.com/space-avionics-defense
RF/IF and ZigBee® Solutions	www.ti.com/lprf	Video and Imaging	www.ti.com/video
		Wireless	www.ti.com/wireless-apps