

REVISIONS													
LTR	DESCRIPTION	DATE (YR-MO-DA)	APPROVED										
A	Changed parameter (A_{OL}) in table I from 92 dB to 89 dB.	91-09-30	<i>DMP</i>										

REV													
SHEET													
REV													
SHEET													
REV STATUS OF SHEETS	REV	A					A						
	SHEET	1	2	3	4	5	6	7	8	9	10	11	

PMIC N/A	PREPARED BY <i>Steve Dunbar</i>	DEFENSE ELECTRONICS SUPPLY CENTER DAYTON, OHIO 45444	
STANDARDIZED MILITARY DRAWING THIS DRAWING IS AVAILABLE FOR USE BY ALL DEPARTMENTS AND AGENCIES OF THE DEPARTMENT OF DEFENSE	CHECKED BY <i>Steve Zuber</i>	MICROCIRCUIT, LINEAR, HIGH POWER, OPERATIONAL AMPLIFIER, HYBRID	
	APPROVED BY <i>McCord</i>		
	DRAWING APPROVAL DATE 91-03-27	SIZE A	CAGE CODE 67268
AMSC N/A	REVISION LEVEL A	SHEET 1 OF 11	

查询"5962-9063801HXA"供应商

1. SCOPE

1.1 Scope. This drawing forms a part of a one part - one part number documentation system (see 6.6). This drawing describes device requirements for hybrid microcircuits to be processed in accordance with MIL-H-38534. Two product assurance classes, military high reliability (device class H) and space application (device class K) and a choice of case outlines and lead finishes are available and are reflected in the Part or Identifying Number (PIN). When available, a choice of radiation hardness assurance levels are reflected in the PIN.

1.2 PIN. The PIN shall be as shown in the following example:

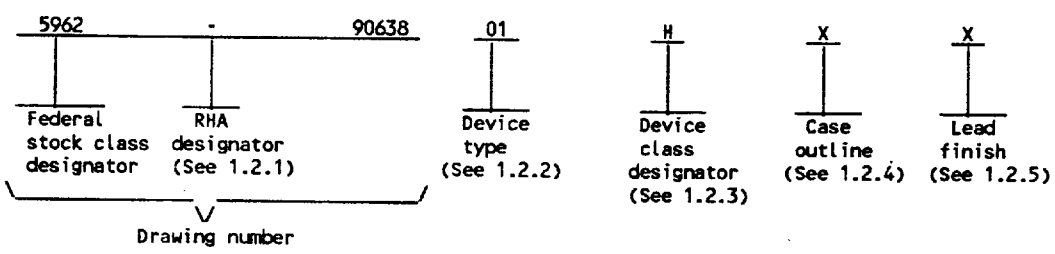

1.2.1 Radiation hardness assurance (RHA) designator. Device classes H and K RHA marked devices shall meet the MIL-H-38534 specified RHA levels and shall be marked with the appropriate RHA designator. A dash (-) indicates a non-RHA device.

1.2.2 Device type(s). The device type(s) shall identify the circuit function as follows:

Device type	Generic number	Circuit function
01	PA07M, MIOP42114	Power operational amplifier

1.2.3 Device class designator. This device class designator shall be a single letter identifying the product assurance level as follows:

Device class	Device requirements documentation
H or K	Certification and qualification to MIL-H-38534

1.2.4 Case outline(s). The case outline(s) shall be as designated in appendix C of MIL-M-38510, and as follows:

Outline letter	Case outline
X	See figure 1, T0-3 (8-lead) can package

1.2.5 Lead finish. The lead finish shall be as specified in MIL-H-38534 for classes H and K. Finish letter "X" shall not be marked on the microcircuit or its packaging. The "X" designation is for use in specifications when lead finishes A, B, and C are considered acceptable and interchangeable without preference.

1.3 Absolute maximum ratings.

Supply voltage (V_S)	±50 V dc
Output current (I_O)	5.0 A
Power dissipation (P_D) 1/-	67 W
Input voltage (differential)	±50 V dc
Input voltage (common-mode)	±50 V dc
Lead temperature (soldering, 10 seconds)	+300°C
Junction temperature (T_J)	+200°C
Storage temperature range	-65°C to +150°C
Case operating temperature range (T_C)	-55°C to +125°C

1/ Derate at 2.6°C/W above $T_C = +25°C$.

STANDARDIZED MILITARY DRAWING DEFENSE ELECTRONICS SUPPLY CENTER DAYTON, OHIO 45444	SIZE A		5962-90638
		REVISION LEVEL	SHEET 2

DESC FORM 193A
SEP 87

U S GOVERNMENT PRINTING OFFICE 1986-860-547

9004708 0026255 720

1.4 Recommended operating conditions.

Supply voltage (V_s) - - - - - ± 35 V dc
 Case operating temperature range (T_c) - - - - - -55°C to $+125^\circ\text{C}$

2. APPLICABLE DOCUMENTS

2.1 Government specifications, standards, and handbook. Unless otherwise specified, the following specifications, standards, and handbook of the issue listed in that issue of the Department of Defense Index of Specifications and Standards specified in the solicitation, form a part of this drawing to the extent specified herein.

SPECIFICATIONS

MILITARY

- MIL-M-38510 - Microcircuits, General Specification for.
- MIL-H-38534 - Hybrid Microcircuits, General Specification for.

STANDARDS

MILITARY

- MIL-STD-480 - Configuration Control-Engineering Changes, Deviations and Waivers.
- MIL-STD-883 - Test Methods and Procedures for Microelectronics.

HANDBOOK

MILITARY

- MIL-HDBK-780 - Standardized Military Drawings.

(Copies of the specifications, standards, and handbook required by manufacturers in connection with specific acquisition functions should be obtained from the contracting activity or as directed by the contracting activity.)

2.2 Order of precedence. In the event of a conflict between the text of this drawing and the references cited herein, the text of this drawing shall take precedence.

3. REQUIREMENTS

3.1 Item requirements. The individual item requirements shall be in accordance with MIL-H-38534 and as specified herein.

3.2 Design, construction, and physical dimensions. The design, construction, and physical dimensions shall be as specified in MIL-H-38534 and herein.

STANDARDIZED MILITARY DRAWING DEFENSE ELECTRONICS SUPPLY CENTER DAYTON, OHIO 45444	SIZE A	5962-90638
	REVISION LEVEL	SHEET 3

查询"5962-9063801HX" 供应商

3.2.1 Case outline(s). The case outline(s) shall be in accordance with 1.2.4 and figure 1 herein.

3.2.2 Terminal connections. The terminal connections shall be as specified on figure 2.

3.3 Electrical performance characteristics. Unless otherwise specified herein, the electrical performance characteristics are as specified in table I and shall apply over the full specified operating temperature range.

3.4 Electrical test requirements. The electrical test requirements shall be the subgroups specified in table II. The electrical tests for each subgroup are described in table I.

3.5 Marking. Marking shall be in accordance with MIL-H-38534. The part shall be marked with the PIN listed in 1.2 herein. In addition, the manufacturer's PIN may also be marked as listed in QML-38534.

3.6 Manufacturer eligibility. In addition to the general requirements of MIL-H-38534, the manufacturer of the part described herein shall submit for DESC-ECC review and approval electrical test data (variables format) on 22 devices from the initial quality conformance inspection group A lot sample, produced on the certified line, for each device type listed herein. The data should also include a summary of all parameters manually tested, and for those which, if any, are guaranteed.

3.7 Certificate of compliance. A certificate of compliance shall be required from a manufacturer in order to supply to this drawing. The certificate of compliance submitted to DESC-ECC shall affirm that the manufacturer's product meets the requirements of MIL-H-38534 and the requirements herein.

3.8 Certificate of conformance. A certificate of conformance as required in MIL-H-38534 shall be provided with each lot of microcircuits delivered to this drawing.

4. QUALITY ASSURANCE PROVISIONS

4.1 Sampling and inspection. Sampling and inspection procedures shall be in accordance with MIL-H-38534.

4.2 Screening. Screening shall be in accordance with MIL-H-38534. The following additional criteria shall apply:

- a. Burn-in test, method 1015 of MIL-STD-883.
 - (1) Test condition D using the circuit submitted with the certificate of compliance (see 3.7 herein).
 - (2) T_c as specified in accordance with table I of method 1015 of MIL-STD-883.
- b. Interim and final electrical test parameters shall be as specified in table II herein, except interim electrical parameter tests prior to burn-in are optional at the discretion of the manufacturer.
- c. Constant acceleration may be performed after burn-in upon approval by the qualifying activity.

4.3 Quality conformance inspection. Quality conformance inspection shall be in accordance with MIL-H-38534 and as specified herein.

STANDARDIZED MILITARY DRAWING DEFENSE ELECTRONICS SUPPLY CENTER DAYTON, OHIO 45444	SIZE A		5962-90638
		REVISION LEVEL	SHEET 4

DESC FORM 193A
SEP 87

U. S. GOVERNMENT PRINTING OFFICE: 1988-580-547

9004708 0026257 5T3

TABLE I. Electrical performance characteristics.

Test	Symbol	Conditions -55°C ≤ T _c ≤ +125°C V _S = ±35 V dc unless otherwise specified	Group A subgroups	Limits		Unit
				Min	Max	
Supply current	I _S	V _{IN} = 0 V dc, G = 100, ±R _{CL} = 0.2Ω, VCM = 0 V dc 2/	1,2 3		30 46	mA
Input offset voltage	V _{OS}	V _{IN} = 0 V dc, G = 100, V _S = ±12 V dc, ±R _{CL} = 0.2Ω 2/	1	-4.3	+4.3	mV
			2	-7.3	+7.3	
			3	-6.7	+6.7	
		V _{IN} = 0 V dc, G = 100, V _S = ±35 V dc, ±R _{CL} = 0.2Ω 2/	1	-2.0	+2.0	mV
			2	-5.0	+5.0	
			3	-4.4	+4.4	
		V _{IN} = 0 V dc, G = 100, V _S = ±50 V dc, ±R _{CL} = 0.2Ω 2/	1	-3.5	+3.5	mV
			2	-6.5	+6.5	
			3	-5.9	+5.9	
Input bias current, +IN	+I _B	V _{IN} = 0 V dc, R _{BIAS} ≤ 100 MΩ	2		10.0	nA
			1, 3		50.0	pA
Input bias current, -IN	-I _B	V _{IN} = 0 V dc, R _{BIAS} ≤ 100 MΩ	2		10.0	nA
			1, 3		50.0	pA
Input offset current	I _{OS}	V _{IN} = 0 V dc, R _{BIAS} ≤ 100 MΩ	2		10.0	nA
			1, 3		50.0	pA
Output voltage	V _O	V _S = ±50 V dc, I _O = 90 mA, R _L = 500Ω	4, 5, 6	45		V
		V _S = ±15.3 V dc, I _O = 5 A, R _L = 2.07Ω	4, 6	10.3		V
		V _S = ±11.3 V dc, I _O = 3 A, R _L = 2.07Ω	5	6.3		V
		V _S = ±29 V dc, I _O = 2 A, R _L = 12Ω	4, 5, 6	24		V

See footnotes at end of table

STANDARDIZED MILITARY DRAWING DEFENSE ELECTRONICS SUPPLY CENTER DAYTON, OHIO 45444	SIZE A	5962-90638	
		REVISION LEVEL	SHEET 5

TABLE I. Electrical performance characteristics - Continued.

Test	Symbol	Conditions ^{1/} -55°C ≤ T _C ≤ +125°C V _S = ±35 V dc unless otherwise specified	Group A subgroups	Limits		Unit
				Min	Max	
Current limits	I _{CL}	R _L = 2.07Ω, ±R _{CL} = 0.2Ω, ^{2/} V _S = ±16 V dc	4	2.6	3.9	A
Stability/noise	E _N	G = 1, V _S = ±35 V dc C _L = 10 nF	4, 5, 6		1.0	mV
Slew rate	S _R	R _L = 500Ω, V _S = ±35 V dc, V _{IN} ≥ 4 V _{p-p}	4, 5 5	2.5 1.25	10 10	V/μs
Open loop gain	A _{OL}	R _L = 500Ω, V _S = ±35 V dc, f = 15 Hz, V _{IN} ≥ .4 V _{p-p}	4, 5, 6	39		dB
Common mode rejection	CMR	V _S = ±34.5 V dc, f = dc V _{CM} = ±24.5 V dc	4, 5, 6	30		dB

1/ During all group A testing, terminal connection DAL (pin 7) is left open.

2/ A current limiting resistor (R_{CL}) is connected between C_L to the output and C_L to the output during these tests.

4.3.1 Group A inspection. Group A inspection shall be in accordance with MIL-H-38534 and as follows:

- a. Tests shall be as specified in table II herein.
- b. Subgroups 7, 8, 9, 10 and 11 in table I, method 5008 of MIL-STD-883 shall be omitted.

4.3.2 Group B inspection. Group B inspection shall be in accordance with MIL-H-38534.

4.3.3 Group C inspection. Group C inspection shall be in accordance with MIL-H-38534 and as follows:

- a. End-point electrical parameters shall be as specified in table II herein.
- b. Steady-state life test conditions, method 1005 of MIL-STD-883.
 - (1) Test condition D using the circuit submitted with the certificate of compliance (see 3.7 herein).
 - (2) T_C as specified in accordance with table I of method 1005 of MIL-STD-883.
 - (3) Test duration: 1,000 hours, except as permitted by method 1005 of MIL-STD-883.

STANDARDIZED MILITARY DRAWING DEFENSE ELECTRONICS SUPPLY CENTER DAYTON, OHIO 45444	SIZE A	5962-90638
	REVISION LEVEL A	SHEET 6

DESC FORM 193A
SEP 87

9004708 0026259 376

U S GOVERNMENT PRINTING OFFICE 1986-850-547

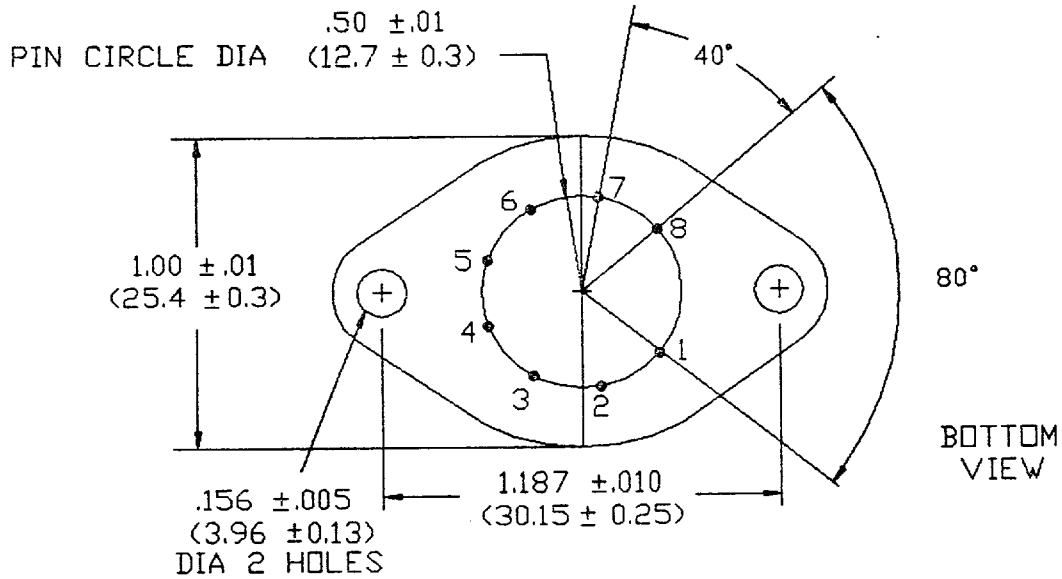
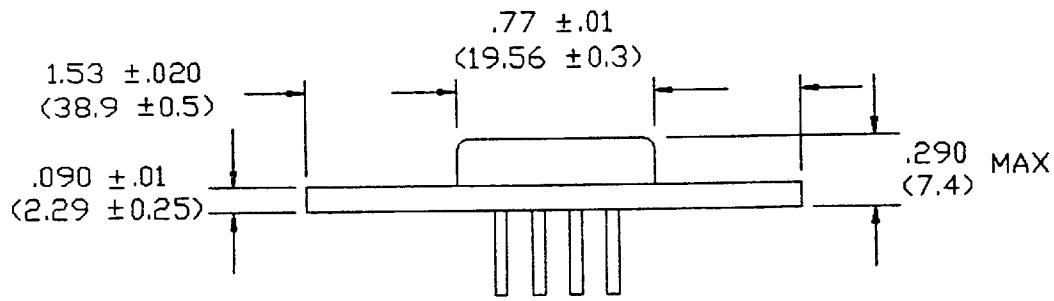

NOTES:

1. Dimensions are in inches.
2. Metric equivalents are given for general information only.
3. Metric equivalents are in parentheses.
4. Pin diameters shall be $.040 \pm .002$ (1.02 ± 0.05).
5. Pin lengths shall be $.48 \pm .02$ (12.2 ± 0.5).

FIGURE 1. Case outline X.

STANDARDIZED MILITARY DRAWING DEFENSE ELECTRONICS SUPPLY CENTER DAYTON, OHIO 45444	SIZE A	5962-90638
	REVISION LEVEL	SHEET 7

Device type	01
Case outline	X
Terminal number	Terminal symbol
1	OUT
2	C _L ⁺
3	+V _S
4	+IN
5	-IN
6	-V _S
7	BAL
8	C _L ⁻

FIGURE 2. Terminal connections.

STANDARDIZED MILITARY DRAWING DEFENSE ELECTRONICS SUPPLY CENTER DAYTON, OHIO 45444	SIZE A	5962-90638
	REVISION LEVEL	SHEET 8

TABLE II. Electrical test requirements.

MIL-STD-883 test requirements	Subgroups (per method 5008, group A test table)
Interim electrical parameters	
Final electrical test parameters	1*,2,3,4,5,6
Group A test requirements	1,2,3,4,5,6
Group C end-point electrical parameters	1,4
Group E end-point electrical parameters for RHA devices	Subgroups ** (per method 5005, group A test table)

*PDA applies to subgroup 1.

**When applicable to this standardized military drawing, the subgroups shall be defined.

4.3.4 Group D inspection. Group D inspection shall be in accordance with MIL-H-38534.

4.3.5 Group E inspection. Group E inspection is required only for parts intended to be marked as radiation hardness assured (see 3.5 herein). RHA levels for device classes H and K shall be M, D, R, and H. RHA quality conformance inspection sample tests shall be performed at the RHA level specified in the acquisition document.

- a. RHA tests for device classes H and K for levels M, D, R, and H shall be performed through each level to determine at what levels the devices meet the RHA requirements. These RHA tests shall be performed for initial qualification and after design or process changes which may affect the RHA performance of the device.
- b. End-point electrical parameters shall be as specified in table II herein.
- c. Prior to total dose irradiation, each selected sample shall be assembled in its qualified package. It shall pass the specified group A electrical parameters in table I for subgroups specified in table II herein.
- d. For device classes H and K, the devices shall be subjected to radiation hardness assured tests as specified in MIL-H-38534 for RHA level being tested, and meet the postirradiation end-point electrical parameter limits as defined in table I at $T_C = +25^\circ\text{C} \pm 5$ percent, after exposure.

STANDARDIZED MILITARY DRAWING DEFENSE ELECTRONICS SUPPLY CENTER DAYTON, OHIO 45444	SIZE A	5962-90638
	REVISION LEVEL	SHEET 9

- e. Prior to and during total dose irradiation testing, the devices shall be biased to establish a worst case condition as specified in the radiation exposure circuit.
- f. For device classes H and K, subgroups 1 and 2 in table V, method 5005 of MIL-STD-883 shall be tested as appropriate for device construction.
- g. When specified in the purchase order or contract, a copy of the RHA delta limits shall be supplied

5. PACKAGING

5.1 Packaging requirements. The requirements for packaging shall be in accordance with MIL-H-38534.

6. NOTES

6.1 Intended use. Microcircuits conforming to this drawing are intended for use for Government microcircuit applications (original equipment), design applications, and logistics purposes.

6.2 Replaceability. Microcircuits covered by this drawing will replace the same generic device covered by a contractor-prepared specification or drawing.

6.3 Configuration control of SMD's. All proposed changes to existing SMD's will be coordinated with the users of record for the individual documents. This coordination will be accomplished in accordance with MIL-STD-481 using DD Form 1693, Engineering Change Proposal (Short Form).

6.4 Record of users. Military and industrial users shall inform Defense Electronics Supply Center when a system application requires configuration control and the applicable SMD. DESC will maintain a record of users and this list will be used for coordination and distribution of changes to the drawings. Users of drawings covering microelectronic devices (FSC 5962) should contact DESC-ECC, telephone (513) 296-8527.

6.5 Comments. Comments on this drawing should be directed to DESC-ECC, Dayton, Ohio 45444, or telephone (513) 296-8525.

STANDARDIZED MILITARY DRAWING DEFENSE ELECTRONICS SUPPLY CENTER DAYTON, OHIO 45444	SIZE A	5962-90638
	REVISION LEVEL	SHEET 10

DESC FORM 193A
SEP 87

U.S. GOVERNMENT PRINTING OFFICE: 1988-350-547

9004708 0026263 8T7

[查询"5962-9063801HXA"供应商](#)

6.6 One part - one part number system. The one part - one part number system described below has been developed to allow for transitions between identical generic devices covered by the four major microcircuit requirements documents (MIL-M-38510, MIL-H-38534, MIL-I-38535, and 1.2.1 of MIL-STD-883) without the necessity for the generation of unique PIN's. The four military requirements documents represent different class levels, and previously when a device manufacturer upgraded military product from one class level to another, the benefits of the upgraded product were unavailable to the Original Equipment Manufacturer (OEM), that was contractually locked into the original unique PIN. By establishing a one part number system covering all four documents, the OEM can acquire to the highest class level available for a given generic device to meet system needs without modifying the original contract parts selection criteria.

<u>Military documentation format</u>	<u>Example PIN under new system</u>	<u>Manufacturing source listing</u>	<u>Document listing</u>
New MIL-M-38510 Military Detail Specifications (in the SMD format)	5962-XXXXXZZ(B or S)YY	QPL-38510 (Part 1 or 2)	MIL-BUL-103
New MIL-H-38534 Standardized Military Drawings	5962-XXXXXZZ(H or K)YY	QML-38534	MIL-BUL-103
New MIL-I-38535 Standardized Military Drawings	5962-XXXXXZZ(Q or V)YY	QML-38535	MIL-BUL-103
New 1.2.1 of MIL-STD-883 Standardized Military Drawings	5962-XXXXXZZ(M)YY	MIL-BUL-103	MIL-BUL-103

6.7 Sources of supply for device classes H and K. Sources of supply for device classes H and K are listed in QML-38534. The vendors listed in QML-38534 have submitted a certificate of compliance (see 3.7 herein) to DESC-ECC and have agreed to this drawing.

STANDARDIZED MILITARY DRAWING DEFENSE ELECTRONICS SUPPLY CENTER DAYTON, OHIO 45444	SIZE A	5962-90638
	REVISION LEVEL	SHEET 11