

REVISIONS												
LTR	DESCRIPTION	DATE (YR-MO-DA)	APPROVED									
REV												
SHEET												
REV												
SHEET												
REV STATUS OF SHEETS	REV SHEET											
PMIC N/A	STANDARDIZED MILITARY DRAWING	PREPARED BY <i>Larry T. Gauder</i>	DEFENSE ELECTRONICS SUPPLY CENTER DAYTON, OHIO 45444									
THIS DRAWING IS AVAILABLE FOR USE BY ALL DEPARTMENTS AND AGENCIES OF THE DEPARTMENT OF DEFENSE  AMSC N/A		CHECKED BY <i>Ray Monnin</i>	MICROCIRCUIT, DIGITAL, BIPOLAR ADVANCED LOW POWER SCHOTTKY, TTL, HEX NONINVERTING BUFFERS, MONOLITHIC SILICON									
		APPROVED BY <i>[Signature]</i>										
		DRAWING APPROVAL DATE 12 OCTOBER 1988	SIZE <b>A</b>	CAGE CODE <b>67268</b>	<b>5962-88742</b>							
REVISION LEVEL	SHEET 1 OF 9											

DESC FORM 193  
SEP 87

• U.S. GOVERNMENT PRINTING OFFICE: 1987 — 748-129/60911  
5962-E1082-2

DISTRIBUTION STATEMENT A. Approved for public release; distribution is unlimited.

1. SCOPE

1.1 Scope. This drawing describes device requirements for class B microcircuits in accordance with 1.2.1 of MIL-STD-883, "Provisions for the use of MIL-STD-883 in conjunction with compliant non-JAN devices".

1.2 Part number. The complete part number shall be as shown in the following example:

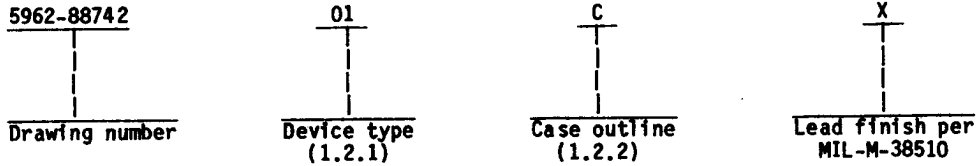

1.2.1 Device type. The device type shall identify the circuit function as follows:

Device type	Generic number	Circuit function
01	54ALS1035	Hex noninverting buffers with open collector outputs

1.2.2 Case outlines. The case outlines shall be as designated in appendix C of MIL-M-38510, and as follows:

Outline letter	Case outline
C	D-1 (14-Lead, .785" x .310" x .200"), dual-in-line package
D	F-2 (14-Lead, .390" x .260" x .085"), flat package
2	C-2 (20-terminal, .358" x .358" x .100"), square chip carrier package

1.3 Absolute maximum ratings.

Supply voltage range	-0.5 V dc minimum to +7.0 V dc maximum
Input voltage range	-1.5 V dc at -18 mA to +7.0 V dc
Storage temperature range	-65°C to +150°C
Lead temperature (soldering, 10 seconds)	+300°C
Junction temperature (T <sub>j</sub> )	+175°C
Maximum power dissipation (P <sub>D</sub> ) 1/	77 mW
Thermal resistance, junction-to-case (θ <sub>JC</sub> )	See MIL-M-38510, appendix C

1.4 Recommended operating conditions.

Supply voltage range (V <sub>CC</sub> )	+4.5 V dc minimum to +5.5 V dc maximum
Minimum high level input voltage (V <sub>IH</sub> )	2.0 V dc
Maximum low level input voltage (V <sub>IL</sub> ):	
T <sub>C</sub> = +125°C	0.7 V dc
T <sub>C</sub> = -55°C	0.8 V dc
T <sub>C</sub> = +25°C	0.7 V dc
Maximum high level output voltage (V <sub>OH</sub> )	5.5 V dc
Maximum low level output current (I <sub>OL</sub> )	12 mA
Case operating temperature range (T <sub>C</sub> )	-55°C to +125°C

1/ Maximum power dissipation is defined as V<sub>CC</sub> x I<sub>CC</sub>.

<b>STANDARDIZED MILITARY DRAWING</b> DEFENSE ELECTRONICS SUPPLY CENTER DAYTON, OHIO 45444	SIZE <b>A</b>	5962-88742
	REVISION LEVEL	SHEET <b>2</b>

**2. APPLICABLE DOCUMENTS**

2.1 Government specification and standard. Unless otherwise specified, the following specification and standard, of the issue listed in that issue of the Department of Defense Index of Specifications and Standards specified in the solicitation, form a part of this drawing to the extent specified herein.

**SPECIFICATION**

**MILITARY**

MIL-M-38510 - Microcircuits, General Specification for.

**STANDARD**

**MILITARY**

MIL-STD-883 - Test Methods and Procedures for Microelectronics.

(Copies of the specification and standard required by manufacturers in connection with specific acquisition functions should be obtained from the contracting activity or as directed by the contracting activity.)

2.2 Order of precedence. In the event of a conflict between the text of this drawing and the references cited herein, the text of this drawing shall take precedence.

**3. REQUIREMENTS**

3.1 Item requirements. The individual item requirements shall be in accordance with 1.2.1 of MIL-STD-883, "Provisions for the use of MIL-STD-883 in conjunction with compliant non-JAN devices" and as specified herein.

3.2 Design, construction, and physical dimensions. The design, construction, and physical dimensions shall be as specified in MIL-M-38510 and herein.

3.2.1 Terminal connections. The terminal connections shall be as specified on figure 1.

3.2.2 Truth table. The truth table shall be as specified on figure 2.

3.2.3 Test circuit and switching waveforms. The test circuit and switching waveforms shall be as specified on figure 3.

3.2.4 Case outlines. The case outlines shall be in accordance with 1.2.2 herein.

3.3 Electrical performance characteristics. Unless otherwise specified, the electrical performance characteristics are as specified in table I and apply over the full case operating temperature range.

3.4 Marking. Marking shall be in accordance with MIL-STD-883 (see 3.1 herein). The part shall be marked with the part number listed in 1.2 herein. In addition, the manufacturer's part number may also be marked as listed in 6.4 herein.

<b>STANDARDIZED MILITARY DRAWING</b> DEFENSE ELECTRONICS SUPPLY CENTER DAYTON, OHIO 45444	SIZE <b>A</b>		5962-88742
		REVISION LEVEL	SHEET 3

TABLE I. Electrical performance characteristics.						
Test	Symbol	Conditions -55°C < T <sub>C</sub> < +125°C unless otherwise specified	1/ Group A subgroups	Limits		Unit
				Min	Max	
Low level output voltage	V <sub>OL</sub>	V <sub>CC</sub> = 4.5 V V <sub>IH</sub> = 2.0 V I <sub>OL</sub> = 12 mA	V <sub>IL</sub> at: +125°C = 0.7 V -55°C = 0.8 V +25°C = 0.7 V	1, 2, 3		0.4 V
High level output current	I <sub>OH</sub>	V <sub>CC</sub> = 4.5 V	V <sub>OH</sub> = 5.5 V	1, 2, 3		0.1 mA
Input clamp voltage	V <sub>IC</sub>	V <sub>CC</sub> = 4.5 V	I <sub>IN</sub> = -18 mA	1, 2, 3		-1.5 V
Low level input current	I <sub>IL</sub>	V <sub>CC</sub> = 5.5 V Unused inputs ≥ 4.5 V	V <sub>IN</sub> = 0.4 V	1, 2, 3		-0.1 mA
High level input voltage	I <sub>IH1</sub>	V <sub>CC</sub> = 5.5 V Unused inputs = 0.0 V	V <sub>IN</sub> = 2.7 V	1, 2, 3		20 μA
	I <sub>IH2</sub>	V <sub>CC</sub> = 5.5 V Unused inputs = 0.0 V	V <sub>IN</sub> = 7.0 V	1, 2, 3		0.1 mA
Supply current	I <sub>CCH</sub>	V <sub>CC</sub> = 5.5 V	V <sub>IN</sub> = 4.5 V	1, 2, 3		6 mA
	I <sub>CCL</sub>	V <sub>CC</sub> = 5.5 V	V <sub>IN</sub> = 0.0 V			14
Functional tests		See 4.3.1c	3/	7, 8		
Propagation delay time, from A to Y	t <sub>PLH</sub>	V <sub>CC</sub> = 4.5 to 5.5 V C <sub>L</sub> = 50 pF R <sub>L</sub> = 680Ω		9, 10, 11	5	35 ns
	t <sub>PHL</sub>	See figure 3	4/		2	14

1/ Unused inputs that do not directly control the pin under test must be > 2.5 V or < 0.4 V. No unused inputs shall exceed 5.5 V or go less than 0.0 V. No inputs shall be floated.

2/ All outputs must be tested. In the case where only one input at V<sub>IL</sub> maximum or V<sub>IH</sub> minimum produces the proper output state, the test must be performed with each input being selected as the V<sub>IL</sub> maximum or V<sub>IH</sub> minimum input.

3/ Functional tests shall be conducted at input test conditions of GND ≤ V<sub>IL</sub> ≤ V<sub>OL</sub> and V<sub>OH</sub> ≤ V<sub>IH</sub> ≤ V<sub>CC</sub>.

4/ Propagation delay limits are based on single output switching. Unused inputs = 3.5 V or ≤ 0.3 V.

<b>STANDARDIZED MILITARY DRAWING</b> DEFENSE ELECTRONICS SUPPLY CENTER DAYTON, OHIO 45444	SIZE <b>A</b>	5962-88742
	REVISION LEVEL	SHEET 4

3.5 Certificate of compliance. A certificate of compliance shall be required from a manufacturer in order to be listed as an approved source of supply in 6.4. The certificate of compliance submitted to DESC-ECS prior to listing as an approved source of supply shall state that the manufacturer's product meets the requirements of MIL-STD-883 (see 3.1 herein) and the requirements herein.

3.6 Certificate of conformance. A certificate of conformance as required in MIL-STD-883 (see 3.1 herein) shall be provided with each lot of microcircuits delivered to this drawing.

3.7 Notification of change. Notification of change to DESC-ECS shall be required in accordance with MIL-STD-883 (see 3.1 herein).

3.8 Verification and review. DESC, DESC's agent, and the acquiring activity retain the option to review the manufacturer's facility and applicable required documentation. Offshore documentation shall be made available onshore at the option of the reviewer.

4. QUALITY ASSURANCE PROVISIONS

4.1 Sampling and inspection. Sampling and inspection procedures shall be in accordance with section 4 of MIL-M-38510 to the extent specified in MIL-STD-883 (see 3.1 herein).

4.2 Screening. Screening shall be in accordance with method 5004 of MIL-STD-883, and shall be conducted on all devices prior to quality conformance inspection. The following additional criteria shall apply:

a. Burn-in test, method 1015 of MIL-STD-883.

(1) Test condition A or D using the circuit submitted with the certificate of compliance (see 3.5 herein).

(2)  $T_A = +125^\circ\text{C}$ , minimum.

b. Interim and final electrical test parameters shall be as specified in table II herein, except interim electrical parameter tests prior to burn-in are optional at the discretion of the manufacturer.

4.3 Quality conformance inspection. Quality conformance inspection shall be in accordance with method 5005 of MIL-STD-883 including groups A, B, C, and D inspections. The following additional criteria shall apply.

4.3.1 Group A inspection.

a. Tests shall be as specified in table II herein.

b. Subgroups 4, 5, and 6 in table I, method 5005 of MIL-STD-883 shall be omitted.

c. Subgroups 7 and 8 shall verify the truth table as specified on figure 2.

<b>STANDARDIZED MILITARY DRAWING</b> DEFENSE ELECTRONICS SUPPLY CENTER DAYTON, OHIO 45444	<b>SIZE</b> <b>A</b>		5962-88742
		<b>REVISION LEVEL</b>	<b>SHEET</b> 5

Case outlines	C and D	2
Terminal number	Terminal symbol	
1	1A	NC
2	1Y	1A
3	2A	1Y
4	2Y	2A
5	3A	NC
6	3Y	2Y
7	GND	NC
8	4Y	3A
9	4A	3Y
10	5Y	GND
11	5A	NC
12	6Y	4Y
13	6A	4A
14	VCC	5Y
15	---	NC
16	---	5A
17	---	NC
18	---	6Y
19	---	6A
20	---	VCC

NC = no connection

FIGURE 1. Terminal connections

Input A	Output Y
H	H
L	L

H = High level voltage  
L = Low level voltage

FIGURE 2. Truth table

<b>STANDARDIZED MILITARY DRAWING</b> DEFENSE ELECTRONICS SUPPLY CENTER DAYTON, OHIO 45444	SIZE <b>A</b>		5962-88742
		REVISION LEVEL	SHEET 6

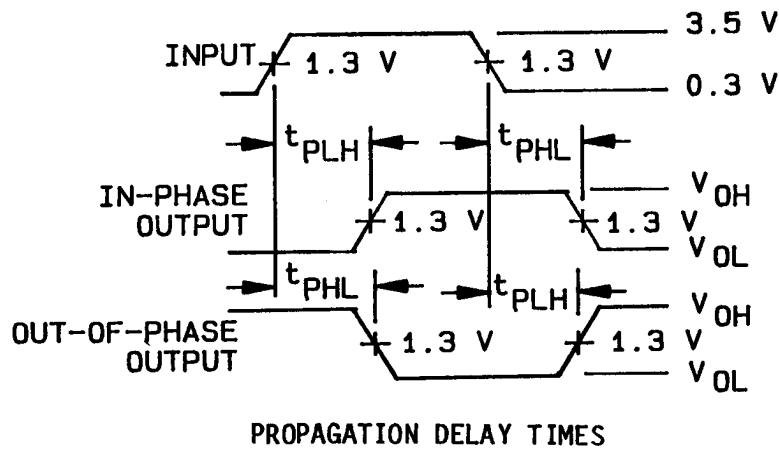
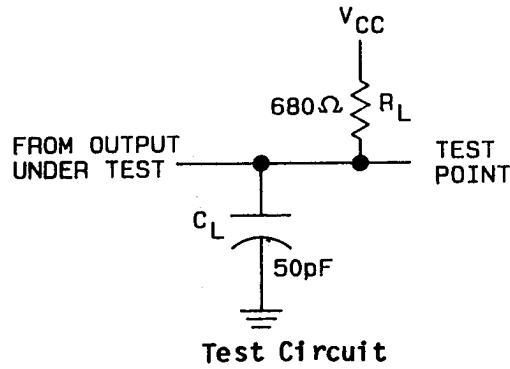

**NOTES:**

1.  $C_L$  includes probe and jig capacitance.
2. All input pulses have the following characteristics:  $PRR \leq 10$  MHz, duty cycle = 50%,  $t_r = t_f = 3$  ns  $\pm 1$  ns.
3. The outputs are measured one at a time with one input transition per measurement.

FIGURE 3. Test circuit and switching waveforms.

<b>STANDARDIZED MILITARY DRAWING</b> DEFENSE ELECTRONICS SUPPLY CENTER DAYTON, OHIO 45444	SIZE <b>A</b>	5962-88742
	REVISION LEVEL	SHEET 7

**4.3.2 Groups C and D inspections.**

- a. End-point electrical parameters shall be as specified in table II herein.
- b. Steady-state life test conditions, method 1005 of MIL-STD-883.
  - (1) Test condition A or D using the circuit submitted with the certificate of compliance (see 3.5 herein).
  - (2)  $T_A = +125^{\circ}\text{C}$ , minimum.
  - (3) Test duration: 1,000 hours except as permitted by method 1005 of MIL-STD-883.

**TABLE II. Electrical test requirements.**

MIL-STD-883 test requirements	Subgroups (per method 5005, table I)
Interim electrical parameters (method 5004)	---
Final electrical test parameters (method 5004)	1*,2,3,7,8,9, 10,11
Group A test requirements (method 5005)	1,2,3,7,8,9, 10,11
Group C and D end-point electrical parameters (method 5005)	1,2,3

\* PDA applies to subgroup 1.

**5. PACKAGING**

**5.1 Packaging requirements.** The requirements for packaging shall be in accordance with MIL-M-38510.

**6. NOTES**

**6.1 Intended use.** Microcircuits conforming to this drawing are intended for use when military specifications do not exist and qualified military devices that will perform the required function are not available for OEM application. When a military specification exists and the product covered by this drawing has been qualified for listing on QPL-38510, the device specified herein will be inactivated and will not be used for new design. The QPL-38510 product shall be the preferred item for all applications.

**6.2 Replaceability.** Microcircuits covered by this drawing will replace the same generic device covered by a contractor-prepared specification or drawing.

**6.3 Comments.** Comments on this drawing should be directed to DESC-ECS, Dayton, Ohio 45444, or telephone 513-296-5375.

<b>STANDARDIZED MILITARY DRAWING</b> DEFENSE ELECTRONICS SUPPLY CENTER DAYTON, OHIO 45444	SIZE <b>A</b>	5962-88742
	REVISION LEVEL	SHEET 8



查询"5962-8874201DA"供应商

6.4 **Approved source of supply.** An approved source of supply is listed herein. Additional sources will be added as they become available. The vendor listed herein has agreed to this drawing and a certificate of compliance (see 3.5 herein) has been submitted to DESC-ECS.

Military drawing part number	Vendor CAGE number	Vendor similar part number <u>1/</u>	Replacement military specification part number
5962-8874201CX	01295	SNJ54ALS1035J	M38510/38401CX
5962- 8874201DX	01295	SNJ54ALS1035W	M38510/38401DX
5962-88742012X	01295	SNJ54ALS1035FK	M38510/384012X

1/ **Caution.** Do not use this number for item acquisition. Items acquired to this number may not satisfy the performance requirements of this drawing.

Vendor CAGE number

01295

Vendor name and address

Texas Instruments, Incorporated  
P.O. Box 6448  
Midland, TX 79711

<b>STANDARDIZED MILITARY DRAWING</b> DEFENSE ELECTRONICS SUPPLY CENTER DAYTON, OHIO 45444	SIZE <b>A</b>		5962-88742
		REVISION LEVEL	SHEET 9

DESC FORM 193A  
SEP 87

☆ U. S. GOVERNMENT PRINTING OFFICE: 1986-550-547