

AC Motor 146DF0182000" 供应商

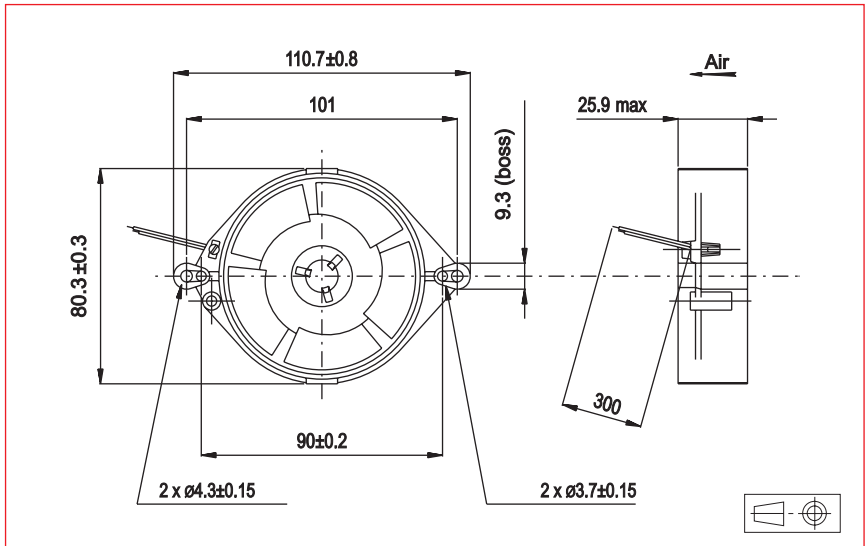

#### Approvals



#### Life expectancy

L-10 LIFE AT 40°C:  
80 000 hours

#### AC Motor

Electrical protection: impedance protected  
Housing material: zamak  
Impeller material: plastic UL 94 VO  
Weight: 300 g  
Bearing system: ball bearings

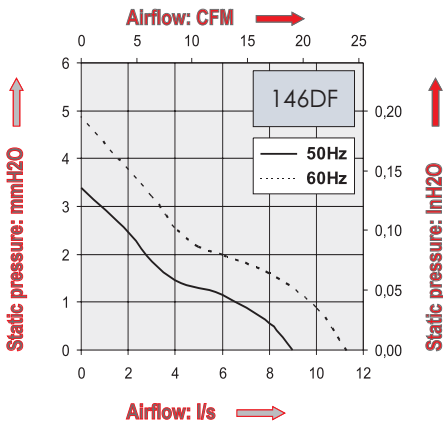

Part Number	Nominal voltage	Airflow	Noise level	Nominal speed	Frequency	Phases	Capacitor	Input Power	Nominal current	Starting current	Connection type		Operating temperature	
	V										l/s	dB(A)	RPM	Hz
146DF0181000	208-240	9	26	2500	50	1		11	60	70	X		-10	70
		11	32	3100	60	1		9	50	60	X		-10	70
146DF0182000	115	9	26	2500	50	1		10	105	120	X		-10	70
		11	32	3100	60	1		8	90	110	X		-10	70

#### Additional versions:

Shock and vibration protected - salt spray protected - marine specifications - wide temperature range  
IP54: consult factory

#### Accessories:

Refer to Accessories leaflet