

REVISIONS												
LTR	DESCRIPTION	DATE	APPROVED									

REV												
PAGE												
REV STATUS OF PAGES	REV											
	PAGES	1	2	3	4	5	6	7	8	9	10	11

Defense Electronics Supply Center Dayton, Ohio  Original date of drawing: 13 JUNE 1988  AMSC N/A	PREPARED BY <i>Marcia B. Kelleher</i>	<b>MILITARY DRAWING</b> This drawing is available for use by all Departments and Agencies of the Department of Defense  TITLE: MICROCIRCUIT, LINEAR, 8-CHANNEL LATCHABLE MULTIPLEXER, MONOLITHIC SILICON
	CHECKED BY <i>Ray Monnin</i>	
	APPROVED BY <i>[Signature]</i>	DWG NO. 5962-87689
	SIZE A      CODE IDENT. NO. 67268	PAGE 1 OF 12

5962-E584

DISTRIBUTION STATEMENT A. Approved for public release; distribution is unlimited.  
 DESC FORM 193  
 MAY 86

1. SCOPE

1.1 Scope. This drawing describes device requirements for class B microcircuits in accordance with 1.2.1 of MIL-STD-883, "Provisions for the use of MIL-STD-883 in conjunction with compliant non-JAN devices".

1.2 Part number. The complete part number shall be as shown in the following example:

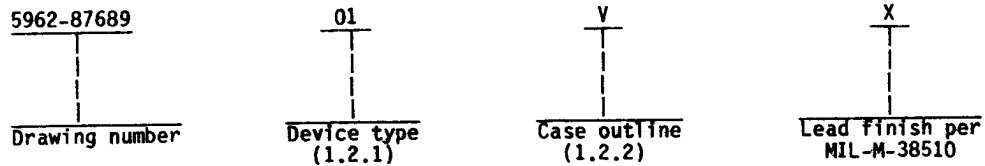

1.2.1 Device type. The device type shall identify the circuit function as follows:

Device type	Generic number	Circuit function
01	DG528	8-channel latching multiplexer

1.2.2 Case outline. The case outline shall be as designated in appendix C of MIL-M-38510, and as follows:

Outline letter	Case outline
V	D-6 (18-lead, .960" x .310" x .200"), dual-in-line package

1.3 Absolute maximum ratings.

Supply voltage between V+ and V- - - - -	44 V dc
Supply voltage between V- and GND - - - -	25 V dc
Digital inputs between V <sub>S</sub> , V <sub>D</sub> , and V- - - -	-2 V to (V+ +2 V) or 20 mA
Current (any terminal except S or D) - - - -	30 mA
Continuous current, S or D - - - - -	20 mA
Peak current, S or D (Pulsed at 1 ms, 10 percent duty cycle maximum) -	40 mA
Thermal resistance, junction to ambient (θ <sub>JA</sub> ) - - -	+75°C/W
Thermal resistance, junction to case (θ <sub>JC</sub> ) - - - -	See MIL-M-38510, appendix C
Storage temperature - - - - -	-65°C to +150°C
Lead temperature (soldering, 60 seconds) - - - -	+300°C
Power dissipation (P <sub>D</sub> ) - - - - -	900 mW
Derate 12 mW/°C above T <sub>A</sub> = +75°C	

1.4 Recommended operating conditions.

Ambient operating temperature (T <sub>A</sub> ) - - - - -	-55°C to 125°C
---	----------------

<b>STANDARDIZED MILITARY DRAWING</b> DEFENSE ELECTRONICS SUPPLY CENTER DAYTON, OHIO 45444	SIZE <b>A</b>	5962-87689
	REVISION LEVEL	SHEET 2

2. APPLICABLE DOCUMENTS

2.1 Government specification and standard. Unless otherwise specified, the following specification and standard, of the issue listed in that issue of the Department of Defense Index of Specifications and Standards specified in the solicitation, form a part of this drawing to the extent specified herein.

SPECIFICATION

MILITARY

MIL-M-38510 - Microcircuits, General Specification for.

STANDARD

MILITARY

MIL-STD-883 - Test Methods and Procedures for Microelectronics.

(Copies of the specification and standard required by manufacturers in connection with specific acquisition functions should be obtained from the contracting activity or as directed by the contracting activity.)

2.2 Order of precedence. In the event of a conflict between the text of this drawing and the references cited herein, the text of this drawing shall take precedence.

3. REQUIREMENTS

3.1 Item requirements. The individual item requirements shall be in accordance with 1.2.1 of MIL-STD-883, "Provisions for the use of MIL-STD-883 in conjunction with compliant non-JAN devices" and as specified herein.

3.2 Design, construction, and physical dimensions. The design, construction, and physical dimensions shall be as specified in MIL-M-38510 and herein.

3.2.1 Terminal connections and truth table. The terminal connections and truth table shall be as specified on figure 1.

3.2.2 Timing diagrams. The timing diagrams shall be as specified on figures 2, 3, 4, and 5.

3.2.3 Case outline. The case outline shall be in accordance with 1.2.2 herein.

3.3 Electrical performance characteristics. Unless otherwise specified, the electrical performance characteristics are as specified in table I and apply over the full ambient operating temperature range.

3.4 Marking. Marking shall be in accordance with MIL-STD-883 (see 3.1 herein). The part shall be marked with the part number listed in 1.2 herein. In addition, the manufacturer's part number may also be marked as listed in 6.4 herein.

3.5 Certificate of compliance. A certificate of compliance shall be required from a manufacturer in order to be listed as an approved source of supply in 6.4. The certificate of compliance submitted to DESC-ECS prior to listing as an approved source of supply shall state that the manufacturer's product meets the requirements of MIL-STD-883 (see 3.1 herein) and the requirements herein.

3.6 Certificate of conformance. A certificate of conformance as required in MIL-STD-883 (see 3.1 herein) shall be provided with each lot of microcircuits delivered to this drawing.

<b>STANDARDIZED MILITARY DRAWING</b> DEFENSE ELECTRONICS SUPPLY CENTER DAYTON, OHIO 45444	SIZE <b>A</b>		5962-87689
		REVISION LEVEL	SHEET 3

TABLE I. Electrical performance characteristics.

Test	Symbol	Conditions -55°C < T <sub>A</sub> < +125°C unless otherwise specified 1/	Group A subgroups	Limits		Unit
				Min	Max	
Analog signal range	V <sub>ANALOG</sub>		1,2,3	-15	+15	V
Drain-source "ON" resistance	R <sub>DS(ON)</sub>	V <sub>D</sub> = ±10 V, V <sub>AL</sub> = 0.8 V, I <sub>S</sub> = -200 μA, V <sub>AH</sub> = 2.4 V, Sequence each switch ON	1		400	Ω
			2,3		500	
Source "OFF" leakage current	I <sub>S(OFF)</sub>	V <sub>S</sub> = ±10 V V <sub>D</sub> = ±10 V V <sub>EN</sub> = 0 V	1	-1	+1	nA
			2,3	-50	+50	
Drain "OFF" leakage current	I <sub>D(OFF)</sub>		1	-10	+10	
			2,3	-200	+200	
Drain "ON" leakage current	I <sub>D(ON)</sub> <u>2/</u>	V <sub>S</sub> (all) = V <sub>D</sub> = ±10 V Sequence each switch ON V <sub>AL</sub> = 0.8 V, V <sub>AH</sub> = 2.4 V	1	-10	+10	
			2,3	-200	+200	
Logic input current, input voltage high	I <sub>AH</sub>	V <sub>A</sub> = 2.4 V	1	-10		μA
			2,3	-30		
		V <sub>A</sub> = 15 V	1		+10	
			2,3		+30	
Logic input current, input voltage low	I <sub>AL</sub>	V <sub>EN</sub> = 0 V, 2.4 V, V <sub>A</sub> (all) = 0 V, $\overline{R_S}$ = 0 V	1	-10		
			2,3	-30		
Positive supply current	I <sub>CC+</sub>	V <sub>EN</sub> = 0 V, V <sub>A</sub> (all) = 0 V	1		2.5	mA
			2,3		4	
Negative supply current	I <sub>CC-</sub>		1	-1.5		
			2,3	-4		

See footnotes at end of table.

<b>STANDARDIZED MILITARY DRAWING</b> DEFENSE ELECTRONICS SUPPLY CENTER DAYTON, OHIO 45444	SIZE <b>A</b>		5962-87689
		REVISION LEVEL	SHEET 4

TABLE I. Electrical performance characteristics.

Test	Symbol	Conditions -55°C < T <sub>A</sub> < +125°C unless otherwise specified 1/	Group A subgroups	Limits		Unit
				Min	Max	
Functional test		See 4.3.1c	7,8			
Switching time	t <sub>THL</sub> , t <sub>TLH</sub>	See figure 2	9,10,11		1	μs
Enable and write turn ON time	t <sub>on</sub> (EN,WR)	See figures 3 and 4	9,10,11		1	
Enable and reset turn OFF time	t <sub>off</sub> (EN,RS)	See figures 3 and 5	9,10,11		1	

1/ V+ = 15 V, V- = -15 V, GND = 0 V, WR = 0 V, RS = 2.4 V; period of reset (RS) pulse must be at least 50 μs during or after power ON.

2/ I<sub>D</sub>(ON) is leakage from driver into "ON" switch.

TABLE II. Electrical test requirements.

MIL-STD-883 test requirements	Subgroups (per method 5005, table I)
Interim electrical parameters (method 5004)	---
Final electrical test parameters (method 5004)	1*,2,3,7,8, 9,10**,11**
Group A test requirements (method 5005)	1,2,3,7,8, 9,10**,11**
Groups C and D end-point electrical parameters (method 5005)	1,2,3

- \* PDA applies to subgroup 1.
- \*\* Subgroups 10 and 11, if not tested, shall be guaranteed to the limits specified in table I.

3.7 Notification of change. Notification of change to DESC-ECS shall be required in accordance with MIL-STD-883 (see 3.1 herein).

3.8 Verification and review. DESC, DESC's agent, and the acquiring activity retain the option to review the manufacturer's facility and applicable required documentation. Offshore documentation shall be made available onshore at the option of the reviewer.

<b>STANDARDIZED MILITARY DRAWING</b> DEFENSE ELECTRONICS SUPPLY CENTER DAYTON, OHIO 45444	SIZE <b>A</b>		5962-87689
		REVISION LEVEL	SHEET 5

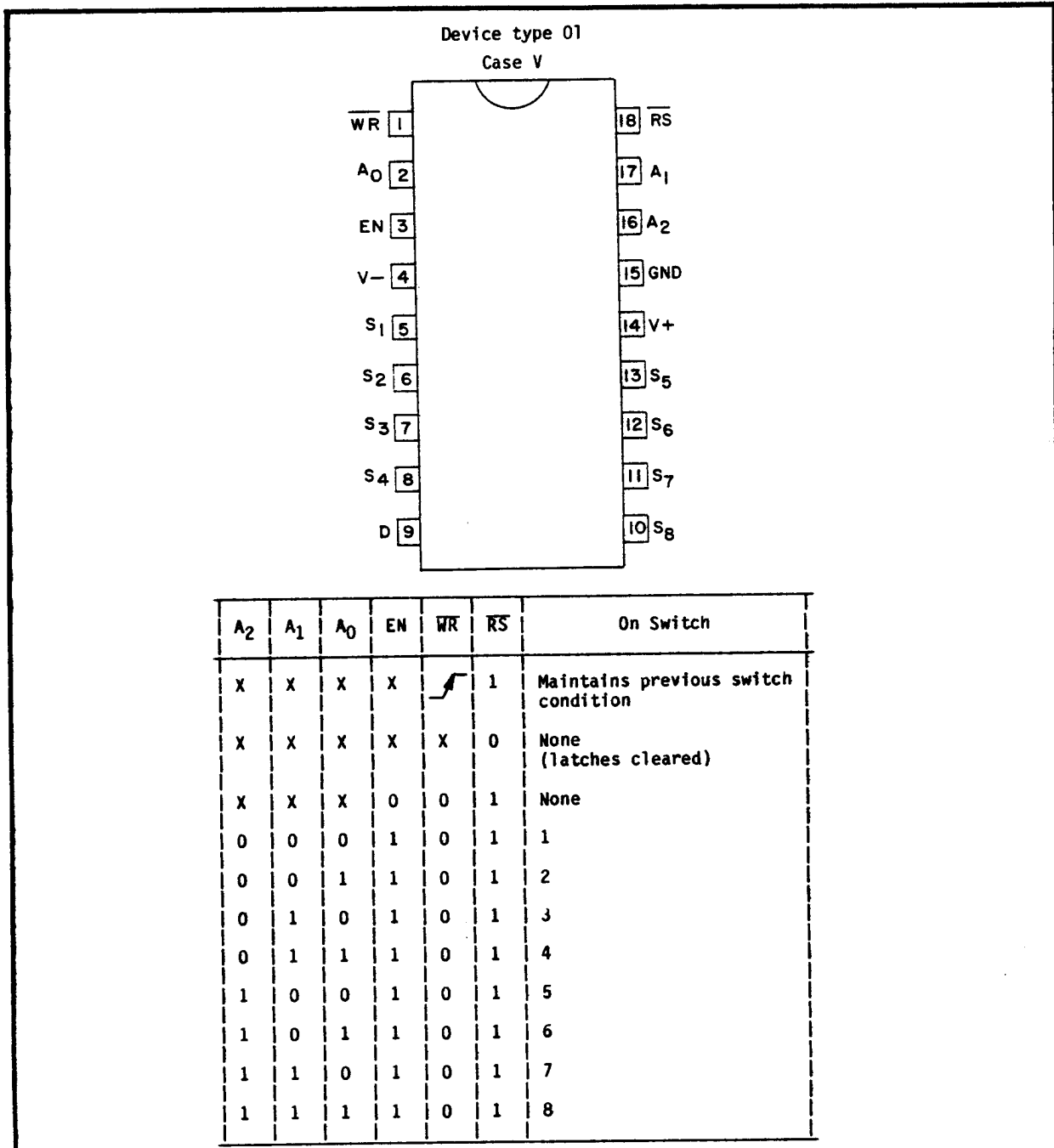

FIGURE 1. Terminal connections and truth table.

<b>STANDARDIZED MILITARY DRAWING</b> DEFENSE ELECTRONICS SUPPLY CENTER DAYTON, OHIO 45444	SIZE <b>A</b>	5962-87689
	REVISION LEVEL	SHEET 6

DESC FORM 193A  
SEP 87

☆ U.S. GOVERNMENT PRINTING OFFICE: 1987 - 746-129-6093

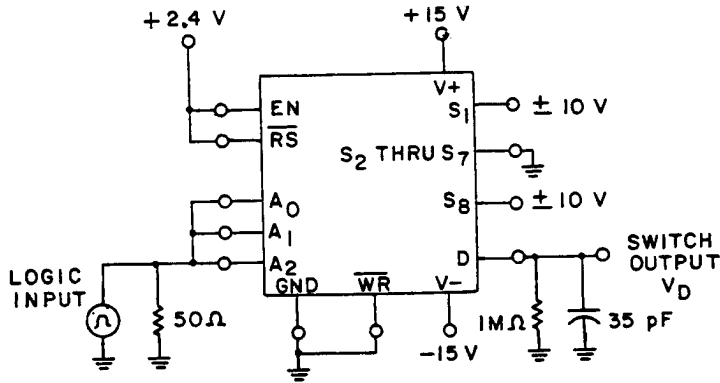
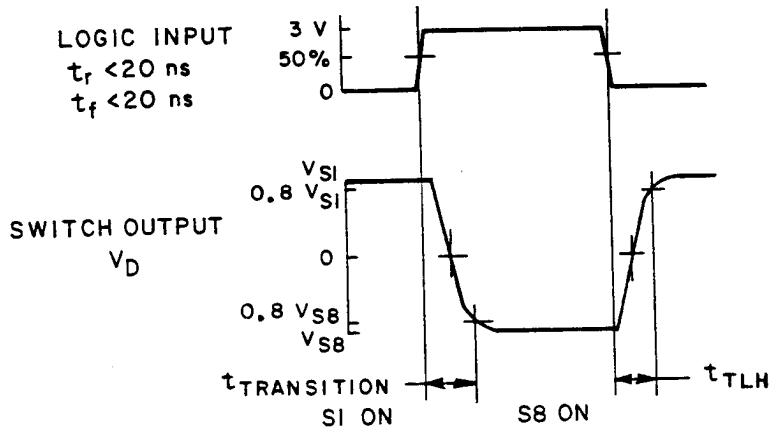

FIGURE 2. Transition time test circuit.

<b>STANDARDIZED                  MILITARY DRAWING</b> DEFENSE ELECTRONICS SUPPLY CENTER DAYTON, OHIO 45444	SIZE <b>A</b>	5962-87689
	REVISION LEVEL	SHEET 7

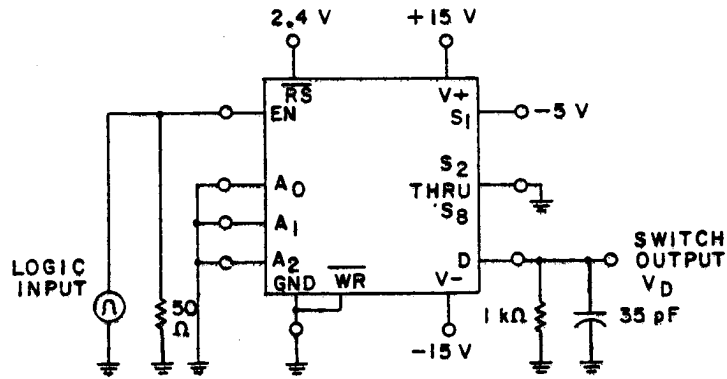
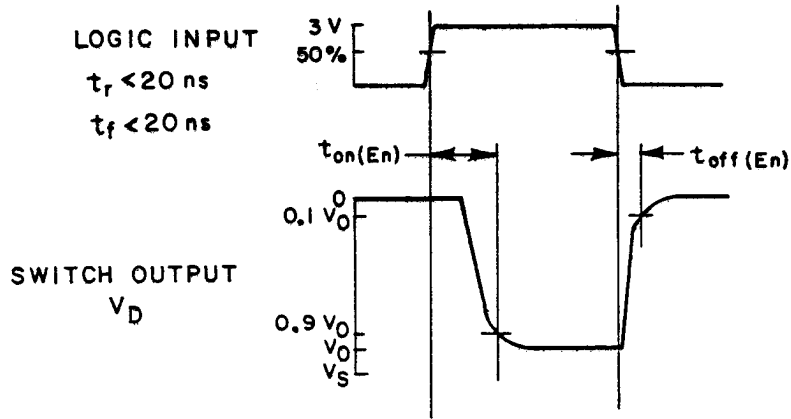

FIGURE 3. Enable  $t_{on}/t_{off}$  time.

<b>STANDARDIZED                  MILITARY DRAWING</b> DEFENSE ELECTRONICS SUPPLY CENTER DAYTON, OHIO 45444	SIZE <b>A</b>	5962-87689
	REVISION LEVEL	SHEET 8



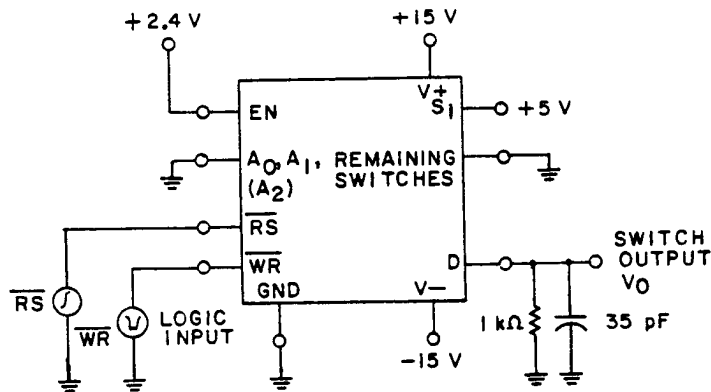
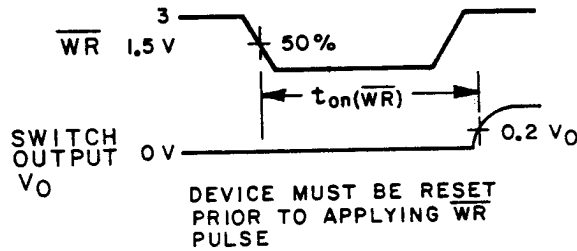

FIGURE 4. Write turn-on time  $t_{on}(\overline{WR})$ .

<b>STANDARDIZED MILITARY DRAWING</b> DEFENSE ELECTRONICS SUPPLY CENTER DAYTON, OHIO 45444	SIZE <b>A</b>	5962-87689	
		REVISION LEVEL	SHEET 9

DESC FORM 193A  
SEP 87

★ U.S. GOVERNMENT PRINTING OFFICE: 1967 - 748-129-60913

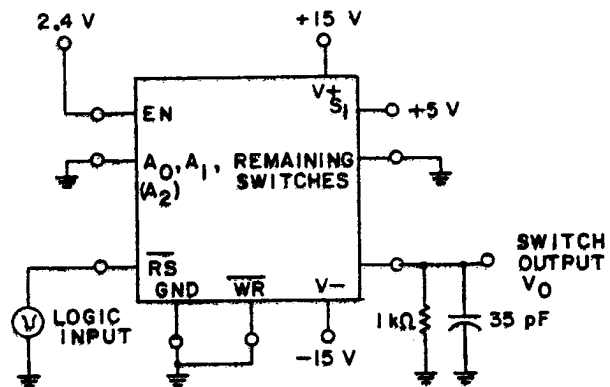
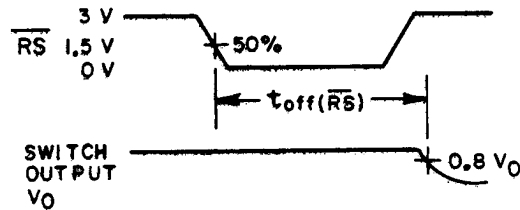

FIGURE 5. Reset turn-off time  $t_{off}(\overline{RS})$ .

<b>STANDARDIZED MILITARY DRAWING</b> DEFENSE ELECTRONICS SUPPLY CENTER DAYTON, OHIO 45444	SIZE <b>A</b>	5962-87689
	REVISION LEVEL	SHEET 10

DESC FORM 193A  
SEP 87

☆ U.S. GOVERNMENT PRINTING OFFICE: 1987 - 748-125-6093

4. QUALITY ASSURANCE PROVISIONS

4.1 Sampling and inspection. Sampling and inspection procedures shall be in accordance with section 4 of MIL-M-38510 to the extent specified in MIL-STD-883 (see 3.1 herein).

4.2 Screening. Screening shall be in accordance with method 5004 of MIL-STD-883, and shall be conducted on all devices prior to quality conformance inspection. The following additional criteria shall apply:

- a. Burn-in test, method 1015 of MIL-STD-883.
  - (1) Test condition A, C, or D using the circuit submitted with the certificate of compliance (see 3.5 herein).
  - (2)  $T_A = +125^\circ\text{C}$ , minimum.
- b. Interim and final electrical test parameters shall be as specified in table II herein, except interim electrical parameter tests prior to burn-in are optional at the discretion of the manufacturer.

4.3 Quality conformance inspection. Quality conformance inspection shall be in accordance with method 5005 of MIL-STD-883 including groups A, B, C, and D inspections. The following additional criteria shall apply.

4.3.1 Group A inspection.

- a. Tests shall be as specified in table II herein.
- b. Subgroups 4, 5, and 6 in table I, method 5005 of MIL-STD-883 shall be omitted.
- c. Subgroups 7 and 8 testing shall be sufficient to verify the truth table.

4.3.2 Groups C and D inspections.

- a. End-point electrical parameters shall be as specified in table II herein.
- b. Steady-state life test conditions, method 1005 of MIL-STD-883:
  - (1) Test condition A, C, or D using the circuit submitted with the certificate of compliance (see 3.5 herein).
  - (2)  $T_A = +125^\circ\text{C}$ , minimum.
  - (3) Test duration: 1,000 hours, except as permitted by method 1005 of MIL-STD-883.

5. PACKAGING

5.1 Packaging requirements. The requirements for packaging shall be in accordance with MIL-M-38510.

6. NOTES

6.1 Intended use. Microcircuits conforming to this drawing are intended for use when military specifications do not exist and qualified military devices that will perform the required function are not available for OEM application. When a military specification exists and the product covered by this drawing has been qualified for listing on QPL-38510, the device specified herein will be inactivated and will not be used for new design. The QPL-38510 product shall be the preferred item for all applications.

<b>STANDARDIZED MILITARY DRAWING</b> DEFENSE ELECTRONICS SUPPLY CENTER DAYTON, OHIO 45444	SIZE <b>A</b>	5962-87689
	REVISION LEVEL	SHEET 11

6.2 Replaceability. Microcircuits covered by this drawing will replace the same generic device covered by a contractor-prepared specification or drawing.

6.3 Comments. Comments on this drawing should be directed to DESC-ECS, Dayton, Ohio 45444, or telephone 513-296-5375.

6.4 Approved source of supply. An approved source of supply is listed herein. Additional sources will be added as they become available. The vendor listed herein has agreed to this drawing and a certificate of compliance (see 3.5 herein) has been submitted to DESC-ECS.

Military drawing part number	Vendor CAGE number	Vendor similar part number <u>1/</u>
5962-8768901VX	17856	DG528AK/883

1/ Caution. Do not use this number for item acquisition. Items acquired to this number may not satisfy the performance requirements of this drawing.

Vendor CAGE number

17856

Vendor name and address

Siliconix, Inc  
2201 Laurelwood Row  
Santa Clara, CA 95054

<b>STANDARDIZED MILITARY DRAWING</b> DEFENSE ELECTRONICS SUPPLY CENTER DAYTON, OHIO 45444	SIZE <b>A</b>		5962-87689
		REVISION LEVEL	SHEET 12

DESC FORM 193A  
SEP 87

☆ U.S. GOVERNMENT PRINTING OFFICE: 1987-549-086