

REVISIONS

LTR	DESCRIPTION	DATE (YR-MO-DA)	APPROVED
	<a href="#">查询"5962H9659601QCA"供应商</a>		

REV																				
SHEET																				
REV																				
SHEET																				
REV STATUS OF SHEETS	REV																			
	SHEET	1	2	3	4	5	6	7	8	9	10	11	12	13						

<p>PMIC N/A</p> <p><b>STANDARD MICROCIRCUIT DRAWING</b></p> <p>THIS DRAWING IS AVAILABLE FOR USE BY ALL DEPARTMENTS AND AGENCIES OF THE DEPARTMENT OF DEFENSE</p> <p>AMSC N/A</p>	<p>PREPARED BY Larry T. Gauder</p>	<p><b>DEFENSE ELECTRONICS SUPPLY CENTER</b> DAYTON, OHIO 45444</p>		
	<p>CHECKED BY Thanh V. Nguyen</p>			
	<p>APPROVED BY Monica L. Poelking</p>	<p>MICROCIRCUIT, DIGITAL, RADIATION HARDENED, ADVANCED CMOS, DUAL 4-INPUT NOR GATE, MONOLITHIC SILICON</p>		
	<p>DRAWING APPROVAL DATE 96-04-19</p>			
	<p>REVISION LEVEL</p>	<p>SIZE <b>A</b></p>	<p>CAGE CODE <b>67268</b></p>	<p><b>5962-96596</b></p>
		<p>SHEET 1</p>	<p>OF</p>	<p>13</p>

DESC FORM 193  
JUL 94

DISTRIBUTION STATEMENT A. Approved for public release; distribution is unlimited.

5962-E406-96

■ 9004708 0021517 003 ■

1. SCOPE

1.1 Scope. This drawing documents the product assurance class levels consisting of high reliability (device classes Q and M) and space application (device class V). A choice of case outlines and lead finishes are available and are reflected in the Part or Identifying Number (PIN). When available, a choice of Radiation Hardness Assurance (RHA) levels are reflected in the PIN.

1.2 PIN. The PIN is as shown in the following example:

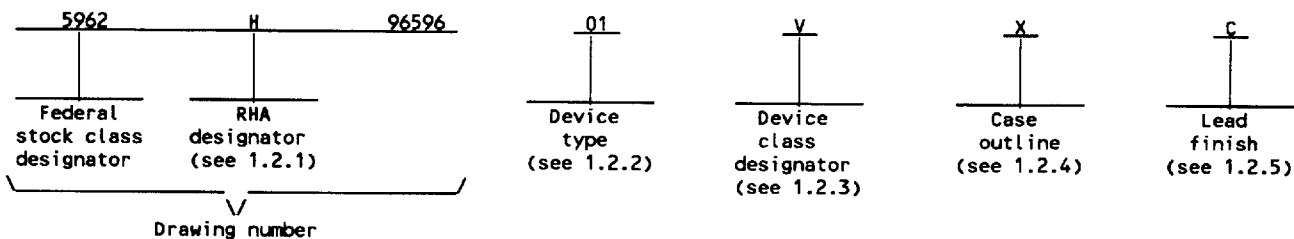

1.2.1 RHA designator. Device classes Q and V RHA marked devices meet the MIL-PRF-38535 specified RHA levels and are marked with the appropriate RHA designator. Device class M RHA marked devices meet the MIL-PRF-38535, appendix A specified RHA levels and are marked with the appropriate RHA designator. A dash (-) indicates a non-RHA device.

1.2.2 Device type(s). The device type(s) identify the circuit function as follows:

<u>Device type</u>	<u>Generic number</u>	<u>Circuit function</u>
01	54ACS4002	Radiation hardened, dual 4-input NOR gate

1.2.3 Device class designator. The device class designator is a single letter identifying the product assurance level as follows:

<u>Device class</u>	<u>Device requirements documentation</u>
M	Vendor self-certification to the requirements for MIL-STD-883 compliant, non-JAN class level B microcircuits in accordance with MIL-PRF-38535, appendix A
Q or V	Certification and qualification to MIL-PRF-38535

1.2.4 Case outline(s). The case outline(s) are as designated in MIL-STD-1835 and as follows:

<u>Outline letter</u>	<u>Descriptive designator</u>	<u>Terminals</u>	<u>Package style</u>
C	GDIP1-T14 or CDIP2-T14	14	Dual-in-line package
X	CDFP3-F14	14	Flat package

1.2.5 Lead finish. The lead finish is as specified in MIL-PRF-38535 for device classes Q and V or MIL-PRF-38535, appendix A for device class M.

STANDARD MICROCIRCUIT DRAWING DEFENSE ELECTRONICS SUPPLY CENTER DAYTON, OHIO 45444	SIZE <b>A</b>		<b>5962-96596</b>
		REVISION LEVEL	SHEET <b>2</b>

1.3 Absolute maximum ratings. 1/ 2/ 3/

Supply voltage range ( $V_{DD}$ )	-0.3 V dc to +7.0 V dc
DC output voltage range ( $V_{OUT}$ )	-0.3 V dc to $V_{DD} + 0.3$ V dc
DC input voltage range ( $V_{IN}$ )	-0.3 V dc to $V_{DD} + 0.3$ V dc
DC input current, any one input ( $I_{IN}$ )	$\pm 10$ mA
Latch-up immunity current ( $I_{LU}$ )	$\pm 150$ mA
Storage temperature range ( $T_{STG}$ )	-65°C to +150°C
Lead temperature (soldering, 5 seconds)	+300°C
Thermal resistance, junction-to-case ( $\theta_{JC}$ )	See MIL-STD-1835
Junction temperature ( $T_J$ )	+175°C
Maximum package power dissipation ( $P_D$ )	1.0 W

1.4 Recommended operating conditions. 2/ 3/

Supply voltage range ( $V_{DD}$ )	+4.5 V dc to +5.5 V dc
Input voltage range ( $V_{IN}$ )	+0.0 V dc to $V_{DD}$
Output voltage range ( $V_{OUT}$ )	+0.0 V dc to $V_{DD}$
Case operating temperature range ( $T_C$ )	-55°C to +125°C
Maximum input rise and fall time at $V_{DD} = 4.5$ V ( $t_r, t_f$ )	1 ns/V 4/

1.5 Radiation features. 5/

Total dose	> $1 \times 10^6$ Rads (Si)
Single event phenomenon (SEP) effective linear energy threshold (LET) No upsets (see 4.4.4.4)	> 80 MeV/(mg/cm <sup>2</sup> )
Dose rate upset (20 ns pulse)	> $1 \times 10^9$ Rads (Si)/s
Latch-up	None
Dose rate survivability	> $1 \times 10^{12}$ Rads (Si)/s

2. APPLICABLE DOCUMENTS

2.1 Government specification, standards, and handbooks. The following specification, standards, and handbooks form a part of this drawing to the extent specified herein. Unless otherwise specified, the issues of these documents are those listed in the issue of the Department of Defense Index of Specifications and Standards (DoDISS) and supplement thereto, cited in the solicitation.

SPECIFICATION

MILITARY

MIL-PRF-38535 - Integrated Circuits, Manufacturing, General Specification for.

STANDARDS

MILITARY

MIL-STD-883 - Test Methods and Procedures for Microelectronics.  
 MIL-STD-973 - Configuration Management.  
 MIL-STD-1835 - Microcircuit Case Outlines.

HANDBOOKS

MILITARY

MIL-HDBK-103 - List of Standard Microcircuit Drawings (SMD's).  
 MIL-HDBK-780 - Standard Microcircuit Drawings.

(Unless otherwise indicated, copies of the specification, standards, and handbooks are available from the Standardization Document Order Desk, 700 Robbins Avenue, Building 4D, Philadelphia, PA 19111-5094.)

- 1/ Stresses above the absolute maximum rating may cause permanent damage to the device. Extended operation at the maximum levels may degrade performance and affect reliability.
- 2/ Unless otherwise noted, all voltages are referenced to  $V_{SS}$ .
- 3/ The limits for the parameters specified herein shall apply over the full specified  $V_{DD}$  range and case temperature range of -55°C to +125°C unless otherwise noted.
- 4/ Derate propagation delays by difference in rise time to switch point for  $t_r$  or  $t_f > 1$  ns/V.
- 5/ Radiation testing is performed on the standard evaluation circuit.

STANDARD MICROCIRCUIT DRAWING DEFENSE ELECTRONICS SUPPLY CENTER DAYTON, OHIO 45444	SIZE <b>A</b>		<b>5962-96596</b>
		REVISION LEVEL	SHEET <b>3</b>

DESC FORM 193A  
 JUL 94

9004708 0021519 986

2.2 Order of precedence. In the event of a conflict between the text of this drawing and the references cited herein, the text of this drawing takes precedence. Nothing in this document, however, supersedes applicable laws and regulations unless a specific exemption has been obtained.

### 3. REQUIREMENTS

3.1 Item requirements. The individual item requirements for device classes Q and V shall be in accordance with MIL-PRF-38535 and as specified herein or as modified in the device manufacturer's Quality Management (QM) plan. The modification in the QM plan shall not affect the form, fit, or function as described herein. The individual item requirements for device class M shall be in accordance with MIL-PRF-38535, appendix A for non-JAN class level B devices and as specified herein.

3.2 Design, construction, and physical dimensions. The design, construction, and physical dimensions shall be as specified in MIL-PRF-38535 and herein for device classes Q and V or MIL-PRF-38535, appendix A and herein for device class M.

3.2.1 Case outlines. The case outlines shall be in accordance with 1.2.4 herein.

3.2.2 Terminal connections. The terminal connections shall be as specified on figure 1.

3.2.3 Truth table. The truth table shall be as specified on figure 2.

3.2.4 Logic diagram. The logic diagram shall be as specified on figure 3.

3.2.5 Switching waveforms and test circuits. The switching waveforms and test circuits shall be as specified on figure 4.

3.2.6 Irradiation test connections. The irradiation test connections shall be as specified in table III.

3.3 Electrical performance characteristics and postirradiation parameter limits. Unless otherwise specified herein, the electrical performance characteristics and postirradiation parameter limits are as specified in table IA and shall apply over the full case operating temperature range.

3.4 Electrical test requirements. The electrical test requirements shall be the subgroups specified in table IIA. The electrical tests for each subgroup are defined in table IA.

3.5 Marking. The part shall be marked with the PIN listed in 1.2 herein. In addition, the manufacturer's PIN may also be marked as listed in MIL-HDBK-103. For packages where marking of the entire SMD PIN number is not feasible due to space limitations, the manufacturer has the option of not marking the "5962-" on the device. For RHA product using this option, the RHA designator shall still be marked. Marking for device classes Q and V shall be in accordance with MIL-PRF-38535. Marking for device class M shall be in accordance with MIL-PRF-38535, appendix A.

3.5.1 Certification/compliance mark. The certification mark for device classes Q and V shall be a "QML" or "Q" as required in MIL-PRF-38535. The compliance mark for device class M shall be a "C" as required in MIL-PRF-38535, appendix A.

3.6 Certificate of compliance. For device classes Q and V, a certificate of compliance shall be required from a QML-38535 listed manufacturer in order to supply to the requirements of this drawing (see 6.6.1 herein). For device class M, a certificate of compliance shall be required from a manufacturer in order to be listed as an approved source of supply in MIL-HDBK-103 (see 6.6.2 herein). The certificate of compliance submitted to DESC-EC prior to listing as an approved source of supply for this drawing shall affirm that the manufacturer's product meets, for device classes Q and V, the requirements of MIL-PRF-38535 and herein or for device class M, the requirements of MIL-PRF-38535, appendix A and herein.

3.7 Certificate of conformance. A certificate of conformance as required for device classes Q and V in MIL-PRF-38535 or for device class M in MIL-PRF-38535, appendix A shall be provided with each lot of microcircuits delivered to this drawing.

3.8 Notification of change for device class M. For device class M, notification to DESC-EC of change of product (see 6.2 herein) involving devices acquired to this drawing is required for any change as defined in MIL-STD-973.

3.9 Verification and review for device class M. For device class M, DESC, DESC's agent, and the acquiring activity retain the option to review the manufacturer's facility and applicable required documentation. Offshore documentation shall be made available onshore at the option of the reviewer.

3.10 Microcircuit group assignment for device class M. Device class M devices covered by this drawing shall be in microcircuit group number 36 (see MIL-PRF-38535, appendix A).

STANDARD MICROCIRCUIT DRAWING DEFENSE ELECTRONICS SUPPLY CENTER DAYTON, OHIO 45444	SIZE A		5962-96596
		REVISION LEVEL	SHEET 4

4. QUALITY ASSURANCE PROVISIONS

4.1 Sampling and inspection. For device classes Q and V, sampling and inspection procedures shall be in accordance with MIL-PRF-38535 or as modified in the device manufacturer's Quality Management (QM) plan. The modification in the QM plan shall not affect the form, fit, or function as described herein. For device class M, sampling and inspection procedures shall be in accordance with MIL-PRF-38535, appendix A.

4.2 Screening. For device classes Q and V, screening shall be in accordance with MIL-PRF-38535, and shall be conducted on all devices prior to qualification and technology conformance inspection. For device class M, screening shall be in accordance with method 5004 of MIL-STD-883, and shall be conducted on all devices prior to quality conformance inspection.

4.2.1 Additional criteria for device class M.

a. Burn-in test, method 1015 of MIL-STD-883.

(1) Test condition A, B, C, or D. The test circuit shall be maintained by the manufacturer under document revision level control and shall be made available to the preparing or acquiring activity upon request. The test circuit shall specify the inputs, outputs, biases, and power dissipation, as applicable, in accordance with the intent specified in test method 1015.

(2)  $T_A = +125^\circ\text{C}$ , minimum.

b. Interim and final electrical test parameters shall be as specified in table IIA herein.

4.2.2 Additional criteria for device classes Q and V.

a. The burn-in test duration, test condition and test temperature, or approved alternatives shall be as specified in the device manufacturer's QM plan in accordance with MIL-PRF-38535. The burn-in test circuit shall be maintained under document revision level control of the device manufacturer's Technology Review Board (TRB) in accordance with MIL-PRF-38535 and shall be made available to the acquiring or preparing activity upon request. The test circuit shall specify the inputs, outputs, biases, and power dissipation, as applicable, in accordance with the intent specified in test method 1015 of MIL-STD-883.

b. Interim and final electrical test parameters shall be as specified in table IIA herein.

c. Additional screening for device class V beyond the requirements of device class Q shall be as specified in MIL-PRF-38535, appendix B or as modified in the device manufacturer's Quality Management (QM) plan.

4.3 Qualification inspection for device classes Q and V. Qualification inspection for device classes Q and V shall be in accordance with MIL-PRF-38535. Inspections to be performed shall be those specified in MIL-PRF-38535 and herein for groups A, B, C, D, and E inspections (see 4.4.1 through 4.4.4).

4.3.1 Electrostatic discharge sensitivity (ESDS) qualification inspection. ESDS testing shall be performed in accordance with MIL-STD-883, method 3015. ESDS testing shall be measured only for initial qualification and after process or design changes which may affect ESDS classification.

4.4 Conformance inspection. Technology conformance inspection for classes Q and V shall be in accordance with MIL-PRF-38535 or as specified in QM plan including groups A, B, C, D, and E inspections and as specified herein except where option 2 of MIL-PRF-38535 permits alternate in-line control testing. Quality conformance inspection for device class M shall be in accordance with MIL-PRF-38535, appendix A and as specified herein. Inspections to be performed for device class M shall be those specified in method 5005 of MIL-STD-883 and herein for groups A, B, C, D, and E inspections (see 4.4.1 through 4.4.4).

4.4.1 Group A inspection.

a. Tests shall be as specified in table IIA herein.

b. For device class M, subgroups 7 and 8 tests shall be sufficient to verify the truth table in figure 2 herein. For device classes Q and V, subgroups 7 and 8 shall include verifying the functionality of the device.

c.  $C_{IN}$  and  $C_{OUT}$  shall be measured only for initial qualification and after process or design changes which may affect capacitance.  $C_{IN}$  shall be measured between the designated terminal and  $V_{SS}$  at a frequency of 1 MHz. For  $C_{IN}$  and  $C_{OUT}$ , test all applicable pins on five devices with zero failures.

4.4.2 Group C inspection. The group C inspection end-point electrical parameters shall be as specified in table IIA herein.

STANDARD MICROCIRCUIT DRAWING DEFENSE ELECTRONICS SUPPLY CENTER DAYTON, OHIO 45444	SIZE A		5962-96596
		REVISION LEVEL	SHEET 5

TABLE IA. Electrical performance characteristics.

Test Symbol	Symbol	Test conditions 1/ -55°C ≤ T <sub>C</sub> ≤ +125°C unless otherwise specified	Device type	V <sub>DD</sub>	Group A subgroups	Limits 2/		Unit
						Min	Max	
High level output voltage	V <sub>OH</sub>	For all inputs affecting output under test, V <sub>IN</sub> = V <sub>DD</sub> or V <sub>SS</sub> I <sub>OH</sub> = -100 μA	All	4.5 V	1, 2, 3	4.25		V
			M, D, L, R, F, G, H 3/		All	1	4.25	
Low level output voltage	V <sub>OL</sub>	For all inputs affecting output under test, V <sub>IN</sub> = V <sub>DD</sub> or V <sub>SS</sub> I <sub>OL</sub> = 100 μA	All	4.5 V	1, 2, 3		0.25	V
			M, D, L, R, F, G, H 3/		All	1	0.25	
High level input voltage	V <sub>IH</sub>		All	4.5 V	1, 2, 3	3.15		V
			M, D, L, R, F, G, H 3/		All	1	3.15	
			All	5.5 V	1, 2, 3	3.85		
			M, D, L, R, F, G, H 3/		All	1	3.85	
Low level input voltage	V <sub>IL</sub>		All	4.5 V	1, 2, 3		1.35	V
			M, D, L, R, F, G, H 3/		All	1	1.35	
			All	5.5 V	1, 2, 3		1.65	
			M, D, L, R, F, G, H 3/		All	1	1.65	
Input current high	I <sub>IH</sub>	For input under test, V <sub>IN</sub> = 5.5 V For all other inputs, V <sub>IN</sub> = V <sub>DD</sub> or V <sub>SS</sub>	All	5.5 V	1, 2, 3		+1.0	μA
			M, D, L, R, F, G, H 3/		All	1	+1.0	
Input current low	I <sub>IL</sub>	For input under test, V <sub>IN</sub> = V <sub>SS</sub> For all other inputs, V <sub>IN</sub> = V <sub>DD</sub> or V <sub>SS</sub>	All	5.5 V	1, 2, 3		-1.0	μA
			M, D, L, R, F, G, H 3/		All	1	-1.0	
Quiescent supply current	I <sub>DDQ</sub>	V <sub>IN</sub> = V <sub>DD</sub> or V <sub>SS</sub>	All	5.5 V	1, 2, 3		10.0	μA
			M, D, L, R, F, G, H 3/		All	1	10.0	
Short circuit output current	I <sub>QS</sub> 4/ 5/	V <sub>OUT</sub> = V <sub>DD</sub> and V <sub>SS</sub>	All	5.5 V	1, 2, 3		±200	mA
Input capacitance	C <sub>IN</sub>	f = 1 MHz, see 4.4.1c	All	0.0 V	4		15	pF
Output capacitance	C <sub>OUT</sub>	f = 1 MHz, see 4.4.1c	All	0.0 V	4		15	pF
Power dissipation	P <sub>SW</sub> 6/	C <sub>L</sub> = 50 pF, per switching output	All	4.5 V and 5.5 V	4, 5, 6		1.9	mW/MHz

See footnotes at end of table.

STANDARD MICROCIRCUIT DRAWING DEFENSE ELECTRONICS SUPPLY CENTER DAYTON, OHIO 45444	SIZE A		5962-96596
		REVISION LEVEL	SHEET 6

DESC FORM 193A  
JUL 94

9004708 0021522 470

TABLE IA. Electrical performance characteristics - Continued.

Test symbol	Test conditions 1/ -55°C ≤ T <sub>C</sub> ≤ +125°C unless otherwise specified	Device type	V <sub>DD</sub>	Group A subgroups	Limits 2/		Unit	
					Min	Max		
Functional test	V <sub>IH</sub> = 0.7 V <sub>DD</sub> , V <sub>IL</sub> = 0.3 V <sub>DD</sub> See 4.4.1b	All	4.5 V and 5.5 V	7, 8	L	H		
		M, D, L, R, F, G, H 3/	All	7	L	H		
Propagation delay time, any input to output	t <sub>PLH</sub> 8/	C <sub>L</sub> = 50 pF, see figure 4	All	4.5 V and 5.5 V	9, 10, 11	2.0	14.0	ns
			M, D, L, R, F, G, H 3/	All	9	2.0	14.0	
	t <sub>PHL</sub> 8/	C <sub>L</sub> = 50 pF, see figure 4	All	4.5 V and 5.5 V	9, 10, 11	1.0	12.0	
			M, D, L, R, F, G, H 3/	All	9	1.0	12.0	

- 1/ Each input/output, as applicable, shall be tested at the specified temperature, for the specified limits, to the tests in table IA herein. Output terminals not designated shall be high level logic, low level logic, or open, except for the I<sub>DDQ</sub> test, the output terminals shall be open. When performing the I<sub>DDQ</sub> test, the current meter shall be placed in the circuit such that all current flows through the meter.
- 2/ For negative and positive voltage and current values, the sign designates the potential difference in reference to V<sub>SS</sub> and the direction of current flow respectively; and the absolute value of the magnitude, not the sign, is relative to the minimum and maximum limits, as applicable, listed herein.
- 3/ Devices supplied to this drawing meet all levels M, D, L, R, F, G, and H of irradiation. However, these devices are only tested at the "H" level. Pre and post irradiation values are identical unless otherwise specified in table IA. When performing post irradiation electrical measurements for any RHA level, T<sub>A</sub> = +25°C.
- 4/ This parameter is supplied as design limit but not guaranteed or tested.
- 5/ No more than one output should be shorted at a time for a maximum duration of one second.
- 6/ This value is calculated during the design/qualification process and is supplied as a design limit but is not tested. Total power consumption is determined by both idle/standby power consumption (P<sub>s</sub>) and "at frequency" power consumption (P<sub>f</sub>). To determine standby power consumption use the formula:  

$$P_T = (n \times P_{SW} \times f) + (Loads \times Prdy \times I_{OL} \times V_{OL})$$
 where n is the number of switching outputs; f is the frequency of the device; loads is the resistive power component, typically a TTL load; and Prdy is the percent duty cycle that the output is sinking current.
- 7/ The test vectors used to verify the truth table shall, at a minimum, test all functions of each input and output. All possible input to output logic patterns per function shall be guaranteed, if not tested, to the truth table in figure 2 herein. For V<sub>OJT</sub> measurements, L ≤ 0.5 V and H ≥ 4.0 V and are tested at V<sub>SS</sub> = 4.5 V and V<sub>SS</sub> = 5.5 V.
- 8/ For propagation delay tests, all paths must be tested.

TABLE IB. SEP test limits. 1/ 2/

Device type	T <sub>A</sub> = Temperature ±10°C 3/	V <sub>DD</sub> = 4.5 V		Bias for latch-up test V <sub>DD</sub> = 5.5 V no latch-up LET = 3/
		Effective LET no upsets [MeV/(mg/cm <sup>2</sup> )]	Maximum device cross section	
01	+25°C	LET ≥ 80	6 x 10 <sup>-9</sup> cm <sup>2</sup> /bit	≥ 80

- 1/ For SEP test conditions, see 4.4.4 herein.
- 2/ Technology characterization and model verification supplemented by in-line data may be used in lieu of end-of-line testing. Test plan must be approved by TRB and qualifying activity.
- 3/ Worst case temperature is T<sub>A</sub> ≥ +125 °C.

STANDARD MICROCIRCUIT DRAWING DEFENSE ELECTRONICS SUPPLY CENTER DAYTON, OHIO 45444	SIZE <b>A</b>		5962-96596
		REVISION LEVEL	SHEET 7

查询"5962H9659601QCA"供应商

Device type	All
Case outlines	C and X
Terminal number	Terminal symbol
1	Y1
2	A1
3	B1
4	C1
5	D1
6	NC
7	V <sub>SS</sub>
8	NC
9	A2
10	B2
11	C2
12	D2
13	Y2
14	V <sub>DD</sub>

NC = No connection

FIGURE 1. Terminal connections.

Inputs				Outputs
An	Bn	Cn	Dn	Yn
L	L	L	L	H
H	X	X	X	L
X	H	X	X	L
X	X	H	X	L
X	X	X	H	L

H = High voltage level  
 L = Low voltage level  
 X = Don't care, either a H or L

FIGURE 2. Truth table.

<b>STANDARD          MICROCIRCUIT DRAWING          DEFENSE ELECTRONICS SUPPLY CENTER          DAYTON, OHIO 45444</b>	<b>SIZE          A</b>		<b>5962-96596</b>
		REVISION LEVEL	SHEET <b>8</b>

DESC FORM 193A  
 JUL 94

9004708 0021524 243



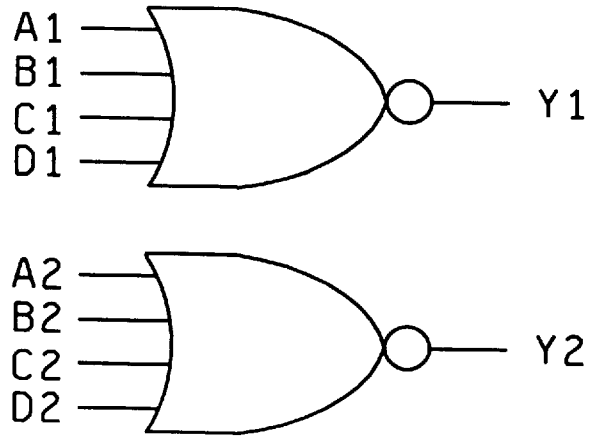
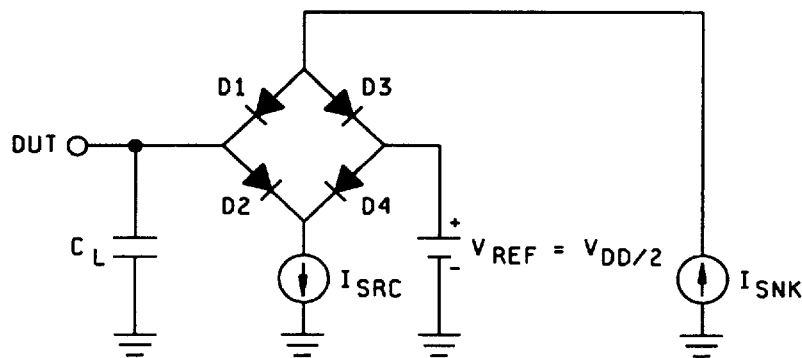
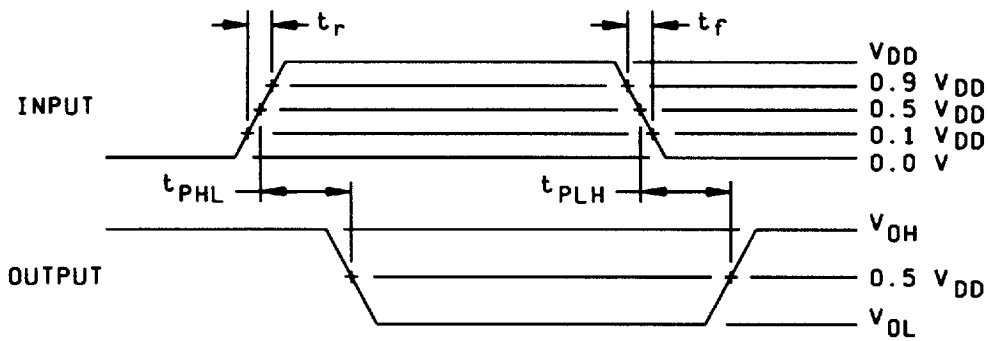

FIGURE 3. Logic diagram.

STANDARD MICROCIRCUIT DRAWING DEFENSE ELECTRONICS SUPPLY CENTER DAYTON, OHIO 45444	SIZE <b>A</b>		5962-96596
		REVISION LEVEL	SHEET <b>9</b>

DESC FORM 193A  
JUL 94

■ 9004708 0021525 1&T ■



NOTES:

- 1/  $C_L = 50$  pF minimum or equivalent (includes test jig and probe capacitance).
- 2/  $I_{SRC}$  is set to  $-1$  mA and  $I_{SNK}$  is set to  $1$  mA for  $t_{PHL}$  and  $t_{PLH}$  measurements.
- 3/ Input signal from pulse generator:  $V_{IN} = 0.0 V$  to  $V_{DD}$ ;  $f \leq 10$  MHz;  $t_r = 1.0$  V/ns  $\pm 0.3$  ns/V;  $t_f = 1.0$  V/ns  $\pm 0.3$  ns/V;  $t_r$  and  $t_f$  shall be measured from  $0.1 V_{DD}$  to  $0.9 V_{DD}$  and from  $0.9 V_{DD}$  to  $0.1 V_{DD}$ , respectively.

FIGURE 4. Switching waveforms and test circuit.

STANDARD MICROCIRCUIT DRAWING DEFENSE ELECTRONICS SUPPLY CENTER DAYTON, OHIO 45444	SIZE <b>A</b>		5962-96596
		REVISION LEVEL	SHEET 10

TABLE IIA. Electrical test requirements.

Test Requirements	Subgroups (in accordance with MIL-STD-883, method 5005, table I)	Subgroups (in accordance with MIL-PRF-38535, table III)	
	Device class M	Device class Q	Device class V
Interim electrical parameters (see 4.2)	1, 7, 9	1, 7, 9	1, 7, 9
Final electrical parameters (see 4.2)	1, 2, 3, 7, 8, 9, 10, 11 1/	1, 2, 3, 7, 8, 9, 10, 11 1/	1, 2, 3, 7, 8, 9, 10, 11 2/ 3/
Group A test requirements (see 4.4)	1, 2, 3, 4, 5, 6, 7, 8, 9, 10, 11	1, 2, 3, 4, 5, 6, 7, 8, 9, 10, 11	1, 2, 3, 4, 5, 6, 7, 8, 9, 10, 11
Group C end-point electrical parameters (see 4.4)	1, 2, 3, 7, 8, 9, 10, 11	1, 2, 3, 7, 8, 9, 10, 11	1, 2, 3, 7, 8, 9, 10, 11 3/
Group D end-point electrical parameters (see 4.4)	1, 7, 9	1, 7, 9	1, 7, 9
Group E end-point electrical parameters (see 4.4)	1, 7, 9	1, 7, 9	1, 7, 9

- 1/ PDA applies to subgroup 1 and 7.
- 2/ PDA applies to subgroups 1, 7, and delta's.
- 3/ Delta limits as specified in Table IIB herein shall be required where specified, and the delta values shall be completed with reference to the zero hour electrical parameters.

TABLE IIB. Burn-in and operating life test. Delta parameters (+25°C).

Parameters	Symbol	Delta limits
Output voltage low	V <sub>OL</sub>	±100 mV
Output voltage high	V <sub>OH</sub>	±100 mV

TABLE III. Irradiation test connections.

Device type	Open	Ground	V <sub>DD</sub> = 5.0 V ±0.5 V
01	1, 6, 8, 13	2, 3, 4, 5, 7, 9, 10, 11, 12	14

NOTE: Each pin except 7 and 14 will have a resistor of 2.49 kΩ ±5% for irradiation testing.

4.4.2.1 Additional criteria for device class M. Steady-state life test conditions, method 1005 of MIL-STD-883:

- a. Test condition A, B, C, or D. The test circuit shall be maintained by the manufacturer under document revision level control and shall be made available to the preparing or acquiring activity upon request. The test circuit shall specify the inputs, outputs, biases, and power dissipation, as applicable, in accordance with the intent specified in test method 1005 of MIL-STD-883.
- b. T<sub>A</sub> = +125°C, minimum.
- c. Test duration: 1,000 hours, except as permitted by method 1005 of MIL-STD-883.

STANDARD MICROCIRCUIT DRAWING DEFENSE ELECTRONICS SUPPLY CENTER DAYTON, OHIO 45444	SIZE <b>A</b>		5962-96596
		REVISION LEVEL	SHEET 11

DESC FORM 193A  
JUL 94

9004708 0021527 T52

4.4.2.2 Additional criteria for device classes Q and V. The steady-state life test duration, test condition and test temperature, or approved alternatives shall be as specified in the device manufacturer's QM plan in accordance with MIL-PRF-38535. The test circuit shall be maintained under document revision level control by the device manufacturer's TRB in accordance with MIL-PRF-38535 and shall be made available to the acquiring or preparing activity upon request. The test circuit shall specify the inputs, outputs, biases, and power dissipation, as applicable, in accordance with the intent specified in test method 1005 of MIL-STD-883.

4.4.3 Group D inspection. The group D inspection end-point electrical parameters shall be as specified in table IIA herein.

4.4.4 Group E inspection. Group E inspection is required only for parts intended to be marked as radiation hardness assured (see 3.5 herein). RHA levels for device classes M, Q, and V shall be as specified in MIL-PRF-38535. End-point electrical parameters shall be as specified in table IIA herein.

4.4.4.1 Total dose irradiation testing. Total dose irradiation testing shall be performed in accordance with MIL-STD-883, test method 1019 and as specified herein.

4.4.4.1.1 Accelerated aging testing. Accelerated aging testing shall be performed on all devices requiring a RHA level greater than 5k rads (Si). The post-anneal end-point electrical parameter limits shall be as specified in table IA herein and shall be the pre-irradiation end-point electrical parameter limits at 25°C ±5°C. Testing shall be performed at initial qualification and after any design or process changes which may affect the RHA response of the device.

4.4.4.2 Dose rate induced latchup testing. Dose rate induced latchup testing shall be performed in accordance with test method 1010 of MIL-STD-883 and as specified herein (see 1.4 herein). Tests shall be performed on devices, SEC, or approved test structures at technology qualification and after any design or process changes which may affect the RHA capability of the process.

4.4.4.3 Dose rate upset testing. Dose rate upset testing shall be performed in accordance with test method 1011 of MIL-STD-883 and herein (see 1.4 herein).

- a. Transient dose rate upset testing shall be performed at initial qualification and after any design or process changes which may affect the RHA performance of the devices. Test 10 devices with 0 defects unless otherwise specified.
- b. Transient dose rate upset testing for class Q and V devices shall be performed as specified by a TRB approved radiation hardness assurance plan and MIL-PRF-38535.

4.4.4.4 Single event phenomena (SEP). SEP testing shall be required on class V devices (see 1.4 herein). SEP testing shall be performed on a technology process on the Standard Evaluation Circuit (SEC) or alternate SEP test vehicle as approved by the qualifying activity at initial qualification and after any design or process changes which may affect the upset or latchup characteristics. The recommended test conditions for SEP are as follows:

- a. The ion beam angle of incidence shall be between normal to the die surface and 60° to the normal, inclusive (i.e. 0° ≤ angle ≤ 60°). No shadowing of the ion beam due to fixturing or package related effects is allowed.
- b. The fluence shall be ≥ 100 errors or ≥ 10<sup>6</sup> ions/cm<sup>2</sup>.
- c. The flux shall be between 10<sup>2</sup> and 10<sup>5</sup> ions/cm<sup>2</sup>/s. The cross-section shall be verified to be flux independent by measuring the cross-section at two flux rates which differ by at least an order of magnitude.
- d. The particle range shall be ≥ 20 micron in silicon.
- e. The test temperature shall be +25°C for the upset measurements and the maximum rated operating temperature ±10°C for the latchup measurements.
- f. Bias conditions shall be defined by the manufacturer for the latchup measurements.
- g. Test four devices with zero failures.
- h. For SEP test limits, see table IB herein.

4.5 Methods of inspection. Methods of inspection shall be specified as follows:

4.5.1 Voltage and current. Unless otherwise specified, all voltages given are referenced to the microcircuit V<sub>SS</sub> terminal. Currents given are conventional current and positive when flowing into the referenced terminal.

<b>STANDARD MICROCIRCUIT DRAWING DEFENSE ELECTRONICS SUPPLY CENTER DAYTON, OHIO 45444</b>	<b>SIZE A</b>		<b>5962-96596</b>
		<b>REVISION LEVEL</b>	<b>SHEET 12</b>

DESC FORM 193A  
JUL 94

■ 9004708 0021528 999 ■

5. PACKAGING

5.1 Packaging requirements. The requirements for packaging shall be in accordance with MIL-PRF-38535 for device classes Q and V or MIL-PRF-38535 appendix A for device class M.

6. NOTES

6.1 Intended use. Microcircuits conforming to this drawing are intended for use for Government microcircuit applications (original equipment), design applications, and logistics purposes.

6.1.1 Replaceability. Microcircuits covered by this drawing will replace the same generic device covered by a contractor-prepared specification or drawing.

6.1.2 Substitutability. Device class Q devices will replace device class M devices.

6.2 Configuration control of SMD's. All proposed changes to existing SMD's will be coordinated with the users of record for the individual documents. This coordination will be accomplished in accordance with MIL-STD-973 using DD Form 1692, Engineering Change Proposal.

6.3 Record of users. Military and industrial users should inform Defense Electronics Supply Center when a system application requires configuration control and which SMD's are applicable to that system. DESC will maintain a record of users and this list will be used for coordination and distribution of changes to the drawings. Users of drawings covering microelectronic devices (FSC 5962) should contact DESC-EC, telephone (513) 296-6047.

6.4 Comments. Comments on this drawing should be directed to DESC-EC, Dayton, Ohio 45444-5270, or telephone (513) 296-8525.

6.5 Abbreviations, symbols, and definitions. The abbreviations, symbols, and definitions used herein are defined in MIL-PRF-38535 and MIL-HDBK-1331.

6.6 Sources of supply.

6.6.1 Sources of supply for device classes Q and V. Sources of supply for device classes Q and V are listed in QML-38535. The vendors listed in QML-38535 have submitted a certificate of compliance (see 3.6 herein) to DESC-EC and have agreed to this drawing.

6.6.2 Approved sources of supply for device class M. Approved sources of supply for class M are listed in MIL-HDBK-103. The vendors listed in MIL-HDBK-103 have agreed to this drawing and a certificate of compliance (see 3.6 herein) has been submitted to and accepted by DESC-EC.

6.7 Additional information. A copy of the following additional data shall be maintained and available from the device manufacturer:

- a. RHA upset levels.
- b. Test conditions (SEP).
- c. Number of upsets (SEP).
- d. Number of transients (SEP).
- e. Occurrence of latchup (SEP).

<b>STANDARD MICROCIRCUIT DRAWING DEFENSE ELECTRONICS SUPPLY CENTER DAYTON, OHIO 45444</b>	<b>SIZE A</b>		<b>5962-96596</b>
		<b>REVISION LEVEL</b>	<b>SHEET 13</b>

DESC FORM 193A  
JUL 94

■ 9004708 0021529 825 ■