

REVISIONS

LTR	DESCRIPTION	DATE (YR-MO-DA)	APPROVED
	查询5962R9667901VLC*供应商		

REV																				
SHEET																				
REV																				
SHEET	15	16	17	18																
REV STATUS OF SHEETS				REV																
				SHEET	1	2	3	4	5	6	7	8	9	10	11	12	13	14		
PMIC N/A				PREPARED BY Larry T. Gauder				DEFENSE ELECTRONICS SUPPLY CENTER DAYTON, OHIO 45444												
STANDARD MICROCIRCUIT DRAWING THIS DRAWING IS AVAILABLE FOR USE BY ALL DEPARTMENTS AND AGENCIES OF THE DEPARTMENT OF DEFENSE AMSC N/A				CHECKED BY Monica L. Poelking				MICROCIRCUIT, DIGITAL, RADIATION HARDENED CMOS, ANALOG MULTIPLEXERS/DEMULTIPLEXERS, MONOLITHIC SILICON												
				APPROVED BY Monica L. Poelking																
				DRAWING APPROVAL DATE 96-01-04				SIZE A	CAGE CODE 67268	5962-96679										
				REVISION LEVEL				SHEET	1	OF	18									

DESC FORM 193
JUL 94

DISTRIBUTION STATEMENT A. Approved for public release; distribution is unlimited.

5962-E210-96

■ 9004708 0018364 5T0 ■

1. SCOPE

1.1 Scope. This drawing forms a part of a one part - one part number documentation system (see 6.6 herein). Two product assurance classes consisting of military high reliability (device classes Q and M) and space application (device class V), and a choice of case outlines and lead finishes are available and are reflected in the Part or Identifying Number (PIN). Device class M microcircuits represent non-JAN class B microcircuits in accordance with 1.2.1 of MIL-STD-883, "Provisions for the use of MIL-STD-883 in conjunction with compliant non-JAN devices". When available, a choice of Radiation Hardness Assurance (RHA) levels are reflected in the PIN.

1.2 PIN. The PIN shall be as shown in the following example:

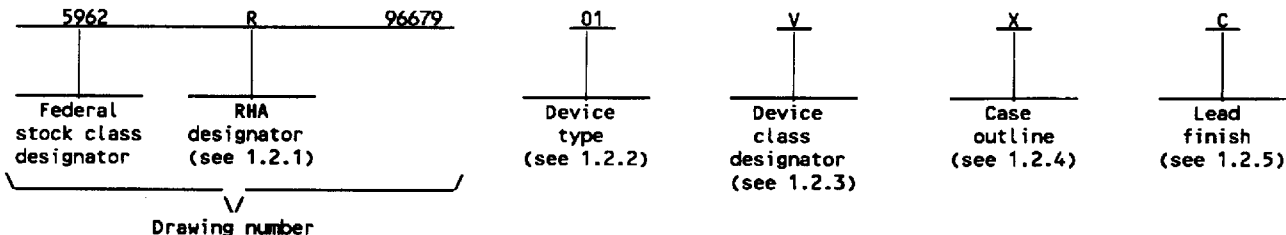

1.2.1 RHA designator. Device class M RHA marked devices shall meet the MIL-I-38535 appendix A specified RHA levels and shall be marked with the appropriate RHA designator. Device classes Q and V RHA marked devices shall meet the MIL-I-38535 specified RHA levels and shall be marked with the appropriate RHA designator. A dash (-) indicates a non-RHA device.

1.2.2 Device type(s). The device type(s) shall identify the circuit function as follows:

<u>Device type</u>	<u>Generic number</u>	<u>Circuit function</u>
01	4067B	Radiation hardened CMOS analog single 16 channel multiplexers/demultiplexers
02	4097B	Radiation hardened CMOS analog differential 8 channel multiplexers/demultiplexers

1.2.3 Device class designator. The device class designator shall be a single letter identifying the product assurance level as follows:

<u>Device class</u>	<u>Device requirements documentation</u>
M	Vendor self-certification to the requirements for non-JAN class B microcircuits in accordance with 1.2.1 of MIL-STD-883
Q or V	Certification and qualification to MIL-I-38535

1.2.4 Case outline(s). The case outline(s) shall be as designated in MIL-STD-1835 and as follows:

<u>Outline letter</u>	<u>Descriptive designator</u>	<u>Terminals</u>	<u>Package style</u>
L	CDIP4-T24	24	dual-in-line package
X	CDFP4-F24	24	flat package

1.2.5 Lead finish. The lead finish shall be as specified in MIL-STD-883 (see 3.1 herein) for class M or MIL-I-38535 for classes Q and V. Finish letter "X" shall not be marked on the microcircuit or its packaging. The "X" designation is for use in specifications when lead finishes A, B, and C are considered acceptable and interchangeable without preference.

STANDARD MICROCIRCUIT DRAWING DEFENSE ELECTRONICS SUPPLY CENTER DAYTON, OHIO 45444	SIZE A		5962-96679
		REVISION LEVEL	SHEET 2

1.3 Absolute maximum ratings. 1/ 2/ 3/

查询"5962R9667901VLC"供应商

Supply voltage range (V_{DD})	-0.5 V dc to +20 V dc
Input voltage range	-0.5 V dc to $V_{DD} + 0.5$ Vdc
DC input current, any one input	±10 mA
Device dissipation per output transistor	100 mW
Storage temperature range (T_{STG})	-65°C to +150°C
Lead temperature (soldering, 10 seconds)	+265°C
Thermal resistance, junction-to-case (θ_{JC}):	
Case L	25°C/W
Case X	24°C/W
Thermal resistance, junction-to-ambient (θ_{JA}):	
Case L	65°C/W
Case X	89°C/W
Junction temperature (T_J)	+175°C
Maximum power dissipation at $T_A = +125^\circ\text{C}$ (P_D): 4/	
Case L	0.77 W
Case X	0.56 W

1.4 Recommended operating conditions.

Supply voltage range (V_{DD})	3.0 V dc to +18 V dc
Case operating temperature range (T_C)	-55°C to +125°C
Input voltage (V_{IN})	0 V to V_{DD}
Output voltage (V_{OUT})	0 V to V_{DD}
Radiation features:	
Total dose	1 x 10 ⁵ Rads (Si)
Single event phenomenon (SEP) effective linear energy threshold, no upsets or latchup (see 4.4.4.4)	>75 MEV/(cm ² /mg) 5/
Dose rate upset (20 ns pulse)	> 5 x 10 ⁸ Rads(Si)/s 5/
Dose rate latch-up	> 2 x 10 ⁸ Rads(Si)/s 5/
Dose rate survivability	> 5 x 10 ¹¹ Rads(Si)/s 5/

2. APPLICABLE DOCUMENTS

2.1 Government specification, standards, bulletin, and handbook. Unless otherwise specified, the following specification, standards, bulletin, and handbook of the issue listed in that issue of the Department of Defense Index of Specifications and Standards specified in the solicitation, form a part of this drawing to the extent specified herein.

SPECIFICATION

MILITARY

MIL-I-38535 - Integrated Circuits, Manufacturing, General Specification for.

STANDARDS

MILITARY

MIL-STD-883 - Test Methods and Procedures for Microelectronics.
MIL-STD-973 - Configuration Management.
MIL-STD-1835 - Microcircuit Case Outlines.

- 1/ Stresses above the absolute maximum rating may cause permanent damage to the device. Extended operation at the maximum levels may degrade performance and affect reliability.
- 2/ Unless otherwise specified, all voltages are referenced to V_{SS} .
- 3/ The limits for the parameters specified herein shall apply over the full specified V_{CC} range and case temperature range of -55°C to +125°C unless otherwise noted.
- 4/ If device power exceeds package dissipation capability, provide heat sinking or derate linearly (the derating is based on θ_{JA}) at the following rate:

Case L	15.4 mW/°C
Case X	11.2 mW/°C
- 5/ Guaranteed by design or process but not tested.

STANDARD MICROCIRCUIT DRAWING DEFENSE ELECTRONICS SUPPLY CENTER DAYTON, OHIO 45444	SIZE A		5962-96679
		REVISION LEVEL	SHEET 3

DESC FORM 193A
JUL 94

9004708 0018366 373

BULLETIN

MILITARY
查询 5962R9667901VLC"供应商

MIL-BUL-103 - List of Standardized Military Drawings (SMD's).

HANDBOOK

MILITARY

MIL-HDBK-780 - Standardized Military Drawings.

(Copies of the specification, standards, bulletin, and handbook required by manufacturers in connection with specific acquisition functions should be obtained from the contracting activity or as directed by the contracting activity.)

2.2 Order of precedence. In the event of a conflict between the text of this drawing and the references cited herein, the text of this drawing shall take precedence.

3. REQUIREMENTS

3.1 Item requirements. The individual item requirements for device class M shall be in accordance with 1.2.1 of MIL-STD-883, "Provisions for the use of MIL-STD-883 in conjunction with compliant non-JAN devices" and as specified herein. The individual item requirements for device classes Q and V shall be in accordance with MIL-I-38535 and as specified herein or as modified in the device manufacturer's Quality Management (QM) plan. The modification in the QM plan shall not affect the form, fit, or function as described herein.

3.2 Design, construction, and physical dimensions. The design, construction, and physical dimensions shall be as specified in MIL-STD-883 (see 3.1 herein) for device class M and MIL-I-38535 for device classes Q and V herein.

3.2.1 Case outlines. The case outlines shall be in accordance with 1.2.4 herein.

3.2.2 Terminal connections. The terminal connections shall be as specified on figure 1.

3.2.3 Truth table. The truth table shall be as specified on figure 2.

3.2.4 Block diagrams. The block diagrams shall be as specified on figure 3.

3.2.5 Radiation test connections. The radiation test connections shall be as specified in table III herein.

3.3 Electrical performance characteristics and postirradiation parameter limits. Unless otherwise specified herein, the electrical performance characteristics and postirradiation parameter limits are as specified in table I and shall apply over the full case operating temperature range.

3.4 Electrical test requirements. The electrical test requirements shall be the subgroups specified in table IIA. The electrical tests for each subgroup are defined in table I.

3.5 Marking. The part shall be marked with the PIN listed in 1.2 herein. Marking for device class M shall be in accordance with MIL-STD-883 (see 3.1 herein). In addition, the manufacturer's PIN may also be marked as listed in MIL-BUL-103. Marking for device classes Q and V shall be in accordance with MIL-I-38535.

3.5.1 Certification/compliance mark. The compliance mark for device class M shall be a "C" as required in MIL-STD-883 (see 3.1 herein). The certification mark for device classes Q and V shall be a "QML" or "Q" as required in MIL-I-38535.

3.6 Certificate of compliance. For device class M, a certificate of compliance shall be required from a manufacturer in order to be listed as an approved source of supply in MIL-BUL-103 (see 6.7.2 herein). For device classes Q and V, a certificate of compliance shall be required from a QML-38535 listed manufacturer in order to supply to the requirements of this drawing (see 6.7.1 herein). The certificate of compliance submitted to DESC-EC prior to listing as an approved source of supply for this drawing shall affirm that the manufacturer's product meets, for device class M, the requirements of MIL-STD-883 (see 3.1 herein), or for device classes Q and V, the requirements of MIL-I-38535 and the requirements herein.

3.7 Certificate of conformance. A certificate of conformance as required for device class M in MIL-STD-883 (see 3.1 herein) or for device classes Q and V in MIL-I-38535 shall be provided with each lot of microcircuits delivered to this drawing.

STANDARD MICROCIRCUIT DRAWING DEFENSE ELECTRONICS SUPPLY CENTER DAYTON, OHIO 45444	SIZE A		5962-96679
		REVISION LEVEL	SHEET 4

DESC FORM 193A
JUL 94

9004708 0018367 20T

3.8 Notification of change for device class M. For device class M, notification to DESC-EC of change of product (see 6.2 herein) involving devices acquired to this drawing is required for any change as defined in MIL-STD-973.

查询"5962R9667901VLC"供应商

3.9 Verification and review for device class M. For device class M, DESC, DESC's agent, and the acquiring activity retain the option to review the manufacturer's facility and applicable required documentation. Offshore documentation shall be made available onshore at the option of the reviewer.

3.10 Microcircuit group assignment for device class M. Device class M devices covered by this drawing shall be in microcircuit group number 39 (see MIL-I-38535, appendix A).

4. QUALITY ASSURANCE PROVISIONS

4.1 Sampling and inspection. For device class M, sampling and inspection procedures shall be in accordance with MIL-STD-883 (see 3.1 herein). For device classes Q and V, sampling and inspection procedures shall be in accordance with MIL-I-38535 or as modified in the device manufacturer's quality management (QM) plan. The modification in the QM plan shall not affect form, fit, or function as described herein.

4.2 Screening. For device class M, screening shall be in accordance with method 5004 of MIL-STD-883, and shall be conducted on all devices prior to quality conformance inspection. For device classes Q and V, screening shall be in accordance with MIL-I-38535, and shall be conducted on all devices prior to qualification and technology conformance inspection.

4.2.1 Additional criteria for device class M.

a. Burn-in test, method 1015 of MIL-STD-883.

(1) Test condition A, B, C, or D. The test circuit shall be maintained by the manufacturer under document revision level control and shall be made available to the preparing or acquiring activity upon request. The test circuit shall specify the inputs, outputs, biases, and power dissipation, as applicable, in accordance with the intent specified in test method 1015.

(2) $T_A = +125^\circ\text{C}$, minimum.

b. Interim and final electrical test parameters shall be as specified in table IIA herein.

4.2.2 Additional criteria for device classes Q and V.

a. The burn-in test duration, test condition and test temperature, or approved alternatives shall be as specified in the device manufacturer's QM plan in accordance with MIL-I-38535. The burn-in test circuit shall be maintained under document revision level control of the device manufacturer's Technology Review Board (TRB) in accordance with MIL-I-38535 and shall be made available to the acquiring or preparing activity upon request. The test circuit shall specify the inputs, outputs, biases, and power dissipation, as applicable, in accordance with the intent specified in test method 1015.

b. Interim and final electrical test parameters shall be as specified in table IIA herein.

c. Additional screening for device class V beyond the requirements of device class Q shall be as specified in appendix B of MIL-I-38535 or as modified in the device manufacturer's quality management (QM) plan.

4.3 Qualification inspection for device classes Q and V. Qualification inspection for device classes Q and V shall be in accordance with MIL-I-38535. Inspections to be performed shall be those specified in MIL-I-38535 and herein for groups A, B, C, D, and E inspections (see 4.4.1 through 4.4.4).

4.3.1 Electrostatic discharge sensitivity (ESDS) qualification inspection. ESDS testing shall be performed in accordance with MIL-STD-883, method 3015. ESDS testing shall be measured only for initial qualification and after process or design changes which may affect ESDS classification.

4.4 Conformance inspection. Quality conformance inspection for device class M shall be in accordance with MIL-STD-883 (see 3.1 herein) and as specified herein. Inspections to be performed for device class M shall be those specified in method 5005 of MIL-STD-883 and herein for groups A, B, C, D, and E inspections (see 4.4.1 through 4.4.4). Technology conformance inspection for classes Q and V shall be in accordance with MIL-I-38535 or as specified in the QM plan including groups A, B, C, D, and E inspections and as specified herein except where option 2 of MIL-I-38535 permits alternate in-line control testing.

STANDARD
MICROCIRCUIT DRAWING
DEFENSE ELECTRONICS SUPPLY CENTER
DAYTON, OHIO 45444

SIZE
A

5962-96679

REVISION LEVEL

SHEET

5

TABLE I. Electrical performance characteristics.

Test	Symbol	Conditions -55°C ≤ T _C ≤ +125°C unless otherwise specified	Device type	Group A subgroups	Limits		Units
					Min	Max	
Supply current	I _{DD}	V _{DD} = 5 V V _{IN} = 0.0 V or V _{DD}	ALL	1, 3 1/		5.0	μA
				2 1/		150	
		V _{DD} = 10 V V _{IN} = 0.0 V or V _{DD}	ALL	1, 3 1/		10.0	
				2 1/		300	
		V _{DD} = 15 V V _{IN} = 0.0 V or V _{DD}	ALL	1, 3 1/		10.0	
				2 1/		600	
		V _{DD} = 20 V, V _{IN} = 0.0 V or V _{DD}	ALL	1		10	
2				1000			
M, D, L, R 2/	ALL	1		25			
V _{DD} = 18 V, V _{IN} = 0.0 V or V _{DD}	ALL	3		10.0			
ON-State resistance R _L = 10K returned to V _{DD} - V _{SS} /2	R _{ON}	V _{DD} = 5 V V _{IS} = V _{SS} to V _{DD}	ALL	1		1050	Ω
				2		1300	
				3		800	
		V _{DD} = 10 V V _{IS} = V _{SS} to V _{DD}	ALL	1		400	
				2		500	
				3		310	
		V _{DD} = 15 V V _{IS} = V _{SS} to V _{DD}	ALL	1		240	
				2		320	
				3		220	

See footnotes at end of table.

STANDARD MICROCIRCUIT DRAWING DEFENSE ELECTRONICS SUPPLY CENTER DAYTON, OHIO 45444	SIZE A		5962-96679
		REVISION LEVEL	SHEET 6

DESC FORM 193A
JUL 94

9004708 0018369 082

TABLE I. Electrical performance characteristics.

查询"5962R9667901V1C"供应商

Test	Symbol	Conditions -55°C ≤ T _C ≤ +125°C unless otherwise specified	Device type	Group A subgroups	Limits		Unit
					Min	Max	
Input voltage	V _{IL}	V _{DD} = 5 V = V _{IS} thru 1K V _{EE} = V _{SS} R _L = 1K to V _{SS} I _{IS} < 2 μA on all OFF channels	All	1, 2, 3		1.5	V
		V _{DD} = V _{IS} = 10 V V _{EE} = V _{SS} R _L = 1K to V _{SS} I _{IS} < 2 μA on all 1/ ON OFF channel				3	
		V _{DD} = 15 V = V _{IS} thru 1K V _{EE} = V _{SS} R _L = 1K to V _{SS} I _{IS} < 2 μA on all OFF channels				4	
	V _{IH}	V _{DD} = 5 V = V _{IS} thru 1K V _{EE} = V _{SS} R _L = 1K to V _{SS} I _{IS} < 2 μA on all OFF channels	All	1, 2, 3	3.5		
		V _{DD} = V _{IS} = 10 V V _{EE} = V _{SS} R _L = 1K to V _{SS} I _{IS} < 2 μA on all 1/ ON OFF channel				7	
		V _{DD} = 15 V = V _{IS} thru 1K V _{EE} = V _{SS} R _L = 1K to V _{SS} I _{IS} < 2 μA on all OFF channels				11	
Input leakage current, low	I _{IL}	V _{IN} = V _{DD} or GND, V _{DD} = 20 V	All	1	-100	nA	
		V _{IN} = V _{DD} or GND, V _{DD} = 20 V		2	-1000		
		V _{IN} = V _{DD} or GND, V _{DD} = 18 V		3	-100		
Input leakage current, high	I _{IH}	V _{IN} = V _{DD} or GND, V _{DD} = 20 V	All	1		100	
		V _{IN} = V _{DD} or GND, V _{DD} = 20 V		2		1000	
		V _{IN} = V _{DD} or GND, V _{DD} = 18 V		3		100	
OFF channel leakage any channel OFF or all channels OFF (COMMON out/in)	I _{OZL}	V _{IN} = V _{DD} or GND, V _{DD} = 20 V V _{OUT} = 0 V	All	1	-0.1	μA	
		V _{IN} = V _{DD} or GND, V _{DD} = 20 V V _{OUT} = 0 V		2	-1.0		
		V _{IN} = V _{DD} or GND, V _{DD} = 18 V V _{OUT} = 0 V		3	-0.1		

See footnotes at end of table.

STANDARD MICROCIRCUIT DRAWING DEFENSE ELECTRONICS SUPPLY CENTER DAYTON, OHIO 45444	SIZE A		5962-96679
		REVISION LEVEL	SHEET 7

DESC FORM 193A
JUL 94

9004708 0018370 8T4

TABLE I. Electrical performance characteristics - Continued.

查询"5962R9667901V/LC"供应商

Test	Symbol	Conditions -55°C ≤ T _C ≤ +125°C unless otherwise specified	Device type	Group A subgroups	Limits		Unit
					Min	Max	
OFF channel leakage any channel OFF or all channels OFF (COMMON out/in)	I _{OZH}	V _{IN} = V _{DD} or GND, V _{DD} = 20 V V _{OUT} = V _{DD}	All	1		0.1	μA
		V _{IN} = V _{DD} or GND, V _{DD} = 20 V V _{OUT} = V _{DD}		2		1.0	
		V _{IN} = V _{DD} or GND, V _{DD} = 18 V V _{OUT} = V _{DD}		3		0.1	
N threshold voltage	V _{NTH}	V _{DD} = 10 V, I _{SS} = -10 μA	All	1	-0.7	-2.8	V
		M, D, L, R 2/	All	1	-0.2	-2.8	
N threshold voltage, delta	ΔV _{NTH}	V _{DD} = 10 V, I _{SS} = -10 μA, M, D, L, R 2/	All	1		±1.0	
P threshold voltage	V _{PTH}	V _{SS} = 0.0 V, I _{DD} = 10 μA	All	1	0.7	2.8	
		M, D, L, R 2/	All	1	0.2	2.8	
P threshold voltage, delta	ΔV _{PTH}	V _{SS} = 0.0 V, I _{DD} = 10 μA M, D, L, R 2/	All	1		±1.0	
Functional tests 3/		V _{DD} = 2.8 V, V _{IN} = V _{DD} or GND	All	7	V _{OH} > V _{DD} /2	V _{OL} < V _{DD} /2	V
		V _{DD} = 20 V, V _{IN} = V _{DD} or GND		7			
		V _{DD} = 18 V, V _{IN} = V _{DD} or GND	All	8A			
		M, D, L, R 2/	All	7			
		V _{DD} = 3.0 V, V _{IN} = V _{DD} or GND	All	8B			
		M, D, L, R 2/	All	7			
Input capacitance	C _{IN} 1/	Any input, See 4.4.1c	All	4		7.5	pF

See footnotes at end of table.

STANDARD MICROCIRCUIT DRAWING DEFENSE ELECTRONICS SUPPLY CENTER DAYTON, OHIO 45444	SIZE A		5962-96679
		REVISION LEVEL	SHEET 8

DESC FORM 193A
JUL 94

9004708 0018371 730

TABLE I. Electrical performance characteristics - Continued.

查询"5962R9667901VLC"供应商

Test	Symbol	Conditions -55°C ≤ T _C ≤ +125°C unless otherwise specified	Device type	Group A subgroups	Limits		Unit
					Min	Max	
Propagation delay time, (signal in to output) 4/	t _{PHL} , t _{PLH}	V _{DD} = 5.0 V, V _{IN} = V _{DD} or GND	All	9		60	ns
				10, 11		81	
Propagation delay time, address or inhibit to signal out (Channel turning on) 5/	t _{PZH} , t _{PZL}	V _{DD} = 5.0 V, V _{IN} = V _{DD} or GND	All	9		650	ns
				10, 11		878	
Propagation delay time, address or inhibit to signal out (Channel turning off) 1/ 6/	t _{PHZ} , t _{PLZ}	V _{DD} = 5.0 V, V _{IN} = V _{DD} or GND	All	9		440	ns
				10, 11		597	
Propagation delay time, (signal in to output) 1/ 4/	t _{PHL} , t _{PLH}	V _{DD} = 10 V V _{IS} = V _{DD} = GND	All	9		30	ns
		V _{DD} = 15 V V _{IS} = V _{DD} = GND		9		20	
Propagation delay time, address or inhibit to signal out (Channel turning on) 1/ 5/	t _{PZH} , t _{PZL}	V _{DD} = 10 V	All	9		270	ns
		V _{DD} = 15 V		9		190	
Propagation delay time, address or inhibit to signal out (Channel turning off) 1/ 6/	t _{PHZ} , t _{PLZ}	V _{DD} = 10 V	All	9		180	ns
		V _{DD} = 15 V		9		130	

1/ These tests are controlled via design or process and are not directly tested. These parameters are characterized on initial design release and upon design changes which affect these characteristics.

2/ Devices supplied to this drawing will meet all levels M, D, L, R of irradiation. However, this device is only tested at the 'R' level. When performing post irradiation electrical measurements for any RHA level, T_A = +25°C.

3/ V_{DD} = 2.8/3.0 V, R_L = 200 KΩ.
V_{DD} = 20/18 V, R_L = 10 KΩ - 25 KΩ.

4/ C_L = 50 pF, R_L = 200 KΩ, Input t_r, t_f < 20 ns.

5/ C_L = 50 pF, R_L = 10 KΩ, Input t_r, t_f < 20 ns.

6/ C_L = 50 pF, R_L = 300Ω, t_r, t_f < 20 ns.

STANDARD MICROCIRCUIT DRAWING DEFENSE ELECTRONICS SUPPLY CENTER DAYTON, OHIO 45444	SIZE A		5962-96679
		REVISION LEVEL	SHEET 9

DESC FORM 193A
JUL 94

9004708 0018372 677

[查询"5962R9667901VLC"供应商](#)

Device type	01
Case outlines	L and X
Terminal number	Terminal symbol
1	COMMON OUT/IN
2	*7
3	*6
4	*5
5	*4
6	*3
7	*2
8	*1
9	*0
10	A
11	B
12	V _{SS}
13	D
14	C
15	INHIBIT
16	*15
17	*14
18	*13
19	*12
20	*11
21	*10
22	*9
23	*8
24	V _{DD}

Pins 2 thru 9 *CHANNEL IN/OUT
 Pins 16 thru 23 *CHANNEL IN/OUT

FIGURE 1. Terminal connections.

STANDARD MICROCIRCUIT DRAWING DEFENSE ELECTRONICS SUPPLY CENTER DAYTON, OHIO 45444	SIZE A		5962-96679
		REVISION LEVEL	SHEET 10

DESC FORM 193A
 JUL 94

9004708 0018373 503

[查询"5962R9667901VLC"供应商](#)

Device type	02
Case outlines	L and X
Terminal number	Terminal symbol
1	COMMON X OUT/IN
2	7
3	6
4	5
5	4
6	3
7	2
8	1
9	0
10	A
11	B
12	V _{SS}
13	INHIBIT
14	C
15	7
16	6
17	COMMON Y OUT/IN
18	5
19	4
20	3
21	2
22	1
23	0
24	V _{DD}

Pins 2 thru 9 CHANNEL X IN/OUT
 Pins 15 and 16 Y CHANNEL IN/OUT
 Pins 18 thru 23 Y CHANNEL IN/OUT

FIGURE 1. Terminal connections.- Continued

STANDARD MICROCIRCUIT DRAWING DEFENSE ELECTRONICS SUPPLY CENTER DAYTON, OHIO 45444	SIZE A		5962-96679
		REVISION LEVEL	SHEET 11

DESC FORM 193A
 JUL 94

9004708 0018374 44T

Device type 01

[查询"5962R9667901VLC"供应商](#)

A	B	C	D	Inh	Selected Channel
X	X	X	X	1	None
0	0	0	0	0	0
1	0	0	0	0	1
0	1	0	0	0	2
1	1	0	0	0	3
0	0	1	0	0	4
1	0	1	0	0	5
0	1	1	0	0	6
1	1	1	0	0	7
0	0	0	1	0	8
1	0	0	1	0	9
0	1	0	1	0	10
1	1	0	1	0	11
0	0	1	1	0	12
1	0	1	1	0	13
0	1	1	1	0	14
1	1	1	1	0	15

FIGURE 2. Truth table.

STANDARD MICROCIRCUIT DRAWING DEFENSE ELECTRONICS SUPPLY CENTER DAYTON, OHIO 45444	SIZE A		5962-96679
		REVISION LEVEL	SHEET 12

DESC FORM 193A
JUL 94

9004708 0018375 386

[查询"5962R9667901VLC"供应商](#)

A	B	C	Inh	Selected channel
X	X	X	1	None
0	0	0	0	0X,0Y
1	0	0	0	1X,1Y
0	1	0	0	2X,2Y
1	1	0	0	3X,3Y
0	0	1	0	4X,4Y
1	0	1	0	5X,5Y
0	1	1	0	6X,6Y
1	1	1	0	7X,7Y

FIGURE 2. Truth table. - Continued

STANDARD MICROCIRCUIT DRAWING DEFENSE ELECTRONICS SUPPLY CENTER DAYTON, OHIO 45444	SIZE A		5962-96679
		REVISION LEVEL	SHEET 13

DESC FORM 193A
JUL 94

■ 9004708 0018376 212 ■

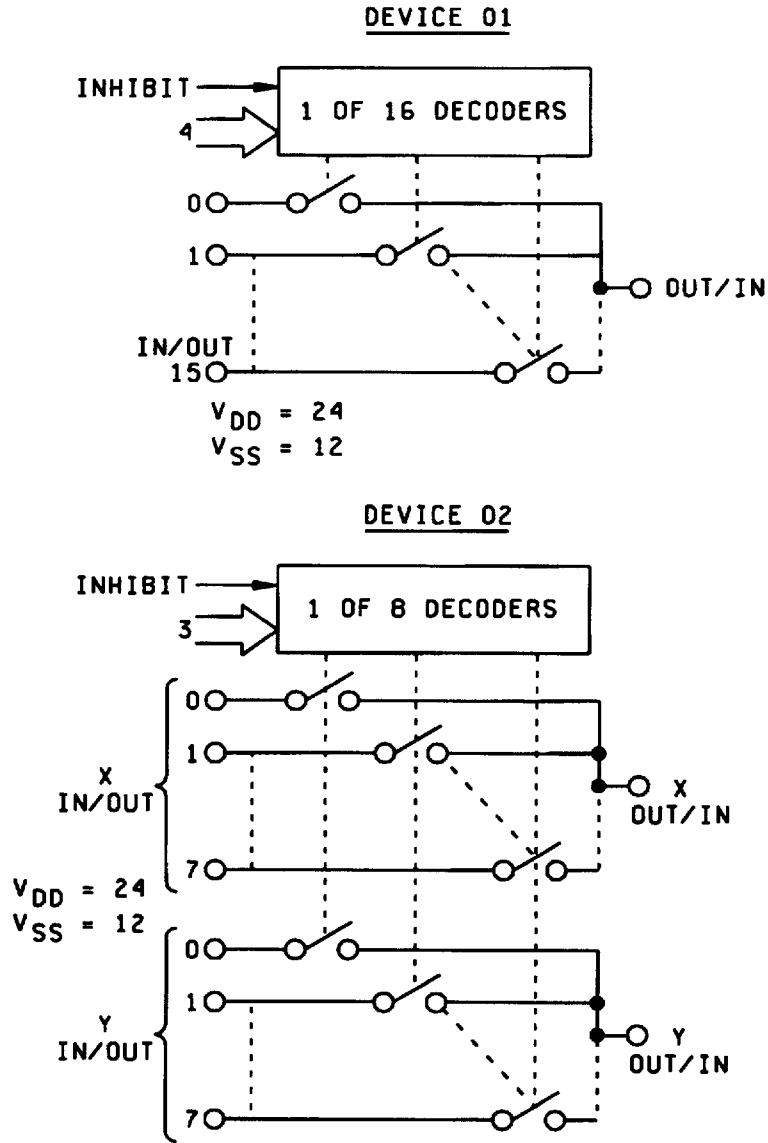

FIGURE 3. Block diagrams.

STANDARD
MICROCIRCUIT DRAWING
DEFENSE ELECTRONICS SUPPLY CENTER
DAYTON, OHIO 45444

SIZE
A

5962-96679

REVISION LEVEL

SHEET

14

4.4.1 Group A inspection.

Tests shall be as specified in table IIA herein.

- b. For device class M, subgroups 7 and 8 tests shall be sufficient to verify the truth table in figure 2 herein. For device classes Q and V, subgroups 7 and 8 shall include verifying the functionality of the device.
- c. Subgroup 4 (C_{IN} measurement) shall be measured only for the initial qualification and after process or design changes which may affect capacitance. C_{IN} shall be measured between the designated terminal and GND at a frequency of 1 MHz. Tests shall be sufficient to validate the limits defined in table I herein.

4.4.2 Group C inspection. The group C inspection end-point electrical parameters shall be as specified in table IIA herein.

4.4.2.1 Additional criteria for device class M. Steady-state life test conditions, method 1005 of MIL-STD-883:

- a. Test condition A, B, C or D. The test circuit shall be maintained by the manufacturer under document revision level control and shall be made available to the preparing or acquiring activity upon request. The test circuit shall specify the inputs, outputs, biases, and power dissipation, as applicable, in accordance with the intent specified in test method 1005.
- b. $T_A = +125^\circ\text{C}$, minimum.
- c. Test duration: 1,000 hours, except as permitted by method 1005 of MIL-STD-883.

4.4.2.2 Additional criteria for device classes Q and V. The steady-state life test duration, test condition and test temperature, or approved alternatives shall be as specified in the device manufacturer's QM plan in accordance with MIL-I-38535. The test circuit shall be maintained under document revision level control by the device manufacturer's TRB, in accordance with MIL-I-38535, and shall be made available to the acquiring or preparing activity upon request. The test circuit shall specify the inputs, outputs, biases, and power dissipation, as applicable, in accordance with the intent specified in test method 1005.

4.4.3 Group D inspection. The group D inspection end-point electrical parameters shall be as specified in table IIA herein.

4.4.4 Group E inspection. Group E inspection is required only for parts intended to be marked as radiation hardness assured (see 3.5 herein). RHA levels for device classes M, Q and V shall be as specified in MIL-I-38535. End-point electrical parameters shall be as specified in table IIA herein.

4.4.4.1 Total dose irradiation testing. Total dose irradiation testing shall be performed in accordance with MIL-STD-883 method 1019 and as specified herein.

4.4.4.1.1 Accelerated aging test. Accelerated aging tests shall be performed on all devices requiring a RHA level greater than 5k rads(Si). The post-anneal end-point electrical parameter limits shall be as specified in table I herein and shall be the pre-irradiation end-point electrical parameter limit at $+25^\circ\text{C} \pm 5^\circ\text{C}$. Testing shall be performed at initial qualification and after any design or process changes which may affect the RHA response of the device.

4.4.4.2 Dose rate induced latchup testing. Dose rate induced latchup testing shall be performed in accordance with test method 1020 of MIL-STD-883 and as specified herein (see 1.4 herein). Tests shall be performed on devices, SEC, or approved test structures at technology qualification and after any design or process changes which may effect the RHA capability of the process.

4.4.4.3 Dose rate upset testing. Dose rate upset testing shall be performed in accordance with test method 1021 of MIL-STD-883 and herein (see 1.4 herein).

- a. Transient dose rate upset testing shall be performed at initial qualification and after any design or process changes which may effect the RHA performance of the devices. Test 10 devices with 0 defects unless otherwise specified.
- b. Transient dose rate upset testing for class Q and V devices shall be performed as specified by a TRB approved radiation hardness assurance plan and MIL-I-38535.

STANDARD MICROCIRCUIT DRAWING DEFENSE ELECTRONICS SUPPLY CENTER DAYTON, OHIO 45444	SIZE A		5962-96679
		REVISION LEVEL	SHEET 15

DESC FORM 193A
JUL 94

9004708 0018378 095

TABLE IIA. Electrical test requirements.

Test requirements	Subgroups (in accordance with MIL-STD-883, TM 5005, table I)	Subgroups (in accordance with MIL-I-38535, table III)	
	Device class M	Device class Q	Device class V
Interim electrical parameters (see 4.2)	1,7,9	1,7,9	1,7,9
Final electrical parameters (see 4.2)	1,2,3,7,8,9,10,11 1/	1,2,3,7,8,9,10,11 1/	1,2,3,7,8,9,10,11 2/ 3/
Group A test requirements (see 4.4)	1,2,3,4,7,8,9,10,11	1,2,3,4,7,8,9,10,11	1,2,3,4,7,8,9,10,11
Group C end-point electrical parameters (see 4.4)	1,2,3,7,8,9,10,11	1,2,3,7,8,9,10,11	1,2,3,7,8,9,10,11 3/
Group D end-point electrical parameters (see 4.4)	1,7,9	1,7,9	1,7,9
Group E end-point electrical parameters (see 4.4)	1,7,9	1,7,9	1,7,9

1/ PDA applies to subgroup 1 and 7.

2/ PDA applies to subgroups 1, 7 and 9 and deltas.

3/ Delta limits as specified in table IIB shall be required where specified, and the delta limits shall be completed with reference to the zero hour electrical parameters (see Table I)

Table IIB. Burn-in and operating life test Delta parameters (+25°C)

Parameter	Symbol	Delta Limits
Supply current	I_{DD}	$\pm 1.0 \mu A$
ON Resistance $V_{DD} = 10 V$	RONDEL 10	$\pm 20\%$

4.4.4.4 Single event phenomena (SEP). SEP testing shall be required on class V devices (see 1.4 herein). SEP testing shall be performed on a technology process on the Standard Evaluation Circuit (SEC) or alternate SEP test vehicle as approved by the qualifying activity at initial qualification and after any design or process changes which may affect the upset or latchup characteristics. The recommended test conditions for SEP are as follows:

- a. The ion beam angle of incidence shall be between normal to the die surface and 60° to the normal, inclusive (i.e. $0^\circ \leq \text{angle} \leq 60^\circ$). No shadowing of the ion beam due to fixturing or package related effects is allowed.
- b. The fluence shall be ≥ 100 errors or $\geq 10^6$ ions/cm².
- c. The flux shall be between 10^2 and 10^5 ions/cm²/s. The cross-section shall be verified to be flux independent by measuring the cross-section at two flux rates which differ by at least an order of magnitude.
- d. The particle range shall be ≥ 20 microns in silicon.
- e. The test temperature shall be +25°C and the maximum rated operating temperature $\pm 10^\circ C$.
- f. Bias conditions shall be defined by the manufacturer for latchup measurements.
- g. Test four devices with zero failures.

STANDARD MICROCIRCUIT DRAWING DEFENSE ELECTRONICS SUPPLY CENTER DAYTON, OHIO 45444	SIZE A		5962-96679
		REVISION LEVEL	SHEET 16

Table III. Irradiation test connections. 1/

查询"5962R9667901VLC"供应商

Device type	Open	Ground	V _{DD} = 10 V ±0.5 V
01	1	12	2,3,4,5,6,7,8,9,10,11, 13,14,15,16,17,18,19, 20,21,22,23,24

Device type	Open	Ground	V _{DD} = 10 V ±0.5 V
02	1,17	12	2,3,4,5,6,7,8,9,10,11,13 ,14,15,16,18,19,20,21,22 ,23,24

1/ Each pin except V_{DD} and GND will have a series resistor of 47 KΩ ±5%, for irradiation testing.

4.5 Methods of inspection. Methods of inspection shall be as specified as follows:

4.5.1 Voltage and current. Unless otherwise specified, all voltages given are referenced to the microcircuit GND terminal. Currents given are conventional current and positive when flowing into the referenced terminal.

5. PACKAGING

5.1 Packaging requirements. The requirements for packaging shall be in accordance with MIL-STD-883 (see 3.1 herein) for device class M and MIL-I-38535 for device classes Q and V.

6. NOTES

6.1 Intended use. Microcircuits conforming to this drawing are intended for use for Government microcircuit applications (original equipment), design applications, and logistics purposes.

6.1.1 Replaceability. Microcircuits covered by this drawing will replace the same generic device covered by a contractor-prepared specification or drawing.

6.1.2 Substitutability. Device class Q devices will replace device class M devices.

6.2 Configuration control of SMD's. All proposed changes to existing SMD's will be coordinated with the users of record for the individual documents. This coordination will be accomplished in accordance with MIL-STD-973 using DD Form 1692, Engineering Change Proposal.

6.3 Record of users. Military and industrial users shall inform Defense Electronics Supply Center when a system application requires configuration control and which SMD's are applicable to that system. DESC will maintain a record of users and this list will be used for coordination and distribution of changes to the drawings. Users of drawings covering microelectronic devices (FSC 5962) should contact DESC-EC, telephone (513) 296-6047.

6.4 Comments. Comments on this drawing should be directed to DESC-EC, Dayton, Ohio 45444-5270, or telephone (513) 296-8525.

6.5 Abbreviations, symbols, and definitions. The abbreviations, symbols, and definitions used herein are defined in MIL-I-38535 and MIL-STD-1331.

STANDARD MICROCIRCUIT DRAWING DEFENSE ELECTRONICS SUPPLY CENTER DAYTON, OHIO 45444	SIZE A		5962-96679
		REVISION LEVEL	SHEET 17

DESC FORM 193A
JUL 94

9004708 0018380 743

6.6 One part - one part number system. The one part - one part number system described below has been developed to allow for transitions between identical generic devices covered by the three major microcircuit requirements documents (MIL-STD-883, QML-38534, and MIL-STD-883) without the necessity for the generation of unique PIN's. The three military requirements documents represent different class levels, and previously when a device manufacturer upgraded military product from one class level to another, the benefits of the upgraded product were unavailable to the Original Equipment Manufacturer (OEM), that was contractually locked into the original unique PIN. By establishing a one part number system covering all three documents, the OEM can acquire to the highest class level available for a given generic device to meet system needs without modifying the original contract parts selection criteria.

<u>Military documentation format</u>	<u>Example PIN under new system</u>	<u>Manufacturing source listing</u>	<u>Document listing</u>
New MIL-H-38534 Standard Microcircuit Drawings	5962-XXXXXZZ(H or K)YY	QML-38534	MIL-BUL-103
New MIL-I-38535 Standard Microcircuit Drawings	5962-XXXXXZZ(Q or V)YY	QML-38535	MIL-BUL-103
New 1.2.1 of MIL-STD-883 Standard Microcircuit Drawings	5962-XXXXXZZ(M)YY	MIL-BUL-103	MIL-BUL-103

6.7 Sources of supply.

6.7.1 Sources of supply for device classes Q and V. Sources of supply for device classes Q and V are listed in QML-38535. The vendors listed in QML-38535 have submitted a certificate of compliance (see 3.6 herein) to DESC-EC and have agreed to this drawing.

6.7.2 Approved sources of supply for device class M. Approved sources of supply for class M are listed in MIL-BUL-103. The vendors listed in MIL-BUL-103 have agreed to this drawing and a certificate of compliance (see 3.6 herein) has been submitted to and accepted by DESC-EC.

6.8 Additional information. A copy of the following additional data shall be maintained and available from the device manufacturer:

- a. RHA upset levels.
- b. Test conditions (SEP).
- c. Number of upsets (SEP).
- d. Number of transients (SEP).
- e. Occurrence of latchup (SEP).

STANDARD MICROCIRCUIT DRAWING DEFENSE ELECTRONICS SUPPLY CENTER DAYTON, OHIO 45444	SIZE A		5962-96679
		REVISION LEVEL	SHEET 18