

RF LDMOS Wideband Integrated Power Amplifiers

The MW7IC2750N wideband integrated circuit is designed with on-chip matching that makes it usable from 2300- 2700 MHz. This multi-stage structure is rated for 26 to 32 Volt operation and covers all typical cellular base station modulation formats.

- Typical WiMAX Performance: $V_{DD} = 28$ Volts, $I_{DQ1} = 160$ mA, $I_{DQ2} = 550$ mA, $P_{out} = 8$ Watts Avg., $f = 2700$ MHz, OFDM 802.16d, 64 QAM $3/4$, 4 Bursts, 10 MHz Channel Bandwidth, Input Signal PAR = 9.5 dB @ 0.01% Probability on CCDF.
 Power Gain — 26 dB
 Power Added Efficiency — 17%
 Device Output Signal PAR — 8.6 dB @ 0.01% Probability on CCDF
 ACPR @ 8.5 MHz Offset — -49 dBc in 1 MHz Channel Bandwidth
- Capable of Handling 10:1 VSWR, @ 32 Vdc, 2600 MHz, 80 Watts CW Output Power (3 dB Input Overdrive from Rated P_{out})
- Stable into a 3:1 VSWR. All Spurs Below -60 dBc @ 1 mW to 80 W CW P_{out}
- Typical P_{out} @ 1 dB Compression Point \approx 50 Watts CW

Driver Applications

- Typical WiMAX Performance: $V_{DD} = 28$ Volts, $I_{DQ1} = 160$ mA, $I_{DQ2} = 550$ mA, $P_{out} = 4$ Watts Avg., $f = 2700$ MHz, OFDM 802.16d, 64 QAM $3/4$, 4 Bursts, 10 MHz Channel Bandwidth, Input Signal PAR = 9.5 dB @ 0.01% Probability on CCDF.
 Power Gain — 26 dB
 Power Added Efficiency — 11%
 Device Output Signal PAR — 9.2 dB @ 0.01% Probability on CCDF
 ACPR @ 8.5 MHz Offset — -57 dBc in 1 MHz Channel Bandwidth

Features

- 100% PAR Tested for Guaranteed Output Power Capability
- Characterized with Series Equivalent Large-Signal Impedance Parameters and Common Source S-Parameters
- On-Chip Matching (50 Ohm Input, DC Blocked)
- Integrated Quiescent Current Temperature Compensation with Enable/Disable Function (1)
- Integrated ESD Protection
- Greater Negative Gate-Source Voltage Range for Improved Class C Operation
- 225°C Capable Plastic Package
- RoHS Compliant
- In Tape and Reel. R1 Suffix = 500 Units per 44 mm, 13 inch Reel.

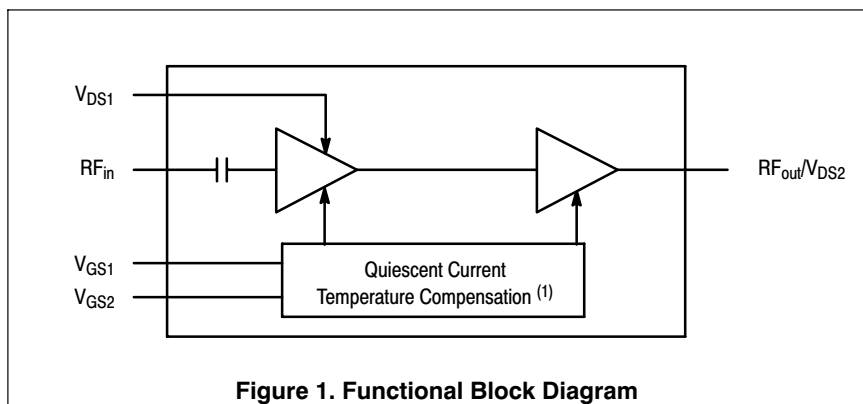

1. Refer to AN1977, *Quiescent Current Thermal Tracking Circuit in the RF Integrated Circuit Family* and to AN1987, *Quiescent Current Control for the RF Integrated Circuit Device Family*. Go to <http://www.freescale.com/rf>. Select Documentation/Application Notes - AN1977 or AN1987.

**MW7IC2750NR1
MW7IC2750GNR1
MW7IC2750NBR1**

**2500-2700 MHz, 8 W AVG., 28 V
WiMAX
RF LDMOS WIDEBAND
INTEGRATED POWER AMPLIFIERS**

**CASE 1618-02
TO-270 WB-14
PLASTIC
MW7IC2750NR1**

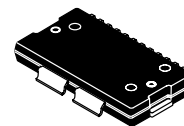
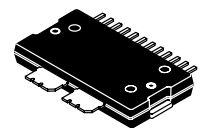

**CASE 1621-02
TO-270 WB-14 GULL
PLASTIC
MW7IC2750GNR1**

**CASE 1617-02
TO-272 WB-14
PLASTIC
MW7IC2750NBR1**

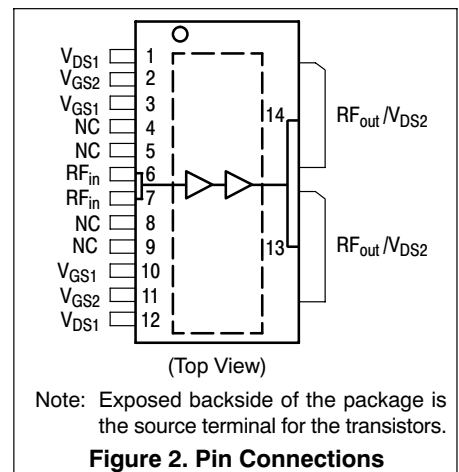
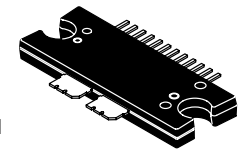

Table 1. Maximum Ratings

Rating	Symbol	Value	Unit
Drain-Source Voltage	V_{DS}	-0.5, +65	Vdc
Gate-Source Voltage	V_{GS}	-6.0, +10	Vdc
Operating Voltage	V_{DD}	32, +0	Vdc
Storage Temperature Range	T_{stg}	-65 to +150	°C
Case Operating Temperature	T_C	150	°C
Operating Junction Temperature (1,2)	T_J	225	°C
Input Power	P_{in}	25	dBm

Table 2. Thermal Characteristics

Characteristic	Symbol	Value (2,3)	Unit
Thermal Resistance, Junction to Case CW Application (Case Temperature 80°C, $P_{out} = 50$ W CW)	$R_{\theta JC}$	Stage 1, 28 Vdc, $I_{DQ1} = 160$ mA	3.0
		Stage 2, 28 Vdc, $I_{DQ2} = 550$ mA	0.7
Final Application (Case Temperature 70°C, $P_{out} = 8$ W CW)		Stage 1, 28 Vdc, $I_{DQ1} = 160$ mA	2.9
		Stage 2, 28 Vdc, $I_{DQ2} = 550$ mA	0.7
Driver Application (Case Temperature 65°C, $P_{out} = 4$ W CW)		Stage 1, 28 Vdc, $I_{DQ1} = 160$ mA	2.8
		Stage 2, 28 Vdc, $I_{DQ2} = 550$ mA	0.7

Table 3. ESD Protection Characteristics

Test Methodology	Class
Human Body Model (per JESD22-A114)	1C (Minimum)
Machine Model (per EIA/JESD22-A115)	A (Minimum)
Charge Device Model (per JESD22-C101)	III (Minimum)

Table 4. Moisture Sensitivity Level

Test Methodology	Rating	Package Peak Temperature	Unit
Per JESD 22-A113, IPC/JEDEC J-STD-020	3	260	°C

Table 5. Electrical Characteristics ($T_A = 25^\circ\text{C}$ unless otherwise noted)

Characteristic	Symbol	Min	Typ	Max	Unit
Stage 1 — Off Characteristics					
Zero Gate Voltage Drain Leakage Current ($V_{DS} = 65$ Vdc, $V_{GS} = 0$ Vdc)	I_{DSS}	—	—	10	μA_{dc}
Zero Gate Voltage Drain Leakage Current ($V_{DS} = 28$ Vdc, $V_{GS} = 0$ Vdc)	I_{DSS}	—	—	1	μA_{dc}
Gate-Source Leakage Current ($V_{GS} = 5$ Vdc, $V_{DS} = 0$ Vdc)	I_{GSS}	—	—	1	μA_{dc}
Stage 1 — On Characteristics					
Gate Threshold Voltage ($V_{DS} = 10$ Vdc, $I_D = 46$ μA_{dc})	$V_{GS(th)}$	1	2	3	Vdc
Gate Quiescent Voltage ($V_{DD} = 28$ Vdc, $I_{DQ1} = 160$ mA, Measured in Functional Test)	$V_{GS(Q)}$	3	3.8	4.5	Vdc
Stage 1 — Dynamic Characteristics (4)					
Input Capacitance ($V_{DS} = 28$ Vdc, $V_{GS} = 0$ Vdc ± 30 mV(rms)ac @ 1 MHz)	C_{iss}	—	550	—	pF

1. Continuous use at maximum temperature will affect MTTF.
2. MTTF calculator available at <http://www.freescale.com/rf>. Select Software & Tools/Development Tools/Calculators to access MTTF calculators by product.
3. Refer to AN1955, *Thermal Measurement Methodology of RF Power Amplifiers*. Go to <http://www.freescale.com/rf>. Select Documentation/Application Notes - AN1955.
4. Part internally matched both on input and output.

(continued)

MW7IC2750NR1 MW7IC2750GNR1 MW7IC2750NBR1

Table 5. Electrical Characteristics ($T_A = 25^\circ\text{C}$ unless otherwise noted) (continued)

Characteristic	Symbol	Min	Typ	Max	Unit
Stage 2 — Off Characteristics					
Zero Gate Voltage Drain Leakage Current ($V_{DS} = 65\text{ Vdc}$, $V_{GS} = 0\text{ Vdc}$)	I_{DSS}	—	—	10	μAdc
Zero Gate Voltage Drain Leakage Current ($V_{DS} = 28\text{ Vdc}$, $V_{GS} = 0\text{ Vdc}$)	I_{DSS}	—	—	1	μAdc
Gate-Source Leakage Current ($V_{GS} = 5\text{ Vdc}$, $V_{DS} = 0\text{ Vdc}$)	I_{GSS}	—	—	1	μAdc

Stage 2 — On Characteristics

Gate Threshold Voltage ($V_{DS} = 10\text{ Vdc}$, $I_D = 185\ \mu\text{Adc}$)	$V_{GS(th)}$	1	2	3	Vdc
Gate Quiescent Voltage ($V_{DD} = 28\text{ Vdc}$, $I_{DQ2} = 550\text{ mA}$, Measured in Functional Test)	$V_{GS(Q)}$	2.8	3.6	4.3	Vdc
Drain-Source On-Voltage ($V_{GS} = 10\text{ Vdc}$, $I_D = 1\text{ Adc}$)	$V_{DS(on)}$	0.1	0.12	0.8	Vdc

Stage 2 — Dynamic Characteristics ⁽¹⁾

Reverse Transfer Capacitance ($V_{DS} = 28\text{ Vdc} \pm 30\text{ mV(rms)ac}$ @ 1 MHz, $V_{GS} = 0\text{ Vdc}$)	C_{rss}	—	0.68	—	pF
Output Capacitance ($V_{DS} = 28\text{ Vdc} \pm 30\text{ mV(rms)ac}$ @ 1 MHz, $V_{GS} = 0\text{ Vdc}$)	C_{oss}	—	220	—	pF

Functional Tests (In Freescale Test Fixture, 50 ohm system) $V_{DD} = 28\text{ Vdc}$, $I_{DQ1} = 160\text{ mA}$, $I_{DQ2} = 550\text{ mA}$, $P_{out} = 8\text{ W Avg.}$, $f = 2700\text{ MHz}$, WiMAX, OFDM 802.16d, 64 QAM $^{3/4}$, 4 Bursts, 10 MHz Channel Bandwidth, Input Signal PAR = 9.5 dB @ 0.01% Probability on CCDF. ACPR measured in 1 MHz Channel Bandwidth @ $\pm 8.5\text{ MHz}$ Offset.

Power Gain	G_{ps}	24	26	31	dB
Power Added Efficiency	PAE	15	17	—	%
Output Peak-to-Average Ratio @ 0.01% Probability on CCDF	PAR	7.8	8.6	—	dB
Adjacent Channel Power Ratio	ACPR	—	-49	-45	dBc
Input Return Loss	IRL	—	-12	-10	dB

Typical Performances OFDM Signal — 10 MHz Channel Bandwidth (In Freescale Test Fixture, 50 ohm system) $V_{DD} = 28\text{ Vdc}$, $I_{DQ1} = 160\text{ mA}$, $I_{DQ2} = 550\text{ mA}$, $P_{out} = 8\text{ W Avg.}$, $f = 2700\text{ MHz}$, WiMAX, OFDM 802.16d, 64 QAM $^{3/4}$, 4 Bursts, 10 MHz Channel Bandwidth, Input Signal PAR = 9.5 dB @ 0.01% Probability on CCDF.

Relative Constellation Error ⁽²⁾	RCE	—	-33	—	dB
Error Vector Magnitude ⁽²⁾	EVM	—	2.3	—	% rms

Typical Performances OFDM Signal — 7 MHz Channel Bandwidth (In Freescale Test Fixture, 50 ohm system) $V_{DD} = 28\text{ Vdc}$, $I_{DQ1} = 160\text{ mA}$, $I_{DQ2} = 550\text{ mA}$, $P_{out} = 8\text{ W Avg.}$, $f = 2700\text{ MHz}$, WiMAX, OFDM 802.16d, 64 QAM $^{3/4}$, 4 Bursts, 7 MHz Channel Bandwidth, Input Signal PAR = 9.5 dB @ 0.01% Probability on CCDF.

Mask System Type G	Mask	—	-27	—	dBc
Point B at 3.5 MHz Offset		—	-40	—	
Point C at 5 MHz Offset		—	-43	—	
Point D at 7.4 MHz Offset		—	-58	—	
Point E at 14 MHz Offset		—	-63	—	
Point F at 17.5 MHz Offset		—		—	
Relative Constellation Error ⁽²⁾	RCE	—	-33	—	dB
Error Vector Magnitude ⁽²⁾	EVM	—	2.3	—	% rms

- Part internally matched both on input and output.
- $RCE = 20\text{Log}(EVM/100)$

(continued)

Table 5. Electrical Characteristics ($T_A = 25^\circ\text{C}$ unless otherwise noted) (continued)

Characteristic	Symbol	Min	Typ	Max	Unit
Typical Performances (In Freescale Test Fixture, 50 ohm system) $V_{DD} = 28\text{ Vdc}$, $I_{DQ1} = 160\text{ mA}$, $I_{DQ2} = 550\text{ mA}$, 2700 MHz Bandwidth					
P_{out} @ 1 dB Compression Point, CW	P1dB	—	55	—	W
IMD Symmetry @ 50 W PEP, P_{out} where IMD Third Order Intermodulation $\cong 30\text{ dBc}$ (Delta IMD Third Order Intermodulation between Upper and Lower Sidebands $> 2\text{ dB}$)	IMD _{sym}	—	60	—	MHz
VBW Resonance Point (IMD Third Order Intermodulation Inflection Point)	VBW _{res}	—	50	—	MHz
Gain Flatness in 200 MHz Bandwidth @ $P_{out} = 8\text{ W Avg.}$	G_F	—	0.5	—	dB
Average Deviation from Linear Phase in 200 MHz Bandwidth @ $P_{out} = 50\text{ W CW}$	Φ	—	1.1	—	$^\circ$
Average Group Delay @ $P_{out} = 50\text{ W CW}$, $f = 2600\text{ MHz}$	Delay	—	2.3	—	ns
Part-to-Part Insertion Phase Variation @ $P_{out} = 50\text{ W CW}$, $f = 2600\text{ MHz}$, Six Sigma Window	$\Delta\Phi$	—	38.7	—	$^\circ$
Gain Variation over Temperature (-30°C to $+85^\circ\text{C}$)	ΔG	—	0.037	—	dB/ $^\circ\text{C}$
Output Power Variation over Temperature (-30°C to $+85^\circ\text{C}$)	$\Delta P1\text{dB}$	—	0.005	—	dBm/ $^\circ\text{C}$

Typical Driver Performances (In Freescale Test Fixture, 50 ohm system) $V_{DD} = 28\text{ Vdc}$, $I_{DQ1} = 160\text{ mA}$, $I_{DQ2} = 550\text{ mA}$, $P_{out} = 4\text{ W Avg.}$, $f = 2700\text{ MHz}$, WiMAX, OFDM 802.16d, 64 QAM $3/4$, 4 Bursts, 10 MHz Channel Bandwidth, Input Signal PAR = 9.5 dB @ 0.01% Probability on CCDF. ACPR measured in 1 MHz Channel Bandwidth @ $\pm 8.5\text{ MHz}$ Offset.

Power Gain	G_{ps}	—	26	—	dB
Power Added Efficiency	PAE	—	11	—	%
Output Peak-to-Average Ratio @ 0.01% Probability on CCDF	PAR	—	9.2	—	dB
Adjacent Channel Power Ratio	ACPR	—	-57	—	dBc
Input Return Loss	IRL	—	-13	—	dB
Relative Constellation Error @ $P_{out} = 2.5\text{ W Avg.}$ (1)	RCE	—	-39	—	dB

1. RCE = $20\text{Log}(EVM/100)$

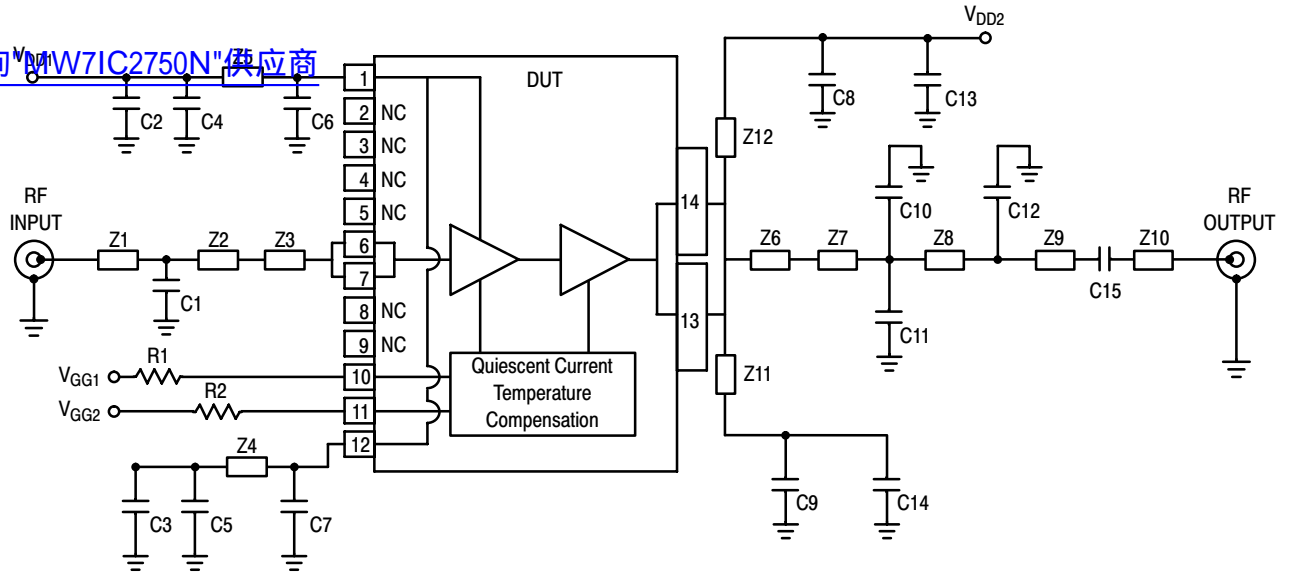

Z1	0.662" x 0.064" Microstrip	Z8	0.417" x 0.064" Microstrip
Z2	1.530" x 0.064" Microstrip	Z9	1.137" x 0.064" Microstrip
Z3	0.126" x 0.060" Microstrip	Z10	0.293" x 0.064" Microstrip
Z4, Z5	0.771" x 0.046" Microstrip	Z11, Z12	0.615" x 0.095" Microstrip
Z6	0.192" x 0.860" Microstrip	PCB	Rogers RO4350B, 0.030", $\epsilon_r = 3.5$
Z7	0.280" x 0.719" Microstrip		

Figure 3. MW7IC2750NR1(GNR1)(NBR1) Test Circuit Schematic

Table 6. MW7IC2750NR1(GNR1)(NBR1) Test Circuit Component Designations and Values

Part	Description	Part Number	Manufacturer
C1	0.8 pF Chip Capacitor	ATC100B0R8BT500XT	ATC
C2, C3, C13, C14	10 μ F, 50 V Chip Capacitors	GRM55DR61H106KA88B	Murata
C4, C5, C8, C9, C15	5.1 pF Chip Capacitors	ATC100B5R1CT500XT	ATC
C6, C7	1 μ F, 100 V Chip Capacitors	GRM32ER72A105KA01L	Murata
C10, C11	0.2 pF Chip Capacitors	ATC100B0R2BT500XT	ATC
C12	0.5 pF Chip Capacitor	ATC100B0R5BT500XT	ATC
R1, R2	1 K Ω , 1/4 W Chip Resistors	CRCW12061001FKEA	Vishay

[查询“MW7IC2750N”供应商](#)

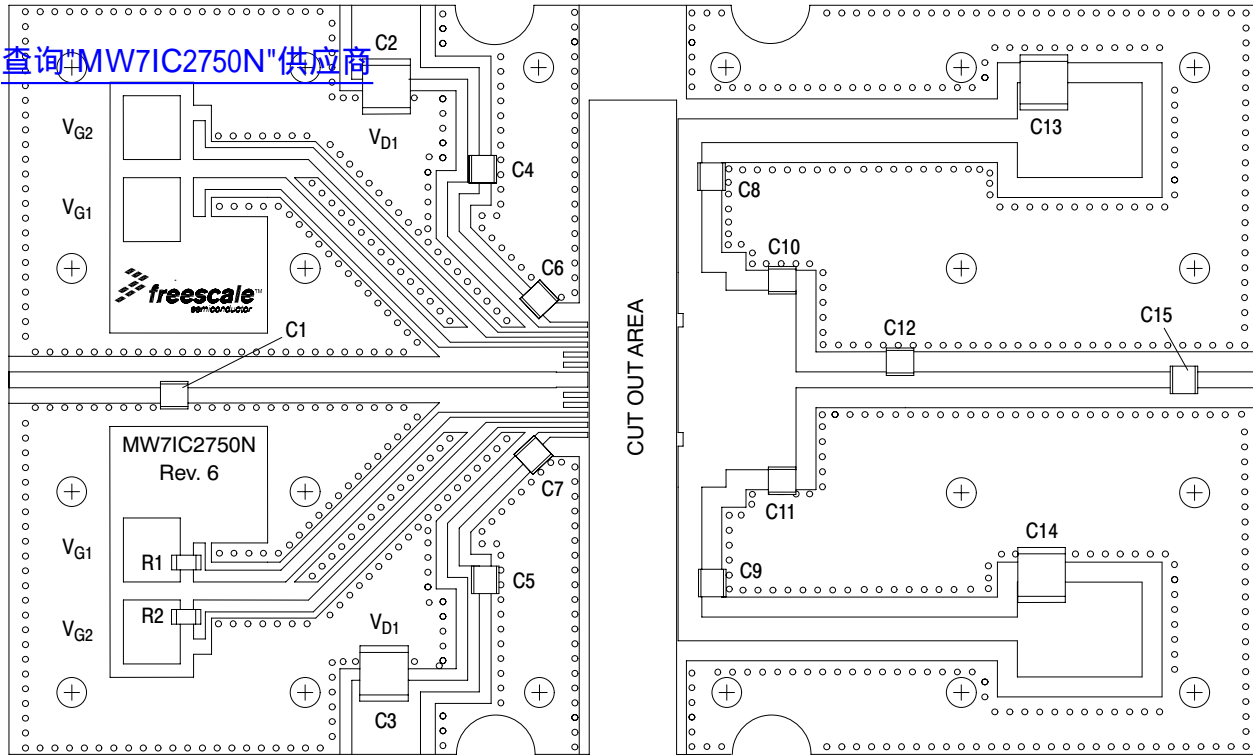

Figure 4. MW7IC2750NR1(GNR1)(NBR1) Test Circuit Component Layout

TYPICAL CHARACTERISTICS

[查询"MW7IC2750N"供应商](#)

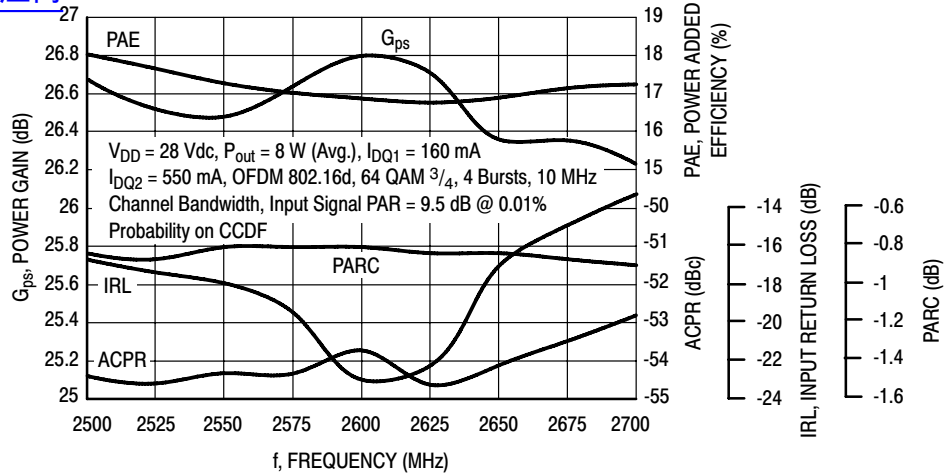

Figure 5. WiMAX Broadband Performance @ $P_{out} = 8$ Watts Avg.

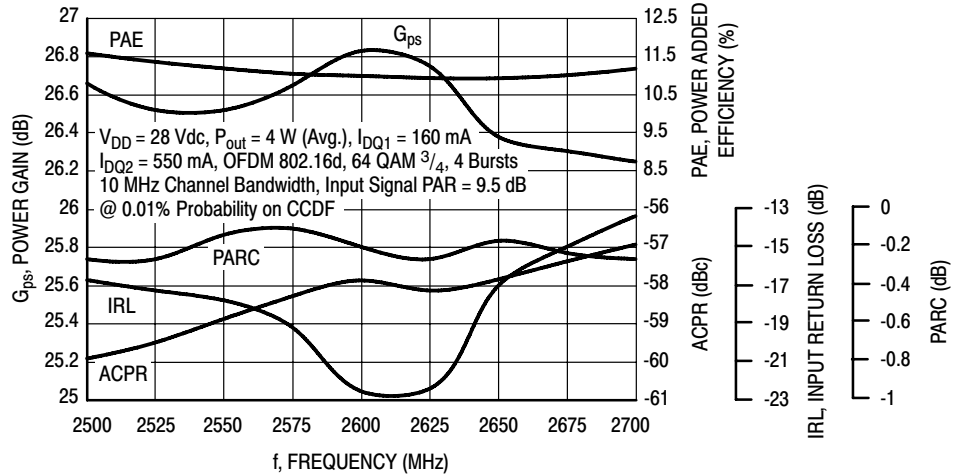

Figure 6. WiMAX Broadband Performance @ $P_{out} = 4$ Watts Avg.

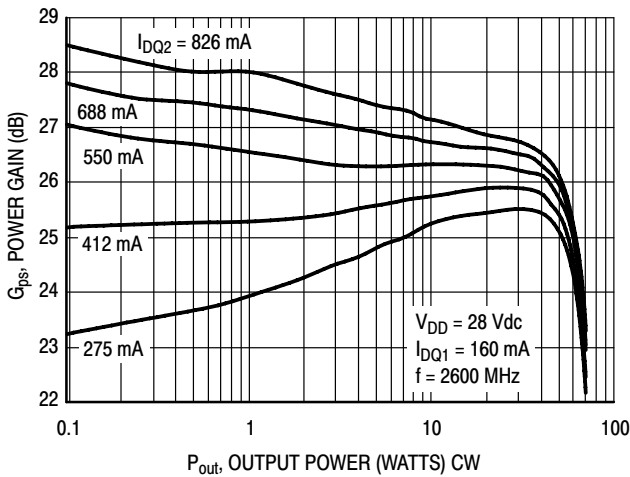

Figure 7. Power Gain versus Output Power @ $I_{DQ1} = 160$ mA

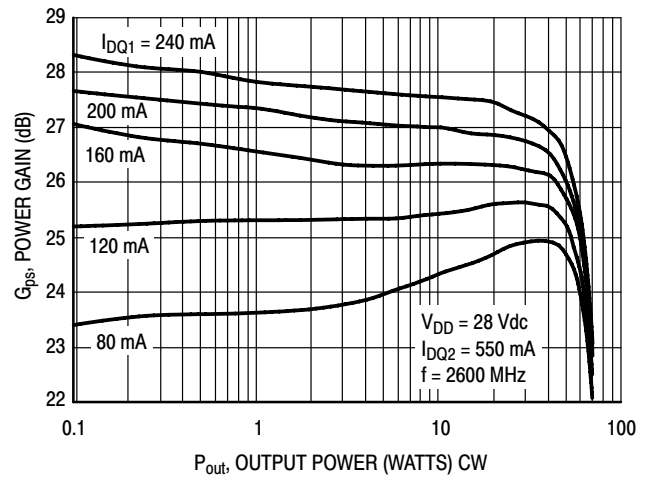

Figure 8. Power Gain versus Output Power @ $I_{DQ2} = 550$ mA

MW7IC2750NR1 MW7IC2750GNR1 MW7IC2750NBR1

TYPICAL CHARACTERISTICS

[查询"MW7IC2750N"供应商](#)

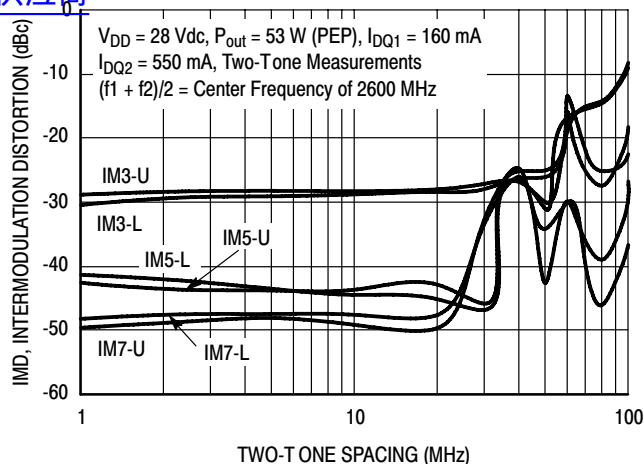

Figure 9. Intermodulation Distortion Products versus Tone Spacing

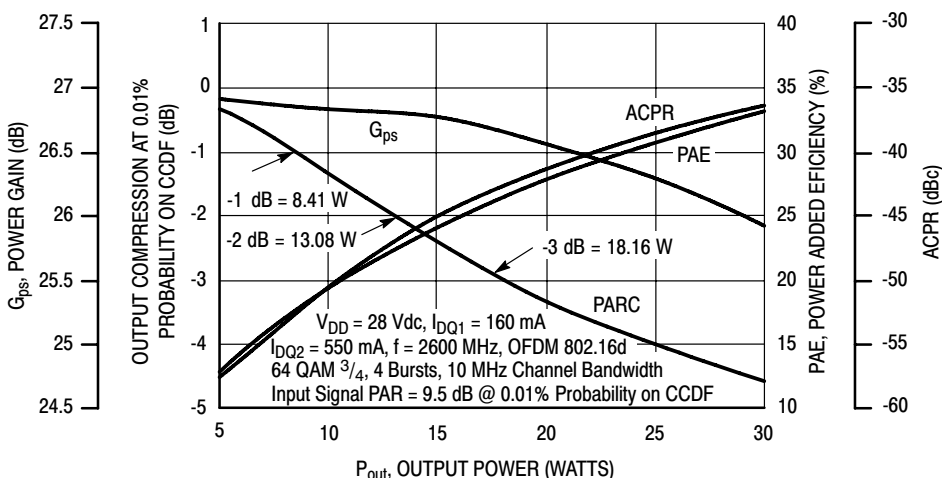

Figure 10. Output Peak-to-Average Ratio Compression (PARC) versus Output Power

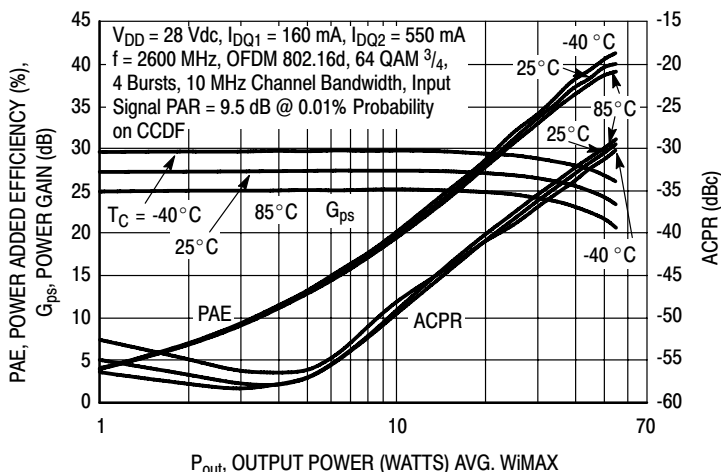

Figure 11. WiMAX, ACPR, Power Gain and Power Added Efficiency versus Output Power

TYPICAL CHARACTERISTICS

[查询"MW7IC2750N"供应商](#)

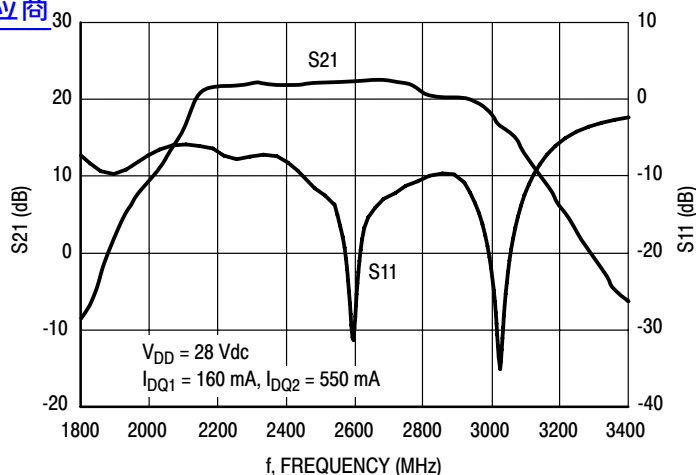
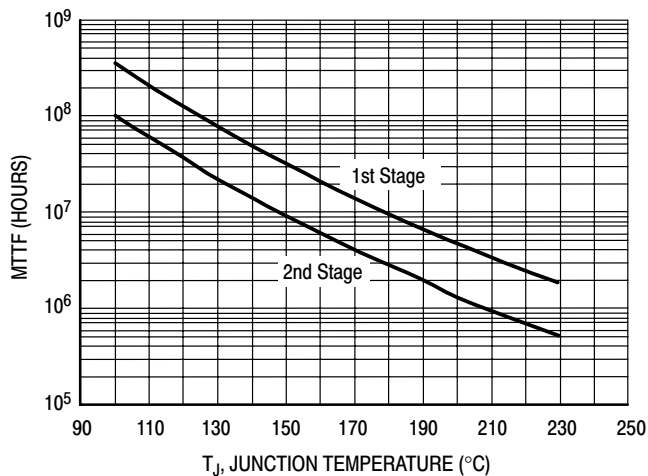

Figure 12. Broadband Frequency Response



This above graph displays calculated MTTF in hours when the device is operated at $V_{DD} = 28 \text{ Vdc}$, $P_{out} = 8 \text{ W Avg.}$, and $PAE = 17\%$.

MTTF calculator available at <http://www.freescale.com/rf>. Select Software & Tools/Development Tools/Calculators to access MTTF calculators by product.

Figure 13. MTTF versus Junction Temperature

WIMAX TEST SIGNAL

[查询"MW7IC2750N"供应商](#)

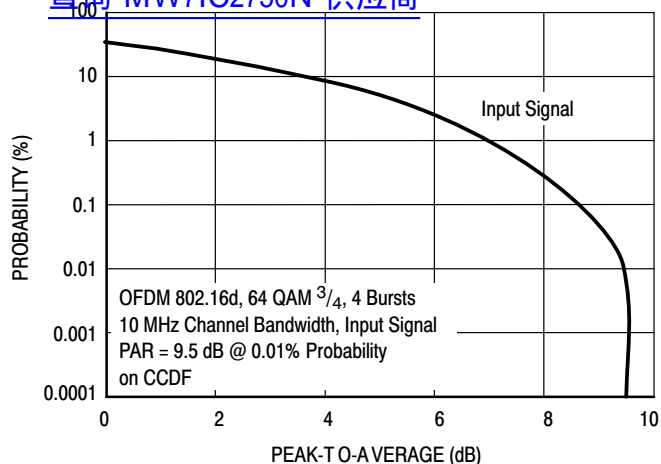

Figure 14. OFDM 802.16d Test Signal

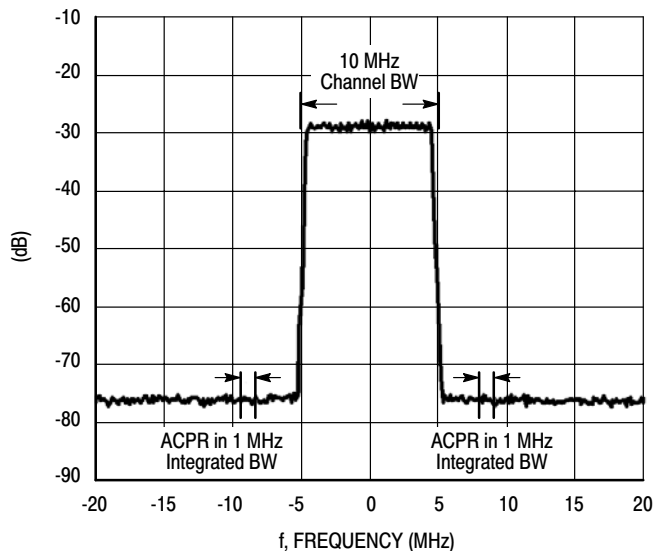
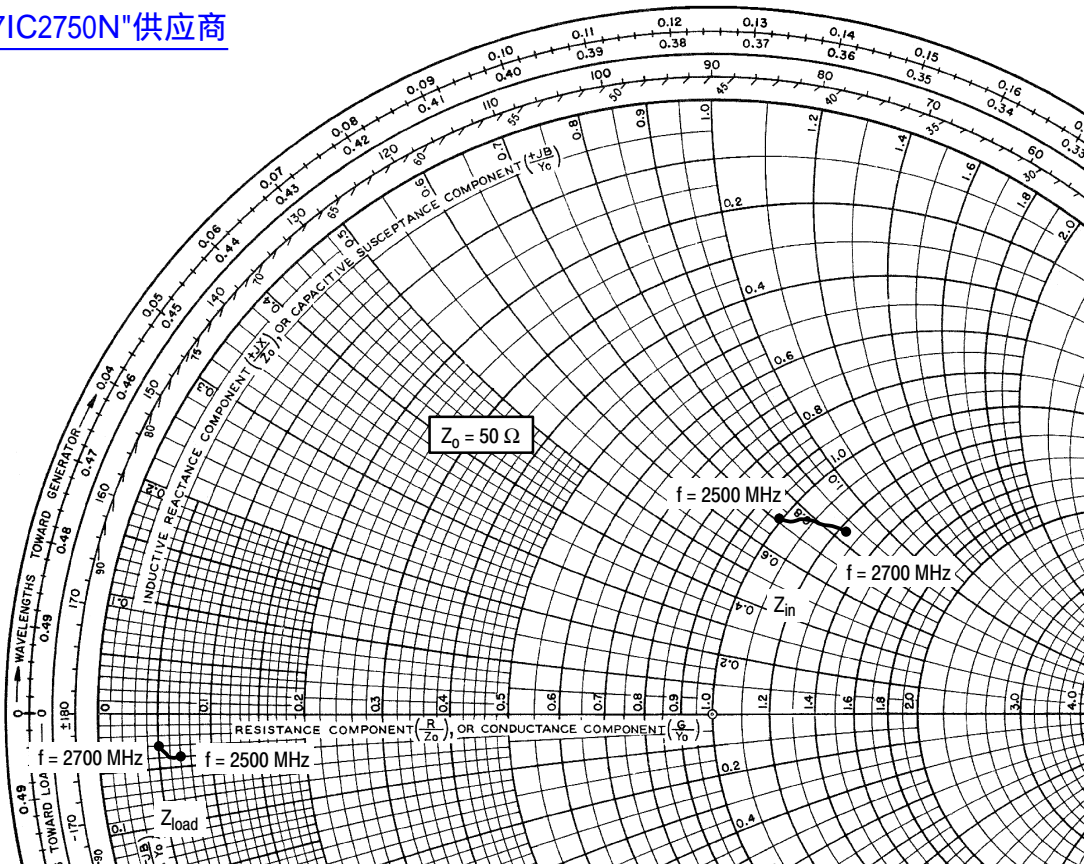

Figure 15. WiMAX Spectrum Mask Specifications



$V_{DD} = 28 \text{ Vdc}$, $I_{DQ1} = 160 \text{ mA}$, $I_{DQ2} = 550 \text{ mA}$, $P_{out} = 8 \text{ W Avg.}$

f MHz	Z_{in} Ω	Z_{load} Ω
2500	49.58 + j35.82	3.52 - j1.79
2525	50.78 + j36.71	3.46 - j1.82
2550	52.04 + j37.58	3.37 - j1.86
2575	53.39 + j38.45	3.24 - j1.88
2600	54.82 + j39.30	3.09 - j1.87
2625	56.35 + j40.14	2.94 - j1.84
2650	57.96 + j40.95	2.77 - j1.77
2675	59.68 + j41.74	2.60 - j1.66
2700	61.50 + j42.49	2.44 - j1.56

Z_{in} = Device input impedance as measured from gate to ground.

Z_{load} = Test circuit impedance as measured from drain to ground.

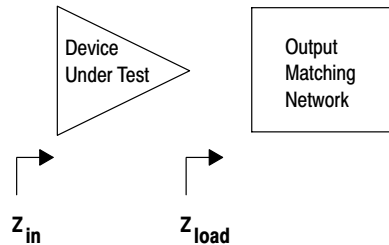

Figure 16. Series Equivalent Source and Load Impedance

Table 7. Common Source S-Parameters ($V_{DD} = 28\text{ V}$, $I_{DQ1} = 160\text{ mA}$, $I_{DQ2} = 550\text{ mA}$, $T_C = 25^\circ\text{C}$, 50 Ohm System)

MHz	S ₁₁		S ₂₁		S ₁₂		S ₂₂	
	S ₁₁	∠φ	S ₂₁	∠φ	S ₁₂	∠φ	S ₂₂	∠φ
1500	0.754	78.5	0.001	-17.9	0.000774	17.4	0.994	174.5
1550	0.734	70.1	0.001	-118.8	0.000326	85.4	0.993	175.3
1600	0.716	61.7	0.003	-116.5	0.000392	58.7	0.998	174.6
1650	0.697	53.4	0.009	-135.3	0.000268	27.8	0.997	173.9
1700	0.677	45.1	0.024	-152.3	0.000211	-33.8	0.996	172.9
1750	0.651	36.6	0.064	-179.9	0.000309	148.0	0.991	171.7
1800	0.619	27.6	0.141	146.0	0.000599	148.7	0.981	170.3
1850	0.578	17.7	0.255	113.0	0.000732	142.6	0.970	169.0
1900	0.527	5.6	0.425	84.8	0.000734	149.1	0.957	167.3
1950	0.462	-9.3	0.701	61.4	0.000911	144.7	0.941	165.6
2000	0.392	-27.8	1.237	39.8	0.00154	174.4	0.924	163.6
2050	0.312	-51.0	2.342	15.9	0.00286	159.0	0.895	160.9
2100	0.218	-74.1	4.772	-11.8	0.00377	142.2	0.843	156.6
2150	0.139	-77.4	11.680	-51.5	0.00588	128.7	0.691	149.4
2200	0.426	-69.8	27.658	-129.7	0.00919	73.9	0.342	-169.4
2250	0.490	-123.5	21.740	150.4	0.00545	38.1	0.800	-166.9
2300	0.416	-146.4	16.087	106.5	0.00314	33.9	0.864	-174.9
2350	0.352	-160.1	13.279	71.6	0.00239	24.9	0.879	-177.0
2400	0.321	-166.6	11.654	41.9	0.00175	33.1	0.891	-177.5
2450	0.274	-173.2	10.543	13.4	0.00197	27.7	0.908	-177.4
2500	0.233	-177.6	9.748	-13.4	0.00181	34.5	0.924	-177.5
2550	0.178	179.0	8.983	-40.5	0.00204	31.5	0.943	-177.7
2600	0.123	-167.7	8.199	-65.8	0.00218	35.6	0.957	-178.0
2650	0.108	-148.8	7.452	-89.9	0.00208	33.2	0.970	-178.7
2700	0.121	-132.6	6.730	-113.1	0.00198	23.8	0.978	-179.6
2750	0.146	-119.9	6.008	-135.3	0.00191	31.0	0.985	179.4
2800	0.184	-119.9	5.323	-156.1	0.00211	23.7	0.987	178.3
2850	0.214	-121.0	4.700	-175.6	0.00159	15.5	0.987	177.3
2900	0.261	-127.6	4.109	166.0	0.00205	14.6	0.985	176.3
2950	0.316	-134.0	3.591	149.0	0.00171	19.2	0.984	175.4
3000	0.372	-141.4	3.130	133.3	0.00103	16.7	0.984	174.5
3050	0.430	-150.2	2.733	118.1	0.00095	26.4	0.984	173.8
3100	0.485	-158.9	2.388	103.6	0.00103	36.9	0.984	173.2
3150	0.534	-166.3	2.091	90.1	0.00108	24.1	0.985	172.7
3200	0.585	-172.7	1.846	77.3	0.00127	47.6	0.984	172.4
3250	0.625	-178.0	1.635	65.2	0.00119	57.1	0.986	172.1
3300	0.657	177.3	1.472	52.9	0.00132	53.2	0.985	171.9
3350	0.686	173.2	1.342	40.8	0.00200	53.8	0.985	171.7

(continued)

Table 7. Common Source S-Parameters ($V_{DD} = 28\text{ V}$, $I_{DQ1} = 160\text{ mA}$, $I_{DQ2} = 550\text{ mA}$, $T_C = 25^\circ\text{C}$, 50 Ohm System) (continued)

f MHz	S ₁₁		S ₂₁		S ₁₂		S ₂₂	
	S ₁₁	∠φ	S ₂₁	∠φ	S ₁₂	∠φ	S ₂₂	∠φ
3400	0.702	169.7	1.243	28.4	0.00230	54.4	0.982	171.3
3450	0.718	166.7	1.193	10.8	0.00211	62.5	0.947	170.1
3500	0.721	164.7	0.937	3.1	0.00233	24.3	0.976	173.0
3550	0.746	162.0	0.914	-7.9	0.00213	51.7	0.981	171.9
3600	0.758	158.9	0.857	-21.4	0.00236	55.6	0.978	171.1

ALTERNATIVE PEAK TUNE LOAD PULL CHARACTERISTICS

[查询"MW7IC2750N"供应商](#)

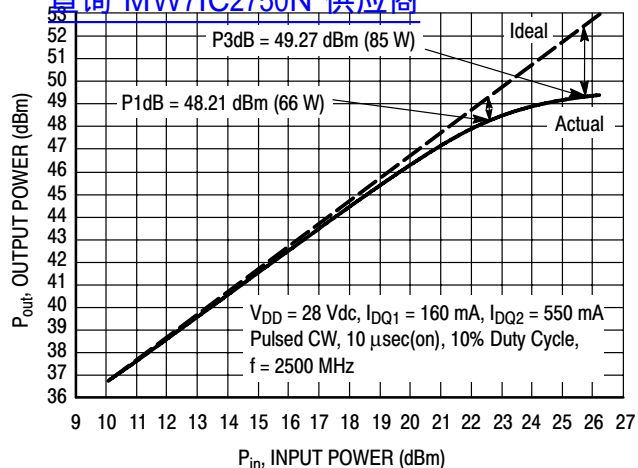

NOTE: Load Pull Test Fixture Tuned for Peak P1dB Output Power @ 28 V

Test Impedances per Compression Level

	Z_{source} Ω	Z_{load} Ω
P1dB	$28.46 + j5.15$	$1.67 - j1.53$

Figure 17. Pulsed CW Output Power versus Input Power @ 28 V @ 2500 MHz

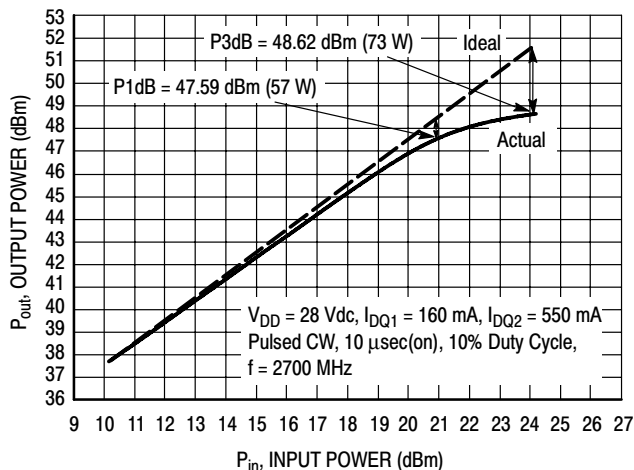

NOTE: Load Pull Test Fixture Tuned for Peak P1dB Output Power @ 28 V

Test Impedances per Compression Level

	Z_{source} Ω	Z_{load} Ω
P1dB	$36.24 + j1.75$	$1.19 - j1.29$

Figure 18. Pulsed CW Output Power versus Input Power @ 28 V @ 2700 MHz

PACKAGE DIMENSIONS

[查询"MW7IC2750N"供应商](#)

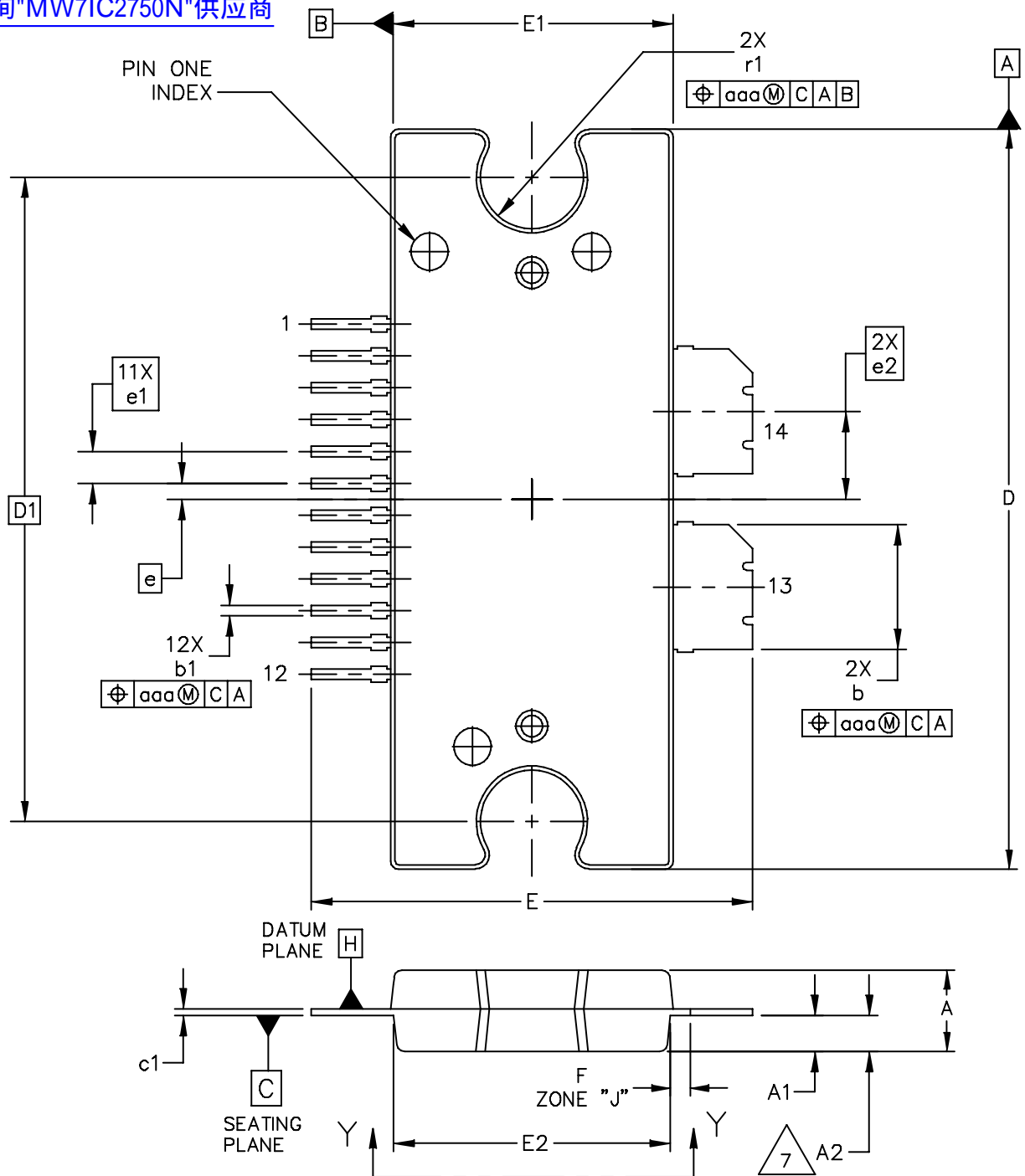

<p>© FREESCALE SEMICONDUCTOR, INC. ALL RIGHTS RESERVED.</p>	<p>MECHANICAL OUTLINE</p>	<p>PRINT VERSION NOT TO SCALE</p>	
<p>TITLE: TO-272 WIDE BODY 14 LEAD</p>	<p>DOCUMENT NO: 98ASA10649D</p>	<p>REV: A</p>	
	<p>CASE NUMBER: 1617-02</p>	<p>27 JUN 2007</p>	
	<p>STANDARD: NON-JEDEC</p>		

MW7IC2750NR1 MW7IC2750GNR1 MW7IC2750NBR1

[查询"MW7IC2750N"供应商](#)

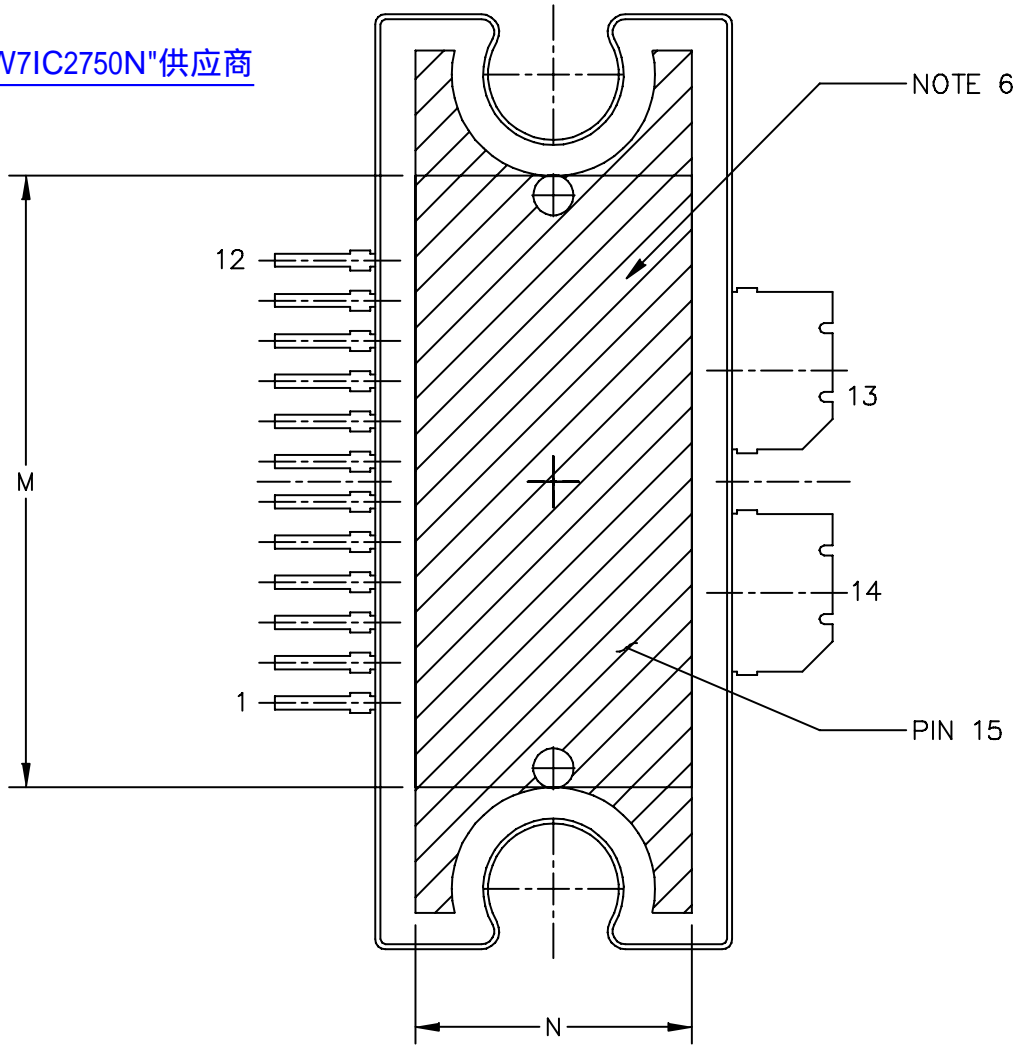

VIEW Y-Y

© FREESCALE SEMICONDUCTOR, INC. ALL RIGHTS RESERVED.		MECHANICAL OUTLINE	PRINT VERSION NOT TO SCALE
TITLE: TO-272 WIDE BODY 14 LEAD	DOCUMENT NO: 98ASA10649D		REV: A
	CASE NUMBER: 1617-02		27 JUN 2007
	STANDARD: NON-JEDEC		

NOTES:

查询"MW7IC2750N"供应商
 CONTROLLED DIMENSION: INCH

2. INTERPRET DIMENSIONS AND TOLERANCES PER ASME Y14.5M-1994.
3. DATUM PLANE -H- IS LOCATED AT THE TOP OF LEAD AND IS COINCIDENT WITH THE LEAD WHERE THE LEAD EXITS THE PLASTIC BODY AT THE TOP OF THE PARTING LINE.
4. DIMENSIONS "D" AND "E1" DO NOT INCLUDE MOLD PROTRUSION. ALLOWABLE PROTRUSION IS .006 (0.15) PER SIDE. DIMENSIONS "D" AND "E1" DO INCLUDE MOLD MISMATCH AND ARE DETERMINED AT DATUM PLANE -H-.
5. DIMENSIONS "b" AND "b1" DO NOT INCLUDE DAMBAR PROTRUSION. ALLOWABLE DAMBAR PROTRUSION SHALL BE .005 (0.13) TOTAL IN EXCESS OF THE "b" AND "b1" DIMENSIONS AT MAXIMUM MATERIAL CONDITION.
6. HATCHING REPRESENTS THE EXPOSED AREA OF THE HEAT SLUG.
7. DIM A2 APPLIES WITHIN ZONE "J" ONLY.

DIM	INCH		MILLIMETER		DIM	INCH		MILLIMETER	
	MIN	MAX	MIN	MAX		MIN	MAX	MIN	MAX
A	.100	.104	2.54	2.64	b	.154	.160	3.91	4.06
A1	.039	.043	0.99	1.09	b1	.010	.016	0.25	0.41
A2	.040	.042	1.02	1.07	c1	.007	.011	0.18	0.28
D	.928	.932	23.57	23.67	e	.020 BSC		0.51 BSC	
D1	.810 BSC		20.57 BSC		e1	.040 BSC		1.02 BSC	
E	.551	.559	14.00	14.20	e2	.1105 BSC		2.807 BSC	
E1	.353	.357	8.97	9.07	r1	.063	.068	1.6	1.73
E2	.346	.350	8.79	8.89	aaa	.004		0.10	
F	.025 BSC		0.64 BSC						
M	.600	----	15.24	----					
N	.270	----	6.86	----					
© FREESCALE SEMICONDUCTOR, INC. ALL RIGHTS RESERVED.			MECHANICAL OUTLINE			PRINT VERSION NOT TO SCALE			
TITLE: TO-272 WIDE BODY 14 LEAD					DOCUMENT NO: 98ASA10649D			REV: A	
					CASE NUMBER: 1617-02			27 JUN 2007	
					STANDARD: NON-JEDEC				

MW7IC2750NR1 MW7IC2750GNR1 MW7IC2750NBR1

[查询"MW7IC2750N"供应商](#)

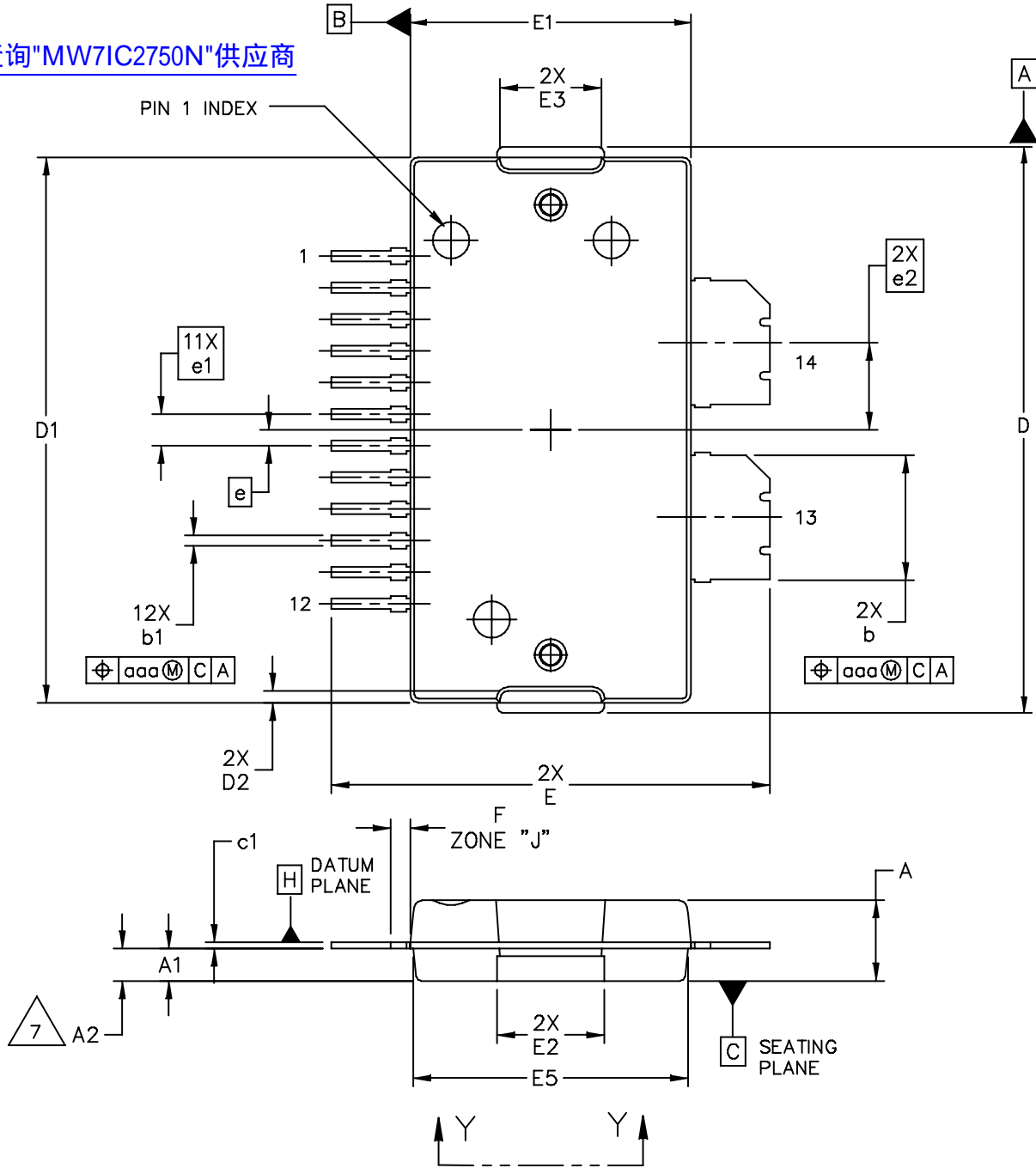

© FREESCALE SEMICONDUCTOR, INC. ALL RIGHTS RESERVED.	MECHANICAL OUTLINE	PRINT VERSION NOT TO SCALE	
TITLE: TO-270 WIDE BODY 14 LEAD		DOCUMENT NO: 98ASA10650D	REV: A
		CASE NUMBER: 1618-02	19 JUN 2007
		STANDARD: NON-JEDEC	

[查询"MW7IC2750N"供应商](#)

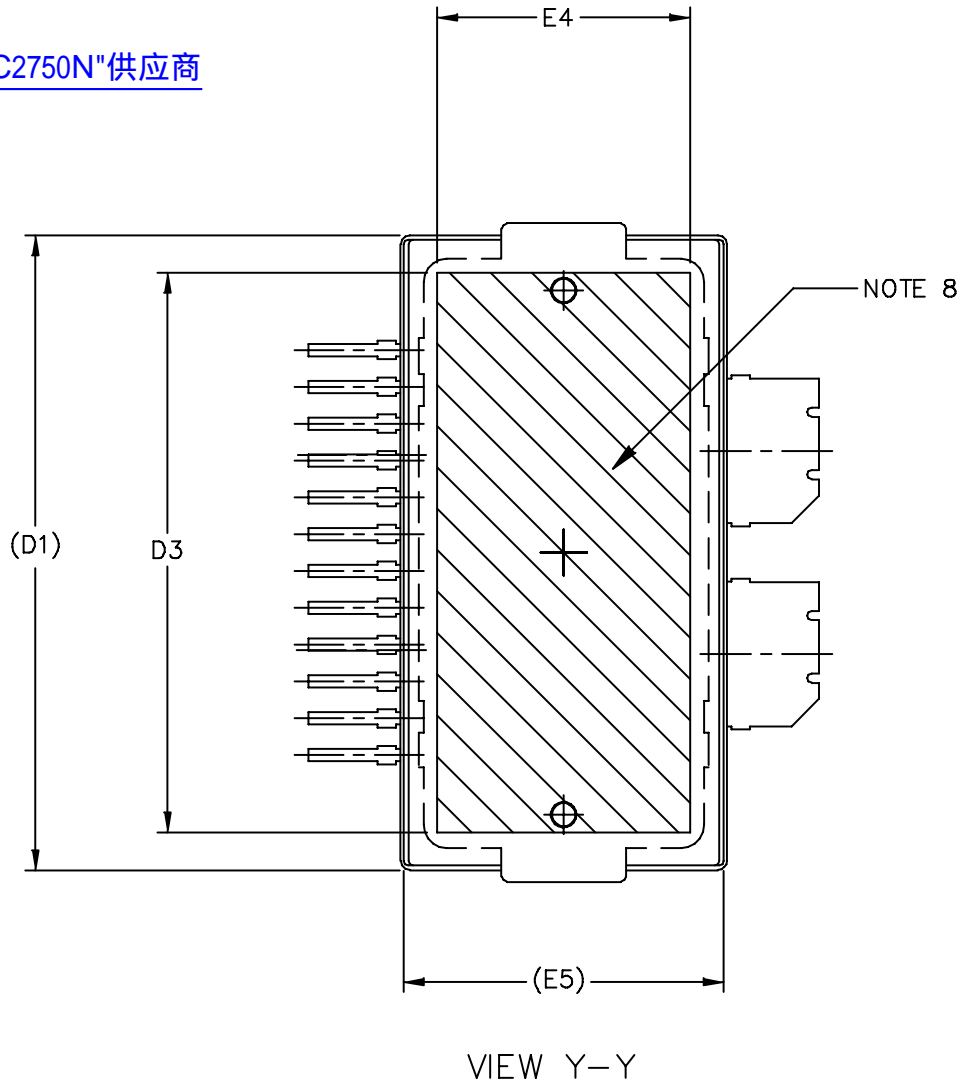

© FREESCALE SEMICONDUCTOR, INC. ALL RIGHTS RESERVED.	MECHANICAL OUTLINE	PRINT VERSION NOT TO SCALE	
TITLE: TO-270 WIDE BODY 14 LEAD	DOCUMENT NO: 98ASA10650D	REV: A	
	CASE NUMBER: 1618-02	19 JUN 2007	
	STANDARD: NON-JEDEC		

MW7IC2750NR1 MW7IC2750GNR1 MW7IC2750NBR1

NOTES:

1. CONTROLLING DIMENSION: INCH
[查询"MW7IC2750N"供应商](#)
2. INTERPRET DIMENSIONS AND TOLERANCES PER ASME Y14.5M-1994.
3. DATUM PLANE -H- IS LOCATED AT THE TOP OF LEAD AND IS COINCIDENT WITH THE LEAD WHERE THE LEAD EXITS THE PLASTIC BODY AT THE TOP OF THE PARTING LINE.
4. DIMENSIONS "D" AND "E1" DO NOT INCLUDE MOLD PROTRUSION. ALLOWABLE PROTRUSION IS .006 PER SIDE. DIMENSIONS "D" AND "E1" DO INCLUDE MOLD MISMATCH AND ARE DETERMINED AT DATUM PLANE -H-.
5. DIMENSIONS "b" AND "b1" DOES NOT INCLUDE DAMBAR PROTRUSION. ALLOWABLE DAMBAR PROTRUSION SHALL BE .005 TOTAL IN EXCESS OF THE "b" AND "b1" DIMENSION AT MAXIMUM MATERIAL CONDITION.
6. DATUMS -A- AND -B- TO BE DETERMINED AT DATUM PLANE -H-.
7. DIMENSION A2 APPLIES WITHIN ZONE "J" ONLY.
8. HATCHING REPRESENTS THE EXPOSED AREA OF THE HEAT SLUG.

DIM	INCH		MILLIMETER		DIM	INCH		MILLIMETER	
	MIN	MAX	MIN	MAX		MIN	MAX	MIN	MAX
A	.100	.104	2.54	2.64	F	.025 BSC		0.64 BSC	
A1	.039	.043	0.99	1.09	b	.154	.160	3.91	4.06
A2	.040	.042	1.02	1.07	b1	.010	.016	0.25	0.41
D	.712	.720	18.08	18.29	c1	.007	.011	.18	.28
D1	.688	.692	17.48	17.58	e	.020 BSC		0.51 BSC	
D2	.011	.019	0.28	0.48	e1	.040 BSC		1.02 BSC	
D3	.600	---	15.24	---	e2	.1105 BSC		2.807 BSC	
E	.551	.559	14	14.2					
E1	.353	.357	8.97	9.07	aaa	.004		.10	
E2	.132	.140	3.35	3.56					
E3	.124	.132	3.15	3.35					
E4	.270	---	6.86	---					
E5	.346	.350	8.79	8.89					
© FREESCALE SEMICONDUCTOR, INC. ALL RIGHTS RESERVED.			MECHANICAL OUTLINE			PRINT VERSION NOT TO SCALE			
TITLE: TO-270 WIDE BODY 14 LEAD					DOCUMENT NO: 98ASA10650D			REV: A	
					CASE NUMBER: 1618-02			19 JUN 2007	
					STANDARD: NON-JEDEC				

查询"MW7IC2750N"供应商

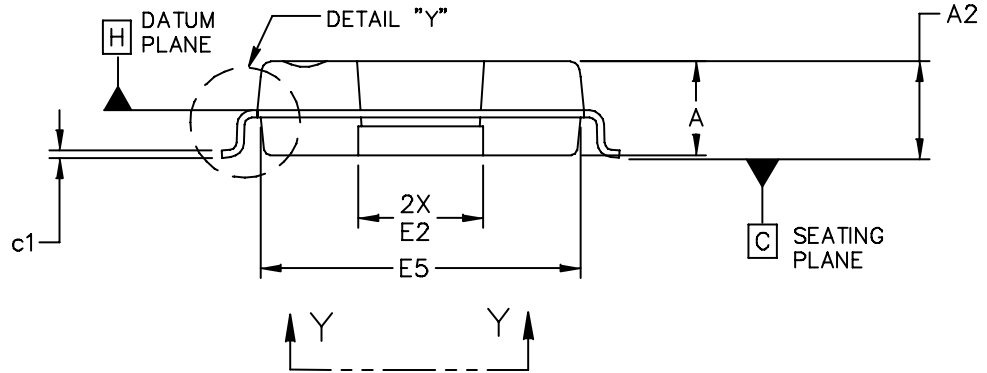
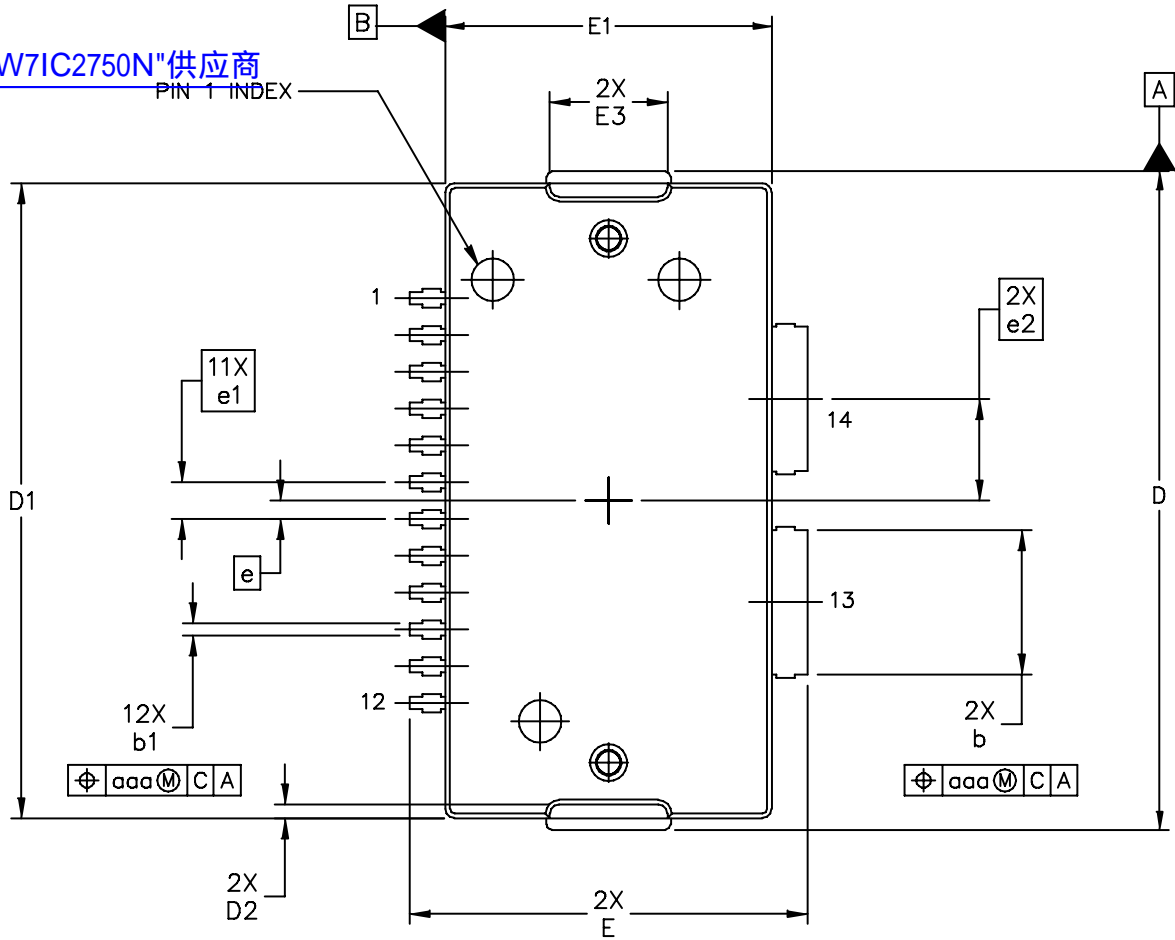

© FREESCALE SEMICONDUCTOR, INC. ALL RIGHTS RESERVED.	MECHANICAL OUTLINE	PRINT VERSION NOT TO SCALE	
TITLE: TO-270 WIDE BODY 14 LEAD GULL WING	DOCUMENT NO: 98ASA10653D	REV: A	
	CASE NUMBER: 1621-02	19 JUN 2007	
	STANDARD: NON-JEDEC		

MW7IC2750NR1 MW7IC2750GNR1 MW7IC2750NBR1

[查询"MW7IC2750N"供应商](#)

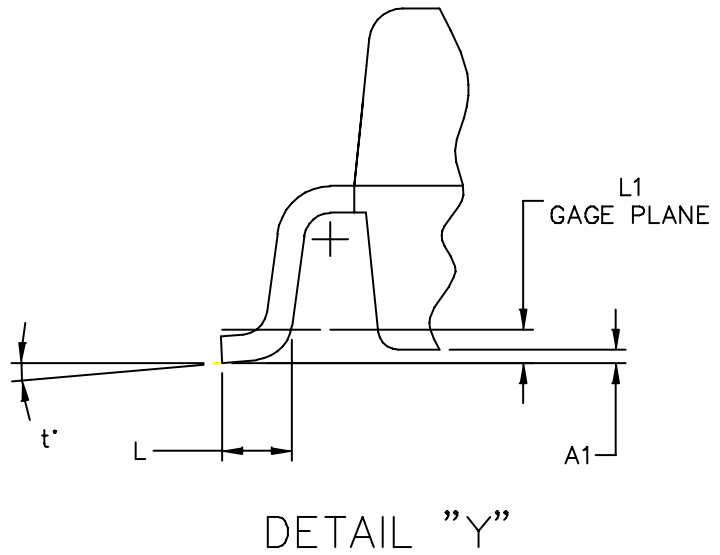
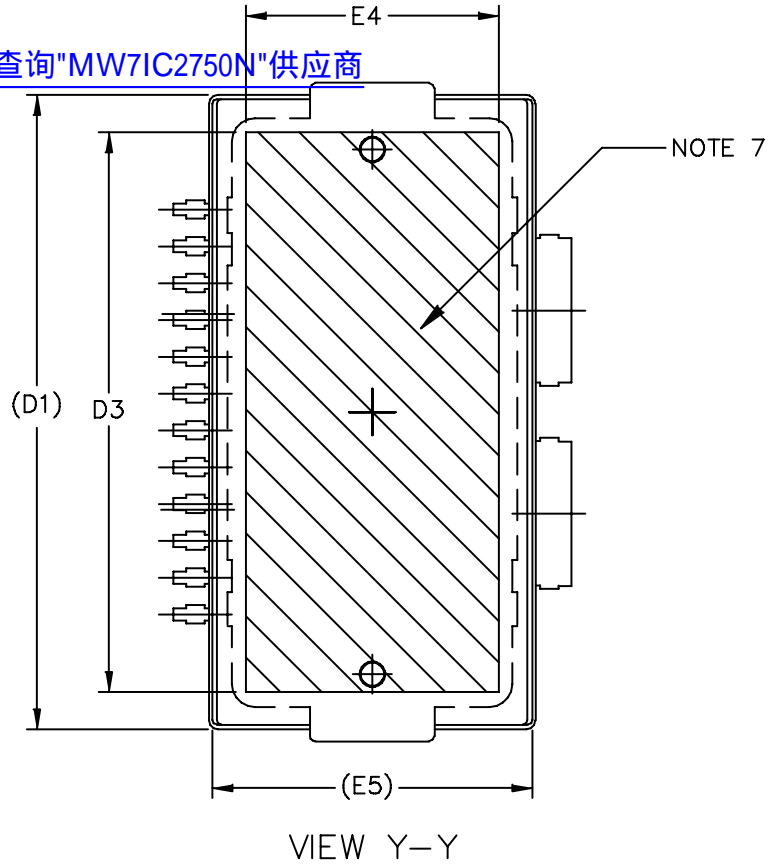

© FREESCALE SEMICONDUCTOR, INC. ALL RIGHTS RESERVED.	MECHANICAL OUTLINE	PRINT VERSION NOT TO SCALE	
TITLE: TO-270 WIDE BODY 14 LEAD GULL WING	DOCUMENT NO: 98ASA10653D	REV: A	
	CASE NUMBER: 1621-02	19 JUN 2007	
	STANDARD: NON-JEDEC		

NOTES:

1. CONTROLLING DIMENSION: INCH
[查询"MW7IC2750N"供应商](#)

2. INTERPRET DIMENSIONS AND TOLERANCES PER ASME Y14.5M-1994.
3. DATUM PLANE -H- IS LOCATED AT THE TOP OF LEAD AND IS COINCIDENT WITH THE LEAD WHERE THE LEAD EXITS THE PLASTIC BODY AT THE TOP OF THE PARTING LINE.
4. DIMENSIONS "D" AND "E1" DO NOT INCLUDE MOLD PROTRUSION. ALLOWABLE PROTRUSION IS .006 PER SIDE. DIMENSIONS "D" AND "E1" DO INCLUDE MOLD MISMATCH AND ARE DETERMINED AT DATUM PLANE -H-.
5. DIMENSIONS "b" AND "b1" DOES NOT INCLUDE DAMBAR PROTRUSION. ALLOWABLE DAMBAR PROTRUSION SHALL BE .005 TOTAL IN EXCESS OF THE "b" AND "b1" DIMENSION AT MAXIMUM MATERIAL CONDITION.
6. DATUMS -A- AND -B- TO BE DETERMINED AT DATUM PLANE -H-.
7. HATCHING REPRESENTS THE EXPOSED AREA OF THE HEAT SLUG.

DIM	INCH		MILLIMETER		DIM	INCH		MILLIMETER	
	MIN	MAX	MIN	MAX		MIN	MAX	MIN	MAX
A	.100	.104	2.54	2.64	L	.018	.024	0.46	0.61
A1	.001	.004	0.02	0.10	L1	.010 BSC		0.25 BSC	
A2	.099	.110	2.51	2.79	b	.154	.160	3.91	4.06
D	.712	.720	18.08	18.29	b1	.010	.016	0.25	0.41
D1	.688	.692	17.48	17.58	c1	.007	.011	.18	.28
D2	.011	.019	0.28	0.48	e	.020 BSC		0.51 BSC	
D3	.600	---	15.24	---	e1	.040 BSC		1.02 BSC	
E	.429	.437	10.9	11.1	e2	.1105 BSC		2.807 BSC	
E1	.353	.357	8.97	9.07	t	2'	8'	2'	8'
E2	.132	.140	3.35	3.56					
E3	.124	.132	3.15	3.35	aaa	.004		.10	
E4	.270	---	6.86	---					
E5	.346	.350	8.79	8.89					
© FREESCALE SEMICONDUCTOR, INC. ALL RIGHTS RESERVED.			MECHANICAL OUTLINE			PRINT VERSION NOT TO SCALE			
TITLE: TO-270 WIDE BODY 14 LEAD GULL WING					DOCUMENT NO: 98ASA10653D			REV: A	
					CASE NUMBER: 1621-02			19 JUN 2007	
					STANDARD: NON-JEDEC				

PRODUCT DOCUMENTATION, TOOLS AND SOFTWARE

[查询"MW71C2750N"供应商](#)

Refer to the following documents to aid your design process.

Application Notes

- AN1907: Solder Reflow Attach Method for High Power RF Devices in Plastic Packages
- AN1955: Thermal Measurement Methodology of RF Power Amplifiers
- AN1977: Quiescent Current Thermal Tracking Circuit in the RF Integrated Circuit Family
- AN1987: Quiescent Current Control for the RF Integrated Circuit Device Family
- AN3263: Bolt Down Mounting Method for High Power RF Transistors and RFICs in Over-Molded Plastic Packages
- AN3789: Clamping of High Power RF Transistors and RFICs in Over-Molded Plastic Packages

Engineering Bulletins

- EB212: Using Data Sheet Impedances for RF LDMOS Devices

Software

- Electromigration MTTF Calculator
- RF High Power Model
- .s2p File

Development Tools

- Printed Circuit Boards

For Software and Tools, do a Part Number search at <http://www.freescale.com>, and select the "Part Number" link. Go to the Software & Tools tab on the part's Product Summary page to download the respective tool.

REVISION HISTORY

The following table summarizes revisions to this document.

Revision	Date	Description
0	May 2008	<ul style="list-style-type: none">• Initial Release of Data Sheet
1	Oct. 2008	<ul style="list-style-type: none">• Corrected footnote reference in Typical Performances OFDM Signal - 10 MHz Bandwidth table, p. 3• Updated Fig. 13, MTTF versus Junction Temperature, to correct a calculation error, p. 9
2	Feb. 2010	<ul style="list-style-type: none">• Modified VSWR rating to show the 3 dB overdrive capability, p. 1• Corrected maximum input power level to the tested value, from 13 dBm to 25 dBm in Maximum Ratings table, p. 2• Fig. 3, Test Circuit Schematic, corrected Rogers RO4350B dielectric constant from 3.66 ϵ_r to 3.5 ϵ_r, p. 5• Added AN3789, Clamping of High Power RF Transistors and RFICs in Over-Molded Plastic Packages to Product Documentation, Application Notes, p. 24

How to Reach Us:

Home Page:

www.freescale.com

Web Support:

<http://www.freescale.com/support>

USA/Europe or Locations Not Listed:

Freescale Semiconductor, Inc.
Technical Information Center, EL516
2100 East Elliot Road
Tempe, Arizona 85284
1-800-521-6274 or +1-480-768-2130
www.freescale.com/support

Europe, Middle East, and Africa:

Freescale Halbleiter Deutschland GmbH
Technical Information Center
Schatzbogen 7
81829 Muenchen, Germany
+44 1296 380 456 (English)
+46 8 52200080 (English)
+49 89 92103 559 (German)
+33 1 69 35 48 48 (French)
www.freescale.com/support

Japan:

Freescale Semiconductor Japan Ltd.
Headquarters
ARCO Tower 15F
1-8-1, Shimo-Meguro, Meguro-ku,
Tokyo 153-0064
Japan
0120 191014 or +81 3 5437 9125
support.japan@freescale.com

Asia/Pacific:

Freescale Semiconductor China Ltd.
Exchange Building 23F
No. 118 Jianguo Road
Chaoyang District
Beijing 100022
China
+86 10 5879 8000
support.asia@freescale.com

For Literature Requests Only:

Freescale Semiconductor Literature Distribution Center
1-800-441-2447 or +1-303-675-2140
Fax: +1-303-675-2150
LDCForFreescaleSemiconductor@hibbertgroup.com

Information in this document is provided solely to enable system and software implementers to use Freescale Semiconductor products. There are no express or implied copyright licenses granted hereunder to design or fabricate any integrated circuits or integrated circuits based on the information in this document.

Freescale Semiconductor reserves the right to make changes without further notice to any products herein. Freescale Semiconductor makes no warranty, representation or guarantee regarding the suitability of its products for any particular purpose, nor does Freescale Semiconductor assume any liability arising out of the application or use of any product or circuit, and specifically disclaims any and all liability, including without limitation consequential or incidental damages. "Typical" parameters that may be provided in Freescale Semiconductor data sheets and/or specifications can and do vary in different applications and actual performance may vary over time. All operating parameters, including "Typicals", must be validated for each customer application by customer's technical experts. Freescale Semiconductor does not convey any license under its patent rights nor the rights of others. Freescale Semiconductor products are not designed, intended, or authorized for use as components in systems intended for surgical implant into the body, or other applications intended to support or sustain life, or for any other application in which the failure of the Freescale Semiconductor product could create a situation where personal injury or death may occur. Should Buyer purchase or use Freescale Semiconductor products for any such unintended or unauthorized application, Buyer shall indemnify and hold Freescale Semiconductor and its officers, employees, subsidiaries, affiliates, and distributors harmless against all claims, costs, damages, and expenses, and reasonable attorney fees arising out of, directly or indirectly, any claim of personal injury or death associated with such unintended or unauthorized use, even if such claim alleges that Freescale Semiconductor was negligent regarding the design or manufacture of the part.

Freescale™ and the Freescale logo are trademarks of Freescale Semiconductor, Inc. All other product or service names are the property of their respective owners.

© Freescale Semiconductor, Inc. 2008, 2010. All rights reserved.